

PFA FF

422-720/04
1422-720/04

Teileliste

List of parts

Liste de pièces

Lista de piezas

Die Inhaltsübersicht auf Seite 3 gibt einen Überblick über die Aufgliederung der Liste.
Die Teile sind so abgebildet, wie sie in der Maschine funktionsmäßig zusammengehören.
Die gestrichelten Abbildungen zeigen, wo die daneben abgebildeten Teile hingehören.
Die Einrahmungen auf den Bildseiten zeigen, aus welchen Einzelteilen sich die Gruppenteile zusammensetzen.
Nähwerkzeuge und Apparate sind der Unterklassen-Ausstattung zu entnehmen (siehe Anhang).
Die auf den Bildseiten verwendeten Schlüsselzeichen (□; 3; 6 usw.) sind in Register „0“ zusammengefaßt und erläutert.
Konstruktionsänderungen vorbehalten.

For the various sections of this catalogue, please refer to the "Contents" on page 3.
The parts are illustrated as they belong together in the machine.
The dashed illustrations show where the adjacent parts belong.
The framed-in sections on the illustration pages show the individual parts comprising a group.
For gauge parts and attachments please refer to the subclass listing (see appendix).
The keys used on the illustration pages (□; 3; 6 etc.) are listed and explained in section "0".
Subject to alterations in design.

La table des matières, page 3, donne un aperçu de la subdivision de la liste.
Les pièces figurent sur l'illustration comme elles vont ensemble.
Les figures en tirets montrent le lieu de montage des pièces figurant à côté.
Les parties encadrées sur les pages à illustrations représentent les pièces individuelles formant groupe.
Pour les organes de couture et les appareils, veuillez vous référer à la fiche équipement de sous-classes (voir en annexe).
Les symboles (□; 3; 6 etc.) utilisés sur les pages illustrées sont regroupés et expliqués au registre „0”.
Sous réserve de modifications.



En la página 3, bajo el título "contenido", puede verse un resumen de la división de la "lista de piezas".
Las piezas están ilustradas conforme se hallan montadas en la máquina.
Las figuras a base de líneas entrecortadas muestran dónde y cómo van montadas las piezas ilustradas al lado.
Los recuadros en las páginas ilustradas indican las piezas individuales de que se componen los grupos.
Para los órganos de costura y aparatos, véase la „Composición de las subclases" (en el anexo).
Los símbolos clave (□; 3; 6, etc.) utilizados en las páginas ilustradas se hallan recopilados y explicados en el registro „0”.
Salvo modificaciones técnicas.

Contents
Table des matières **Pfaff 422-720/04**
Contenido **Pfaff 1422-720/04**

Register Section Registre Registro			Seite Page Págir
	Schmiermittel-Tabelle Table of lubricants Tableau des lubrifiants Tabla de lubricantes		5
0	Erläuterungen Explanations Légende Explicaciones		6
1	Kopfteile Needle head parts Pièces de tête Piezas de la cabeza		9
2	Armteile Arm parts Pièces de bras Piezas del brazo		12
3	Grundplattenteile Bedplate parts Pièces du plateau fondamental Piezas de la placa-base		18
4	Gehäuseteile Housing sections Parties du corps Piezas del cárter		30
5	Walzentransport-Einrichtung Puller feed Puller Puller	-748/26	zur for Pfaff 422-720/04 pour Pfaff 1422-720/04 para
6	SENSEWMAT	-780/04	zur for Pfaff 422-720/04 pour Pfaff 1422-720/04 para
7	Fadenabschneid-Einrichtung Thread trimmer Coupe-fil Cortahilos	-900/61	zur for Pfaff 422-720/04 pour Pfaff 1422-720/04 para
8	Eckennahtsteuerung Corner seam control Contrôle de coutures angulaires Control para costuras angulares	-970/02	zur for Pfaff 422-720/04 pour Pfaff 1422-720/04 para
9	Unterklasse Subclass Sous-classe Subclase	-910/24-911/35	zur for Pfaff 422-720/04-748/26 pour Pfaff 1422-720/04-748/26 para
10	Unterklasse Subclass Sous-classe Subclase	-909/02-910/15-911/35	zur for Pfaff 422-720/04 pour Pfaff 1422-720/04 para
11	Unterklasse Subclass Sous-classe Subclase	-910/15-911/35	zur for Pfaff 1422-720/04 pour para
12	Fadenspannungs-Steuerung Thread tension control Commande de la tension du fil Control de la tensión del hilo superior	-906/03	zur for Pfaff 1422-720/04 pour para
13	Fadenspannungs-Steuerung Thread tension control Commande de la tension du fil Control de la tensión del hilo superior	-906/09	zur for Pfaff 422-720/04 pour Pfaff 1422-720/04 para

Register Section Registre Registro				Seite Page Página
14	Schalteinrichtung Switching system Dispositif de commande Mecanismo de mando	-918/26	zur for pour para Pfaff 1422-720/04	60
15	Spulensfadenvorratwächter Bobbin thread supply monitor Contrôleur de canette Detector del hilo de la canilla	-926/04	zur for pour para Pfaff 1422-720/04	61
16	Bedienfeld Control panel Panneau de commande Panel de control			64
17	Bediengerät Control panel Console de commande Panel de mando			64
18	Zubehörteile Accessory parts Accessoires Accesorios			65
19	Wartungseinheit Air filter/lubricator Conditionneur d'air comprimé Grupo acondicionador del aire comprimido			68
20	Positionsgeber Synchronizer Synchronisateur Sincronizador			70
21	Einstellehren Adjusting gauges Calibres Calibres de ajuste			71
22	Motoranschlußsatz Motor connection kit Jeu de pièces à raccorder le moteur Juego de piezas de conexión del motor		(Ausrüstung mit Motorschutzschalter) (equipment with motor overload trip) (avec contacteur-disjoncteur) (con interruptor de seguridad)	71
23	Glasfaserleuchte Glass fibre lamp Lampe de fibre optique Lámpara de fibra de vidrio			74
24	Keilriemenscheiben-Tabelle Table of V-belt pulleys Tableau des poulies à gorge en V Tabla de poleas para correas en "V"			75
25	Nummernverzeichnis Numerical index Tableau des numéros Índice numérico			76
Anhang Appendix Annexe Anexo	Unterklassen-Ausstattung Subclass parts Composition des sous-classes Composición de las subclases			

Lubricants
Lubrifiants Pfaff 422-720/04
Lubricantes Pfaff 1422-720/04

Öl Oil Huile Aceite	Mittelpunkts- Viskosität bei: Mean viscosity at: Viscosité moyenne à: Viscosidad media a:		Dichte bei: Density at: Densité à: Densidad a:		Bestellnummer für Behälter mit: Part number for can with: Numéro de commande pour récipients avec: Número de pedido para recipientes con:			
	°C	mm ² /s	°C	g/cm ³ (g/ml)	Liter Litre Litros			
280-1-120 144	50	15,0	15	0,865	80 (ml)	91-027 630-91		
					0,25		91-129 916-91	
					1		91-129 917-91	
					5			91-129 919-
					10			91-129 920-
					80 (ml)			
					0,25			
					1			
					5			
					10			
					80 (ml)			
					0,25			
					1			
					5			
					10			

Fett Grease Graisse Grasa	Penetration Penetration Pénétration Penetración	Tropfpunkt Drip-point Point de suintement Punto de goteo	Bestellnummer für Behälter mit: Part number for can with: Numéro de commande pour récipients avec: Número de pedido para recipientes con:			
			mm/10	°C	kg	
280-1-120 205			0,5			
			1			280-1-120 2
280-1-120 243	375 - 405	150	0,5	280-1-120 243		
			1			
280-1-120 247	220 - 250	185	0,5			
			1		280-1-120 247	

O

- A** Ausführung A
Model A
Version A
Tipo A
- B** Ausführung B
Model B
Version B
Tipo B
- C** Ausführung C
Model C
Version C
Tipo C
- Unterklassenabhängig, Teilenummer siehe Unterklassen-Ausstattung.
Subclass-dependent, for part number see subclass parts listing.
Fonction de la sous-classe; pour le numéro de la pièce, voir "Equipement de sous-classes".
Dependientes de la subclase, para el N° de pieza véase "Dotación de subclases".
- 2** Markierung (Punkte, Striche oder Zahl) bei Bestellung angeben.
Marking (dots, strokes or numbers) to be stated on order.
Préciser les repères (points, traits ou chiffres) à la commande.
Señales (puntos, rayas o cifras), indíquese en los pedidos.
- 3** Geklebt
Part cemented
Pièce collée
Pieza pegada
- 3/1** Gesichert mit Loctite.
Secured with Loctite.
Bloqué par Loctite.
Asegurado con Loctite.
- 6** Nadeldicke und Spitzenform bei Bestellung angeben.
Needle size and style of point to be stated on order.
Préciser la grosseur de l'aiguille et la forme de la pointe à la commande.
Grosor de aguja y forma de la punta, indíquese en los pedidos.
- 10/2** Nadelabstand bei Bestellung angeben.
Needle gauge to be stated on order.
Écartement des aiguilles; à préciser à la commande.
Indíquese en los pedidos la distancia entre agujas.
- 10/5** Für Nadelabstand von 2,4 mm.
For needle gauge from 2.4 mm.
Pour écartement des aiguilles entre 2,4 mm.
Para distancia entre agujas de 2,4 mm.
- 27/2** Eingeklammerte Zahl = Dicke in mm.
Number in brackets = thickness in mm.
Chiffre entre parenthèses = épaisseur en mm.
Cifra entre paréntesis = espesor en mm.
- 27/5** Eingeklammerte Zahl = Länge in mm.
Number in brackets = length in mm.
Chiffre entre parenthèses = longueur en mm.
Cifra entre paréntesis = largura en mm.
- 27/12** Eingeklammerte Zahl = Durchmesser x Breite in mm.
Number in brackets = diameter x width in mm.
Chiffre entre parenthèses = diamètre x largeur en mm.
Cifra entre paréntesis = diámetro x anchura en mm.
- 28** Sonderausführung
Special version
Version spéciale
Tipo especial
- 32** Beim Einbau dieses Teiles wird für die Paßgenauigkeit zum Anschlußteil keine Garantie übernommen; zweckmäßig vollständigem Aggregat bestellen.
No guarantee is assumed that this part will fit the mating part; it is best to order a complete assembly.
Aucune garantie ne pourra être assurée quant à la précision d'ajustage de cette pièce avec la pièce correspondante; il est indiqué de commander un mécanisme complet.
Al montar esta pieza no se asume garantía alguna en cuanto a la tolerancia y precisión de ajuste respecto a la pieza correspondiente; por esta razón se recomienda pedir el grupo completo.

- 32/1** Beim Einbau dieses Teiles ist Nacharbeit erforderlich.
When fitting this part re-work is required.
Retouches nécessaires au montage.
Al montar esta pieza hay que retocarla antes.
- 35/1** Bei Montage vernieten.
To be riveted after assembly.
River après montage.
Remáchese después del montaje.
- 38/7** Kunststoffbeschichtet
Plastic-coated
A enduction plastique
Revestido de plástico
- 38/8** Gezahnt
Toothed
Dentée
Dentado
- 38/9** Gerändelt
Knurled
Mollelé
Moleteado
- 40/1** Füllen mit 280-1-120 144, Bestellnummer siehe Seite 5.
Top up with 280-1-120 144, for part number see page 5.
Remplir de 280-1-120 144; n° de commande, voir page 5.
Rellene con 280-1-120 144; para el N° de pedido véase la página 5.
- 40/2** Tränken mit 280-1-120 144, Bestellnummer siehe Seite 5.
Soak with 280-1-120 144, for part number see page 5.
Imbiber d'huile 280-1-120 144; n° de commande, voir page 5.
Empape con aceite 280-1-120 144; para el N° de pedido véase la página 5.
- 40/3** Fetten mit 280-1-120 247, Bestellnummer siehe Seite 5.
Grease with 280-1-120 247, for part number see page 5.
Graisser avec de la graisse 280-1-120 247; n° de commande, voir page 5.
Engrase con grasa 280-1-120 247; para el N° de pedido véase la página 5.
- 40/4** Fetten mit 280-1-120 243, Bestellnummer siehe Seite 5.
Grease with 280-1-120 243, for part number see page 5.
Graisser avec de la graisse 280-1-120 243; n° de commande, voir page 5.
Engrase con grasa 280-1-120 243; para el N° de pedido véase la página 5.
- 40/5** Ölen mit 280-1-120 144, Bestellnummer siehe Seite 5.
Oil with 280-1-120 144, for part number see page 5.
Huiler par 280-1-120 144; n° de commande, voir page 5.
Lubrifique con 280-1-120 144; para el N° de pedido véase la página 5.
- 40/13** Fetten mit 280-1-120 205, Bestellnummer siehe Seite 5.
Grease with 280-1-120 205, for part number see page 5.
Graisser avec de la graisse 280-1-120 205; n° de commande, voir page 5.
Engrase con grasa 280-1-120 205; para el N° de pedido véase la página 5.
- 40/20** Füllen mit 50 ml 280-1-120 122.
Top up with 50 ml 280-1-120 122.
Remplir avec 50 ml 280-1-120 122.
Rellénesse con 50 ml 280-1-120 122.
- 80/3** Für Schlauch mit 3 mm Innendurchmesser.
For tube with 3 mm inside diameter.
Pour flexible d'un diamètre intérieur de 3 mm.
Para tubo flexible de 3 mm diámetro interior.
- 80/4** Für Schlauch mit 4 mm Innendurchmesser.
For tube with 4 mm inside diameter.
Pour flexible d'un diamètre intérieur de 4 mm.
Para tubo flexible de 4 mm diámetro interior.
- 80/6** Für Schlauch mit 6 mm Innendurchmesser.
For tube with 6 mm inside diameter.
Pour flexible d'un diamètre intérieur de 6 mm.
Para tubo flexible de 6 mm diámetro interior.
- 81/3** Verwendung je nach Bedarf.
To be used as required.
Utilisation en fonction du besoin.
Utilización, según sea necesario.
-

O

- 81/4** Verwendung nur bei Bedarf.
To be used only if required.
Utilisation uniquement suivant besoin.
Utilización, sólo cuando se necesite.
- 90/1** Für Wechselstrom.
For single-phase A.C.
Pour du courant alternatif.
Para corriente alterna monofásica.
- 90/2** Für Drehstrom.
For three-phase A.C.
Pour du courant triphasé.
Para corriente trifásica.
- 90/3** Zur Motorbefestigung.
For fitting the motor.
Pour la fixation du moteur.
Para fijación del motor.
- 90/10** Für Maschinen ohne -900/..
For machines without -900/..
Pour machines sans -900/..
Para máquinas sin -900/..
- 90/38** Mit -900/.. ohne Anbau-Unterklassen.
With -900/.. without mechanical subclasses.
Avec -900/.. sans sous-classes mécaniques.
Con -900/.. sin subclases mecánicas.
- 90/39** Mit -900/.. mit Anbau-Unterklassen.
With -900/.. with mechanical subclasses.
Avec -900/.. avec sous-classes mécaniques.
Con -900/.. con subclases mecánicas.
- 96** Länge angeben.
State length.
Préciser longueur.
Indíquese la largura.
- 96/2** Schlauch mit 2 mm Innendurchmesser, bei Bestellung Länge angeben.
Tube with 2 mm inside dia.; length to be stated on order.
Flexible d'un diamètre intérieur de 2 mm; préciser la longueur.
Tubo flexible de 2 mm de diámetro interior; indíquese la largura en los pedidos.
- 96/3** Schlauch mit 3 mm Innendurchmesser, bei Bestellung Länge angeben.
Tube with 3 mm inside dia.; length to be stated on order.
Flexible d'un diamètre intérieur de 3 mm; préciser la longueur.
Tubo flexible de 3 mm de diámetro interior; indíquese la largura en los pedidos.
- 96/4** Schlauch mit 4 mm Innendurchmesser, bei Bestellung Länge angeben.
Tube with 4 mm inside dia.; length to be stated on order.
Flexible d'un diamètre intérieur de 4 mm; préciser la longueur.
Tubo flexible de 4 mm de diámetro interior; indíquese la largura en los pedidos.
- 96/6** Schlauch mit 6 mm Innendurchmesser, bei Bestellung Länge angeben.
Tube with 6 mm inside dia.; length to be stated on order.
Flexible d'un diamètre intérieur de 6 mm; préciser la longueur.
Tubo flexible de 6 mm de diámetro interior; indíquese la largura en los pedidos.

Needle head parts
Pièces de tête Pfaff 422-720/04
Piezas de la cabeza Pfaff 1422-720/04

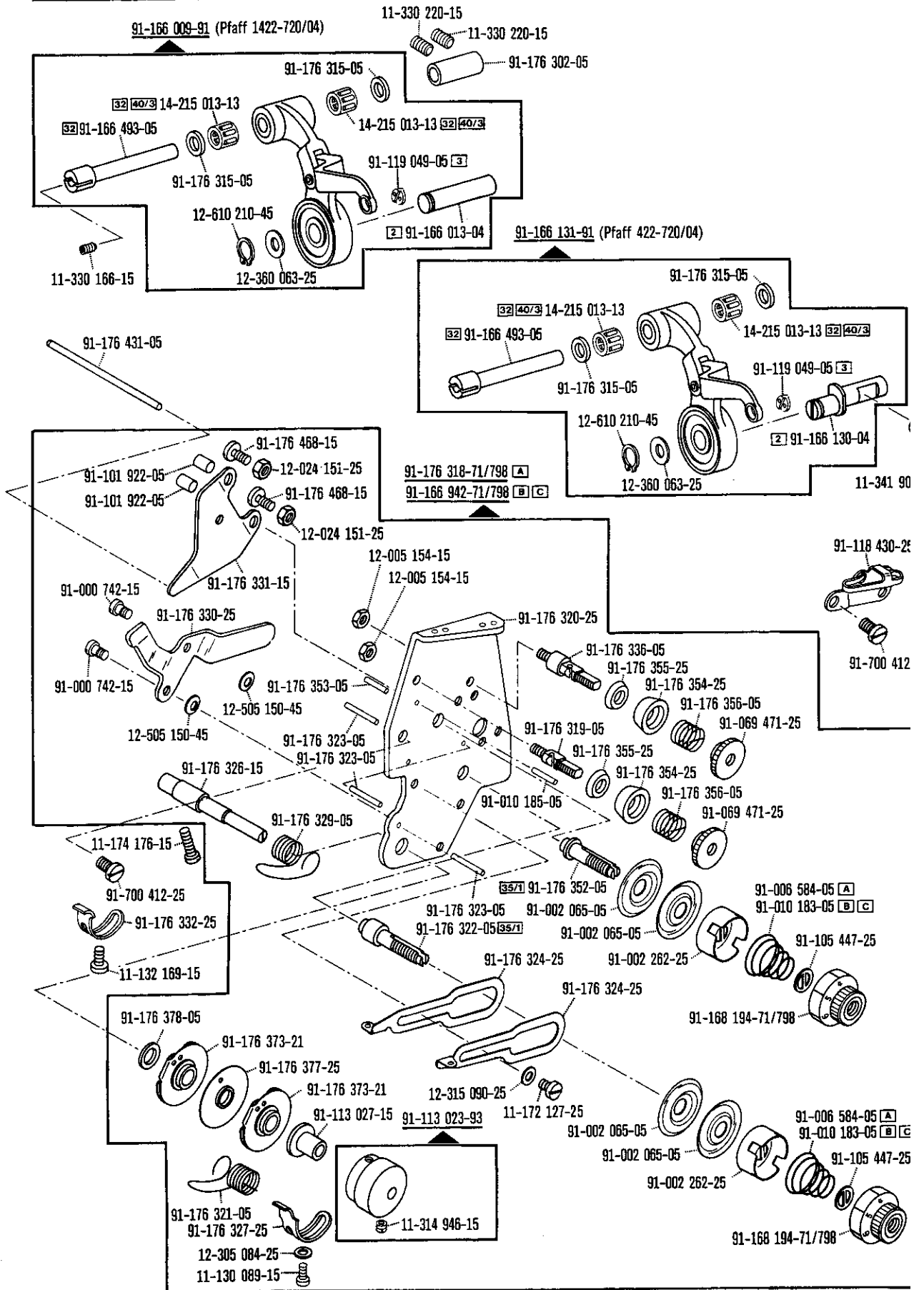

☐ siehe Erläuterungen Register 0
 ☐ see explanations in register 0

1

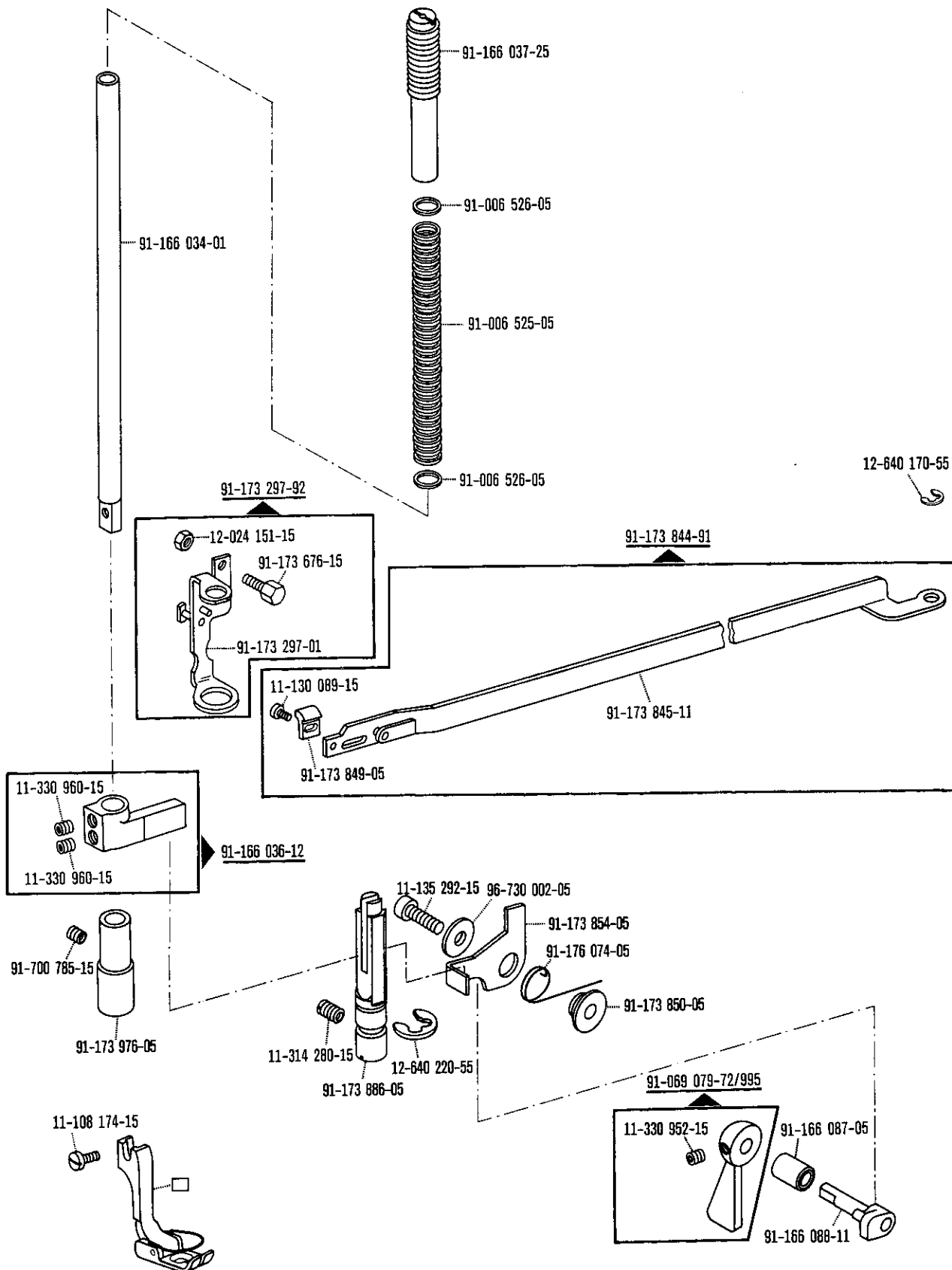

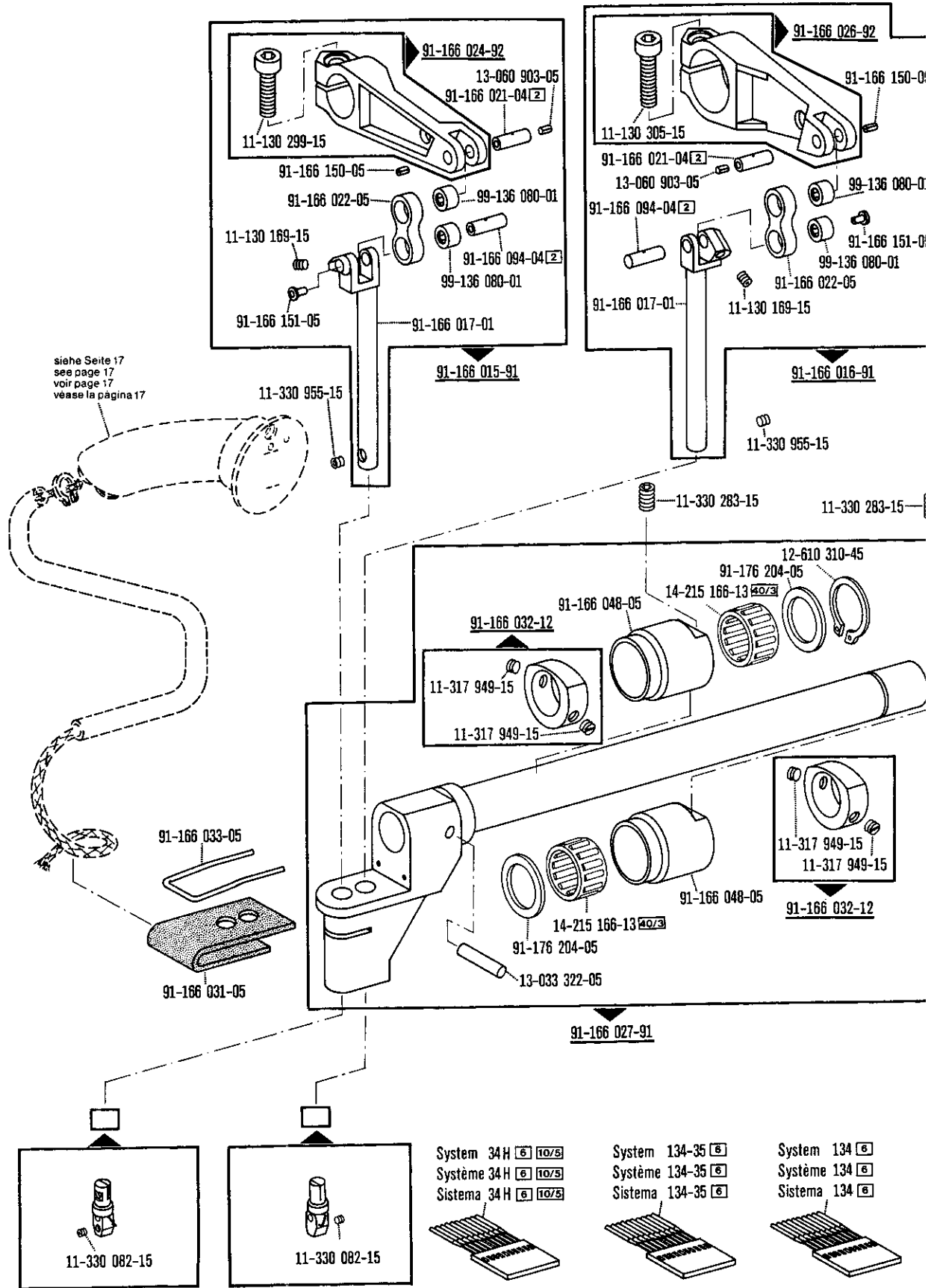

2

Arm parts
Pièces de bras Pfaff 422-720/04
Piezas del brazo Pfaff 1422-720/04

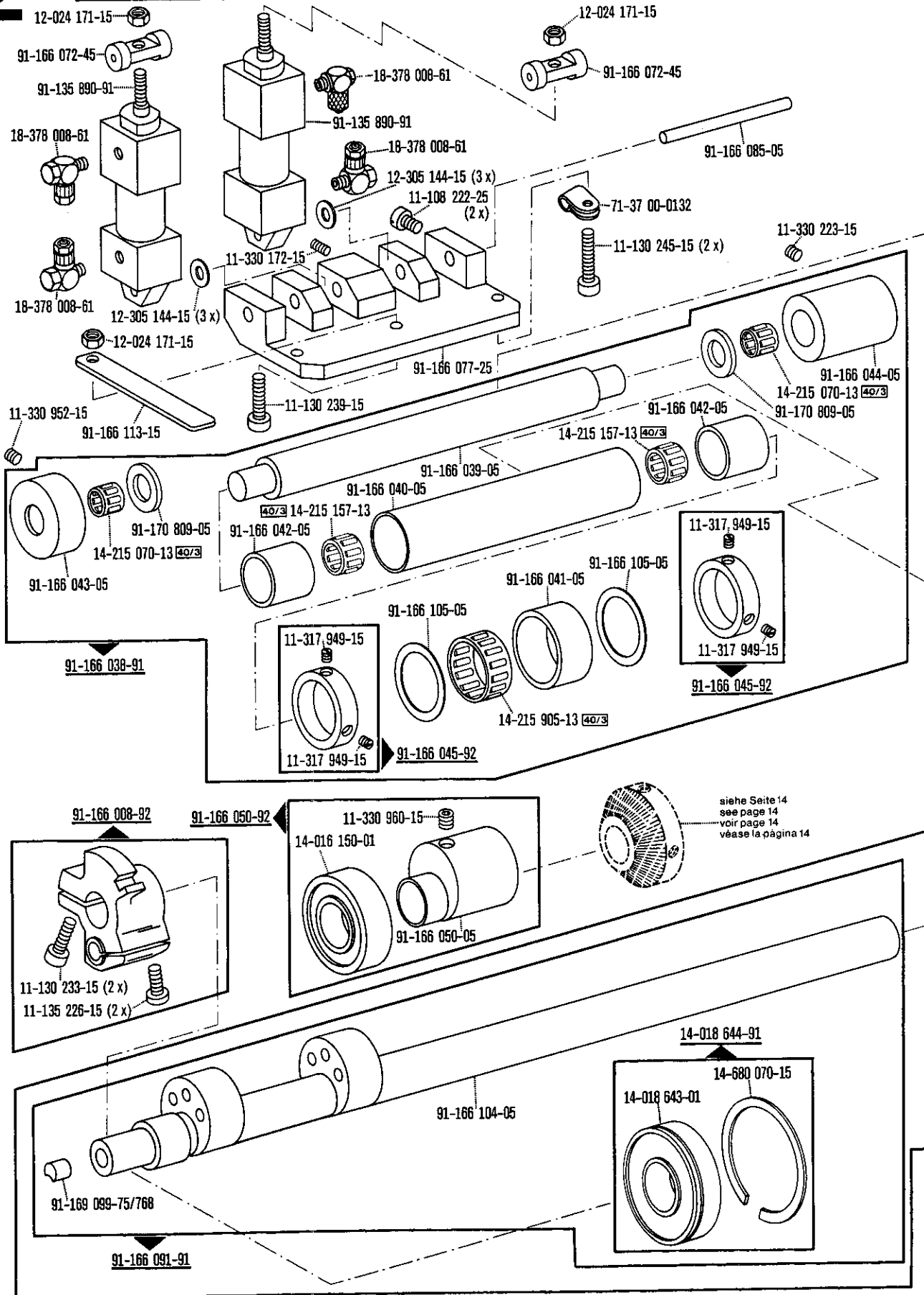

siehe Seite 14
 see page 14
 voir page 14
 véase la página 14

Arm parts
Pièces de bras Pfaff 422-720/04
Piezas del brazo Pfaff 1422-720/04

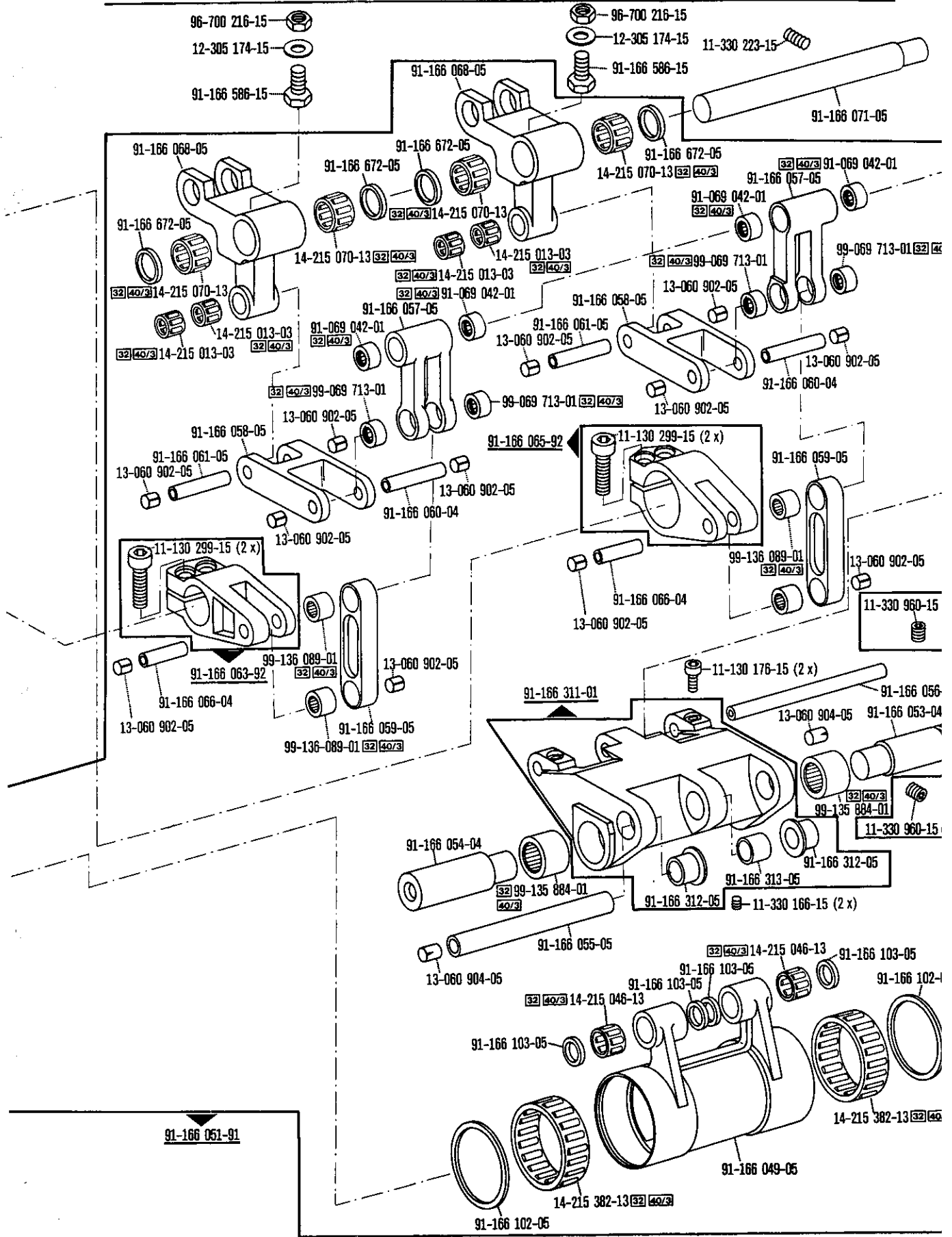

2

Arm parts
 Pièces de bras Pfaff 422-720/04
 Piezas del brazo Pfaff 1422-720/04

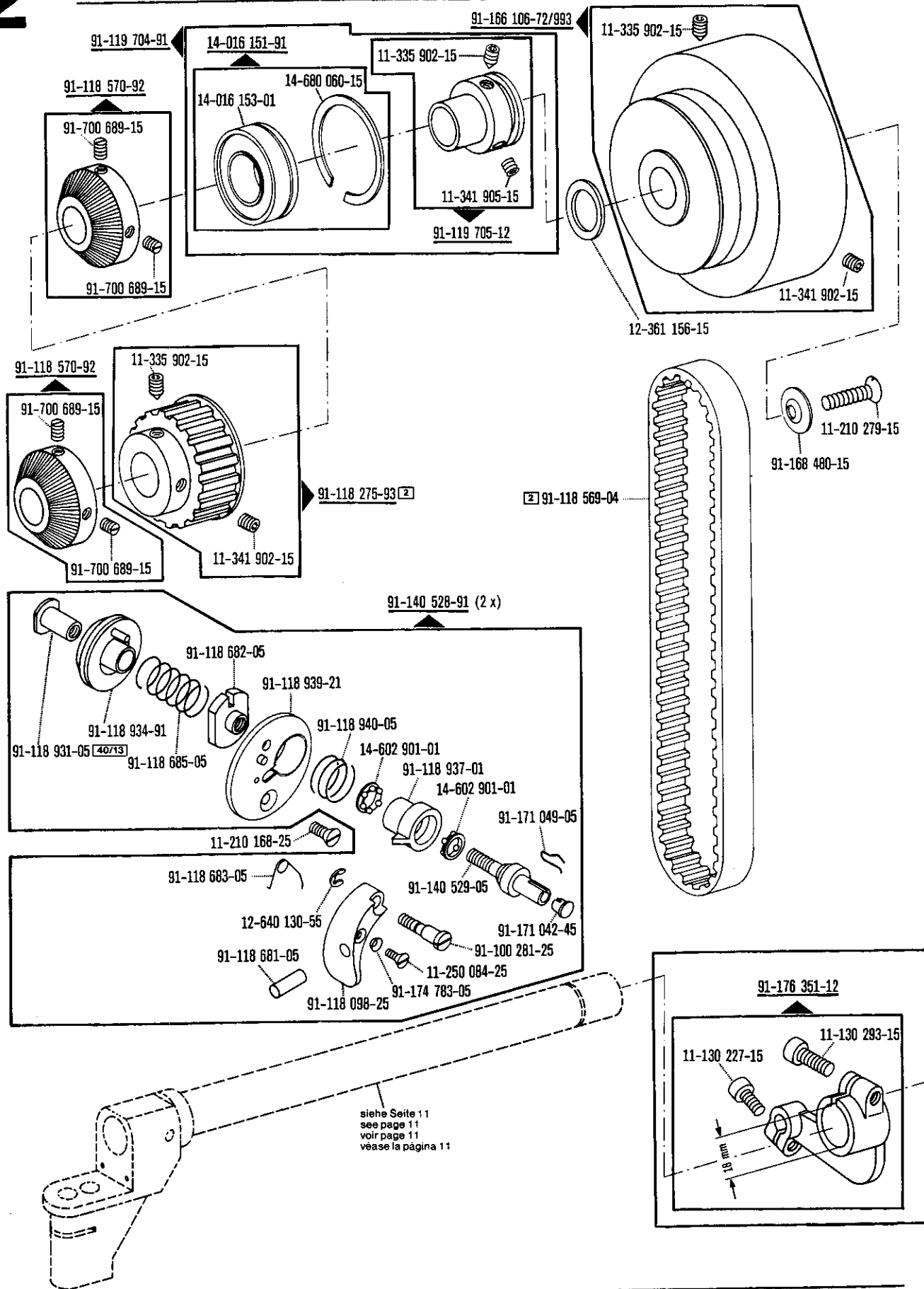

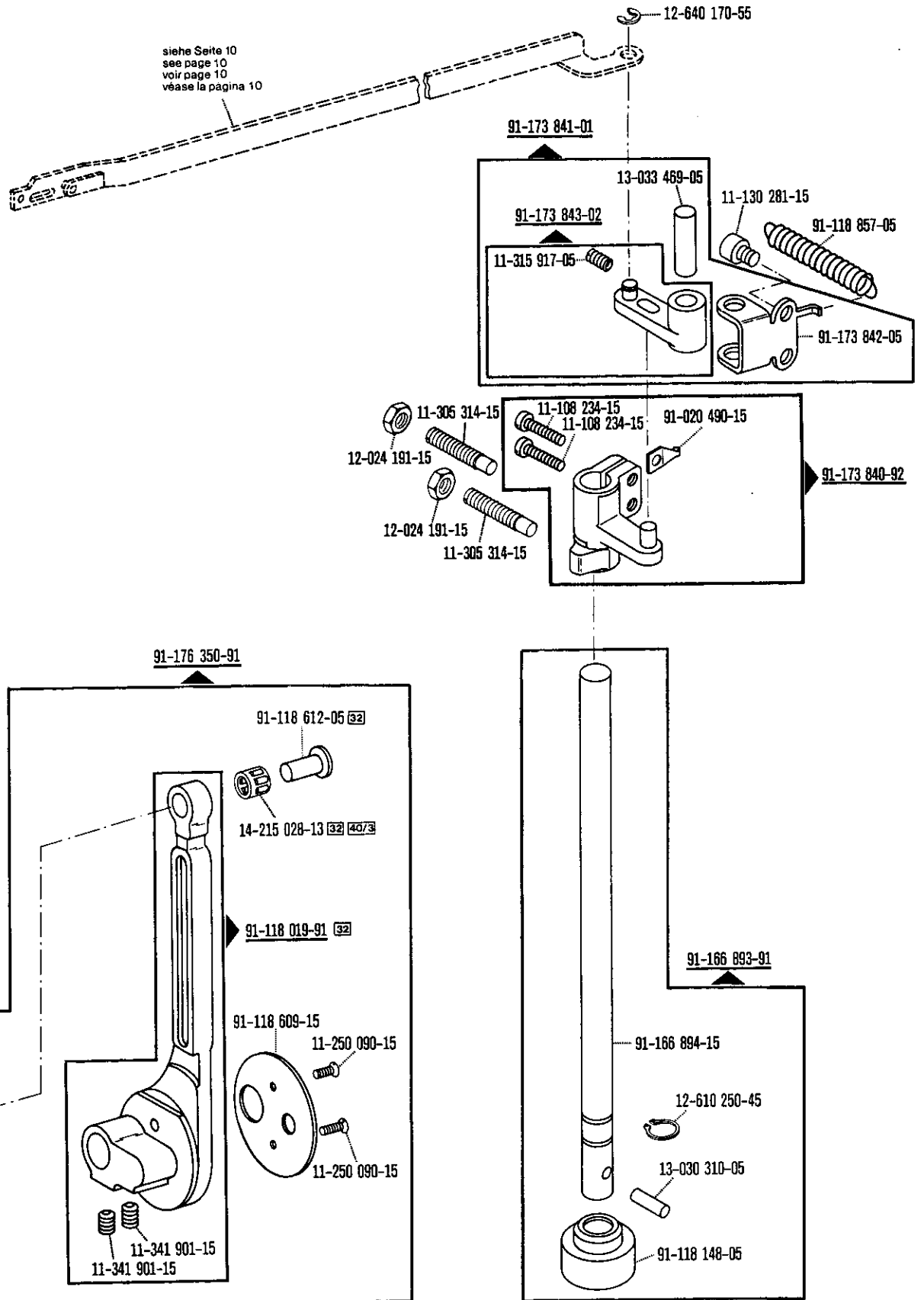

2

Pièces de bras Pfaff 422-720/04
 Piezas del brazo Pfaff 1422-720/04

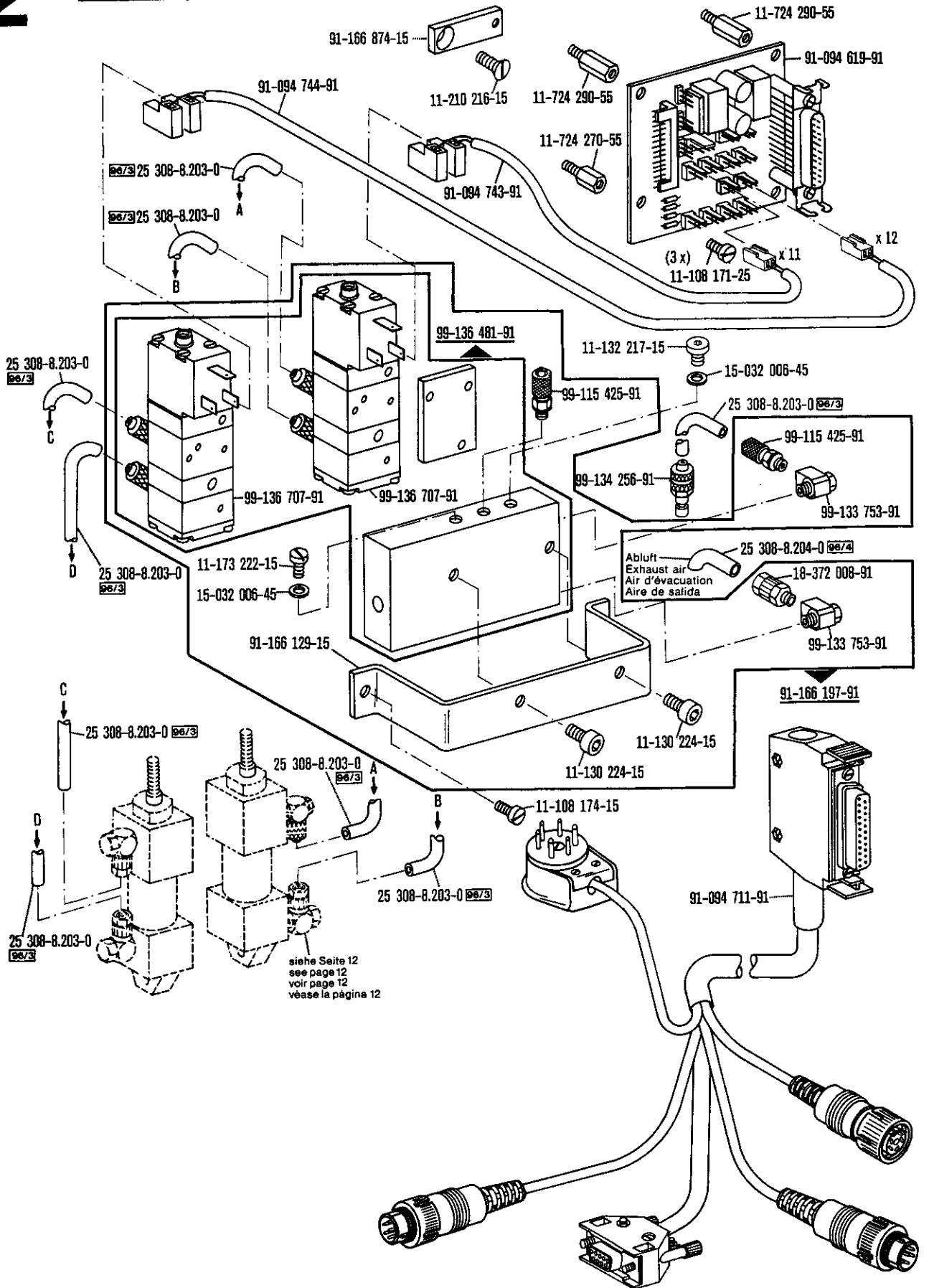

Arm parts
Pièces de bras Pfaff 422-720/04
Piezas del brazo Pfaff 1422-720/04

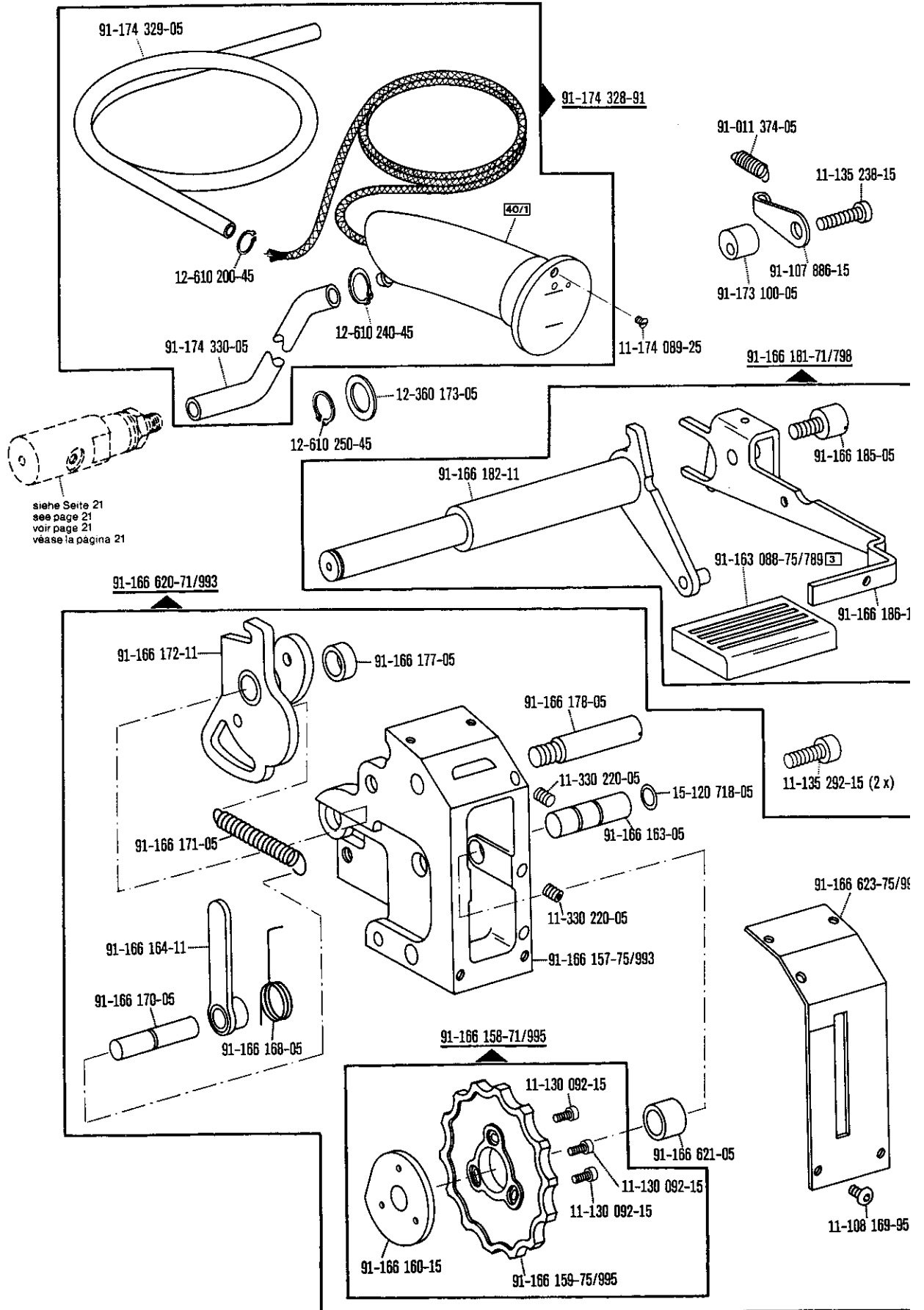

siehe Seite 21
 see page 21
 voir page 21
 véase la página 21

3

appropriate parts
 Pièces du plateau fondamental Pfaff 422-720/04
 Piezas de la placa-base Pfaff 1422-720/04

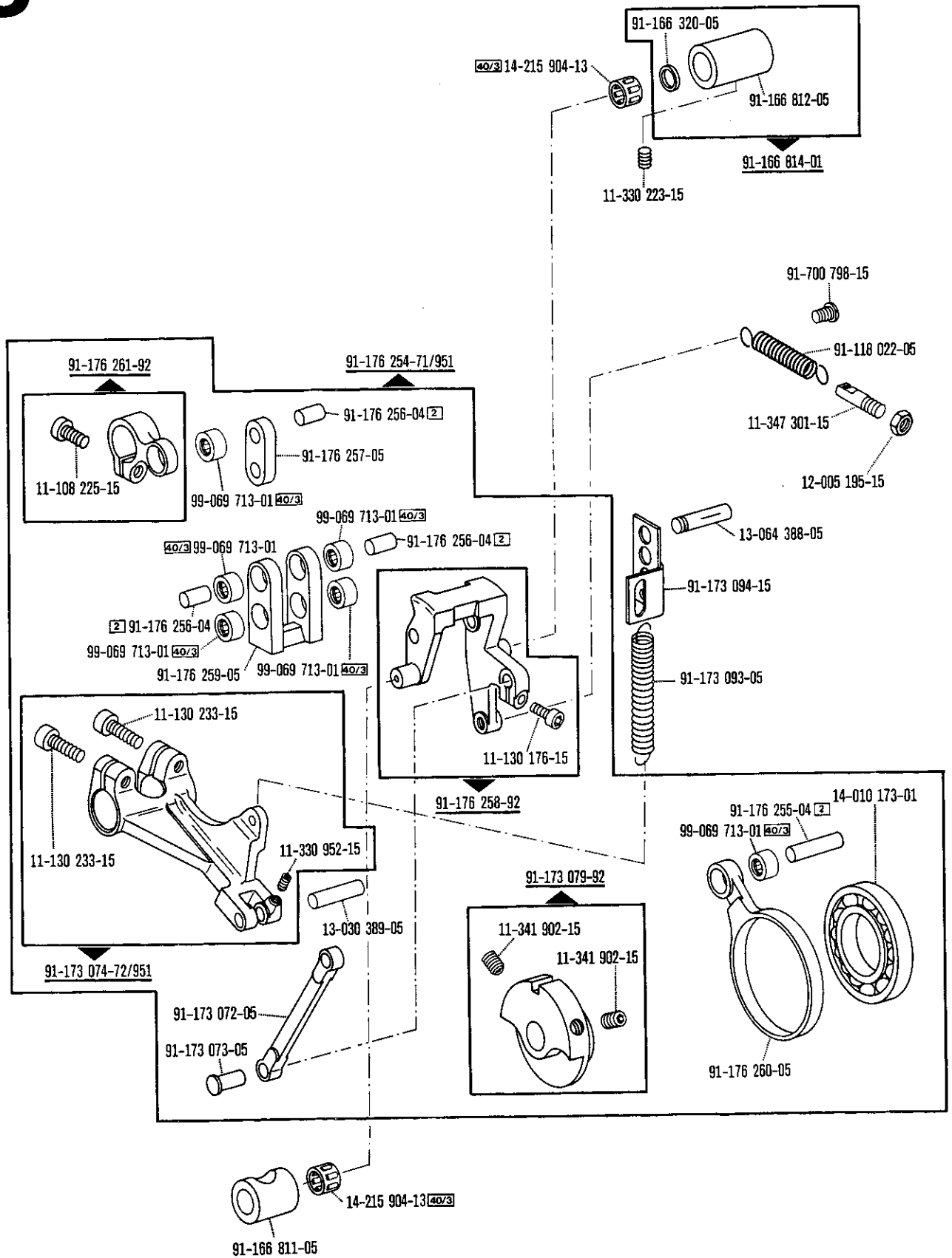

Bedplate parts
Pièces du plateau fondamental Pfaff 422-720/04
Piezas de la placa-base Pfaff 1422-720/04

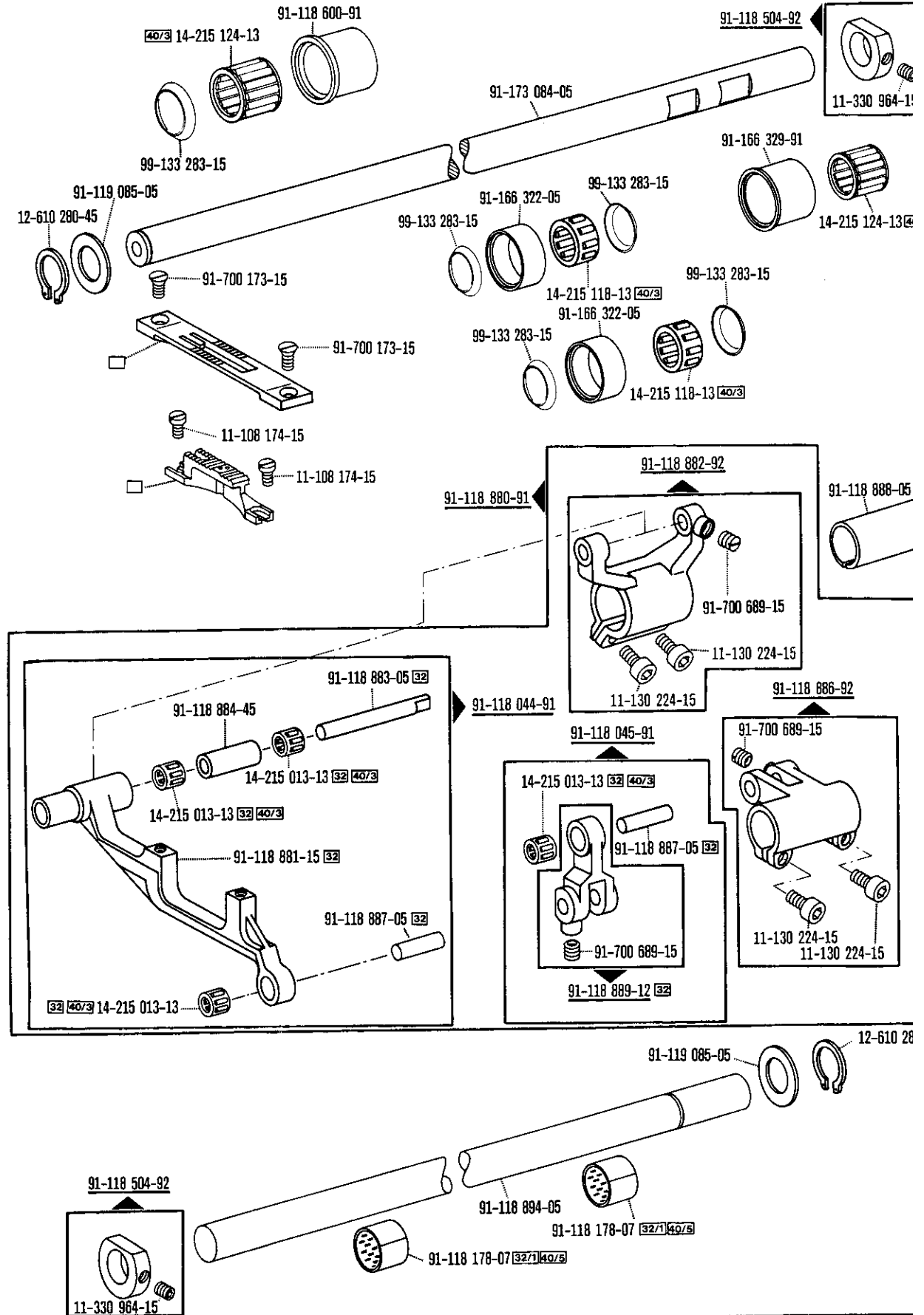

☐ siehe Erläuterungen Register 0

3

Bedplate parts
Pièces du plateau fondamental Pfaff 422-720/04
Piezas de la placa-base Pfaff 1422-720/04

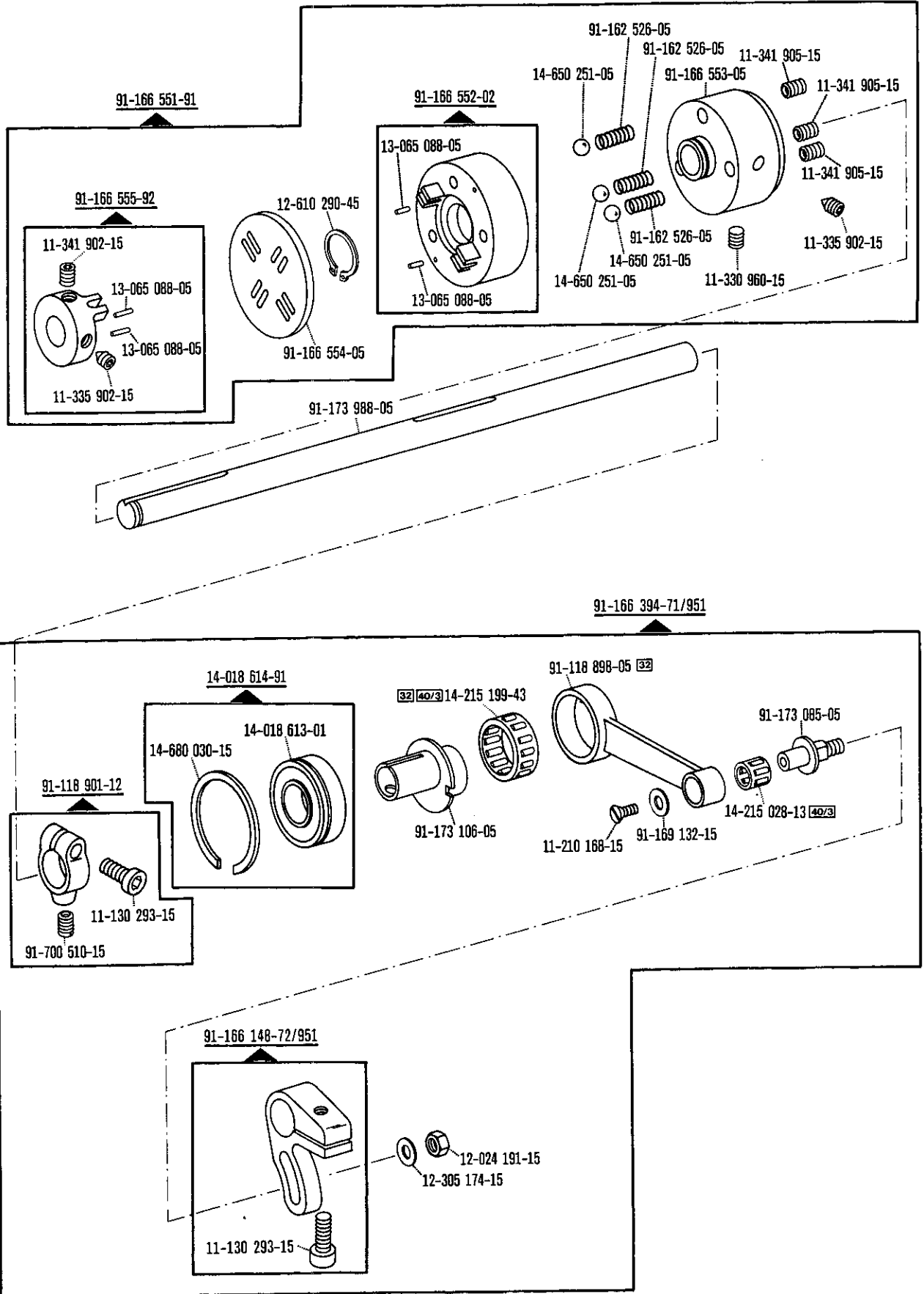

Bedplate parts
Pièces du plateau fondamental Pfaff 422-720/04
Piezas de la placa-base Pfaff 1422-720/04

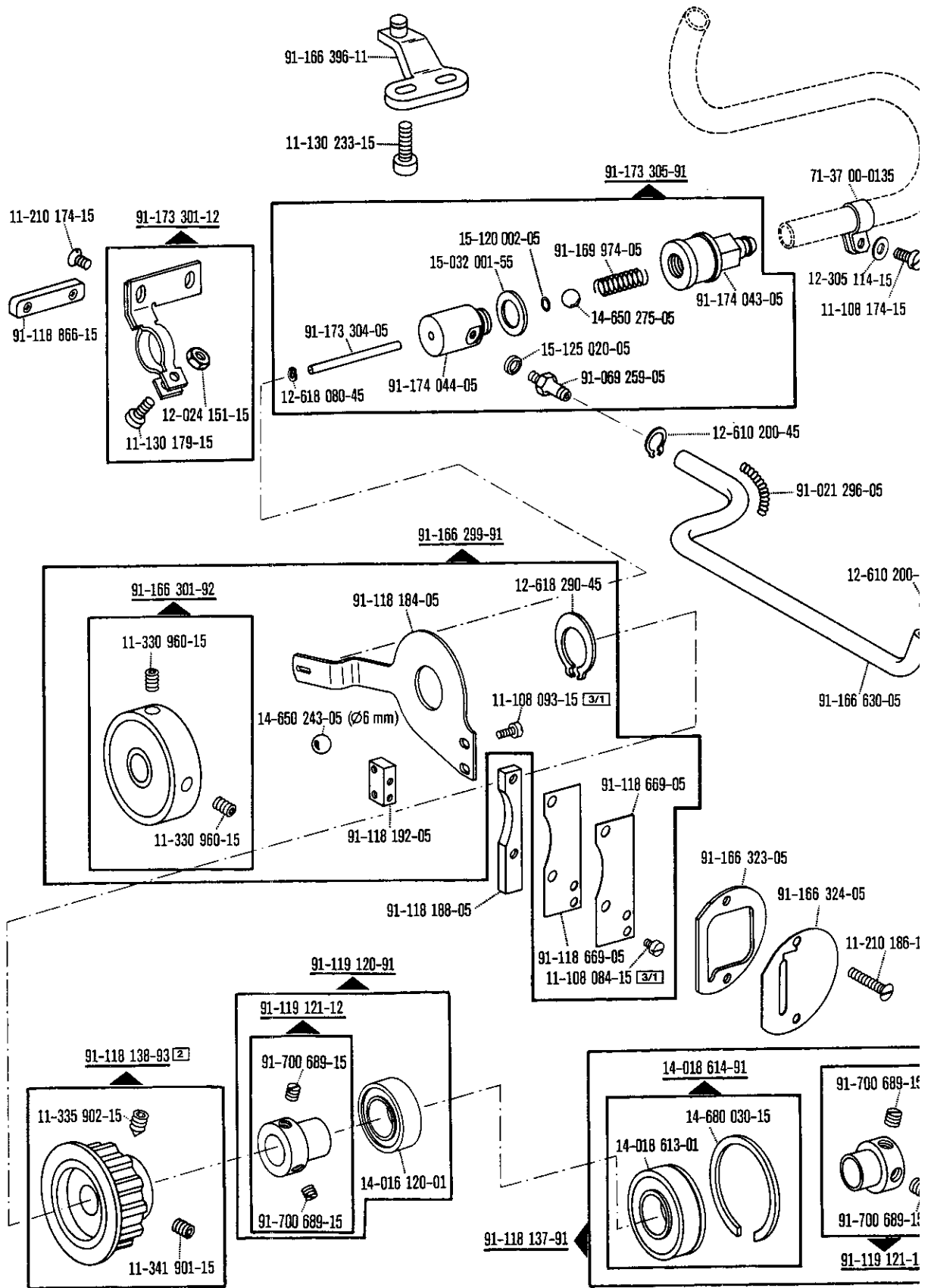

3

Bedplate parts
Pièces du plateau fondamental
Piezas de la placa-base

Pfaff 422-720/04

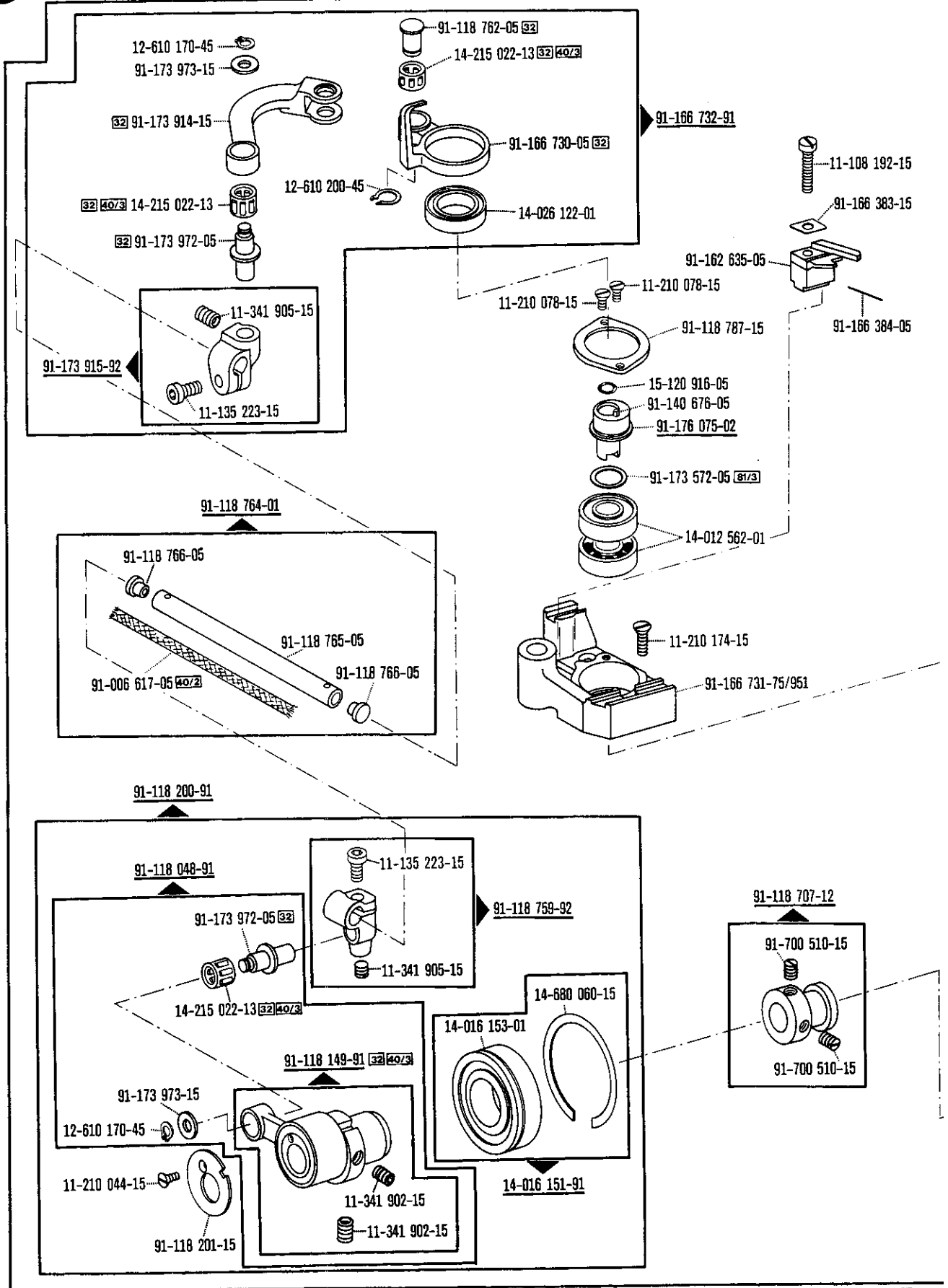

Bedplate parts
Pièces du plateau fondamental
Piezas de la placa-base

Pfaff 422-720/04

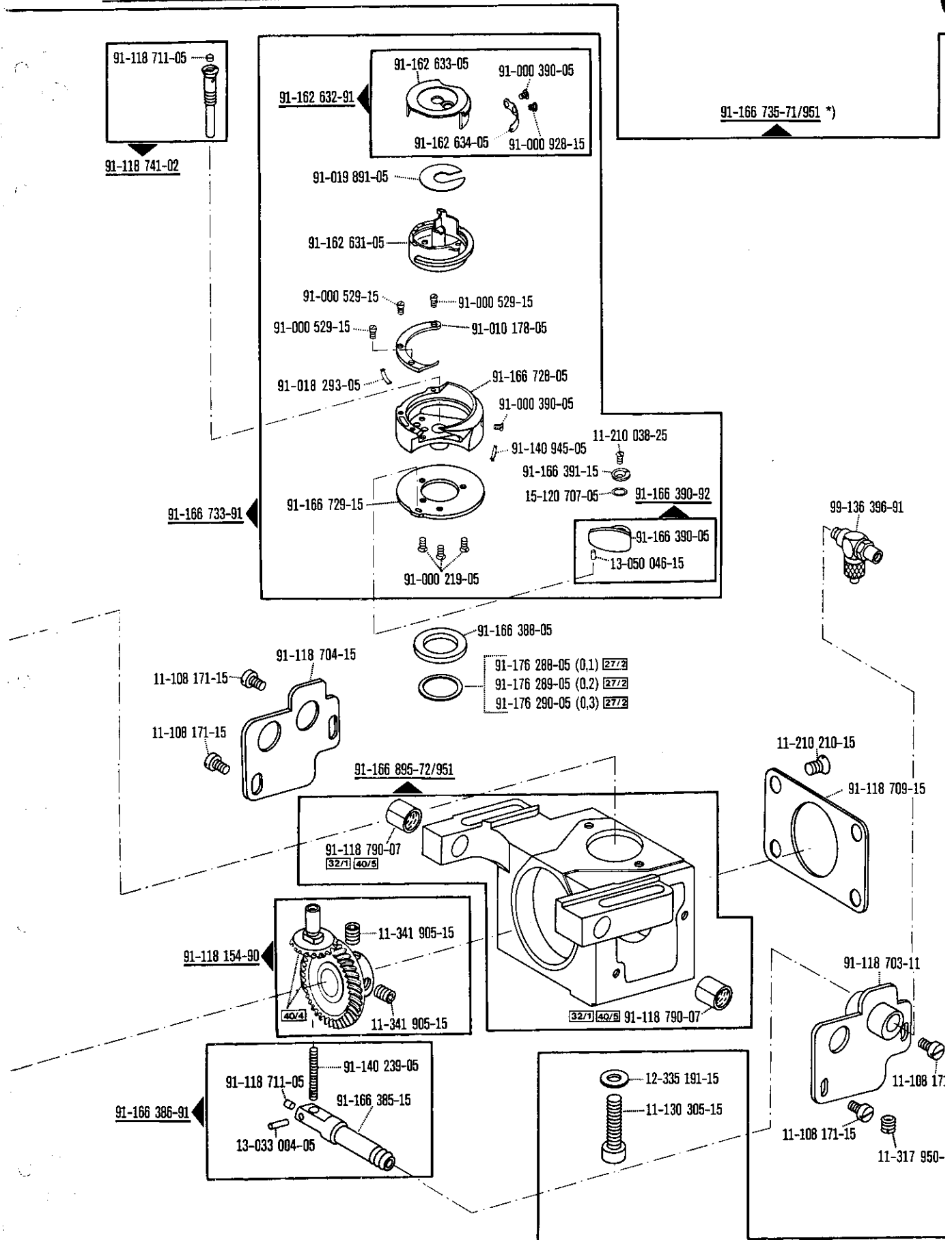

☐ siehe Erläuterungen Register 0
see explanations in section 0

*) Gruppenteilnummer beinhaltet die Seiten 22, 23, 24, 25
Group part number applies to pages 22, 23, 24, 25

3

Bedplate parts Pièces du plateau fondamental Piezas de la placa-base

Pfaff 422-720/04

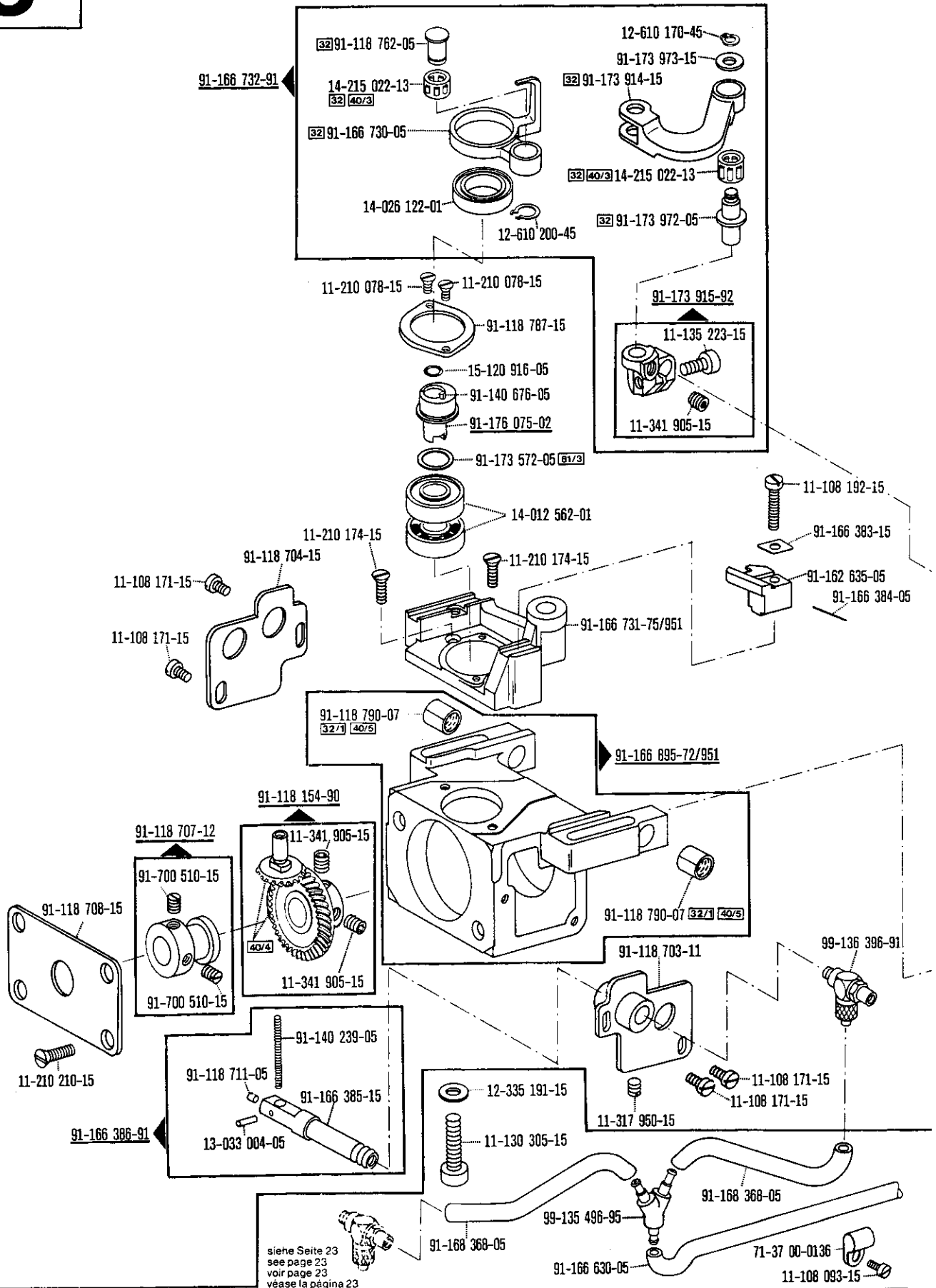

siehe Seite 23
see page 23
voir page 23
véase la página 23

☐ siehe Erläuterungen Register 0
see explanations in section 0

Bedplate parts
Pièces du plateau fondamental
Piezas de la placa-base

Pfaff 422-720/04

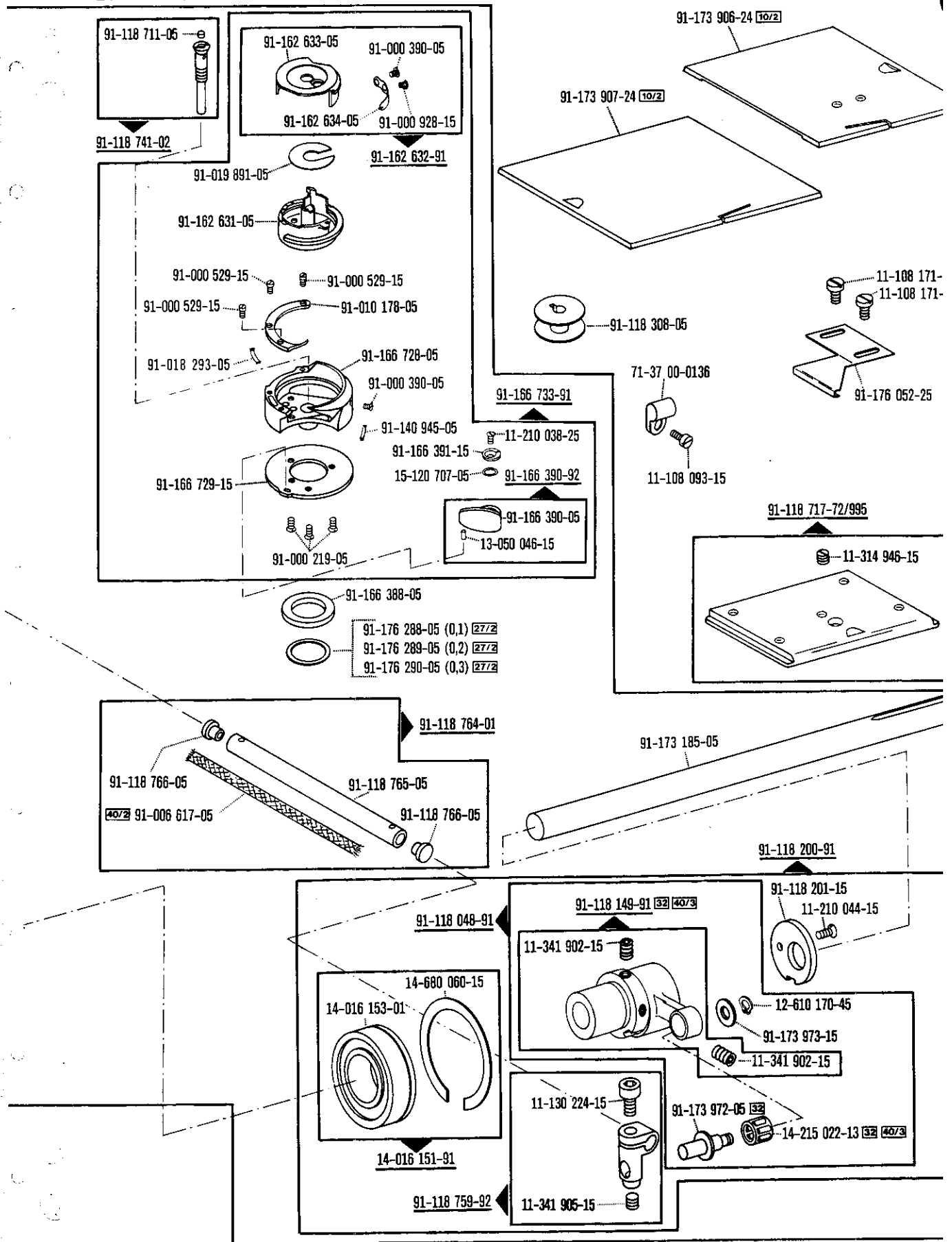

☐ siehe Erläuterungen Register 0
 see explanations in section 0

3

Complete parts
Pièces du plateau fondamental
Piezas de la placa-base

Pfaff 1422-720/04

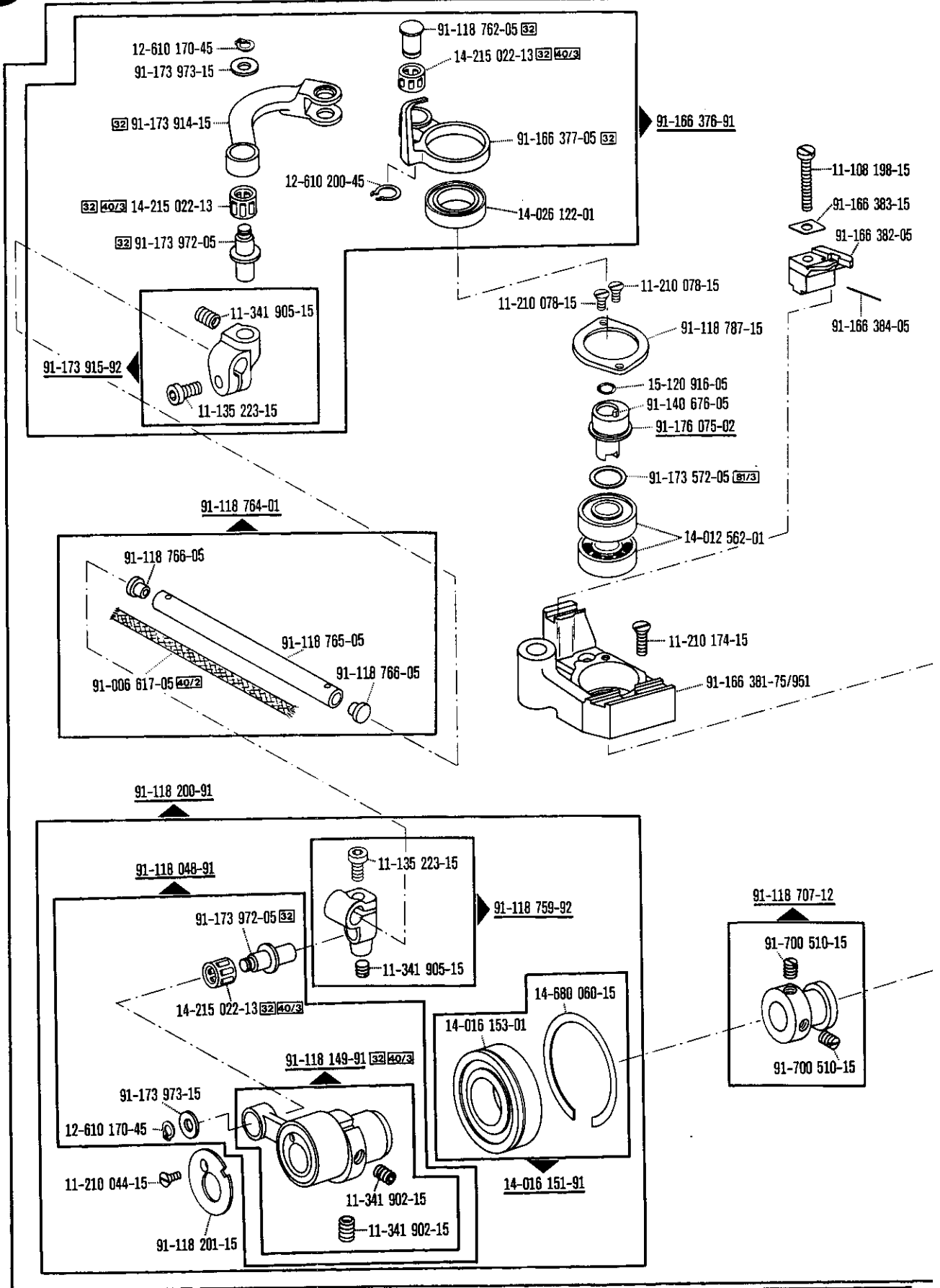

Beachte parts
Pièces du plateau fondamental
Piezas de la placa-base

Pfaff 1422-720/04

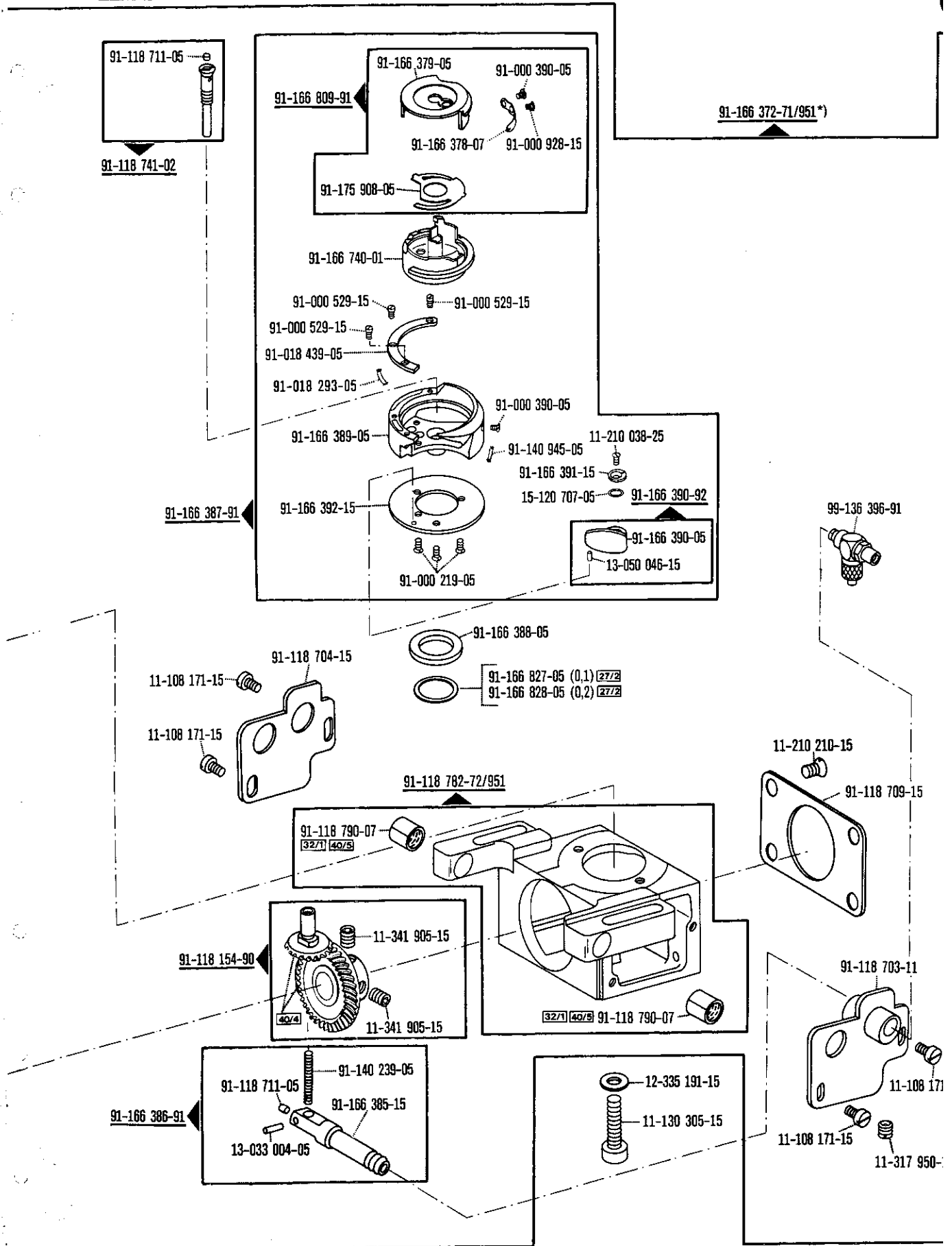

☐ siehe Erläuterungen Register 0
 see explanations in section 0

*) Gruppenteilnummer beinhaltet die Seiten 26, 27, 28, 29
 Group part number ... applies to pages 26, 27, 28, 29

3

Bedplate parts
Pièces du plateau fondamental
Piezas de la placa-base

Pfaff 1422-720/04

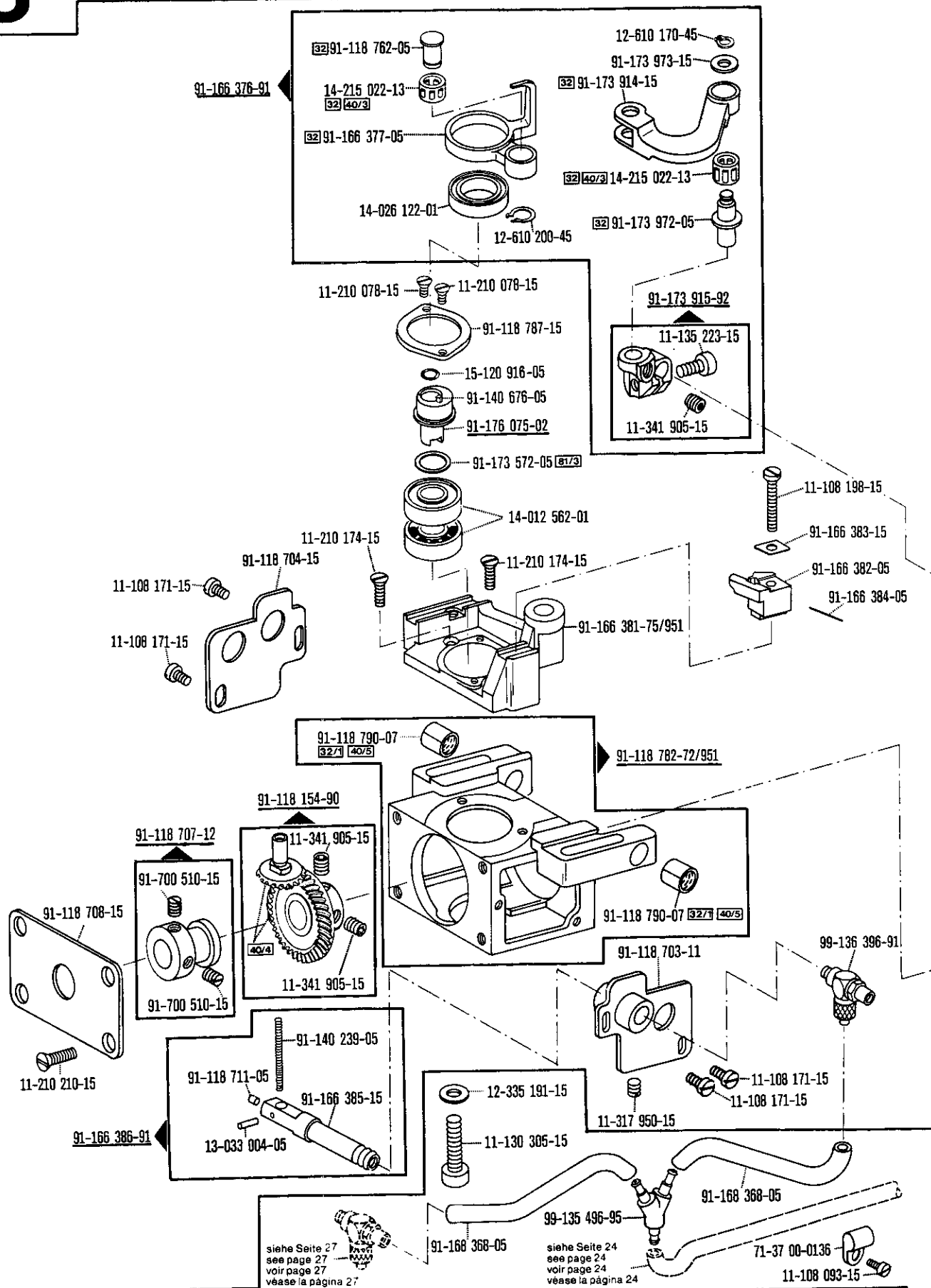

Bedplate parts
 Pièces du plateau fondamental
 Piezas de la placa-base

Pfaff 1422-720/04

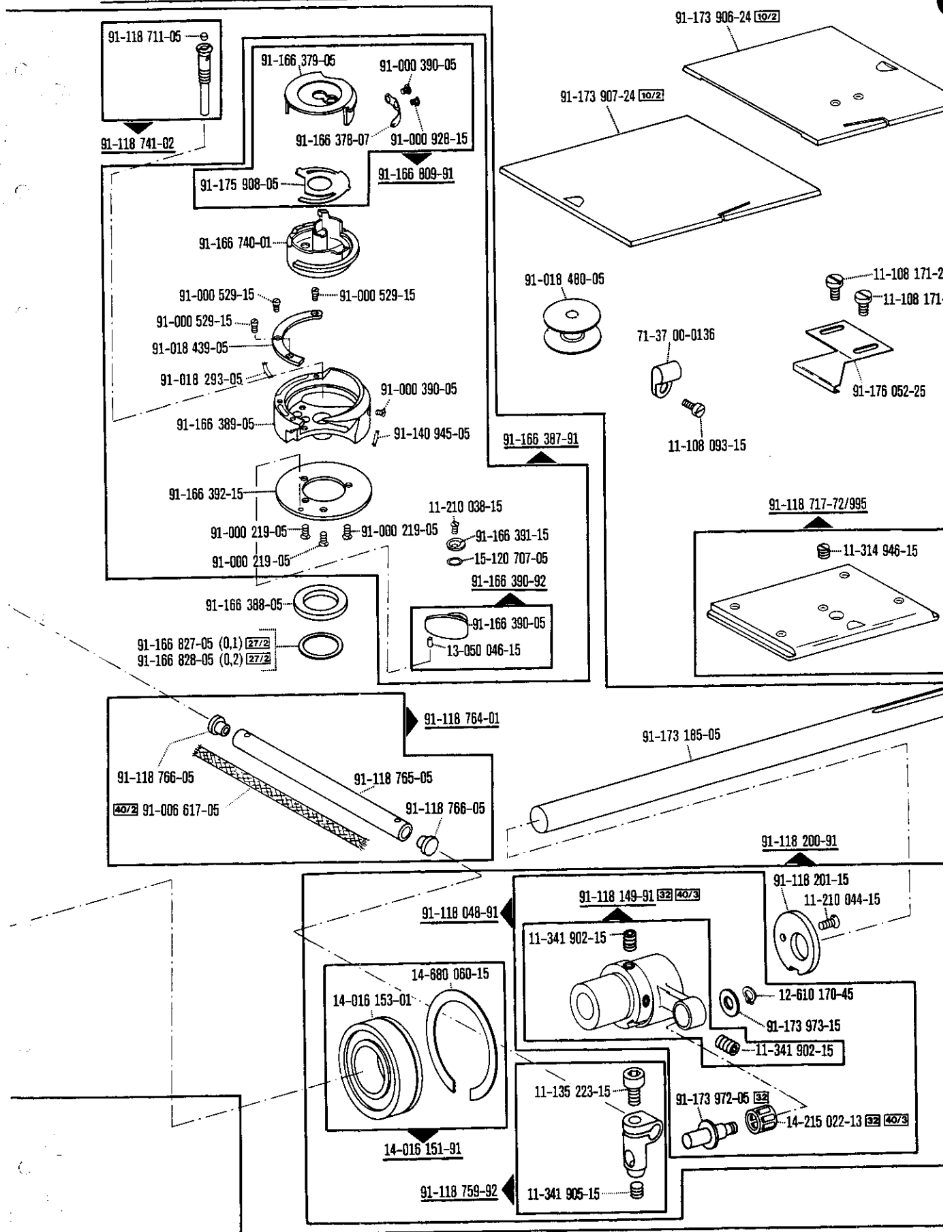

4

housing parts
 Parties du corps Pfaff 422-720/04
 Piezas del cárter Pfaff 1422-720/04

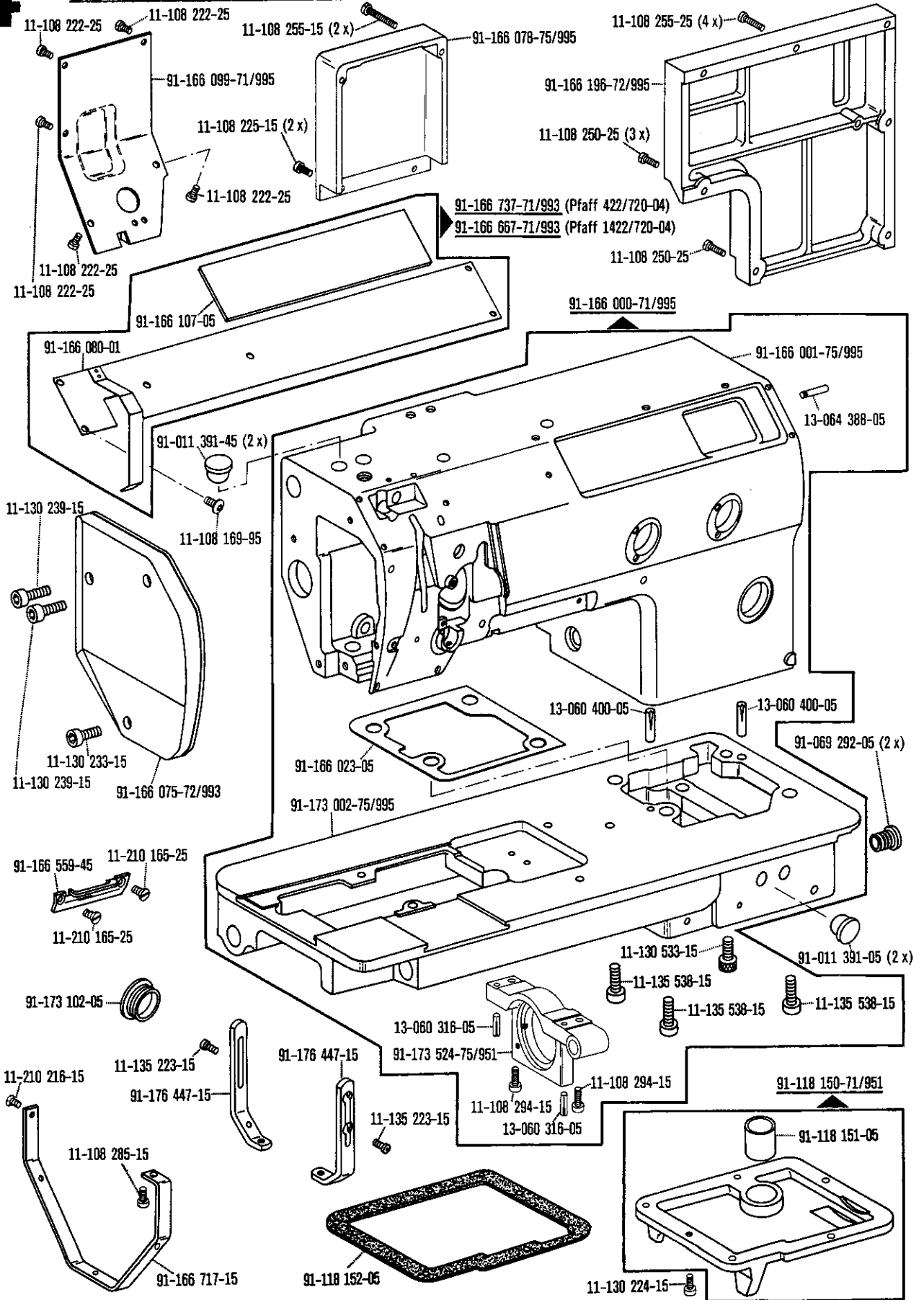

Puller feed
 Puller
 Puller

-748/26

zur - pour
 for - para

Pfaff 422-720/04
 Pfaff 1422-720/04

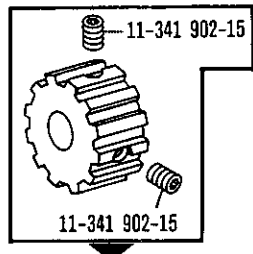

91-178 659-12

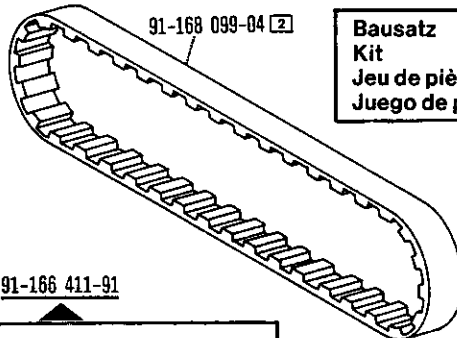

91-166 411-91

Bausatz
 Kit
 Jeu de pièces
 Juego de piezas

-748/26 = No. 91-166 410-70/995

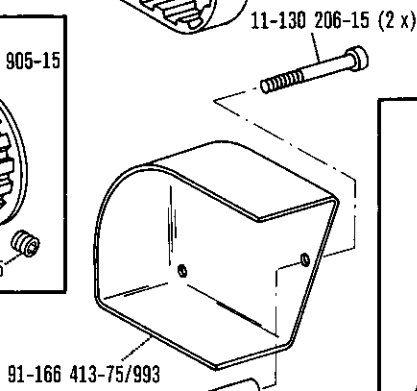
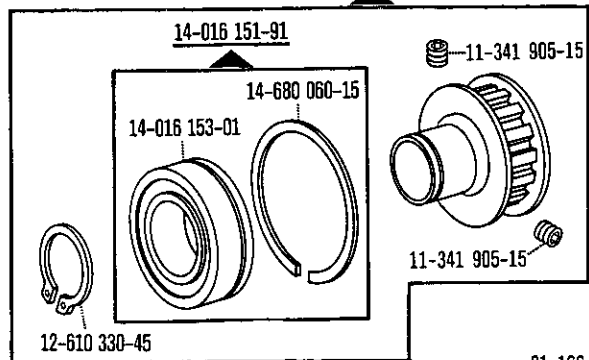

91-166 413-75/993

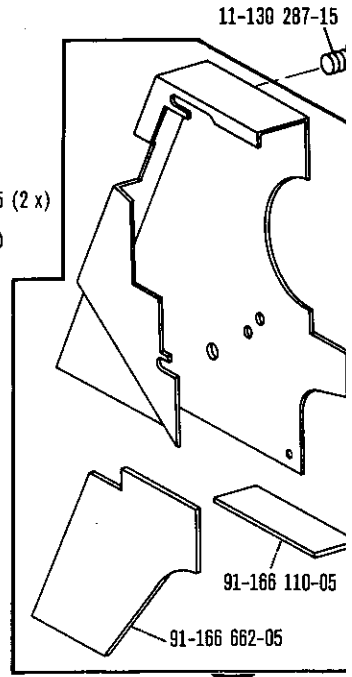

91-166 727-71/993

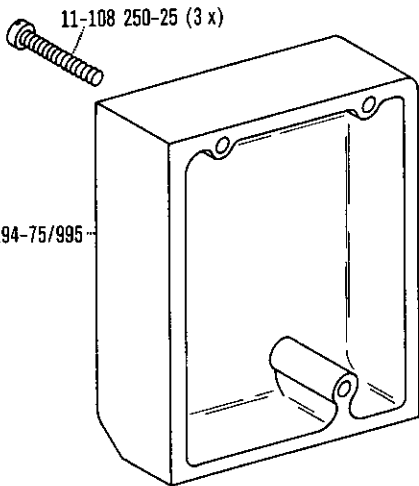

91-166 194-75/995

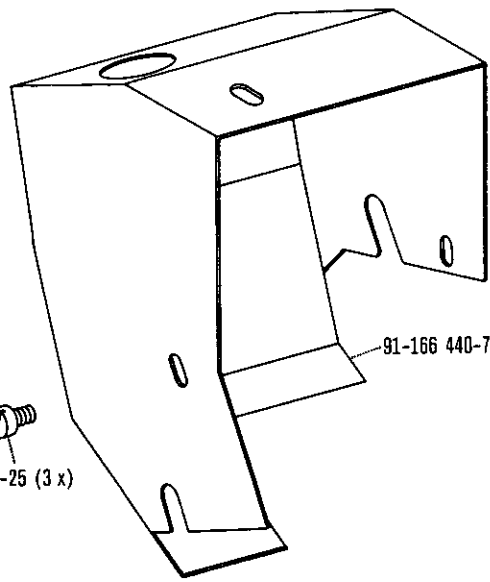
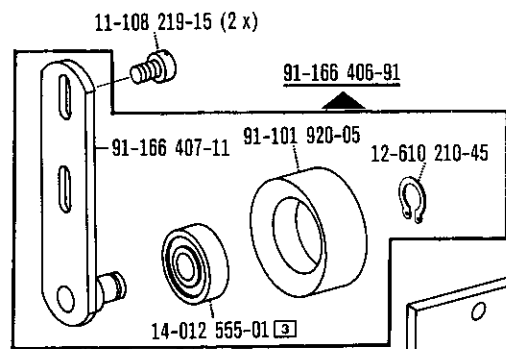

11-108 222-25 (3 x)

91-166 440-71/995

91-166 414-75/995

91-173 049-05

11-108 240-25 (4 x)

5

Puller teed
Puller
Puller

-748/26 zur - pour
for - para

Pfaff 422-720/04
Pfaff 1422-720/04

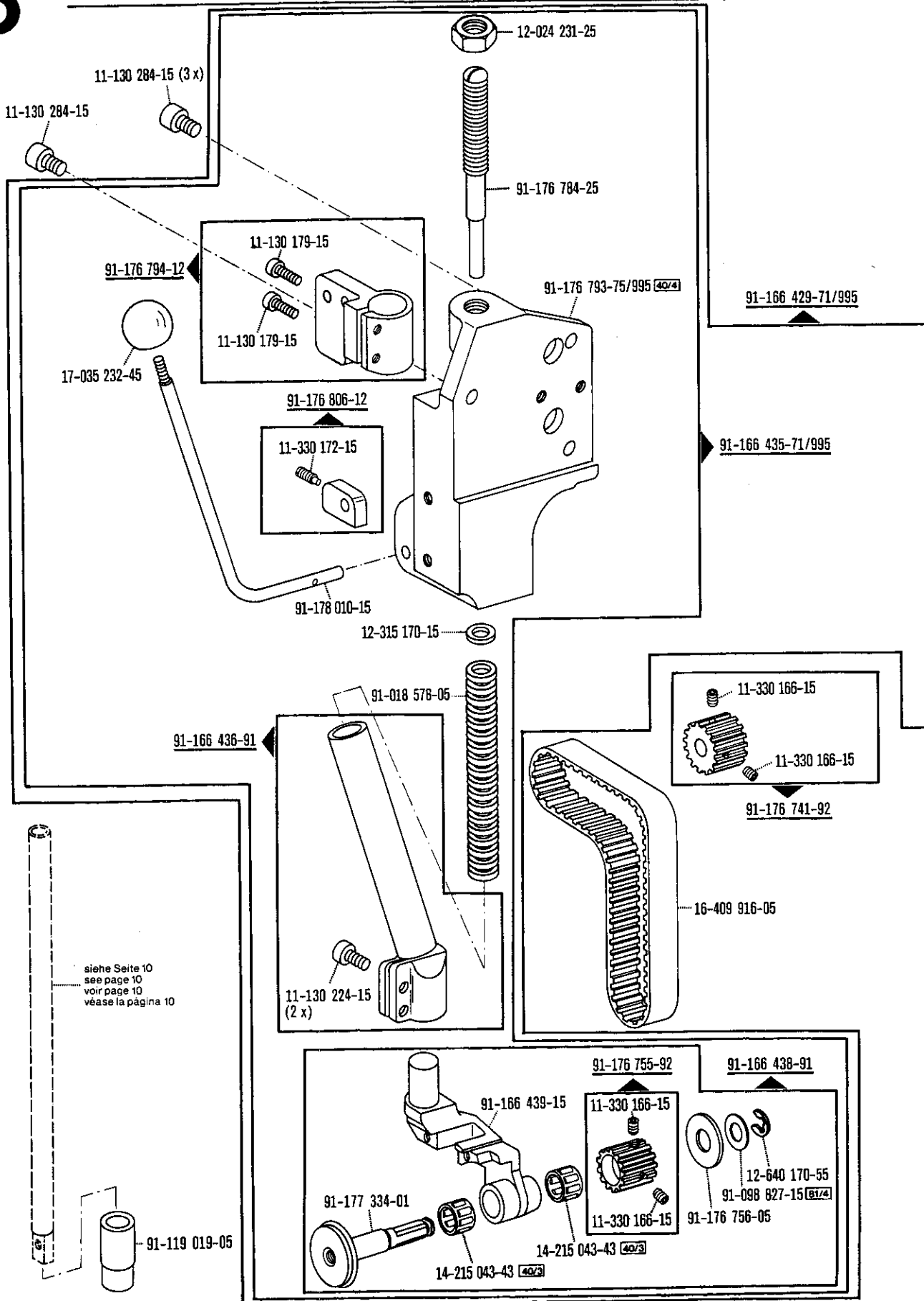

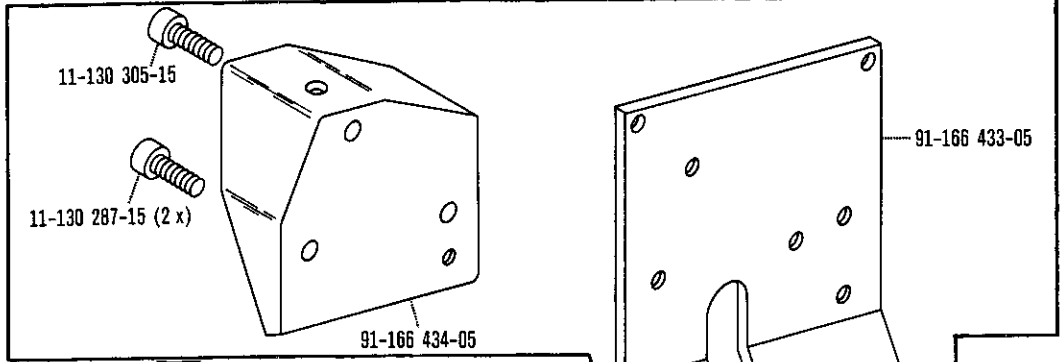

91-166 432-71/995

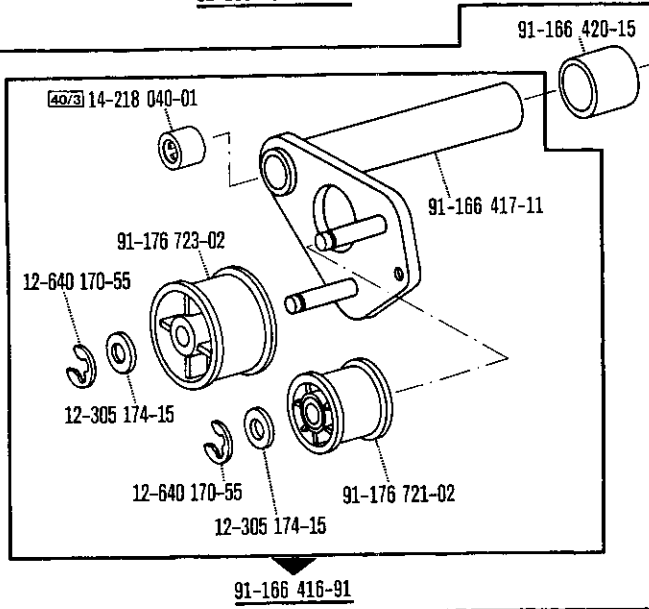

91-166 416-91

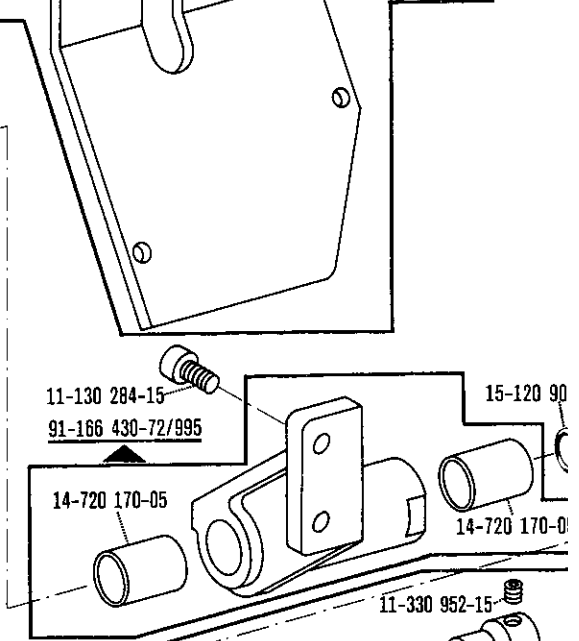

91-166 430-72/995

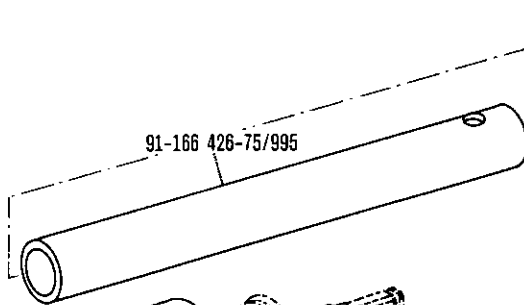

91-166 427-12

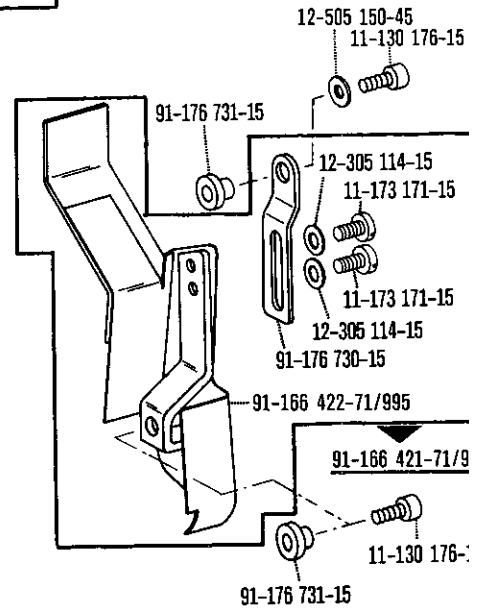
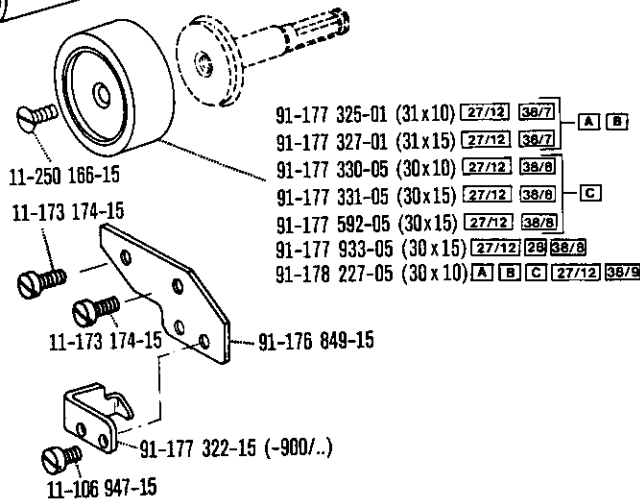

91-176 731-15

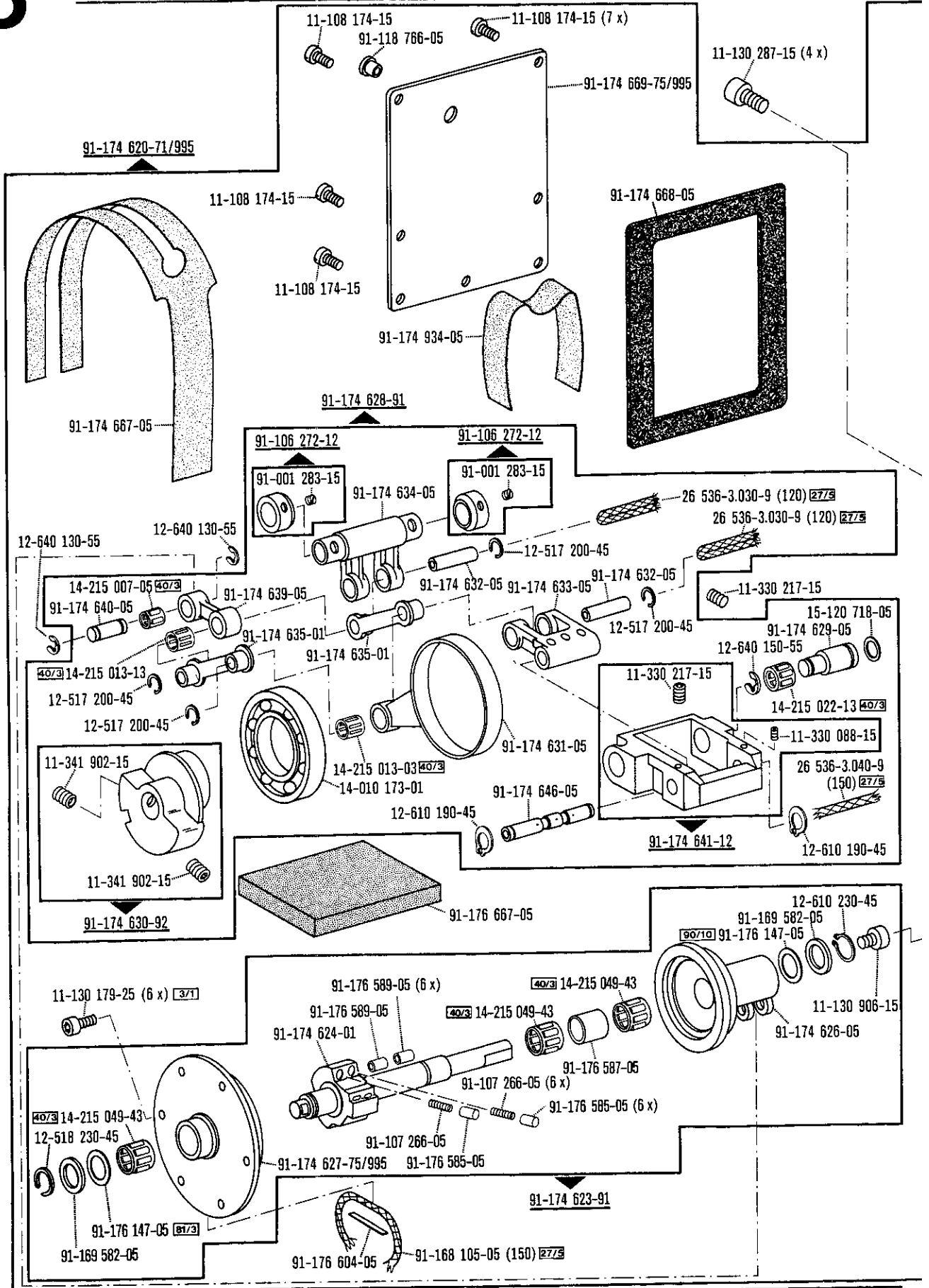

Puller feed
 Puller
 Puller

-748/26 zur pour
 for para Pfaff 422-720/04
 Pfaff 1422-720/04

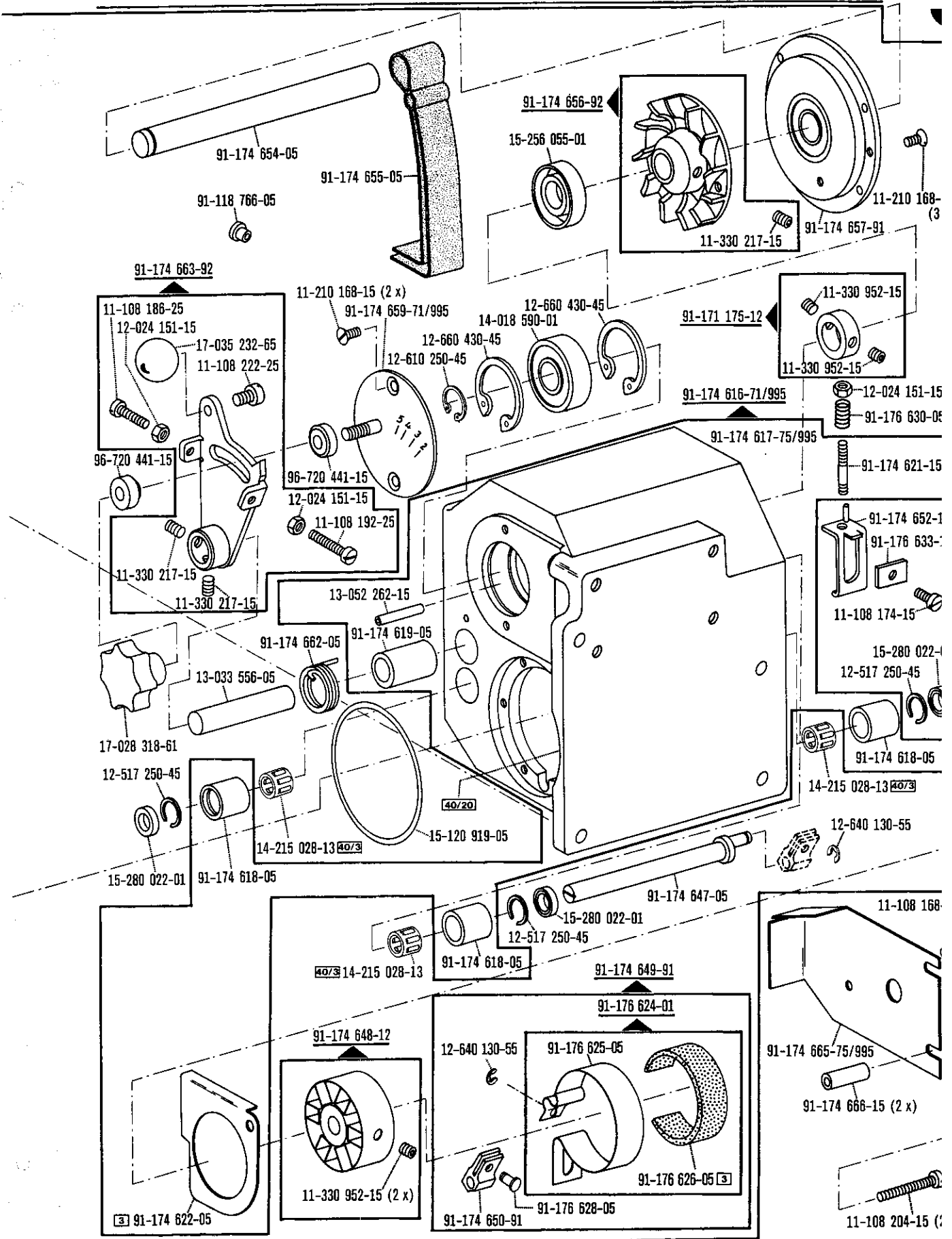

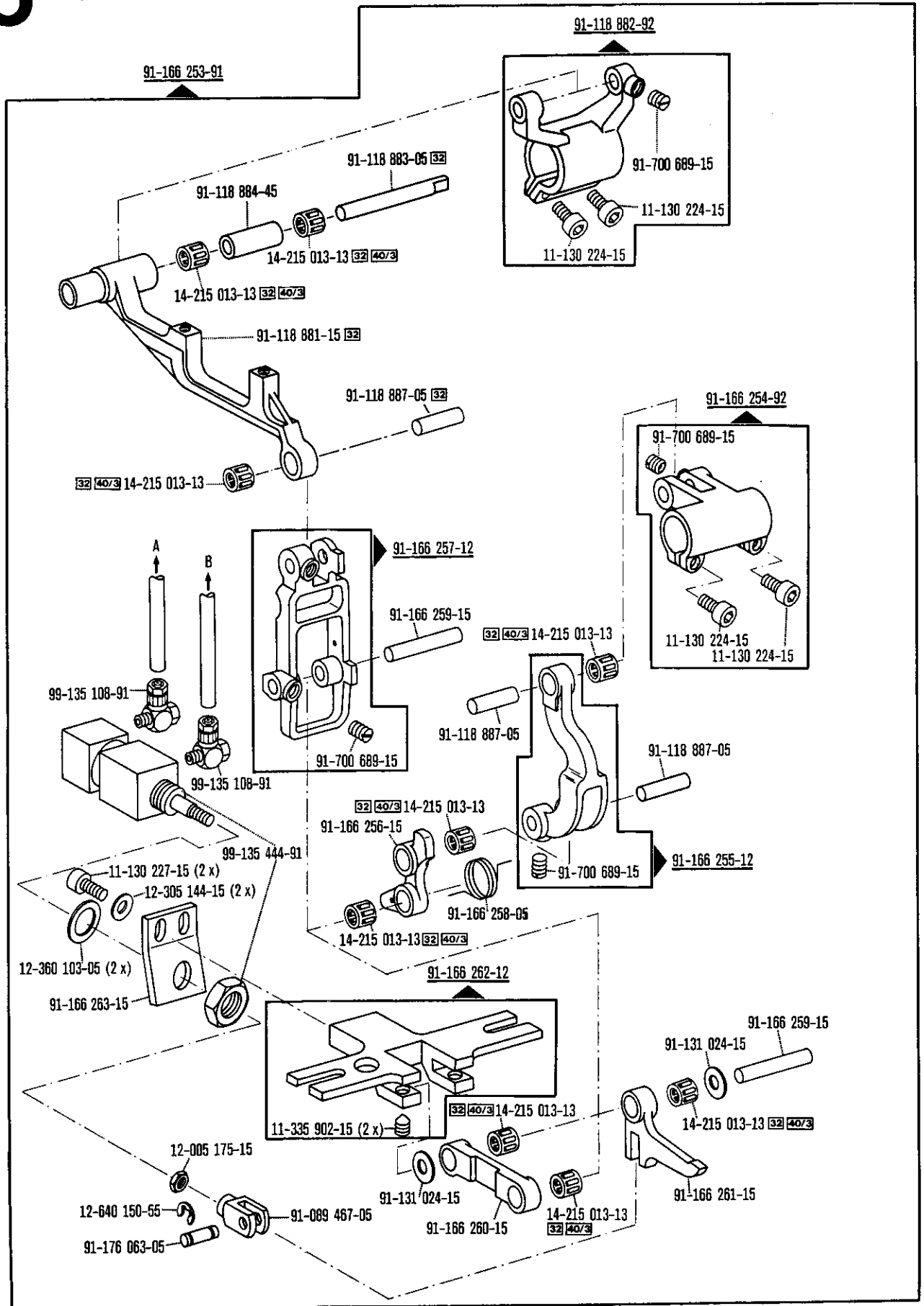

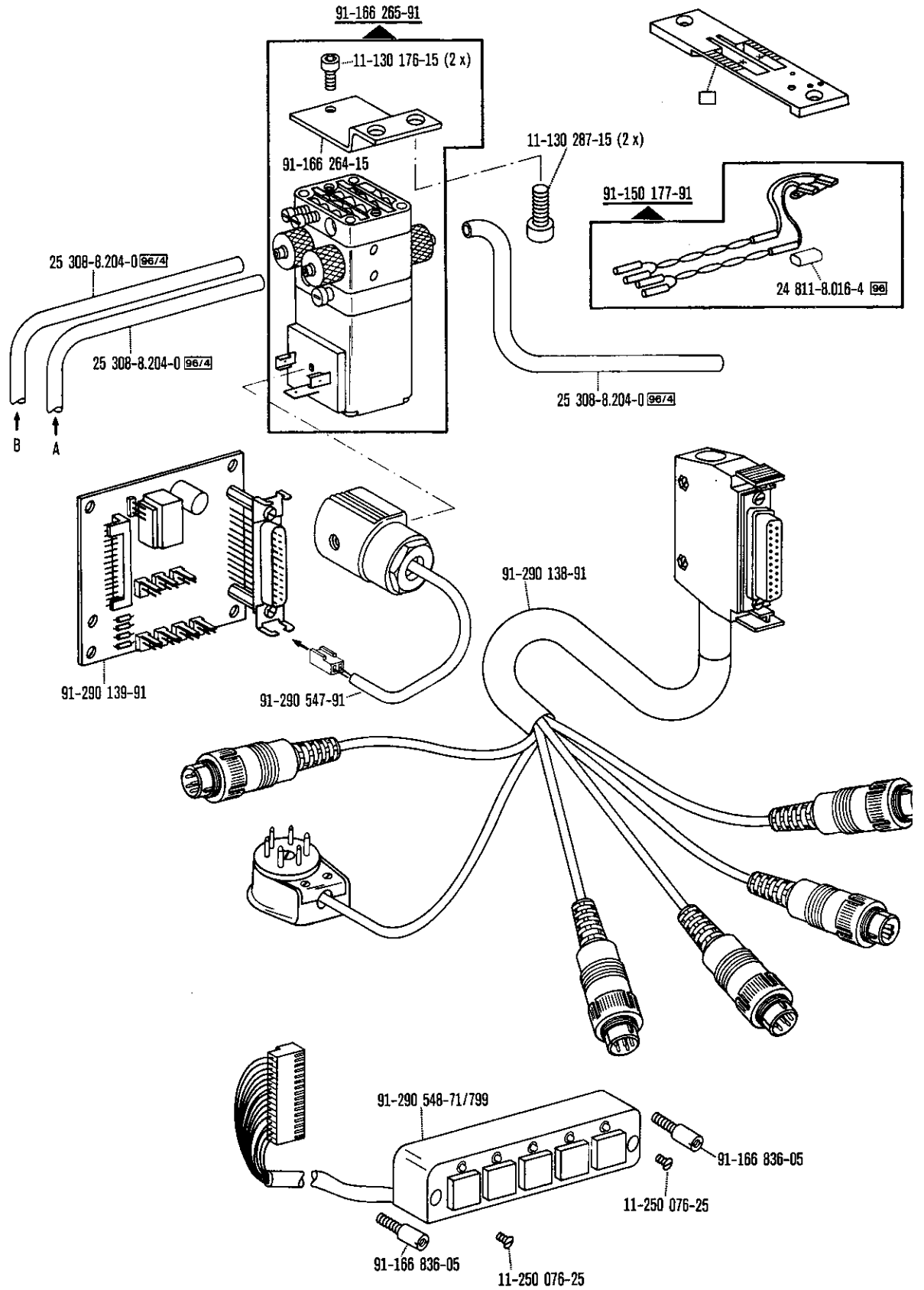

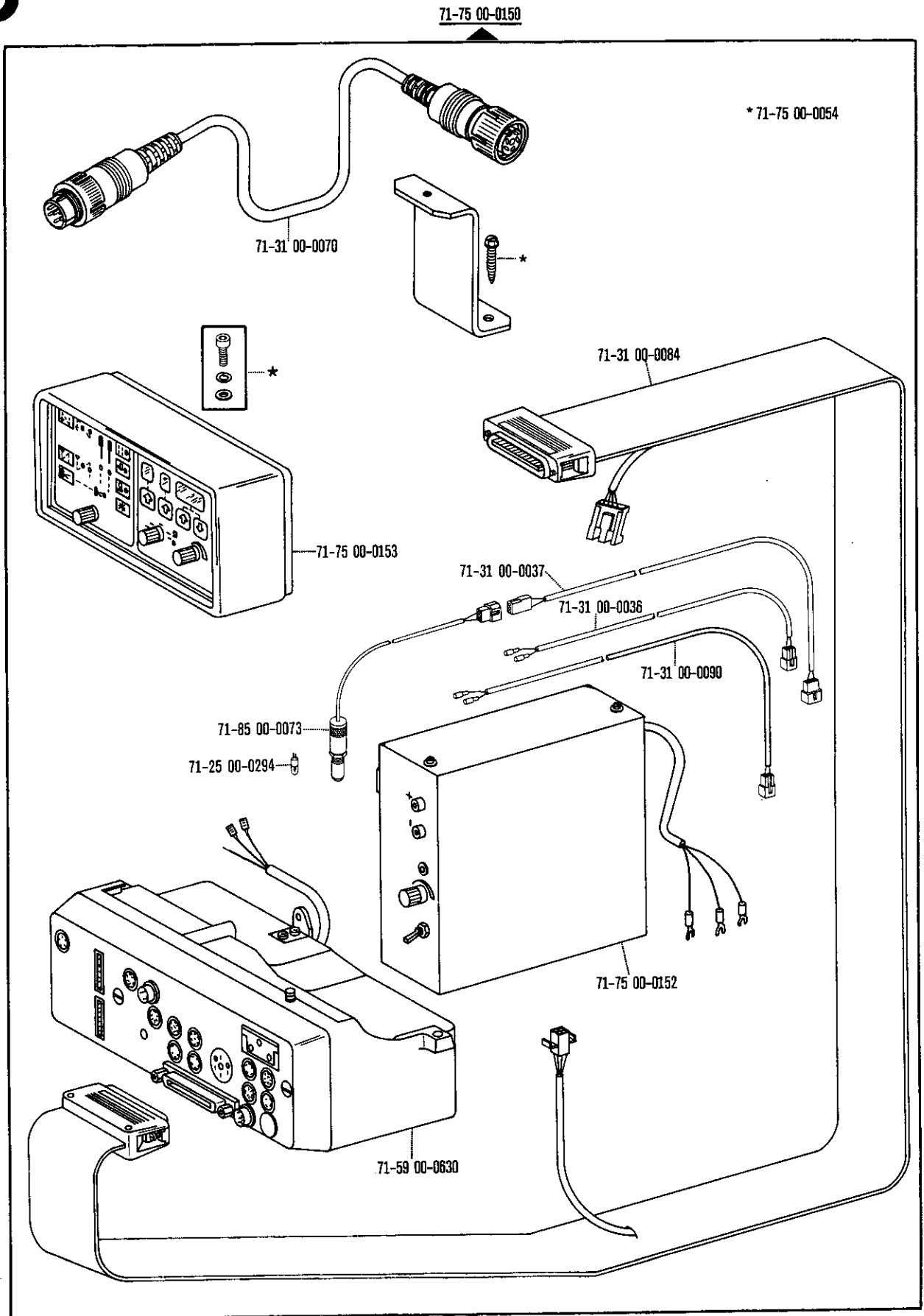

91-090 823-91 [90/38]

91-290 001-91 [90/38]

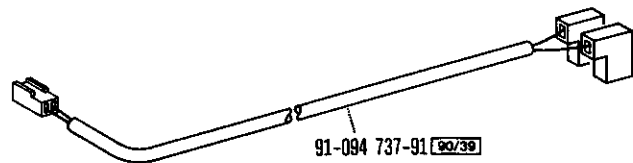
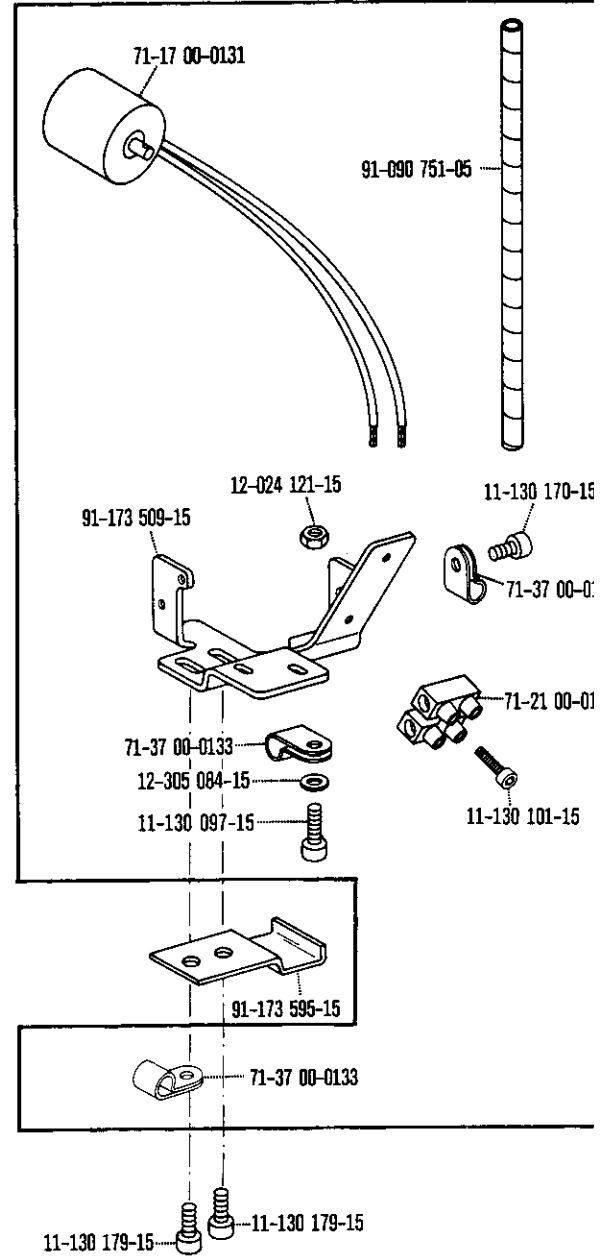
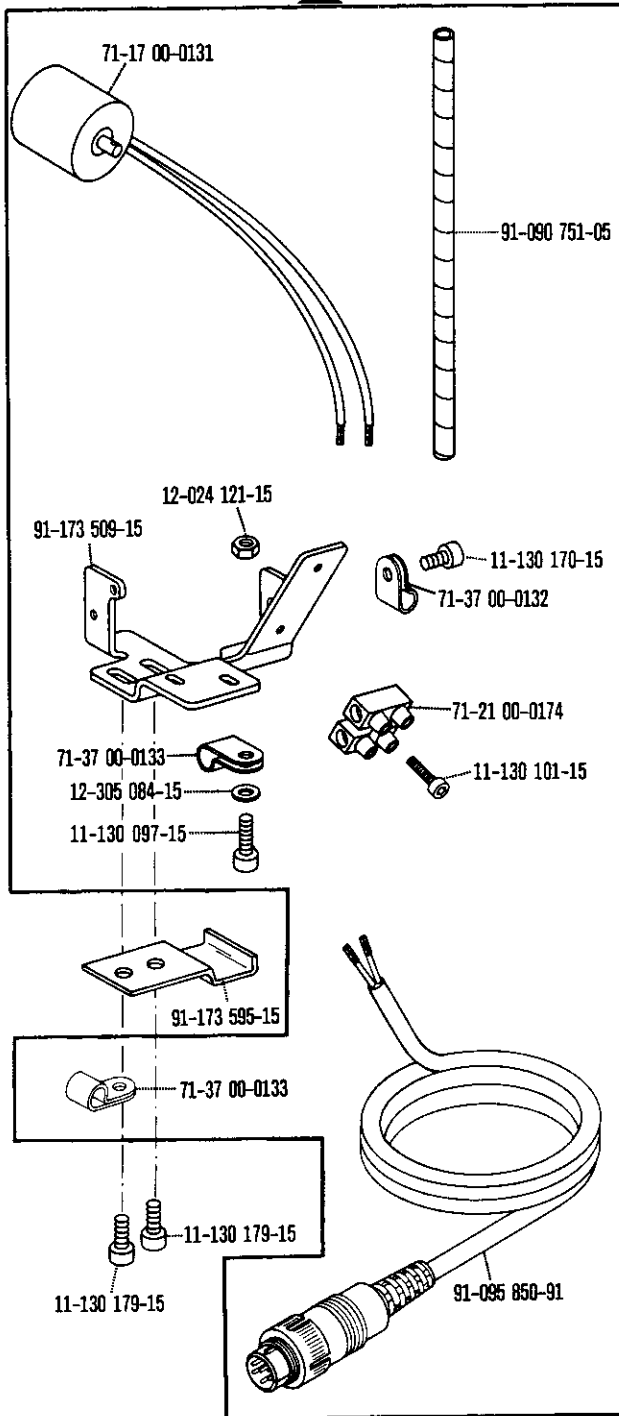

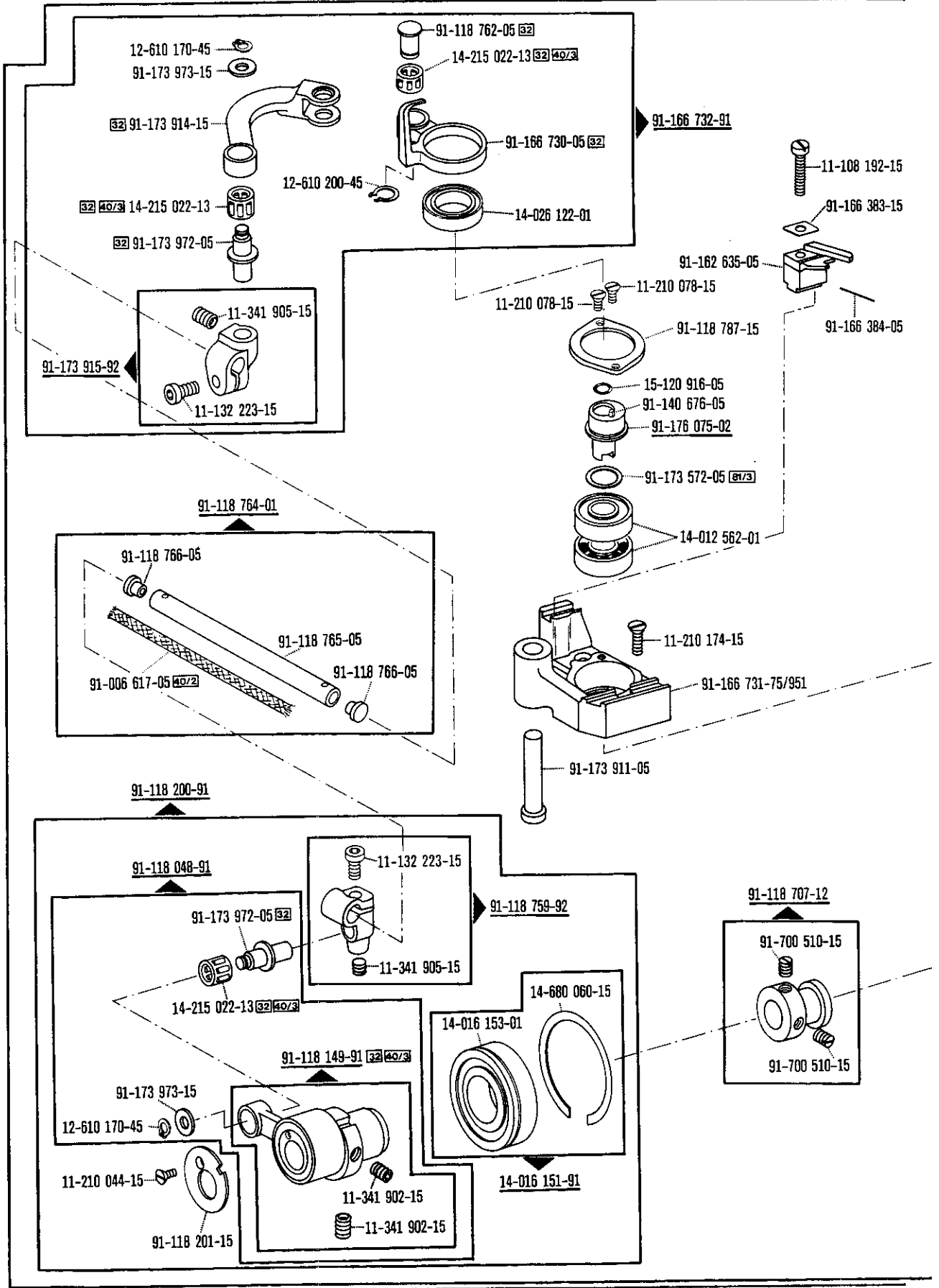

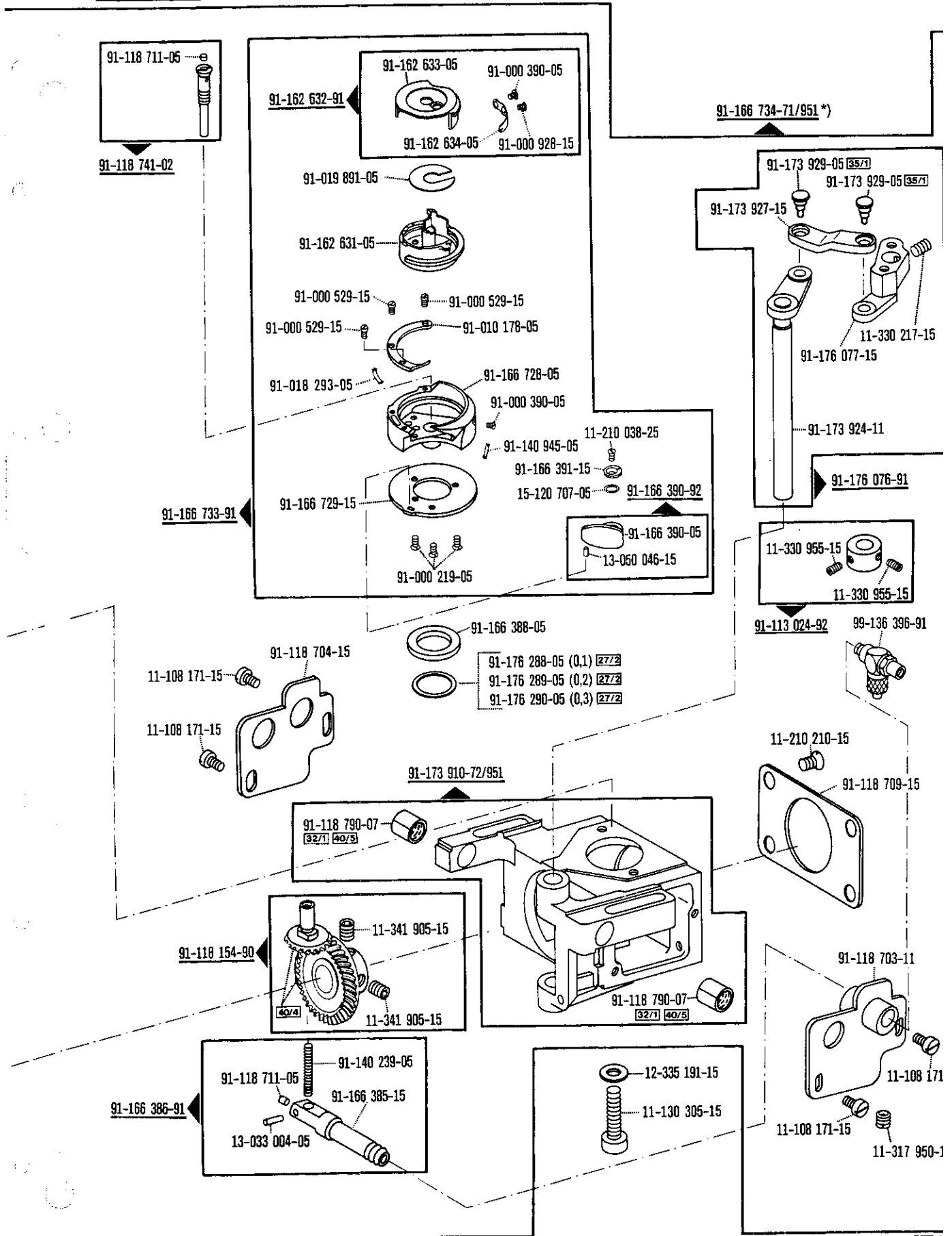

□ siehe Erläuterungen Register 0
see explanations in section 0

*) Gruppenteilnummer beinhaltet die Seiten 40, 41, 42, 43
Group part number ... applies to pages 40, 41, 42, 43

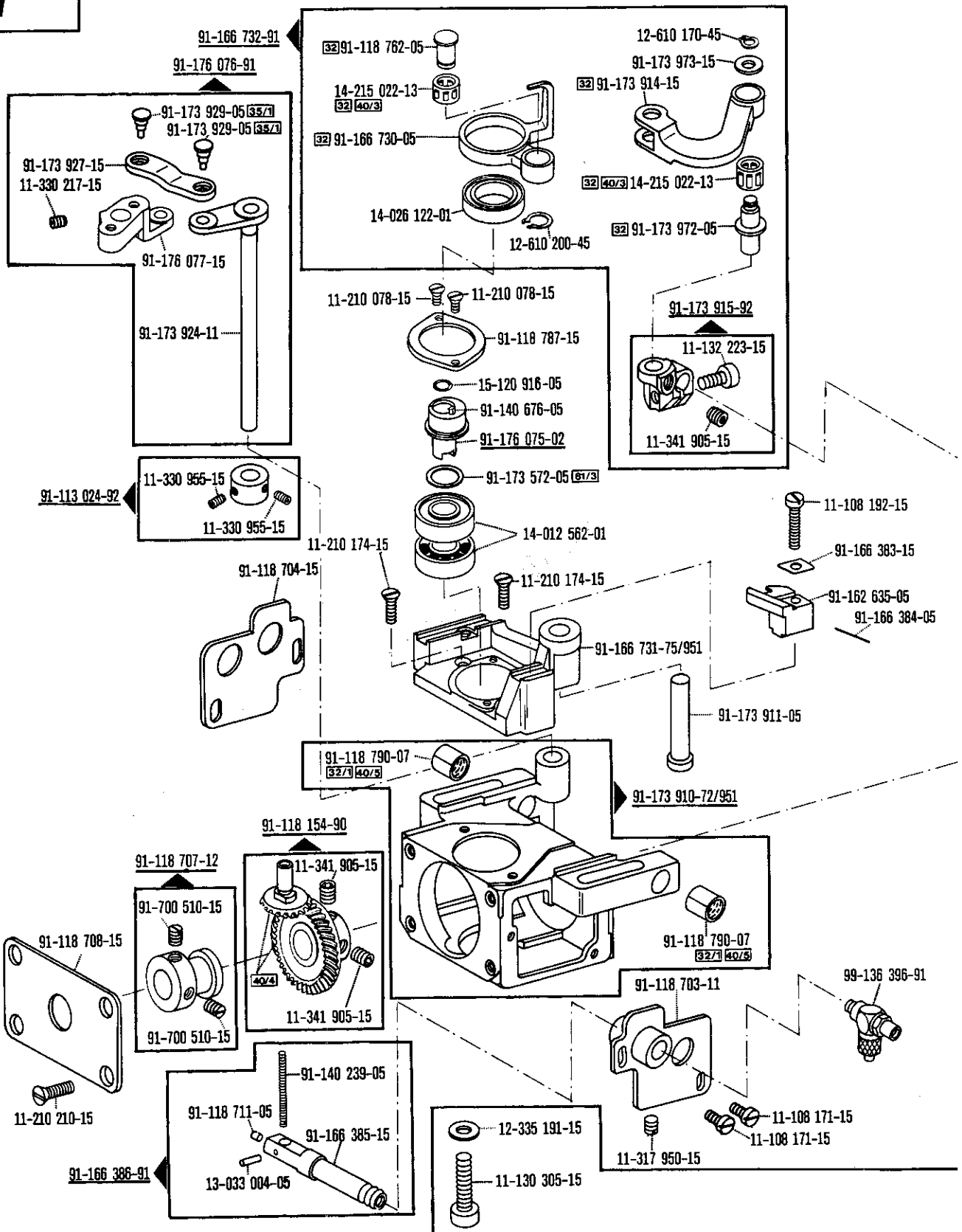

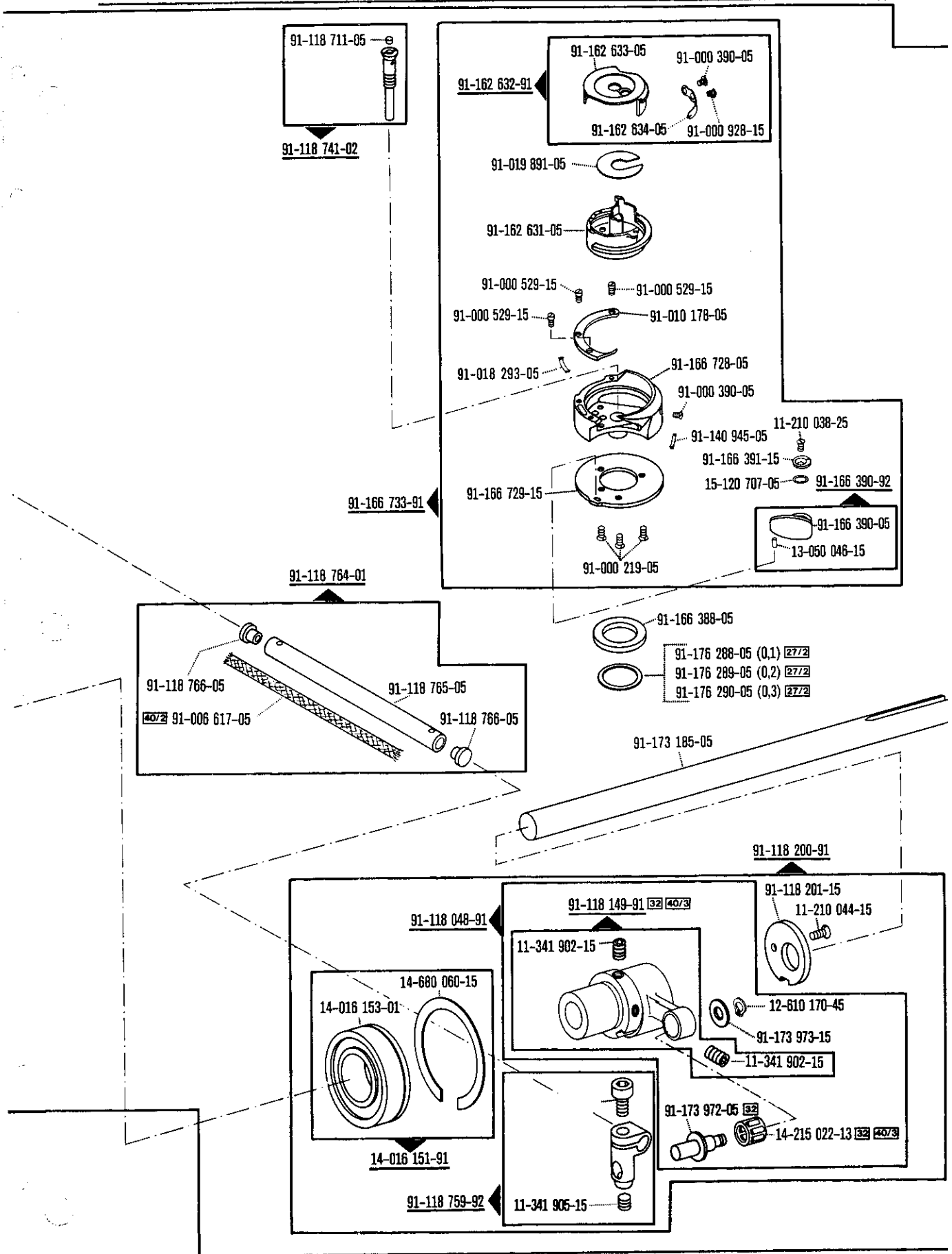

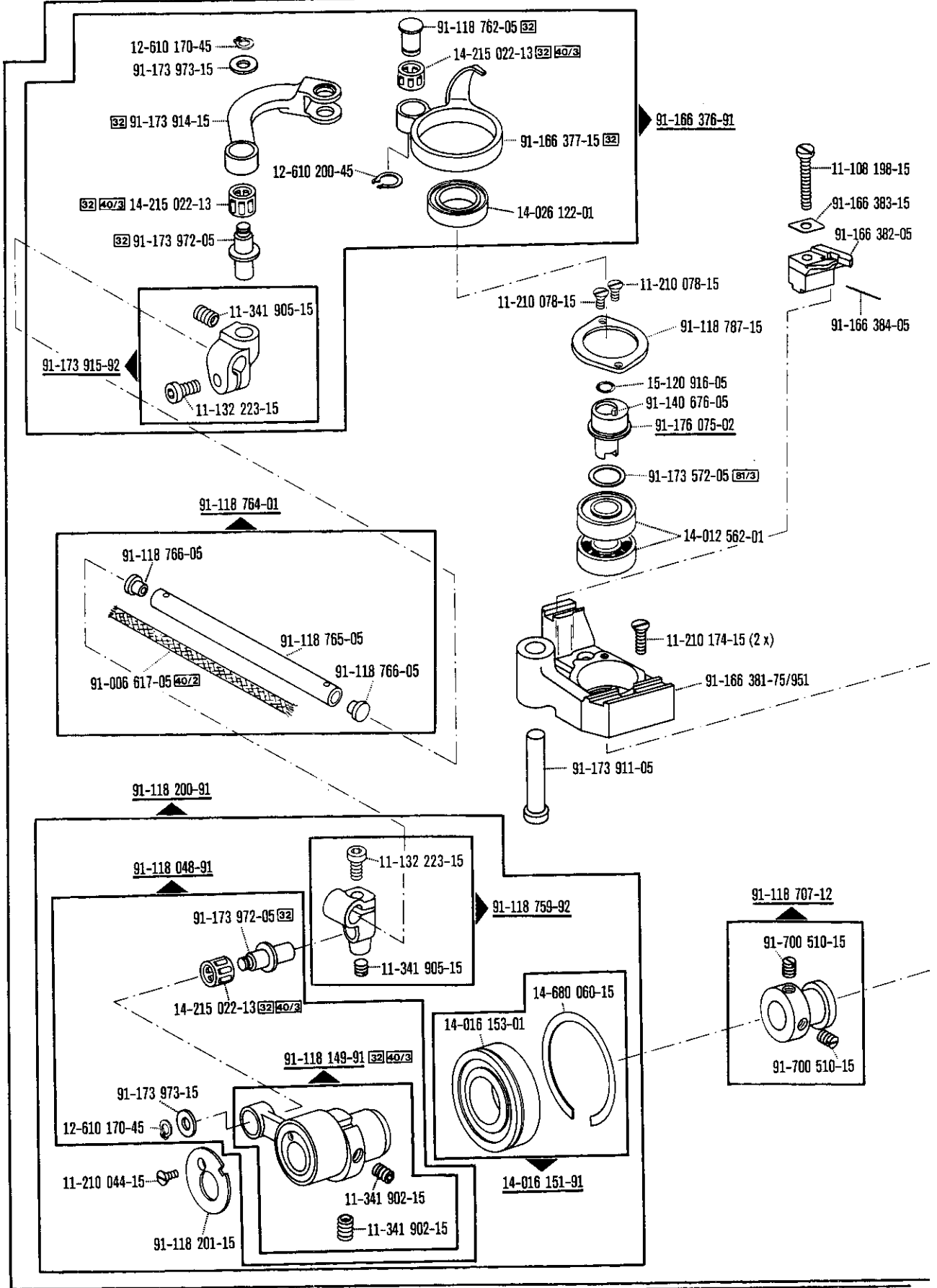

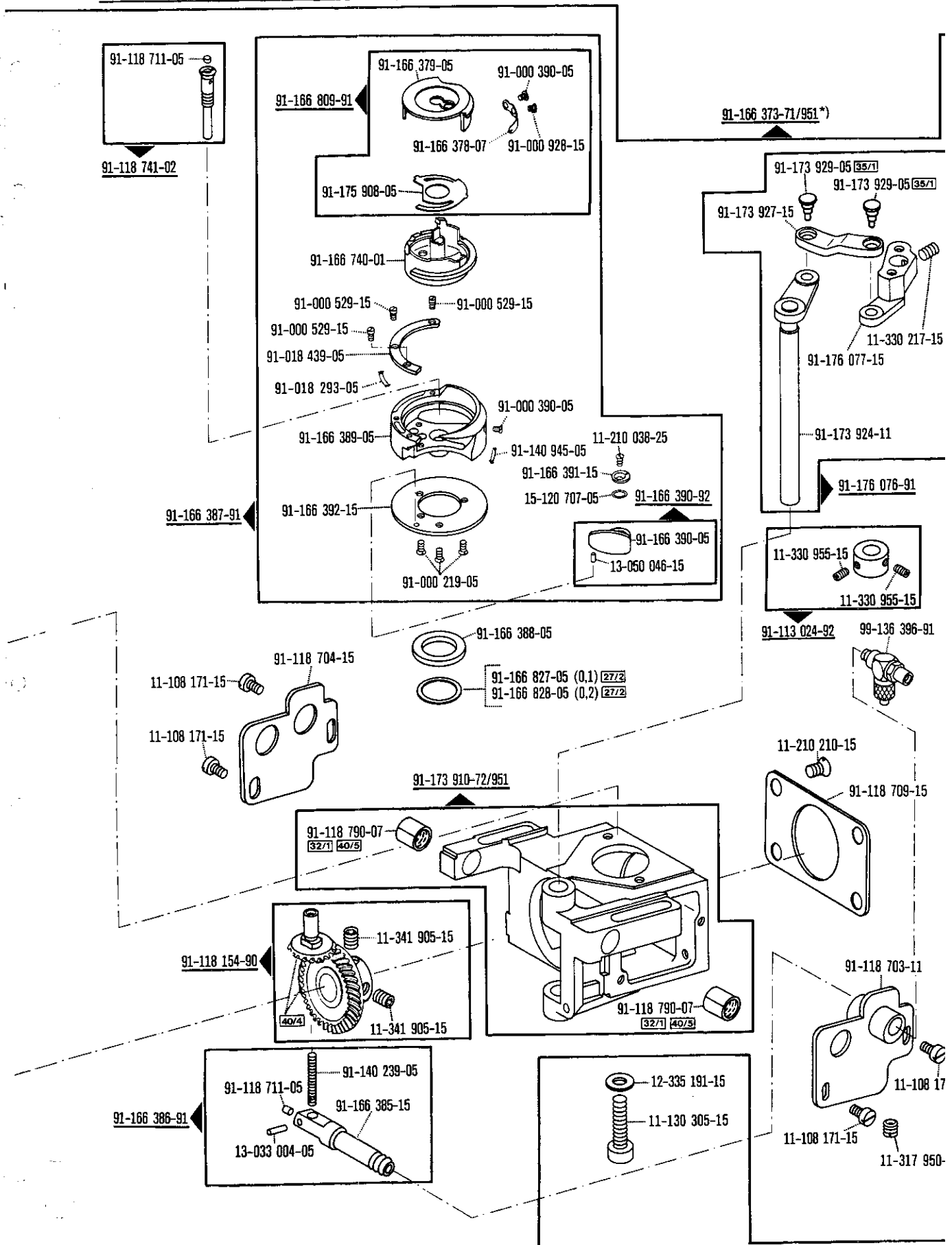

7

niveau trimmer
Coupe-fil
Cortahilos

-900/61 zur · pour
for · para Pfaff 1422-720/04

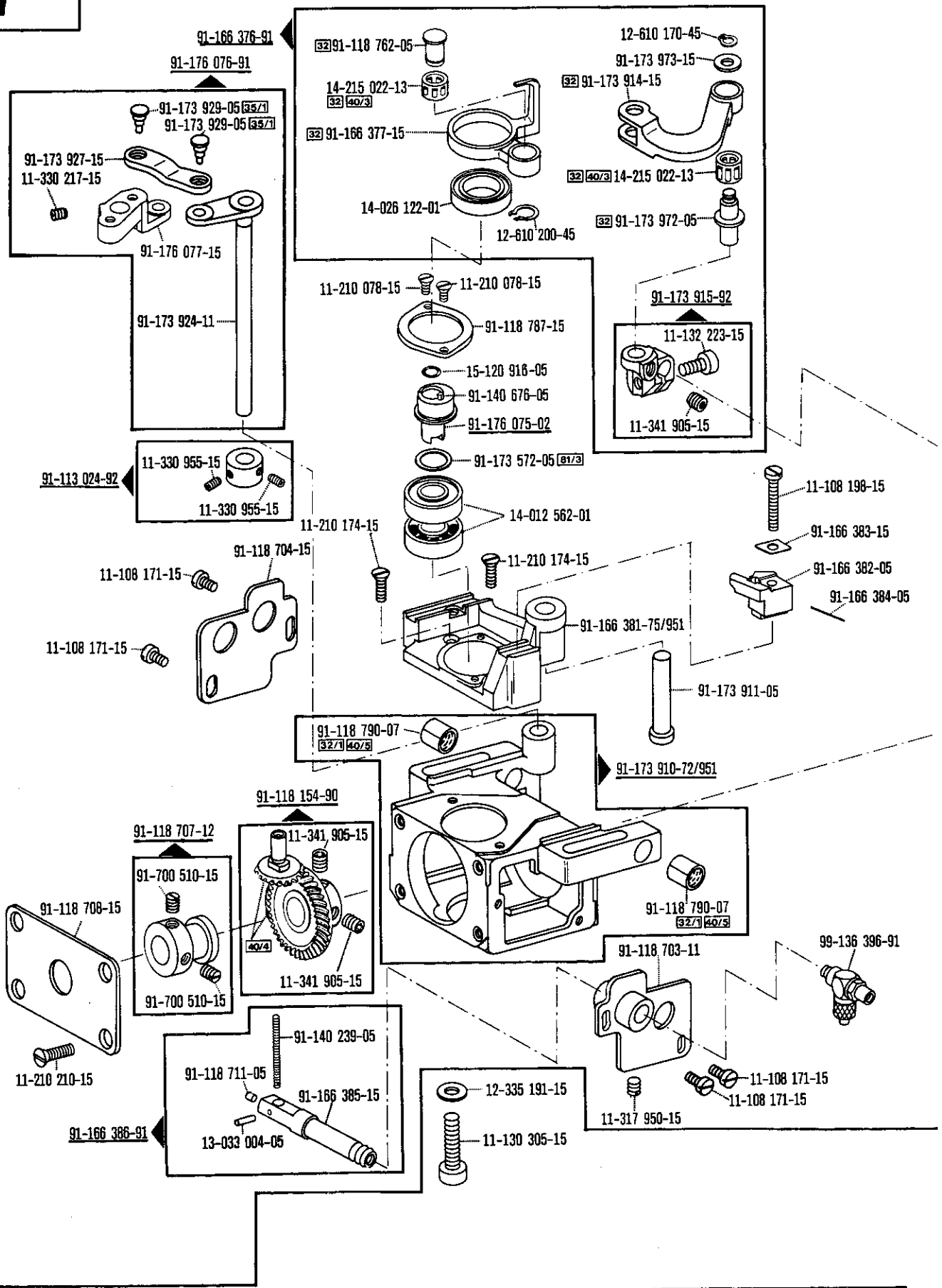

Thread trimmer
 Coupe-fil
 Cortahilos

-900/61 zur · pour
 for · para Pfaff 1422-720/04

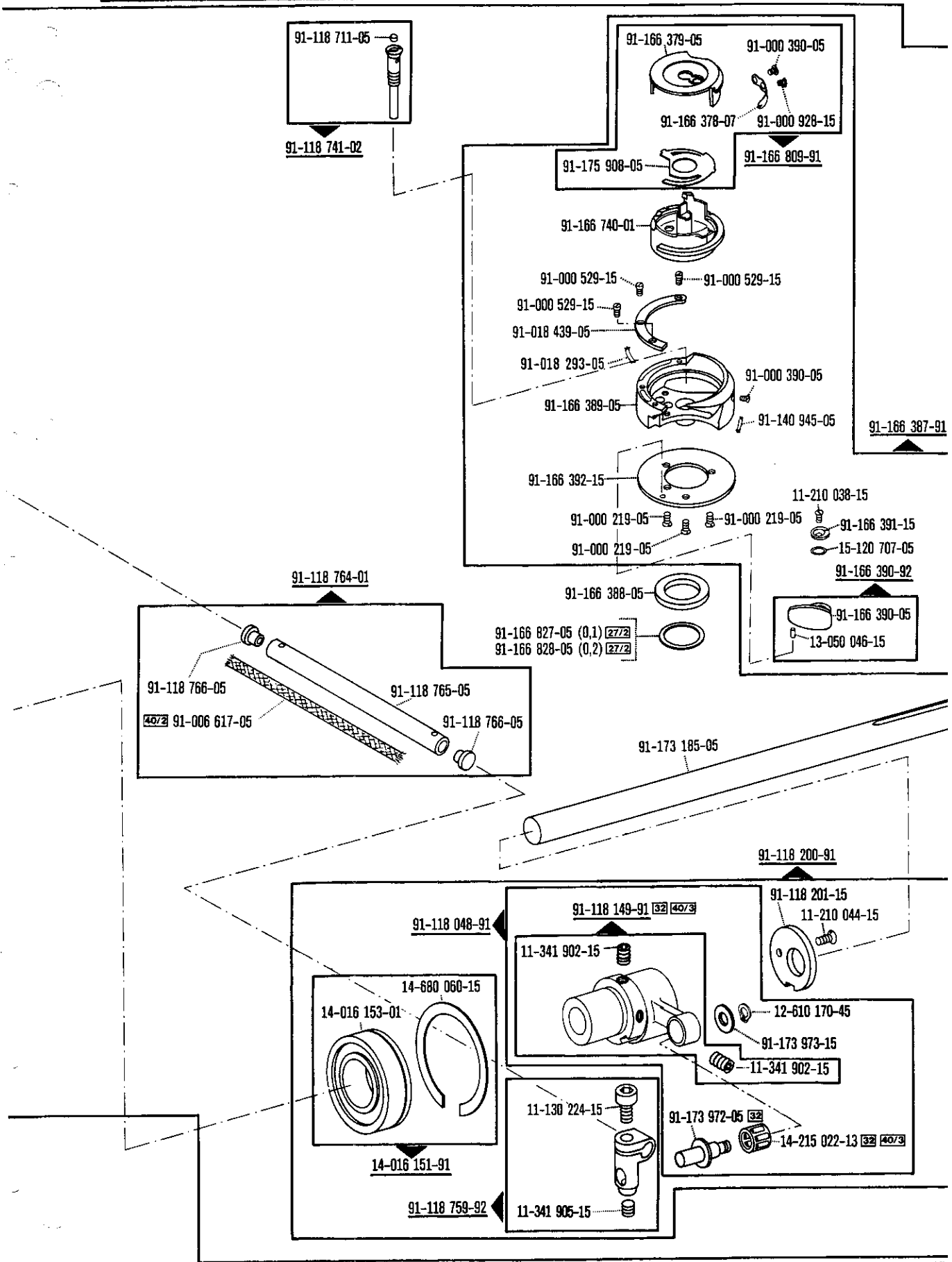

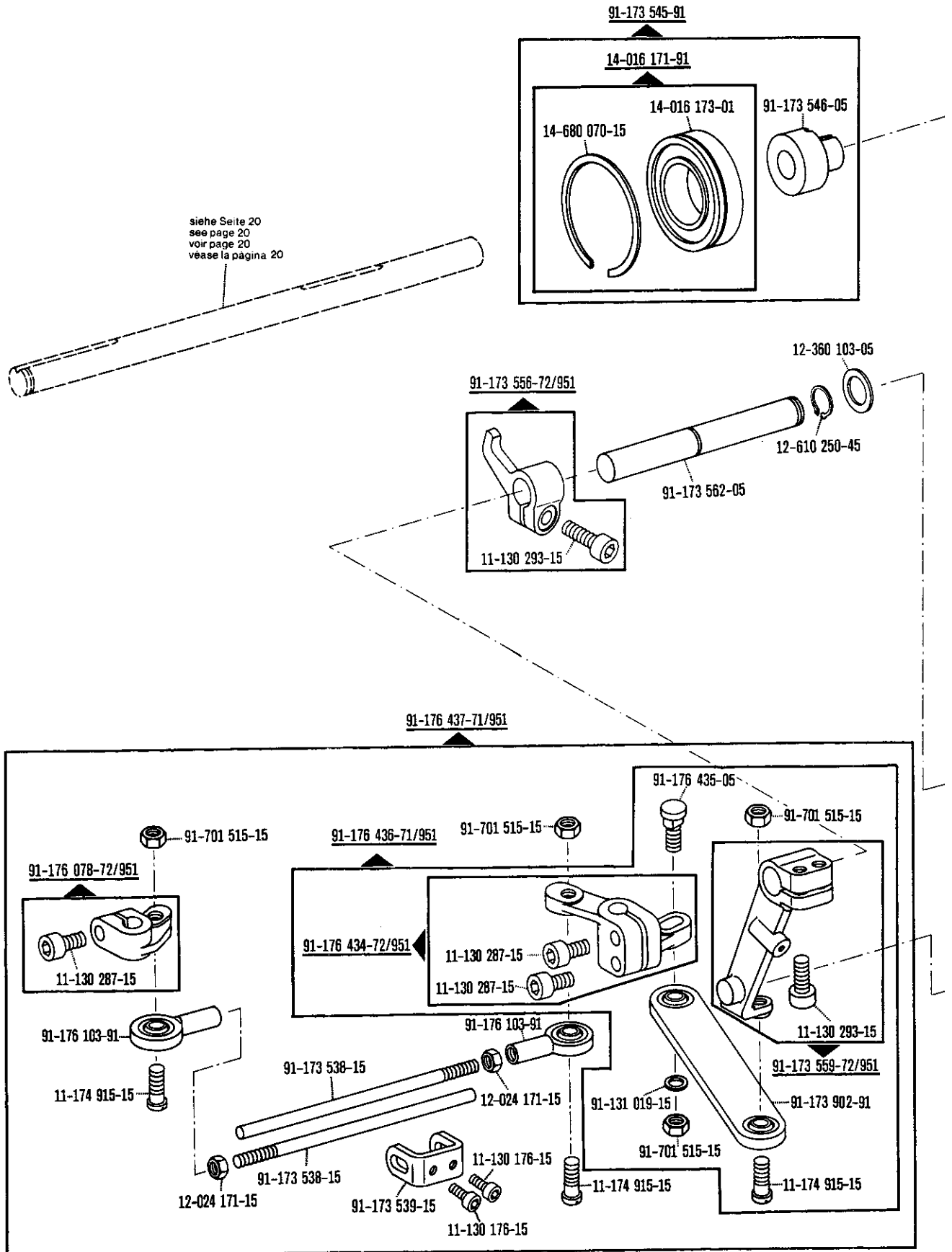

siehe Seite 20
see page 20
voir page 20
vease la página 20

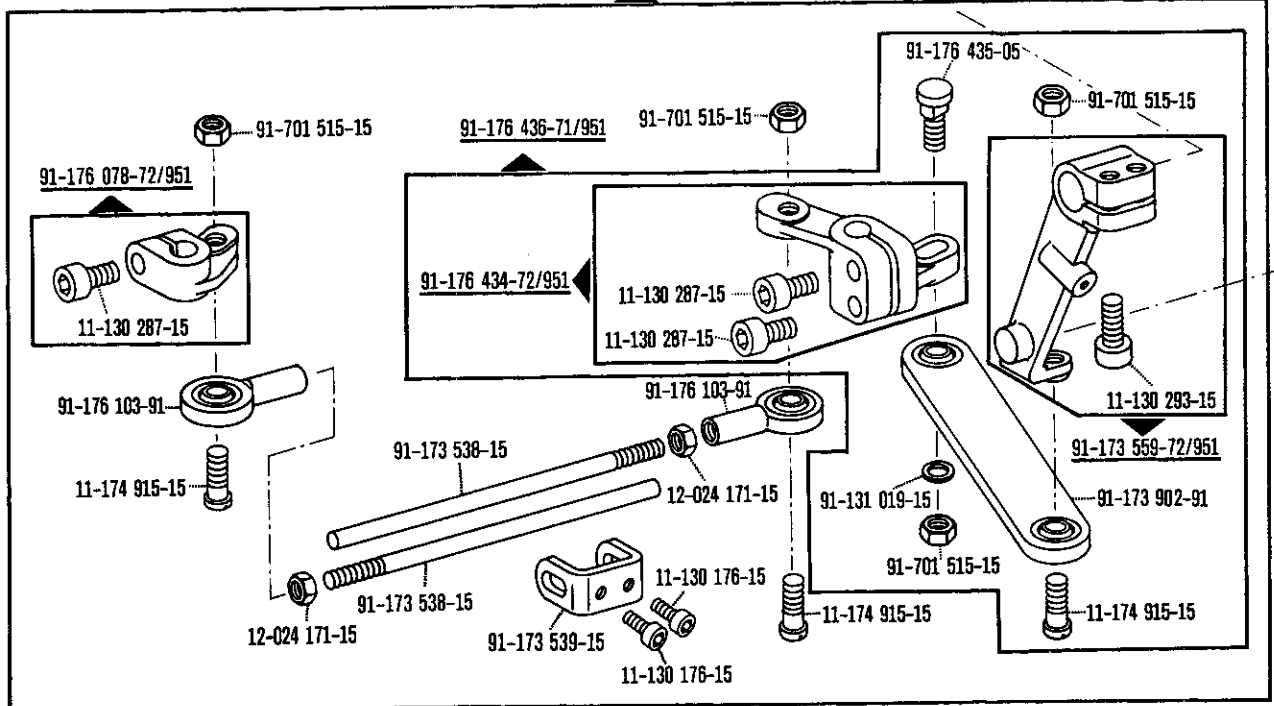
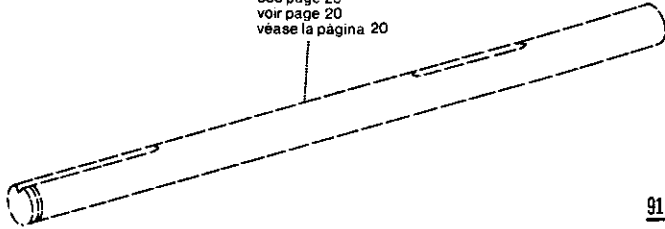

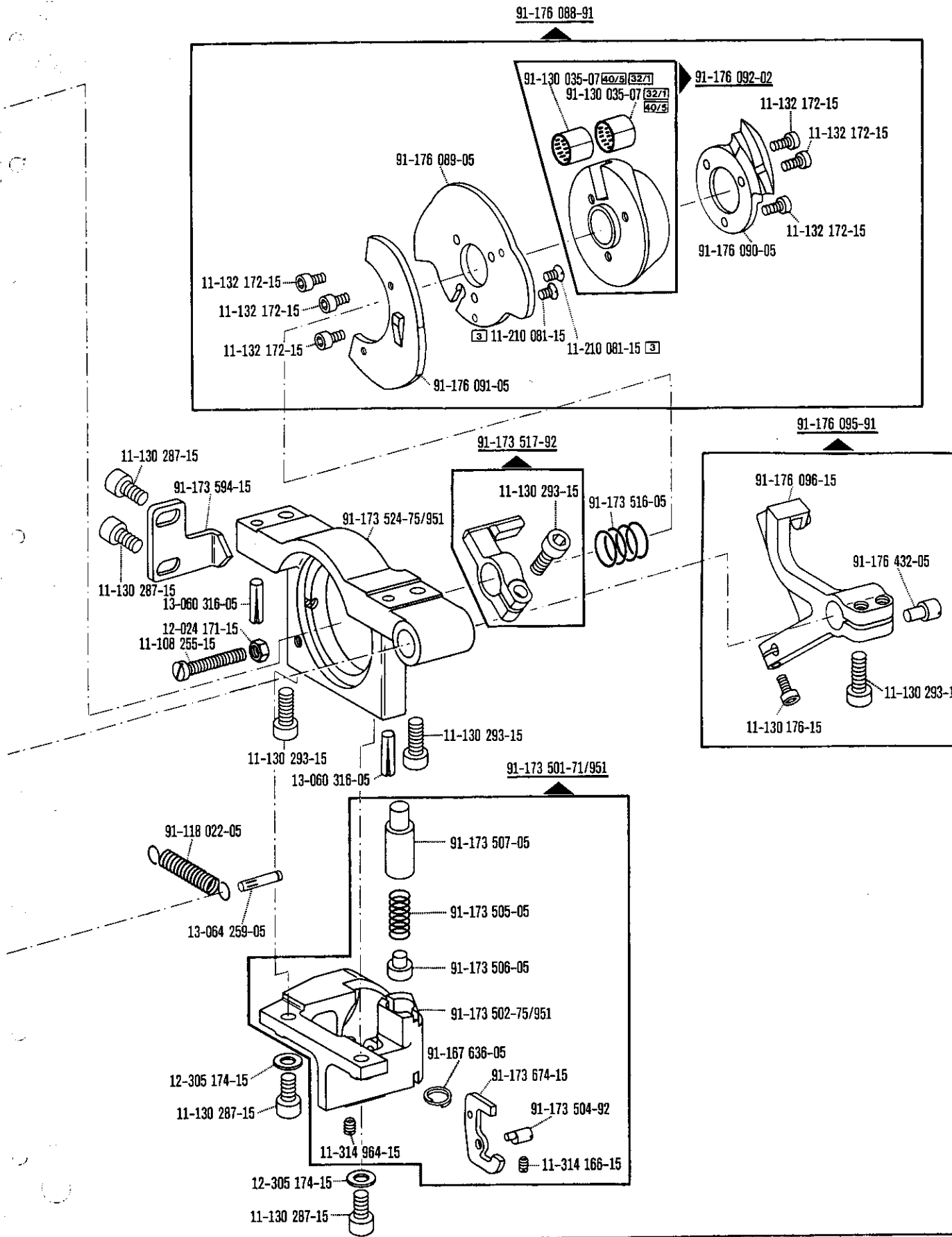

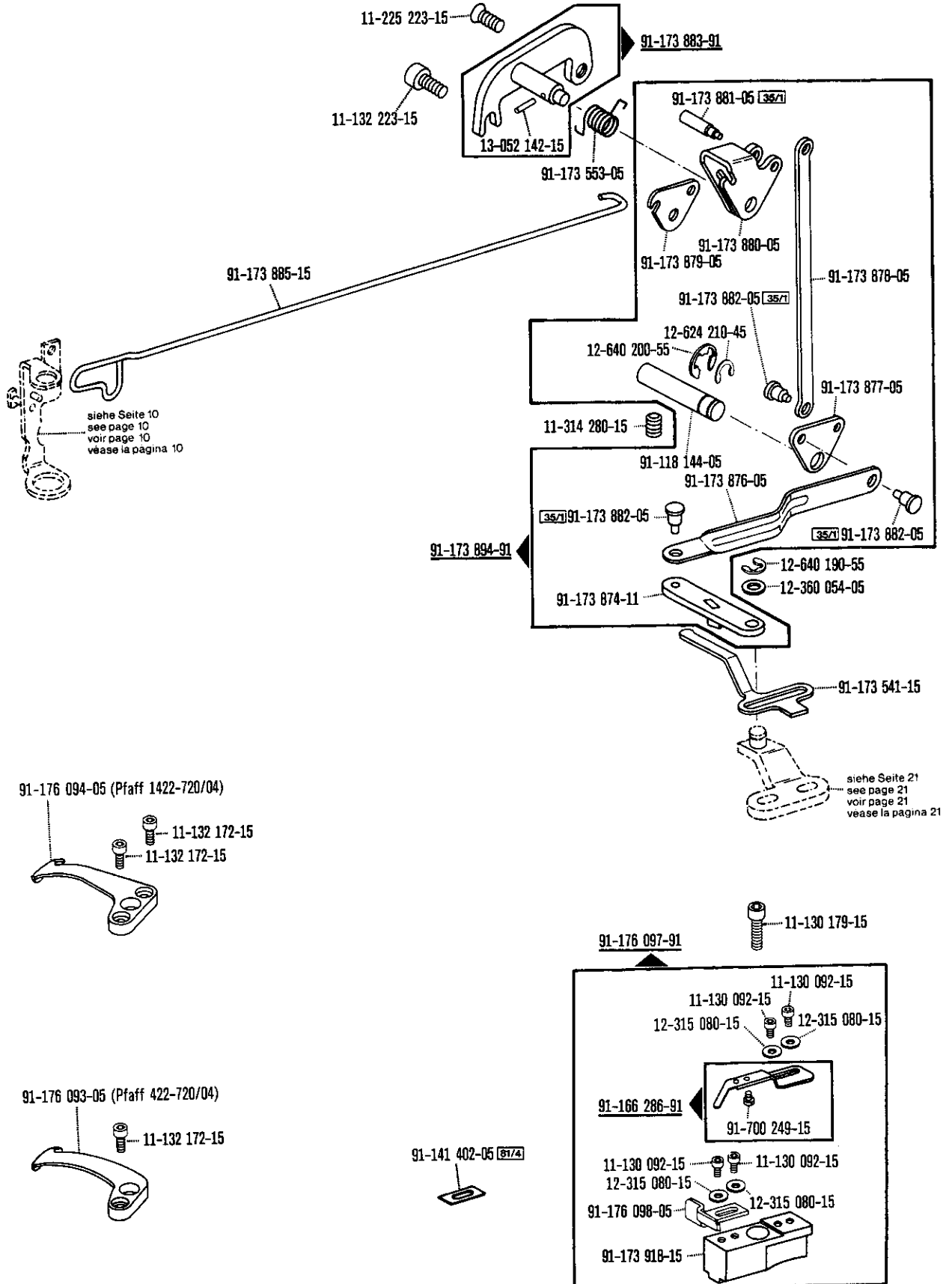

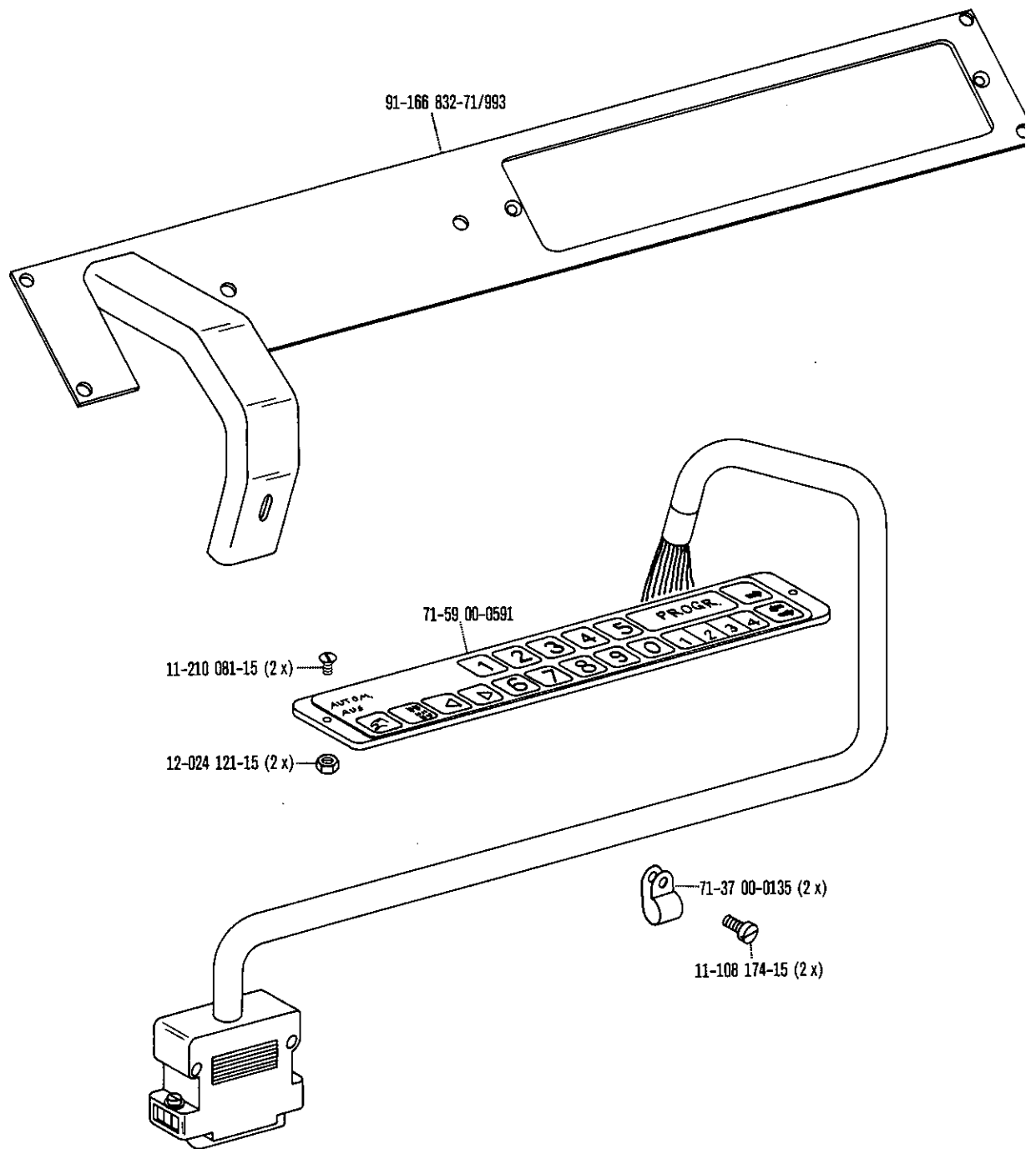

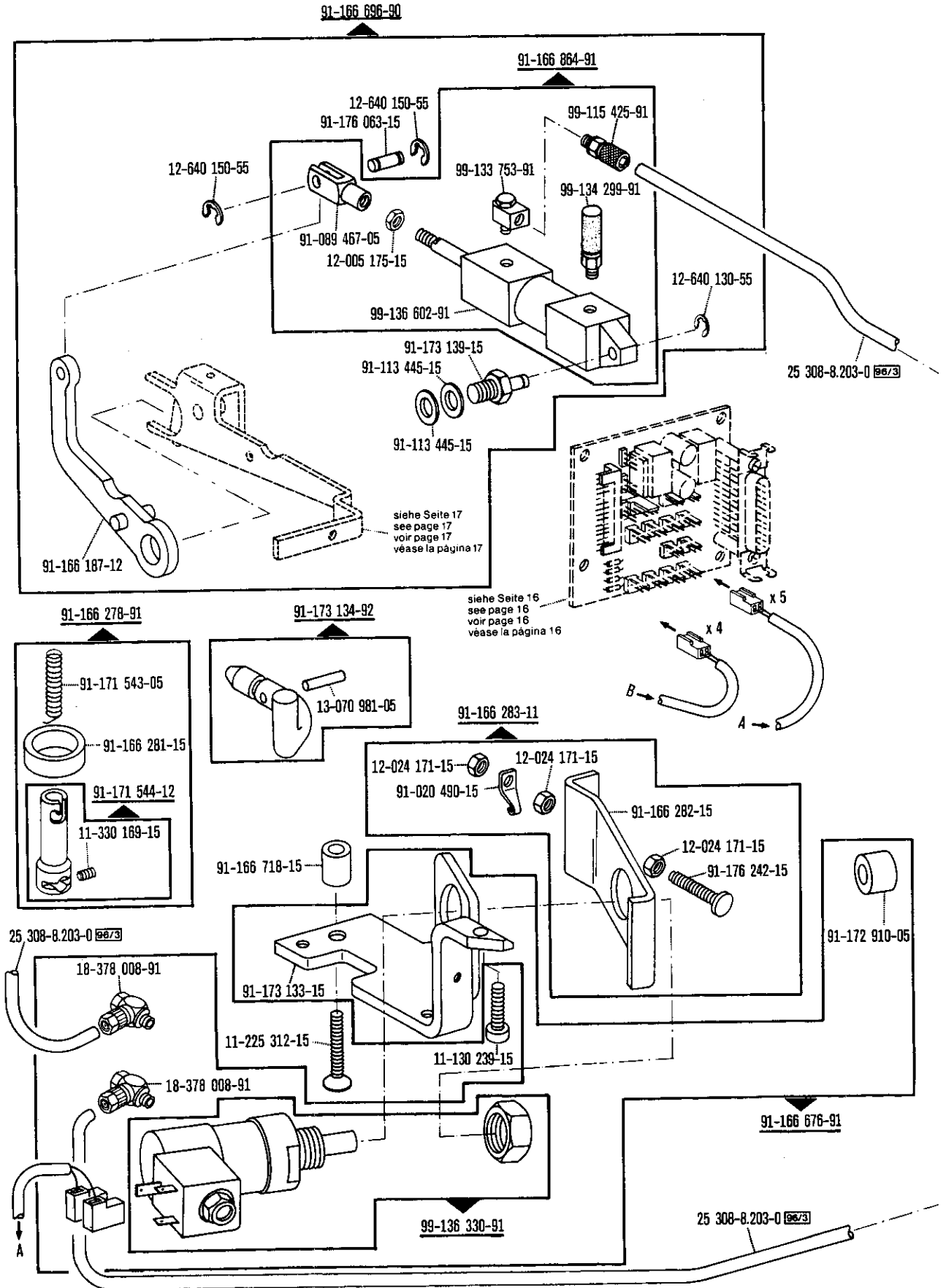

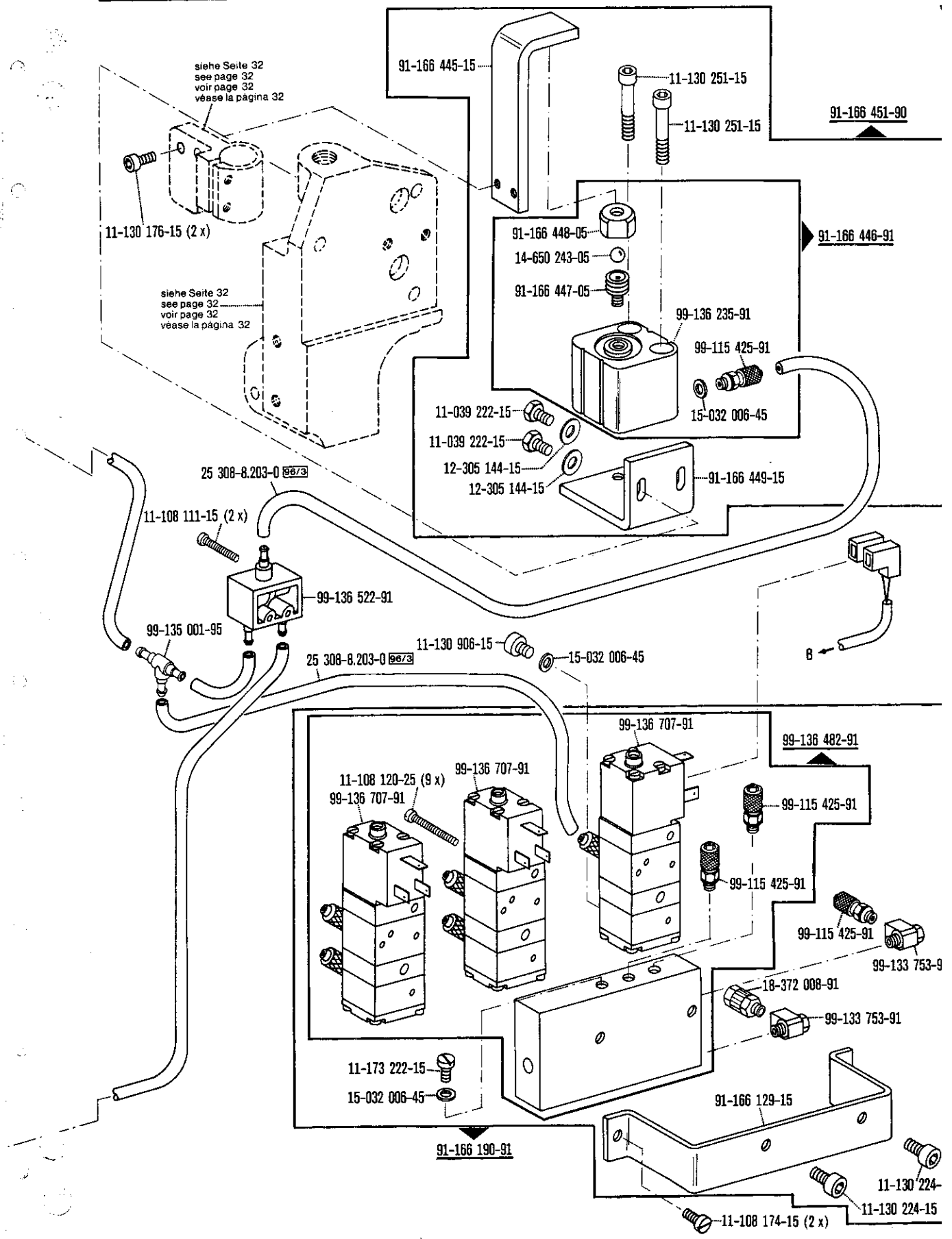

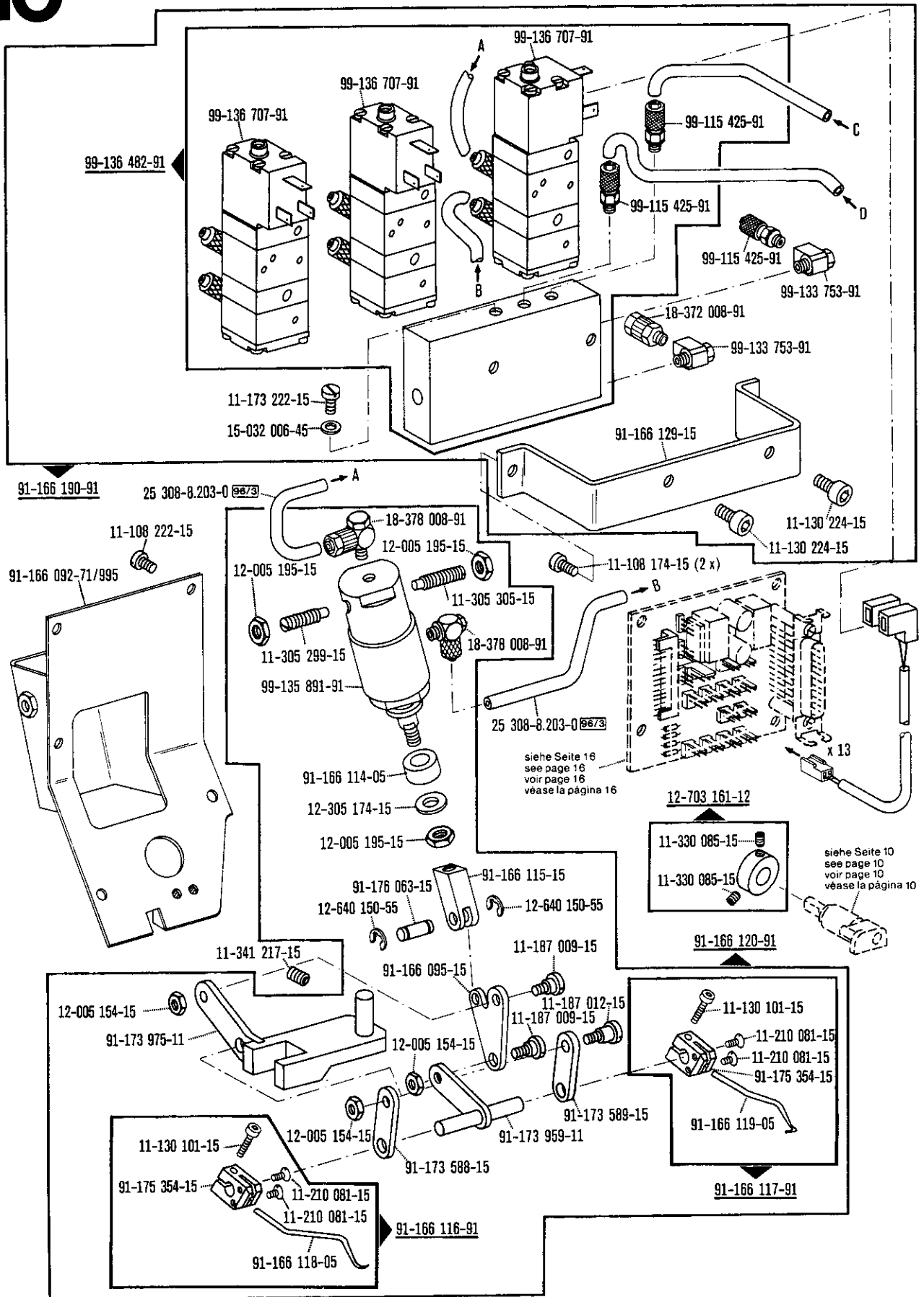

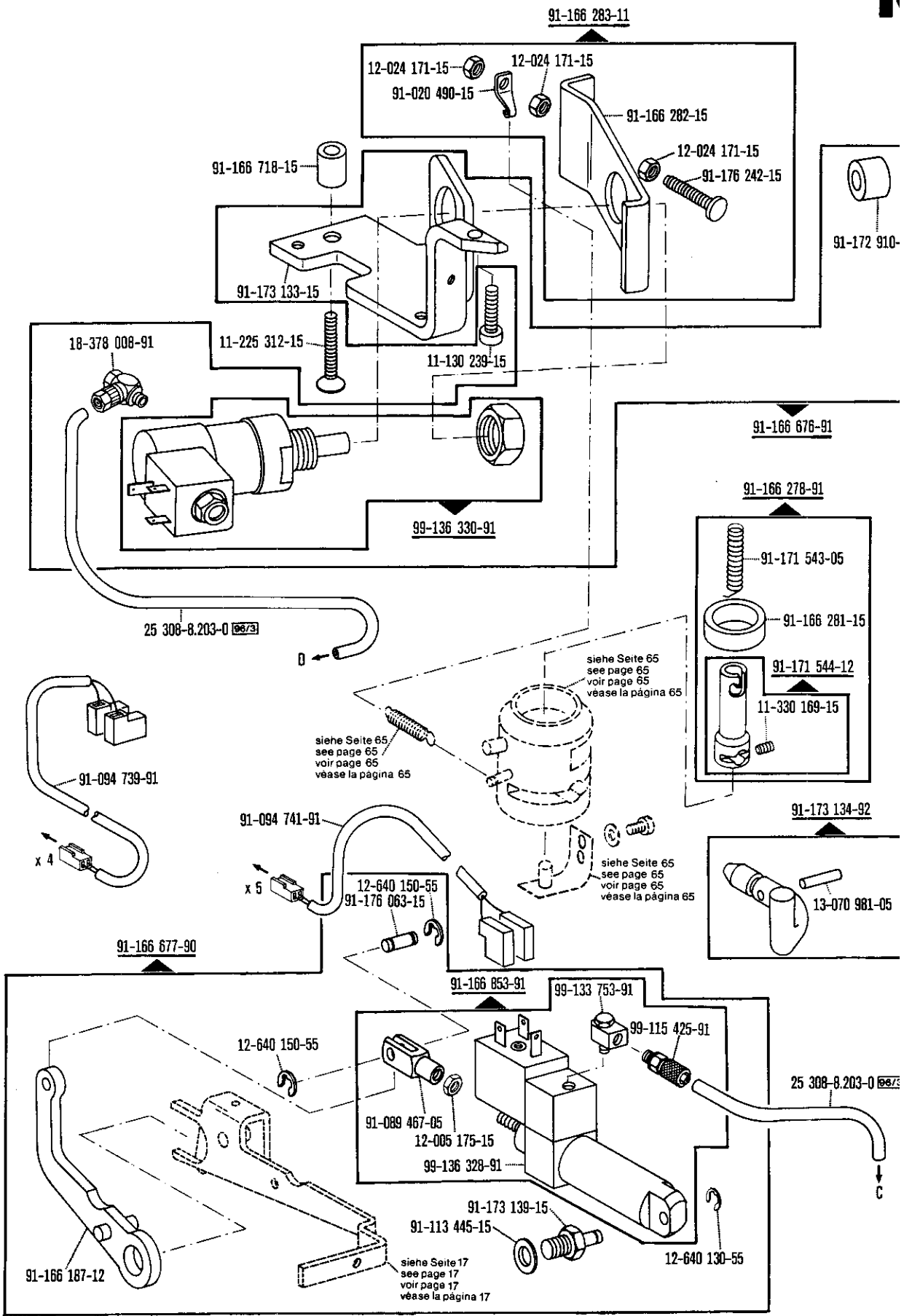

□ siehe Erläuterungen Register 0

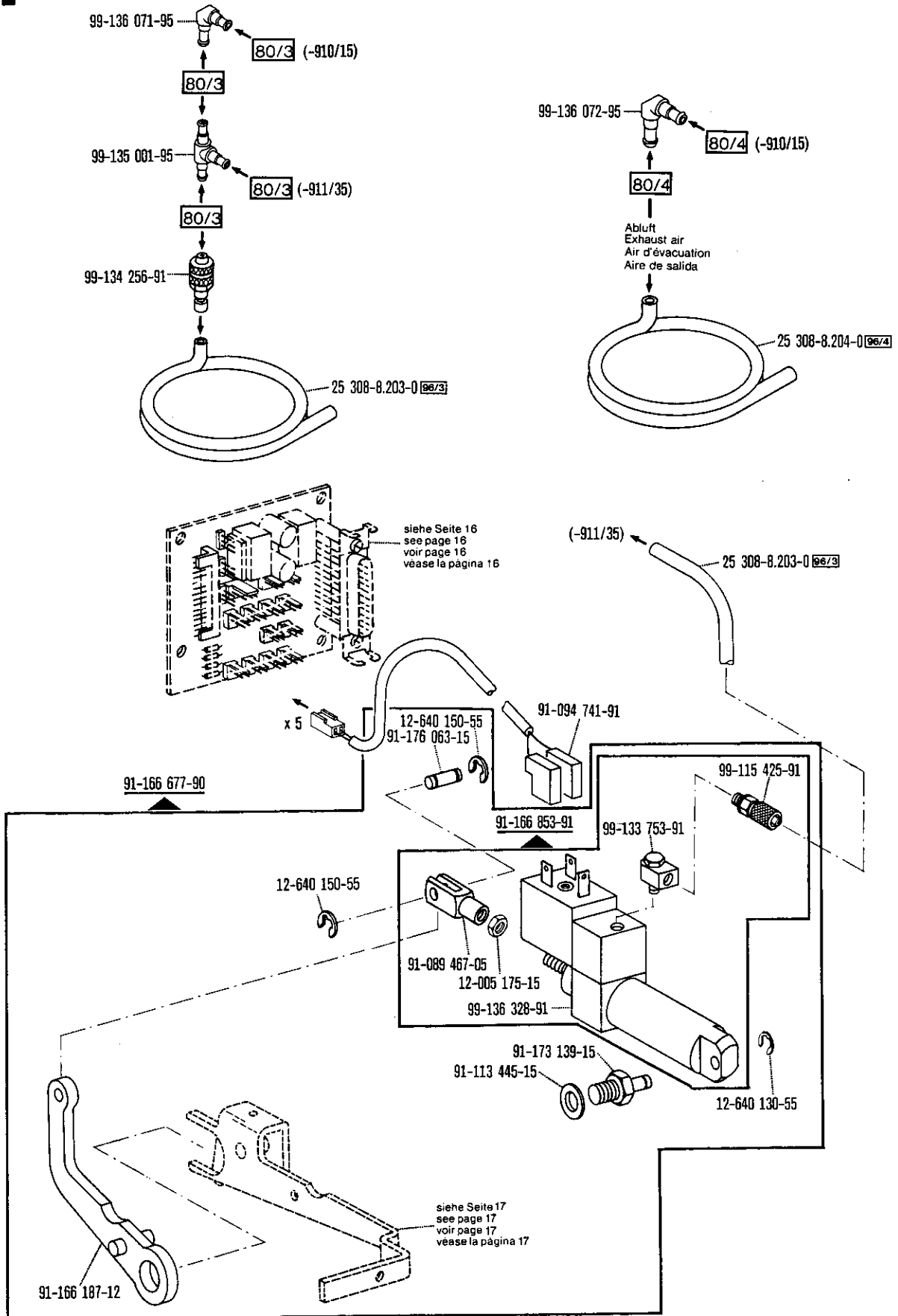

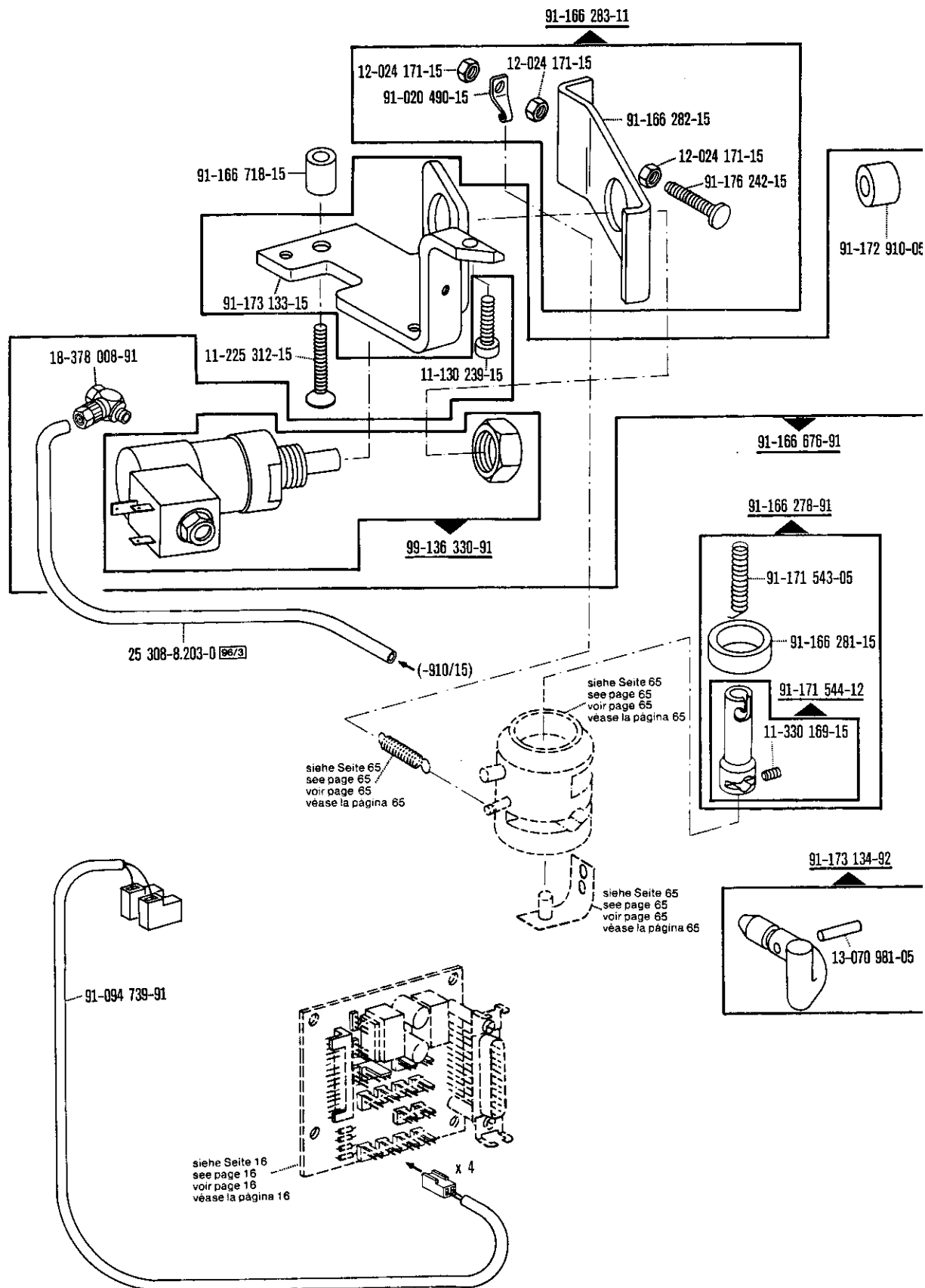

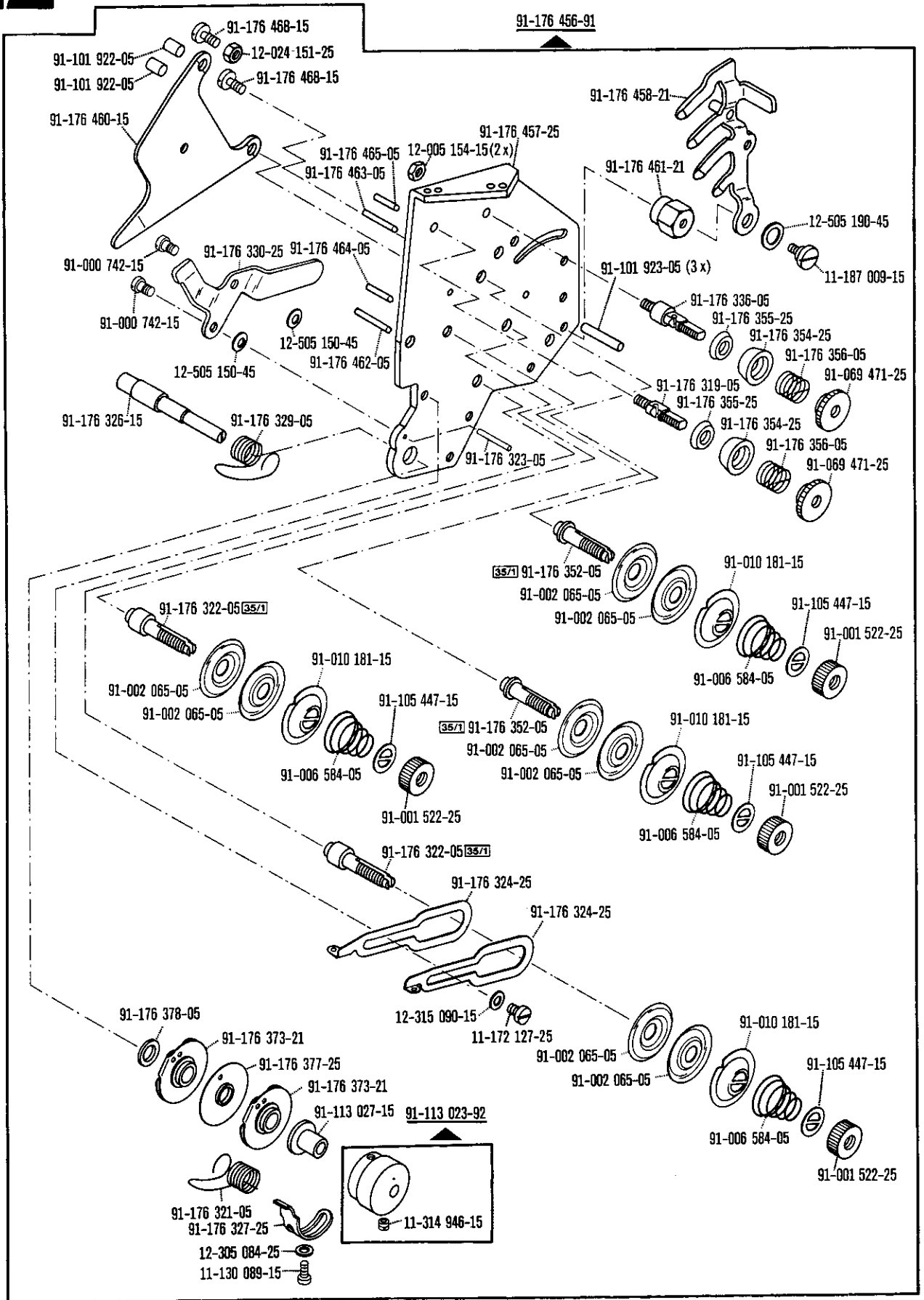

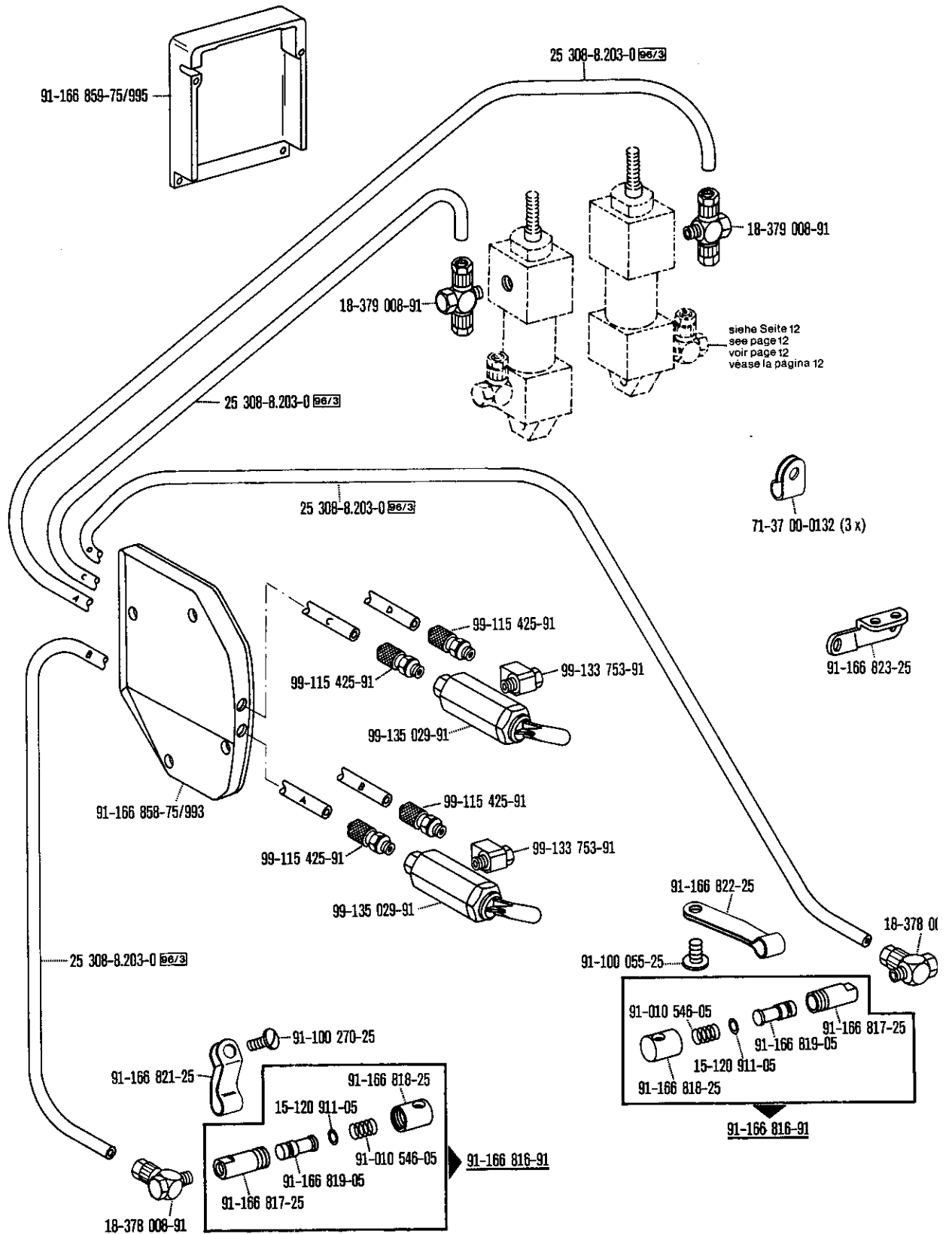

siehe Seite 12
 see page 12
 voir page 12
 véase la página 12

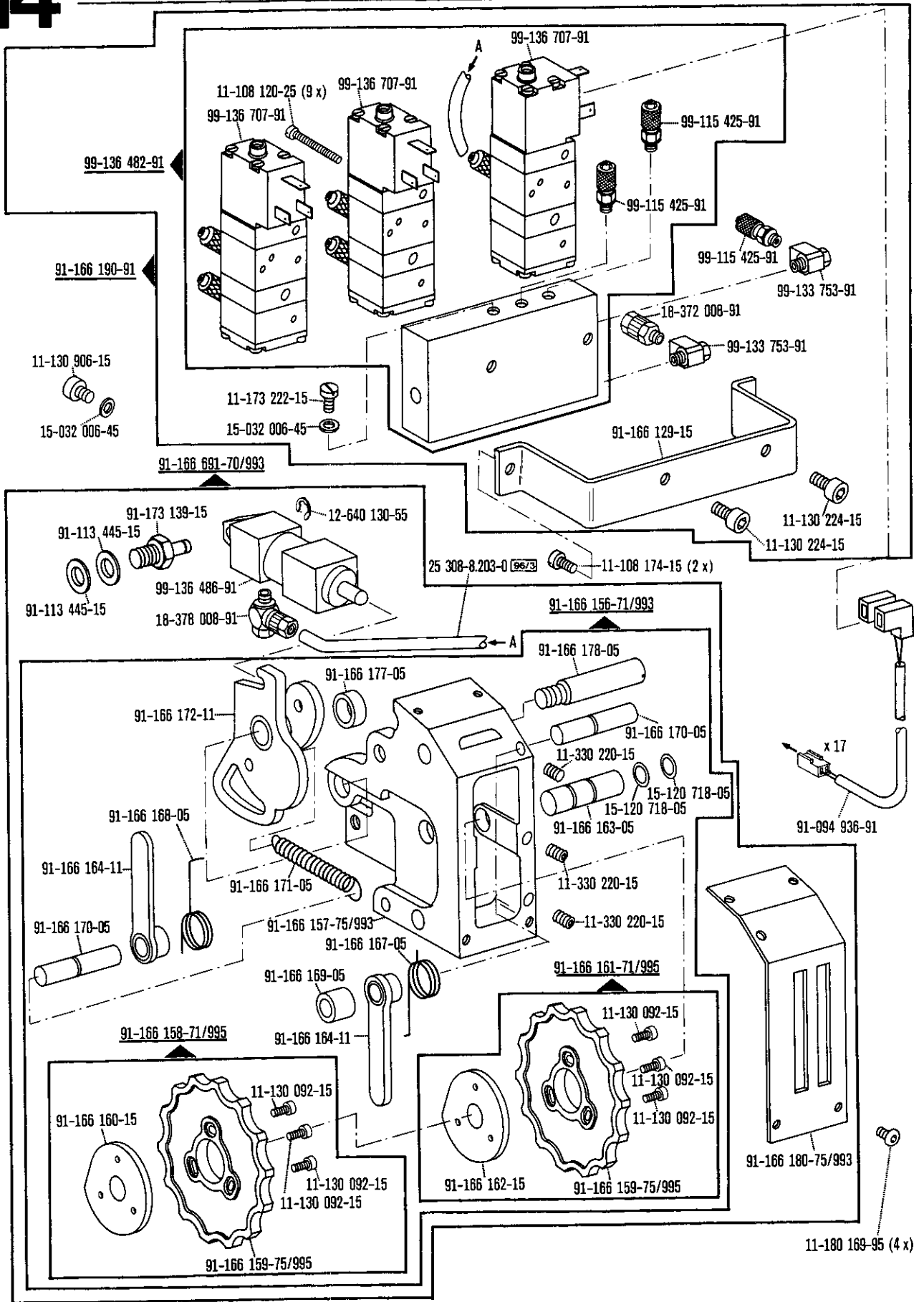

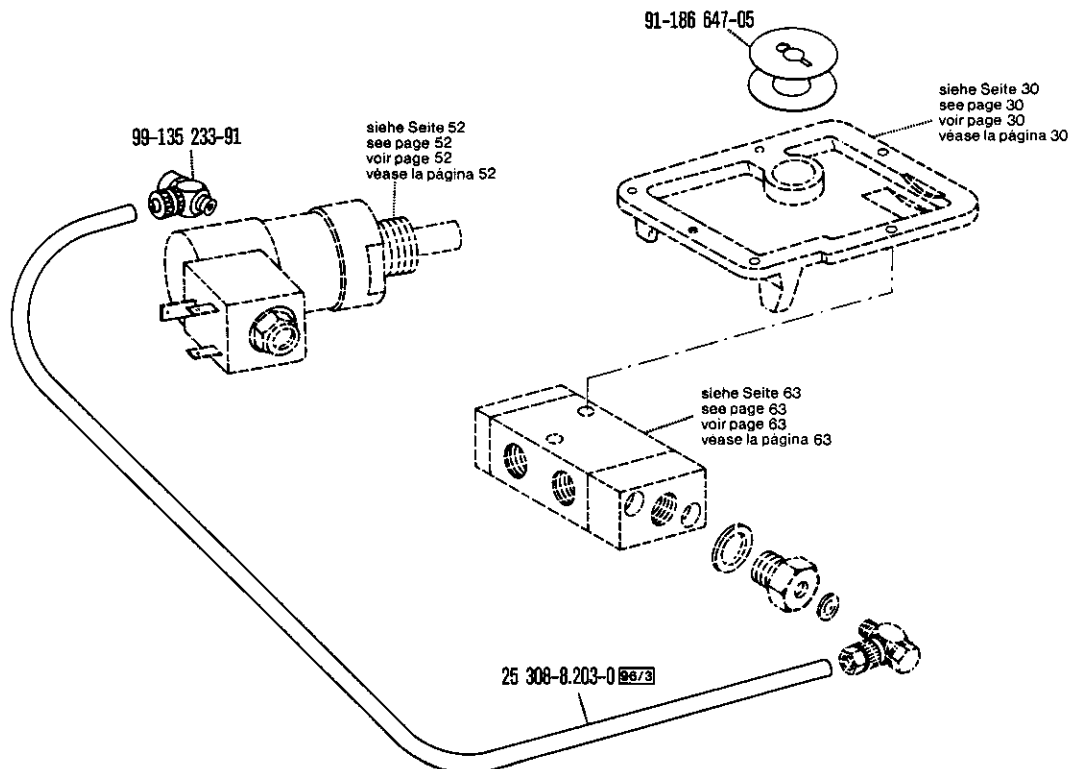
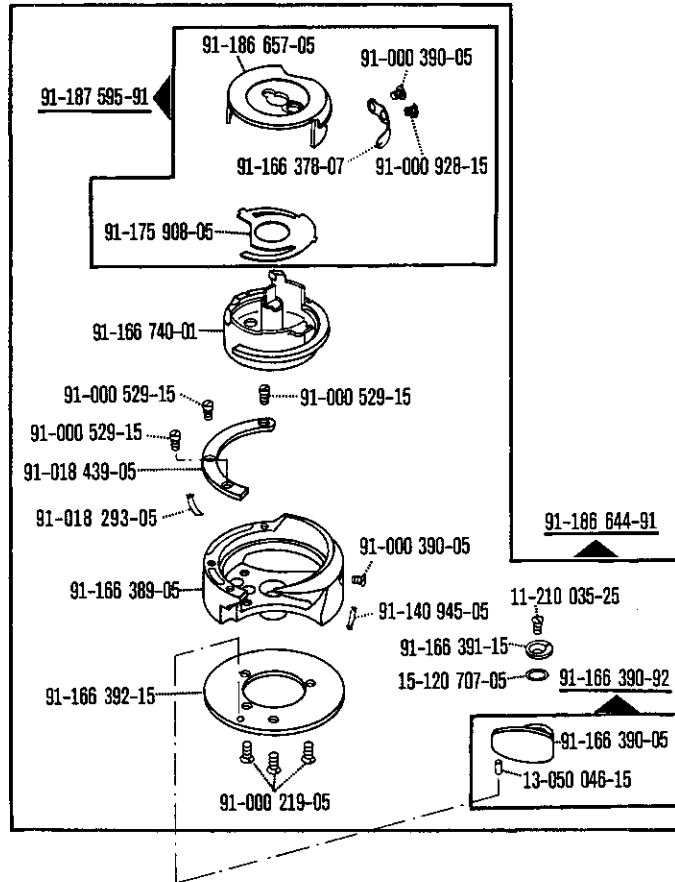

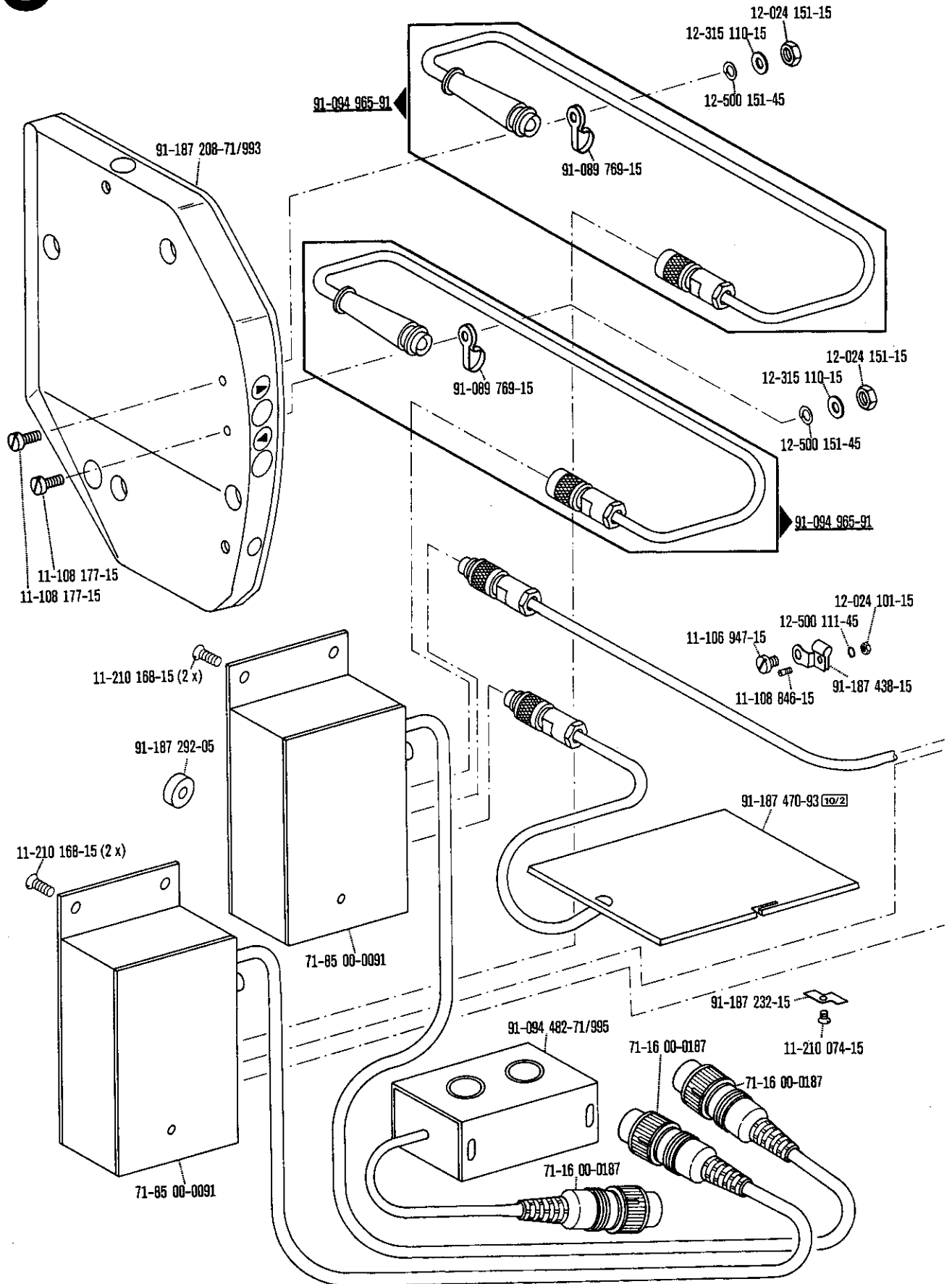

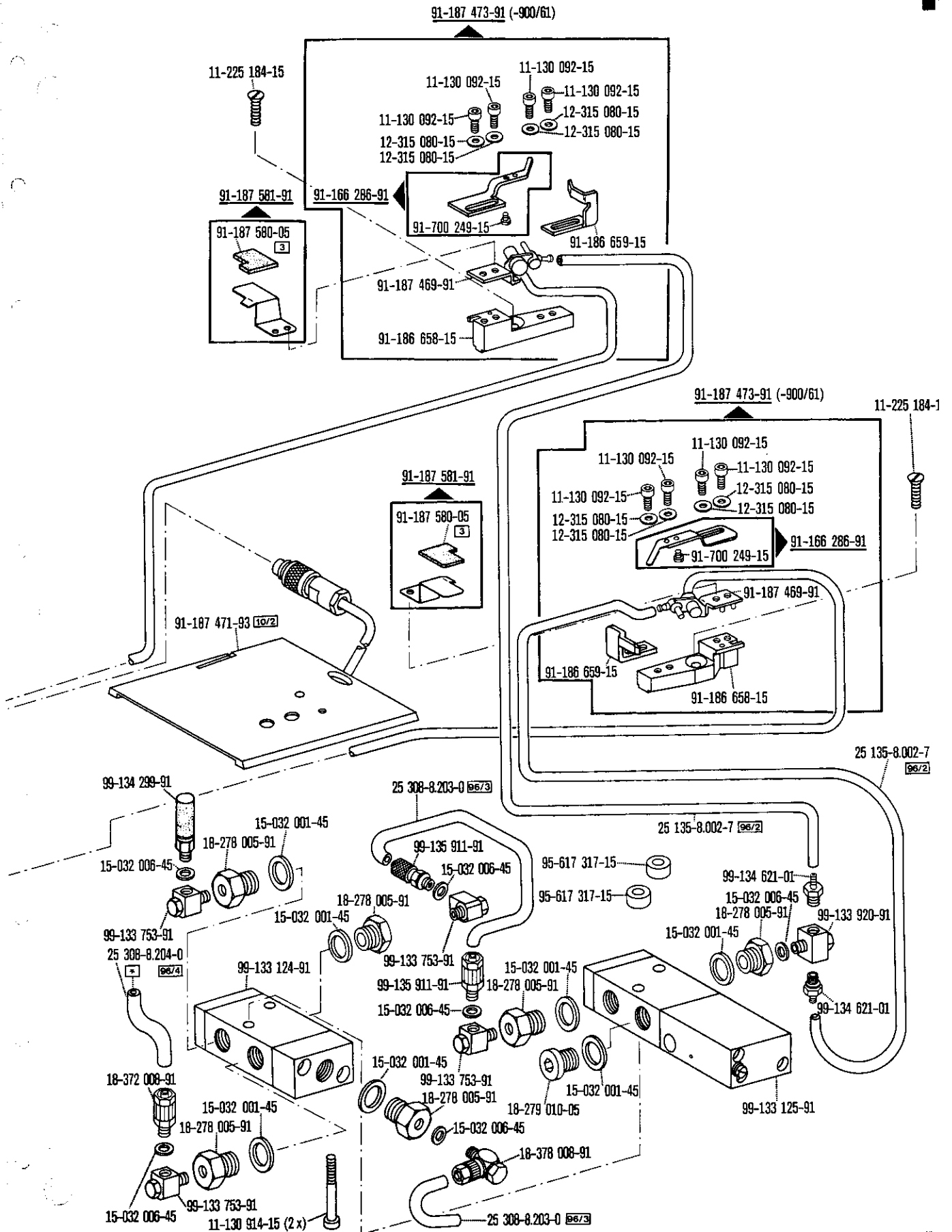

☐ siehe Erläuterungen Register O
 see explanations in section O

☒ Zur Wartungseinheit
 For conditioning unit

16

Operation panel
 Panneau de commande
 Panel de mandos

zur · pour
 for · para

Pfaff 422-720/04
 Pfaff 1422-720/04

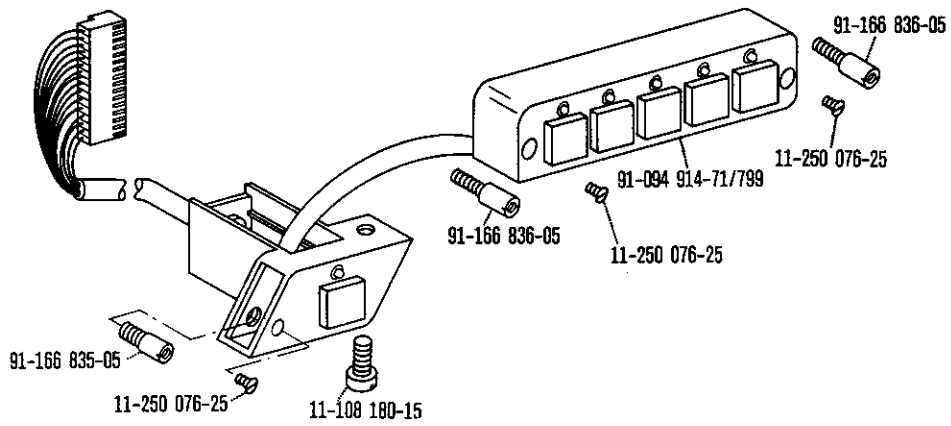

17

Bediengerät
 Control panel
 Console de commande
 Panel de mando

zur · pour
 for · para

Pfaff 422-720/04
 Pfaff 1422-720/04

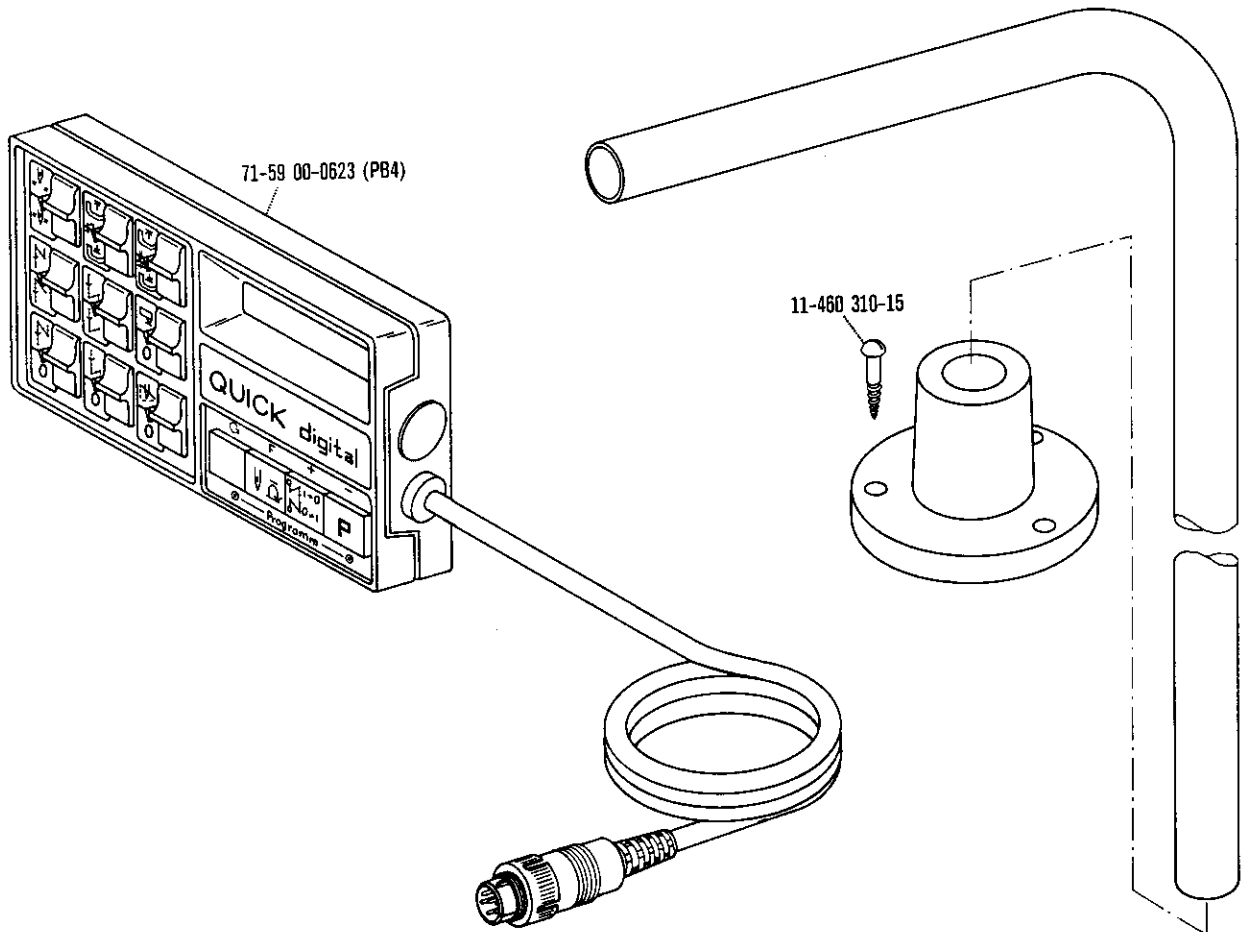

Accessory parts
Accessoires
Accesorios

zur · pour
 for · para

Pfaff 422-720/04
Pfaff 1422-720/04

System 134
 Système 134
 Sistema 134



System 134-35
 Système 134-35
 Sistema 134-35



System 134 H
 Système 134 H
 Sistema 134 H



91-018 480-05 (1422-720)



91-118 308-05 (Pfaff 422-720)



97-30 118-345

91-029 033-45

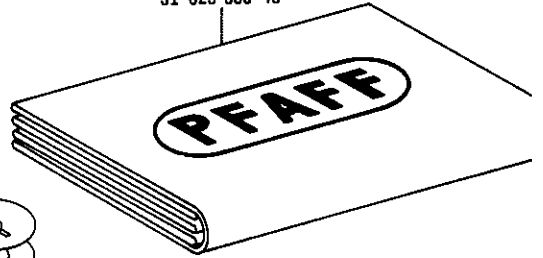

91-186 647-05
 (1422-720/04;
 -926/04)



91-021 123-05

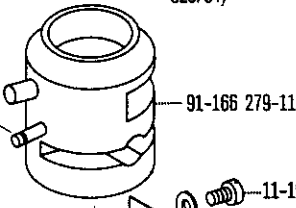

91-166 279-11

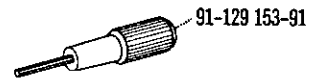

91-129 153-91

91-029 946-91



91-129 139-01
 leer
 empty
 vide
 vacia

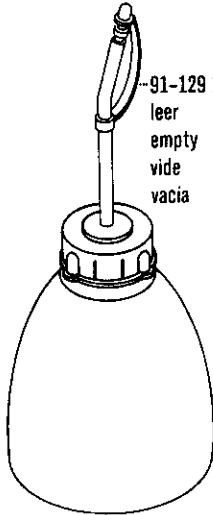

11-108 171-15

12-315 110-15

91-166 339-91

91-029 007-91

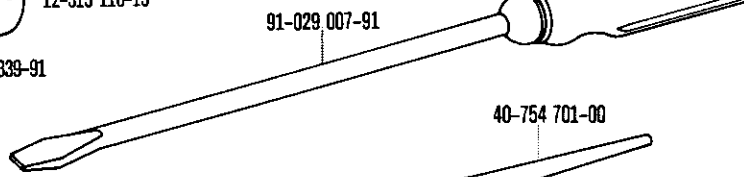

40-754 701-00

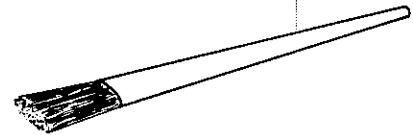

97-30 189-655 (-900/..)

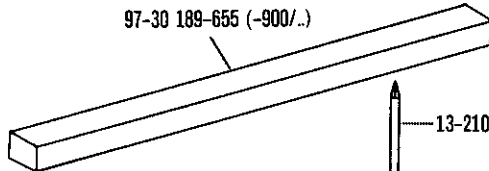

13-210 291-05

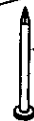

siehe Seite 30
 see page 30
 voir page 30
 véase la página 30

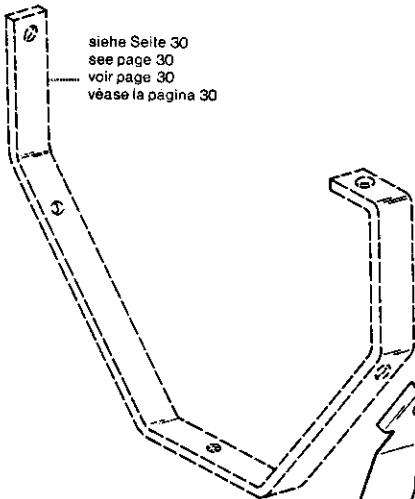

91-032 087



91-129 101-71/994

11-460 157

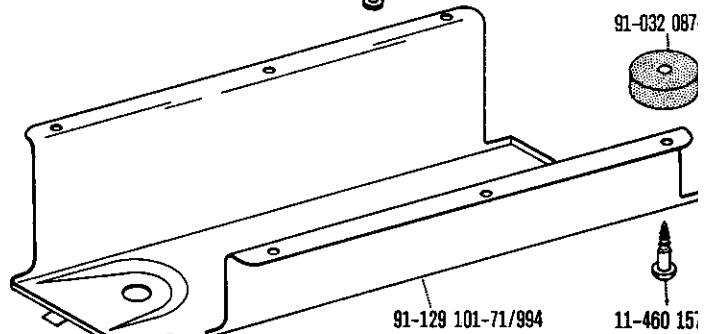

11-130 906-15

91-176 062-15

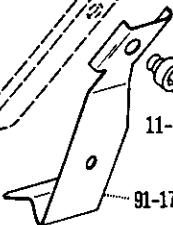

91-166 879-91

91-029 811-05

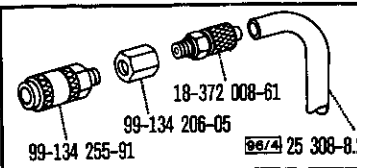

18-372 008-61

99-134 206-05

99-134 255-91

99-134 255-91

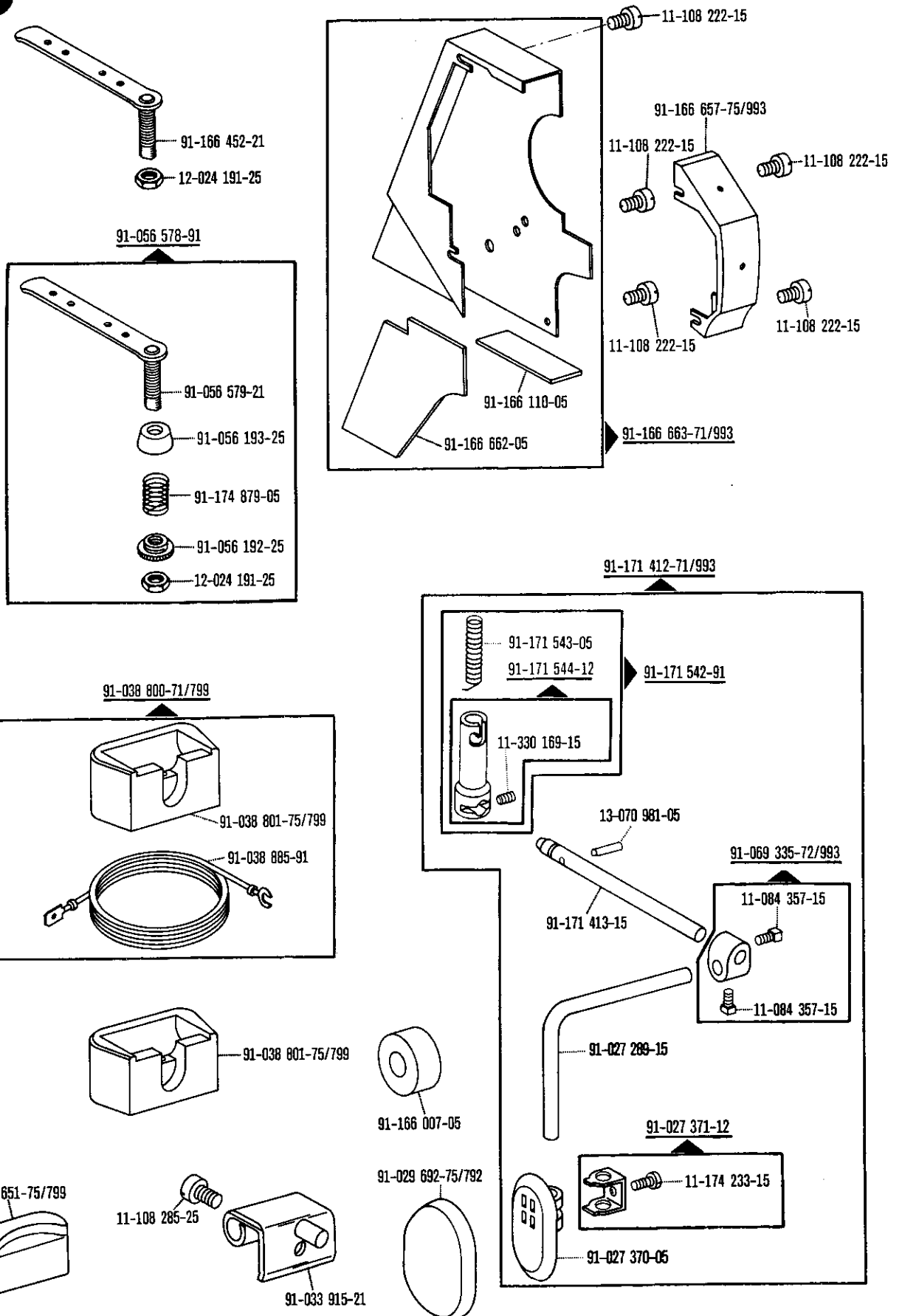

91-129 654-70/994

91-029 039-70/994

91-129 783-71/994

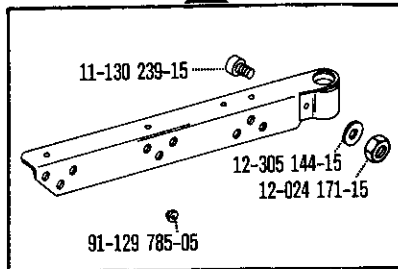

91-129 783-71/994

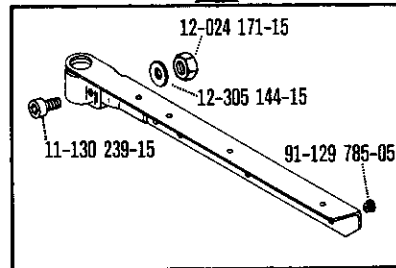

99-115 037-45

91-129 159-70/994

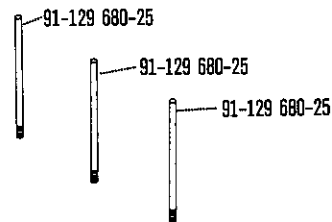
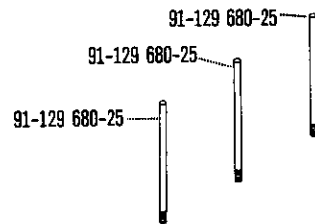
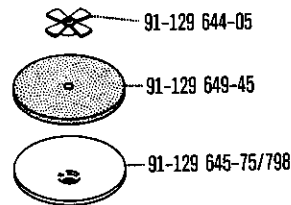
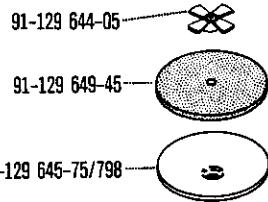
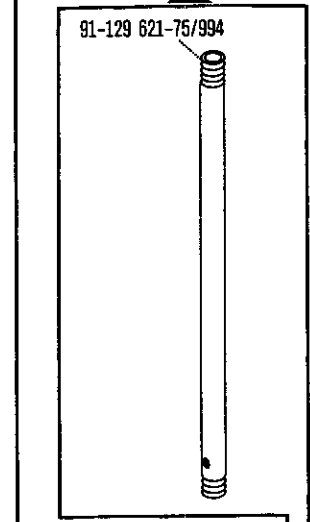

91-129 118-75/994

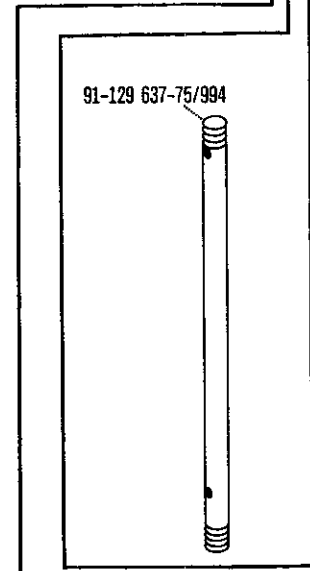

91-129 784-71/994

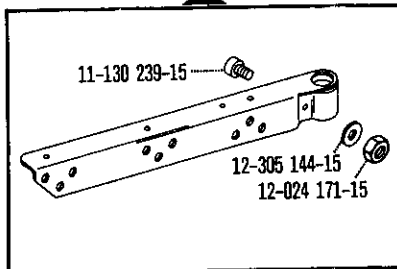

91-129 784-71/994

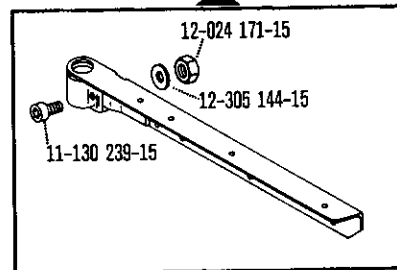

12-005 195-15

12-005 195-15

99-115 034-15
 12-305 414-15
 12-305 414-15
 99-115 034-15

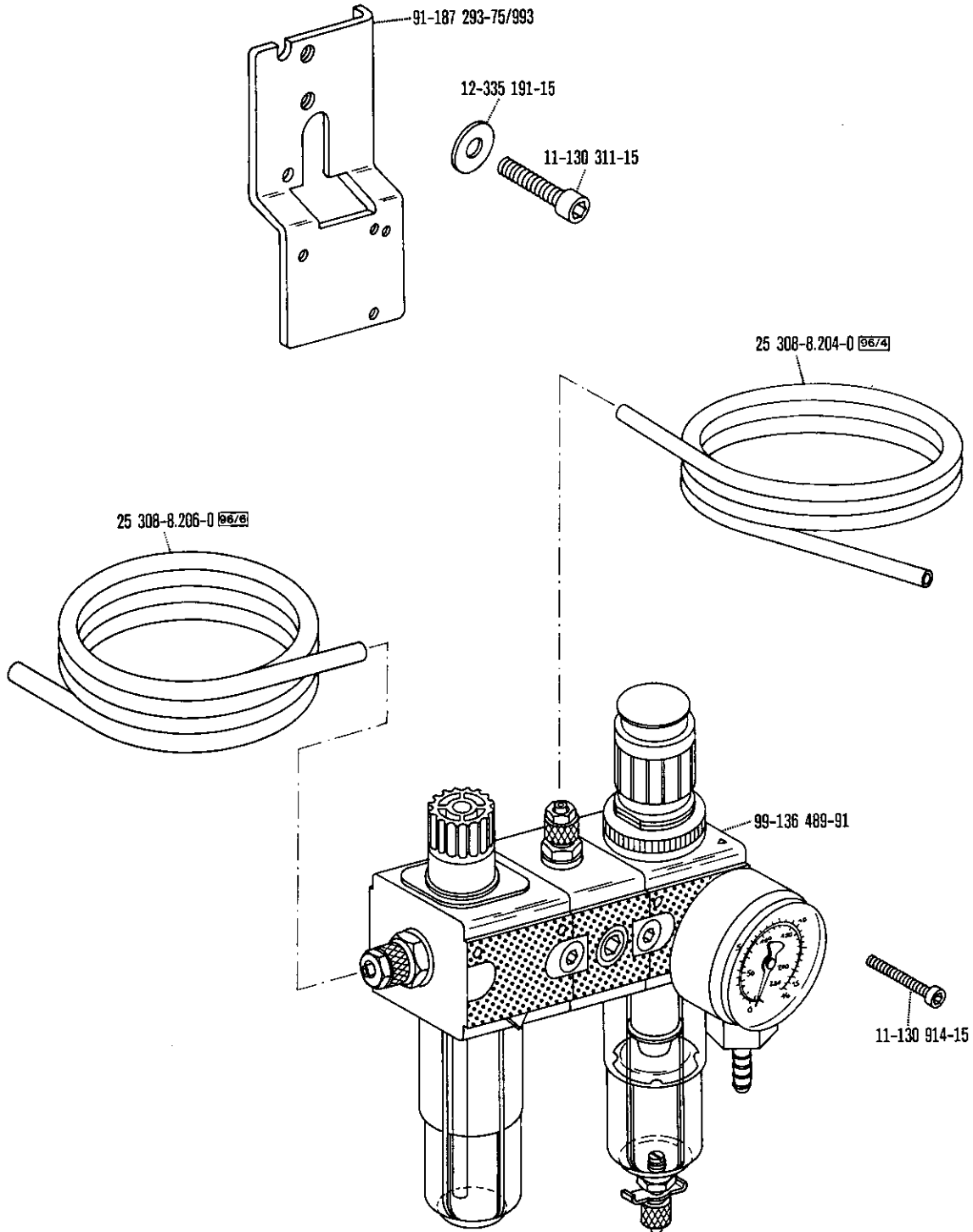

91-171 462-70/993

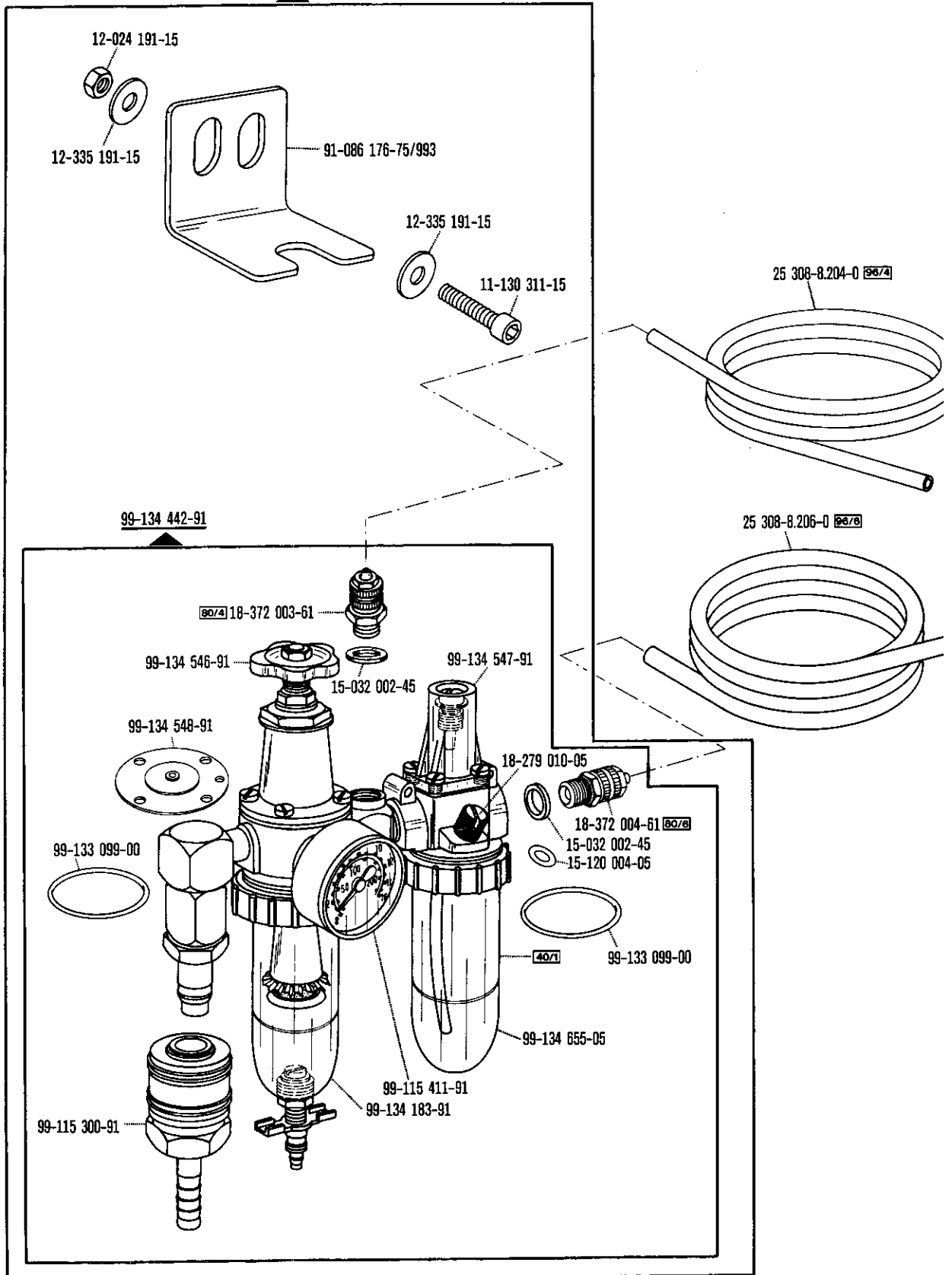

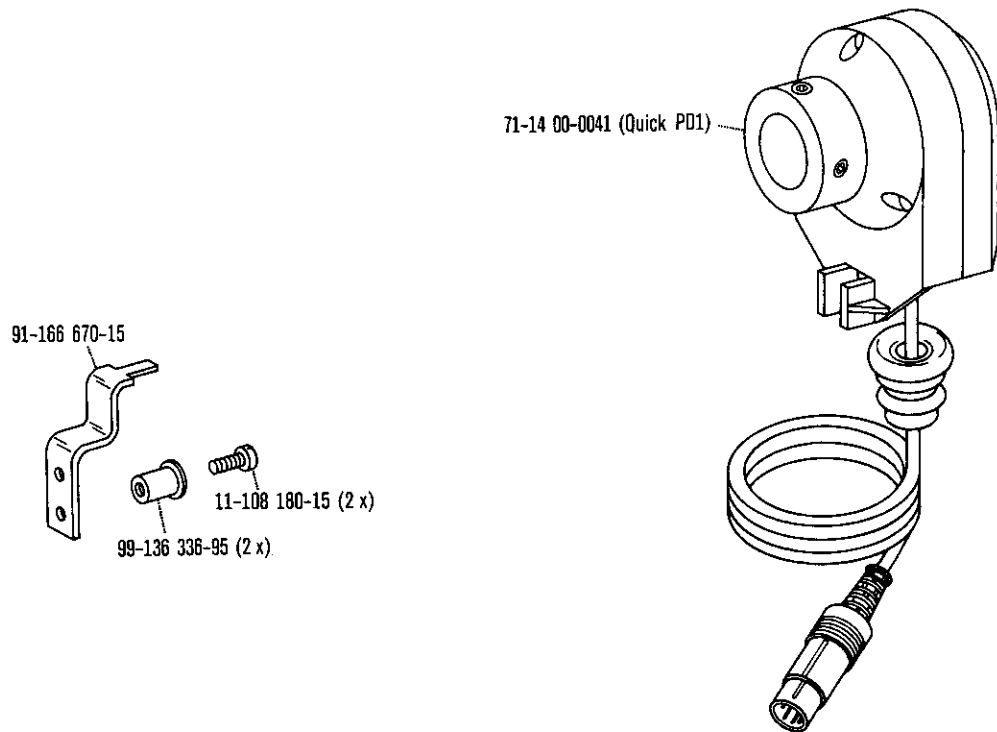
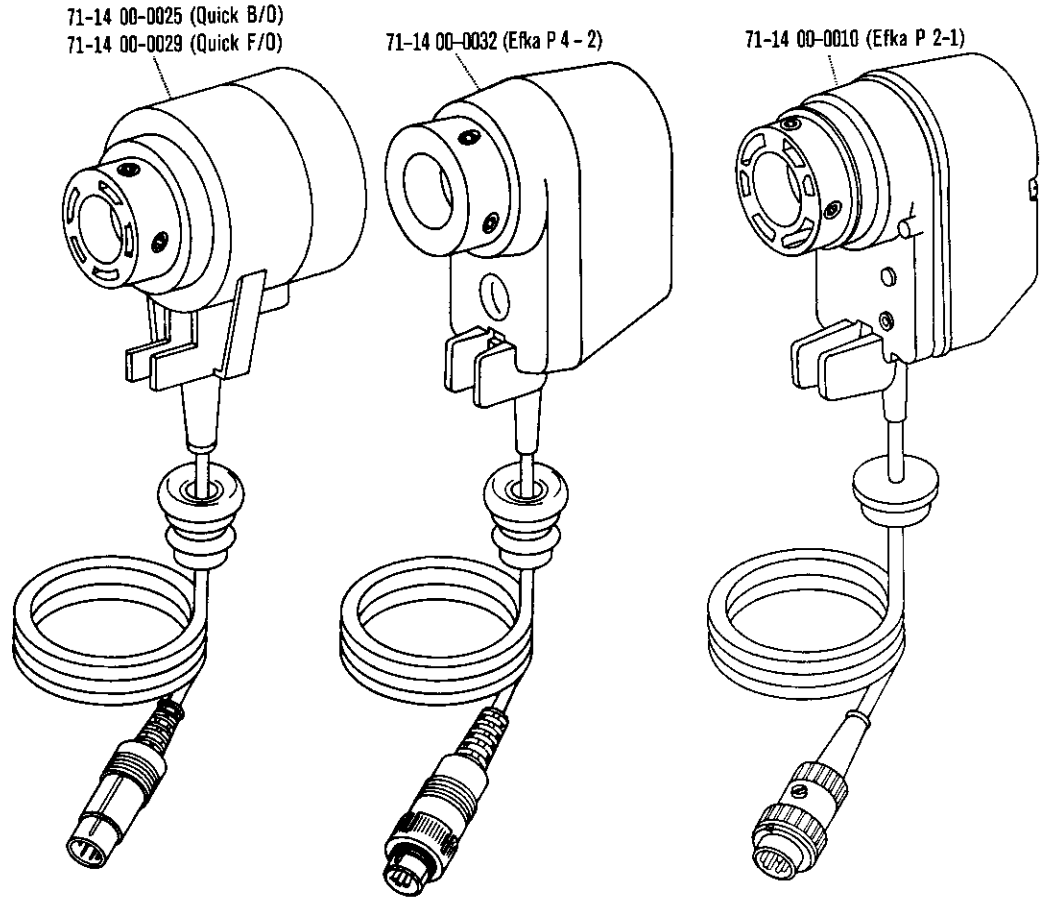

Adjustment gauges
Calibres
Calibres de ajuste

zur · pour
for · para Pfaff 422-720/04
Pfaff 1422-720/04

2

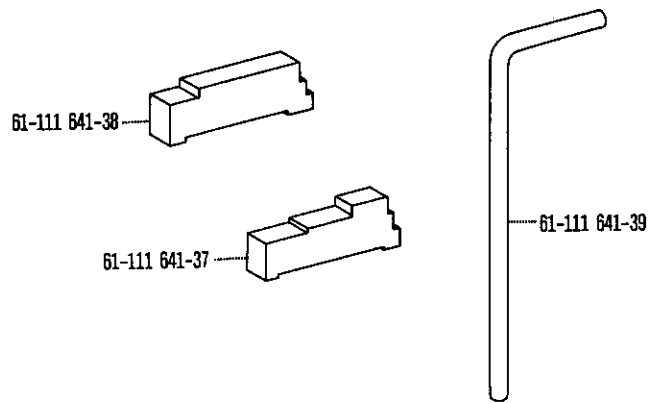

Motoranschlußsatz
Motor connection kit

Jeu de pièces à raccorder le moteur
Juego de piezas de conexión del motor

zur · pour
for · para Pfaff 422-720/04
Pfaff 1422-720/04

2

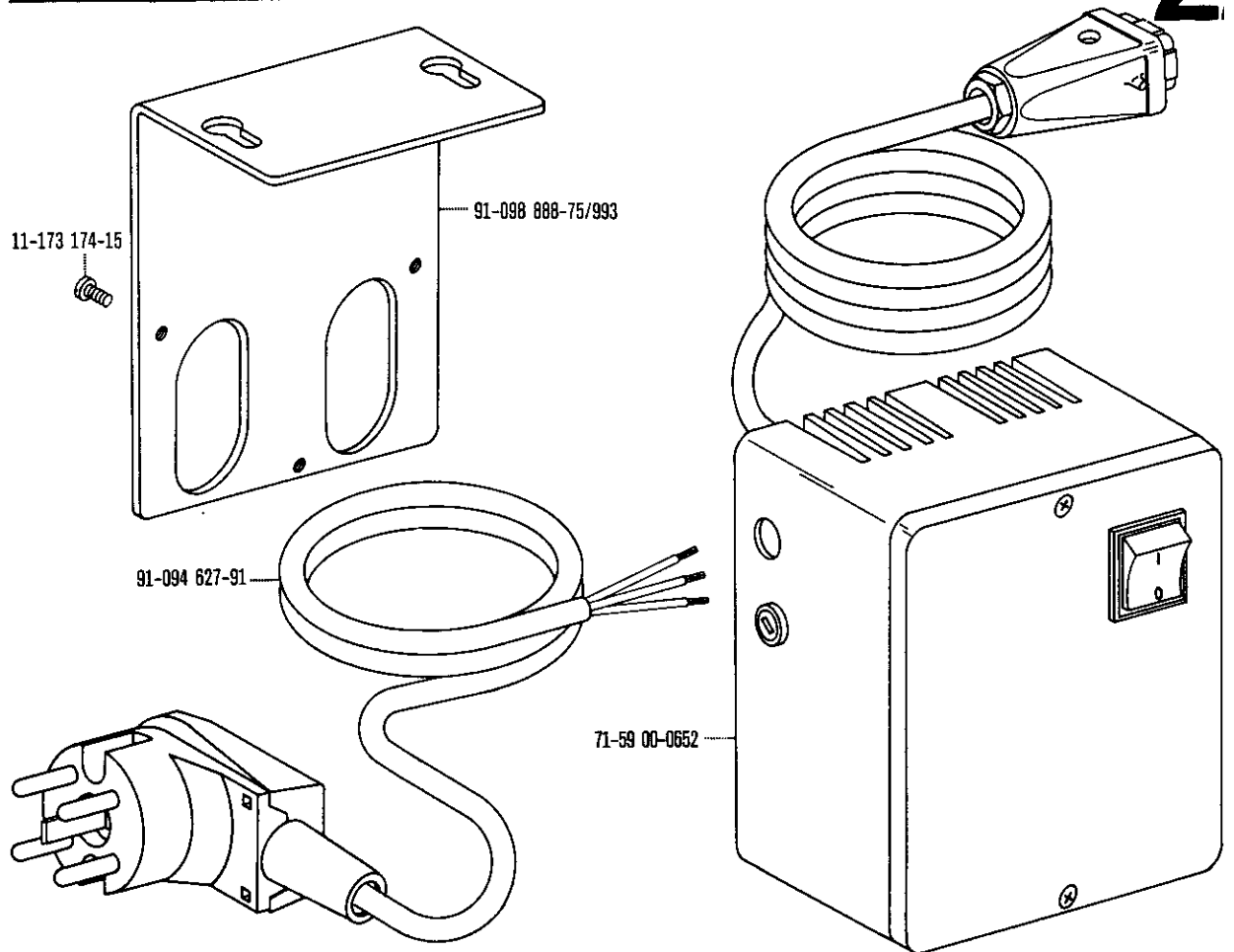

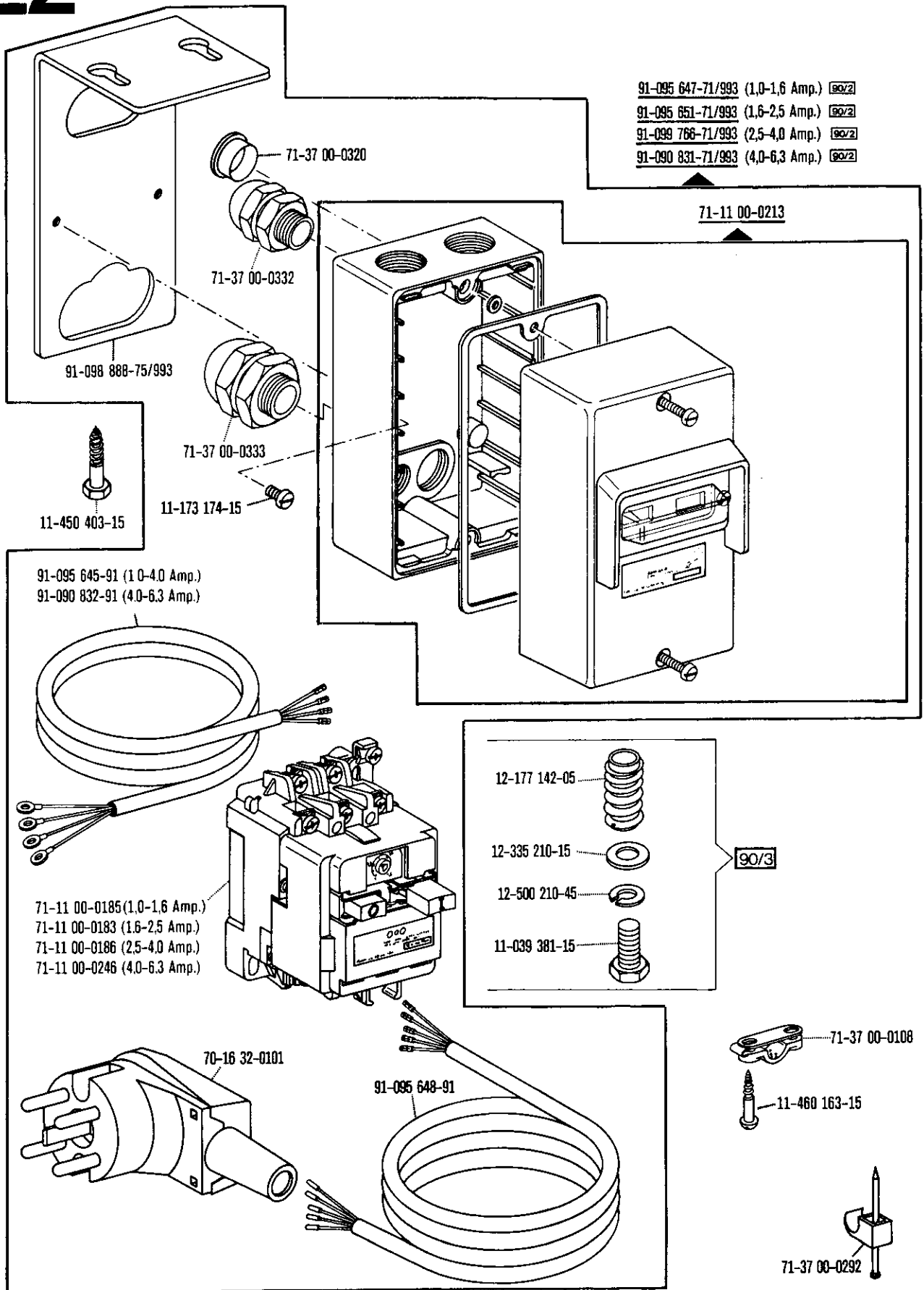

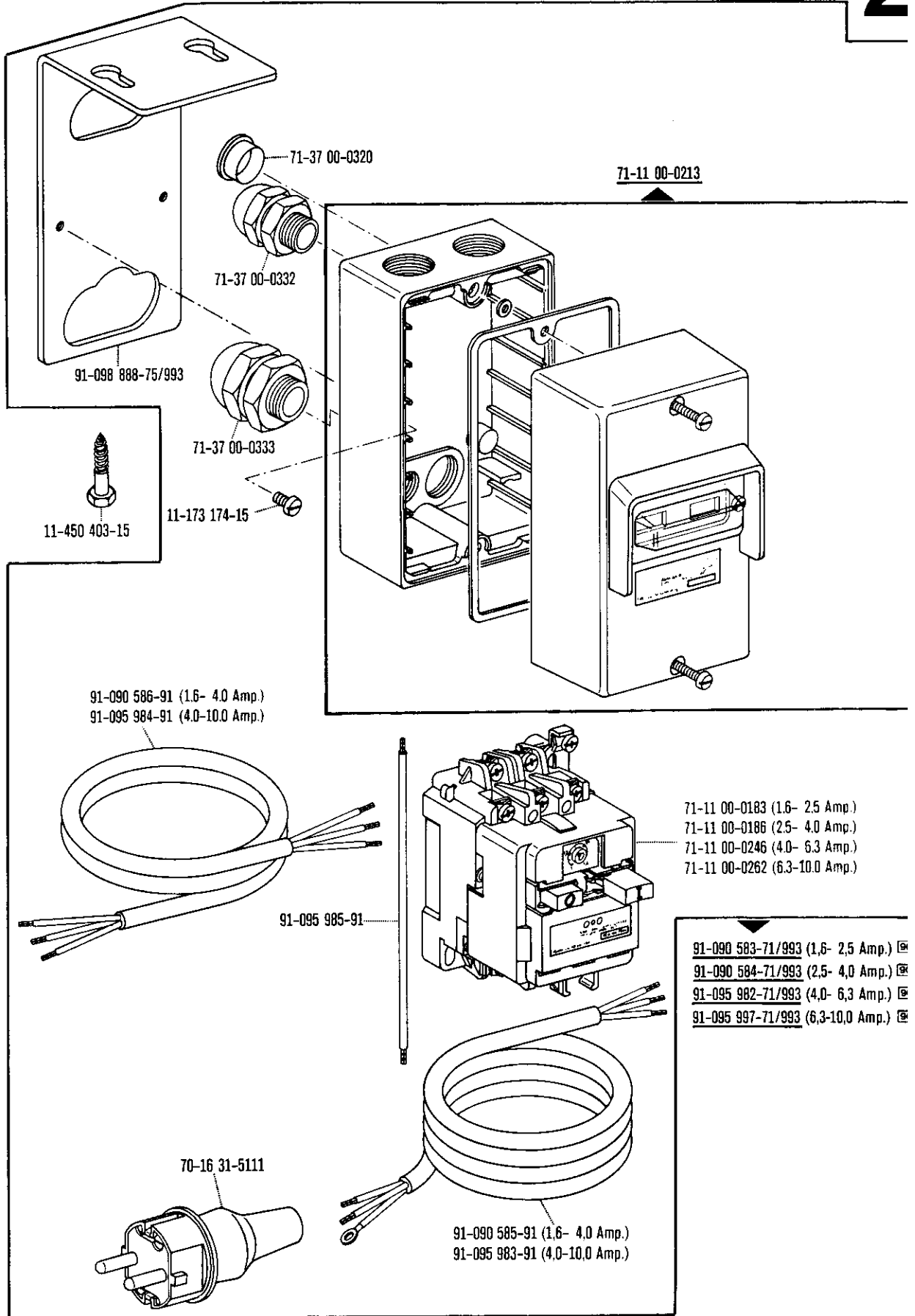

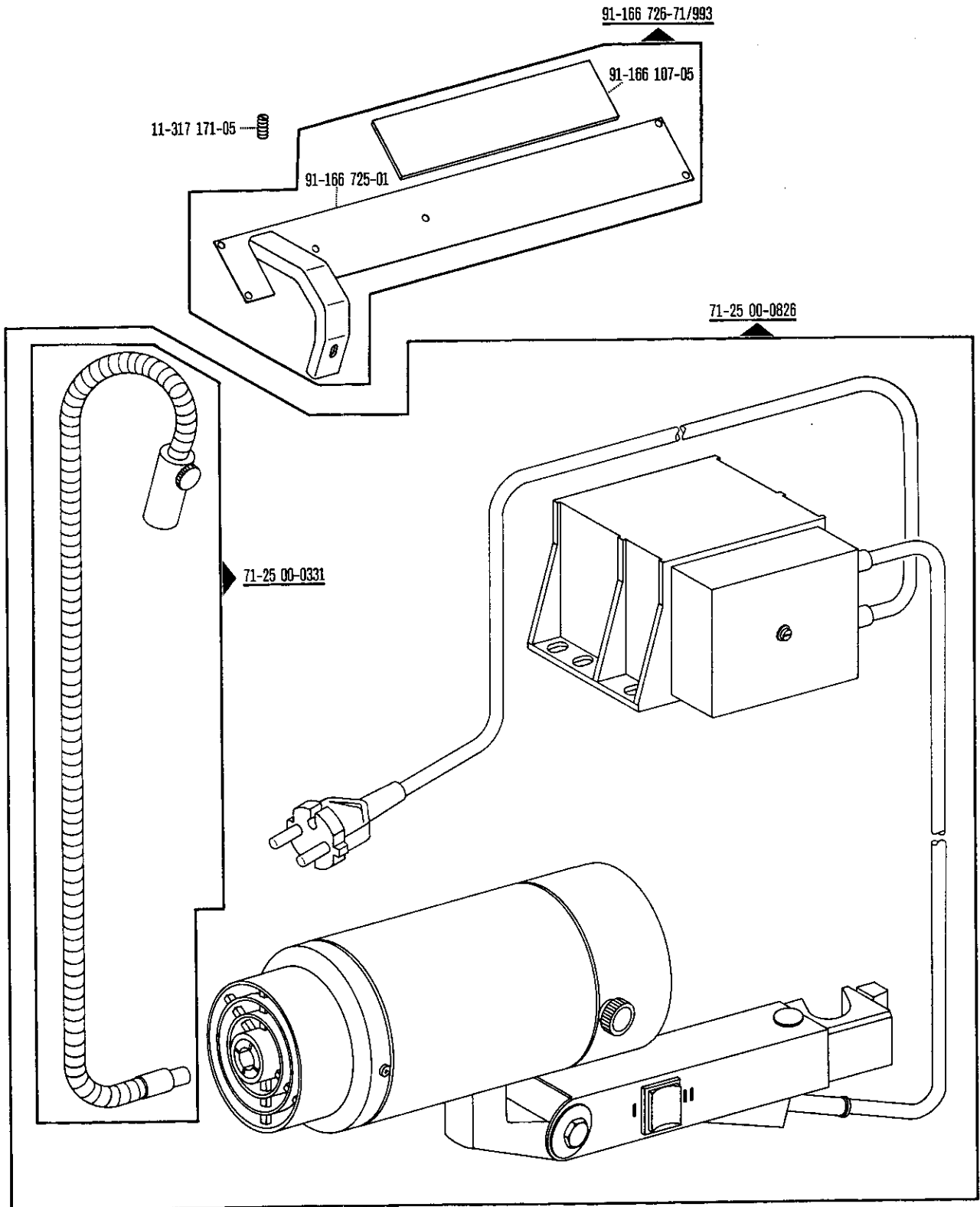



Keilriemenscheiben-Tabelle
Table of V-belt pulleys
Tableau des poulies à gorge en V
Tabla de poleas para correas en "V"

Nähgeschwindigkeit max. Stiche/min Maximum sewing speed in s.p.m. Nombre de points max./mn Número máx. de puntadas por minuto	Motordrehzahl U/min Motor speed in r.p.m. Régime moteur en tours/mn Régimen del motor en r.p.m.	Frequenz Frequency Fréquence Frecuencia	Handrad-Durchmesser ¹⁾ in mm Balance wheel diameter ¹⁾ in mm Diamètre du volant ¹⁾ en mm Diámetro del volante ¹⁾ en mm	Keilriemenscheiben-Durchmesser ¹⁾ in mm V-belt pulley diameter ¹⁾ in mm Diamètre de la poulie à gorge ¹⁾ en mm Diámetro de la polea para correa en "V" ¹⁾ en mm	Teilenummer der Keilriemenscheibe Part number of V-belt pulley Numéro de pièce des poulies à gorge en V № de las piezas de poleas para correas
Pfaff 422-720/04 Pfaff 1422-720/04					
3500	2800	50 Hz	75	80	16-437 050-5
3500	3400	60 Hz	75	67	16-437 020-5

siehe Erläuterungen Register 0

¹⁾ Wirksamer Durchmesser

No.	Seite Page Pages Página	No.	Seite Page Pages Página	No.	Seite Page Pages Página	No.	Seite Page Pages Página
11-039 222-15	53	11-108 846-15	62	11-132 217-15	16	11-210 210-15	23, 24, 27, 28, 41, 42, 45, 46
11-039 381-15	72	11-130 089-15	9, 10, 58	11-132 223-15	40, 42, 43, 44, 46, 50	11-210 216-15	16, 30
11-084 357-15	66	11-130 092-15	17, 50, 60, 63	11-135 223-15	22, 24, 25, 26, 28, 29, 30	11-210 279-15	14
11-106 947-15	33, 62	11-130 097-15	39	11-135 226-15	12	11-225 184-15	63
11-108 084-15	21	11-130 101-15	39, 54	11-135 238-15	17	11-225 223-15	50
11-108 093-15	21, 24, 25, 28, 29	11-130 169-15	11	11-135 292-15	10, 17	11-225 312-15	52, 55, 57
11-108 111-15	53	11-130 170-15	39	11-135 538-15	30	11-250 076-25	37, 64
11-108 120-25	53, 60	11-130 176-15	13, 18, 33, 37, 48, 49, 53	11-172 127-25	9, 58	11-250 084-25	14
11-108 168-15	35	11-130 179-15	21, 32, 39, 50	11-173 171-15	33	11-250 090-15	15
11-108 169-95	17, 30	11-130 179-25	34	11-173 174-15	33, 71, 72, 73	11-250 166-15	33
11-108 171-15	23, 24, 27, 28, 41, 42, 45, 46, 65	11-130 206-15	31	11-173 222-15	16, 53, 54, 60	11-305 299-15	54
11-108 171-25	16, 25, 29	11-130 224-15	16, 19, 25, 30, 32, 36, 47, 53, 54, 60	11-174 089-25	17	11-305 305-15	54
11-108 174-15	10, 16, 19, 21, 34, 35, 51, 53, 54, 60	11-130 227-15	14, 36	11-174 176-15	9	11-305 314-15	15
11-108 177-15	62	11-130 233-15	12, 18, 21, 30	11-174 233-15	66	11-314 166-15	49
11-108 180-15	64, 70	11-130 239-15	12, 30, 52, 55, 57, 67	11-174 915-15	48	11-314 280-15	10, 50
11-108 186-25	35	11-130 245-15	12	11-180 169-95	60	11-314 946-15	9, 25, 29, 58
11-108 192-15	22, 24, 40, 42	11-130 251-15	53	11-187 009-15	54, 58	11-314 964-15	49
11-108 192-25	35	11-130 281-15	15	11-187 012-15	54	11-315 917-05	15
11-108 198-15	26, 28, 44, 46	11-130 284-15	32, 33	11-210 035-25	61	11-317 171-05	74
11-108 204-15	35	11-130 287-15	31, 33, 34, 37, 48, 49	11-210 038-15	29, 47	11-317 949-15	11, 12
11-108 219-15	31	11-130 293-15	14, 20, 48, 49	11-210 038-25	23, 25, 27, 41, 43, 45	11-317 950-15	23, 24, 27, 28, 41, 42, 45, 46
11-108 222-15	54, 66	11-130 299-15	11, 13	11-210 044-15	22, 25, 26, 29, 40, 43, 44, 47	11-330 082-15	11
11-108 222-25	12, 30, 31, 35	11-130 299-15	11, 13	11-210 074-15	62	11-330 085-15	54
11-108 225-15	18, 30	11-130 305-15	11, 23, 24, 27, 28, 33, 41, 42, 45, 46	11-210 078-15	22, 24, 26, 28, 40, 42, 44, 46	11-330 088-15	34
11-108 234-15	15	11-130 311-15	68, 69	11-210 081-15	49, 51, 54	11-330 166-15	9, 13, 32
11-108 240-25	31	11-130 533-15	30	11-210 165-25	30	11-330 169-15	52, 55, 57, 66
11-108 250-25	30, 31	11-130 906-15	34, 53, 60, 65	11-210 168-15	20, 35, 62	11-330 172-15	12, 32
11-108 255-15	30, 49	11-130 914-15	63, 68	11-210 168-25	14	11-330 217-15	34, 35, 41, 42, 45, 46
11-108 285-15	30	11-132 169-15	9	11-210 174-15	21, 22, 24, 26, 28, 40, 42, 44, 46	11-330 220-05	17, 60
11-108 285-25	66	11-132 172-15	49, 50	11-210 186-15	21	11-330 220-15	9, 60
11-108 294-15	30					11-330 223-15	12, 13, 18

No.	Seite Page Pages Página	No.	Seite Page Pages Página	No.	Seite Page Pages Página	No.	Seite Page Pages Página
11-330 283-15	11	12-024 231-25	32	12-610 200-45	17, 21, 22, 24, 26, 28, 40, 42, 46	13-060 400-05	30
11-330 952-15	10, 12, 18, 33, 35	12-177 142-05	72	12-610 210-45	9, 31	13-060 902-05	13
11-330 955-15	11, 41, 42, 45, 46	12-305 084-15	39	12-610 230-45	34	13-060 903-05	11
11-330 960-15	10, 12, 13, 20, 21	12-305 084-25	9, 58	12-610 240-45	17	13-060 904-05	13
11-330 964-15	19	12-305 114-15	21, 33	12-610 250-45	15, 17, 35, 48	13-064 259-05	49
11-335 902-15	14, 20, 21, 36	12-305 144-15	12, 36, 53, 67	12-610 280-45	19	13-064 388-05	18, 30
11-341 217-15	54	12-305 174-15	13, 20, 33, 49, 54	12-610 290-45	20	13-065 088-05	20
11-341 901-15	15, 21	12-305 414-15	67	12-610 310-45	11	13-070 981-05	52, 55, 57, 66
11-341 902-15	14, 18, 20, 22, 25, 26, 29, 31, 34, 40, 43, 44, 47	12-315 080-15	50, 63	12-610 330-45	31	13-210 291-05	65
11-341 905-15	9, 14, 20, 22, 23, 24, 25, 26, 27, 28, 29, 31, 40, 41, 42, 43, 44, 45, 46, 47	12-315 090-15	58	12-618 080-45	21	14-010 173-01	18, 34
11-347 301-15	18	12-315 090-25	9	12-618 290-45	21	14-012 555-01	31
11-450 103-15	73	12-315 110-15	62, 65	12-624 210-45	50	14-012 562-01	22, 24, 26, 28, 40, 42, 44, 46
11-450 403-15	72	12-315 170-15	32	12-640 130-55	14, 34, 35, 52, 55, 56, 60	14-016 120-01	21
11-460 157-15	65	12-335 191-15	23, 24, 27, 28, 41, 42, 45, 46, 68, 69	12-640 150-55	34, 36, 52, 54, 55, 56	14-016 150-01	12
11-460 163-15	72	12-335 210-15	72	12-640 170-55	10, 15, 32, 33	14-016 151-91	14, 22, 25, 26, 29, 31, 40, 43, 44, 47
11-460 310-15	64	12-360 054-05	50	12-640 190-55	50	14-016 153-01	14, 22, 25, 26, 29, 31, 40, 43, 44, 47
11-724 270-55	16	12-360 063-05	9	12-640 200-55	50	14-016 171-91	48
11-724 290-55	16	12-360 103-25	36, 48	12-640 220-55	10	14-016 173-01	48
12-005 154-15	9, 54, 58	12-360 173-05	17	12-660 430-45	35	14-018 590-01	35
12-005 175-15	36, 52, 55, 56	12-361 156-15	14	12-703 161-12	54	14-018 613-01	20, 21
12-005 195-15	18, 54, 67	12-500 111-45	62	13-030 310-05	15	14-018 614-91	20, 21
12-024 101-15	62	12-500 151-45	62	13-030 389-05	18	14-018 643-01	12
12-024 121-15	39, 51	12-500 210-45	72	13-033 004-05	23, 24, 27, 28, 41, 42, 45, 46	14-018 644-91	12
12-024 151-15	10, 21, 35, 62	12-505 150-45	9, 33, 58	13-033 322-05	11	14-026 122-01	22, 24, 26, 28, 40, 42, 44, 46
12-024 151-25	9, 58	12-505 190-45	58	13-033 469-05	15	14-215 007-05	34
12-024 171-15	12, 48, 49, 52, 55, 57, 67	12-517 200-45	34	13-033 556-05	35	14-215 013-03	13
12-024 191-15	15, 20, 69	12-517 250-45	35	13-050 046-15	23, 25, 27, 29, 41, 43, 45, 47, 61	14-215 013-13	9, 19, 34, 36
12-024 191-25	66	12-518 230-45	34	13-052 142-15	50	14-215 022-13	22, 24, 25, 26, 28, 29, 34, 40, 42, 43, 44, 46, 47
		12-610 170-45	22, 24, 25, 26, 28, 29, 40, 42, 43, 44, 46, 47	13-052 262-15	35		
		12-610 190-45	34	13-060 316-05	30, 49		

No.	Seite Page Pages Página	No.	Seite Page Pages Página	No.	Seite Page Pages Página	No.	Seite Page Pages Página
14-215 028-13	15, 20, 35	15-120 904-05	33	71-11 00-0186	72, 73	71-59 00-0652	71
14-215 043-43	32	15-120 911-05	59	71-11 00-0213	72, 73	71-75 00-0054	38
14-215 046-13	13	15-120 916-05	22, 24, 26, 28, 40, 42, 44, 46	71-11 00-0246	72, 73	71-75 00-0150	38
14-215 049-43	34	15-120 919-05	35	71-11 00-0262	73	71-75 00-0152	38
14-215 070-13	12, 13	15-125 020-05	21	71-14 00-0010	70	71-75 00-0153	38
14-215 118-13	19	15-256 055-01	35	71-14 00-0025	70	71-85 00-0073	38
14-215 124-13	19	15-280 022-01	35	71-14 00-0029	70	71-85 00-0091	62
14-215 157-13	12	16-409 916-05	32	71-14 00-0032	70	91-000 219-05	23, 25, 27, 29, 41, 43, 45, 47, 61
14-215 166-13	11	16-437 020-55	75	71-14 00-0041	70	91-000 390-05	23, 25, 27, 29, 41, 43, 45, 47, 61
14-215 199-43	20	16-437 050-55	75	71-16 00-0187	62	91-000 529-15	23, 25, 27, 29, 41, 43, 45, 47, 61
14-215 382-13	13	17-028 318-61	35	71-17 00-0131	39	91-000 742-15	9, 58
14-215 904-13	18	17-035 232-45	32	71-21 00-0174	39	91-000 928-15	23, 25, 27, 29, 41, 43, 45, 47, 61
14-215 905-13	12	17-035 232-65	35	71-25 00-0294	38	91-001 283-15	34
14-218 040-01	33	18-278 005-91	63	71-25 00-0331	74	91-001 522-25	58
14-602 901-01	14	18-279 010-05	63, 69	71-25 00-0826	74	91-002 065-05	9, 58
14-650 243-05	21, 53	18-372 003-91	69	71-31 00-0036	38	91-002 262-25	9
14-650 251-05	20	18-372 004-91	69	71-31 00-0037	38	91-006 525-05	10
14-650 275-05	21	18-372 008-91	16, 53, 60, 63, 65	71-31 00-0070	38	91-006 526-05	10
14-680 030-15	20, 21	18-378 008-91	12, 54	71-31 00-0084	38	91-006 584-05	9, 58
14-680 060-15	14, 22, 25, 26, 29, 31, 40, 43, 44, 47	18-378 008-91	52, 55, 57, 59, 60, 63	71-31 00-0090	38	91-006 617-05	22, 25, 26, 29, 40, 43, 44, 47
14-680 070-15	12, 48	18-379 008-91	59	71-37 00-0108	72	91-010 178-05	23, 25, 41, 43
14-720 170-05	33	40-754 701-00	65	71-37 00-0132	12, 39, 59	91-010 181-15	58
15-032 001-45	63	51-236 010-30	36	71-37 00-0133	39	91-010 183-05	9
15-032 001-55	21	61-111 641-37	71	71-37 00-0135	21, 51	91-010 185-05	9
15-032 002-45	69	61-111 641-38	71	71-37 00-0136	24, 25, 28, 29	91-010 546-05	59
15-032 006-45	16, 53, 54, 60, 63	61-111 641-39	71	71-37 00-0292	72	91-011 374-05	17
15-120 002-05	21	70-16 31-5111	73	71-37 00-0320	72, 73	91-011 391-05	30
15-120 004-05	69	70-16 32-0101	72	71-37 00-0332	72, 73	91-011 391-45	30
15-120 707-05	23, 25, 27, 29, 41, 43, 45, 47, 61	71-11 00-0183	72, 73	71-37 00-0333	72, 73	91-018 293-05	23, 27, 29, 41, 45, 47, 61
15-120 718-05	17, 34, 60	71-11 00-0185	72	71-59 00-0591	51		
				71-59 00-0623	64		
				71-59 00-0630	38		

No.	Seite Page Pages Página	No.	Seite Page Pages Página	No.	Seite Page Pages Página	No.	Seite Page Pages Página
91-018 293-15	25, 43	91-069 292-05	30	91-095 982-71/993	73	91-118 144-05	50
91-018 439-05	27, 29, 45, 47, 61	91-069 335-72/993	66	91-095 983-91	73	91-118 148-05	15
91-018 480-05	29, 65	91-069 471-25	9, 58	91-095 984-91	73	91-118 149-91	22, 25, 26, 29, 40, 43, 44, 47
91-018 578-05	32	91-086 176-75/993	69	91-095 985-91	73	91-118 150-71/951	30
91-019 891-05	23, 25, 41, 43	91-089 467-05	38, 52, 55, 56	91-095 997-71/993	73	91-118 151-05	30
91-020 490-15	15, 52, 55, 57	91-089 769-15	62	91-098 827-15	32	91-118 152-05	30
91-021 123-05	65	91-090 583-71/993	73	91-098 888-75/993	71, 72, 73	91-118 154-90	23, 24, 27, 28, 41, 42, 45, 46
91-021 296-05	21	91-090 584-71/993	73	91-099 766-71/993	72	91-118 178-07	19
91-027 289-15	66	91-090 585-91	73	91-100 055-25	59	91-118 184-05	21
91-027 370-05	66	91-090 586-91	73	91-100 270-25	59	91-118 188-05	21
91-027 371-12	66	91-090 751-05	39	91-100 281-25	14	91-118 192-05	21
91-027 630-91	5	91-090 823-91	39	91-101 920-05	31	91-118 200-91	22, 25, 26, 29, 40, 43, 44, 47
91-027 651-75/799	66	91-090 831-71/993	72	91-101 922-05	9, 58	91-118 201-15	22, 25, 26, 29, 40, 43, 44, 47
91-028 293-05	47	91-090 832-91	72	91-101 923-05	58	91-118 275-93	14
91-029 007-91	65	91-094 482-71/995	62	91-105 447-15	58	91-118 308-05	25, 65
91-029 033-45	65	91-094 619-91	16	91-105 447-25	9	91-118 430-25	9
91-029 039-70/994	67	91-094 627-91	71	91-106 272-12	34	91-118 504-92	19
91-029 692-72/792	66	91-094 711-91	16	91-107 266-05	34	91-118 569-04	14
91-029 811-05	65	91-094 737-91	39	91-107 886-15	17	91-118 570-92	14
91-029 946-91	65	91-094 739-91	55, 57	91-113 023-92	58	91-118 600-91	19
91-032 087-45	65	91-094 741-91	55, 56	91-113 023-93	9	91-118 609-15	15
91-033 915-21	66	91-094 743-91	16	91-113 024-92	41, 42, 45, 46	91-118 612-05	15
91-038 800-71/799	66	91-094 744-91	16	91-113 027-15	9, 58	91-118 669-05	21
91-038 801-75/799	66	91-094 745-91	54	91-113 445-15	52, 55, 56, 60	91-118 681-05	14
91-038 885-91	66	91-094 914-71/799	64	91-118 019-91	15	91-118 682-05	14
91-056 192-25	66	91-094 936-91	60	91-118 022-05	18, 49	91-118 683-05	14
91-056 193-25	66	91-094 965-91	62	91-118 044-91	19	91-118 685-05	14
91-056 578-91	66	91-095 645-91	72	91-118 045-91	19	91-118 703-11	23, 24, 27, 28, 41, 42, 45, 46
91-069 042-01	13	91-095 647-71/993	72	91-118 048-91	22, 25, 26, 29, 40, 43, 44, 47	91-118 704-15	23, 24, 27, 28, 41, 42, 45, 46
91-069 079-72/995	10	91-095 648-91	72	91-118 098-25	14		
91-056 579-21	66	91-095 651-71/993	72	91-118 137-91	21		
91-069 259-05	21	91-095 850-91	39	91-118 138-93	21		

No.	Seite Page Pages Página	No.	Seite Page Pages Página	No.	Seite Page Pages Página	No.	Seite Page Pages Página
91-118 707-12	22, 24, 26, 28, 40, 42, 44, 46	91-118 898-05	20	91-129 920-91	5	91-166 023-05	30
91-118 708-15	24, 28, 42, 46	91-118 901-12	20	91-130 035-07	49	91-166 024-92	11
91-118 709-15	23, 27, 41, 45	91-118 931-05	14	91-131 019-15	48	91-166 026-92	11
91-118 711-05	23, 24, 25, 27, 28, 29, 41, 42, 43, 45, 46, 47	91-118 934-91	14	91-135 890-91	12	91-166 027-91	11
91-118 717-72/995	25, 29	91-118 937-01	14	91-140 239-05	23, 24, 27, 28, 41, 42, 45, 46	91-166 031-05	11
91-118 741-02	23, 25, 27, 29, 41, 43, 45, 47	91-118 939-21	14	91-140 528-91	14	91-166 032-12	11
91-118 759-92	22, 25, 26, 29, 40, 43, 44, 47	91-118 940-05	14	91-140 529-05	14	91-166 033-05	11
91-118 762-05	22, 24, 26, 28, 40, 42, 44, 46	91-119 019-05	32	91-140 676-05	22, 24, 26, 28, 40, 42, 44, 46	91-166 034-01	10
91-118 764-01	22, 25, 26, 29, 40, 43, 44, 47	91-119 049-05	9	91-140 945-05	23, 25, 27, 29, 41, 43, 45, 47, 61	91-166 036-12	10
91-118 765-05	22, 25, 26, 29, 40, 43, 44, 47	91-119 085-05	19	91-141 402-05	50	91-166 037-25	10
91-118 766-05	22, 25, 26, 29, 34, 35, 40, 43, 44, 47	91-119 120-91	21	91-150 177-91	37	91-166 038-91	12
91-118 782-72/951	27, 28	91-119 121-12	21	91-160 190-91	54	91-166 039-05	12
91-118 787-15	22, 24, 26, 28, 40, 42, 44, 46	91-119 704-91	14	91-162 526-05	20	91-166 040-05	12
91-118 790-07	23, 24, 27, 28, 41, 42, 45, 46	91-119 705-12	14	91-162 631-05	23, 25, 41, 43	91-166 041-05	12
91-118 857-05	15	91-129 101-71/994	65	91-162 632-91	23, 25, 41, 43	91-166 042-05	12
91-118 866-15	21	91-129 118-75/994	67	91-162 633-05	23, 25, 41, 43	91-166 043-05	12
91-118 880-91	19	91-129 139-01	65	91-162 634-05	23, 25, 41, 43	91-166 044-05	12
91-118 881-15	19, 36	91-129 153-91	65	91-162 635-05	22, 24, 40, 42	91-166 045-92	12
91-118 882-92	19, 36	91-129 159-70/994	67	91-163 088-75/789	17	91-166 048-05	11
91-118 883-05	19, 36	91-129 621-75/994	67	91-166 000-71/995	30	91-166 049-05	13
91-118 884-45	19, 36	91-129 637-75/994	67	91-166 001-75/995	30	91-166 050-05	12
91-118 886-92	19	91-129 644-05	67	91-166 007-05	66	91-166 050-92	12
91-118 887-05	19, 36	91-129 645-75/798	67	91-166 008-92	12	91-166 051-91	13
91-118 888-05	19	91-129 649-45	67	91-166 009-91	9	91-166 053-04	13
91-118 889-12	19	91-129 654-70/994	67	91-166 013-04	9	91-166 054-04	13
91-118 894-05	19	91-129 680-25	67	91-166 015-91	11	91-166 055-05	13
		91-129 783-71/994	67	91-166 016-91	11	91-166 056-05	13
		91-129 784-71/994	67	91-166 017-01	11	91-166 057-05	13
		91-129 785-05	67	91-166 021-04	11	91-166 058-05	13
		91-129 916-91	5	91-166 022-05	11	91-166 059-05	13
		91-129 917-91	5			91-166 060-04	13
		91-129 919-91	5			91-166 061-05	13

No.	Seite Page Pages Página	No.	Seite Page Pages Página	No.	Seite Page Pages Página	No.	Seite Page Pages Página
91-166063-92	13	91-166 120-91	54	91-166 196-72/995	30	91-166 372-71/951	27
91-166065-92	13	91-166 129-15	16, 53, 54, 60	91-166 197-91	16	91-166 373-71/951	45
91-166066-04	13	91-166 130-04	9	91-166 253-91	36	91-166 376-91	28, 44, 46
91-166068-05	13	91-166 131-91	9	91-166 254-92	36	91-166 377-05	26, 28
91-166071-05	13	91-166 148-72/951	20	91-166 255-12	36	91-166 377-15	44, 46
91-166072-45	12	91-166 150-05	11	91-166 256-15	36	91-166 378-07	27, 29, 45, 47, 61
91-166075-72/993	30	91-166 151-05	11	91-166 257-12	36	91-166 379-05	27, 29, 45, 47
91-166077-25	12	91-166 156-71/993	60	91-166 258-05	36	91-166 381-75/951	26, 28, 44, 46
91-166078-75/995	30	91-166 157-75/993	17, 60	91-166 259-15	36	91-166 382-05	26, 28, 44, 46
91-166080-01	30	91-166 158-71/995	17, 60	91-166 260-15	36	91-166 383-14	42
91-166085-05	12	91-166 159-75/995	17, 60	91-166 261-15	36	91-166 383-15	22, 24, 26, 28, 40, 42, 44, 46
91-166087-05	10	91-166 160-15	17, 60	91-166 262-12	36	91-166 384-05	22, 24, 26, 28, 40, 42, 44, 46
91-166088-11	10	91-166 161-71/995	60	91-166 263-15	36	91-166 385-15	23, 24, 27, 28, 41, 42, 45, 46
91-166091-91	12	91-166 162-15	60	91-166 264-15	37	91-166 386-91	23, 24, 27, 28, 41, 42, 45, 46
91-166092-71/995	54	91-166 163-05	17, 60	91-166 265-91	37	91-166 387-91	27, 29, 45, 47
91-166094-04	11	91-166 164-11	17, 60	91-166 278-91	52, 55, 57	91-166 388-05	23, 25, 27, 29, 41, 43, 45, 47
91-166095-15	54	91-166 167-05	60	91-166 279-11	65	91-166 389-05	27, 29, 45, 47, 61
91-166099-71/995	30	91-166 168-05	17, 60	91-166 281-15	52, 55, 57	91-166 390-05	23, 25, 27, 29, 41, 43, 45, 47, 61
91-166102-05	13	91-166 169-05	60	91-166 282-15	52, 55, 57	91-166 390-92	23, 25, 27, 29, 41, 43, 45, 47, 61
91-166103-05	13	91-166 170-05	17, 60	91-166 283-11	52, 55, 57	91-166 391-15	23, 25, 27, 29, 41, 43, 45, 47, 61
91-166104-05	12	91-166 171-05	17, 60	91-166 286-91	50, 63	91-166 392-15	27, 29, 45, 47, 61
91-166105-05	12	91-166 172-11	17, 60	91-166 299-91	21	91-166 394-71/951	20
91-166106-72/993	14	91-166 177-05	17, 60	91-166 301-92	21	91-166 396-11	21
91-166107-05	30, 74	91-166 178-05	17, 60	91-166 311-01	13	91-166 406-91	31
91-166110-05	31, 66	91-166 180-75/993	60	91-166 312-05	13	91-166 407-11	31
91-166113-15	12	91-166 181-71/798	17	91-166 313-05	13	91-166 411-91	31
91-166114-05	54	91-166 182-11	17	91-166 320-05	18	91-166 413-75/993	31
91-166115-15	54	91-166 185-05	17	91-166 322-05	19	91-166 414-75/995	31
91-166116-91	54	91-166 186-12	17	91-166 323-05	21		
91-166117-91	54	91-166 187-12	52, 55, 56	91-166 324-05	21		
91-166118-05	54	91-166 190-91	53, 54, 60	91-166 329-91	19		
91-166119-05	54	91-166 194-75/995	31	91-166 339-91	65		

No.	Seite Page Pages Página	No.	Seite Page Pages Página	No.	Seite Page Pages Página	No.	Seite Page Pages Página
91-166 416-91	33	91-166 620-71/993	17	91-166 814-01	18	91-169 582-05	34
91-166 417-11	33	91-166 621-05	17	91-166 816-91	59	91-169 974-05	21
91-166 420-15	33	91-166 623-75/993	17	91-166 817-25	59	91-170 809-05	12
91-166 421-71/995	33	91-166 630-05	21, 24	91-166 818-25	59	91-171 042-45	14
91-166 422-71/995	33	91-166 657-75/993	66	91-166 819-05	59	91-171 049-05	14
91-166 426-75/995	33	91-166 662-05	31, 66	91-166 821-25	59	91-171 175-12	35
91-166 427-12	33	91-166 663-71/993	66	91-166 822-25	59	91-171 412-71/993	66
91-166 429-71/995	32	91-166 667-71/993	30	91-166 823-25	59	91-171 413-15	66
91-166 430-72/995	33	91-166 670-15	70	91-166 827-05	27, 29, 45, 47	91-171 462-70/993	69
91-166 432-71/995	33	91-166 672-05	13	91-166 828-05	27, 29, 45, 47	91-171 542-91	66
91-166 433-05	33	91-166 676-91	52, 55, 57	91-166 832-71/993	51	91-171 543-05	52, 55, 57, 66
91-166 434-05	33	91-166 677-90	55, 56	91-166 835-05	64	91-171 544-12	52, 55, 57, 66
91-166 435-71/995	32	91-166 691-70/993	60	91-166 836-05	37, 64	91-172 910-05	52, 55, 57
91-166 436-91	32	91-166 696-90	52	91-166 853-91	55, 56	91-173 002-75/995	30
91-166 438-91	32	91-166 717-15	30	91-166 858-75/993	59	91-173 049-05	31
91-166 439-15	32	91-166 718-15	52, 55, 57	91-166 859-75/995	59	91-173 072-05	18
91-166 440-71/995	31	91-166 725-01	74	91-166 864-91	52	91-173 073-05	18
91-166 445-15	53	91-166 726-71/993	74	91-166 874-15	16	91-173 074-72/951	18
91-166 446-91	53	91-166 727-71/993	31	91-166 879-91	65	91-173 079-92	18
91-166 447-05	53	91-166 728-05	23, 25, 41, 43	91-166 893-91	15	91-173 084-05	19
91-166 448-05	53	91-166 729-15	23, 25, 41, 43	91-166 894-15	15	91-173 085-05	20
91-166 449-15	53	91-166 730-05	22, 24, 40, 42	91-166 895-72/951	23, 24	91-173 093-05	18
91-166 451-90	53	91-166 731-75/951	22, 24, 40, 42	91-166 942-71/798	9	91-173 094-15	18
91-166 452-21	66	91-166 732-91	22, 24, 40, 42	91-166 948-70	53	91-173 100-05	17
91-166 493-05	9	91-166 733-91	23, 25, 41, 43	91-167 636-05	49	91-173 102-05	30
91-166 551-91	20	91-166 734-71/951	41	91-168 099-04	31	91-173 106-05	20
91-166 552-02	20	91-166 735-71/951	23	91-168 105-05	34	91-173 133-15	52, 55, 57
91-166 553-05	20	91-166 737-71/993	30	91-168 194-71/798	9	91-173 134-92	52, 55, 57
91-166 554-05	20	91-166 740-01	27, 29, 45, 47, 61	91-168 368-05	24, 28	91-173 139-15	52, 55, 56, 60
91-166 555-92	20	91-166 809-91	27, 29, 45, 47	91-168 480-15	14	91-173 185-05	25, 29, 43, 47
91-166 559-45	30	91-166 811-05	18	91-169 099-75/768	12	91-173 297-01	10
91-166 586-15	13	91-166 812-05	18	91-169 132-15	20	91-173 297-92	10

No.	Seite Page Pages Página	No.	Seite Page Pages Página	No.	Seite Page Pages Página	No.	Seite Page Pages Página
91-173 301-12	21	91-173 843-02	15	91-173 973-14	40	91-174 639-05	34
91-173 304-05	21	91-173 844-91	10	91-173 973-15	22, 24, 25, 26, 28, 29, 40, 42, 43, 44, 46, 47	91-174 640-05	34
91-173 305-91	21	91-173 845-11	10	91-173 975-11	54	91-174 641-12	34
91-173 501-71/951	49	91-173 849-05	10	91-173 976-05	10	91-174 646-05	34
91-173 502-75/951	49	91-173 850-05	10	91-173 988-05	20	91-174 647-05	35
91-173 504-92	49	91-173 854-05	10	91-174 043-05	21	91-174 648-12	35
91-173 505-05	49	91-173 874-11	50	91-174 044-05	21	91-174 649-91	35
91-173 506-05	49	91-173 876-05	50	91-174 328-91	17	91-174 650-91	35
91-173 507-05	49	91-173 877-05	50	91-174 329-05	17	91-174 652-11	35
91-173 509-15	39	91-173 878-05	50	91-174 330-05	17	91-174 654-05	35
91-173 516-05	49	91-173 879-05	50	91-174 609-15	31	91-174 655-05	35
91-173 517-92	49	91-173 880-05	50	91-174 616-71/995	35	91-174 656-92	35
91-173 524-75/951	30, 49	91-173 881-05	50	91-174 617-75/995	35	91-174 657-91	35
91-173 538-15	48	91-173 882-05	50	91-174 618-05	35	91-174 659-71/995	35
91-173 539-15	48	91-173 883-91	50	91-174 619-05	35	91-174 662-05	35
91-173 541-15	50	91-173 885-15	50	91-174 620-71/995	34	91-174 663-92	35
91-173 545-91	48	91-173 886-05	10	91-174 621-15	35	91-174 665-75/995	35
91-173 546-05	48	91-173 894-91	50	91-174 622-05	35	91-174 666-15	35
91-173 553-05	50	91-173 902-91	48	91-174 623-91	34	91-174 667-05	34
91-173 556-72/951	48	91-173 906-24	25, 29	91-174 624-01	34	91-174 668-05	34
91-173 559-72/951	48	91-173 907-24	25, 29	91-174 626-05	34	91-174 669-75/995	34
91-173 562-05	48	91-173 910-72/951	41, 42, 45, 46	91-174 627-75/995	34	91-174 783-05	14
91-173 572-05	22, 24, 26, 28, 40, 42, 44, 46	91-173 911-05	40, 42, 44, 46	91-174 628-91	34	91-174 879-05	66
91-173 588-15	54	91-173 914-15	22, 24, 26, 28, 40, 42, 44, 46	91-174 629-05	34	91-174 934-05	34
91-173 589-15	54	91-173 915-92	22, 24, 26, 28, 40, 42, 44, 46	91-174 630-92	34	91-175 354-15	54
91-173 594-15	49	91-173 918-15	50	91-174 631-05	34	91-175 908-05	27, 29, 45, 47, 61
91-173 595-15	39	91-173 924-11	41, 42, 45, 46	91-174 632-05	34	91-176 052-25	25, 29
91-173 674-15	49	91-173 927-15	41, 42, 45, 46	91-174 633-05	34	91-176 062-15	65
91-173 676-15	10	91-173 929-05	41, 42, 45, 46	91-174 634-05	34	91-176 063-05	36
91-173 840-92	15	91-173 959-11	54	91-174 635-01	34	91-176 063-15	52, 54, 55, 56
91-173 841-01	15	91-173 972-05	22, 24, 25, 26, 28, 29, 40, 42, 43, 44, 46, 47			91-176 074-05	10
91-173 842-05	15					91-176 075-02	22, 24, 26, 28, 40, 42, 44, 46

No.	Seite Page Pages Página	No.	Seite Page Pages Página	No.	Seite Page Pages Página	No.	Seite Page Pages Página
91-176 076-91	41, 42, 45, 46	91-176 318-71/798	9	91-176 457-25	58	91-177 322-15	33
91-176 077-15	41, 42, 45, 46	91-176 319-05	9, 58	91-176 458-21	58	91-177 325-01	33
91-176 078-72/951	48	91-176 320-25	9	91-176 460-15	58	91-177 327-01	33
91-176 088-91	49	91-176 321-05	9, 58	91-176 461-21	58	91-177 330-05	33
91-176 089-05	49	91-176 322-05	9, 58	91-176 462-05	58	91-177 331-05	33
91-176 090-05	49	91-176 323-05	9, 58	91-176 463-05	58	91-177 334-01	32
91-176 091-05	49	91-176 324-25	9, 58	91-176 464-05	58	91-177 592-05	33
91-176 092-02	49	91-176 326-15	9, 58	91-176 465-05	58	91-177 933-05	33
91-176 093-05	50	91-176 327-25	9, 58	91-176 468-15	9, 58	91-178 010-15	32
91-176 094-05	50	91-176 329-05	9, 58	91-176 585-05	34	91-178 227-05	33
91-176 095-91	49	91-176 330-25	9, 58	91-176 587-05	34	91-178 659-12	31
91-176 096-15	49	91-176 331-15	9	91-176 589-05	34	91-186 644-91	61
91-176 097-91	50	91-176 332-25	9	91-176 604-05	34	91-186 647-05	61, 65
91-176 098-05	50	91-176 336-05	9, 58	91-176 624-01	35	91-186 657-05	61
91-176 103-91	48	91-176 350-91	15	91-176 625-05	35	91-186 658-15	63
91-176 147-05	34	91-176 351-12	14	91-176 626-05	35	91-186 659-15	63
91-176 204-05	11	91-176 352-05	9, 58	91-176 628-05	35	91-187 208-71/993	62
91-176 242-15	52, 55, 57	91-176 353-05	9	91-176 630-05	35	91-187 232-15	62
91-176 254-71/951	18	91-176 354-25	9, 58	91-176 633-15	35	91-187 292-05	62
91-176 255-04	18	91-176 355-25	9, 58	91-176 667-05	34	91-187 293-75/993	68
91-176 256-04	18	91-176 356-05	9, 58	91-176 721-02	33	91-187 438-15	62
91-176 257-05	18	91-176 373-21	9, 58	91-176 723-02	33	91-187 469-91	63
91-176 258-92	18	91-176 377-25	9, 58	91-176 730-15	33	91-187 470-93	62
91-176 259-05	18	91-176 378-05	9, 58	91-176 731-15	33	91-187 471-93	63
91-176 260-05	18	91-176 431-05	9	91-176 741-92	32	91-187 473-91	63
91-176 261-92	18	91-176 432-05	49	91-176 755-92	32	91-187 580-05	63
91-176 268-05	23, 25, 41, 43	91-176 434-72/951	48	91-176 756-05	32	91-187 581-91	63
91-176 289-05	23, 25, 41, 43	91-176 435-05	48	91-176 784-25	32	91-187 595-91	61
91-176 290-05	23, 25, 41, 43	91-176 436-71/951	48	91-176 793-75/995	32	91-290 001-91	39
91-176 302-05	9	91-176 437-71/951	48	91-176 794-12	32	91-290 138-91	37
91-176 315-05	9	91-176 447-15	30	91-176 806-12	32	91-290 139-91	37
		91-176 456-91	58	91-176 849-15	33	91-290 547-91	37

No.	Seite Page Pages Página	No.	Seite Page Pages Página	No.	Seite Page Pages Página	No.	Seite Page Pages Página
91-290 548-71/799	37	99-134 256-91	16, 56	99-136 602-91	52		
91-700 173-15	19	99-134 299-91	52, 63	99-136 707-91	16, 53, 54, 60		
91-700 249-15	50, 63	99-134 442-91	69	99-166 129-15	54		
91-700 412-25	9	99-134 546-91	69	280-1-120 144	5		
91-700 510-15	20, 22, 24, 26, 28, 40, 42, 44, 46	99-134 547-91	69	280-1-120 205	5		
91-700 689-05	36	99-134 548-91	69	280-1-120 243	5		
91-700 689-15	14, 19, 21, 36	99-134 621-01	63	280-1-120 247	5		
91-700 785-15	10	99-134 655-05	69	24 811-8.016-4	37		
91-700 798-15	18	99-135 001-95	53, 56	25 135-8.002-7	63		
91-701 515-15	48	99-135 029-91	59	25 308-2.006-0	69		
95-617 317-15	63	99-135 108-91	36	25 308-8.203-0	16, 52, 53, 54, 55, 56, 57, 59, 60, 61, 63		
96-700 216-15	13	99-135 233-91	61	25 308-8.204-0	16, 37, 56, 63, 65, 69		
96-720 441-15	35	99-135 444-91	36	26 536-3.030-9	34		
96-730 002-05	10	99-135 496-95	24, 28	26 536-3.040-9	34		
97-30 118-345	65	99-135 884-01	13				
97-30 189-655	65	99-135 891-91	54				
99-069 713-01	13, 18	99-135 911-91	63				
99-115 034-15	67	99-136 071-95	56				
99-115 037-45	67	99-136 072-95	56				
99-115 300-91	69	99-136 080-01	11				
99-115 411-91	69	99-136 089-01	13				
99-115 425-91	16, 52, 53, 54, 55, 56, 59, 60	99-136 235-91	53				
99-133 099-00	69	99-136 328-91	55, 56				
99-133 124-91	63	99-136 330-91	52, 55, 57				
99-133 125-91	63	99-136 336-95	70				
99-133 283-15	19	99-136 396-91	23, 24, 27, 28, 41, 42, 45, 46				
99-133 753-91	16, 52, 53, 54, 55, 56, 59, 60, 63	99-136 481-91	16				
99-133 920-91	63	99-136 482-91	53, 54, 60				
99-134 183-91	69	99-136 486-91	60				
99-134 206-05	65	99-136 489-91	68				
99-134 255-91	65	99-136 522-91	53				

PFAFF