

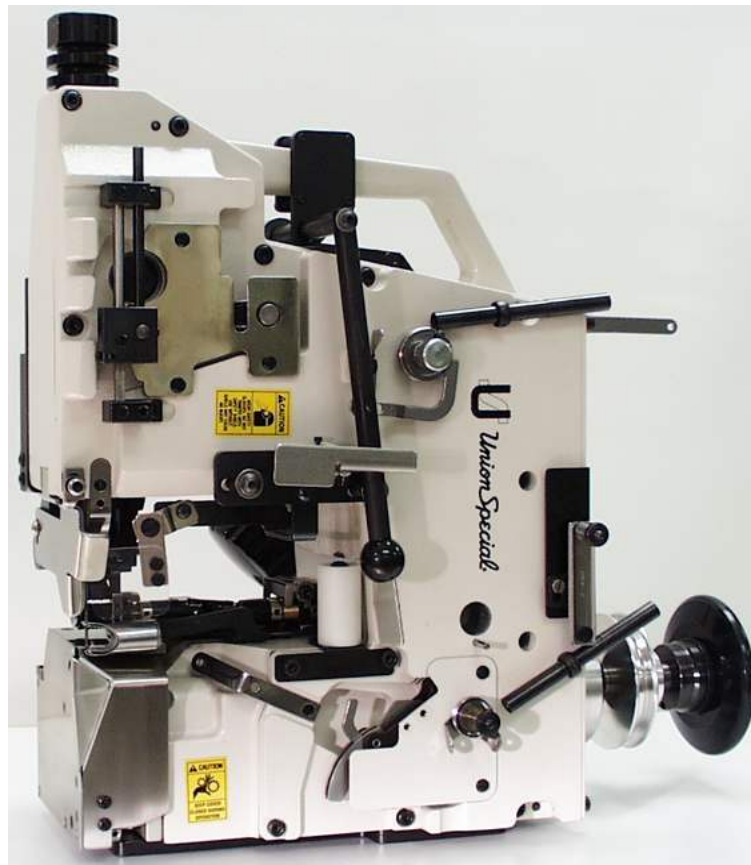

Union Special[®]
INDUSTRIAL SEWING EQUIPMENT

INSTRUCTIONS AND ILLUSTRATED PARTS MANUAL



MATTRESS TAPE EDGE MACHINE

**MANUAL NO. PT0603-GR
MT111T01-1**

03/05/09



MANUAL NO. PT0603-GR INSTRUCTIONS and ILLUSTRATED PARTS MANUAL for MT111 SERIES MACHINES

First Edition Copyright 2007
by
Union Special Machine Company
Rights Reserved in All Countries

PREFACE

This manual has been prepared to simplify ordering spare parts.

Views of various sections of the mechanism are shown so that the parts may be seen in their actual position in the sewing machine. On the page opposite the illustration will be found a listing of parts with their part numbers, descriptions and the number of pieces required in the particular view being shown.

Numbers in the first column are reference numbers only, and merely indicate the position of that part in the illustrations. Reference numbers should never be used in ordering parts. Always use the part number listed in the second column.

Component parts of subassemblies which can be furnished for repairs are indicated by indenting their description of the main subassembly.

This manual has been comprised on the basis of available information. Changes in design and / or improvements may incorporate a slight modification of configuration in illustrations or cautions.

On the following pages will be found illustrations and terminology used in describing the parts for your machine.

IMPORTANT: ON ALL ORDERS, PLEASE INCLUDE PART NUMBER, PART NAME AND STYLE OF MACHINE FOR WHICH PART IS ORDERED.

CONTENTS

PREFACE	2
SAFETY RULES	4
CAUTION AREAS	5
IDENTIFICATION OF MACHINES	6
STYLES OF MACHINES	6
NEEDLES	6
NEEDLE ORDERING	6
TORQUE REQUIREMENTS	6
THREADING THE MACHINE	7
INSERTING NEEDLE	8
STITCH FORMATION	8
TROUBLE SHOOTING	8
ADJUSTING THE STITCH LENGTH	9
LUBRICATION	10
OIL SPECIFICATION REQUIREMENTS	10
OIL FLOW DIAGRAM	12
NEEDLE / LOOPER SYNCHRONIZATION	14
UPPER ROLLER DRIVE PLATE ASSEMBLY	15
LOWER ROLLER SETTING	16
UPPER ROLLER AND PRESSER FOOT SETTING	16
PRESSER FOOT PRESSURE	16
NEEDLE BAR SETTING	17
LOOPER SETTING	17
NEEDLE GUARD SETTING	18
NEEDLE THREAD CONTROL	18
LOOPER THREAD CONTROL	19
BUSHINGS	21
NEEDLE BAR DRIVE	23
UPPER MAIN SHAFT	25
CRANKSHAFT ASSEMBLY	27
LOOPER DRIVE AND NEEDLE GUARD DRIVE	29
DRIVE PARTS AND THROAT PLATE SUPPORTS	31
PRESSER FOOT LIFT	33
OIL PUMP	35
OIL TUBES	37
OIL DISTRIBUTOR ASSEMBLY	39
NEEDLE THREAD CONTROL	41
LOOPER THREAD CONTROL	43
FRONT AND LOOPER COVERS	45
COVERS	47
BACK AND RIGHT COVERS	49
SEWING PARTS	51
ACCESSORIES	53
NUMERICAL INDEX OF PARTS	60
NUMERICAL INDEX OF PARTS	61

SAFETY RULES

1. Before putting the machine described in this manual into service, carefully read the instructions. The starting of each machine is only permitted after taking notice of the instructions and by qualified operators.
2. Observe the national safety rules valid for your country.
3. The sewing machine described in this instruction manual is prohibited from being put into service until it has been ascertained that the sewing units which these sewing machines will be built into, have conformed with the provisions of EC Machinery Directive 98/37/EC, Annex II B.

The machine is only allowed to be used as foreseen. The foreseen use of the particular machine is described in paragraph STYLE OF MACHINE of this instruction manual. Another use, going beyond the description, is not as foreseen.

4. All safety devices must be in position when the machine is ready for work or in operation. Operation of the machine without the appertaining safety devices is prohibited.
5. Wear safety glasses.
6. In case of machine conversions and all valid safety rules must be considered. Conversions and changes are made at your own risk.
7. The warning hints in the instructions are marked with one of these two symbols.

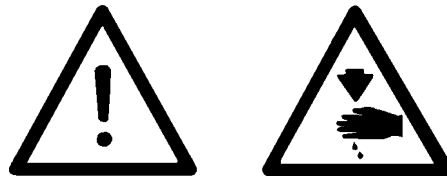

8. When doing the following the machine has to be disconnected from the power supply by turning off the main switch or by pulling out the main plug:
 - 8.1 When threading needle(s), looper, spreader, etc.
 - 8.2 When replacing any parts such as needle(s), presser foot, throat plate, looper, spreader, feed dog, needle guard, folder, fabric guide, etc.
 - 8.3 When leaving the workplace and when the work place is unattended.
 - 8.4 When maintaining the machine which has to be done regularly (see also **LUBRICATION**).
 - 8.5 When using clutch motors without actuation lock, wait until motor is totally stopped.
9. Maintenance, repair and conversion work (see item 8) must be done only by trained technicians or special skilled personnel under consideration of the instructions. Only genuine spare parts approved by Union Special have to be used for repairs.
10. Any work on the electrical equipment must be done by an electrician or under direction and supervision of special skilled personnel.
11. Work on parts and equipment under electrical power is not permitted. Permissible exceptions are described in the applicable section of standard sheet EN 50110 / VDE 0105.

CAUTION AREAS

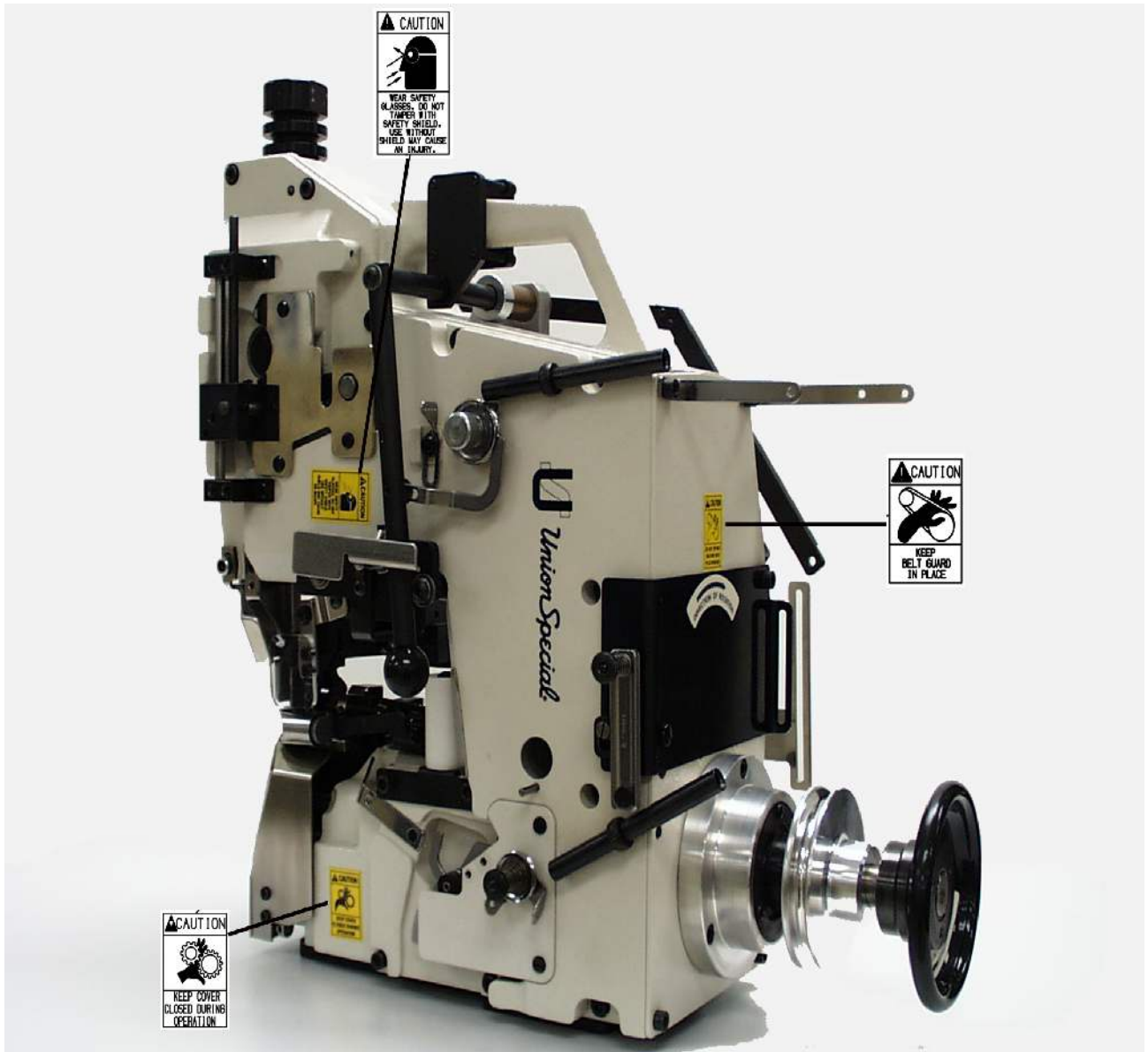

IDENTIFICATION OF MACHINES

Each UNION SPECIAL MT111 series machine is identified by a style number, which is stamped on the style plate located on the center portion at the rear of the casting. Serial number is also stamped.

STYLES OF MACHINES

High speed and high performance sewing machine for sewing tape edge binding on mattresses.

One needle, high throw, internal forced lubrication, with automobile type filter, totally enclosed looper mechanism, independently driven rear needle guard with no readjustment required when changing stitch length, and upper and lower driven feed rollers.

MT111T01-1: Sewing machine for sewing the mattress tape edge with a two thread double locked stitch.

Seam Specification:	401 BSA-1 (ASTM Std. D 6193)
Stitch Range:	4 to 9 SPI (6.3 – 12.5mm)
Standard Setting:	6 SPI (4.2mm)
Capacity beneath	
Upper Roller:	5/8 inch (15.9mm)
Maximum Speed:	up to 3100 stitches/minute
Weight Net:	41 kg

ASTM = American Society for Testing Materials

NEEDLES

Each needle has both a type and a size number. The type number denotes the kind of shank, point, length, groove, finish and other details. The size number, stamped on the needle shank, denotes the largest diameter of the blade measured midway between the shank and the eye. Collectively, the type and size number represent the complete symbol which is given on the label of all needles packed and sold by Union Special.

TYPE AND DESCRIPTION

794HSERV4—Round shank with flat, round point, single groove spotted, chromium plated. Size available: 180/073.

When changing the needle, make sure it is fully inserted in the needle head with the flat of the needle shank facing the screw, before the screw is tightened.

NEEDLE ORDERING

When ordering needles use the complete type and size numbers as printed on the package to ensure prompt and accurate processing of your order. A complete order should read as follows:

100 needles, type 794HSERV4, size 180/073

TORQUE REQUIREMENTS

Torque (measured in inch-pounds) is a "rotating" force in pounds applied through a distance by a lever (in inches or feet). This is accomplished by a wrench, screwdriver, etc. Many of these devices are available, which when set at the proper amount of torque will tighten the part to the correct amount and no tighter.

All straps and eccentric should be tightened to 26-28 inch pounds (3 - 3.2 Nm) unless otherwise noted.

Screws requiring a specific torque will be indicated on the illustrations.

THREADING THE MACHINE



Turn off main power switch before threading! When using clutch motors without actuation lock wait until motor has completely stopped.

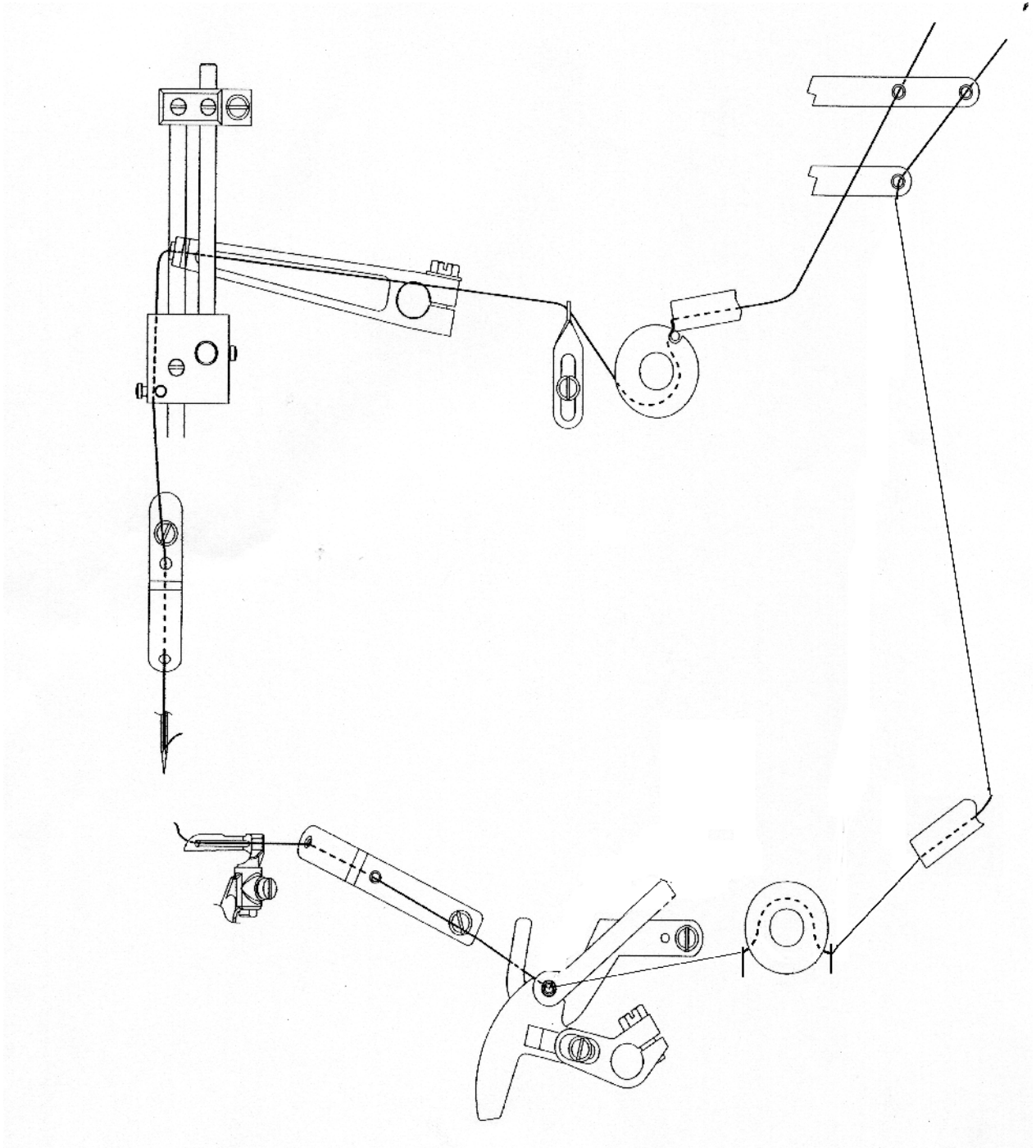

INSERTING NEEDLE

The standard needle is 794HSERV4-180/073. Insert needle according to the following procedure:

1. Bring needle head (A) to the highest position.
2. Loosen screw (B) Insert needle (C) into hole. The needle spot should face rearwards as viewed from the operator's side, with the tapered flat of the needle shank facing screw (B).
3. Retighten screw (B).

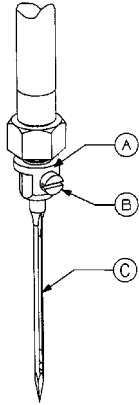

Turn off main switch on machine before replacing the needle!

STITCH FORMATION

1. Set the needle thread tension to pull the thread loop up near the bottom of the material with a consistent size for a uniform stitch.
2. Set the looper thread tension just tight enough to control the thread and prevent skipped stitches.
3. Set the needle thread strike-off so the support shaft extends a minimum of .500" (12.7mm) above its guide block.

TROUBLE SHOOTING

PROBLEM	CAUSE	SOLUTION
Broken threads while sewing	Threading between thread cone and sewing machine Looper tip blunt Needle tip blunt	Separate threads from any interference Stone off burr, or replace looper Replace needle
Malformed stitches	Thread not in thread tension assembly or correct eyelets	Follow threading diagram
Needle thread frays on bottom of sewn seam	Looper has sharp edge at retainer portion	Buff sharp edge slightly
Oil pressure gauge does not function during operation	Line filters are filled with foreign material	Replace built-in line filters

ADJUSTING THE STITCH LENGTH

1. Remove plug (A).
2. Turn handwheel until center adjustment screw is located.
3. Turn adjustment screw clockwise to lengthen stitch length.
4. Turn adjustment screw counterclockwise to shorten stitch length.
5. Replace plug (A) after adjustment is made.

NOTE: Needle guard requires no readjustment when stitch length is changed.

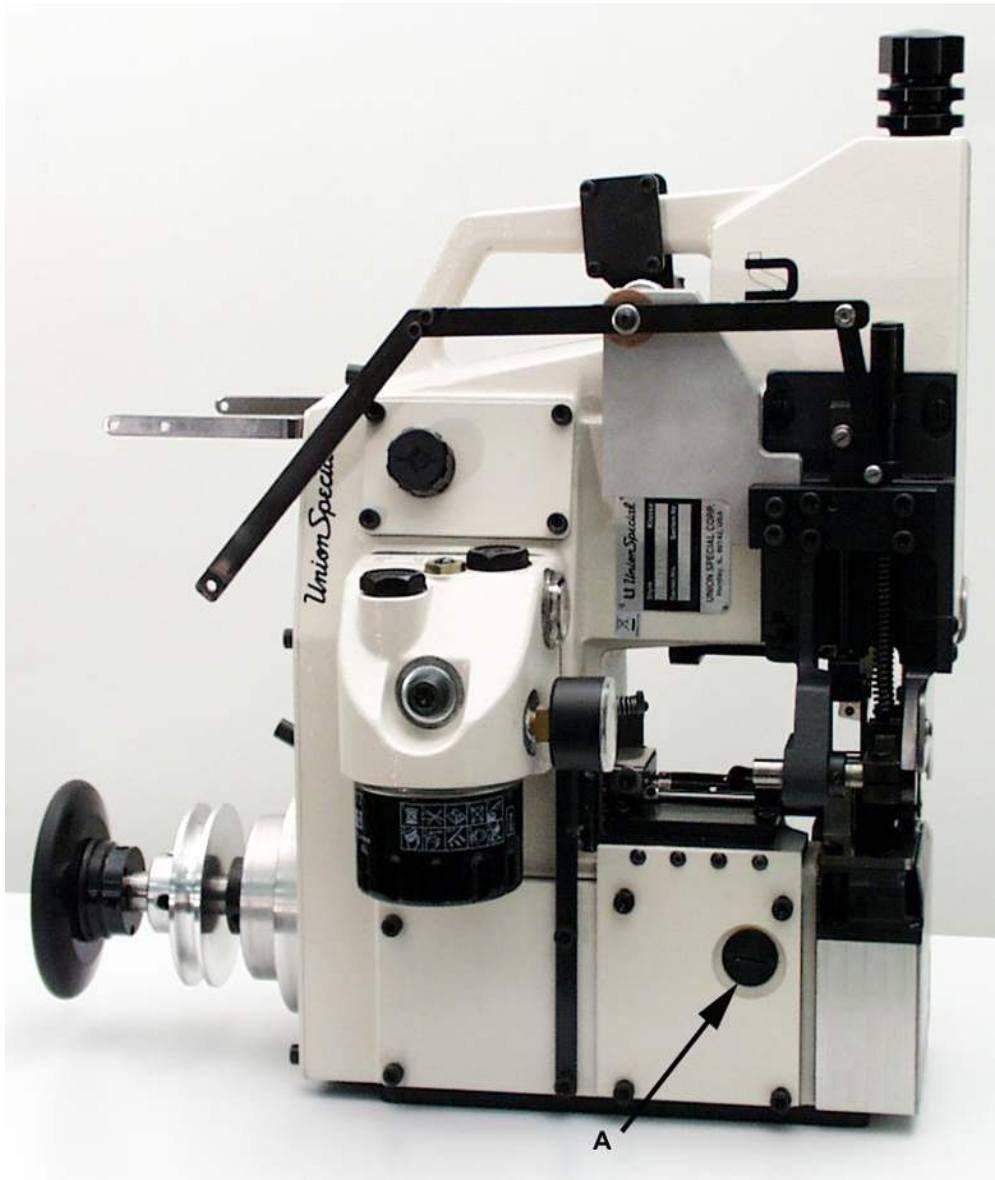

Turn off main power before setting stitch length!
When using clutch motors without actuation lock wait until the motor has completely stopped.

LUBRICATION

CAUTION! Oil has been drained from machine before shipping and the reservoir must be filled before beginning to operate. Use the oil with UNION SPECIAL Specification No. 175 which is delivered with the accessories of the machine. This oil is equivalent to a hydraulic oil according to ISO VG 22 and **can be purchased from UNION SPECIAL in 0.5 liter containers under part No. 28604R, or in 5 liter containers under part No. 28604V.**

ADDING OIL THE FIRST TIME, AND WHEN OIL AND FILTER ARE CHANGED:

1. Remove 26mm oil fill screw (A) nearest oil level indicator (B) and 26mm oil filter fill screw (C) above oil filter. Fill oil in filter, and then lock screw (C).
2. Add oil in the oil hole until oil registers in the oil level indicator (B).
3. **Run machine and add oil until oil line is at the center dot of the oil level indicator (B). The oil capacity of the machine with the filter is 0.5 liters (18.0 ounces).**
4. Screw oil fill screw (A) back on and tighten.
5. The oil pressure gauge (D) should register 15 PSI (1 bar) while the machine is running.
6. The oil pressure and oil level should remain as above while the machine is in operation.
7. If the oil pressure registers more than 15 PSI (1 bar) loosen nut (E) and turn screw (F) counterclockwise to reduce the oil pressure.
8. Retighten nut (E).

NOTE: If the machine has not been used in a while, the oil level will take about 30 seconds of machine running time to raise to the center level, and the oil pressure to register at the normal pressure. Follow this same procedure after changing oil and filter.

NOTE: If during operation no oil pressure is indicated on the oil pressure gauge (D), shut off the machine and check the oil lines to make sure they are not bent improperly to reduce oil flow or if there is an obstruction in the oil line or oil siphon filters.

CHANGING THE OIL AND FILTER:

1. **Oil and oil filter (G) should be replaced after the first 200 hours of operation. Thereafter oil and filters must be changed every 500 hours of operation.**
2. **Use Union Special Spec. 175 or equivalent.**
3. There are two 5mm Allen head oil drain plug screws used to drain the oil from the machine. Plug screw (H), located on the underside of the reservoir next to the filter, is used to drain the oil from the oil pump and filter and screw (J), located just below the looper and needle guard shaft is used to drain the oil from the machine head.
4. Loosen screw (J) first and oil fill screw (A) to drain the oil from the head.
5. Loosen screw (H) next and drain the oil from the pump and filter.
6. Replace and tighten both screws (J) and (H) and retighten oil fill screw (A)
7. Remove oil filter and replace with new one.

OIL SPECIFICATION REQUIREMENTS

All oils shall be non-compounded, straight mineral oils, of high viscosity index (will not thin down excessively with heat). Practically all oil companies have Union Special Specification 175 and their industrial representatives will make their recommendations conforming to Union Special requirements.

UNION SPECIAL SPEC. 175

Nominal Viscosity 100 S.S.U at 100°F (Nominally ISO Grade 22).

Viscosity at 100°F	90 - 125 S.U.S (22 cSt)
Flash Point (min.)	350°F (176°C)
Pour Point (max.)	20°F (- 7°C)
Color (max.)	1
Neutralization No. (max.)	0.10
Viscosity Index (D&D min.)	90
Copper Corrosion (max.)	1A
Aniline Point	175 - 225°F (79 - 107°C)
Compounding	Not a requirement

NOTE: The use of non-corrosive oxidation, rust and foam inhibitors and / or film strength and lubricity enhancers is permitted, but these additives must be completely soluble in the oil, they must not separate, nor be removed by wick feeding.

Corrosive “EP” (extreme pressure), tackiness/adhesive, lead soap and detergent additives are not permitted, nor are solid lubricants like graphite, PTFE, etc.

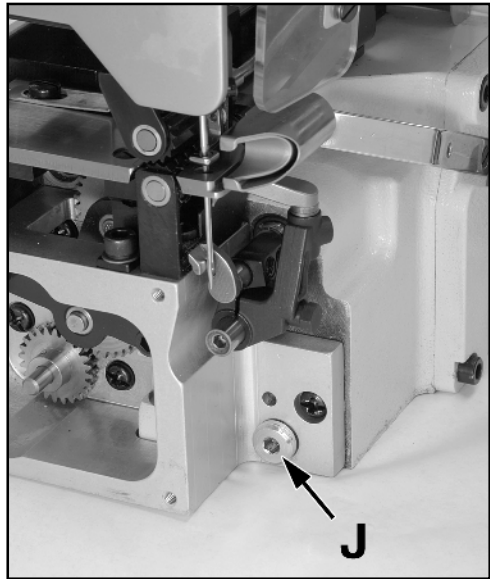
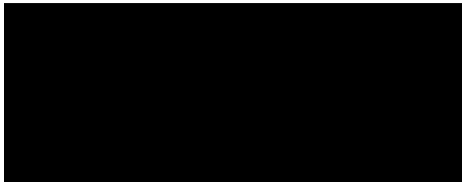
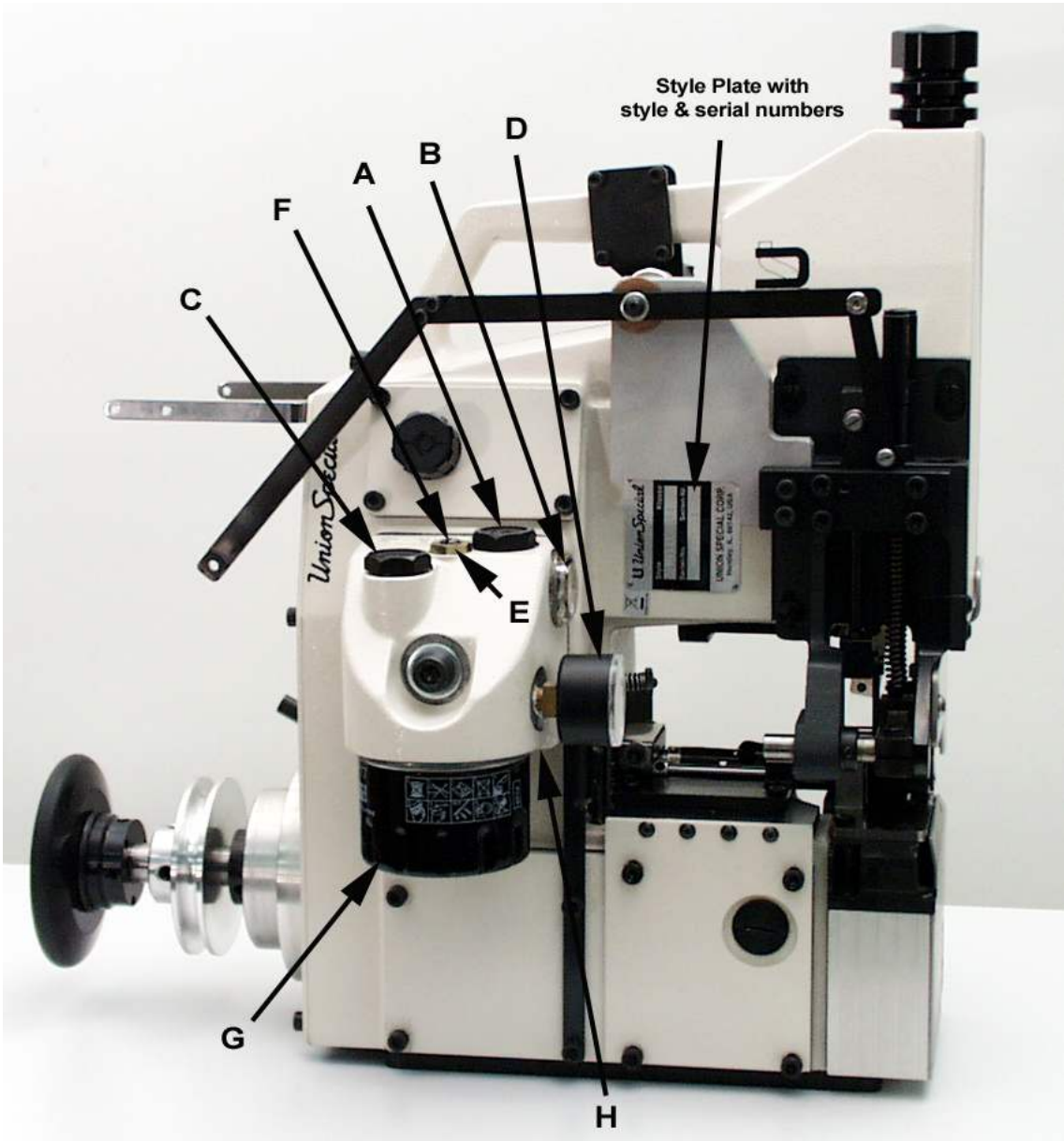

OIL FLOW DIAGRAM

The oiling system consists of pressurized oil 1 bar (15 PSI) through oil distributor (A) to three bearing areas (B), (C), (D). From there, the oil is sent to strategic areas where oiling is necessary. First, the oil flows from the oil chamber (L) through the check valve (E) into the 3.5mm portion of the gerotor in the oil pump (F), through the main oil distribution pipe (I) in the oil housing (M) through the oil filter media (J), into the center of the oil filter (K), and out into the oil distributor (A) to the three bearing areas. The check valve (E) provides security to prevent oil from draining back into the sewing machine when the machine is idle.

There are two oil returns (H,G):

One return (G) is located in the lowest part of the feed area while the other return (H) is located in the lowest part of the needle drive area. The oil in these areas is returned to the oil chamber (L) by suction through the gerotor oil pump (F). The oil is ensured to stay in the oil chamber (L) by passing through an oil overflow tube (N) located in the oil chamber (L). The tube opening is above the oil line so oil will not return to the feed drive and needle drive areas.

There is also an oil siphon filter (O) attached to each return line to ensure filtered oil at all times.

NOTE: If oil pressure gauge does not function, make sure oil return lines and line filters (O) are not filled with foreign material preventing the oil to return. Check also to ensure that there is at least .060" (1.5 mm) gap between the end of the return tube and the casting for the upper tube (H) and the feed cover for lower tube (G).

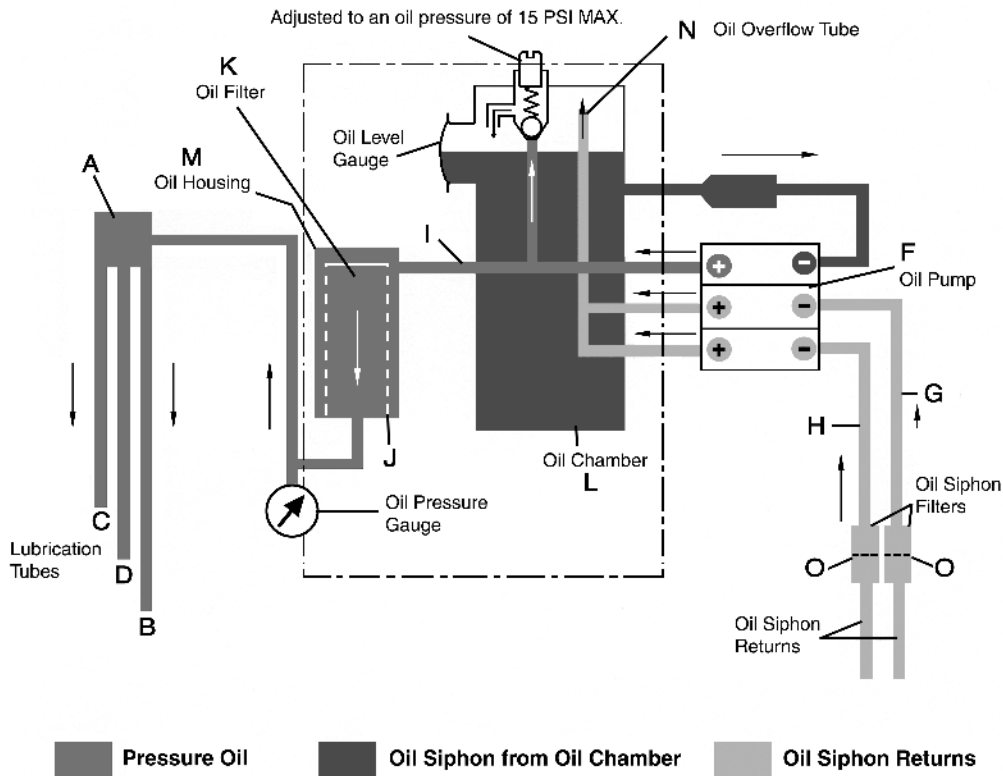

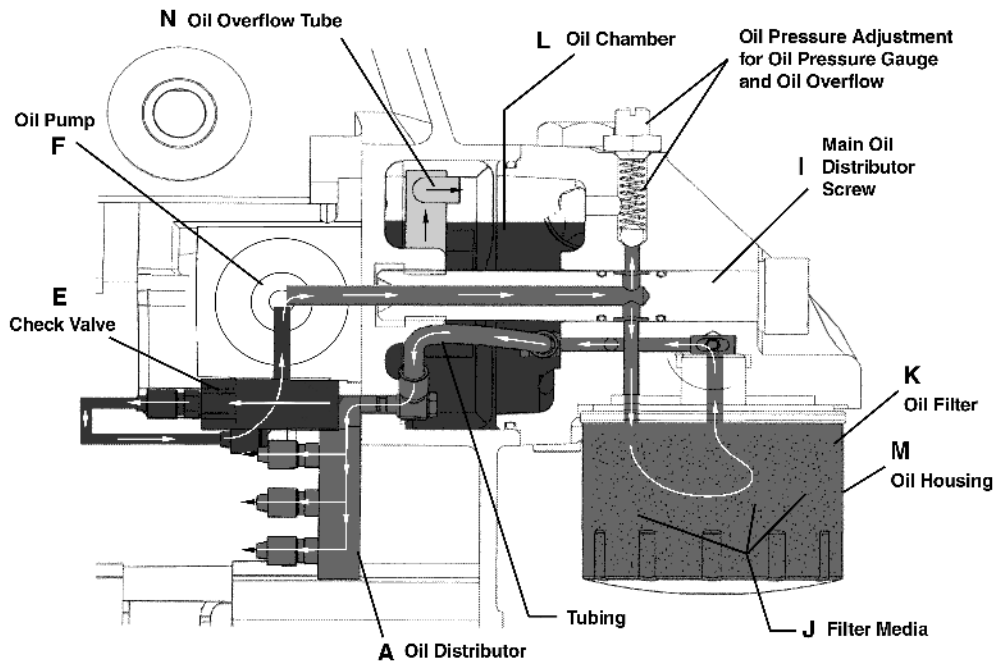
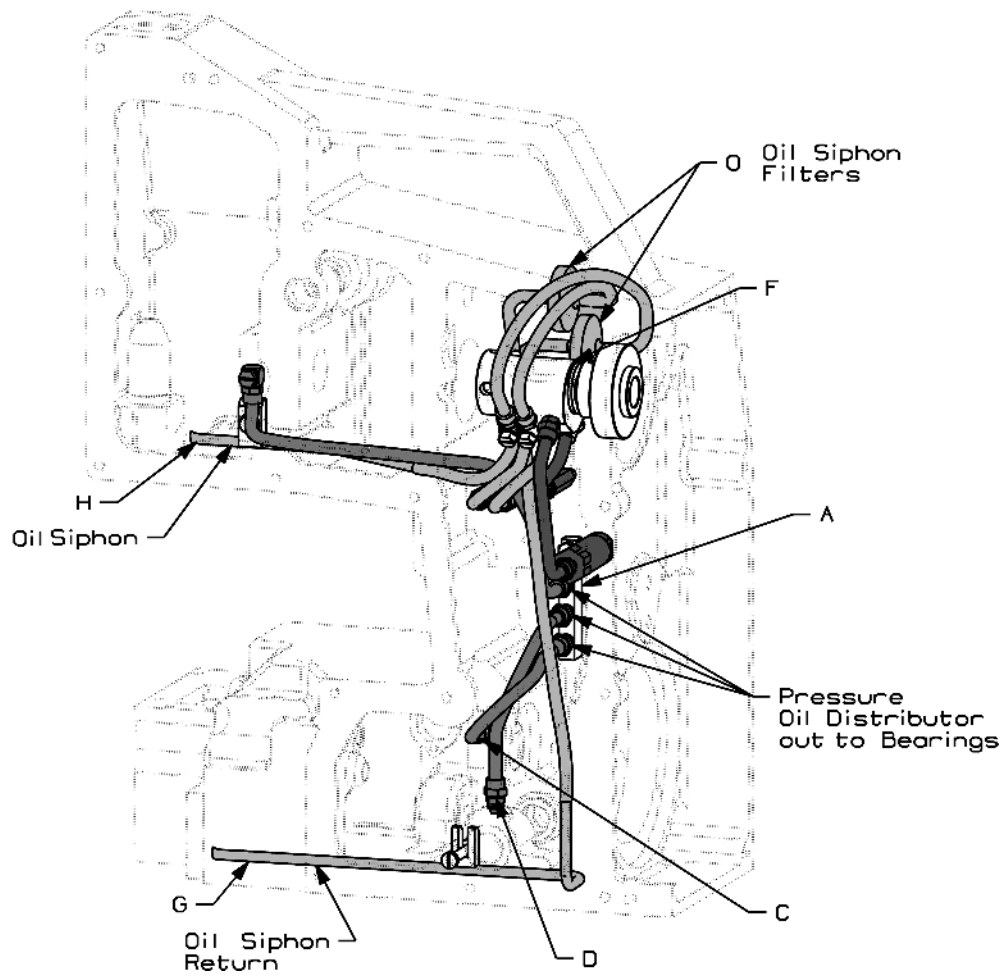

NEEDLE / LOOPER SYNCHRONIZATION

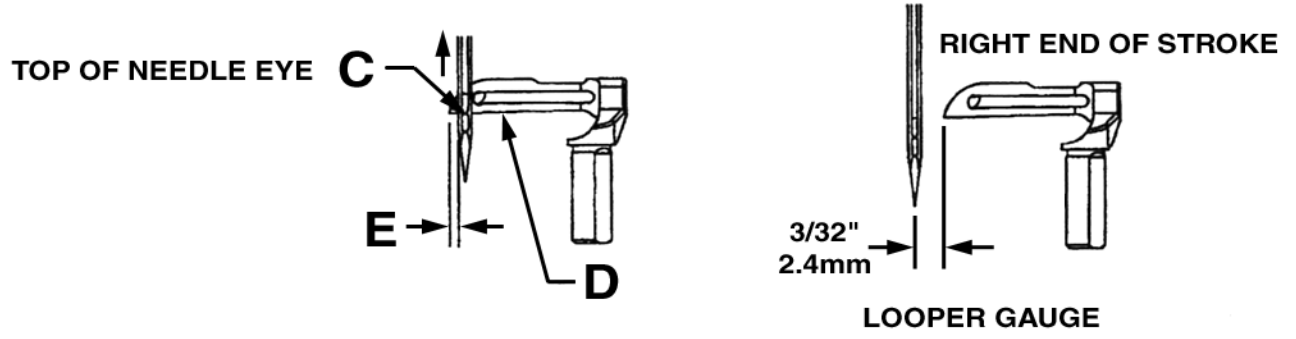

TT148
SYNCHRONIZING GAUGE
KIT

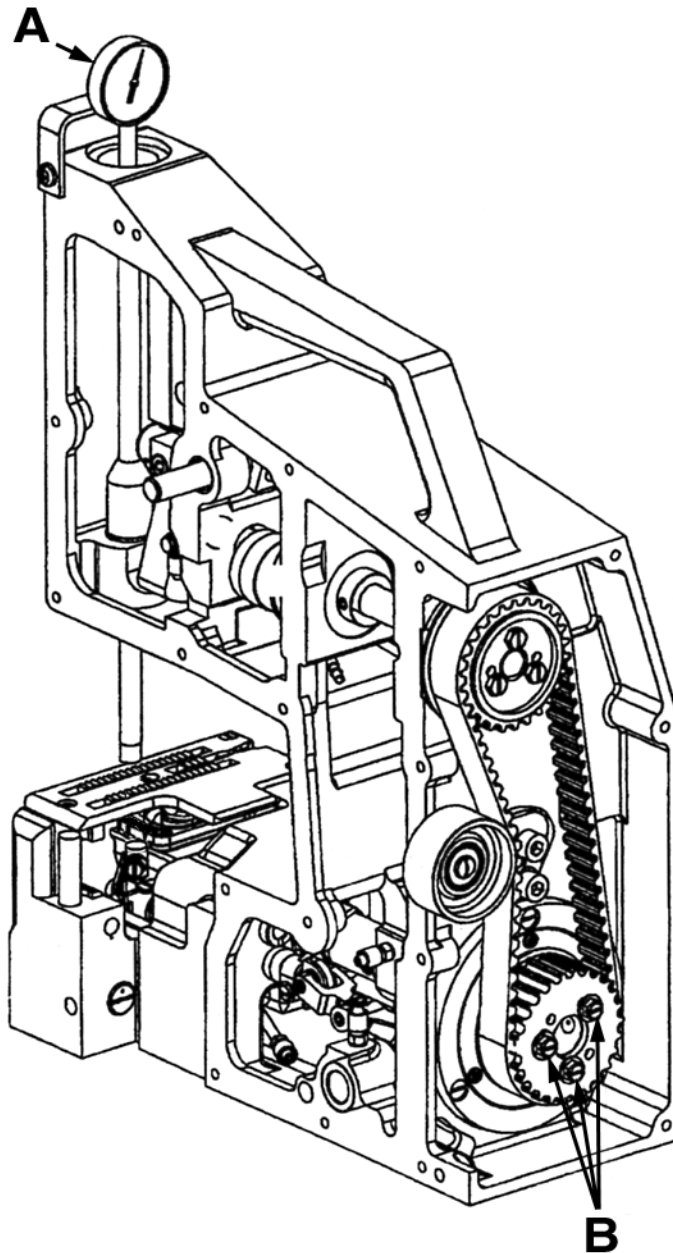

1. Synchronize with TT148 Synchronization Gauge Kit

Turn handwheel in clockwise direction until looper shaft is approximately $\frac{1}{4}$ " from the inside of the end cover. Loosen the looper holder and move the holder to the left until its left edge touches the end cover and lock in place with its screw.

Turn handwheel until the needle is at the bottom of the stroke and the looper holder is at the farthest position right.

Install the dial indicator (A) on the top of the machine. Set the indicator dial to zero.

Turn the handwheel clockwise until the looper holder touches the end cover. Record the number of revolutions and final indicator reading.

Turn the handwheel counterclockwise until the looper holder touches the end cover once again. Record the number of revolutions and final indicator reading. The readings should be the same as above.

The indicator must travel the same distance in the counterclockwise direction, a tolerance of $\pm .010$ " (.25mm) is acceptable.

If the indicator is not the same distance, adjustment can be made by loosening the 3 screws (B) in lower belt sprocket 10042, and moving slotted sprocket accordingly. If there is a lower number reading of the indicator on the front travel, turn the slotted sprocket counterclockwise. If there is a lower number reading of the indicator at the looper rear travel, turn the slotted sprocket clockwise.

After correct adjustment tighten the 3 screws (B) to 100 in lbs. (11.5nm)

Loosen the looper holder and return to its original position.

2. Synchronize without TT148 Synchronization Gauge Kit

If no indicator is available, set the synchronization measuring with a slide caliper or steel ruler.

Set the looper gauge to $\frac{3}{32}$ " (2.4mm).

Check the synchronization by moving the looper rearward behind the needle scarf. Continue moving the looper to the left so that the top of the needle eye (C) is flush with the bottom of the looper blade (D). Measure the distance from the looper tip to the left side of the needle (E).

Move the looper in the opposite direction to where the looper is in front of the needle. Set the top of the needle eye (C) flush with the looper blade (D), the same as above. Measure the looper point to the left side of the needle. The second measurement should be approximately $\frac{1}{64}$ " (0.4mm) **less** than the first (E).

If the measurement with the looper in front of the needle is less than the rear, turn the slotted sprocket counterclockwise. If the measurement is less with the looper behind the scarf of the needle, turn the slotted sprocket clockwise.

Tighten the three screws (B) to 100 in. lbs. (11.5Nm).

UPPER ROLLER DRIVE PLATE ASSEMBLY

The plate assembly is set up and down and front to back so that the feed roller gear (A) on the end of the shaft engages with the feed drive gear (B) in the lower roller housing without binds. The centerline of the feed roller gear (A) on the drive plate assembly is set to the rear of the centerline of the feed drive gear (B) in the lower roller housing. A good starting position is to set the distance from the back side of the back cover to the back of the adjustable plate at $1\frac{1}{4}$ " and parallel to the back cover. To make this adjustment, loosen the (4) roller shaft housing screws (C) and move the housing as required, then tighten the (4) screws securely.

After the front to back is set the height must be set so that the gears engage with no binds and with a small amount of play. This adjustment is made by loosening the (4) back cover screws (D) and raising or lowering the plate as needed. A 10-32 thread screw can be used in the threaded hole of the roller drive plate base to make adjustment easier. Recheck the play in the gears after the screws are tightened to ensure the setting is correct.

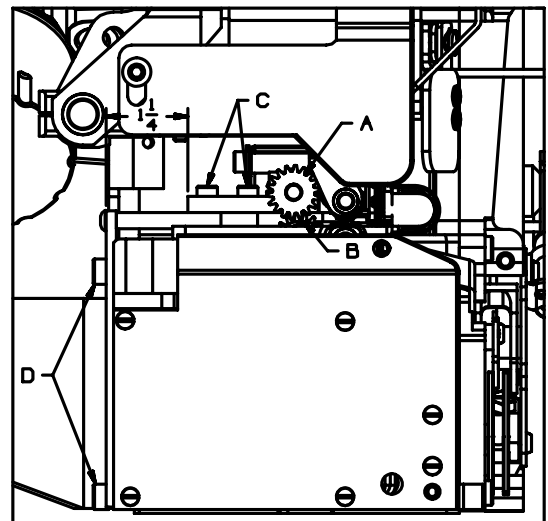

LOWER ROLLER SETTING

The lower roller should be set left to right so the grooves in the roller align with the guide wires in the throat plate when it is against the left bushing in the roller support. Moving the roller support left or right as needed then tightening the two screws (A) for the roller support make this adjustment. The roller is thrust to the left against the bushing in the support while the drive gear is thrust against the thrust washer and bushing in the right side of the support. There should be no shake or bind in the roller after this adjustment is made.

Note: Keep front edge of roller support parallel with top edge of casting.

Note: When making this adjustment maintain play in gears.

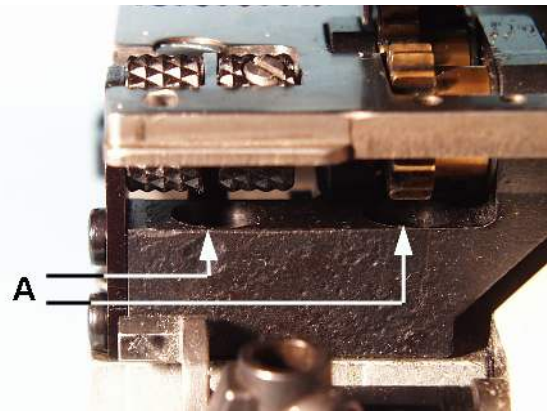

UPPER ROLLER AND PRESSER FOOT SETTING

1. Align the upper roller left to right so that it is parallel to the lower roller; at this time the presser foot will also be approximately centered to the needle. Set the roller front to back so the when the roller is raised to its highest position it does not hit the back of the needle. This position is generally slightly to the rear of the lower roller. Tighten the binder screw in the upper roller shank to secure this position.
2. The presser foot is set with the upper roller in its lowest position. The front to back position is set so that the needle is centered in the radius of the presser foot slot. The height of the presser foot is set so that there is 0.125" - 0.130" (3.18mm - 3.30mm) between the bottom of the presser foot and the top of the throat plate. When this adjustment is made Loctite 222 screw lock must be applied to the threads of the screws holding the presser foot to the presser foot shank.

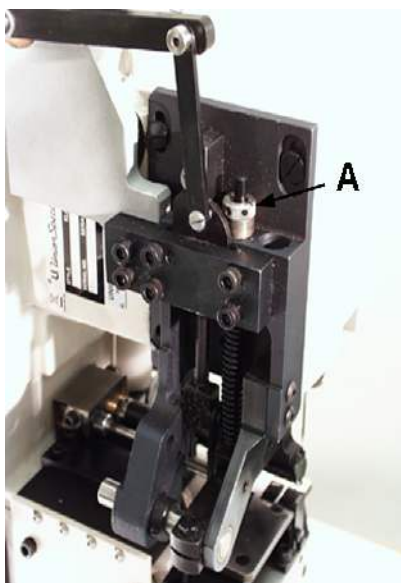
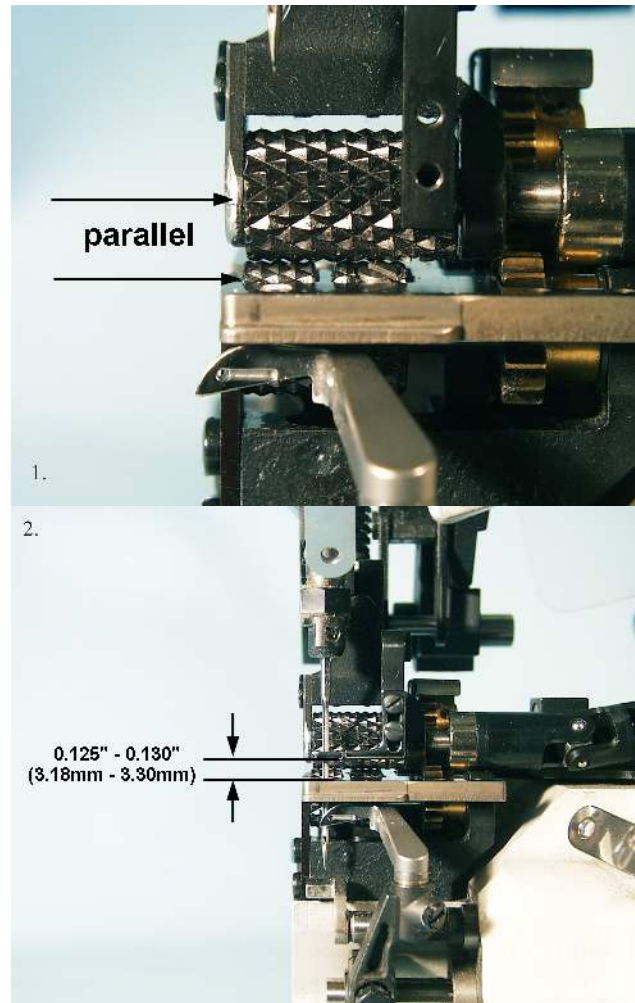

PRESSER FOOT PRESSURE

Turning presser foot presser adjustment screw (A) clockwise increases the pressure, while counter clockwise decreases the pressure. Set required force at 16 to 17 lbs. (75 N).

NEEDLE BAR SETTING

The needle holder must be set with its locking screw at a 60° angle to the right of center when viewed from the front of the machine. Set the needle bar height so that when the needle is at top dead center in its travel, the distance from the tip of the needle to the top of the throat plate is .875" (22.2mm) ± .020" (0.5mm). This adjustment is made by loosening screw (A) inside the needle bar access hole (circled).

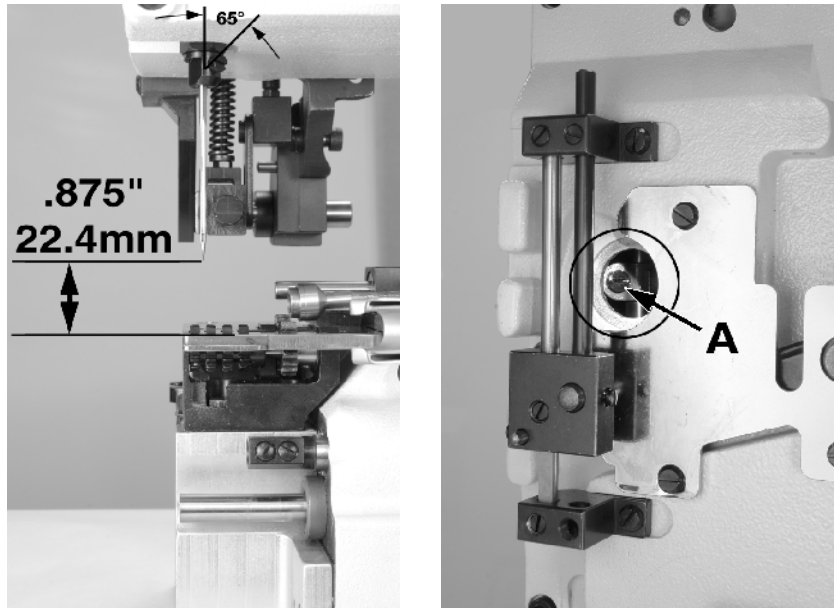

LOOPER SETTING

Set the looper so the point is 3/32" (.094", 2.4mm) from the centerline of the needle, when the looper is at its furthest position to the right. Looper gauge number 21225-3/32 is available for setting the looper. While maintaining the 3/32" (.094", 2.4mm) looper gauge set the looper front to back so the tip of the looper touches the scarf of the needle without deflecting the needle. For adjustment, loosen screw (B) in the looper holder and move forward or backward as required. Retighten the screw (B) in the looper holder and recheck the settings.

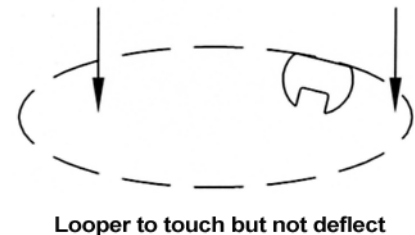
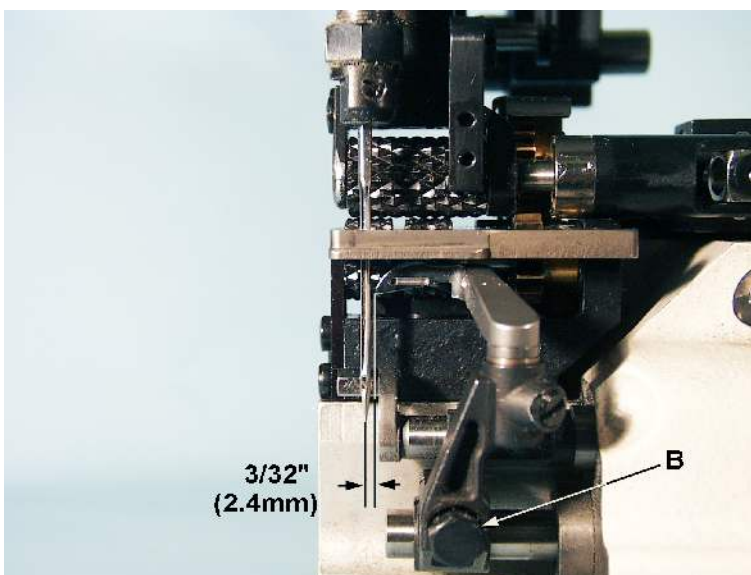

Note: If needle and looper settings are incorrect skipping may occur.

NEEDLE GUARD SETTING

1. Slip shaft of guard onto holder.
2. Position the guard about central in the clearance of the rubber sealing frame.
3. Position the guard so the guard shank clears the right side of the needle. Allow .040" to .080" (1 to 2 mm) so if the largest diameter needle is ever used, it will clear.
4. Rotate adjustable pulley to bring the tip of the looper close to the right side of the needle, then push the guard to just contact the needle and not deflec it. Tighten the guard with one screw. Rotate adjustable pulley in direction of arrow to check this setting. If correct, tighten both screws very tight (will not have to be reset when changing stitch length).

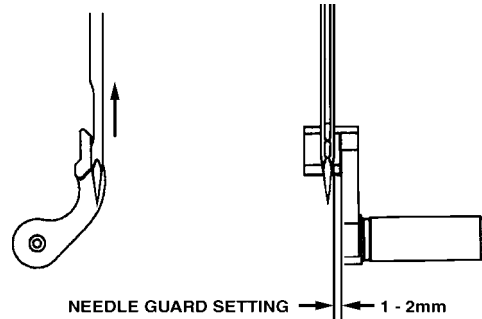

NEEDLE THREAD CONTROL & TENSION

1. Needle thread take-up lever is set up and down to be 1 1/8" (28mm) from the center of the thread lever eyelet hole to the underside of the top needle thread strike-off bracket at the top of its stroke. The lever is also set front to back to clear the back of the thread guide by .040" (1mm).
2. Set the needle thread strike-off to 1 1/8" (28mm) between the bottom of the strike-off and the top of the strike-off support bracket.
3. Set the needle thread eyelet directly to the left of the needle thread tension assembly to the bottom of its slot.
4. Set the needle thread tension to be heavy enough to pull up a good stitch without skipping.

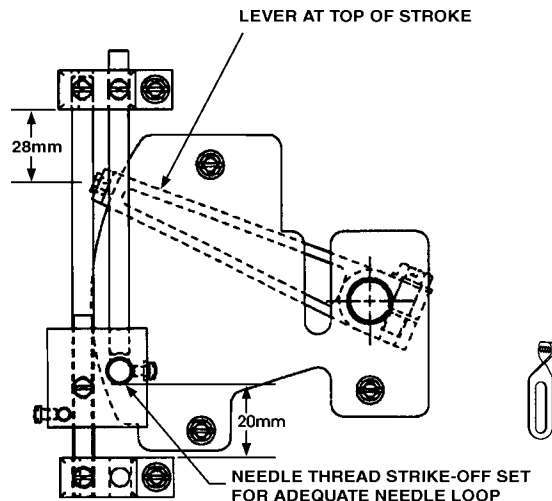

LOOPER THREAD CONTROL & TENSION

1. Set the cast-off edge of the take-up to be 1.97" (50mm) from the centerline of the looper take-up shaft.
2. Set the edge of the take-up to be .472" (12mm) to .512" (13mm) from the bottom of the outer cover when the take-up is at the end of its stroke.
3. At the same take-up position the distance from the centerline of the take-up eyelet hole to the edge of the take-up should be .020" (0.5mm) to .059" (1.5mm).
4. Set the centerline of the take-up eyelet hole to be 1.89" (48mm) from the outside of the looper thread take-up shaft.
5. Set looper thread tension as light as possible yet still control the looper thread.

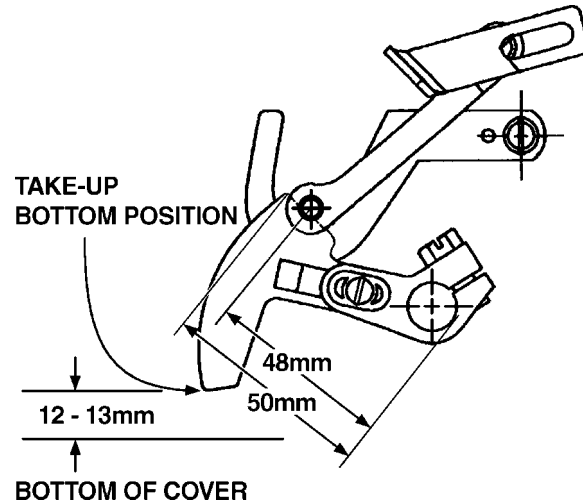

LOOPER THREAD TAKE-UP SETTING

The looper thread should cast-off at the high point of the cam when the tip of the needle is 0.0 to 0.040" (0 to 1mm) below the bottom of the looper blade.

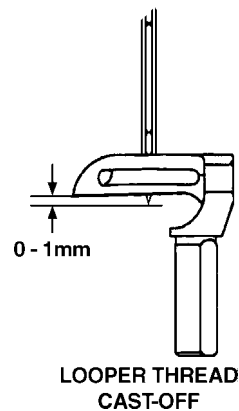

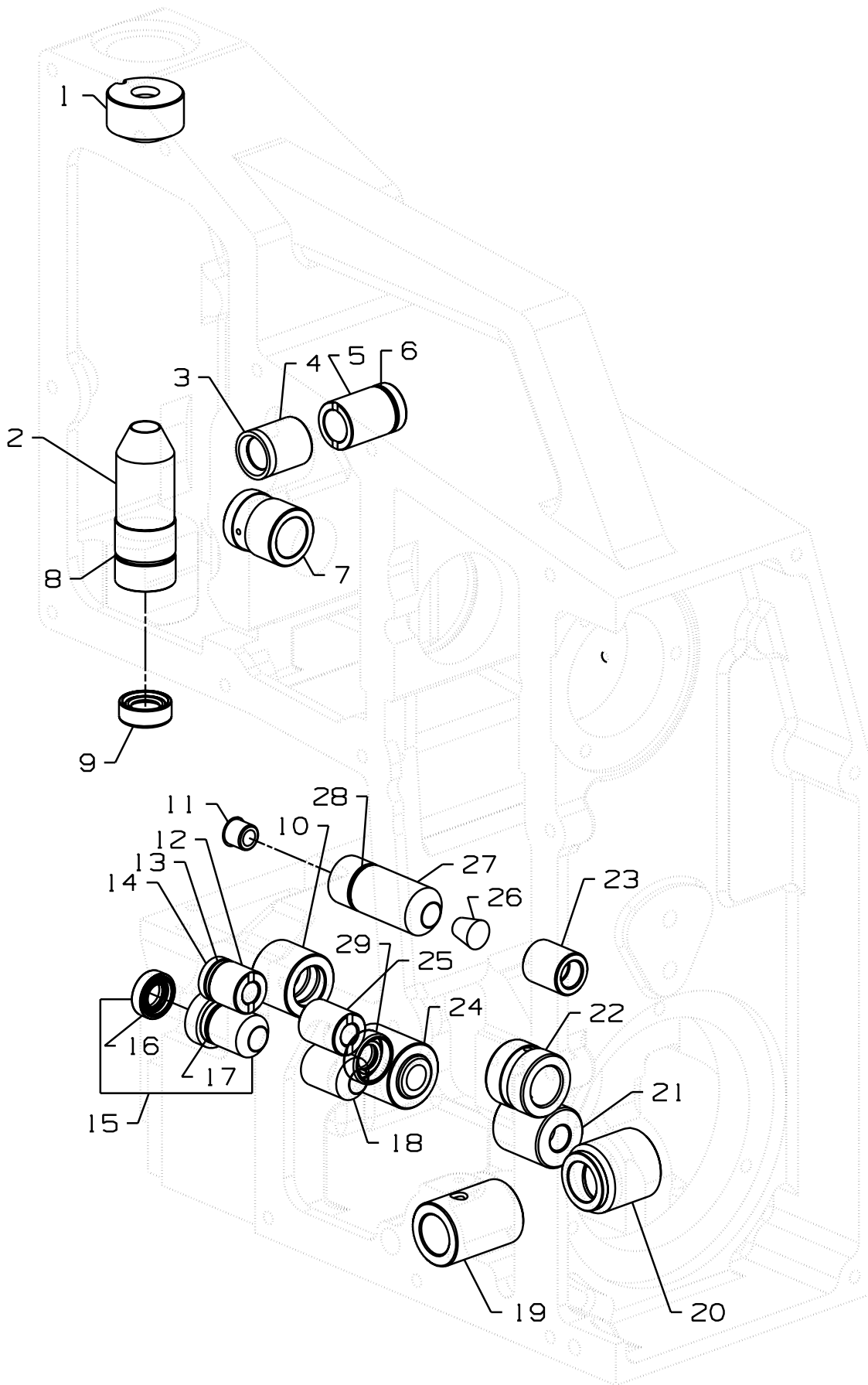

BUSHINGS

Ref. No.	Part No.	Description	Amt. Req.
*1.	10044AL	Bushing, needle bar, upper	1
*2.	10054B	Bushing, needle bar, lower	1
3.	660-1033	Lip Seal	1
*4.	10044CGL	Bushing, needle thread control	1
*5.	10044DGL	Bushing, needle thread control	1
6.	660-1138	"O" Ring, for 10044DGL	1
*7.	10044XGL	Bushing, main shaft	1
8.	660-1137	"O" Ring, for 10054AB	1
9.	660-1085	Lip Seal	1
10.	10044BK	Bushing	1
11.	TA0950806R0	Plug	1
12.	10044AV	Bushing, needle guard	1
13.	660-1021	Washer, thrust	1
14.	660-1032	Lip Seal	1
15.	G10044T	Bushing, looper drive	1
16.	999-256F	Lip Seal	1
17.	660-1018	"O" Ring, for G10044T	1
18.	10044AU	Bushing, looper drive	1
*19.	10044SGL	Bushing, looper drive cross shaft	1
20.	10044AH	Bushing	1
*21.	10044BH	Bushing	1
*22.	10044GGL	Bushing, crank shaft	1
*23.	10044PGL	Bushing, knife drive	1
*24.	10044BJ	Bushing	1
25.	10044AW	Bushing, needle guard	1
26.	CO66	Plug	1
*27.	10044GL	Bushing, knife drive	1
28.	660-1138	"O" Ring, for 10044GL	1
29.	999-256G	Lip Seal	1

* Secured with Loctite # 680

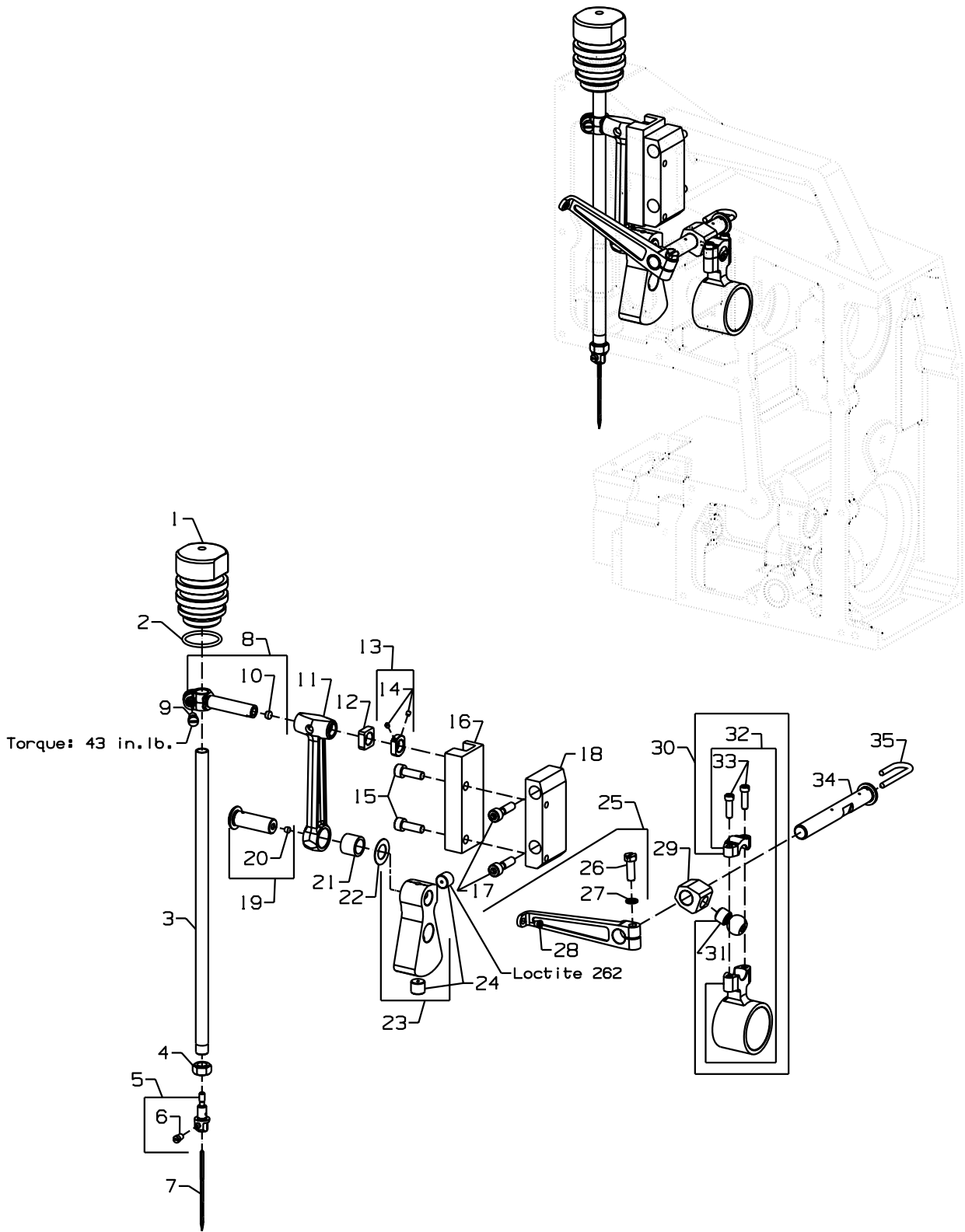

NEEDLE BAR DRIVE

Ref. No.	Part No.	Description	Amt. Req.
1.	10096	Guard, needle bar	1
2.	660-1141	"O"Ring, for 10096	1
3.	10017	Needle Bar	1
4.	10095F	Nut, hex	1
5.	10018B	Needle Head	1
6.	SS6110650TP	Screw	1
7.	794HSERV4-180/073	Needle	1
8.	10016B	Needle Bar Connection	1
9.	SS6150810SP	Screw	1
*10.	----	Plug	1
11.	10045N	Connecting Rod, needle drive	1
12.	10038A	Block, slide	1
13.	10033H	Collar, needle bar connection	1
14.	SS8080410TP	Screw	2
15.	SS6151812TP	Screw	2
16.	10037	Guide, needle drive	1
17.	SS6152212SP	Screw	2
18.	10083	Bracket, needle drive guide	1
19.	10047B	Crank Pin, needle drive	1
*20.	----	Plug	1
21.	660-1037	Bearing, caged needle	1
22.	660-1059	Washer	1
23.	10091	Counterweight, needle drive	1
24.	22894AV	Screw, set	2
25.	10048A	Lever, needle thread	1
26.	SS9151740CP	Screw	1
27.	WP0651001SB	Washer	1
28.	B1124804000	Eyelet, thread	1
29.	10016A	Connection	1
30.	29126FP	Bearing Assembly	1
*31.	----	Screw, ball	1
*32.	----	Bearing, ball joint	1
33.	SS6121610TP	Screw	2
34.	10022G	Shaft, needle bar connection	1
35.	CL21	Wick	1

*NOTE: Not sold separately

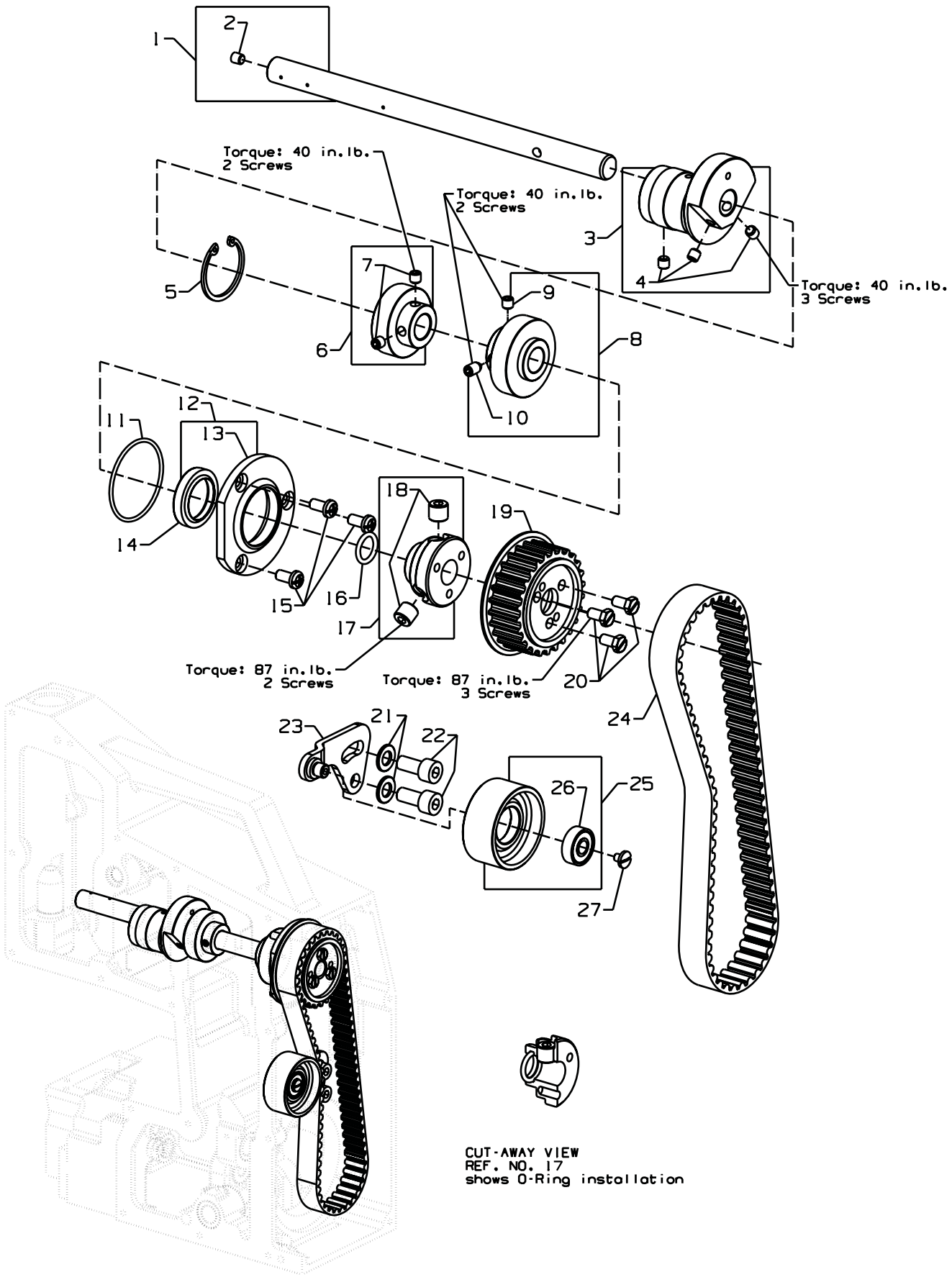

UPPER MAIN SHAFT

Ref. No.	Part No.	Description	Amt. Req.
1.	10022F	Main Shaft, upper	1
2.	TA0370601M0	Plug	1
3.	10040B	Eccentric	1
4.	SS8660612TP	Screw, set	3
5.	660-1029	Ring, retaining	1
6.	29476ZS	Bearing Assembly	1
7.	SS8660612TP	Screw, set	2
8.	10033M	Sprocket, belt	1
9.	SS8660612TP	Screw, set	1
10.	SS8661212TP	Screw, set	1
11.	660-1147	"O" Ring	1
12.	10042K	Flange Assembly	1
13.	10042F	Flange	1
14.	660-1103	Lip Seal	1
15.	SS4151215SP	Screw	3
16.	660-212	"O" Ring	1
17.	10021D	Hub	1
18.	22894AV	Screw, set	2
19.	10021E	Pulley, belt	1
20.	SS9151120CP	Screw	3
21.	95953	Washer	2
22.	SM6081802TP	Screw	2
23.	10067	Lever, belt tension	1
24.	10042J	Belt, timing	1
25.	10076	Roller, tension	1
26.	660-1041	Bearing, ball	1
27.	SS7110570SP	Screw	1

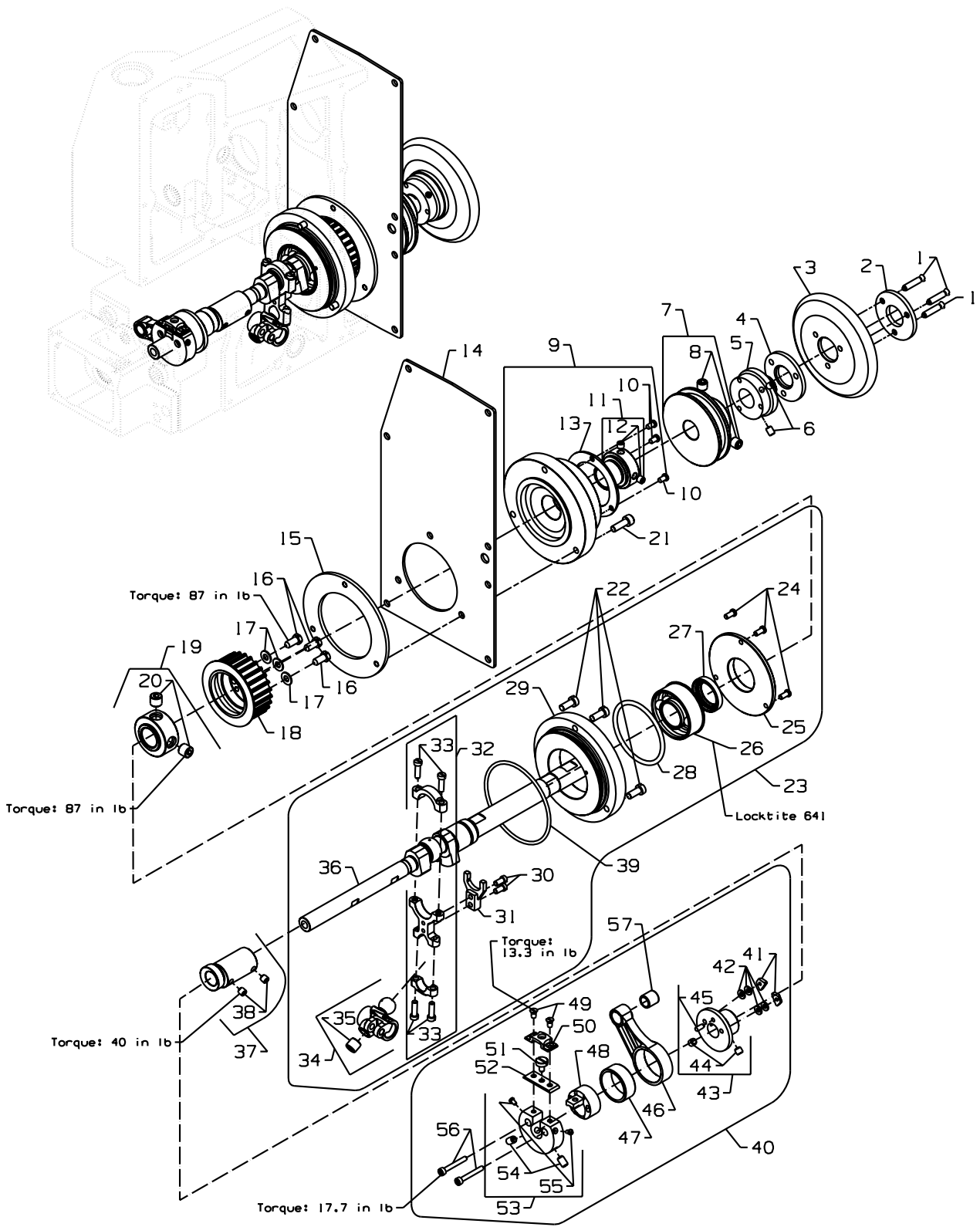

CRANKSHAFT ASSEMBLY

Ref. No.	Part No.	Description	Amt. Req.
1.	22574A	Screw	3
2.	35721H	Pulley hub	1
3.	61321J	Handwheel	1
4.	35721G	Spacing Plate	1
5.	10021J	Handwheel Adapter Hub	1
6.	95500	Screw	2
7.	10021N	Pulley	1
8.	22650CF6	Screw, set	3
9.	10042M	Bearing Housing Assembly	1
10.	SS4111215SP	Screw	2
11.	10033P	Bearing Adapter	1
12.	SS8660612TP	Screw	2
13.	80885C	Ring, Bearing Retainer	1
14.	10082Y	Cover, belt drive	1
15.	10082Z	Bearing Retainer	1
16.	SS9151420TP	Screw	3
17.	WP0621016SD	Washer	3
18.	10042	Sprocket, feed drive	1
19.	10021B	Hub	1
20.	22894AV	Screw, set	2
21.	SS6151812TP	Screw	3
22.	SS6151440SP	Screw	3
23.	29126FY	Crankshaft Assembly	1
24.	SS4111215SP	Screw	3
25.	10042C	Flange Cover	1
26.	660-1031	Bearing	1
27.	660-1103	Lip Seal	1
28.	660-1104	"O" Ring	1
29.	10042B	Flange	1
30.	SS6121060SP	Screw	2
31.	10035A	Guide Fork	1
*32.	10045C	Connecting Rod	1
33.	SS7121610SP	Screw	4
*34.	10013	Looper Drive Rocker	1
35.	22894AV	Screw, set	1
*36.	10022X	Crankshaft	1
37.	10040C	Eccentric	1
38.	SS8660612TP	Screw, set	2
39.	660-1028	"O" Ring	1
40.	29126FS	Stitch Length Adj. Mechanism	1
41.	10095E	Nut	2
42.	660-1047	Washer	4
43.	10042A	Flange	1
44.	SS8660612TP	Screw, set	2
45.	96519	Pin	1
*46.	10045H	Connecting Rod	1
*47.	660-1036	Bearing, needle	1
48.	10040A	Eccentric	1
49.	SS1110840SP	Screw	2
50.	10082D	Cover	1
51.	22599F	Screw, adjustment	1
*52.	10037E	Disc Segment	1
53.	10085	Disc	1
54.	SS8661012TP	Screw, set	2
55.	SS7080520SP	Screw	2
56.	SM6043002TN	Screw	2
57.	660-1035	Bearing	1

*NOTE: Not sold separately

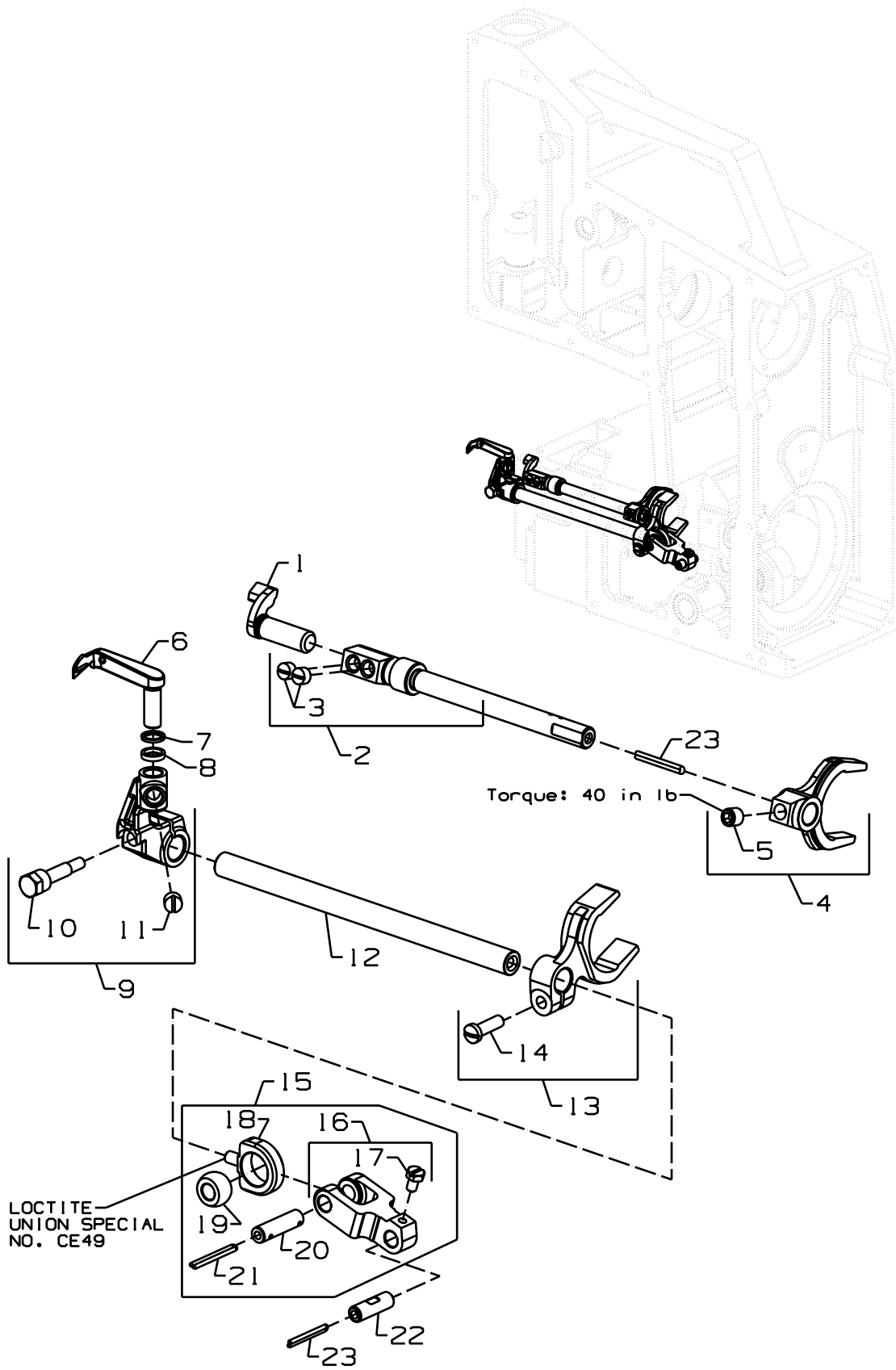

LOOPER DRIVE AND NEEDLE GUARD DRIVE

Ref. No.	Part No.	Description	Amt. Req.
1.	10025A	Needle Guard	1
2.	10022E	Shaft, needle guard	1
3.	SS8150510TP	Screw, set	2
4.	10035	Fork, needle guard	1
5.	SS8660612TP	Screw, set	1
6.	10008B	Looper	1
7.	80137A	Collar 1 mm thick (if required only)	1
8.	80137	Collar 1.8 mm thick (if required only)	1
9.	10013B	Looper Holder	1
10.	22894AW	Screw	1
11.	SS8660610TP	Screw	1
12.	10043	Looper Bar	1
13.	10035C	Fork, connecting	1
14.	SS7111410SP	Screw	1
15.	29105BF	Fork Assembly, looper drive	1
16.	10035B	Fork, connection	1
17.	SS9090640SP	Screw	1
18.	10035E	Joint, looper drive	1
19.	10088	Ball	1
20.	10045J	Pin, link	1
21.	CL21	Wick	1
22.	10045K	Pin, link	1
23.	CL21	Wick	2

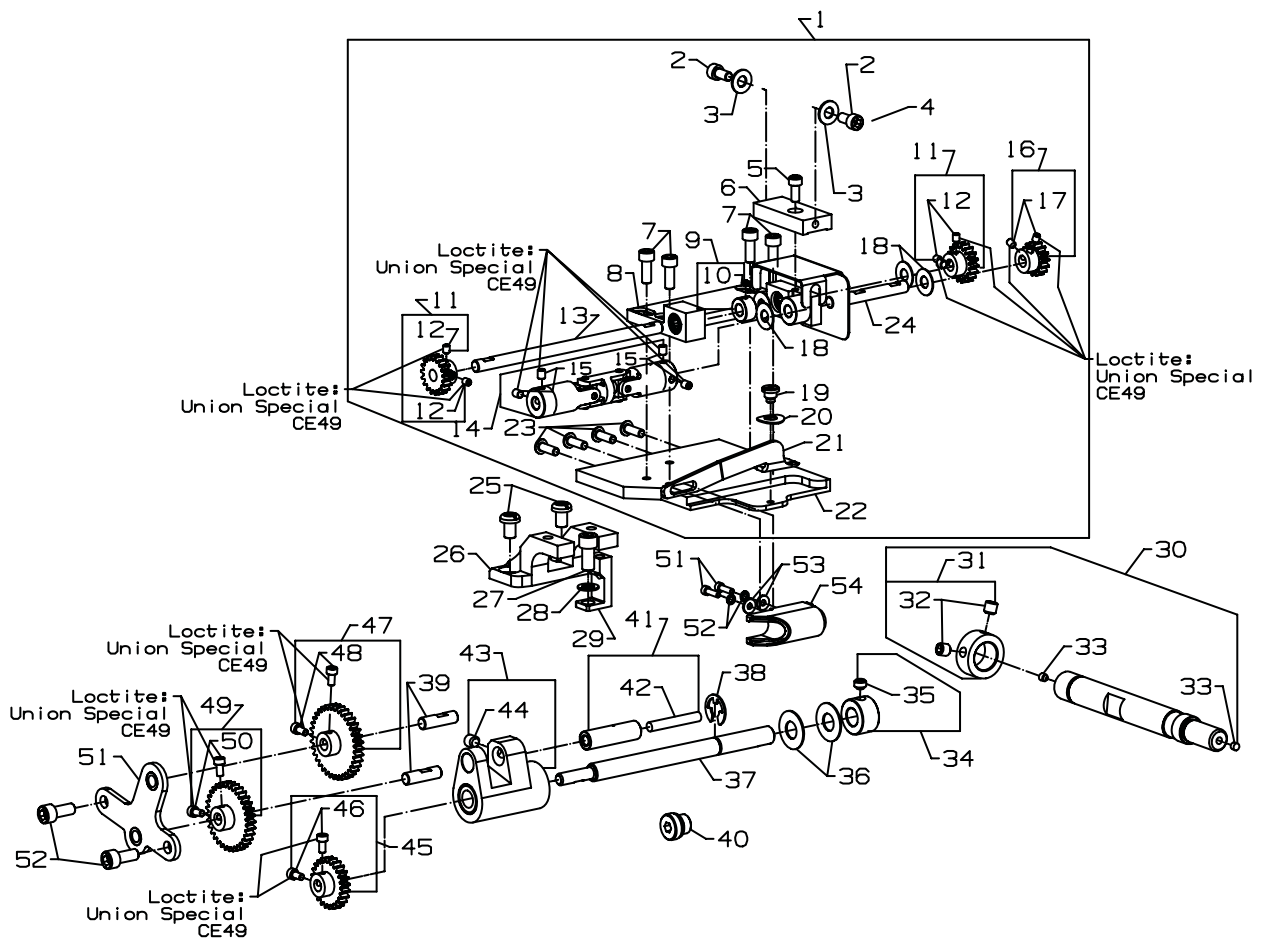
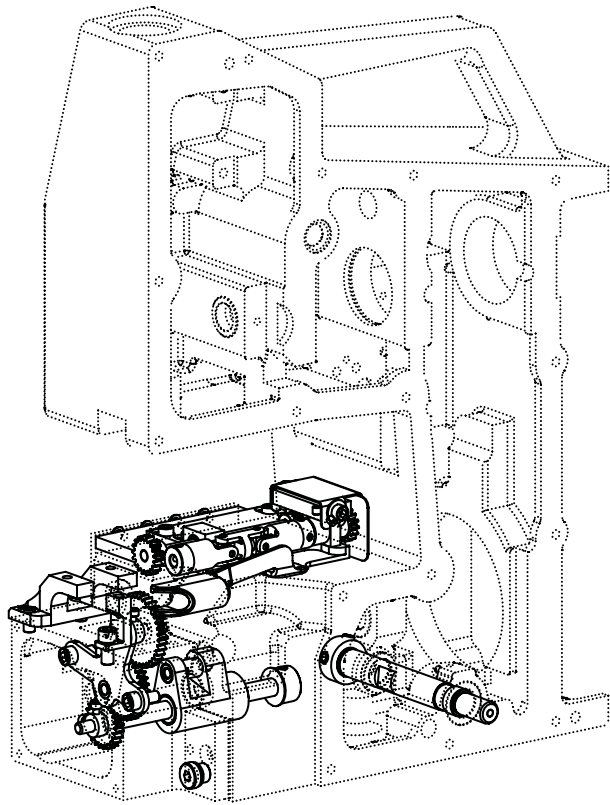

DRIVE PARTS AND THROAT PLATE SUPPORTS

Ref. No.	Part No.	Description	Amt. Req.
1.	29126GA	Upper Roller Drive Assembly	1
2.	22652B6	Socket Head Cap Screw	2
3.	RM3293-6	Washer	2
4.	10082AB	Cover, rear gear	1
5.	22652A6	Socket Head Cap Screw	1
6.	10083AJ	Block, cover mount	1
7.	22653B8	Screw	4
8.	10039G	Housing, roller shaft	1
9.	RM3058-10	Collar	1
10.	22650AA2	Screw	1
11.	10039K	Gear, feed roller	2
12.	RM2808-3	Screw	2
13.	10022Y	Drive Shaft, upper	1
14.	10039L	Universal Joint	1
15.	RM2810-1	Screw	1
16.	10039C	Gear, roller drive	1
17.	RM2808-3	Screw	1
18.	10086C	Thrust Washer	4
19.	22735B	Screw, folder pivot	1
20.	12957E	Washer	1
21.	10064A	Swing Arm, folder	1
22.	10062G	Plate, gear mounting	1
23.	RM4414-1	Button Head Cap Screw	4
24.	10022Z	Connection Shaft, upper	1
25.	SS4150915SP	Screw	2
26.	10080F	Support, throat plate	1
27.	22653D8	Screw	1
28.	6042A	Washer	1
29.	10080E	Support, throat plate front	1
30.	10022P	Shaft, drive	1
31.	10033C	Collar	1
32.	SS8660612TP	Screw	2
33.	—	Plug	2
34.	RM3058-2	Collar	1
35.	22651CD3	Screw	1
36.	AS47-229BR	Washer	2
37.	10022S	Feed Rocker Shaft	1
38.	RM3144-8	E-ring	1
39.	10022R	Shaft, drive gear	1
40.	GR-999-196	Plug, oil pan	1
41.	10045L	Link Pin	1
42.	CL21	Wick	1
43.	670N9	Clutch, feed driving	1
44.	SS8660612TP	Screw	1
45.	10039E	Feed Drive Gear	1
46.	RM2815-2	Screw	1
47.	10039D	Intermediate Gear	1
48.	RM2815-2	Screw	1
49.	10039F	Intermediate Gear	1
50.	RM2815-2	Screw	1
51.	10062D	Drive Gear Support Plate	1
52.	SS6151412TP	Screw	1
53.	RM2984B	Screw	2
54.	RM3993-7	Lockwasher	2
55.	41358	Washer	2
56.	23215BH1-7/16	Folder, for 1-7/16" Tape 1/2" opening	1

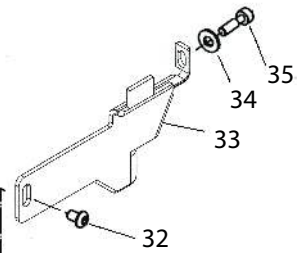
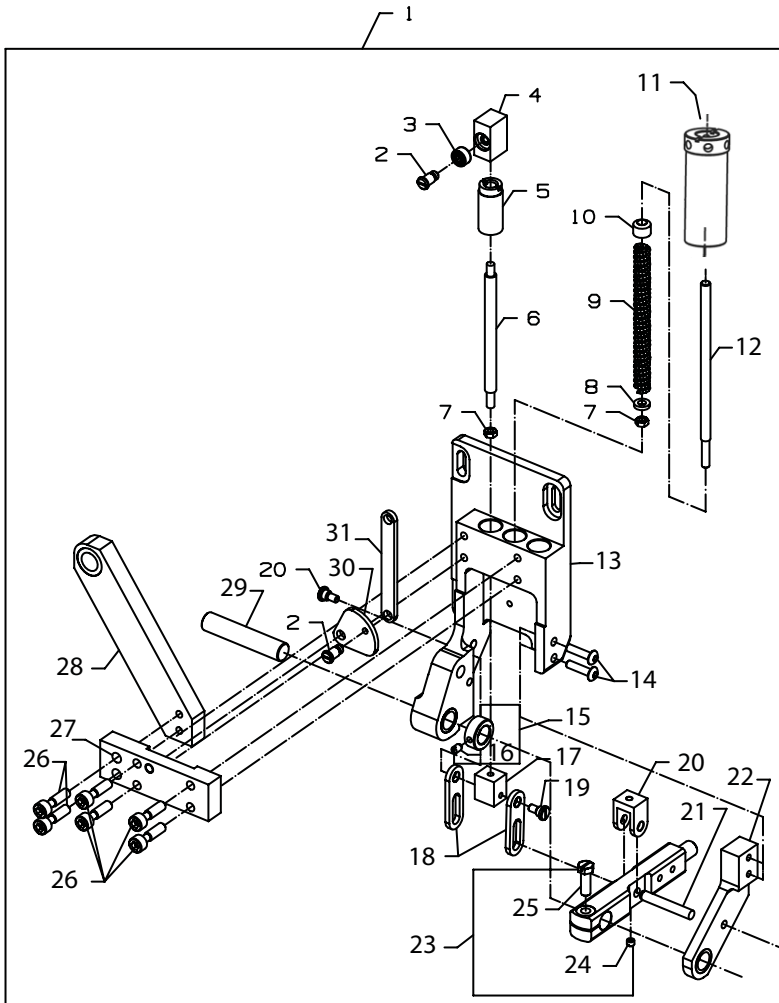
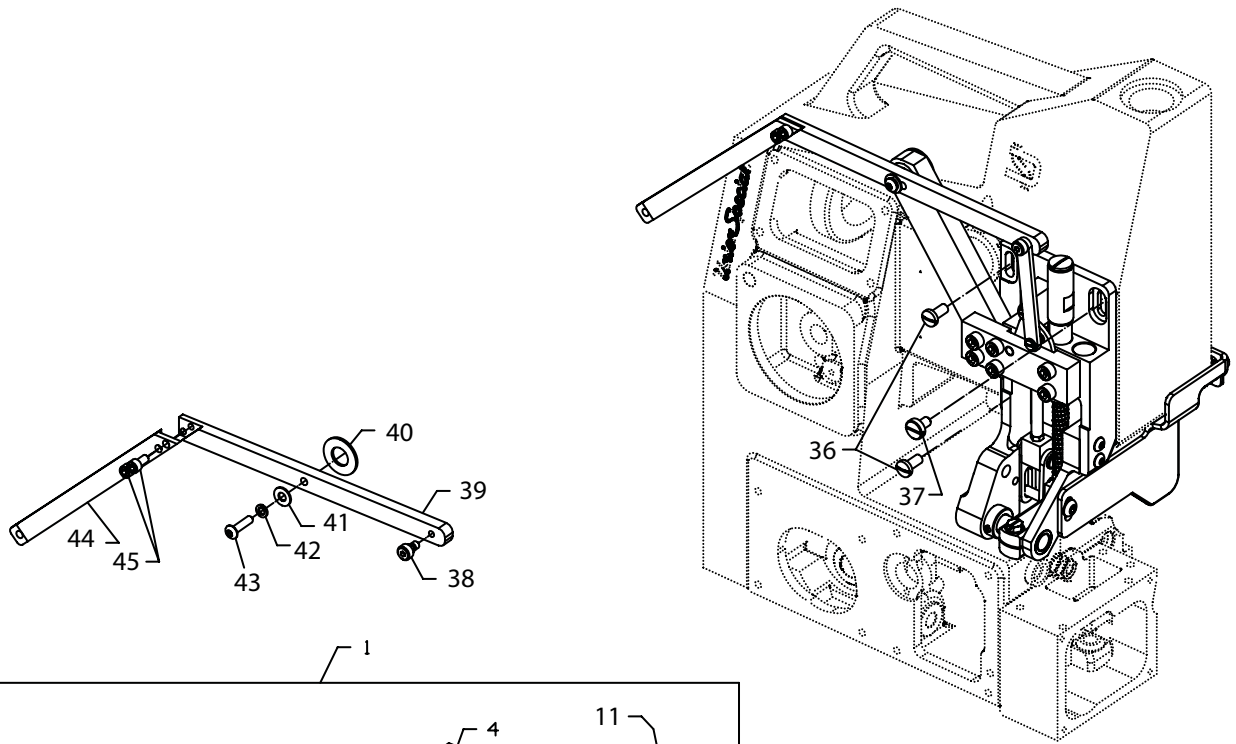

PRESSER FOOT LIFT

Ref. No.	Part No.	Description	Amt. Req.
1.	29126FZ	Presser Foot Lift Assembly	1
2.	36236J	Screw, socket shoulder	2
3.	660-336	Needle bearing	1
4.	10038F	Link Block, follower to shaft	1
5.	10044BL	Bushing, feed lift shaft	1
6.	10043A	Shaft, feed lift	1
7.	NS6120310SP	Nut, hex	2
8.	2015N	Washer	1
9.	10032K	Presser Spring	1
10.	10037C	Bushing, presser foot lifter guide	1
11.	C10030Y	Screw, regulator	1
12.	10056	Presser Rod Bar	1
13.	10083AF	Presser Foot Lift Support	1
14.	RM4489-1	Button Head Cap Screw	2
15.	10033L	Collar	1
16.	SS8110740SP	Screw	1
17.	10038E	Block, shaft linkage	1
18.	10035D	Presser Foot Lifter Link	2
19.	SD0640326TP	Screw, shoulder	2
20.	G671G20	Fork, hinge	1
21.	667H40	Dowel Pin	1
22.	10083AG	Lift Support Bracket	1
23.	10067G	Presser Foot Lever	1
24.	SS8120410SP	Screw, set	1
25.	SS9151740CP	Screw	1
26.	SS6152212SP	Screw	6
27.	10083AH	Mount, feed roll lift	1
28.	10062F	Plate, shaft support mounting	1
29.	10022AA	Shaft	1
30.	10038G	Cam	1
31.	10035J	Connecting Link, feed lift	1
32.	RM4475-1	Screw	1
33.	10096D	Needle Bar Guard	1
34.	6042A	Washer	1
35.	SS6152212SP	Screw	1
36.	SS7151310TP	Screw	2
37.	SS6151040SP	Screw	1
38.	RM4316-29	Screw	1
39.	10056A	Arm, connecting, feed lift	1
40.	RM3239-1	Washer	1
41.	RM3293-6	Washer	1
42.	RM3993-3	Washer, spring	1
43.	RM4489-1	Screw	1
44.	10056C	Feed Lift Arm Extension	1
45.	RM3306-3	Screw	1

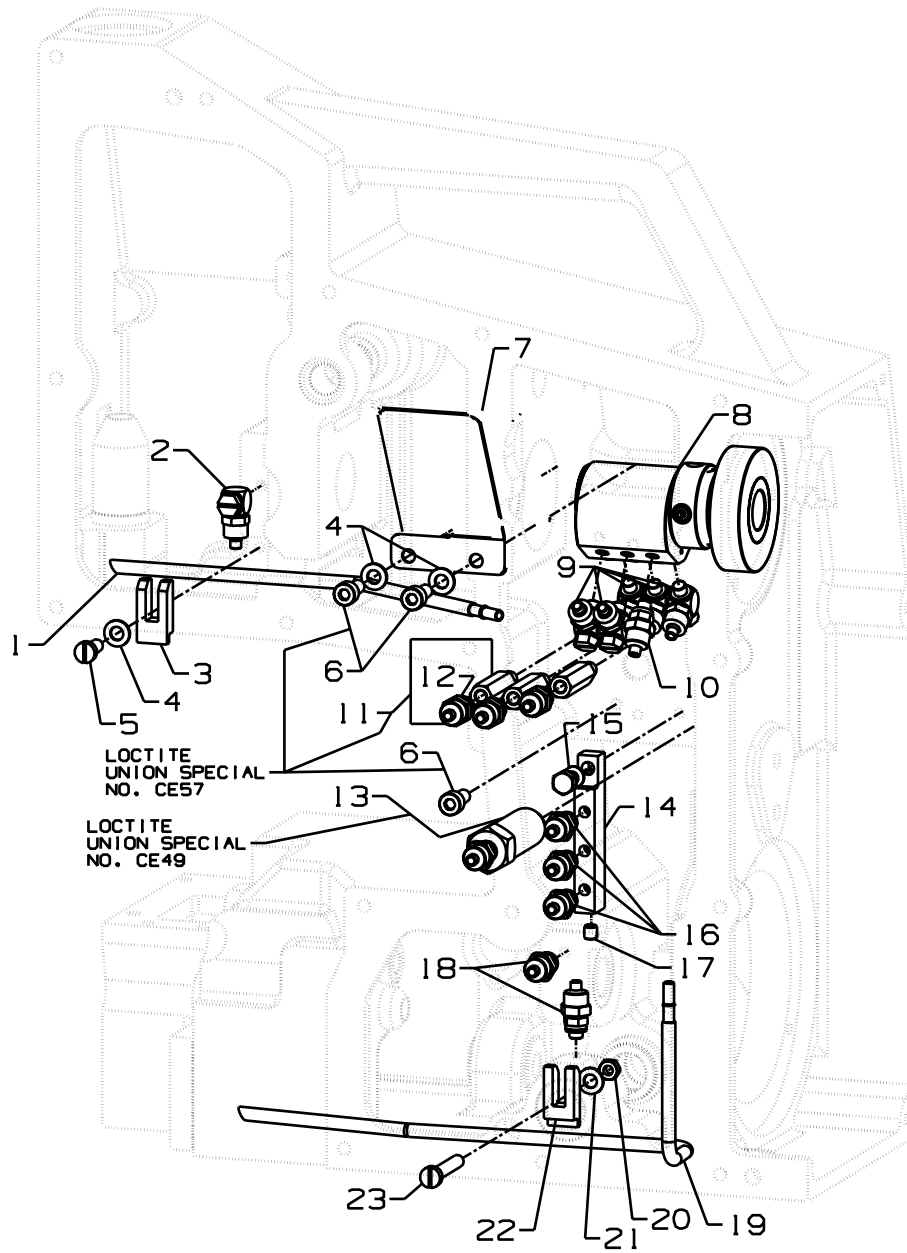

OIL PUMP

Ref. No.	Part No.	Description	Amt. Req.
1.	AS96-701	Oil Tube, suction	1
2.	660-3003	Rotary Fitting	1
3.	10093T	Clamp, oil tube	2
4.	WP0531000SE	Washer	2
5.	SS6121210SP	Screw	5
6.	SM6051202TP	Screw	3
7.	10093AR	Oil Deflection Plate	1
*8.	10093AY	Oil Pump Assembly	1
9.	660-3003	Elbow Fitting	5
10.	660-3004	Straight Fitting	1
11.	10093CL	Stand-off	3
12.	660-3004	Straight Fitting	1
13.	10093CN	Stand-off	1
14.	10093U	Oil Distributor	1
15.	10093AK	Screw, hollow	1
16.	660-3004	Straight Fitting	3
17.	18C94-23	Screw	1
18.	660-3004	Straight Fitting	2
19.	AS96-700	Oil Tube, suction	1
20.	NS6120310SP	Nut	1
21.	WP0531000SE	Washer	1
22.	10093T	Clamp, oil tube	1
23.	SS6123010SP	Screw	1

* Sold only as a tested assembly

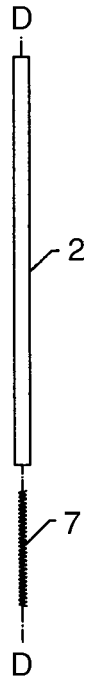
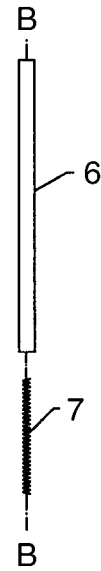
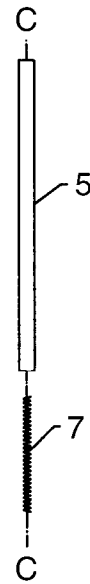
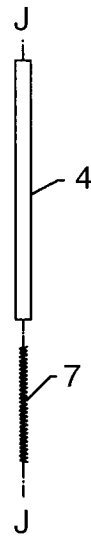
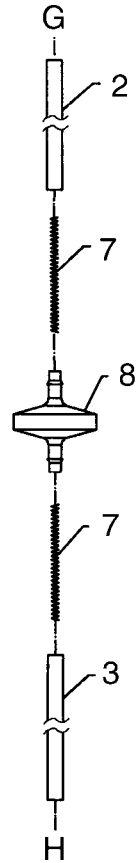
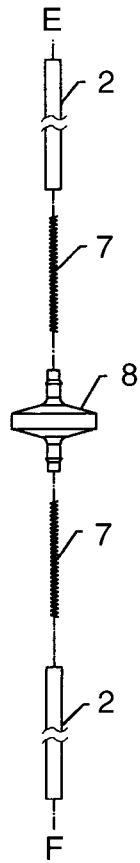
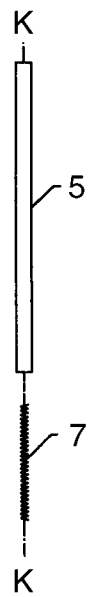
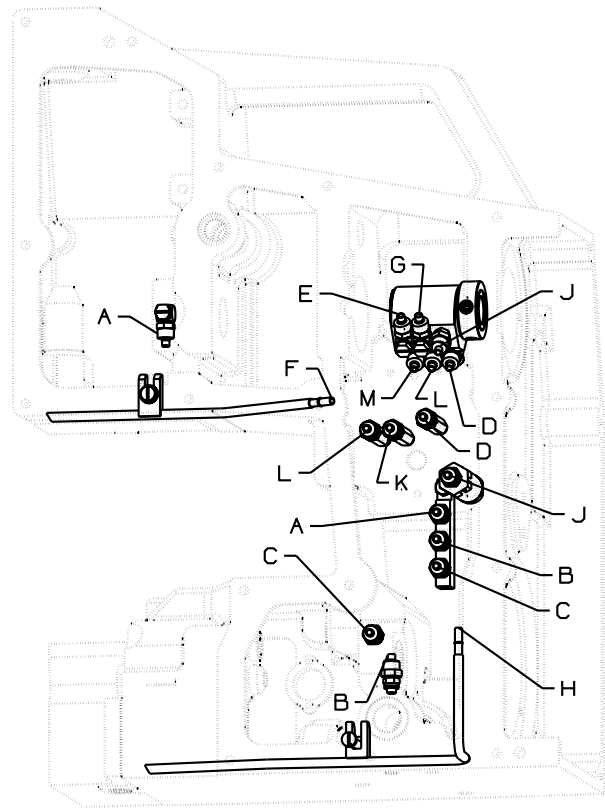
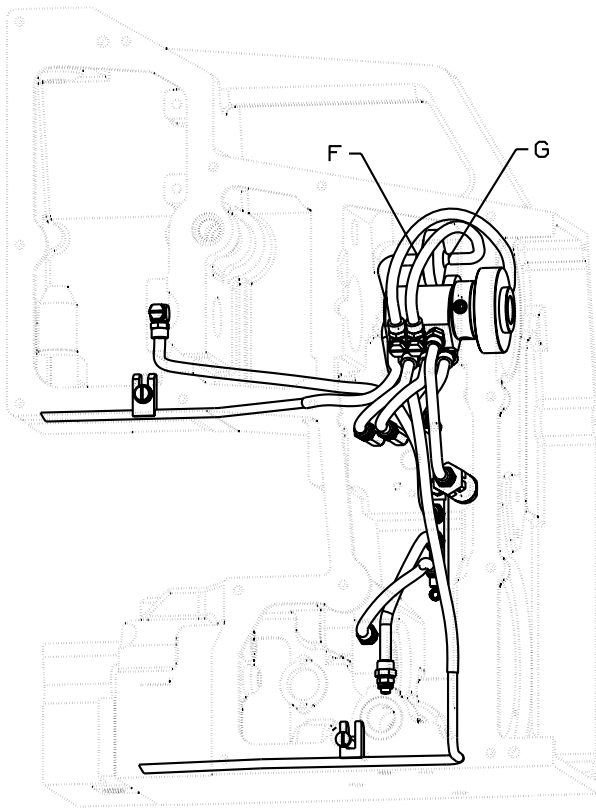

OIL TUBES

Ref. No.	Part No.	Description	Amt. Req.
1.	10093AH	Oil Tube, 220mm Long	1
2.	10093-4	Oil Tube, 178mm Long	4
3.	10093-2	Oil Tube, 330mm Long	1
4.	10093AD	Oil Tube, 100mm Long	1
5.	10093AF	Oil Tube, 120mm Long	3
6.	10093-7	Oil Tube, 117mm Long	1
7.	56393N	Spring	13
8.	660-1071	Oil Filter	2

Set Details
24 and 26 to
90mm
(3.5")

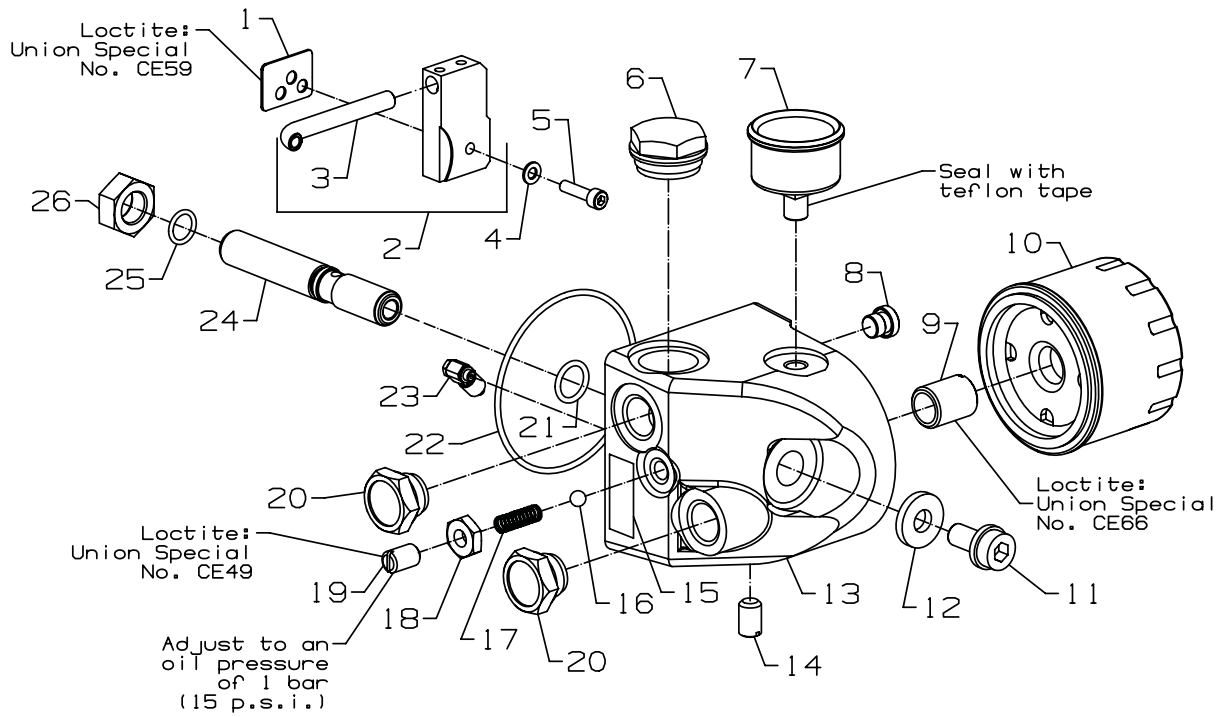
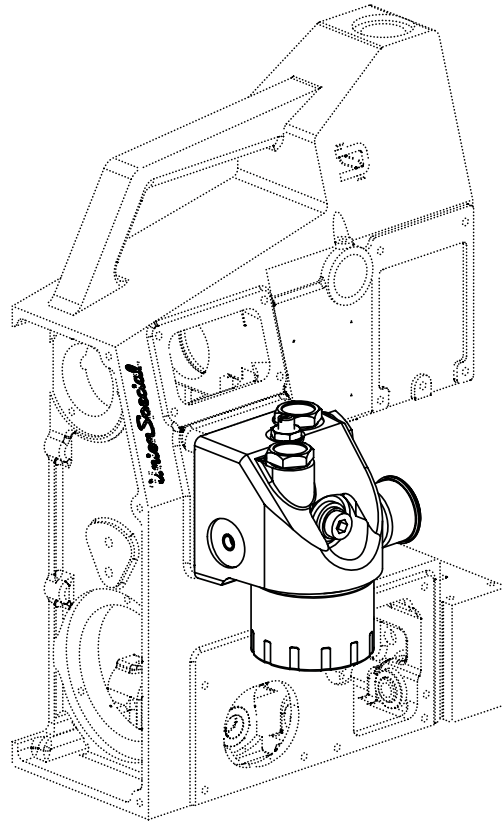
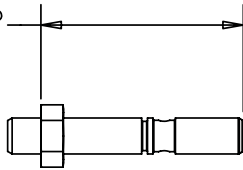

OIL DISTRIBUTOR ASSEMBLY

Ref. No.	Part No.	Description	Amt. Req.
1.	10084	Gasket	1
2.	GR10093A	Oil Distributor	1
*3.	----	Oil Tube	1
4.	WP0531000SE	Washer	1
5.	SM6052002TP	Screw	1
6.	671D57	Oil Level Gauge	1
7.	10093AU	Oil Pressure Gauge	1
8.	P-199-196	Screw, plug, oil drain	1
9.	10093CM	Tube, threaded	1
10.	671D55	Oil Filter	1
11.	660-1125	Screw	1
12.	660-1124	Washer	1
13.	10093AV	Housing, distribution	1
14.	22599N	Screw, set	1
15.	999-124BCO	Stick-on Label	1
16.	10088C	Ball	1
17.	10032A	Spring	1
18.	GR-660-1068	Nut	1
19.	22599N	Screw, set	1
20.	22599M	Screw, plug	2
21.	660-1123	"O" Ring	1
22.	660-1025	"O" Ring	1
23.	660-3003	Fitting, rotary	1
24.	10093AT	Oil Distribution Stud	1
25.	660-1027	"O" Ring	1
26.	660-1126	Nut	1

* NOTE: Not sold separately

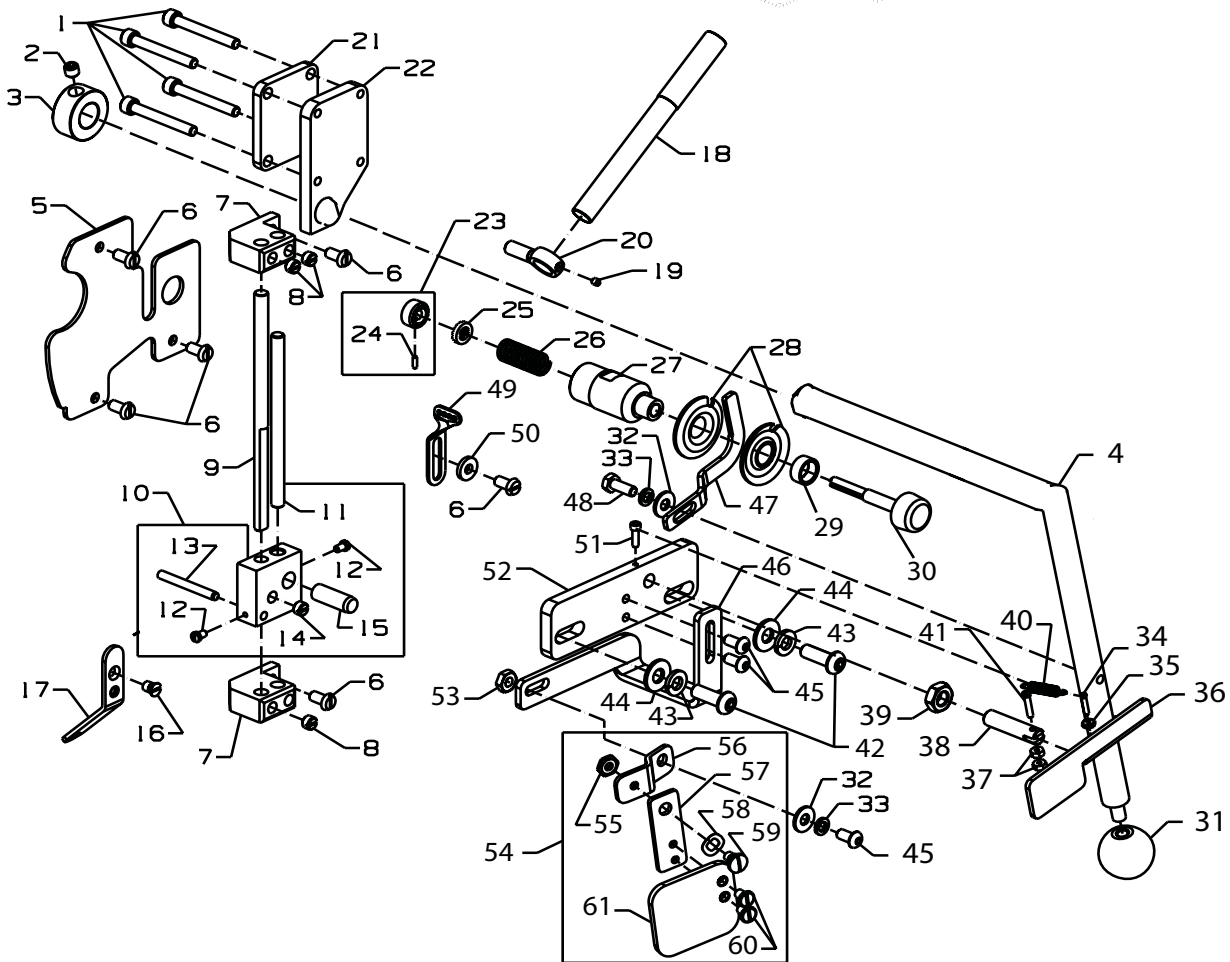
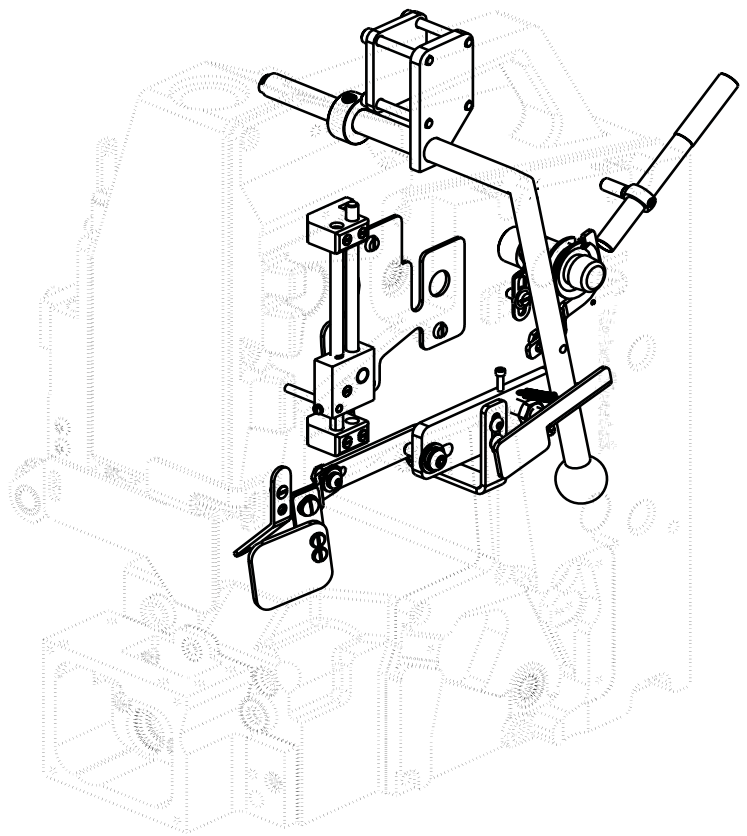

NEEDLE THREAD CONTROL

Ref. No.	Part No.	Description	Amt. Req.
1.	22653B24	Screw	4
2.	22650CD4	Screw	1
3.	RM3058-11	Collar	1
4.	10038B	Shaft, roller lift arm	1
5.	10082Q	Cover	1
6.	SS6121050SP	Screw	6
7.	10066C	Support, thread control	2
8.	SS8660410SP	Screw, set	4
9.	10047	Pin	1
10.	10066B	Guide, thread	1
*11.	----	Pin	1
12.	SS7080520SP	Screw	2
13.	10047J	Pin	1
14.	SS8660410SP	Screw, set	1
15.	10047H	Pin	1
16.	SS1120710SP	Screw	1
17.	10068B	Guide, thread	1
18.	10066D	Guide, thread	1
19.	28C	Screw, set	1
20.	80858BX1	Support, thread guide	1
21.	10038D	Shaft Support Plate, rear	1
22.	10038C	Shaft Support Plate, front	1
23.	10092	Nut, tension regulator	1
*24.	----	Pin	1
25.	39592AK	Ferrule, tension	1
26.	110-4	Spring	1
27.	10044B	Bushing	1
28.	80676A	Disc, tension	2
29.	GR-10044A	Bushing	1
30.	10092A	Knob, tension	1
31.	50667A	Handle knob	1
32.	RM3293-6	Washer	2
33.	RM3993-3	Washer, lock	2
34.	22738D	Screw	1
35.	60078Z	Nut	1
36.	10047Q	Latch	1
37.	10047R	Nut	1
38.	SC524	Stop. lock	1
39.	RM3211-14	Nut	1
40.	10032G	Extension Spring, latch	1
41.	22767A	Screw	1
42.	RM4485-2	Screw	1
43.	RM3993-8	Washer, lock	2
44.	RM3293-1	Washer	2
45.	22659B8	Screw	2
46.	10083AD	Mounting Bracket, shield	1
47.	10067F	Tension Release Lever	1
48.	RM4375-1	Screw	1
49.	51858	Guide, thread	1
50.	WP0482086SD	Washer	1
51.	RM2984B	Screw	1
52.	10062E	Latch Mounting Plate	1
53.	651H	Nut	1
54.	99682XCB	Needle Protection Shield Assembly	1
55.	NS6620320SP	Nut	1
56.	50383AE	Bracket Holder	1
57.	50385AD	Bracket	1
58.	WZ0641510KP	Washer, spring	1
59.	SD0640323TP	Screw	1
60.	SS6110610TP	Screw	2
61.	99682XC3	Protective Shield	1

* NOTE: Not sold separately

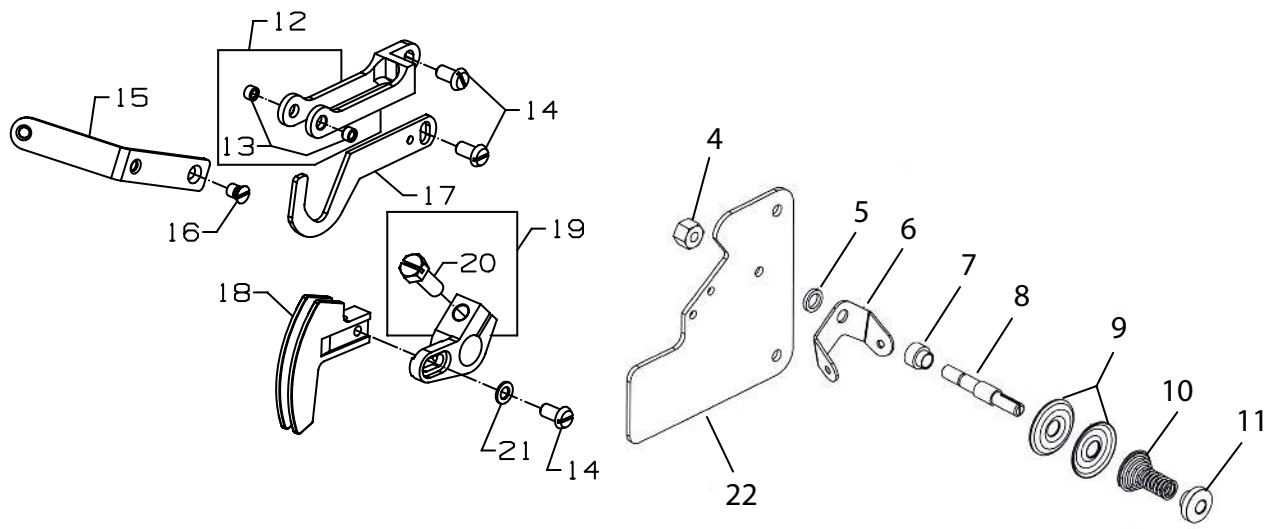
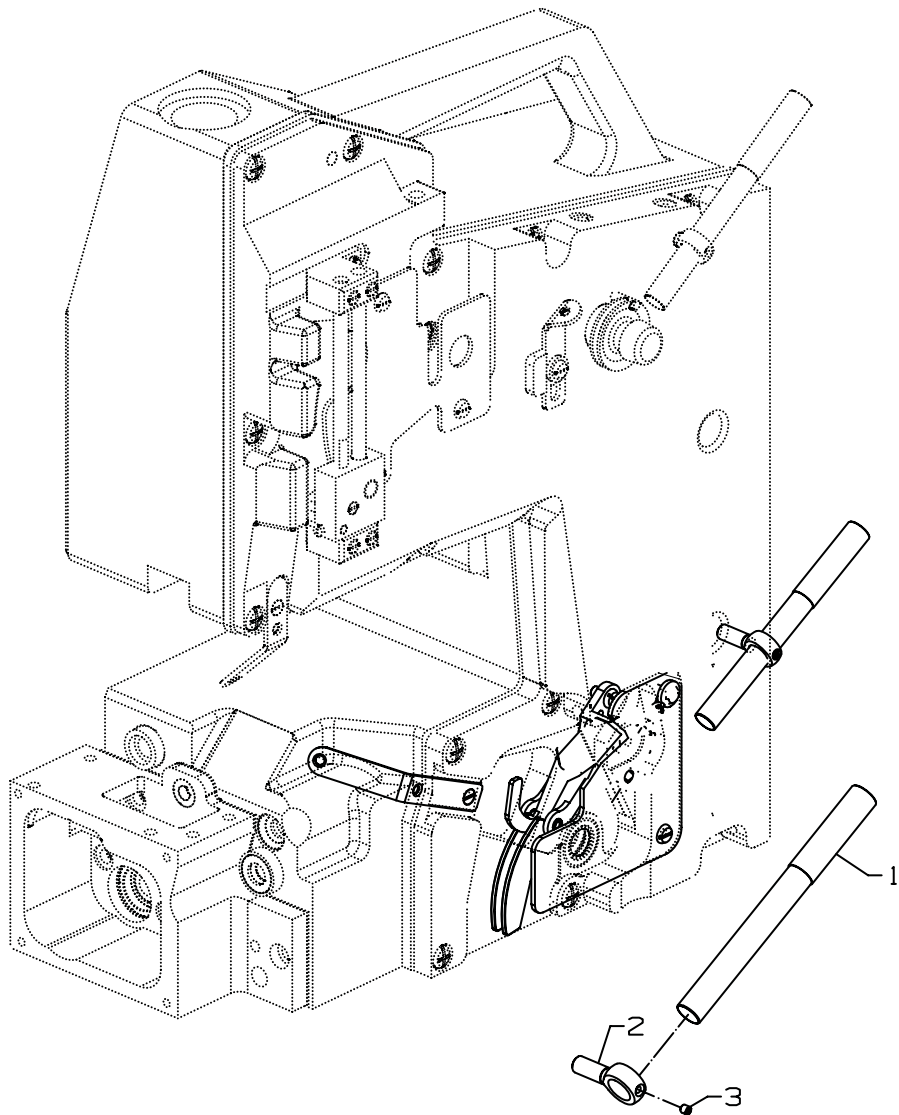

LOOPER THREAD CONTROL

Ref. No.	Part No.	Description	Amt. Req.
1.	10066D	Guide, thread.....	1
2.	80858BX-1	Support, thread guide	1
3.	28C	Screw, set	1
4.	43266	Nut	1
5.	39580F	Washer.....	1
6.	51192G	Eyelet	1
7.	51192B	Ferrule	1
8.	51292	Tension Post.....	1
9.	109	Tension Disc	2
10.	39592AR8	Tension Spring	1
11.	51292C	Tension Nut	1
12.	10068D	Guide, thread.....	1
13.	10068E	Eyelet	2
14.	SS6121050SP	Screw	5
15.	10068C	Guide, thread.....	1
16.	SS1120710SP	Screw	1
17.	10023B	Hook, thread	1
18.	10023	Take-up, thread	1
19.	10048	Lever	1
20.	SS9151630CP	Screw	1
21.	WP0480856SP	Washer	1
22.	10082W	Cover	1

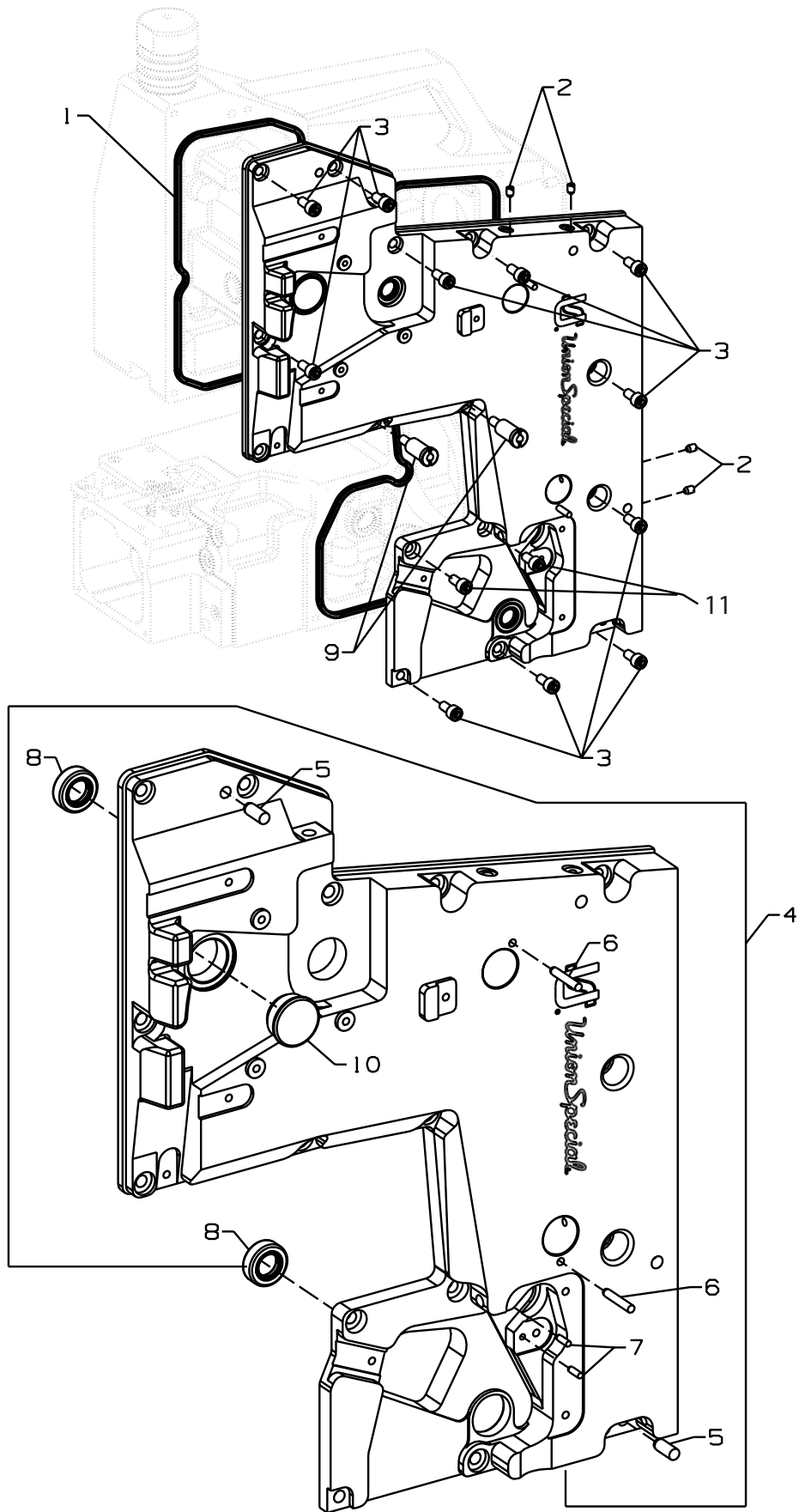

FRONT AND LOOPER COVERS

Ref. No.	Part No.	Description	Amt. Req.
1.	10084C	Seal, quad-ring	1
2.	SS812074OSP	Screw, set	4
3.	22894BM	Screw	14
4.	10082P	Cover, front	1
5.	660-1067	Pin	2
6.	660-1094	Pin	2
7.	96535	Pin	2
8.	660-1127	Lip Seal	2
9.	10067E	Stand-off, metering tape cutter	2
10.	TA2351004R0	Plug.....	1
11.	SS6151812TP	Screw.....	2

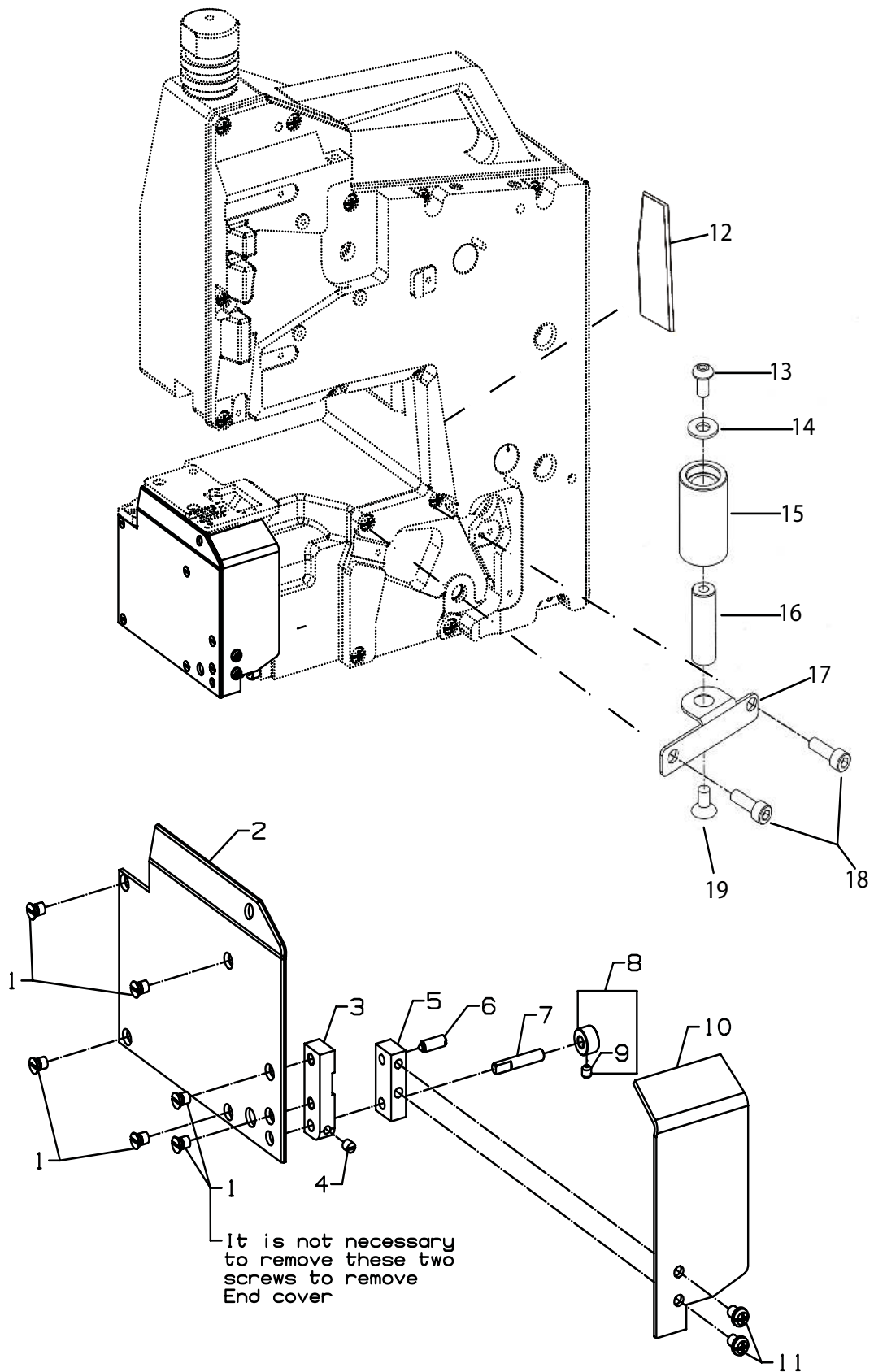

COVERS

Ref. No.	Part No.	Description	Amt. Req.
1.	SS1120710SP	Screw	6
2.	10082S	End Cover	1
3.	10083AA	Support Block, swing cover	1
4.	SS8110510SP	Screw	1
5.	10083AB	Swing cover, mounting bracket	1
6.	C50041J	Spring Plunger	1
7.	10022Q	Shaft, swing cover	1
8.	10033N	Collar, swing cover shaft	1
9.	RM2810-1	Screw	1
10.	10082T	Swing Cover	1
11.	SS4120615SP	Screw	2
12.	10062L	Tape guide plate.....	1
*13.	22658D8	Screw.....	1
*14.	RM3293-1	Washer.....	1
*15.	10077	Front roller.....	1
*16.	10022AB	Front roller shaft.....	1
*17.	10083AP	Front roller bracket.....	1
*18.	SS6151812TP	Screw.....	2
*19.	RM4485-2	Screw.....	1

* Purchase complete as 29480BEK

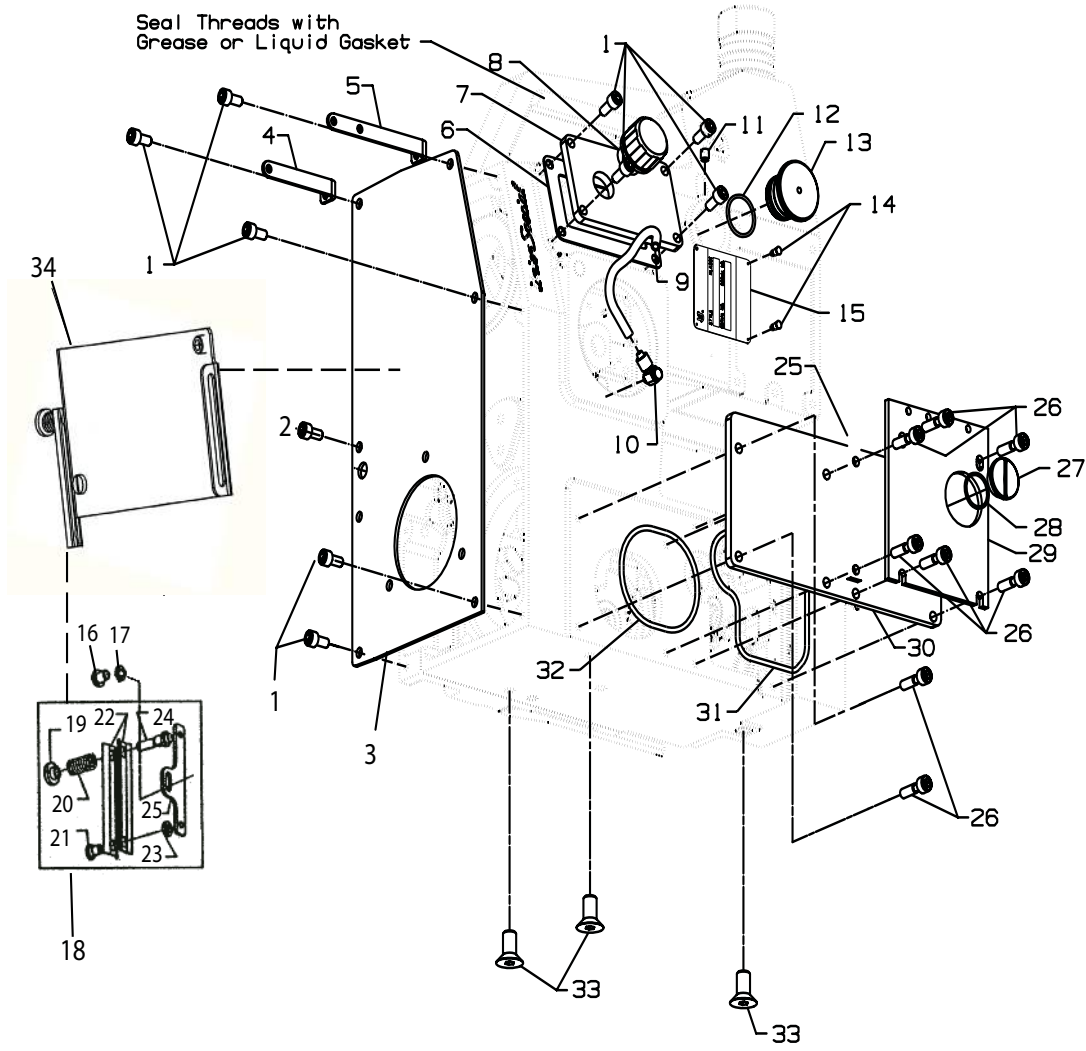

BACK AND RIGHT COVERS

Ref. No.	Part No.	Description	Amt. Req.
1.	22894BM	Screw	9
2.	SS7151210TP	Screw	1
3.	10082Y	Cover	1
4.	10068G	Looper Thread Eyelet	1
5.	10058G	Thread Eyelet	1
6.	10084D	Gasket, filter housing	1
7.	10082R	Cover, filter housing	1
8.	10094	Vent	1
9.	10093AM	Oil Tube 6x4; 0.33 m long	1
10.	660-3003	Oil Fitting, rotary	1
11.	SS8150710SP	Screw, set	1
12.	660-705	"O" Ring	1
13.	670G224	Plug	1
*14.	----	Pin	4
*15.	----	Plate, style	1
16.	22839C	Screw	1
17.	56342J	Washer.....	1
18.	23306AH	Tape Tension Assembly	1
19.	51292C	Nut	1
20.	51292F14	Spring	1
21.	22845N	Screw	1
22.	23306AJ	Tension Plate	2
23.	54480	Support Spacer	1
24.	23306AN	Tension Post	1
25.	23306AL	Tension Bracket	1
26.	SS6151812TP	Screw	8
27.	22799AK	Screw, plug	1
28.	660-1038	"O" Ring	1
29.	10082V	Back Cover	1
30.	10082G	Cover	1
31.	660-1024	"O" Ring	1
32.	660-1069	"O" Ring	1
33.	95076	Screw, flat head	3
34.	10037P	Tape Tension Mounting Plate.....	1

* NOTE: Not sold separately

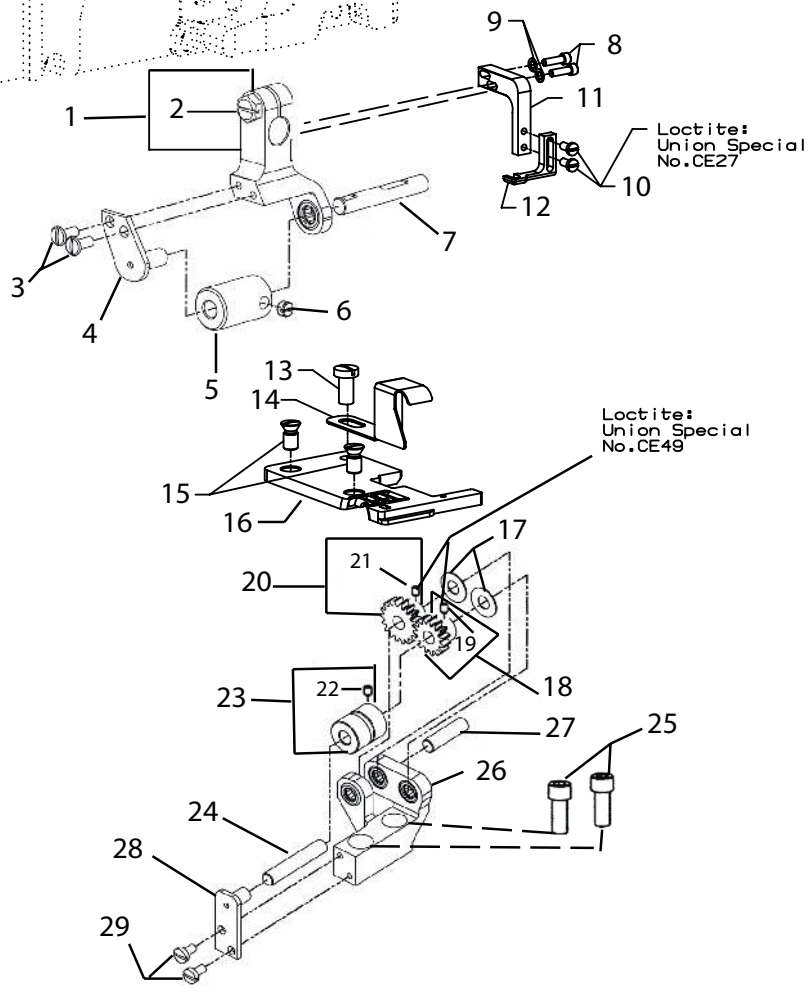
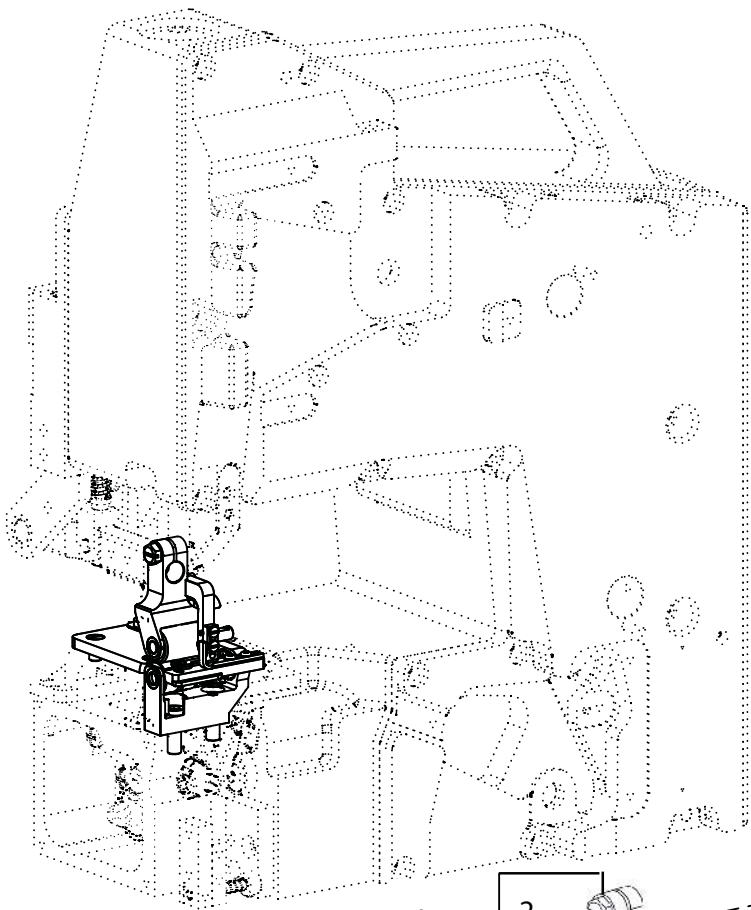

SEWING PARTS

Ref. No.	Part No.	Description	Amt. Req.
1.	10039M	Shank, upper roller	1
2.	SS9151420TP	Screw, set	1
3.	SS7190850SP	Screw.....	2
4.	10039N	Upper Feed Roller Support Plate.....	1
5.	10075J	Upper Feed Roller, 16 teeth Diamond knurl.....	1
-	10075P	Upper Feed Roller, 10 TPI (Optional).....	1
-	10075R	Upper Feed Roller, 12 TPI (Optional).....	1
6.	22580	Screw	1
7.	10022AC	Upper Feed Roller Shaft.....	1
8.	22652K8	Screw	2
9.	40-107	Washer	2
10.	22768B	Screw	2
11.	10030AA	Presser Foot Shank	1
12.	10020G	Presser Foot Bottom	1
13.	SS7151210SP	Screw	1
14.	10096A	Gear Cover	1
15.	22599L	Screw	2
16.	10024G	Throat Plate, tape edge	1
17.	10086C	Thrust Washer	2
18.	10039C	Puller Drive Gear	1
19.	RM2808-3	Screw	2
20.	10039K	Feed Drive Gear	1
21.	RM2808-3	Screw	2
22.	98	Screw	1
23.	10075L	Lower Feed Roller, 16 teeth Diamond Knurl	1
-	10075Q	Lower Feed Roller, 10 TPI (Optional).....	1
-	10075N	Lower Feed Roller, 12 TPI (Optional).....	1
24.	10022AE	Lower Roller Shaft	1
25.	RM2797-2	Screw	2
26.	10039P	Lower Roller Base	1
27.	10022W	Gear Support Shaft	1
28.	10039R	Lower Roller Support Plate.....	1
29.	SS7090710SP	Screw.....	2

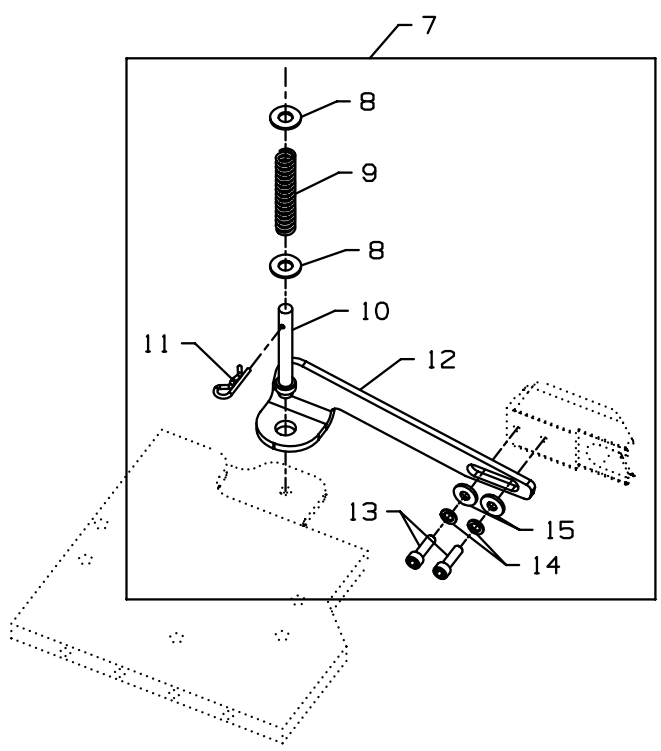
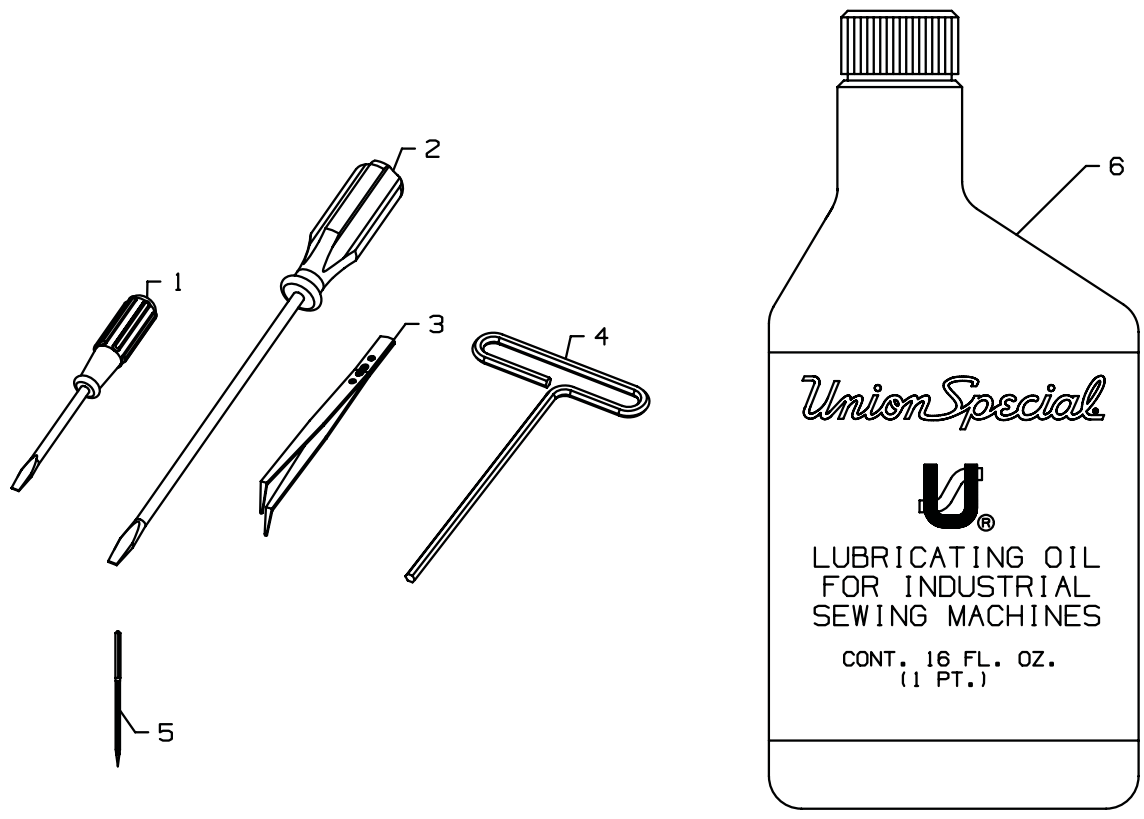

ACCESSORIES

Ref. No.	Part No.	Description	Amt. Req.
1.	22933105	Screw Driver	1
2.	22933006	Screw Driver	1
3.	B9204804000	Tweezers	1
4.	WR83	Allen Wrench 5mm	1
5.	794HSERV4-180/073	Needle	10
6.	28604R	Oil Bottle 0.5 liter	1
*7.	29480BEM	Folder change kit	1
*8.	61377Q	Washer	2
*9.	10032E	Spring	1
*10.	22799AP	Shoulder Screw	1
*11.	10047P	Hairpin Cotter Pin	1
*12.	10064A	Swing Arm, Folder	1
*13.	RM2984B	Screw	2
*14.	RM3993-7	Screw	2
*15.	41358	Washer	2

* Extra send and charge

NUMERICAL INDEX OF PARTS

<u>Part No.</u> <u>Page</u>	<u>Part No.</u> <u>Page</u>	<u>Part No.</u> <u>Page</u>	<u>Part No.</u> <u>Page</u>
10008B 29	10038F 33	10054B 21	10085 27
10013 27	10038G 33	10056 33	10086C 31, 51
10013B 29	10039M 51	10056A 33	10088 29
10016A 23	10039C 31, 51	10056B 41	10088C 39
10016B 23	10039D 31	10056C 33	10091 23
10017 23	10039E 31	10058G 49	10092 41
10018B 23	10039F 31	10062D 31	10092A 41
10020G 51	10039G 31	10062E 41	10093-2 37
10021B 27	10039K 31, 51	10062F 33	10093-4 37
10021D 25	10039L 31	10062G 31	10093-7 37
10021E 25	10039N 51	10062L 47	10093AD 37
10021J 27	10039P 51	10064A 41, 53	10093AF 37
10021N 27	10039R 51	10066B 41	10093AH 37
10022AA 33	10040A 27	10066C 41	10093AK 35
10022AB 47	10040B 25	10066D 41, 43	10093AM 49
10022E 29	10040C 27	10067 25	10093AR 35
10022F 25	10042 27	10067E 45	10093AT 39
10022G 23	10042A 27	10067F 41	10093AU 39
10022Q 47	10042B 27	10067G 33	10093AV 39
10022R 31	10042C 27	10068B 41	10093AY 35
10022S 31	10042F 25	10068C 43	10093CL 35
10022W 51	10042J 25	10068D 43	10093CM 39
10022X 27	10042K 25	10068E 43	10093CN 35
10022Y 31	10042M 27	10068G 49	10093T 35
10022Z 31	10043 29	10075J 51	10093U 35
10022AC 51	10043A 33	10075L 51	10094 49
10022AE 51	10044AH 21	10075N 51	10095E 27
10023 43	10044AL 21	10075P 51	10095F 23
10023B 43	10044AU 21	10075Q 51	10096 23
10024G 51	10044AV 21	10075R 51	10096A 51
10025A 29	10044AW 21	10076 25	10096D 33
10030AA 51	10044B 41	10077 47	109 43
10032A 39	10044BH 21	10080E 31	110-4 41
10032E 53	10044BJ 21	10080F 31	12957E 31
10032G 41	10044BK 21	10082D 27	18C94-23 35
10033C 31	10044BL 33	10082G 49	2015N 33
10033H 23	10044CGL 21	10082P 45	22574A 27
10032K 33	10044DGL 21	10082Q 41	22599F 27
10033L 33	10044GGL 21	10082R 49	22599L 51
10033M 25	10044GL 21	10082S 47	22599M 39
10033N 47	10044PGL 21	10082T 47	22599N 39
10033P 27	10044SGL 21	10082V 49	22650AA2 31
10035 29	10044XGL 21	10082W 43	22650CD4 41
10035A 27	10045C 27	10082Y 27, 49	22651CD3 31
10035B 29	10045H 27	10082Z 27	22650CF6 27
10035C 29	10045J 29	10082AB 31	22652A6 31
10035D 33	10045K 29	10083 23	22652B6 31
10035E 29	10045L 31	10083AA 47	22652D12 33
10035J 33	10045N 23	10083AB 47	22652K8 51
10037 23	10047 41	10083AD 41	22653B24 41
10037C 33	10047B 23	10083AF 33	22653B8 31
10037E 27	10047H 41	10083AG 33	22653D8 31
110037P 49	10047J 41	10083AH 33	22653D8 47
10038A 23	10047P 53	10083AJ 31	22658D12 41
10038B 41	10047Q 41	10083AP 47	22659B8 41
10038C 41	10047R 41	10084 39	22735B 31
10038D 41	10048 43	10084C 45	22738D 41
10038E 33	10048A 23	10084D 49	22767A 41

NUMERICAL INDEX OF PARTS

<u>Part No.</u> <u>Page</u>	<u>Part No.</u> <u>Page</u>	<u>Part No.</u> <u>Page</u>	<u>Part No.</u> <u>Page</u>
22768B 51	660-1028 27	999-256G 21	SS6110650TP 23
22799AK 49	660-1029 25	AS47-229BR 31	SS6121050SP 41
22799AP 53	660-1031 27	AS96-700 35	SS6121050SP 43
22839C 49	660-1032 21	AS96-701 35	SS6121060SP 27
22845N 49	660-1033 21	B1124804000 ... 23	SS6121210SP 35
22894AV .23, 25, 27	660-1035 27	B9204804000 ... 53	SS6121610TP 23
22894AW 29	660-1036 27	C10030Y.....33	SS6123010SP 35
22894BM 45, 49	660-1037 23	C50041J 47	SS6150810SP 23
22933006 53	660-1038 49	CL21 23, 29, 31	SS6151040SP 33
22933105 53	660-1041 25	CO66 21	SS6151210SP 33
23215BH1-7/16 .. 31	660-1047 27	G10044T 21	SS6151412TP 31
23306AH 49	660-1055 25	G671G20 33	SS6151440SP 27
23306AJ 49	660-1059 23	GR-10044A 41	SS6151812TP....23,27,43
23306AL 49	660-1067 45	GR-660-1068 39	SS6151812TP.....47,49
23306AN 49	660-1069 49	GR10093A 39	SS6152212SP .. 23,33
28604R 53	660-1071 37	NS6120310SP 33	SS7080520SP .. 27,41
28604X 39	660-1085 21	NS6120310SP 35	SS7090850SP.....51
28C 41, 43	660-1094 45	NS6620320SP 41	SS7090710SP.....51
29105BF 29	660-1103 ... 25, 27	P-199-196 ... 31, 39	SS7110570SP 25
29126FP 23	660-1104 27	RM2797-2 51	SS7111410SP 29
29126FS 27	660-1123 39	RM2808-3 31, 51	SS7121610SP 27
29126FY 27	660-1124 39	RM2810-1 31, 47	SS7151210SP..49,51
29126FZ 33	660-1125 39	RM2815-2 51	SS8080410TP 23
29126GA 31	660-1126 39	RM2984B 31, 41	SS8110510SP 47
29476ZS 25	660-1127 45	RM2984B 53	SS8110740SP 33
29480BEK.....47	660-1137 21	RM3058-10 31	SS8120410SP 33
35721G 27	660-1138 21	RM3058-11 41	SS8120740SP 45
35721H 27	660-1141 23	RM3058-2 31	SS8150510TP 29
36236J 33	660-1147 25	RM3144-8 31	SS8150710SP 49
39543R 33	660-212 25	RM3211-14 41	SS8660410SP 41
39580F.....43	660-336 33	RM3239-1 33	SS8660610TP 29
39592AK 41	660-3003 ... 35, 39,49	RM3293-141,47	SS8660612TP. 25,27,29,31
39592AR8.....43	660-3004 35	RM3293-6 31, 33	SS8661012TP 27
40-107 51	660-705 49	RM3293-6 41	SS8661212TP 25
41358 41, 53	667H40 33	RM3306-3 33	SS9090640SP 29
43266 43	670G224 49	RM3993-3 33, 41	SS9151120CP 25
50383AE 41	670N9 31	RM3993-7 31, 53	SS9151420TP 27
50385AD 41	671D55 39	RM3993-8 41	SS9151420TP 51
50667A 41	671D57 39	RM4316-29 33	SS9151630CP 43
51192B.....43	794HSERV4-180/073 ... 23	RM4375-1 41	SS9151740CP 23
51192G.....43	794HSERV4-180/073 ... 53	RM4414-1 31	SS9151740CP 33
51292.....43	80137 29	RM4475-1 33	TA0370601M0 25
51292C43, 49	80137A 29	RM4485-2.....47	TA0950806R0 21
51292F14 49	80676A 41	RM4489-1 ... 33, 41	TA2351004R0 45
51858 41	80858BX-1 43	SC524 41	WP0480856SP 43
54480 49	80858BX1 41	SD0640323TP 41	WP0482086SD 41
56342J 49	80885C 27	SD0640326TP 33	WP0531000SE 35
56393N 37	95076 49	SM6043002TN ... 27	WP0531000SE 39
60078Z 41	95500 27	SM6051202TP ... 35	WP0621016SD 27
6042A 31, 33	95953 25	SM6052002TP ... 39	WP0651001SB 23
61321J 27	96519 27	SM6081802TP ... 25	WR83 53
61377Q 53	96535 45	SS110840SP 27	WZ0641510KP 41
651H 41	98 51	SS1120710SP.. 41,43,47	
660-1018 21	99682XC3 41	SS4111215SP 27	
660-1021 21	99682XCB 41	SS4120615SP 47	
660-1024 49	999-114G 39	SS4150915SP 31	
660-1025 39	999-124BCO 39	SS4151215SP 25	
660-1027 39	999-256F 21	SS6110610TP 41	



JUKI
Union Special