

FINEST QUALITY

Union Special[®]

AUTOMATED SYSTEMS

**STYLE
2800 E-4**

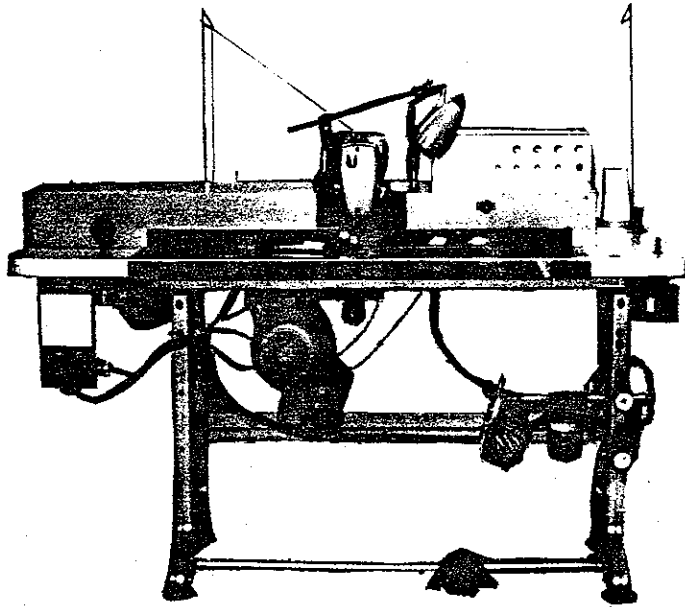

**INSTRUCTIONS
AND
PARTS LIST
FOR
TROUSER FLY SEWING STATION**

**CATALOG
No.
501A
3RD
EDITION**

Union Special[®] CORPORATION

TABLE OF CONTENTS

SECTION 1.....GENERAL INFORMATION

SECTION 2.....INSTALLATION

SECTION 3.....UNIT PRE-OPERATING PROCEDURE

SECTION 4.....OPERATOR INSTRUCTIONS

SECTION 5.....ELEC. SWITCHES & CONTROLS OUTSIDE CONTROL BOX

SECTION 6.....ELECTRICAL CONTROLS INSIDE CONTROL BOX

SECTION 7.....PNEUMATIC CONTROLS

SECTION 8.....ADJUSTMENT OF SUB-SYSTEMS

SECTION 9.....ADJUSTMENT OF SEWING HEAD

SECTION 10.....QUICK STOP DRIVE MOTOR

SECTION 11.....GENERAL MAINTENANCE

SECTION 12.....PARTS LIST

SECTION 13.....DIAGRAMS

SECTION 14.....TROUBLESHOOTING GUIDE

SECTION 15.....SUB-SYSTEM TROUBLESHOOTING

CATALOG NO. 501 A

INSTRUCTIONS
FOR
ADJUSTING AND OPERATING
LEFT TROUSER FLY SEWING STATION
2800 E-4

THIRD EDITION

COPYRIGHT 1984
BY
UNION SPECIAL CORPORATION
CHICAGO, IL

RIGHTS RESERVED IN ALL COUNTRIES

Printed in U.S.A.

SECTION 1

GENERAL INFORMATION

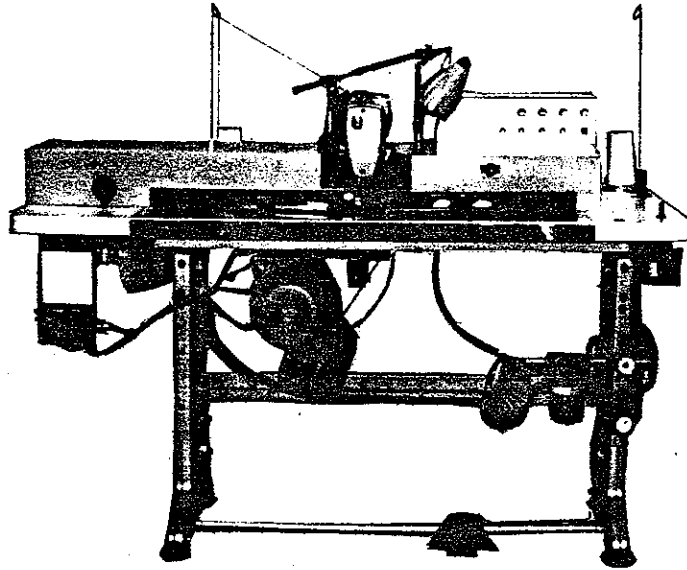

A. OPERATION

Load the fly against garment stops and press the two position foot switch. The clamp will lower; machine will start sewing at slow speed; machine will sew at high speed; machine will slow to a pre-selected medium speed or spot or end of the garment; stop or backtack if required, and cut the threads. The clamp will then lift and return to the starting position.

B. SPECIFICATIONS

1. Mechanical

a. Stitching Profile:

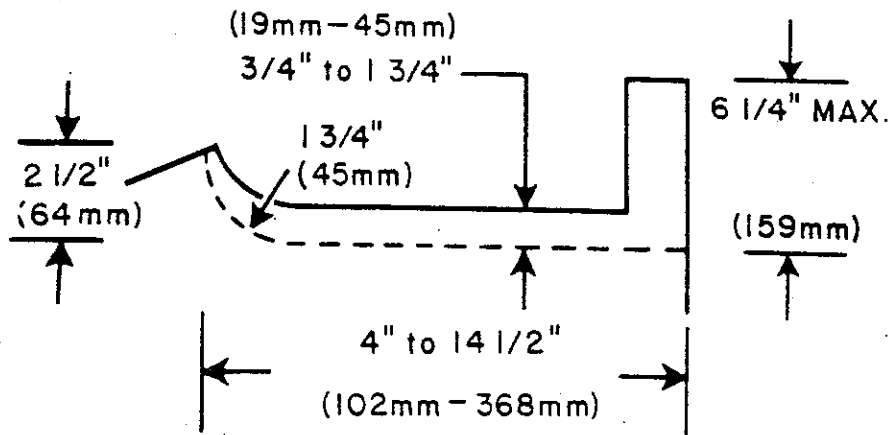

- b. Sewing Head: 63400 LJ
- c. Sewing Speed: 3800 RPM
- d. Sewing Capacity: 1/4 inch (6.4mm)
- e. Stitch Range: 10-18 SPI (2.5mm-1.5mm)
- f. Backtack Range: Start: 2 to 4 Stitches
Finish: 0 to 10 Stitches

2. Electrical

- Operating Voltage: 220V \pm 15%, 3 phase at 6 amps, 60 Hz
220V \pm 10%, 3 phase at 7 amps, 50 Hz
380V \pm 10%, 3 phase at 5 amps, 50 Hz
440V \pm 10%, 3 phase at 4 amps, 50 Hz

3. Pneumatic

- a. Operating Pressure: 80-90 PSI (5.6-6.3 Kg./sq.cm.)
- b. Air Consumption: 2-1/2 cu.ft./min. (80 liters/min.)

4. Physical Information

- a. Required Floor Space: 5' x 5' (1524mm x 1524mm) includes operator space
- b. Unit Size: 54 inches (1372mm) long, 29 inches (737mm) wide,
42 inches (1067mm) high
Sit down operating height adjustable from 28 inches (711mm) to 32 inches (812mm)
Stand up operating height adjustable from 38 inches (965mm) to 42 inches (1067mm)
- c. Shipping Weight: 600 Lbs. (272 Kgs.)
- d. Shipping Container: 52 inches (1320mm) high, 59 inches (1550mm) long, 35 inches (890mm) wide

SECTION 2

INSTALLATION

A. INSPECTION AND UNPACKING.....	2-1
B. CHECK SEWING HEAD.....	2-1
C. CHECK DRIVE CABLE.....	2-2
D. CHECK NEEDLE/CLAMP ALIGNMENT.....	2-2
E. CHECK OIL LEVEL.....	2-2
F. CONNECTING 3 PH. POWER TO THE UNIT.....	2-2
G. CONTROL POWER SUPPLY VOLTAGE.....	2-3
H. CONNECT AIR SUPPLY.....	2-3
I. ADJUST SEWING LIGHT.....	2-4
J. STAND-UP INSTALLATION.....	2-4

INSTALLATION

A. INSPECTION

1. After uncrating the unit, make a visual inspection to check for any obvious damage. Place the unit in the work area.

2. Remove all shipping clamps and tape from the sewing head, clamp, motors, etc.

B. CHECK SEWING HEAD

1. Remove the two covers and stainless steel table top from the unit.

2. Shake the machine back and forth to check for excessive motion of the head in the drip pan base. Movement should not exceed 1/64 inch: more than this amount will cause poor sewing because the needle will not be aligned in center of the clamp.

3. If movement is too great, bed spring is bent. Remove bed spring and press fingers in to hold machine more securely.

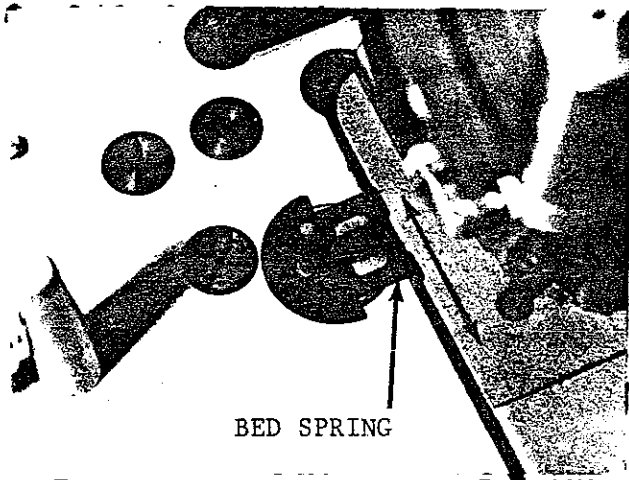

4. Place a straight edge on both the table top and the sewing machine. The sewing machine should be flush with the table top. If machine head is too low, skipped stitches or thread breakage may occur.

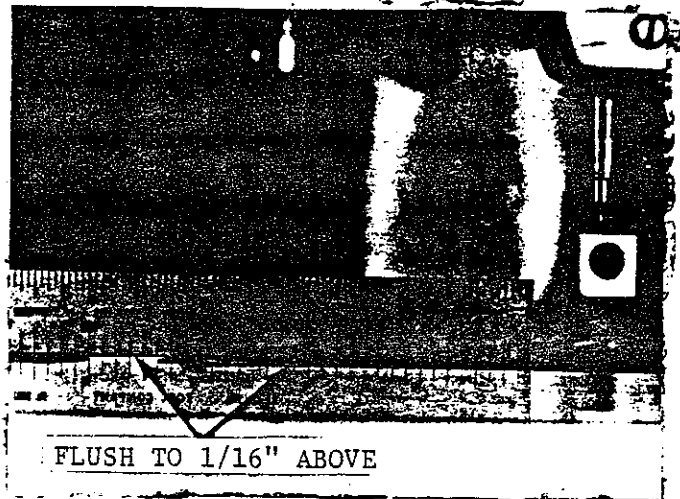

5. To raise machine, loosen lock nut on appropriate height adjusting screw. Adjust screw in or out to raise or lower sewing head to table-top height. Machine should not be any higher than 1/16 inch above table top. Make sure sewing machine is sitting on all four isolator pads and does not rock.

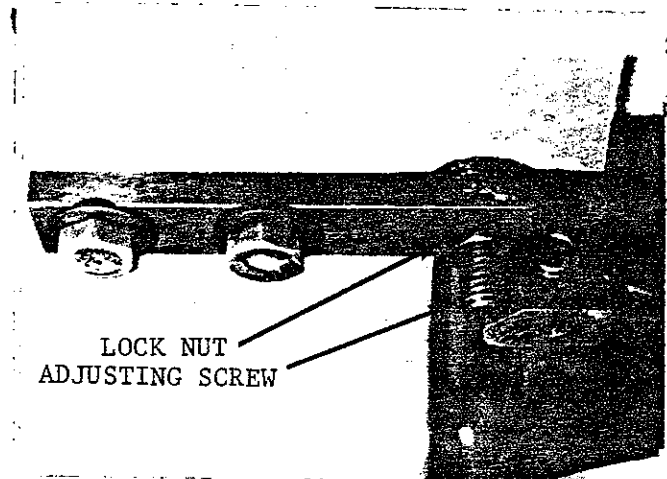

6. It is important to check the machine height after the first month or whenever machine is moved in case the machine settles down on its isolators.

C. CHECK DRIVE CABLE

1. Check that the drive cable is on the pulleys. Cable slack is taken up by the spring loaded self-adjusting idler pulley.

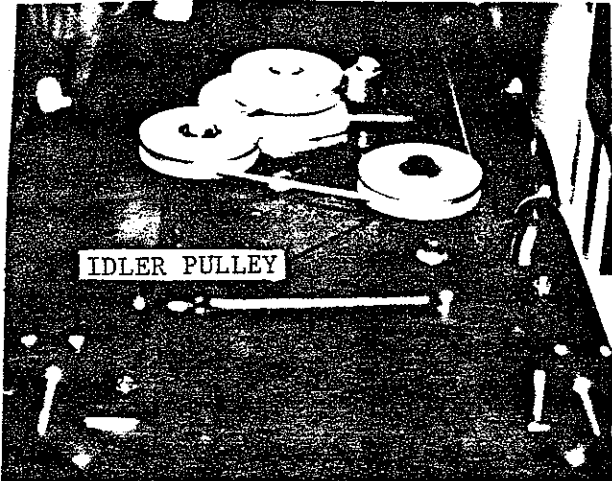

D. CHECK NEEDLE ALIGNMENT

1. Insert new needle 180 SXS 100/040 and position needle bar down.
2. Raise the clamp slightly from the work surface and manually move it through its entire travel by rotating the left horizontal drive pulley. Carefully check that the needle is in the center of the clamp slot for the entire travel. If needle is not in center of slot, refer to page 8-3.

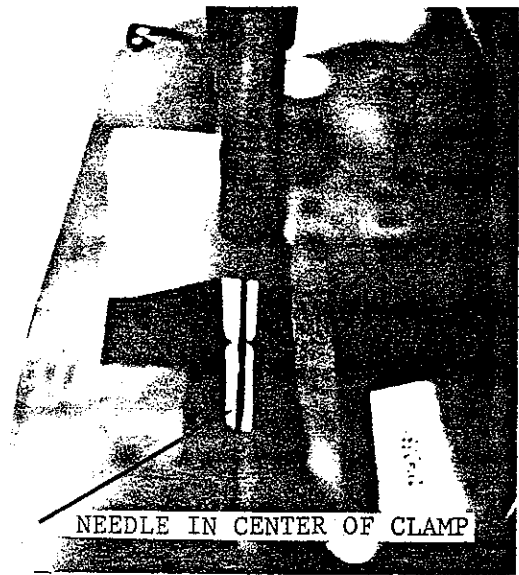
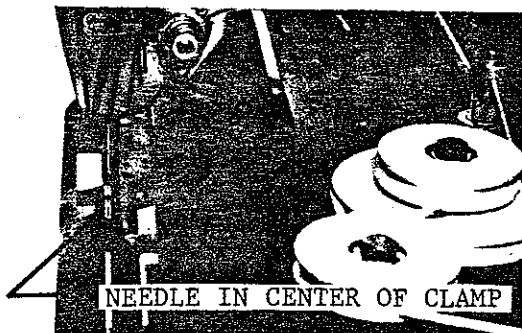

E. CHECK OIL

1. Check the oil level gauge in the sewing head and add oil if necessary.

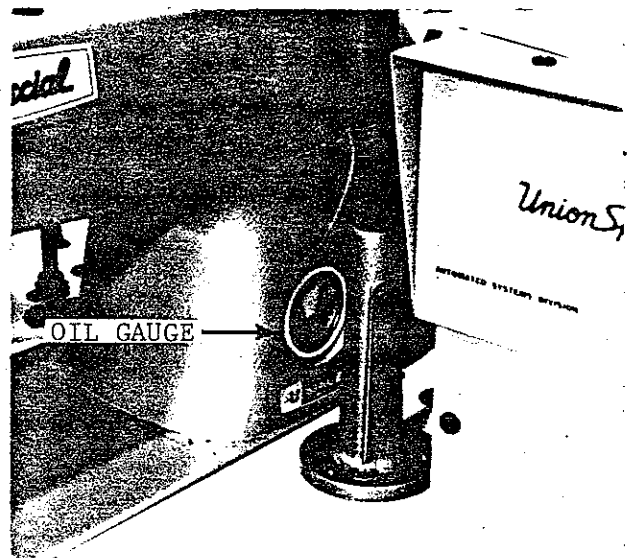

F. CONNECTING 3-PHASE POWER TO THE UNIT

1. Connect 3-phase power to terminals L1, L2, and L3 inside Main Power Switch box. Check for proper rotation as follows:
 - a. Turn Main Power Switch rapidly ON and OFF and observe the rotation of the drive motor fan. Fan should rotate in the clockwise direction.

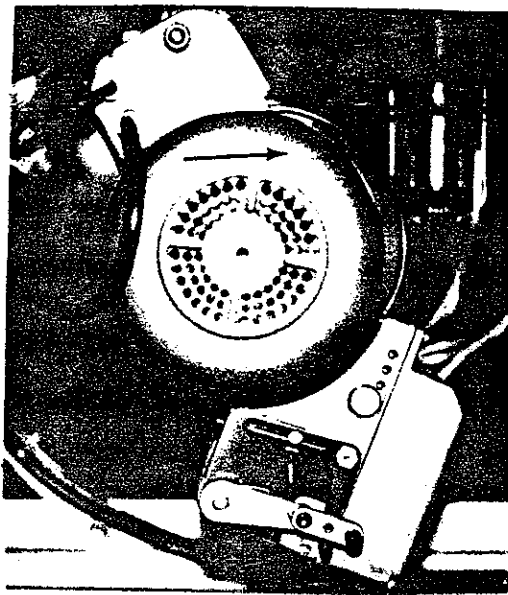

b. If the motor fan rotates in the wrong direction:

- Disconnect electrical supply line plug.
- Interchange phases L1 and L2 inside the Main Power Switch box.

CAUTION

The unit is properly grounded. Your outlet must be grounded to insure adequate protection for the operator and the equipment.

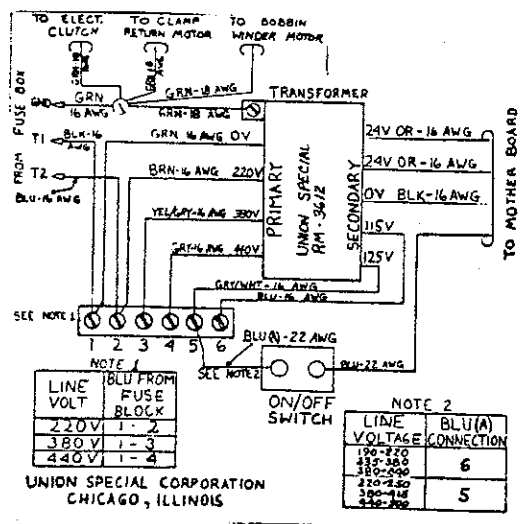

G. CONTROL POWER SUPPLY VOLTAGE

To insure proper operation of the unit, the step down transformer must be matched to the plant line voltage. The step down transformer, RM-3612, is located underneath the electrical control box. The transformer is accessible by removing the rear plate.

1. Using a reliable voltmeter, measure the 3-phase line voltage at the receptacle for the unit.

2. If line voltage is at or above nominal, i.e., 220-250 VAC, 380-415 VAC, 440-500 VAC, connect blue wire to pin 5 on the transformer terminal strip.

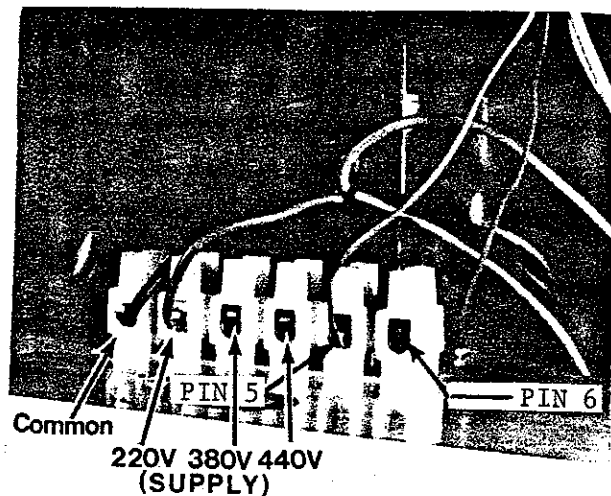

3. If line voltage is below nominal, i.e., 190-220 VAC, 335-380 VAC, 380-440 VAC, connect blue wire to pin 6 on the transformer terminal strip.

H. CONNECT AIR SUPPLY

1. The oil lubricator must be filled with mineral oil before the machine is placed in operation. Union Special specification 174 may be used.

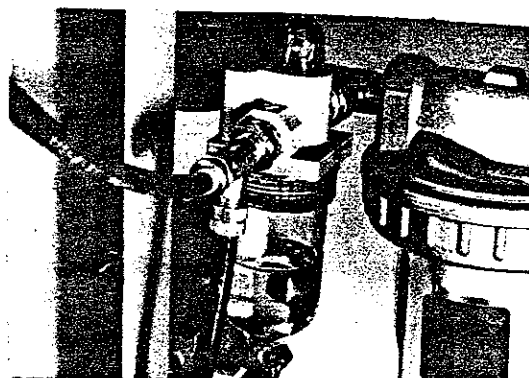

2. Be sure the supply line has been purged of any contaminants and/or moisture before attaching to unit.

3. Connect the air supply line to the unit and adjust the regulator to 45 PSI.

4. Observe the air filter bowl during the first half hour of operation to be sure no appreciable accumulation occurs.

5. The supply filter is equipped with an automatic drain. Make sure filter bowl drains when full. If not, remove and clean thoroughly. Plunger may be clogged preventing free movement.

6. If the accumulation in the filter bowl is not removed, excessive oil and water will build up in the pneumatic control system, eventually causing malfunctions. A considerable amount of time will then be required to drain and clean the system before resuming normal operation.

I. ADJUST SEWING LIGHT

1. Loosen sewing light bracket screws and position sewing light approximately 9 to 10 inches above the table and about 4 inches to the right of needle. Turn light to illuminate NEEDLE area.

2. Tighten sewing light bracket screws to prevent movement of light.

J. STAND-UP INSTALLATION

1. The unit is shipped as a sit down unit (30 inches high); however, it can be converted to a stand up unit (40 inches high) by installing the accessory parts shipped with it: eight table leg extension bars, spacers, bolts, and foot switch conversion parts.

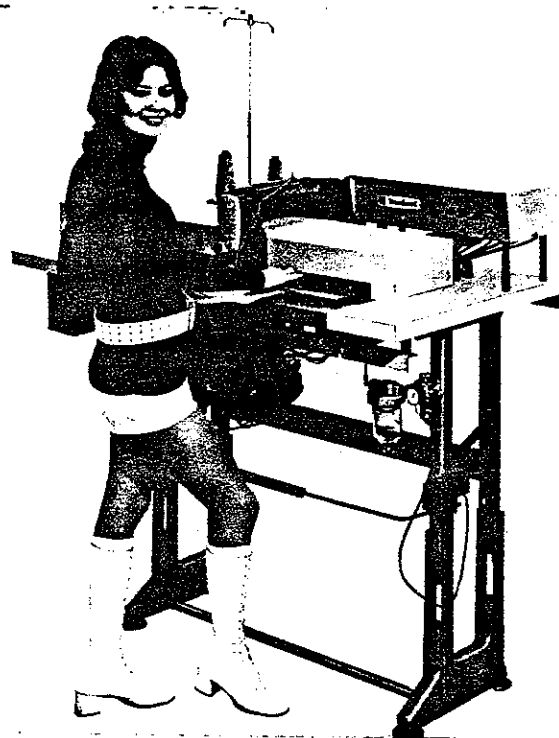

2. Raise the unit approximately 12 inches off the floor and firmly support it. Be sure not to pinch any wires or air tubes. MAKE CERTAIN that the unit will not fall.

3. Remove the lower portion of the table legs by removing the treadle rod and the four bolts from each leg. Remove switch from treadle rod.

4. Assemble the right table leg with the extra long extension, RM-3449, on the outside of the right front leg. Make sure spacers are installed between leg halves.

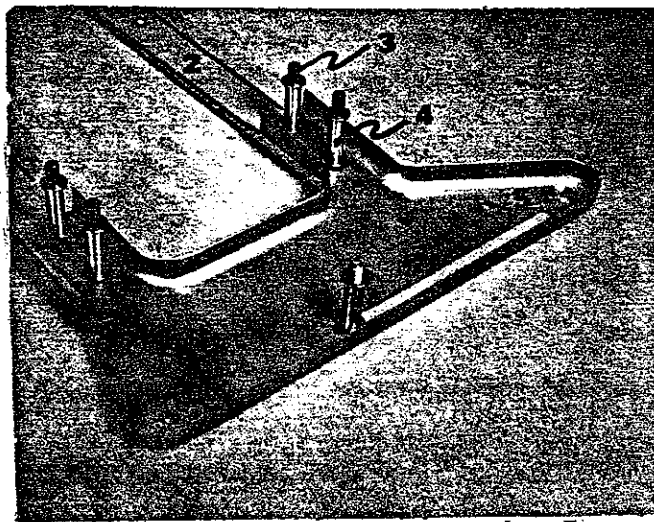

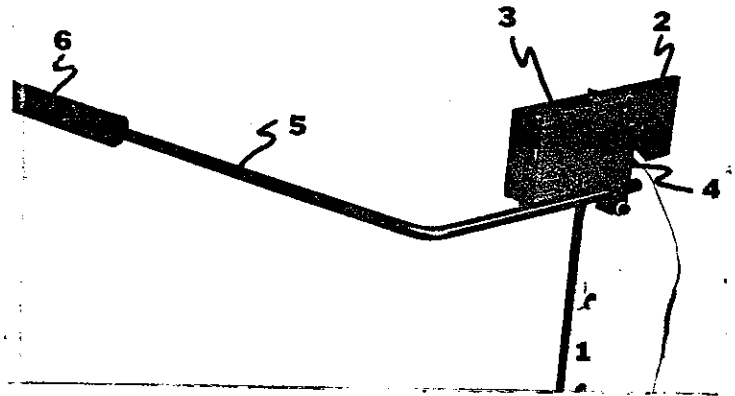
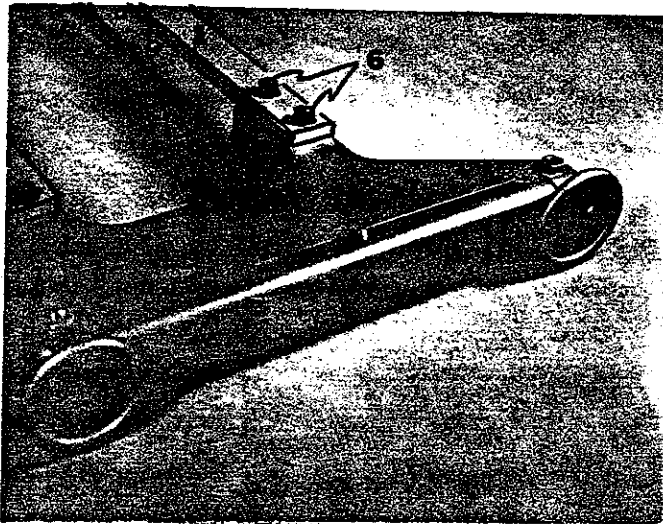

KIT 29480 VY

REF NO	PART NO	DESCRIPTION	AMT REQ
1	RM 3454	Leg Extension	7
2	RM 3449	Outer Right Front Leg Extension	1
3	RM 2827-9	3/16-16 x 3" H.H.S.	16
4	51-214 BLK	Spacers	10
5	21371 WF	Right-hand Side Plate	2
6	652 L-24	Washer	16
	RM 3211-3	3/8-16 Hex Nut	8
7	21371 WE	Left-hand Side Plate	2

REF NO	PART NO	DESCRIPTION	AMT REQ
1	RM 3449	Switch Plate Leg Extension	1
2	RM 3450	Start Switch Plate	1
	RM 3162-6	1/4-20 x 1/2 H.H.S.	2
3	RM 3351	Start Switch Assembly	1
	22652 A-6	8-32 x 3/8 S.H.S.	3
4	RM 3453	Rod Support	1
	22653 B-10	10-32 x 5/8 S.H.S.	2
5	RM 3451	Actuator Rod	1
	RM 3306-2	10-32 x 5/8 S.H.S.	1
6	RM 3452	Rod Sleeve	1

5. Assemble left table leg with the remaining extensions and spacers.

6. Attach the lower assembly with extensions to the legs of the unit. Assemble treadle rod and tighten all bolts.

7. Carefully lower unit to floor.

8. Assemble knee switch actuator using conversion parts. Attach switch to right front leg extension.

SECTION 3

UNIT PRE-OPERATION PROCEDURE

- A. PREPARING UNIT FOR OPERATION.....3-1
- B. SEQUENCE OF OPERATION.....3-1
- C. TIMING CHART.....3-3

UNIT PRE-OPERATING PROCEDURE

A. PREPARING UNIT FOR OPERATION

An understanding of the unit's controls and adjustments is necessary before placing unit into operation. The instructions in this section should be followed in sequence. If the pre-operating procedure has been completed and an individual system still requires further adjustment, refer to the table of contents for additional information on the specific system involved.

1. Set controls as follows:

Main Power Switch	ON
Control Power Switch	ON
Backtack Selector Switch	YES
Threading Switch	OPERATE
Backtack Length Knob	3
Stop Position Knobs 1 & 2	4-1/2
Stop Position Switch	2
Bobbin Winder Knob	3
Main Air Supply	45 PSI
Klipp-It Knife Air Supply	15 PSI

2. Check and adjust the following if necessary:

Photocell Sensitivity	Page 6-1
Quick Stop Synchronizer	" 10-5
Needle/Clamp Alignment	" 8-3

B. SEQUENCE OF OPERATION

The following sequence is with backtacking at the waistband and medium speed for sewing over the waistband.

1. Refer to timing chart. When the unit is in the rest position with both main and control switches ON, the following conditions are in effect.

a. The electric clutch is energized with approximately 90 volts D.C.

b. Solenoid A is de-energized shutting off air to the thread wiper system.

c. Solenoid B is de-energized shutting off air to backtack lever cylinder controlling the reverse cycle.

d. Solenoid C is de-energized. This normally open solenoid supplies air to the clamp lift cylinder (clamp is up), and the presser foot cylinder (presser foot is up).

e. Solenoid D is de-energized shutting off air to the vision flap cylinder, which is retracted to keep the vision flap open.

2. The operator loads the material and depresses the foot switch to engage and close the first position switch FS1. The following occurs:

a. Air wiper blows as solenoid A is energized.

b. Clamp and presser bar drop as solenoid C is energized. When the lifter lever moves, the normally closed clamp interlock switch opens, preparing machine to operate.

c. Vision flap closes as solenoid D is energized.

d. The voltage to the electric clutch remains at the 90 volts dc, preparing clamp to feed.

e. If front backtack is used, Solenoid B is energized placing machine in reverse direction.

3. The foot switch is then depressed further, engaging and closing the second position switch FS2. The following occurs:

a. A time delay control delays machine from going into high speed mode. If front backtack is used, solenoid B is energized during time delay.

b. The machine starts sewing in the low speed mode. If front backtack is used, machine will sew slow speed in reverse direction.

c. The control circuit locks unit into automatic operation so that the voltages to solenoids C and D are held independent of the foot switch.

d. The foot switch can be released at this point. Solenoid A de-energizes when the foot switch is completely released, shutting off the air wiper.

e. After the time delay is timed out, machine will run at high speed. If front backtack is used, solenoid B is also de-energized after time delay allowing machine to sew in forward direction.

4. When the clamp moves the pants panel, exposing the photocell to the machine light at the end of the waistband, two time delays begin simultaneously:

a. Time delay before switching from high speed to medium speed.

b. Time delay before backtacking at waistband.

5. The machine slows to medium speed until the stop position time delay is completed. At the end of this delay, the following occurs:

a. The backtack delay occurs while the machine slows down from medium speed to slow speed.

b. The backtack timer is started.

c. Backtack solenoid B is energized supplying air to the backtack cylinder. This causes the reversing arm on the transmission drive to move, driving the clamp in the reverse direction.

d. The backtack timer times out and needle positioning and trimming occurs.

e. Air supplied to the backtack cylinder is shut off when solenoid B is de-energized causing the reversing arm on the transmission drive to return to the forward position.

f. After a preset time delay to insure completion of position and trimming cycles, Solenoid C is de-energized allowing clamp to raise.

g. Solenoid D is de-energized opening up vision flap.

h. Electric clutch voltage decreases from 90 to 0 volts dc, preparing for clamp return.

i. The clamp return delay begins, providing time for the clamp to raise and the presser bar to retract before the clamp starts its return cycle.

j. When the clamp raises, the clamp interlock switch on the sewing head is engaged by the lifter lever and closes, preparing the control circuit for the next sewing cycle.

k. After the clamp return delay times out, the clamp return motor is activated returning the clamp to the start position.

l. When the clamp returns to the start position, a stud on the left hand drive pulley engages the clamp return limit switch which shuts off power to the clamp return motor and supplies 90 VDC to electric clutch.

6. The unit is now in the rest position ready for the loading of the next panel.

TIMING CHART

Machine is in rest position with both main & control switches on.

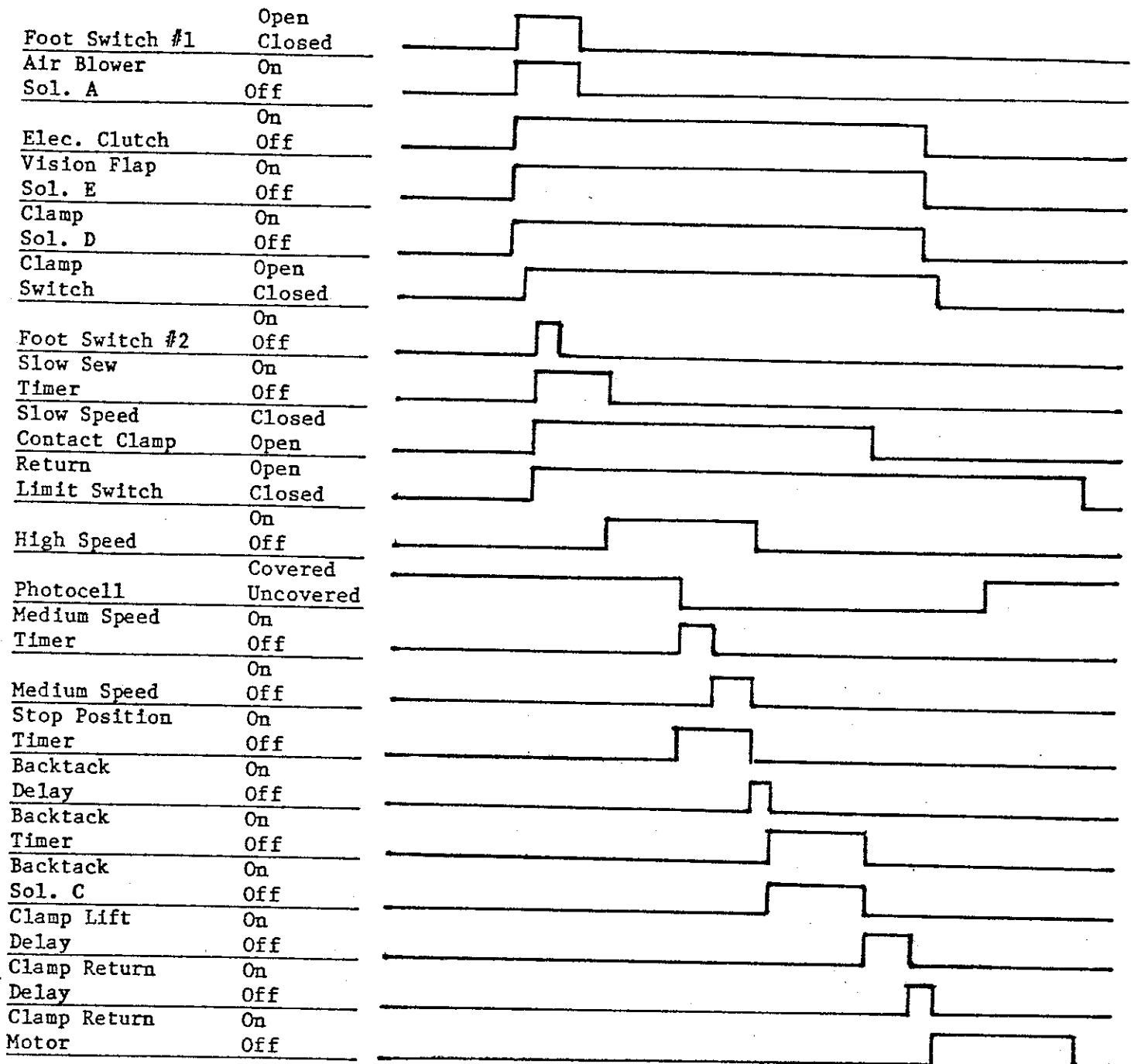

SECTION 4

OPERATOR INSTRUCTIONS

A. STARTING UNIT	4-1
B. CLAMP SWITCH	4-1
C. THREADING	4-1
D. REMOVING THE BOBBIN CASE	4-2
E. WINDING THE BOBBIN	4-2
F. THREADING THE BOBBIN CASE	4-3
G. CHANGING THE NEEDLE	4-3
H. BOBBIN THREAD TENSION	4-3
I. NEEDLE THREAD TENSION	4-3
J. LOADING PROCEDURE	4-4
K. STOP POSITION	4-5
L. BACKTACK LENGTH	4-6
M. OPERATING HINTS	4-6
N. MACHINE CARE CHECK LIST	4-6

OPERATOR INSTRUCTIONS

A. STARTING UNIT

1. Turn on Main Power Switch located on left side of tableboard.

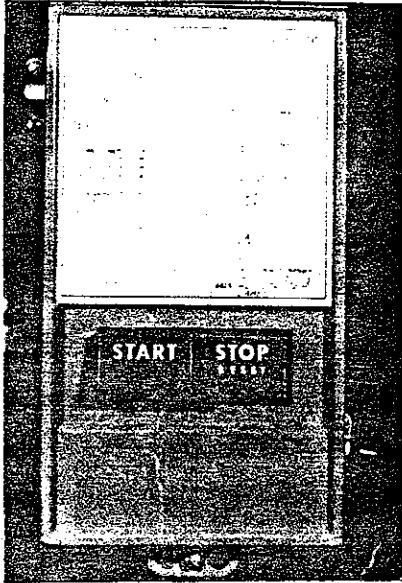

2. Make sure system air pressure is from 45 to 55 P.S.I. The air pressure gauge is located on the right side of the tableboard.

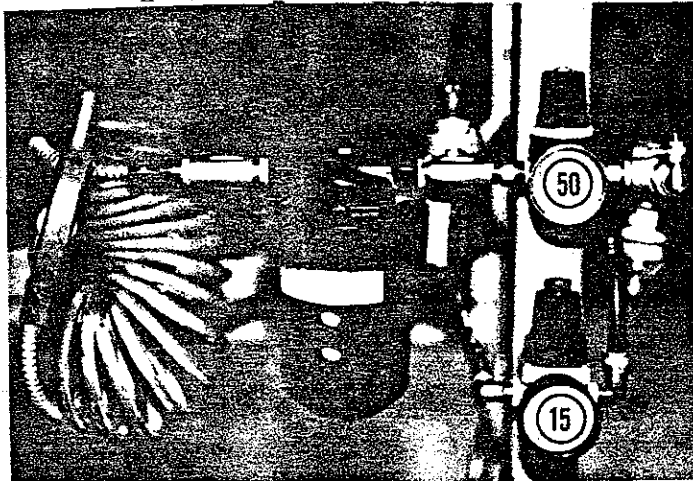

3. Turn on Control Power Switch located on the control panel. NOTE: To avoid damaging circuit board, always turn on Main Power first and then Control Power. When turning off unit, reverse procedure.



CONTROL POWER (
ON



OFF

B. CLAMP SWITCH

The clamp switch is located on the control panel. In the "THREAD" position, the clamp will drop to allow easier access to thread the needle. In the "THREAD" position the foot start switch, if depressed, will not activate the machine. To start the machine, the Clamp Switch must be in the "OPERATE" position.

C. THREADING

The threading diagram below shows where the needle thread passes. Please note that the needle thread passes through the needle eye from front to back. Leave about 1-1/2 inch (38mm) of thread from the needle eye to the free end for best starting appearance. To thread needle, place clamp in THREAD position.

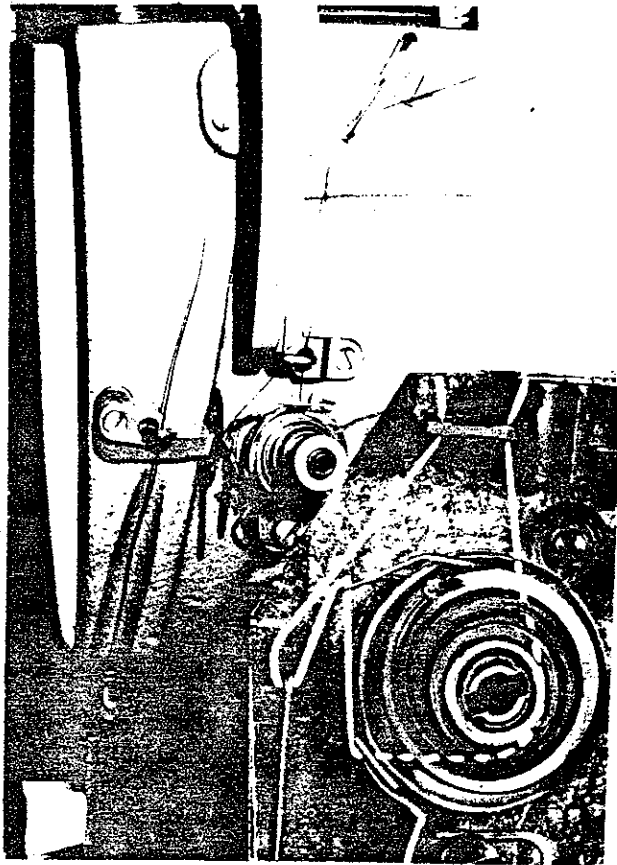

Opening the latch retains the bobbin in the case. When the latch is closed, the bobbin is released and can readily be removed.

E. WINDING THE BOBBIN

1. The bobbin winder is located on the right side of the unit. The button under the table near the bobbin winder starts the bobbin winding cycle.

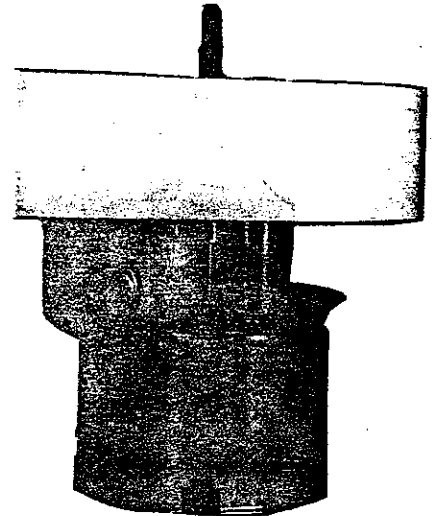

NOTE: If all holes are threaded in the three hole eyelets, needle thread length may be too short. Too short of a needle thread tail will cause the needle to become unthreaded or cause problems on the starting stitches.

To operate bobbin winder, place bobbin on the bobbin winding stud and wind a few turns of thread counterclockwise. Then momentarily depress the bobbin winder start button and the bobbin winder will start the winding cycle.

D. REMOVING THE BOBBIN CASE

To remove the bobbin case, open the bobbin case latch and pull the bobbin case out of the hook.

2. The bobbin winding cycle will automatically turn off after a pre-selected time. The time the bobbin winder stays on (fullness of bobbin) is adjustable by the bobbin winder control on the control panel.

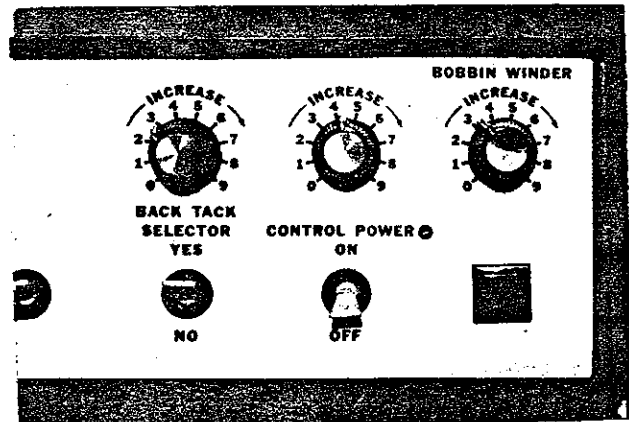
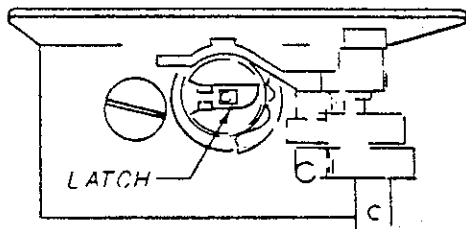

Turning the bobbin winder control clockwise (higher number) increases the amount of thread on the bobbin.

F. THREADING THE BOBBIN CASE

Place the bobbin in the bobbin case. Draw the bobbin thread through the diagonal slot in the bobbin case under the tension spring and into the self-threading eyelet in the bobbin case. The bobbin should rotate counterclockwise.

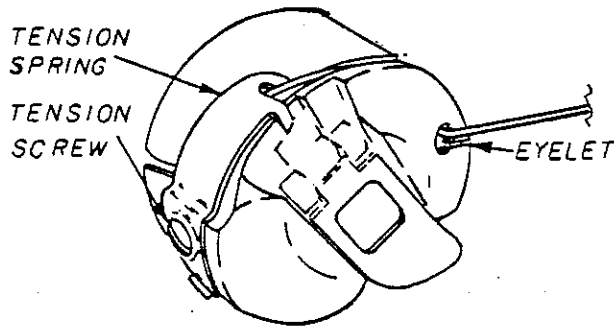

NOTE: If the eyelet is not threaded, the bobbin thread will not be cut.

G. CHANGING THE NEEDLE

Insert the needle into the needle bar as far as it will go with the LONG GROOVE facing the OPERATOR. This groove must face directly in front. If the needle groove is facing the operator at an angle, sewing problems will occur.

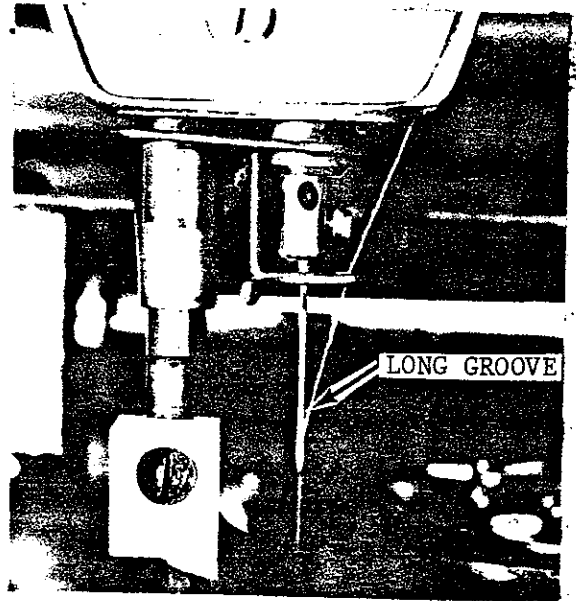

H. BOBBIN THREAD TENSION

The tension on the bobbin case is applied by means of a screw which regulates the tension spring pressure. Turning the tension screw clockwise increases the bobbin thread tension.

I. NEEDLE THREAD TENSION

The needle thread tension is adjusted by turning the tension regulating nut.



Turning the nut in a clockwise direction increases the tension while counterclockwise decreases it.

J. LOADING PROCEDURE

1. When the unit is ready for operation, the clamp will be at the extreme right end of its travel in a raised position. The vision flap is open for better visibility to position the work.

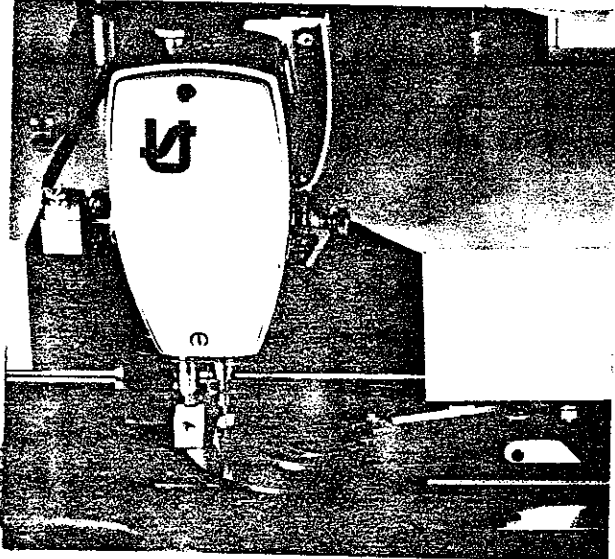

2. Place the left fly under the clamp with the zipper facing down. Be sure that the edge of the material is just covering the needle hole in the throat plate. NOTE: If using front backtack, the fly should be loaded further in past the needle hole to compensate.

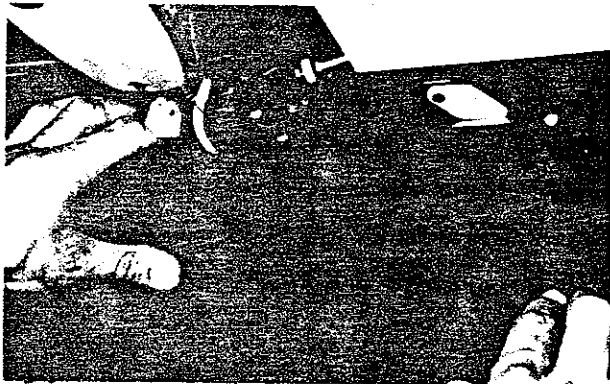

3. Hold the fly against the tabletop with the forefinger of the left hand about 1 inch (25mm) to the left of the starting point or just enough to clear the clamp when it lowers.

4. Hold fly with thumb of right hand at the bottom of the waistband and approximately 2 inches (50mm) from the front edge.

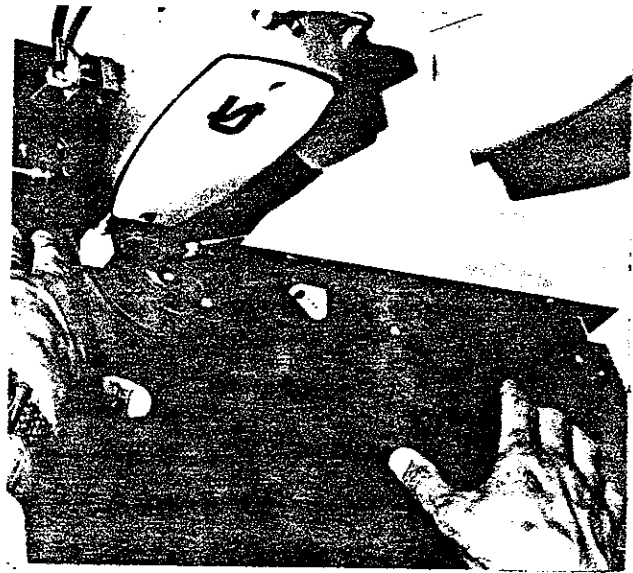

5. Pivot work by sliding right hand toward the clamp. Hold front edge of fly inside clamp with middle finger straddling the clamp.

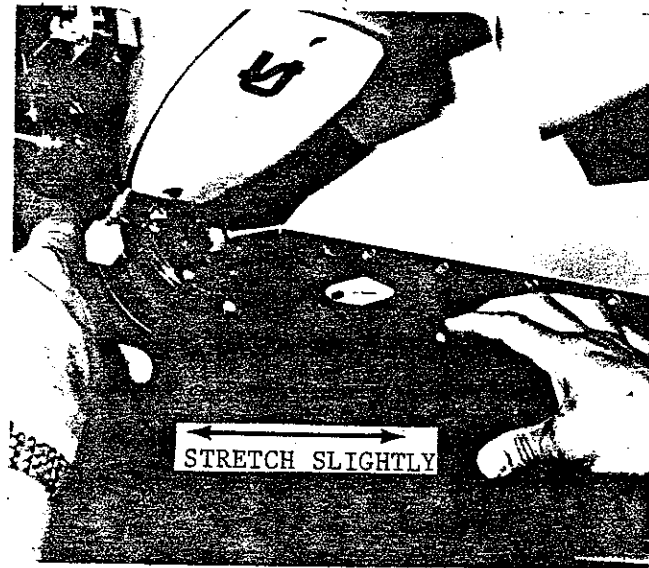

6. Stretch the material slightly by holding the left hand stationary and moving the right hand to the right. Keep fingers clear of underside of clamp.

7. Depress the foot switch to the first position to begin. This will blow the needle thread from under the clamp, close the vision flap, lower clamp and presser bar clamp block. Remove hands and check position of garment. If garment is not loaded properly, release foot switch. Clamp will raise and garment can be repositioned.

NOTE: To prevent the needle thread from being held by the clamp, the needle thread tail must not be on top of material at the start of the fly. It is important, therefore, that the operator load the machine straight in. This prevents the needle thread from being held by the clamp at the start of sewing.

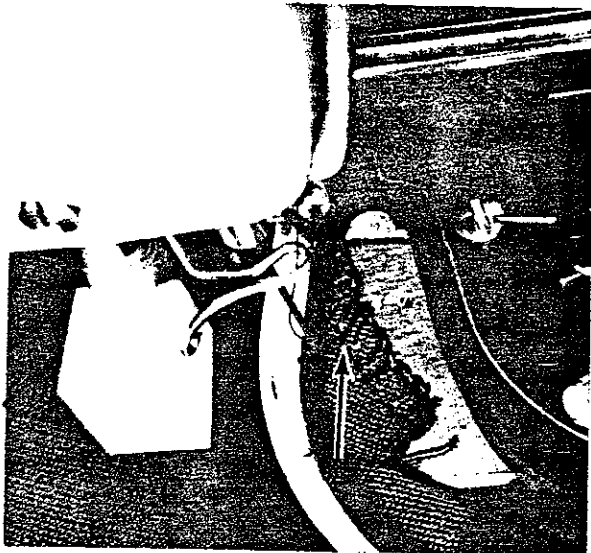

8. When the garment is properly inserted and held by clamp, depressing foot switch further to second position will start the automatic sewing cycle. Foot switch should now be released. The machine will sew, complete its positioning and trimming cycle, and return to the starting position.

NOTE: Do not hold or pull material during sewing. This may cause damage to rubber on clamp.

K. STOP POSITION

1. The stop position adjustments are located on the control panel. These adjustments determine where the sewing machine will stop in relation to the waistband edge.

2. There are 2 stop position adjustments with a selector switch. This selector switch enables the operator to switch stopping positions without adjustments. If the selector switch is in STOP POSITION 1, the STOP POSITION 1 adjustment controls the stopping position. If the selector switch is in STOP POSITION 2, the STOP POSITION 2 adjustment controls the stopping position.

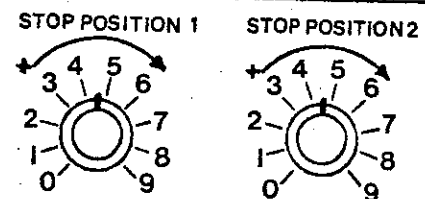

3. STOP POSITION 2 has a resistor added for a longer time delay needed when sewing with a medium speed over the waistband. Therefore, STOP POSITION 1 is for sewing WITHOUT MEDIUM SPEED and STOP POSITION 2 is for sewing WITH MEDIUM SPEED.

4. If in STOP POSITION 1 the machine stops past the waistband, turn the STOP POSITION 1 knob counterclockwise a half number. Sew next fly and check stop position. If the machine still stops past the waistband, continue to turn knob counterclockwise until proper stop position is obtained. If machine stops before desired position, turn knob clockwise (higher number). STOP POSITION 2 works only if the selector switch is in the #2 position. STOP POSITION 2 is adjusted in the same manner as STOP POSITION 1. In no way does STOP POSITION 1 affect STOP POSITION 2.

L. BACKTACK LENGTH

1. If backtacking at the waistband is NOT required, place the BACKTACK SELECTOR switch in the NO position. The backtack selector switch is located on the control panel.

NOTE: In the NO position, there is also NO FRONT BACKTACK. If front backtack is desired but none at waistband, place BACKTACK switch to YES and adjust BACKTACK LENGTH to 0.

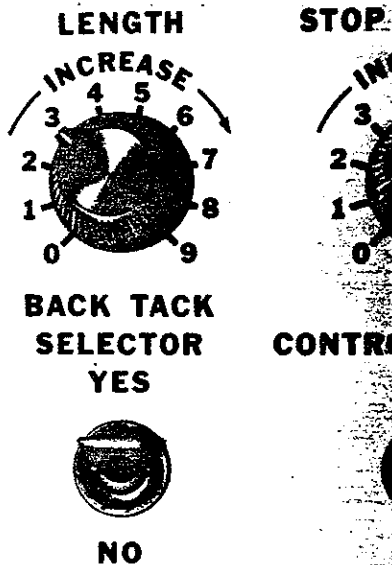

2. If backtacking at the waistband IS REQUIRED, place the BACKTACK SELECTOR switch in the YES position.

3. The amount of backtack stitches at the waistband is controlled by the BACKTACK LENGTH adjustment knob on the control panel. Turning the knob clockwise (higher number) increases the amount of stitches. Turning the knob counterclockwise (lower number) decreases the amount of backtacks.

M. OPERATING HINTS

1. Be sure that only a slight amount of stretch is applied to the fly and held until the clamp comes down. Material should lie flat without being distorted.

2. Do not pull garment once the clamp is down. Do not assist material in any way until after the cycle is completed.

3. Do not change position of machine light. Changing light position will affect the automatic stop position function.

If the machine continues to sew past the waistband to the end of the clamp, turn off control power and notify mechanic.

5. If machine skips stitches or breaks thread, check needle; check for proper threading.

6. If bobbin thread is not cut at end of cycle, check threading of bobbin case.

7. If the bobbin appears to be too full and you want to shut off the bobbin motor, either hold bobbin push button in and remove bobbin or turn off Control Power switch.

N. MACHINE CARE CHECK LIST

1. DAILY:

a. REPLACE NEEDLE first thing before operating.

b. CHECK MACHINE OIL LEVEL

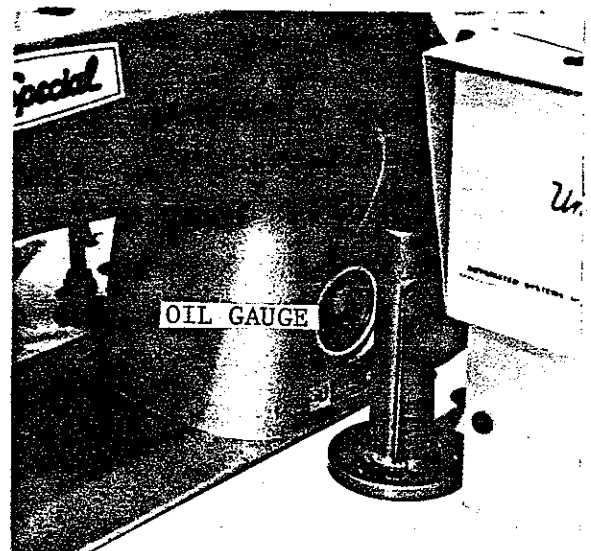

c. CHECK OIL LEVEL IN AIR
LUBRICATOR



If either oil level is low,
NOTIFY MECHANIC AT ONCE.

2. MID-DAY and END of DAY:

With bobbin case removed,
blow lint from hook area with air
hose.

SECTION 5

ELECTRICAL SWITCHES AND CONTROLS OUTSIDE CONTROL BOX

A. MAIN POWER SWITCH.....	5-1
B. CONTROL POWER SWITCH.....	5-1
C. STARTING SWITCH.....	5-1
D. THREADING SWITCH.....	5-2
E. BACKTACK SELECTOR SWITCH.....	5-2
F. BACKTACK LENGTH CONTROL.....	5-2
G. STOP POSITION SELECTOR SWITCHES.....	5-2
H. STOP POSITION CONTROLS.....	5-2
I. BOBBIN WINDER CONTROLS.....	5-3
J. START INTERLOCK CLAMP SWITCH.....	5-3
K. SAFETY SWITCHES.....	5-4
L. CLAMP RETURN CONTROL.....	5-4
M. EMERGENCY STOP SWITCH.....	5-5

ELECTRICAL SWITCHES AND CONTROLS OUT-SIDE CONTROL BOX

A. MAIN POWER SWITCH

The Main Power Switch is located under the left hand side of the table. This switch controls the power to the drive motor, needle positioner, trim cycle, machine light, and the control box. This switch also acts as a circuit breaker in the event of a short circuit or overload condition. To reset switch in such an event, first push stop button and then start button.

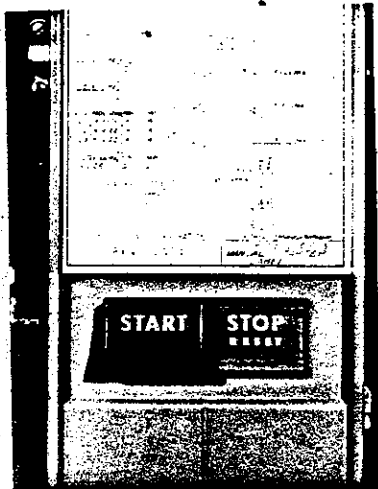

B. CONTROL POWER SWITCH

The Control Power Switch, on the face of the control box, controls all functions of the unit except the drive motor, needle positioning, trim cycle, and machine light. When in the ON position, the red pilot light on the control panel will turn on.

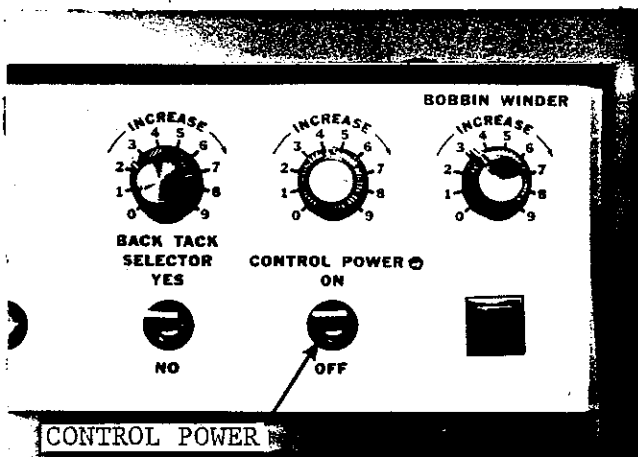

NOTE: To avoid possible damage to circuit boards, it is important to follow the following switching sequence:

- TURN ON:
1. MAIN POWER
 2. CONTROL POWER

- TURN OFF:
1. CONTROL POWER
 2. MAIN POWER

C. STARTING SWITCH

The Starting Switch, on treadle rod, is a two position foot switch. Depressing the switch to the first switch position causes the clamp to lower on the material. Further movement causes the machine to lock into its automatic cycle mode. The switch can be adjusted both left and right by loosening the pipe clamp on the switch bracket and sliding the switch assembly to the position required. The forward or backward adjustment is made by moving the entire treadle rod in desired direction (the same way as on standard tabling).

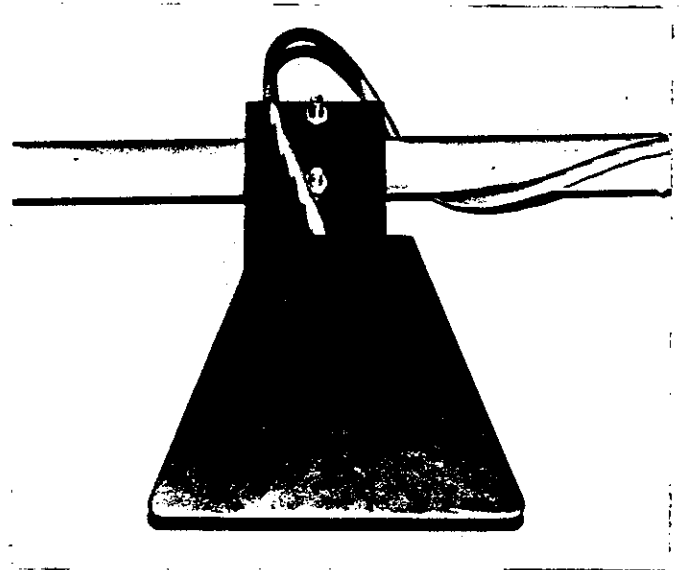

NOTE: This switch can also be converted to a knee switch (refer to page 2-5)

D. THREADING SWITCH

Threading Switch (clamp lift switch) on control box is used to lower the clamp so that the needle is better exposed for threading. After threading, the switch should be moved to the Operating position so that the clamp will lift, ready for the insertion of the next garment piece. If the switch is left in the threading position, the clamp remains down and the return motor is inactivated. NOTE: Unit will not sew if clamp is in the threading position.

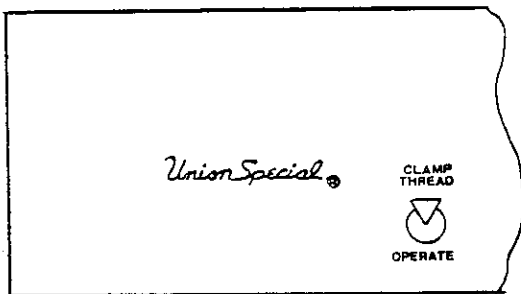

E. BACKTACK SELECTOR SWITCH

Backtack Selector Switch, on control panel, just left of the control power switch. When the backtack selector switch is in the NO position, the unit will topstitch a left fly without backtacking at the waistband end. If the backtack selector switch is in the YES position, the unit will topstitch a fly with a backtack at the end of seam.

NOTE: In the "NO" position there is also NO FRONT BACKTACK. If FRONT BACKTACK is desired but no backtack at waistband, place BACKTACK switch to YES and adjust BACKTACK LENGTH control to 0.

F. BACKTACK LENGTH CONTROL

This control on the face of the control box just above the Control Power switch controls the number of stitches in the backtack sewing operation. Turning the knob counterclockwise will reduce the number of stitches in the backtack sequence: clockwise will increase the number of stitches.

G. STOP POSITION SELECTOR SWITCH

The stop position selector switch is located on the control box. This switch enables the operator to select one of two pre-set stop positions.

H. STOP POSITION CONTROL

1. This control is part of the delay function in the photo-electric sensing system and consists of two sets of two potentiometers on the face of the control box. They are used to adjust the position of the final stop-trim cycle or the beginning of the backtack cycle, depending upon the position of the Backtack Selector switch. The stop position control adjustment determines where the sewing machine will stop in relation to the waistband edge.

2. The fine adjustment knobs are labeled STOP POSITION 1 and STOP POSITION 2. The coarse adjustment potentiometers are accessible by screwdriver through a small hole just to the lower right of the respective stop position control knob. The STOP POSITION 1 potentiometers are activated only when the STOP POSITION SELECTOR SWITCH is in the 1 position. The selector switch must be in the 2 position to activate the STOP POSITION 2 potentiometers. In no way does the Stop Position 1 adjustment affect Stop Position 2.

I. BOBBIN WINDER CONTROLS

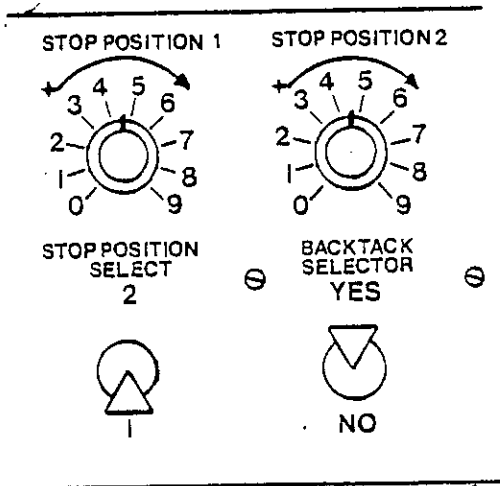

3. Place Stop Position Selector Switch in 1 position. Adjust the coarse potentiometer with the fine adjustment knob set at 4-1/2 on the dial face. Take a 12 inch (30 cm) double ply square piece of material and fold one end to simulate a waistband. Mark on the material where the machine should stop stitching in relation to the waistband end. Sew on material making sure the simulated waistband end is square.

4. If machine stops before mark on material, rotate coarse potentiometer adjusting screw clockwise until machine stops on mark. If machine runs beyond mark, rotate coarse pot counterclockwise until machine stops ON mar. All further adjustments should be made with the STOP POSITION 1 control knob.

5. If another style pant requires a different stop position, repeat steps 3 and 4 with the STOP POSITION SELECTOR switch in the 2 position and use the STOP POSITION 2 controls.

6. After the stop positions are set, the operator need only select the required position for a different stop position.

1. The bobbin winder is on the right side of the unit. It is controlled by an electronic timing circuit. The potentiometer on the control box face adjusts the fullness of the bobbin by controlling the time of bobbin filling. If turned counterclockwise, less thread will be put on the bobbin, while clockwise puts more thread on the bobbin.

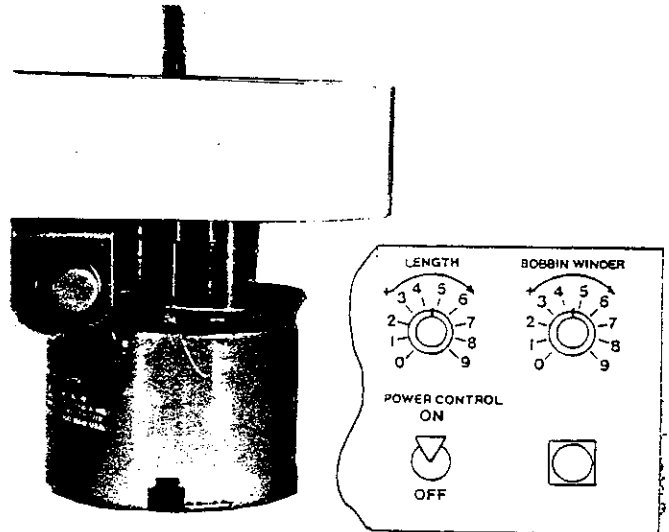

2. The red button under the table near the bobbin winder starts the bobbin winding cycle. To operate bobbin winder, place bobbin on the bobbin winding stud and wind a few turns of thread counterclockwise. Then momentarily depress the bobbin winder start button and the bobbin winder will start the winding cycle. After the pre-selected time, the bobbin winder will stop and the bobbin will be full. If not, the adjustment can be made on the control knob.

J. START INTERLOCK CLAMP SWITCH

1. Start interlock clamp switch, on side of machine, is actuated by the presser lift cylinder. It is used as an interlock to insure that the machine will not sew when the clamp is up and that the clamp will be down before the machine starts automatic mode.

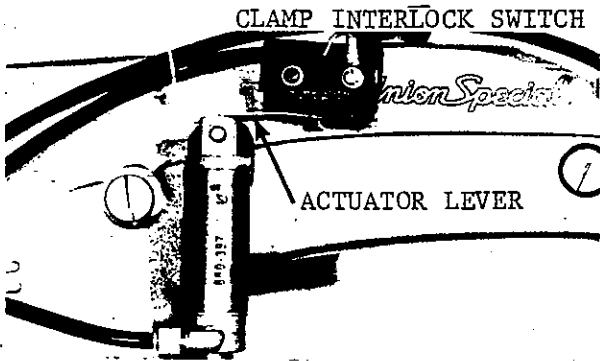

2. If switch actuator lever is bent, machine will not sew when foot switch is in the second position. A misadjusted switch could also cause the clamp to lift and the machine to position and trim when it hits a thicker waistband. If any of the above occurs, carefully bend down the switch actuator lever.

K. SAFETY SWITCHES

1. Safety switches on left end of table board at the extreme end of clamp travel, are used to automatically stop and reset the sequence of the machine in the event of a photocell or automatic stop control failure. They are actuated by the carriage when it reaches the extreme left end of its travel.

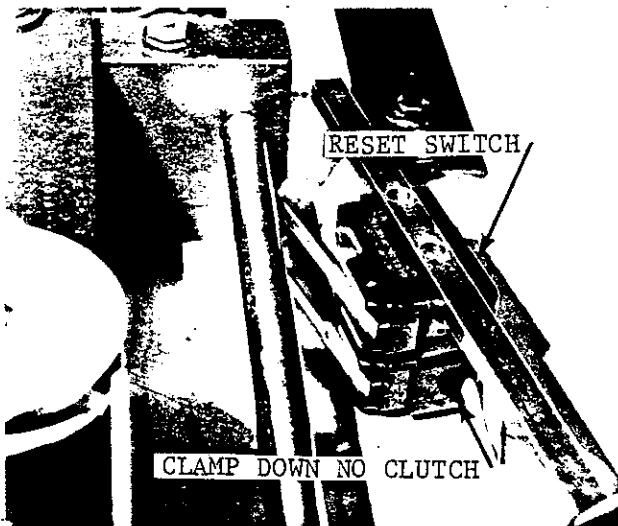

2. The lower switch keeps the clamp from lifting and, at the same time, de-activates the clutch cylinder so that the machine stops and no damage occurs to the clamp.

3. The upper switch automatically resets the control circuit so that the machine will return to the proper sequence for insertion of the material.

L. CLAMP RETURN CONTROL

The speed of the carriage during the return stroke is controlled by the gear motor on the left hand side of the unit. The speed is not adjustable, and the only adjustment which may have to be made is in the operation of the shut-off switch, which is activated by the bumper on the underside of the drive pulley. This switch shuts off the power going to the return motor and energizes the electric clutch. If the motor, when it reaches the extreme right end of the travel, begins to oscillate, the actuating lever of the switch has to be rebent to engage the bumper sooner.

NOTE: If not backtacking at the start of the fly, it may be necessary to mount the clamp return switch on the front two holes of the mounting bracket. This will enable the clamp to stop in the curve.

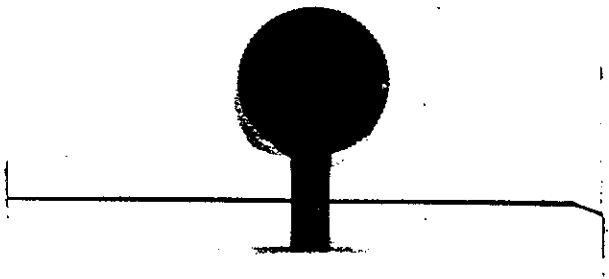

M. EMERGENCY STOP SWITCH

The Emergency Stop Switch is located on the right cover of the machine. When the red push button is pressed, the machine will stop sewing, position, trim, and the clamp will left and return to the start position. The switch button remains in the In position and must be pressed again to release and be in the Run position. If the operator tries to start the machine with the emergency stop switch in, the clamp will lower but the machine will not sew.

SECTION 6

ELECTRICAL CONTROLS INSIDE CONTROL BOX

A. PHOTOCCELL SENSITIVITY ADJUSTMENT.....	6-1
B. BACKTACK START SELECTOR SWITCH.....	6-3
C. WAISTBAND HIGH/LOW SPEED BACKTACK SWITCH.....	6-3
D. SLOW SPEED START STITCH ADJUSTMENT.....	6-3
E. CLAMP LIFT DELAY.....	6-3
F. BACKTACK DELAY.....	6-4

ELECTRICAL CONTROLS INSIDE CONTROL BOX

A. PHOTOCELL SENSITIVITY ADJUSTMENT

1. The photocell, located 4-1/2 inches to the right of the needle, senses the waistband edge of the garment and initiates medium speed activation, stopping, and backtacking sequences.

2. Although there is only one photocell, there are two photocell sensitivity adjustments. The first adjustment is made inside the RM-4372 Quick Stop Motor Control Panel. This adjustment is the actual sensitivity adjustment of the photocell. A processed high or low signal is sent from the motor control panel to the RM-3619 U logic board when the photocell is covered or uncovered. The logic board sensitivity adjustments are not as critical since it is receiving either a high or low signal from the Motor Control Panel and not the photocell.

3. To set sensitivity:

- a. Turn ON MAIN POWER switch ONLY.
- b. Adjust the sewing machine light so that the center of the light bulb is 4 inches (10cm) to the right of the sewing head and 9 to 10 inches (22 to 25cm) above the table top. Direct the light to shine on the NEEDLE AREA.

c. Remove the plastic cover to the Quick Stop Motor Control panel to expose the photocell sensitivity adjustment and red indicator light (L.E.D.).

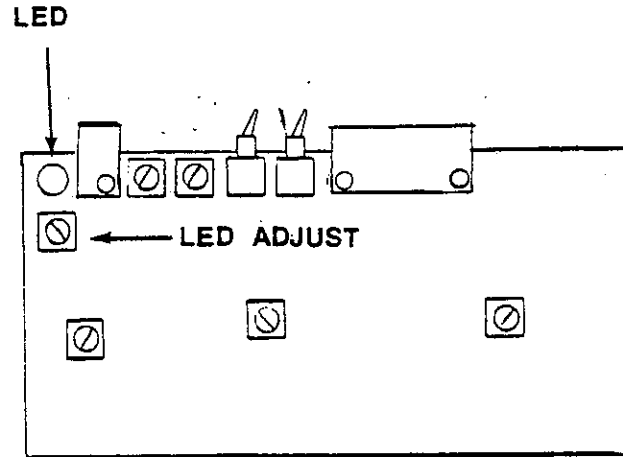

d. With control power OFF, move the clamp to its leftmost position to expose the photocell.

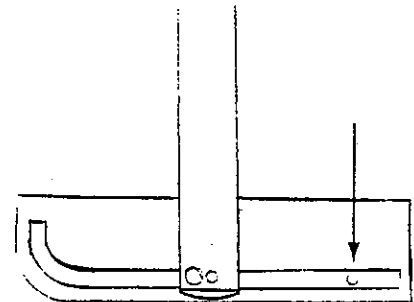

e. Cover photocell with a single ply of the thinnest material to be sewn. Turn Photocell Adjust potentiometer (located directly under L.E.D. CLOCKWISE until the L.E.D. goes off.

CAUTION: Extreme care must be exercised when adjusting the small screw type potentiometers. Use only a small screwdriver and never force the screw adjustment past its stop.

f. Slowly turn Photocell potentiometer COUNTERCLOCKWISE until the L.E.D. turns ON. Uncover and cover the photocell with the material making sure the L.E.D. corresponds by turning off and on.

g. Remove the main control box cover exposing the logic board. Turn potentiometers A and B to extreme CLOCKWISE position.

NOTE: Potentiometer B must always be in its extreme clockwise position and should not be adjusted.

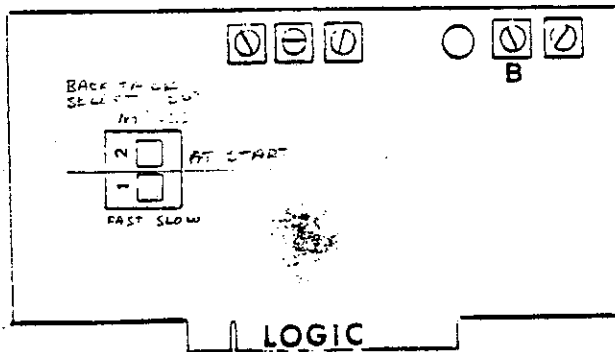

h. Unplug the two BLACK plastic quick disconnect connectors going to the Quick Stop motor control panel to cause machine to sew only at slow speed.

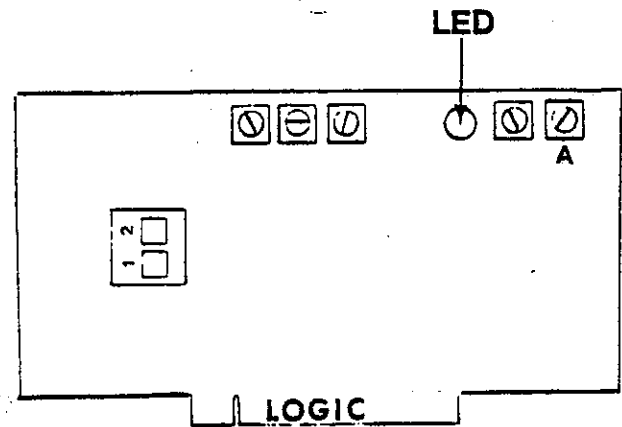

i. Turn ON Control Power switch and load and sew a scrap of material. Notice that the red L.E.D. on the logic board is lit.

j. Let the machine run until the photocell is fully exposed. Slowly turn Pot A COUNTERCLOCKWISE until the red L.E.D. turns off. The machine will stop, position, trim, and the clamp will return to the home position.

k. Connect the black plastic quick disconnects, Quick Stop control panel cover, and main control panel cover.

l. Operate the machine in a normal manner using a single layer of thin pants material. Sew scrap material several times noting the stopping location. If stopping is within + one stitch, the electric eye circuit can be considered properly calibrated. If stopping is not consistent, repeat adjusting procedure making sure photocell light is bright enough and does not flicker.

B. BACKTACK START SELECTOR SWITCH

Machines and RM-3619 U Logic Boards are shipped with the top switch (marked 1) in the left position. With the top switch on the Logic Board in the left position, the starting slow sew stitches are in the forward direction. To backtack at the start of the fly, remove the plastic switch cover on the Logic Board and slide the top switch to the right. In the right hand position, the machine will sew slowly in the reverse direction at the start. NOTE: The Backtack Selector Switch on the Control Panel must be in the YES position to backtack at the start of sewing.

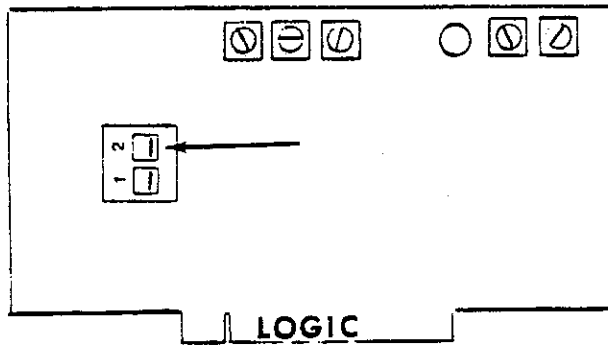

C. WAISTBAND HIGH/LOW SPEED BACKTACK SWITCH

Machines and RM-3619 U Logic Boards are shipped with the lower switch (marked 1) on the Logic Board in the right hand position. In the right hand position, the machine will backtack slowly at the finish.

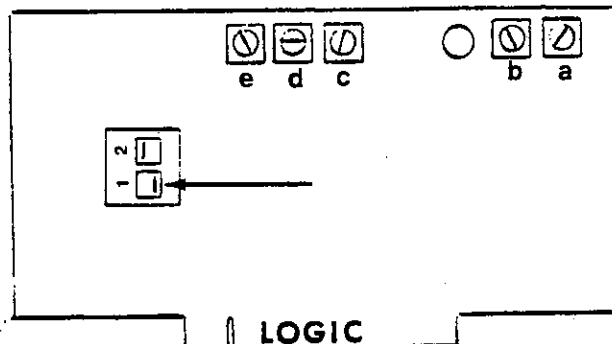

To backtack at high speed at the finish (waistband), remove the plastic switch cover on the Logic Board and slide the lower switch to the left. NOTE: Backtack length adjustment on Control Panel must be adjusted when switching speed of backtack at waistband. If needle heat or thread breakage occur during backtack, slow speed backtack is recommended. Slow speed backtack at waistband will prolong the life of the Zero-Max transmission.

D. SLOW SPEED START STITCH ADJUSTMENT

The machine starts sewing in slow speed to pick up the first stitches. Depending on the position of the backtack start selector switch on the Logic Board, the slow speed stitches may either be in the forward or reverse direction. The number of slow speed starting stitches is controlled by potentiometer C on the Logic Board. Turning potentiometer C clockwise INCREASES the amount of slow sew starting stitches while counterclockwise decreases the amount of stitches. Normally, 3 to 4 stitches are all that are required to insure pick up of the first few stitches. NOTE: If machine backtacks at start more than 4 backtack start stitches, it will cause clamp return switch bumper on return pulley to bottom out on switch bracket. This may cause excessive wear on clamp drive mechanism.

E. CLAMP LIFT DELAY

Potentiometer D on the Logic Board controls the time delay before the clamp lifts. Adjust potentiometer D so that the clamp remains down during the ENTIRE TRIMMING operation. If the clamp lifts during the trimming operation, the threads may not be cut consistently by the Klipp-It or, in extreme cases, the needle bar will hit the clamp. By turning this pot CLOCKWISE, the delay time between the trimming operation and the clamp lifting INCREASES.

F. BACKTACK DELAY

The backtack delay potentiometer E on the Logic Board delays when the backtack cylinder is energized at the waistband end to prevent shifting while sewing at high or medium speed. This potentiometer is FACTORY SET and MUST NOT BE ADJUSTED.

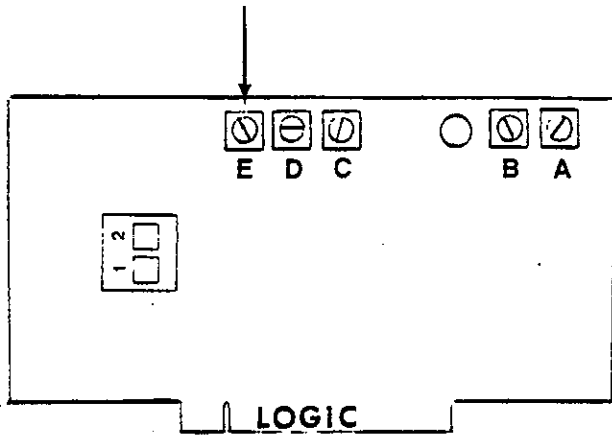

SECTION 7

PNEUMATIC CONTROLS

A.	SYSTEM PRESSURE REGULATOR AND GAUGE.....	7-1
B.	PNEUMATIC OILING SYSTEM.....	7-1
C.	AIR FILTERS.....	7-2
D.	THREAD TRIMMER SYSTEM PRESSURE REGULATOR & GAUGE.....	7-2
E.	THREAD TRIMMER SPEED CONTROL.....	7-2
F.	THREAD WIPER CONTROL.....	7-3
G.	CLAMP LIFT CONTROL.....	7-3
H.	PRESSER BAR CONTROL.....	7-3
I.	VISION FLAP CONTROL.....	7-3
J.	BACKTACK CONTROL.....	7-3

PNEUMATIC CONTROLS

A. SYSTEM PRESSURE REGULATOR & GAUGE

1. The unit requires a minimum air supply of 80-90 PSI and consumes up to 2-1/2 cubic feet of air per minute.

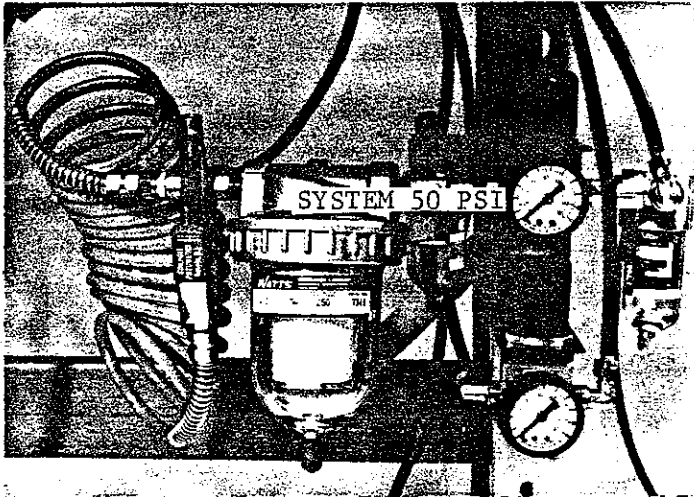

2. The System Pressure Regulator controls the air supply to the unit while the gauge indicates the operating pressure. Regulator and gauge are mounted on the right hand table leg and should be set at 45-55 PSI.

B. PNEUMATIC OILING SYSTEM

An oil lubricator is provided to keep the air system oiled properly. The use of no lubrication will cause unwarranted wear of the components while excessive lubrication causes sluggish operation and an undesirable collection of oil around the components. The lubricator is mounted off the system pressure regulator and gauge on the right hand table leg.

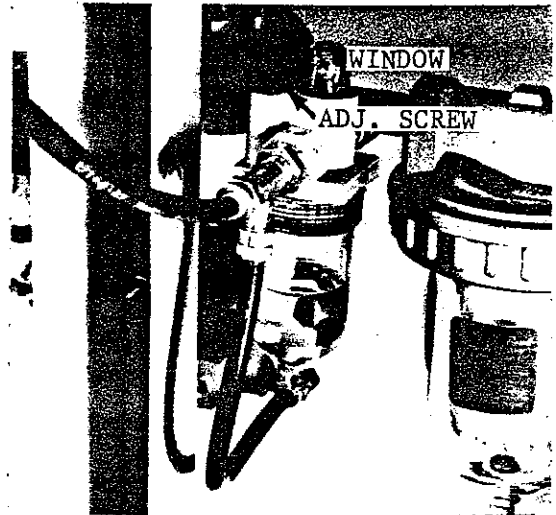

Fill lubricator with Union special Oil Specification No. 174 or an equivalent straight mineral oil.

To adjust:

1. Remove air tubing from presser foot lift air cylinder.
2. Turn air line lubricator adjusting screw clockwise until it gently bottoms on its seat.

CAUTION: Do not overtighten air line lubricator screw as damage to its seat may result.

3. Turn on or connect air pressure and set main regulator to 45 PSI.
4. Slowly turn air line lubricator screw counterclockwise until an oil flow of ONE DROP EVERY 2 MINUTES is observed in the air line lubricator window. This rate corresponds to 1/8 bowl of oil used per 8 hour day. Turning screw clockwise decreases amount of oil while counterclockwise increases amount.

C. AIR FILTERS

There are two air filters used on the unit. The smaller air filter is for the entire system while the larger air filter is used only for the non-lubricated air. The filters, located on the right hand table leg, filter out water vapor and pipe line impurities such as scale and dirt.

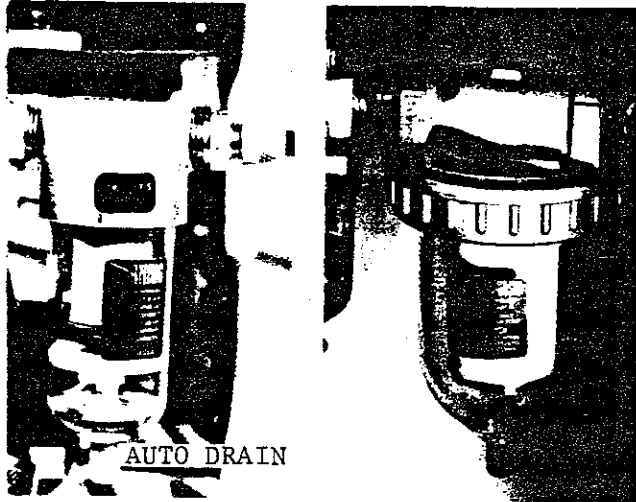

1. The System Air Filter has an automatic drain to dump the water when the bowl fills. The bowl may be removed for cleaning only when the air supply is off. To clean, remove brown filter element and wash with spirits, kerosene, etc., and blow dry with air.

2. The Non-lubricated Air Filter has a white filter element which should be replaced when it changes color.

D. THREAD TRIMMER SYSTEM PRESSURE REGULATOR AND GAUGE

1. The Thread Trimmer System Pressure Regulator and Gauge are mounted on the right hand table leg below the main system filters, regulator and gauge.

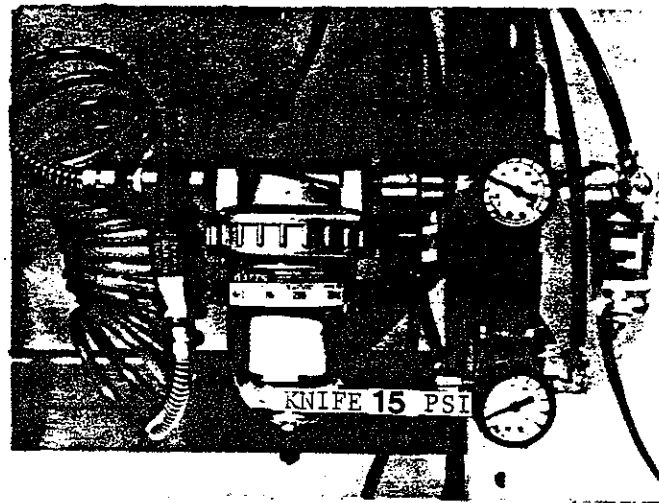

The Klipp-It knife air gauge should be set at **15 PSI**. This air is used to power the knife cylinder.

2. A supply pressure of 80-90 PSI is needed to assist the Klipp-It knife solenoid valve. This pressure is the air supply to the machine before the system regulator and is not adjustable. More than 80 PSI supply presents no problem but LESS than 80 PSI will cause a malfunction in the Klipp-It solenoid.

E. THREAD TRIMMER SPEED CONTROL

The Klipp-It knife is activated by a four-way air solenoid valve mounted under the table board to the right of the sewing machine. The speed of the knife opening is fixed while the return speed can be regulated by an air flow valve.

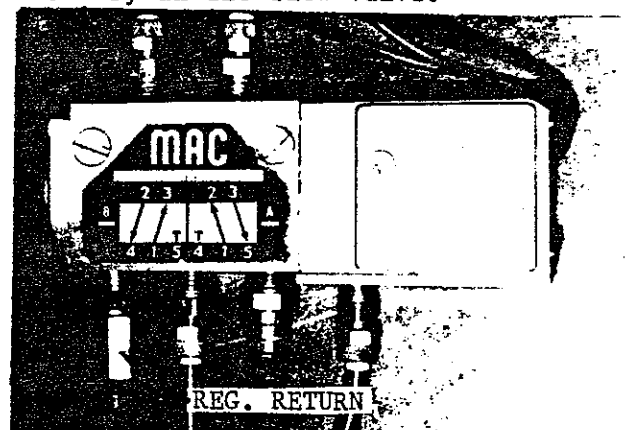

An initial adjustment can be made as follows:

1. Remove throat plate.
2. Turn ON Main and Control power switches.
3. Place CLAMP switch in the THREAD position.
4. Place a jumper wire between terminals 18 & 19. This will put the machine in slow speed. Remove wire and the unit will position & trim.
5. Adjust the flow control so that the return of the knife is noticeably slower than the opening.

NOTE: The knife must return completely BEFORE the tension release closes.

6. Turning flow control adjusting knob clockwise slows the returning speed of the knife. A slower knife returning speed helps reduce bobbin overspin. If speed is too slow, damage to hook deflector plate or knife may occur.

F. THREAD WIPER CONTROLS

The thread wiper blower is an air tube in the clamp which blows the needle thread from under the clamp. This air supply is controlled by a flow control valve and should be adjusted to the lowest possible value that will consistently blow the needle thread from under the clamp.

PNEUMATIC PANEL

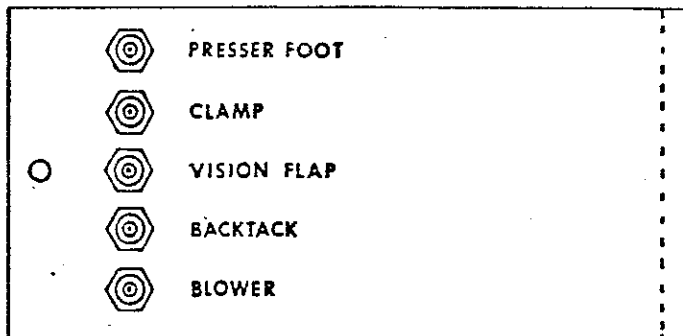

If the needle thread is clamped when the fly is loaded, it will appear on the top of the fly when sewn. Operator loading is the most critical factor affecting needle thread location and thread wiper efficiency.

G. CLAMP LIFT CONTROL

The Clamp Lift control should be set so the clamp lifts without banging but fast enough to avoid pant being pulled while clamp is returning to start position.

H. PRESSER BAR CONTROL

The Presser Bar list cylinder control should be adjusted so the clamp is down on the material before the presser clamp block contacts the clamp. The clamp block must also make contact with the clamp before sewing begins.

I. VISION FLAP CONTROL

The Vision Flap control should be set to delay the opening of the vision flap until the clamp is off the material. This will prolong the life of the vision flap clamp rubber.

J. BACKTACK CONTROL

The Backtack control should be set so that the backtack cylinder is fully extended by the time the clamp just returns to the start position. The backtack control will prolong the life of the Zero Max transmission.

NOTE: If front backtack is used, the backtack control must be fully open to prevent shifting delays.

SECTION 8

ADJUSTMENT OF SUB-SYSTEMS

A. STITCH LENGTH CONTROL.....	8-1
B. STARTING POSITION CONTROL.....	8-1
C. EDGE GUIDE CONTROL.....	8-1
D. SEWING MACHINE HEIGHT CONTROL.....	8-1
E. CLAMP RUBBER ADJUSTMENT.....	8-2
F. NEEDLE/CLAMP ALIGNMENT.....	8-3
G. CABLE TENSION ADJUSTMENT.....	8-4
H. REMOVING CLAMP MECHANISM.....	8-5
I. CLAMP CABLE ROUTING.....	8-6
J. BACKTACK CYLINDER ADJUSTMENT.....	8-7
K. ELECTRIC CLUTCH AND GEAR BOX ADJUSTMENT.....	8-8
L. ZERO-MAX ADJUSTMENT.....	8-10

ADJUSTMENT OF SUB-SYSTEMS

A. STITCH LENGTH CONTROL

Adjustment of stitch length is made with the control lever on the transmission drive under the left side of the table board. Turn the red knob counterclockwise to unlock the adjustment arm and swing the arm to the left to decrease the stitch length. When stitch length is set, tighten the red knob on the adjustment arm to lock in position. After the stitch length has been changed, it will be necessary to readjust the time delay control for the proper stop position.

NOTE: Do not exceed the stitch range of 10 to 18 SPI.

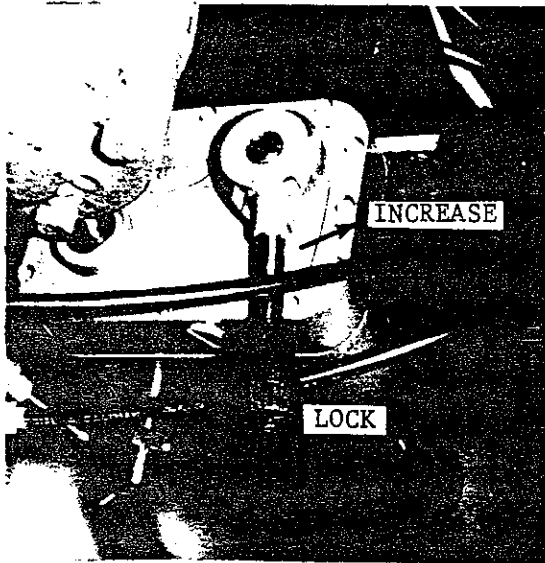

B. STARTING POSITION CONTROL

Turn OFF Control Power Switch for adjustment.

Starting Position, due to variations in pattern and width of fly margin, will vary. Adjust by turning the knob on the left hand side of the unit. Turning the knob counterclockwise moves the starting position closer to the straight line of stitching. Turning the knob clockwise moves the starting position further from the straight line of stitching.

NOTE: Make sure starting stitches are on material.

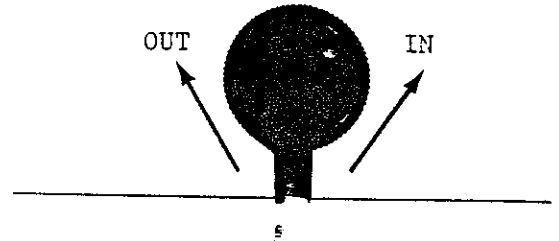

C. EDGE GUIDE CONTROL

The Edge Guide on the clamp is used to assist in locating the work. Adjust by loosening the screw holding the guide and moving it in or out to suit sewing margin requirements.

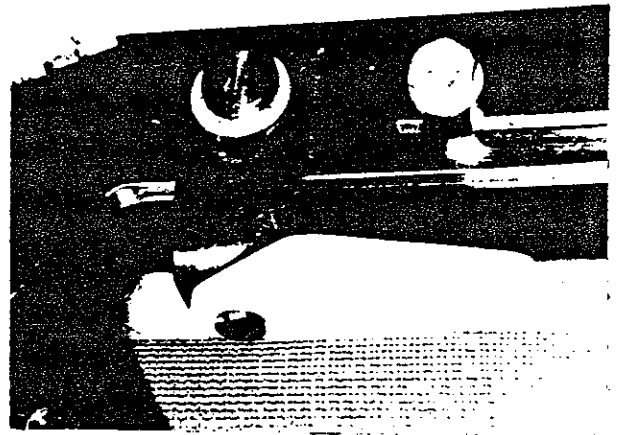

D. SEWING MACHINE HEIGHT CONTROL

The Sewing Machine Height is adjusted by the four corner adjusting screws. Sewing machine should be flush with tabletop. If not, refer to page 2-1.

E. CLAMP RUBBER ADJUSTMENT

The clamp is designed so that the rubber inserts can be easily replaced. They are made in 4 sections. The strips can be ordered as repair parts and should be replaced if the rubber becomes worn or torn.

If clamp replacement or adjustment is necessary:

1. Turn OFF Main and Control power switches. The outer curved and straight clamp rubbers are held in fixed position by screws on the underside of the clamp.

2. Remove the stainless steel tabletop to expose the five clamp screw access holes.

3. Move clamp as far forward (toward operator) as possible and remove air supply to system. The straight outer clamp rubber mounting screws are now accessible through the three holes in the tableboard.

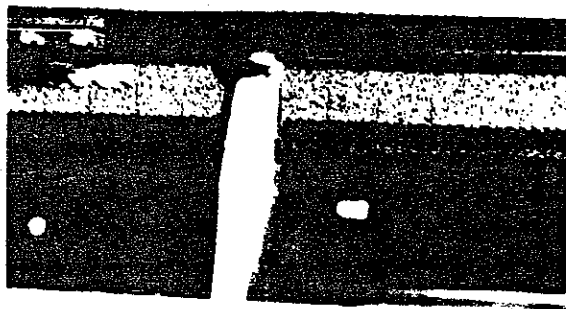

4. After installing the outer straight clamp rubber, connect air supply to unit to raise clamp.

5. Move clamp until it is almost at the left end of its travel and the two access holes line up with the outer curve clamp rubber mounting screws.

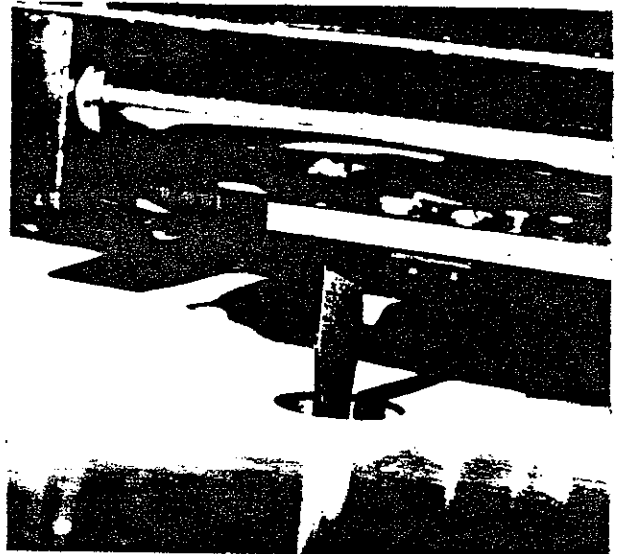

6. Assemble the outer curve clamp rubber so that its inner edge lines up with the edge of the straight clamp rubber.

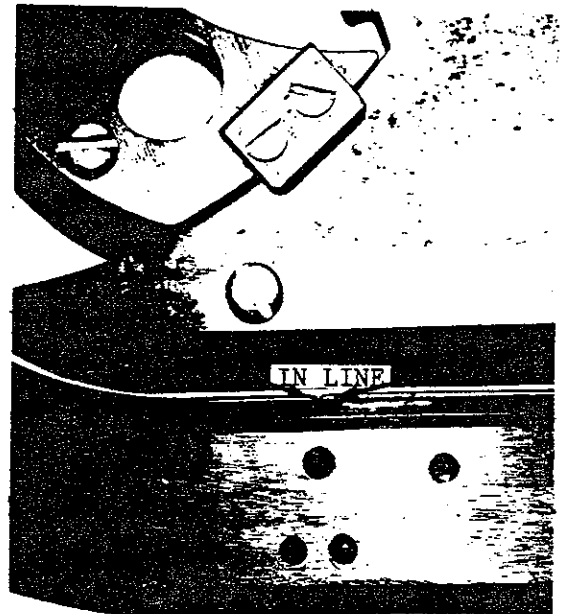

7. Assemble the inner straight clamp rubber to clamp by the three screws accessible from the top of the clamp. Adjust the slot between inner and outer rubber strips to 1/8 inch (3.17mm) opening. This can be done by using the shank end of a 1/8" drill as a gauge. This gap must be maintained to minimize flagging of material resulting in skipped stitches. If slot is less than 1/8 inch, the compressed rubber may be sewn into the garment.

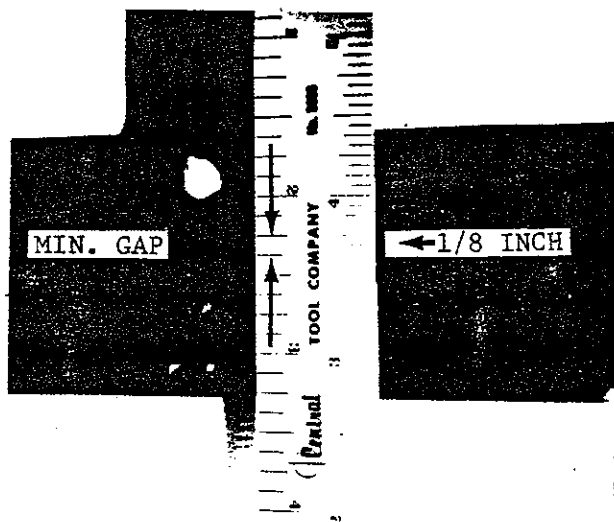

8. Assemble vision flap rubber with the two screws accessible from the top of the flap. The vision flap rubber should be adjusted as close to the needle as possible without touching. This setting insures the sewing of the first few stitches.

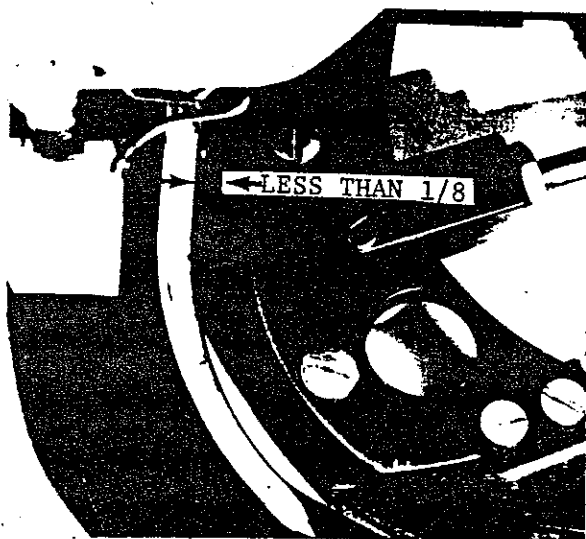

When adjusting the inner section of the rubber inserts, a small amount of clearance between the two must be maintained so that the vision flap will work freely. Be sure to keep the gap between these inserts to a minimum.

NOTE: It may also be necessary to adjust the stroke of the vision flap cylinder to obtain the above.

9. The condition of the edge forming the needle slot of the replaceable strips is very important. Any nicks or rough edges could cause sewing problems and/or the unthreading of the needle during the return stroke.

F. NEEDLE/CLAMP ALIGNMENT

Adjusting relative position of clamp needle slot to the needle is an important setting. Any misalignment can cause machine damage. The adjustment should be made with the MAIN SWITCH TURND OFF and the AIR SUPPLY DISCONNECTED.

1. Remove the two sheet metal covers covering the clamp mechanism.

2. Raise the clamp slightly and move it through its full travel, noting the relationship between the needle hole in the throat plate and the needle slot in the clamp. The needle hole should remain in the center of the clamp needle slot throughout the length of travel.

8-3

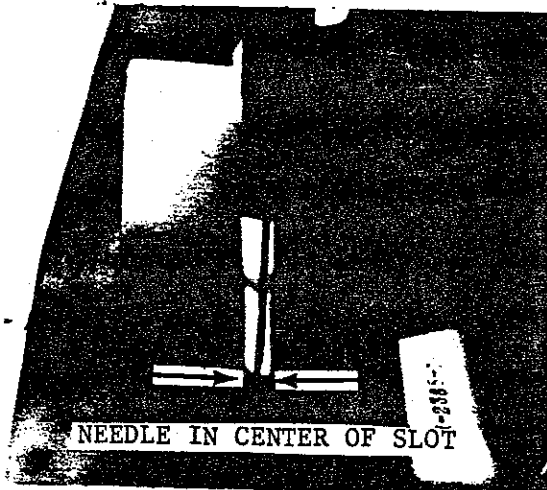

3. If adjustment is required, loosen the idler pulley to obtain slack in the cable.

4. Move the clamp to the left as far as it will go. Loosen the four allen head bolts (two in each end) holding the top cam plate in position. Loosen the front left and right hex head bolts holding the positioning brackets.

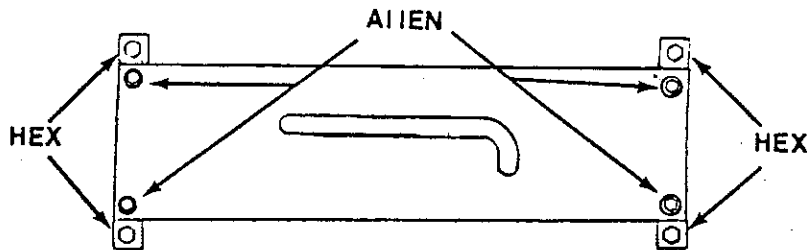

5. Move the LEFT side of the cam plate until the needle is in the center of the clamp slot. Tighten allen bolts.

6. Move the clamp to the right until just before the outer curve rubber.

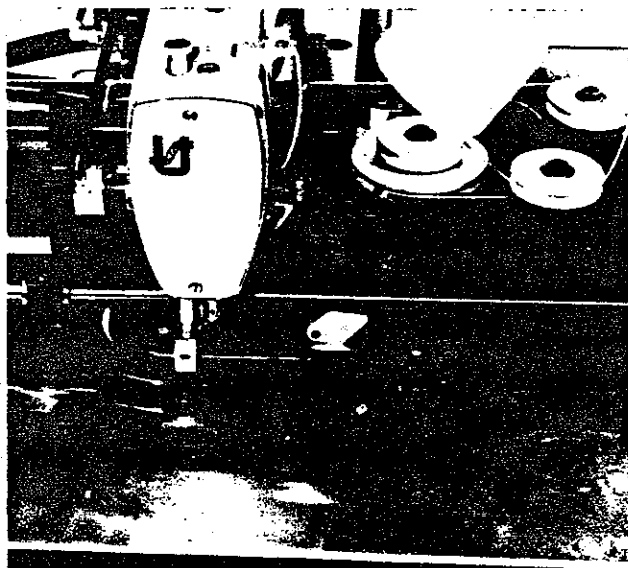

7. Loosen four allen head bolts and move RIGHT side of cam plate until the needle is in the center of the clamp slot. Tighten four allen bolts.

8. Move the clamp to the left as far as it will go and check if needle is still in center of clamp slot. If not, repeat steps 4 to 7.

9. If needle is in the center of the clamp slot, move the positioning brackets up against cam plate and tighten hex head bolts.

10. Move clamp to the starting position and loosen the four allen head bolts.

11. Making sure cam plate is against positioning bracket, move clamp left or right until needle is in center of clamp. Tighten allen head bolts.

12. Remove air tubing to drive motor clutch arm cylinder. Connect air supply and turn ON Main and Control power switches.

13. Adjust cable tension as described in paragraph H.

14. Place a piece of scrap material at least 12 inches long (30.5 cm) and press start switch. Check needle to clamp slot alignment and readjust if necessary.

G. CABLE TENSION ADJUSTMENT

The tension applied to the cable is critical. Too much tension can cause a bind in the return action of the clamp. Too little tension can allow too much slack in the line causing the machine to sew in one place at the start and on the backtack, resulting in needle breakage. To adjust tension:

1. Turn OFF Control Power switch and make sure clamp is in STARTER position.

2. Remove the two sheet metal covers covering the clamp mechanism.

3. Move the clamp all the way left and right several times observing the spring loaded idler pulley. The idler pulley should move at the curved section of the clamp.

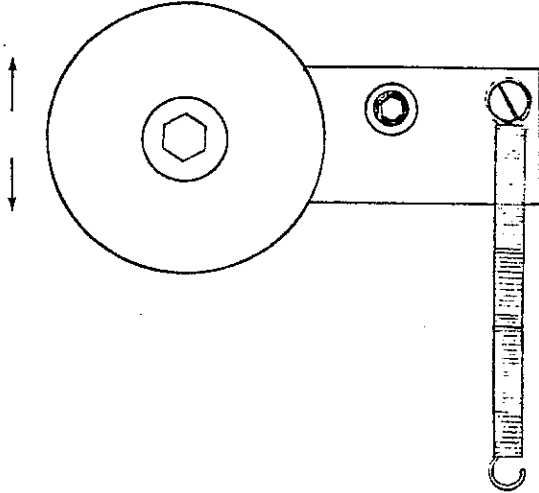

4. If idler pulley does not move, remove cable and manually move pulley, checking for binds. If no binds are present, increase the spring pressure with the adjusting screw and nuts and repeat step 3. There should be only enough spring tension to tension cable but not cause a bind in the clamp return action.

5. If cable touches cam plate, cable tension is too loose.

6. Manually return clamp to start position by moving LEFT DRIVE pulley. If any binds are felt, cable tension is too tight.

H. REMOVING CLAMP MECHANISM

If the clamp mechanism needs to be removed for access to sewing machine or other repairs:

1. Turn Control and Main power switches OFF.

2. Disconnect main air supply.

3. Remove the two top covers covering clamp mechanism.

4. Remove needle from sewing head.

5. Disconnect air lines to clamp lift cylinder, blower tube and vision flap. The disconnect fittings are under the rear of the table board. Hose with blue end goes to outside.



6. Remove cable pivot from cam follower stud.

7. Remove cable.

8. Remove 4 hex head bolts, two from each end.

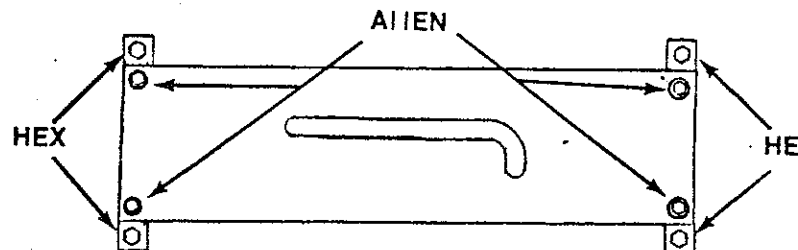

9. Remove 2 pan head screws holding the stainless steel surface in place and slide out sheet. Avoid bending the spring clip on the underside of the stainless steel plate which slides under the throat plate to hold it in place.

CAUTION: The X-Y mechanism will be free to slide back and forth on the rods. Hold the clamp mechanism when removing so it does not slide and pinch fingers.

10. Lift up both ends of the clamp mechanism assembly and slide the complete unit out from the right hand side of the machine. Be careful to hold the clamp section up to avoid damaging rubber inserts. Also avoid hitting limit micro switches when removing mechanism.

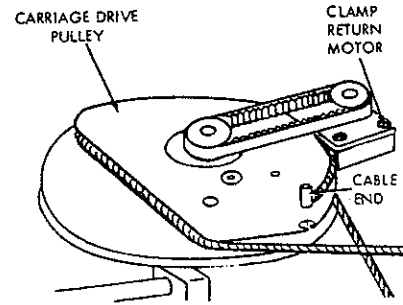

3. If the cables are removed, assemble the cables as shown below.

I. CLAMP CABLE ROUTING

The Clamp Cables (RM-3856 and RM-3857) can be ordered as repair parts. To remove cable:

1. Remove allen set screw from brass bushing and remove cable from bushing.

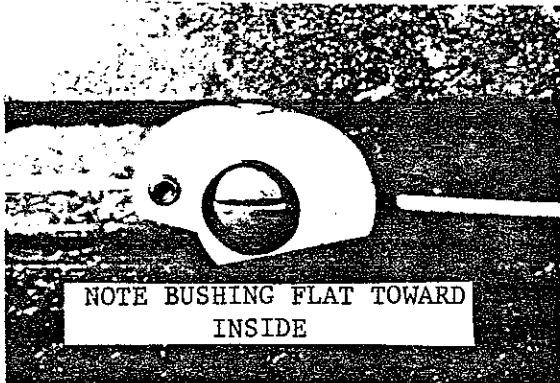

2. Slide the opposite end of the cable out of the LEFT DRIVE pulley by means of a slot.

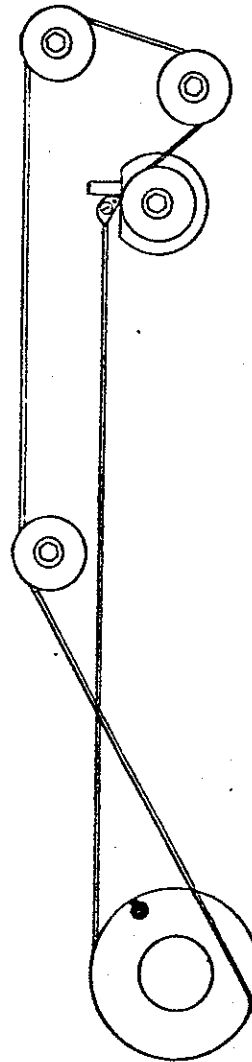

J. BACKTACK CYLINDER ADJUSTMENT

The backtack actuating cylinder on the drive assembly on the lower left end of the table actuates the backtack stitches. The cylinder is attached to a reversing lever on the transmission. The relative position of this lever to the reversing stud is important. If the lever has to be readjusted or slipped:

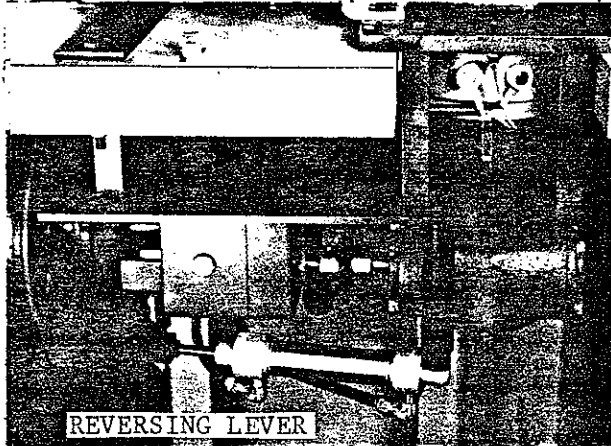

1. Remove the air supply from the unit.

2. Remove the clevis pin holding the reversing arm.

3. Move the driving arm connected to the reversing stud to each extreme end of its travel. Check that the driving arm moves further in both directions than the maximum in and out stroke of the air cylinder.

4. If the above relationship does not exist, loosen the locking screw on the driving arm, rotating it on the reversing stud to get the same amount of travel on the driving arm, at both ends of its movement, relative to stroke of the air cylinder.

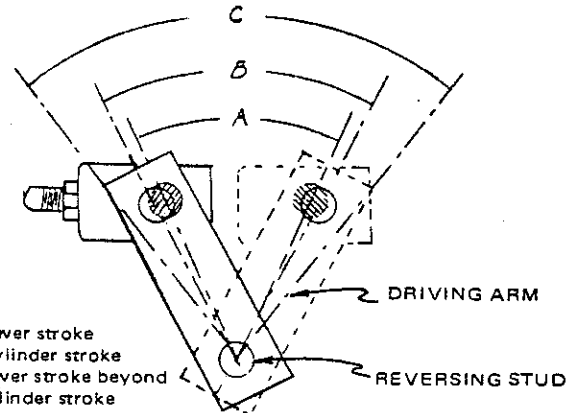

5. The cylinder clevis must move freely on the backtack lever in both forward and reverse positions. If not, the backtack lever should be raised or lowered on its shaft.

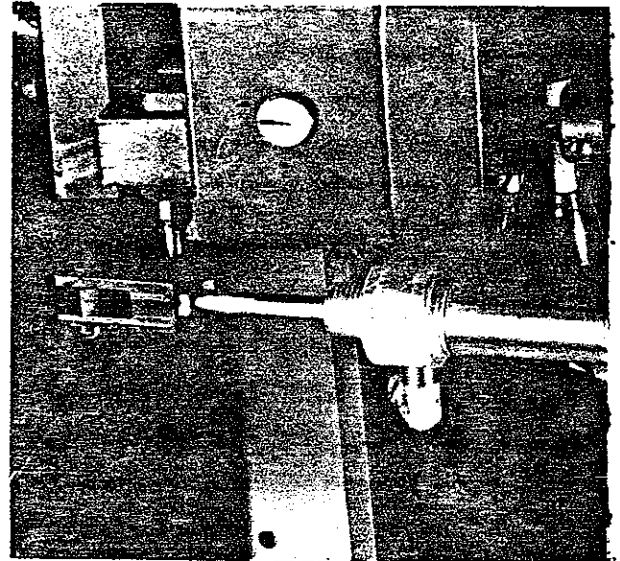

6. After the adjustments have been made, remove the air to the drive motor clutch arm cylinder. Replace cotter pin to backtack cylinder and lever.

7. Connect air supply. Turn ON Main and Control power switches and run unit with a piece of scrap material.

8. Clamp should move smoothly in both forward and reverse direction. If clamp has a jerking motion, the backtack lever is not extended far enough.

9. If further adjustment is necessary, make sure cylinder bottoms out and not backtack lever. If lever bottoms out, excessive pressure will be applied to transmission causing premature failure of transmission.

K. ELECTRIC CLUTCH AND GEAR BOX ADJUSTMENT

Setting of electric clutch and gear box assembly is very important to a smooth clamp return. If for any reason the electric clutch has to be removed and the relative position of the gear box and the upper bearing block has been altered, assemble and align as follows:

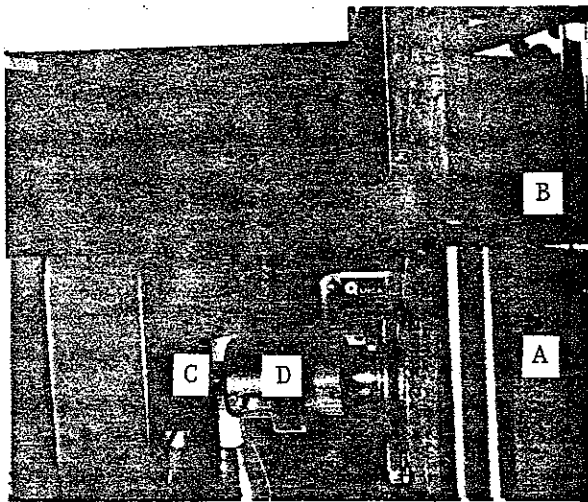

1. Retighten the gear box (A) on the lower bracket (B), being sure the input shaft of the gear box is in line with the output shaft of the transmission (C). The flexible coupling (D) should not bind in any position.

2. Remove the timing belt (E) by loosening the two screws at the base of the motor mounting bracket.

3. Remove the 6 inch diameter double groove pulley (F) from the upper drive shaft being careful not to lose or misplace the thrust bearings. Loosen the screw which prevents the clutch from rotating. This is the same screw that holds the grounding wire to the upper portion of the clutch.

4. Remove the upper portion of the electric clutch by loosening the 2 set screws and lifting the upper drive shaft. Slide out the upper portion from the assembly.

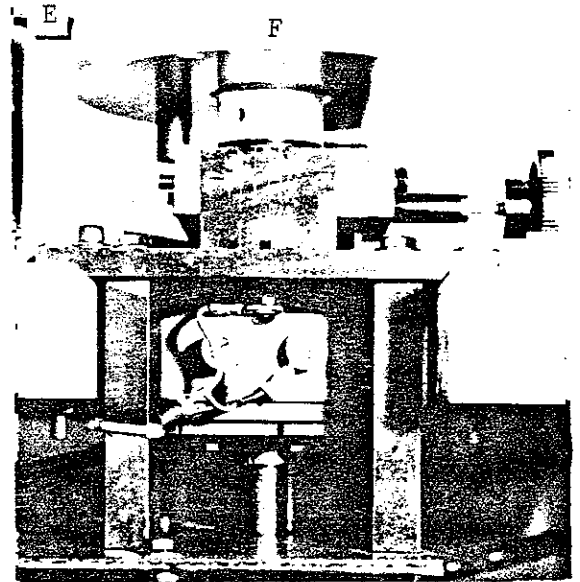

5. Loosen the 2 screws holding the lower splined hub which projects 1/4 inch above the gear box shaft.

6. Lower the upper drive shaft into the upper portion of the spline shaft. The shaft should rotate freely.

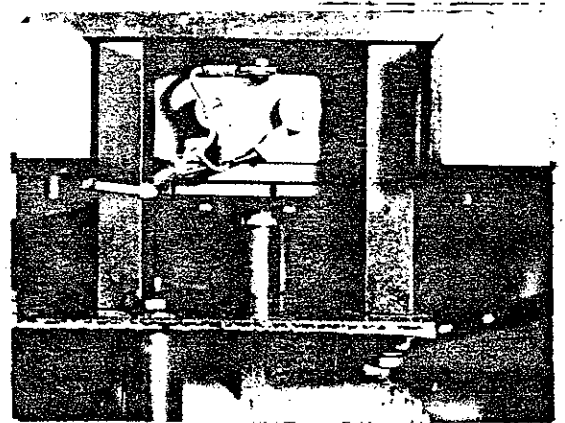

7. If not, loosen the 3 hex head screws which hold the upper plate onto the spacer posts and tap to align the upper plate until the upper drive shaft goes freely into the upper portion of the splined hub.

8. Retighten the 3 bolts being sure that the shaft remains free in the splined hub. If not, repeat steps 5 through 6.

9. Lower the splined hub. Raise the upper drive shaft and reassemble the electric clutch.

10. Tighten the 2 set screws holding the electric clutch onto the upper drive shaft being sure that the screws are seated on the flats.

11. Reassemble the 6 inch double groove drive pulley with thrust bearings in place. Take up the play between the clutch and the pulley to allow only .005 inch clearance.

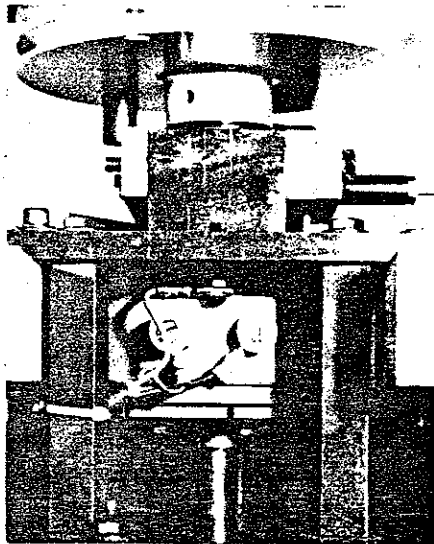

12. Slide the splined hub and the clutch face up allowing .030 to .050 clearance between the face of the clutch and the floating disc. Tighten the 2 hub screws with the key in place. Also tighten the grounding screw to prevent the upper portion of the clutch face rotating.

13. Replace the timing belt and reposition the small motor to leave a small amount of slack in the belt. Lock the motor in place.

14. Reassemble the unit on the tableboard and make all necessary connections with the electric cables, being sure that the green wire is connected to the metal grounding screw.

15. Assemble the cables, V belt, and airline to the backtack actuating cylinder. The unit should be ready to run.

NOTE: Use extreme caution to avoid getting any oil or grease on the clutch face surfaces.

L. ZERO MAX ADJUSTMENT

If a new RM-3522 A Xero Max requires installation, use the following procedure:

1. Install Zero Max and tighten mounting bolts.
2. Place RM-4327 gauge block under the Zero Max output shaft. Measure the gap between the speed reducer input shaft and the gauge block using a feeler gauge.

3. If Feeler Gauge reading is:

- | | |
|-----------------------|---|
| A. (-.015) to (+.005) | No shimming is necessary. |
| B. +.006 to +.015 | Use 1 shim per mounting bolt of speed reducer. |
| C. +.016 to +.025 | Use 2 shims per mounting bolt of speed reducer. |
| D. +.026 to +.035 | Use 3 shims per mounting bolt of speed reducer. |

4. Tighten mounting bolts to speed reducer and recheck height alignment after shimming. If alignment is correct, remove Zero Max. Place coupling over Zero Max and speed reducer. Position Zero Max until coupling rotates freely. Tighten Zero Max mounting bolts and coupling.

5. Assemble self-aligning flange bearing to bearing support. Place shaft through bearing support and assemble 6 inch pulley to shaft. Place shaft over Zero Max input on assembly bearing support to machine. With set screws loose, align bearing and bearing support to Zero Max input shaft so that pulley shaft rotates freely. Tighten all screws and assemble "V" belt.

SECTION 9

ADJUSTMENT OF SEWING HEAD

A.	SETTING NEEDLE BAR HEIGHT	9-1
B.	SETTING THE HOOK	9-1
C.	NEEDLE GUARD INSTRUCTIONS	9-3
D.	THREAD TRIMMER	9-4
E.	THROAT PLATE ADJUSTMENT	9-7
F.	TENSION ASSEMBLY & TENSION RELEASE SOLENOID	9-7
G.	THREAD PULL OFF BRACKET	9-9
H.	THREAD CONTROL	9-9

ADJUSTMENT OF SEWING HEAD

These instructions are special adjustments required on the 63400 LJ used on the 2800 E-3. For other standard adjusting information, refer to catalog 121 M.

A. SETTING NEEDLE BAR HEIGHT

There are two lines engraved on the needle bar. The top line sets the needle bar to the proper height and the lower line is for hook timing.

1. Turn OFF Control and Main power switches and disconnect main air supply.

2. Block open the motor clutch arm so that the handwheel of the machine can turn freely.

3. Turn the handwheel in the operating direction until the needle bar is at its lowest position. The upper timing line should be even with the lower edge of the lower needle bar bushing.

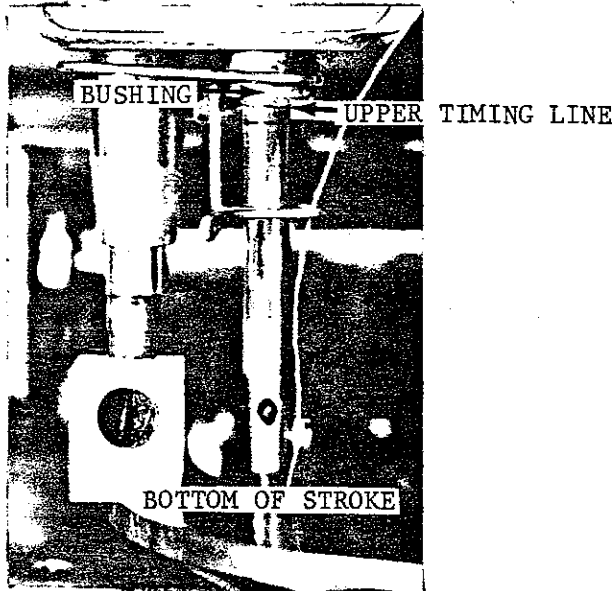

4. Should adjustment be necessary, place needle bar at bottom of stroke, loosen needle bar clamp screw, and reposition the needle bar as required.

5. Before tightening needle bar clamp screw, make sure needle screw just misses eyelet.

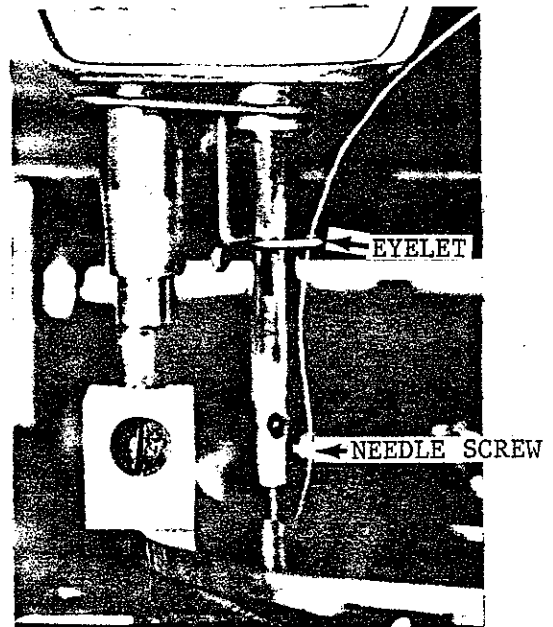

6. Tighten clamp screw securely and recheck.

B. SETTING THE HOOK

1. With the Main Switch OFF, remove belt to machine.

2. Remove the synchronizer plug from Motor Control box.

3. Turn Main Switch ON so sewing machine light is on.

4. Remove two pan head screws holding the stainless steel table top in place and slide sheet out.

5. Remove throat plate. The right hand throat plate screw is accessible through hole in vision flap when the vision flap is manually held closed.

6. Remove Clamp mechanism according to Section 8, paragraph 1.

7. Install new needle.

8. Turn basket 180 degrees and hold into position.

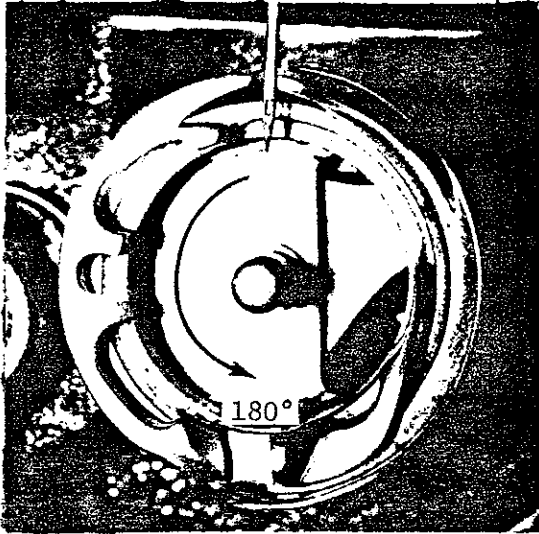

9. Turn the handwheel in the operating direction until the needle bar is in its lowest position. Continue turning the handwheel until the hook timing line is even with the lower needle bar bushing.

10. With the needle bar in the hook timing position, set the HOOK POINT so it JUST TOUCHES WITHOUT DEFLECTING the center of the needle. Snug one of the screws on the hook to hold in this position.

11. Place a .004 shim between the hook hub and the loosened hook shaft collar and tighten the hook shaft collar in place using the 2 set screws.

12. Remove the .004 shim.

13. Loosen the screw which was tightened to hold the hook in place and move the hook back against the hook shaft collar.

14. Set the hook point to the center of the needle and tighten screw opposite the hook point. Tighten remaining screw on hook. Recheck hook timing and clearance.

15. Adjust the positioning finger of the thread trimmer by turning the bobbin case holder until the finger recess is at the top. Place the projection on the finger into the bobbin case holder recess and tighten the positioning finger screws securely, allowing 1/32 inch (.79mm) clearance.



16. Now check for proper needle guarding as described in paragraph C.

C. NEEDLE GUARDING INSTRUCTIONS

A needle guarding surface (A) located on the right side of the needle hole in the bobbin case holder (B) has been provided in this hook.

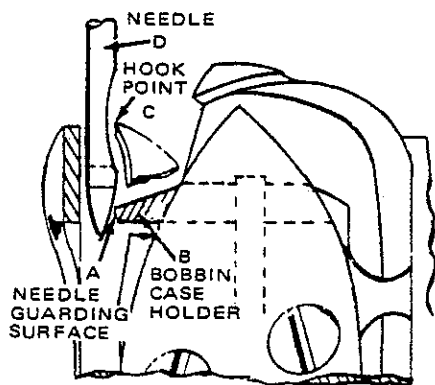

NEEDLE GUARD ADJUSTMENT

The purpose of this guarding surface is to prevent the hook point (C) from coming in contact with the needle (D) at loop-taking time should the needle be deflected toward the hook. With a properly timed hook and correct needle guarding, the needle guard will deflect the needle slightly when the needle is at the bottom of its travel. At LOOP TAKING time, there should be LITTLE or NO DEFLECTION of the needle by the needle guard.

If the above condition does exist, the needle guarding surface will require checking and possible alteration. Before altering the needle guard to suit a new condition, the following should be performed:

1. Check the needle bar for correct height.
2. Insert a new needle.
3. Check to see if the hook timing and hook point to needle spot or scarf clearance are as specified, .004 inch (.10mm) clearance.

NOTE: The bobbin case holder should be released from the positioning finger and held in a position so there is no contact with the needle.

Rotate the bobbin case holder into its normal position and slowly rotate the handwheel until the needle is at the loop-taking position. With proper guarding, there will be no deflection of the needle (away from the hook point) at loop-taking time. There should be no contact between the needle spot and the hook point when light pressure is exerted on the needle toward the hook point. If the guard allows the needle to contact the hook point, the bobbin case holder should be replaced. If needle deflection is excessive, proceed as follows:

1. Remove the BOBBIN CASE HOLDER ONLY by disassembling the gib and pulling on the bobbin case holder stem while rocking the handwheel backward and forward slightly. Now, with the hook still in place, the needle guard position may be checked frequently by reinserting it in the hook and judging the amount of metal still to be removed.

NOTE: A diamond file (TT-60) available through Union Special can be used instead of emery cloth. If used, the hook remains in the machine and the guarding surface may be removed a little at a time.

2. By means of a 1/8 strip of fine emery cloth (#320) with one end secured to the bench, rub the guarding

surface back and forth until sufficient material is removed. Because metal is removed quickly, it is suggested that frequent checks be made to avoid taking off too much material and thereby reducing the effectiveness of the guard.

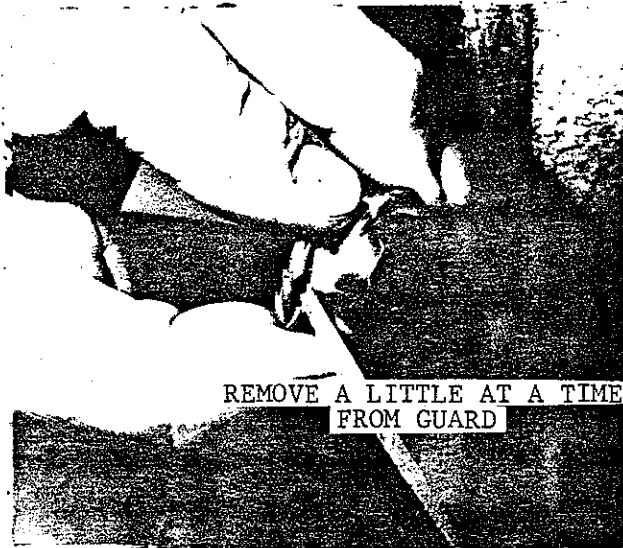

3. When guarding is correct, both the hook and bobbin case holder should be thoroughly cleaned before reassembling the gib.

4. With close settings of the hook point and needle guard, a functional check should be made after any of the above adjustments are made. After threading the needle, turn the hand-wheel until the needle is at the bottom of the stroke. Grasp both ends of the needle thread above the throat plate and see-saw the thread through the eye of the needle.



Only the normal resistance of the needle eye on the thread should be felt. If greater than normal, the needle guard is binding the thread and the needle bar should be raised slightly.

D. THREAD TRIMMER

For Thread Trimmer adjustments, remove the positioning finger and knife assembly from machine and proceed as follows:

1. Remove the Stationary Upper Knife and Movable Lower Knife and check cutting edge for nicks or wear. If there is any doubt, replace the knives.

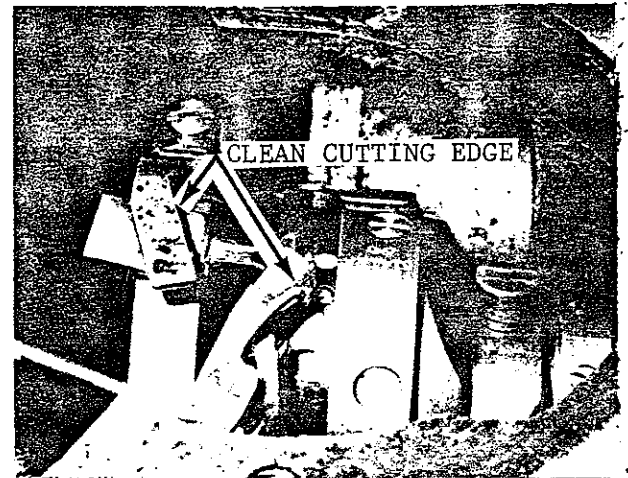

2. Position the Movable Lower Knife on its carrier so that as the knife moves in, the outside edge of the cutting edge coincides with the outside edge of the left positioning finger prong at point (A). To make adjustment, loosen mounting screws.

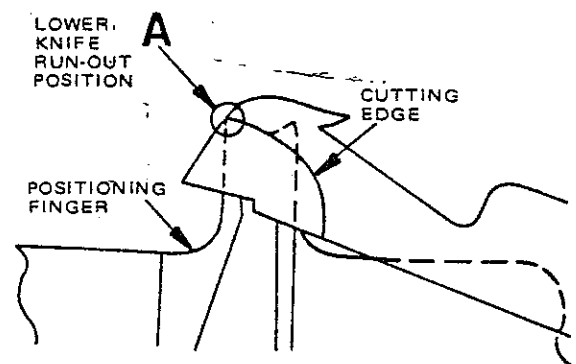

TRIMMER ADJUSTMENT

3. When the knife is all the way in and the pivot carrier stop is against the positioning finger cut out (B), the front edge of the Lower Knife should be FLUSH with the front edge of the Positioning Finger.

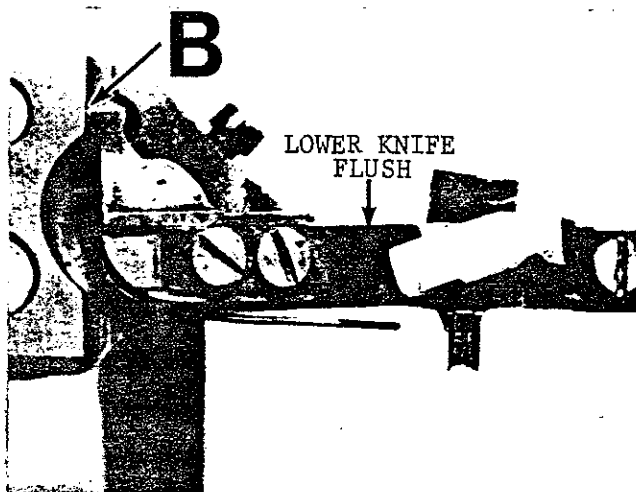

4. Position the Stationary Upper Knife on the Positioning Finger so that the knife base is flush with the front of the positioning finger as shown. Now check and make sure the condition described in 3 is also met.

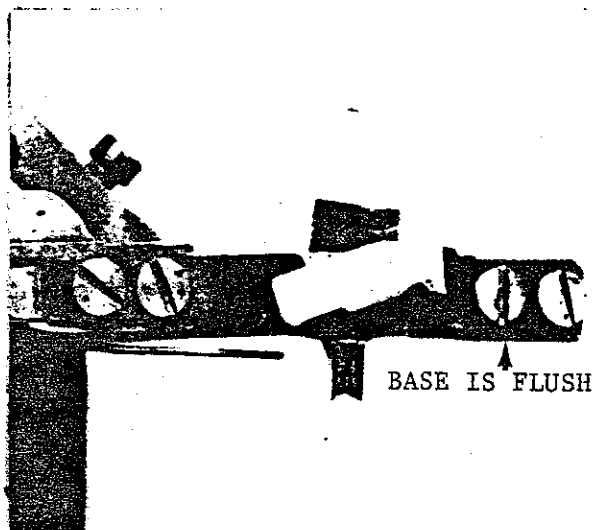

5. The shear angle of the Lower Knife is adjustable by an eccentric bushing. A good starting point would be to have the pin hole in the eccentric bushing located approximately 90° to the hook side of the positioning finger as shown. NOTE: A number 47 drill just fits the pin hole.

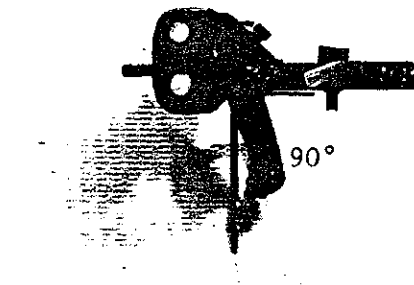

6. Rotate the lower knife inward until the upper knife just contacts the beveled surface of the lower knife. As knife comes in it should deflect upper knife SLIGHTLY (not to exceed .005" [.13mm] when lower knife is to extreme left position). This adjustment is accomplished by loosening eccentric set screw and turning flange screw. NOTE: Be sure bushing is not turned while making this adjustment or parallel adjustment will have to be rechecked.

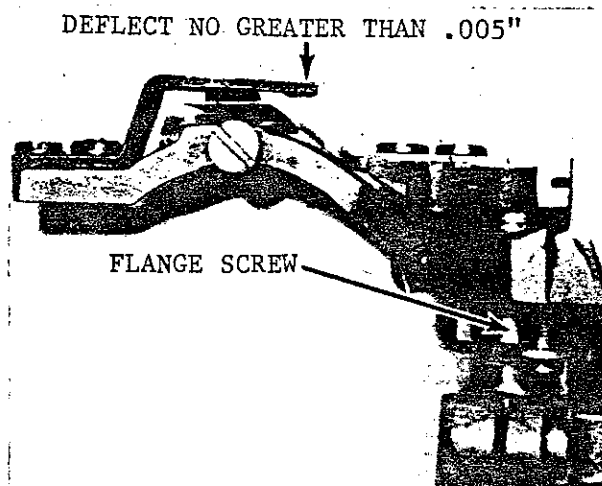

7. Check cutting action with two strands of thread. If threads are not cleanly cut, then move eccentric bushing up slightly or turn until proper cutting is achieved.

8. Attach trimmer assembly to bracket with attaching screws making sure ball stud fits into the driving fork. NOTE: Be sure there is 1/32 inch (.79mm) clearance between the positioning finger projection and bobbin case holder recess.



9. Turn OFF Main and Control power switches and remove air supply to unit. At the rest position, the knife stop located on the lower knife carrier should contact the body of the positioning finger. Also, the cylinder rod should be against its own stop. This adjustment is made by loosening the clamp screw on the pivot release lever and pushing both the lower knife carrier and the cylinder rod against their respective stop. Tighten clamp screw making sure there is no shake or bind in the lower knife carrier.

10. Turn machine handwheel in the operating direction until the hook point is in the 5 o'clock position with the needle on the upstroke. Manually move the cylinder out until the lever touches the stop screw. In this position, the front edge of the lower knife is in line with the front side of the needle slot in the bobbin case holder.

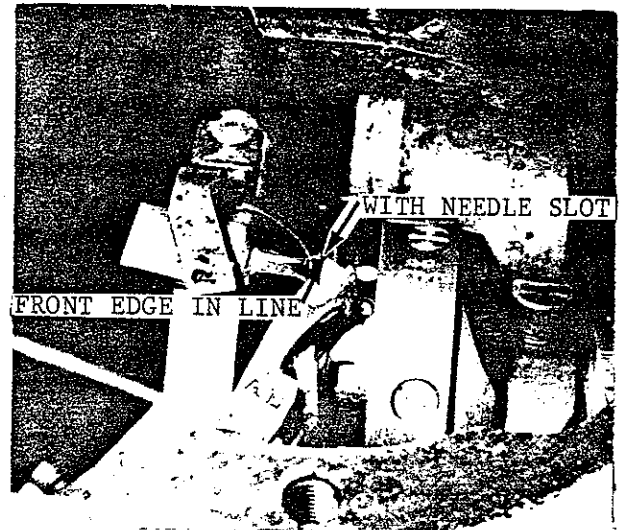

If adjustment is necessary, loosen lock nut and adjust stop screw until condition is met.

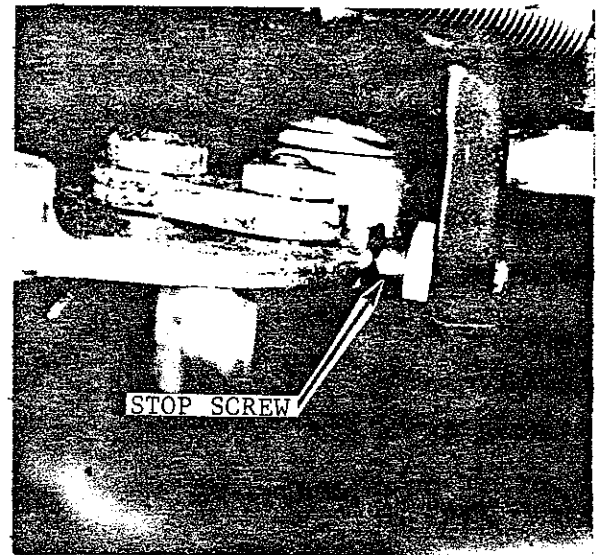

11. Be sure the spring retainer wire enters the bobbin case holder cut-out when the lower knife is in its extreme position.

If not, carefully bend wire. Wire must also NOT make contact when knife is closed.

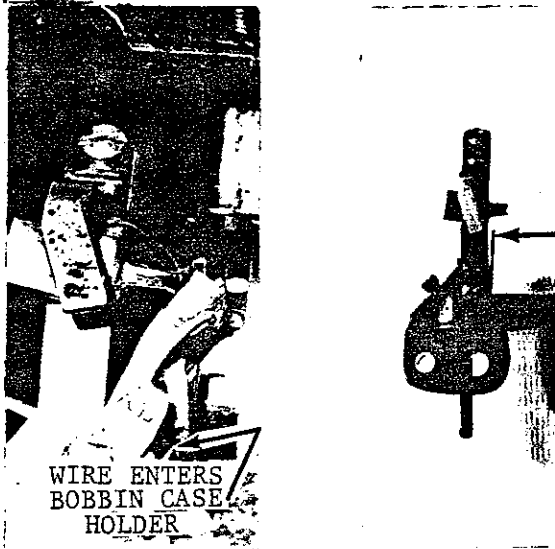

NOTE: Refer to page 7-2 for knife speed control and air pressure settings.

12. The BOBBIN THREAD RETAINER (63411) spring holds both the bobbin thread and needle thread under slight tension so the machine begins sewing with the first needle penetration. The bobbin thread retainer is adjustable up or down in the positioning finger. Adjust so that the threads are adequately pinched and held between the spring and the bottom of the moving Klipp-It knife. Keep the spring edges aligned at right angles to the positioning finger so the underneath angular portion of the moving knife does not strike the edges of the spring. If this occurs, the flat spring surface will not contact the lower surface of the moving knife sufficiently to clamp the threads.

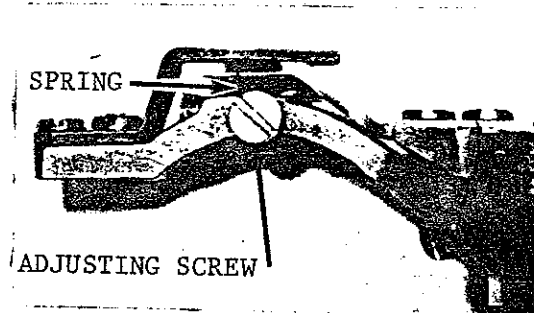

Too much tension on the spring could cause thread breakage at the beginning of the sewing cycle and excessive deflection of the moving knife, affecting the trimming life of the knives.

NOTE: If backtacking is used or the machine stops directly on the material without sewing off, the needle thread tail will be pulled out of the bobbin thread retainer.

E. THROAT PLATE ADJUSTMENT

The throat plate mounting holes are enlarged to allow adjustment. If the throat plate is removed, make sure the needle is CENTERED in the needle hole of the throat plate when replaced.

F. TENSION ASSEMBLY & TENSION RELEASE SOLENOID

1. Test check spring tension. There should be enough tension to assure a good returning snap when spring is depressed and released. Should it require adjusting, loosen set screw in the head located under arm and to the rear of tension assembly and remove tension assembly.

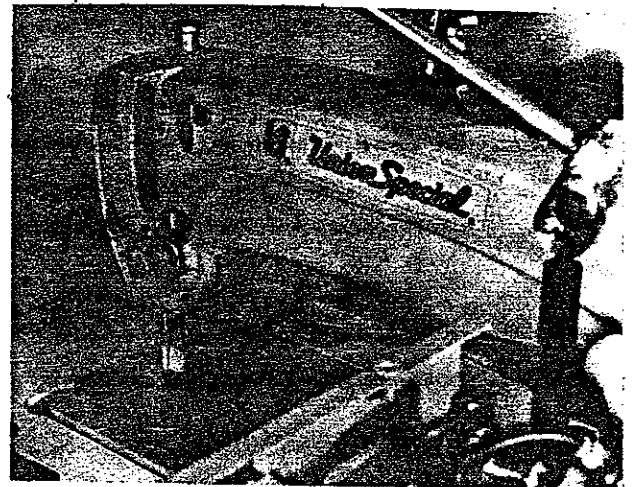

Partially loosen tension post set screw in tension post socket. Turn the tension post counterclockwise until the check spring moves away from the upper stop and has no tension on it. Turn the tension post in a clockwise direction until the spring again touches the upper stop. Then proceed further in the same direction until the desired tension is obtained. When correctly set, the tension post set screw should be drawn up snugly, yet not forcefully. Further adjustment of the check spring tension can be made by inserting a screwdriver into the slotted end of the tension post and turning in the required direction.

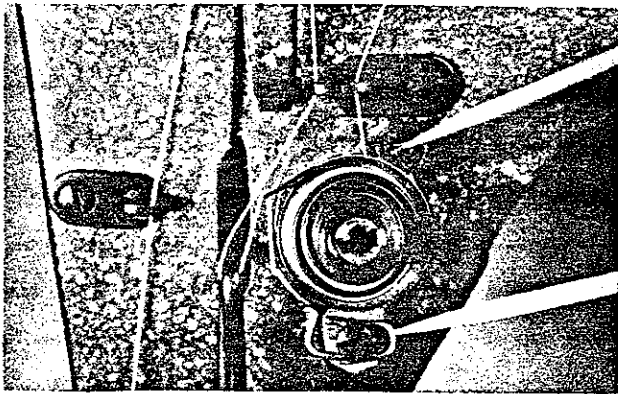

Replace tension assembly and set check spring stop at approximately eleven o'clock (starting point).

2. Set the tension assembly so that the tension discs are centered on the check spring eyelet. Tension release plunger pin must contact tension release pin. The opposite end of the tension release plunger pin must protrude a minimum of 1/32 inch (.79mm) to a maximum of 1/16 inch (1.59mm).

If adjustment is required, move tension post assembly in or out by loosening set screw and moving stop screw as required. Retighten set screw. Tension release plunger pin is to have approximately .005 inch (.13mm) clearance between it and the solenoid plunger pin without thread in the tension discs.



Slip the tension release solenoid and bracket onto bushing and position so that set screw can be secured to flat of bushing. Move in until it just contacts a .005 inch (.13mm) spacer being held against the protruding end of tension release plunger pin. Care should be taken not to exert too much pressure, thereby opening the tension discs. Tighten screw securely and remove spacer.

G. THREAD PULL OFF BRACKET

From the top of the throat plate to the underside of the thread pull off bracket should be set to 4-3/4 inch (120.7mm).

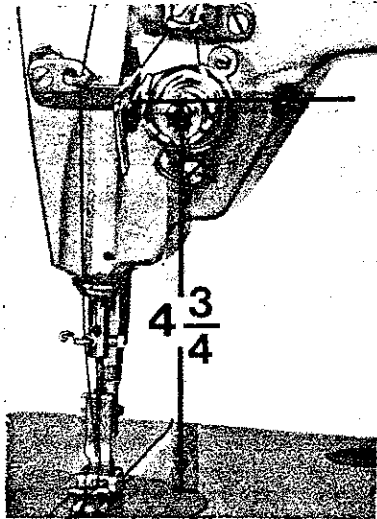

The check spring eyelet is set correctly when the top of the eyelet is 1/16 to 1/8 inch (1.6 to 3.2mm) below a thread running from the tension post to the thread pull up bracket.

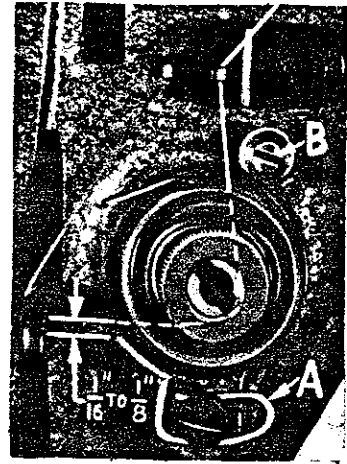

H. THREAD CONTROL

1. The check spring tension is adjusted from 1 to 1-1/4 ounces (28.4 to 35.4 gr.) when measured with a postal scale. This is measured when the check spring is 1/32 to 1/16 inch (.79 to 1.59mm) from its stop.

The eyelet should be close to but not contacting the tension discs so that the check spring will pass freely over it without obstruction.

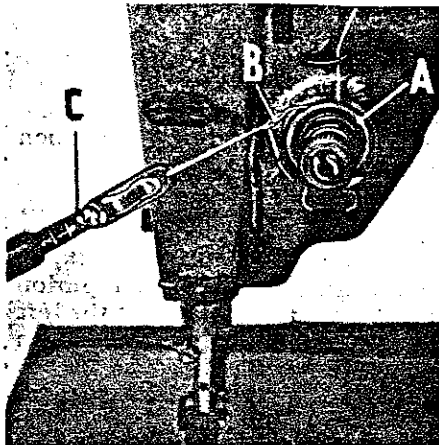

SECTION 10

QUICK STOP DRIVE MOTOR

A. HIGH SPEED ADJUSTMENT.....10-1

B. MEDIUM SPEED ON/OFF SWITCH.....10-1

C. MEDIUM SPEED ADJUSTMENT.....10-2

D. MEDIUM SPEED TIME DELAY.....10-3

E. POSITIONING SPEED ADJUSTMENT.....10-4

F. SYNCHRONIZER ADJUSTMENT.....10-5

G. CLUTCH/BRAKE CLEARANCE.....10-7

H. SERVICING CLUTCH/BRAKE ASSEMBLY.....10-8

QUICK STOP DRIVE MOTOR

A. HIGH SPEED ADJUSTMENT

1. With Control and Main Power switches OFF, disconnect the black wire to the electric clutch to prevent movement of clamp and carriage during testing. Make sure disconnected wire does not touch anything.

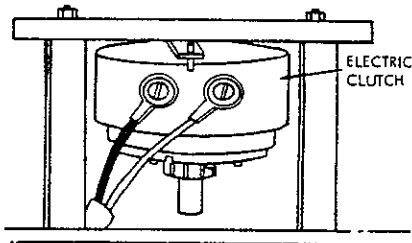

2. Turn ON Main and Control Power switches. Remove needle, bobbin case and thread from machine. Operate the machine in a normal manner using a scrap piece of material. Machine will start at slow speed and then remain at high speed with the clamp not moving.

3. With machine running at high speed, turn P2 CLOCKWISE on Motor Control Panel until motor speed drops. Turn P2 COUNTERCLOCKWISE until motor speed is at MAXIMUM and then continue to turn P2 ONE MORE TURN COUNTERCLOCKWISE.

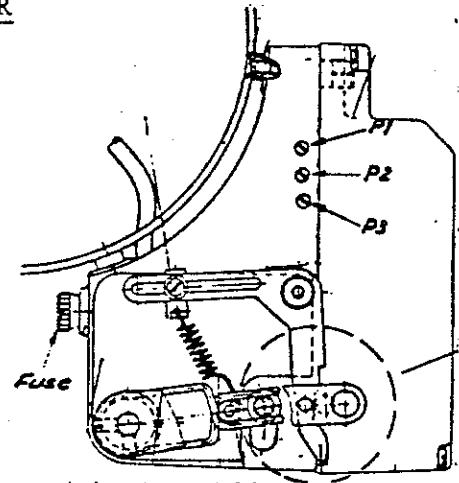
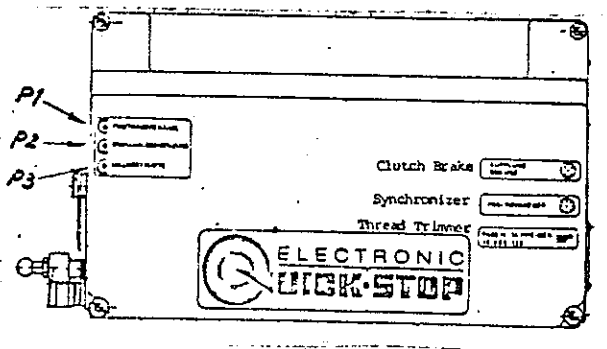

4. Press emergency stop button to stop machine. High speed is now calibrated. If additional speeds are to be checked, refer to the appropriate paragraphs in this section.

5. If no further adjustment is required, turn OFF Control and Main Power switches. Reconnect black wire to the electric clutch. Insert needle, bobbin case, and thread machine.

B. MEDIUM SPEED ON/OFF SWITCH

1. The Medium Speed On/Off Switch is located on the RM-4372 Quick Stop Motor Control Panel. Remove the plastic control panel cover for access to switch.

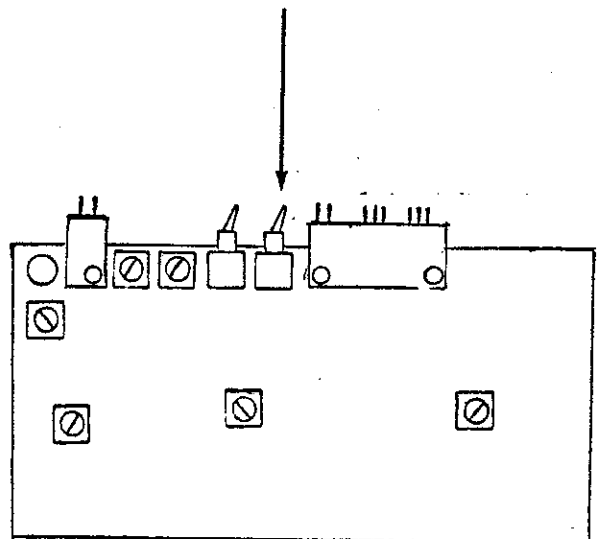

2. When the switch is placed in the OFF position, the unit will:

- a. Start sewing at slow speed for first few stitches.
- b. Sew at high speed until stopping or backtacking sequence occurs.

3. When the switch is placed in the ON position, the unit will:

- a. Start sewing at slow speed for first few stitches.
- b. Sew at high speed until photocell is uncovered and Medium Speed Delay times out.
- c. After Medium Speed Delay times out, unit will sew at the adjusted medium speed until stopping or backtacking sequence occurs.

NOTE: Stop Position 1 is used for sewing with medium speed OFF and Stop Position 2 for medium speed ON.

C. MEDIUM SPEED ADJUSTMENT

1. When the Medium Speed ON/OFF switch is placed in the ON position, the unit will slow down to an adjustable medium speed as it approaches the waistband area.

2. Medium speed is used to prevent thread breakage, damage to the hook point, and needle heat when crossing thick waistbands. While a slower medium speed is better for sewing and hook performance, it does increase machine cycle time. Normally a speed range of 1500 to 2500 RPM is used for medium speed.

3. Medium speed is adjusted by removing the grey plastic cover for the motor control panel and turning the Medium Speed Adjust potentiometer on the RM-4372 motor control panel. Turning potentiometer CLOCKWISE INCREASES MEDIUM SPEED. Although this adjustment has no effect on the other sewing speeds, it does affect the stopping position as well as the location where medium speed begins. Therefore, if the medium speed is changed, the adjustments for Stop Position 2 and Medium Speed Delay are required for stopping at the proper position on the garment.

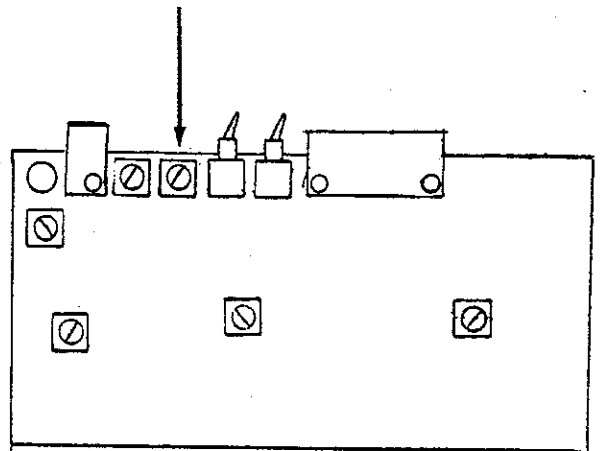

4. To check and adjust medium speed with a tachometer:

- a. Turn Control and Main power switches OFF. Disconnect the black wire to the electric clutch to prevent movement of clamp and carriage during testing. Make sure disconnected wire does not touch anything.

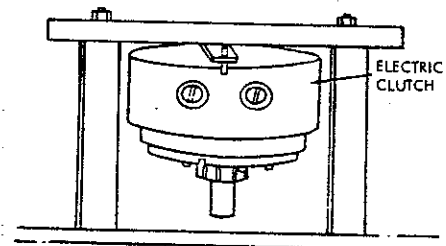

b. With grey plastic cover removed from Quick Stop Motor Control Panel, place MEDIUM SPEED TEST switch in the TEST position. Make sure Medium Speed ON/OFF switch is in the ON position.

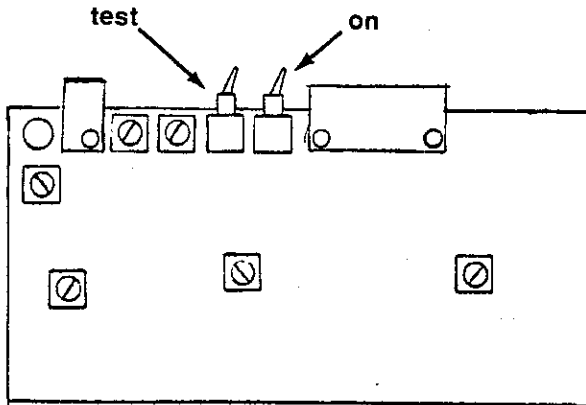

c. Turn ON Main and Control power switches. Remove needle, bobbin case, and thread from the machine.

d. Operate the machine in a normal manner using a scrap piece of material. Machine will start at slow speed and then remain at high speed without movement of the clamp.

e. While sewing at high speed, manually move the clamp to the left until the photocell is exposed. When the photocell is exposed, the machine will run at medium speed.

f. With machine running at medium speed, adjust medium speed potentiometer until desired medium speed is obtained.

g. To stop machine after adjustment is made, push the Emergency Stop button.

h. Turn OFF Control and Main Power switches. Place Medium Speed Test Switch into the RUN position and assemble grey plastic cover to motor control panel.

i. Reconnect black wire to the electric clutch. Insert needle and bobbin case and thread machine.

j. After medium speed has been changed, adjustments of Stop Position 2 and Medium Speed Delay are required for stopping at the proper position on the garment.

D. MEDIUM SPEED TIME DELAY

1. The Medium Speed Time Delay controls the amount of time after the photocell is uncovered before the machine goes into medium speed. The Medium Speed ON/OFF switch must be turned ON for the delay to occur.

2. The Medium Speed Time Delay should be set so that the machine switches from high speed to medium speed a few stitches before the start of the waistband.

3. The Medium Speed Time Delay is adjusted by removing the grey plastic cover for the motor control panel and turning the Medium Speed Time Delay potentiometer on the RM-4372 motor control panel.

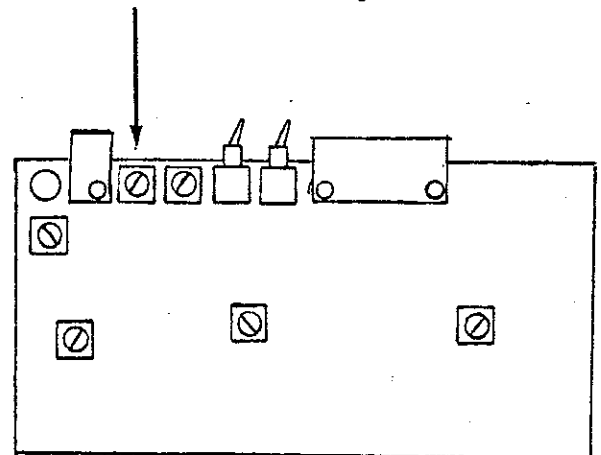

4. Turning the Medium Speed Time Delay COUNTERCLOCKWISE DECREASES the amount of time before switching from high speed to medium speed. In other words, COUNTERCLOCKWISE causes the machine to switch from high speed to medium speed SOONER or further from the waistband edge.

5. Adjustment of the Medium Speed Time Delay affects the stopping position on the garment. Therefore, after adjustment of the delay potentiometer, adjustment of Stop Position 2 is required.

6. When adjustments are completed, assemble grey plastic cover to the motor control panel.

b. Unplug the two BLACK plastic quick disconnect connectors going to the Quick Stop motor control panel to cause machine to sew only at slow speed.

E. POSITIONING SPEED ADJUSTMENT

1. The positioning speed is used for the starting stitches, slow sew backtacking and trimming. Positioning speed must be set at 195 RPM. A faster speed will cause trimming problems and possible hook and trim knife damage.

2. To adjust positioning speed:

a. Turn OFF Control and Main power switches. Disconnect the black wire to the electric clutch to prevent movement of clamp and carriage during testing. Make sure disconnected wire does not touch anything.

c. Turn ON Main and Control power switches. Remove needle, bobbin case, and thread from the machine.

d. Operate the machine in a normal manner using a scrap piece of material. Machine will sew only in positioning speed.

e. Using a tachometer to measure speed, positioning speed should read 195 RPM.

f. If positioning speed requires adjustment, turn P1 on motor control panel. An access hole on the side of the panel cover allows adjustment without the need of cover removal.

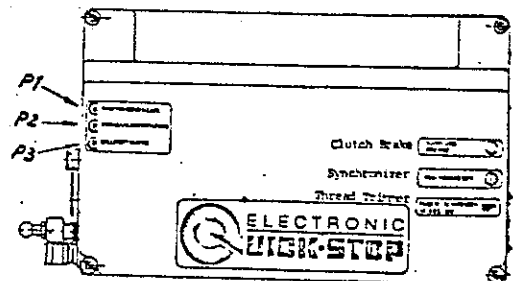
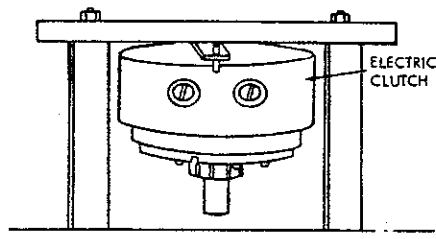

g. P1 is a multi-turn potentiometer. Turning P1 CLOCKWISE INCREASES positioning speed.

h. When positioning speed is set, push the Emergency Stop Button to stop machine. Turn OFF Control and Main Power switches.

i. Reconnect black wire to the electric clutch. Reconnect the black plastic quick disconnects.

j. Insert needle and bobbin case and thread machine.

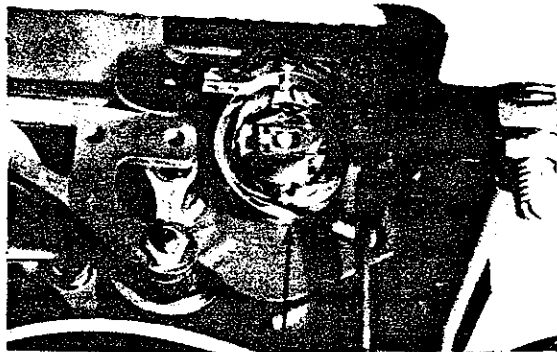

c. Remove the protective cap on the end of the synchronizer.

F. SYNCHRONIZER ADJUSTMENT

1. The synchronizer on the sewing machine handwheel determines when the Klipp-It trim knife activates and also the up position of the needle for starting. Inside the synchronizer there is an additional sensor and sensing disc used to tell the motor control panel the sewing speed.

2. The synchronizer contains three discs with either a notch or a tab to break the sensor's light beam. Each disc is independently adjusted and controls separate trimming functions. To adjust synchronizer:

a. Turn OFF Control and Main power switches. Remove air supply to unit.

b. Rotate the sewing machine handwheel in operating direction until the HOOK POINT is in the 6 O'Clock position and the NEEDLE is on the UP STROKE.

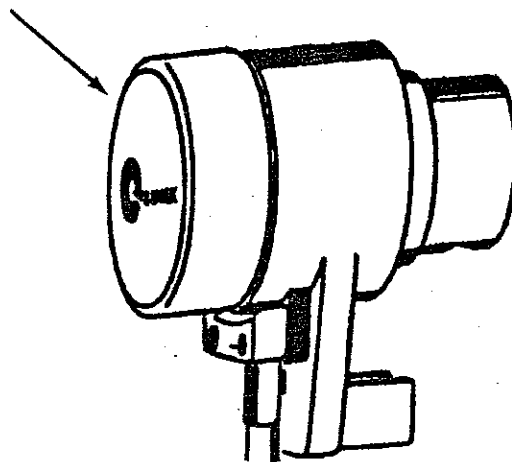

d. Loosen set screw by approximately 1/2 turn or just enough to be able to move the discs.

e. Rotate the OUTSIDE DISC ONLY (disc furthest from handwheel) until the LEADING edge of the tab is in center of the sensor.

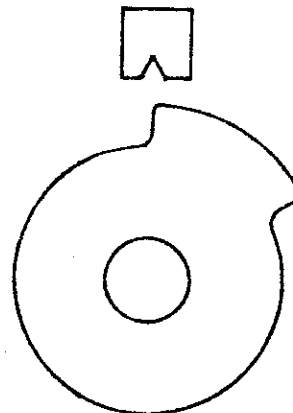

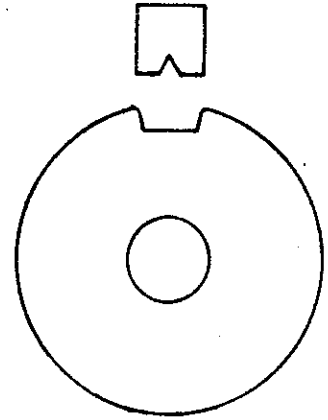

f. The position the trim knife fires is now set. Whenever a disc is adjusted, the settings of the other two discs should be checked in case they were moved during the adjustment.

g. Rotate the handwheel in operating direction until the needle thread take up is 1/8 inch (3 mm) from the top of its stroke.

h. Rotate the MIDDLE DISC ONLY until the CENTER of the tab is in the center of the sensor. The position of the needle up is now set.

j. Rotate the INSIDE DISC ONLY (disc closest to handwheel) until the CENTER of the notch is in the center of the sensor. The needle down position is now set.

k. Tighten the set screw and recheck settings of all three discs.

l. Replace protective cover and rotate handwheel to needle up position. Connect air supply and unit is ready for operation.

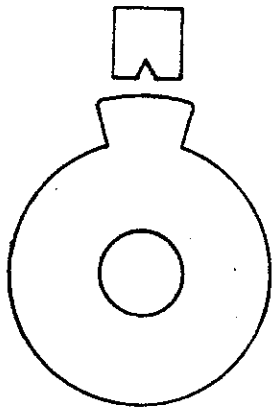

i. Rotate the handwheel in operating direction until the needle is at the bottom of its stroke.

G. CLUTCH/BRAKE CLEARANCE

1. Remove fan cover (1.2) by turning counterclockwise. Set cover aside.

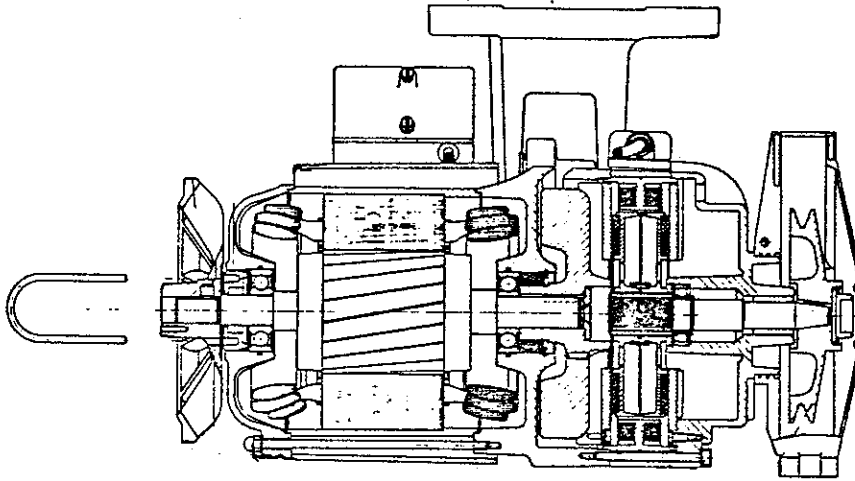

2. Insert adjusting tool (8) into the bores (x) on fan (1.4). Exert pressure on adjusting tool (8) and turn fan (1.4) until the tool locks into the bores of adjusting screw (1.6).
3. With tool locked in place (8) turn fan (1.4) clockwise until pulley (3.6) has a moderate drag when rotated with the other hand.
4. Rotate adjusting tool (8) and fan (1.4) 120 counterclockwise (120 = distance between cap nuts [1.8] on the end bell. Required clearance = 0.5 mm).

NOTE: To prolong cork facing life and increase smoothness of operation, the following lubrication should be performed annually:

1. Disassemble clutch/brake assembly as described on the reverse side.

2. Remove clutch and brake discs.

3. Clean cork surfaces of the discs and the metal facings of the flywheel and brake surfaces with a clean, lint free cloth. NOTE: Mineral spirits solvent or carbon tetrachloride can be used on metal surfaces only to speed up cleaning.

4. Apply 3 segments of Quick grease (part No. 051.011) about one inch long as shown in the illustration to the cork surfaces.

5. Spread grease evenly on both cork surfaces.

6. Install on splined shaft after lightly coating the splines with the special grease.

7. Reassemble to motor and check for clearance (see above).

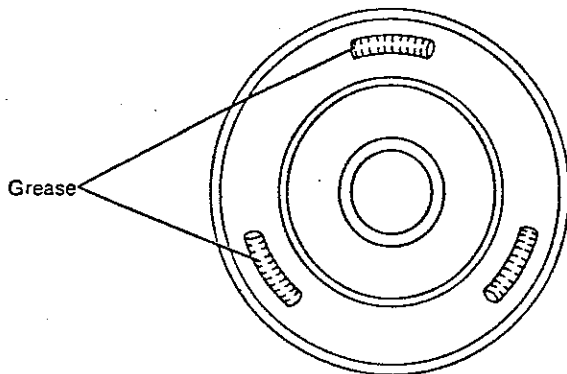

H. SERVICING CLUTCH/BRAKE ASSEMBLY

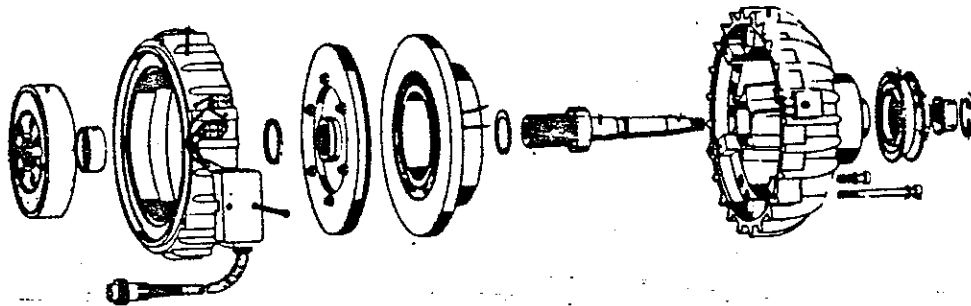

1. Remove V-Belt and belt guard (1).
2. Disconnect cables which attach clutch housing to control box.
3. Remove the three screws located approximately 120 degrees apart (2). When removing last screw, place hand under clutch/brake housing so that unit will not fall.
4. Keep clutch/brake housing tilted slightly downward (pulley side down) to keep the clutch/brake disc in place.
5. Place the clutch/brake housing, pulley side facing upwards, on a clean flat surface. Separate the clutch solenoid from the end bell. Note: Use caution during disassembly and reassembly to ensure alignment and insertion of the (2) solenoid electrical connection pins into the mating socket of the end bell. Slide the clutch and brake discs off the splined shaft of the end bell. Put the end bell aside and inspect the clutch/brake discs for wear. If cork surfaces are smooth and if cork on clutch disc projects beyond the outer metal rim discs are okay.
6. Clean the surfaces of the face plates with an oiled rag. These surfaces should be smooth. If you find nicks and gouges on them, replace the plates.
7. Thoroughly clean the cork faces of the clutch/brake discs using a clean, dry rag. Apply grease (Quick No. 051.011) in 3 - one inch segments every 120 degrees. Spread the grease evenly over the entire cork surfaces.
8. Apply a small amount of grease to the brass splines on which the clutch/brake discs move. This will assure proper action.

9. Reassemble the clutch/brake discs making sure the rubber "O" rings (part #408.009) and the stop washer (#250.008) are in good condition. To assure proper operation of the cooling system, make certain that the vent holes are lined up.
10. Reinstall the clutch/brake discs and housing by reversing the procedures outlined in sections 3.,2., and 1.
11. Once reinstallation is completed, check the clutch/brake clearance as outlined on the reverse side.

SECTION 11

GENERAL MAINTENANCE

A. CLEANING 11-1

B. LUBRICATION 11-1

C. REPLACEMENT 11-2

D. UNIT CLEANING, LUBRICATION, & REPLACEMENT 11-3

SECTION 11

GENERAL MAINTENANCE

A. CLEANING

1. TWICE DAILY remove lint from hook area. Accumulated lint will cause skipped stitches, thread breakage, and/or failure of the Klipp-It to cut properly. An air nozzle is provided on the unit to clean the lint.

a. Remove bobbin case and bobbin. Use air nozzle to blow inside the hook and upward to remove lint in needle guarding area.

b. Blow across top of hook and bottom of throat plate to remove lint that has collected on the bottom of the throat plate.

c. Blow off the Klipp-It knife area.

2. Remove 2 top covers at least ONCE A MONTH and remove lint. Wipe X-Y rods with a clean oily rag.

3. Remove and clean the brown filter element periodically by washing with spirits, kerosene, etc., and blowing dry with air. The white filter element from the larger filter unit should be replaced when it changes color.

4. With the air nozzle supplied, blow out the Quick motor with end fan cover removed ONCE A MONTH.

B. LUBRICATION

1. Check the sewing head oil level daily by examining oil sight gauge and adding Union Special Spec. 86 oil as required. See Catalog No. 121M for proper care and lubrication.

2. Check the unit lubricator once a week. A setting of one drop of oil every 2 minutes of unit operation is sufficient for proper lubrication of the pneumatic system.

a. Periodically clean adjusting screw needle valve and seat and the small felt filter by swishing in a cleaning fluid and blowing off with air.

b. Drain off any contaminants or water in the bottom of the bowl.

3. The gear reducer contains the proper amount of Texaco Pinnacle Cylinder Oil (a Texaco product) from the factory. This oil should be replaced after the first 30 days (8 hours daily) of unit operation. After this initial oil change, the oil should be changed about every 6 months (8 to 10 hours duty).

Some reducers have grease fittings at the upper bearings. They should be lubricated with Texaco Multifax EP grease or equal after each 200 hours of operation.

NEVER OVERFILL THE GEAR REDUCER WITH OIL. It will cause oil leakage and overheating, resulting in rapid wear of oil seals, bearings, and gears. The oil should be filled to the oil level plug or gauge and never any higher.

4. The transmission drive runs in oil and is filled with the proper amount and kind at the factory. All drives are permanently lubricated. However, the oil level should be checked periodically to be sure the case is at least 1/2 full. When necessary, fill through hole in housing with transmission No. 400 lubricant or SAE 40 detergent motor oil.

5. Idler pulley bearings for clamp drive V belt should be greased every 6 months. Zerk fitting is on the bearing housing.

6. Drive pulley bearings require a thin coat of cut grease every 6 months.

7. The Quick Stop motor clutch and brake discs should be cleaned and greased every 2 years (refer to section 10 for motor maintenance).

C. REPLACEMENT

1. Check needle ONCE EACH DAY for burrs or excessive sharpness and replace as required with 180 SXS 100/040 or 285 GKS 100/040.

2. The check list following this section is to be used when a service or inspection call is made. We recommend that plant mechanics use this check list when the unit is inspected periodically. A good maintenance program will prevent unnecessary downtime.

D. UNIT CLEANING, LUBRICATION, AND REPLACEMENT PROGRAM

PART	WEEKLY	MONTHLY	6 MONTHS	1 YEAR
<u>CHECK CONDITION AND/OR CLEAN</u>				
Clamp Rubber	X			
Rotary Hook	X			
Throat Plate	X			
Air Tubes to Clamp	X			
Trimming Knives		X		
Bobbin Thread Spring		X		
Wire Cables		X		
Vee Belts			X	
Quick Stop Motor		X		
<u>CLEAN AND LUBRICATE</u>				
Sewing Head	X			
Air Filter & Regulator	X			
Cam Plate		X		
Cam Roller		X		
X-Y Rods		X		
Gear Reducer			X	
Transmission			X	
Idler Pulley Bearings			X	
Drive Pulley Bearings			X	
Quick Stop Motor Clutch/Brake				X
<u>REPLACEMENT</u>				
Needle	X			