

Eastman®

THE EASTMAN®
Light Table

Model: 68-26441-MS

Service Manual

Technical Support:
1-800-872-5595

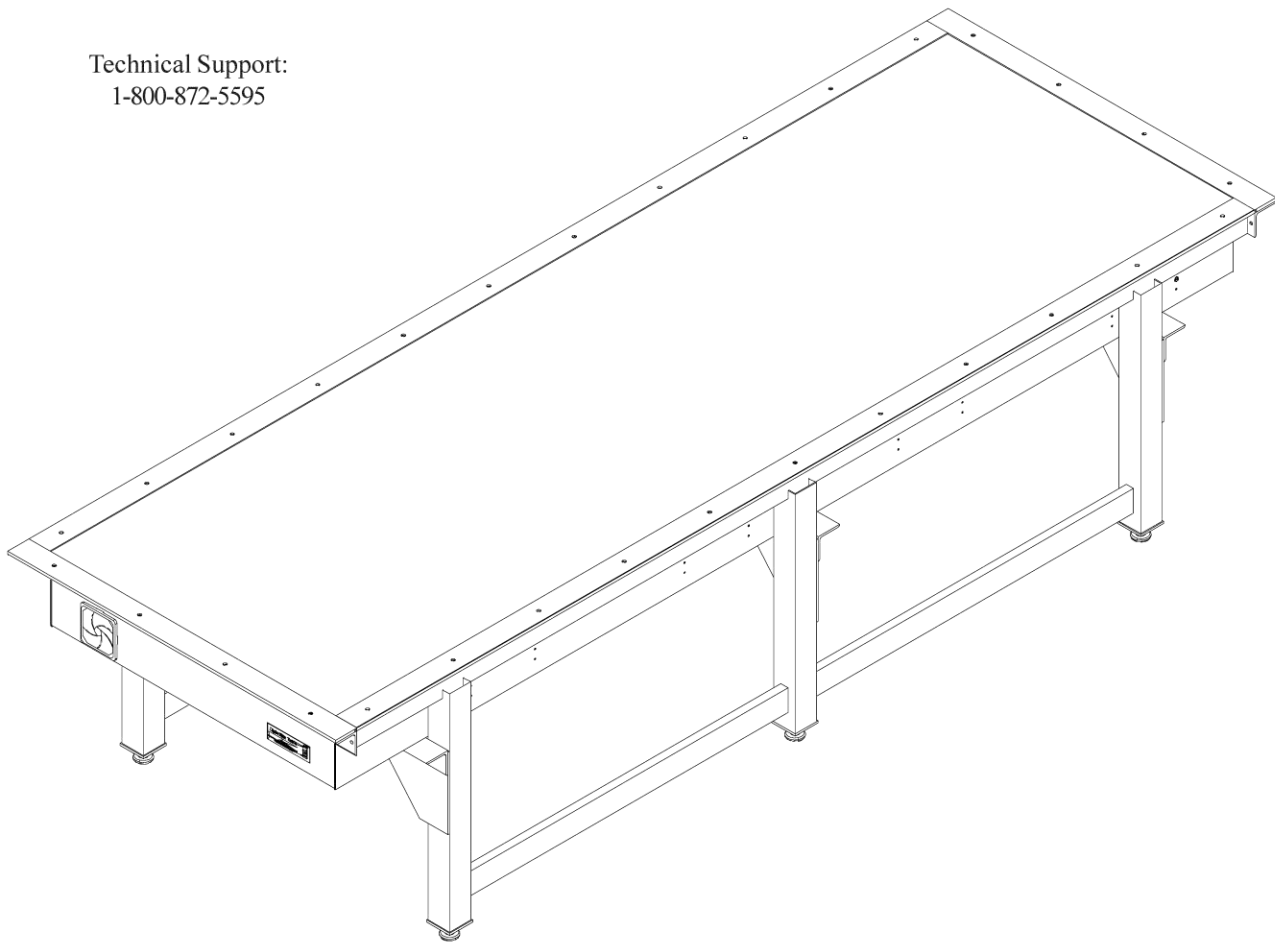

Eastman®

Over a Century of Cutting Expertise

Table of Contents

General Safety Precautions	3
Safety Information	3
Reference Manuals	4
Recommended Spare Parts List	4
Installation	4
Table Preparation	4
To Level Table	4
Electrical Connection	4
Operation	4
Bulb Replacement	4
Light Table Familiarization	5
Light Table	6
Camera Stand (Optional)	8
Light Box Enclosure	9
Light Box Electrical Diagram	10
Blue Print No. (31-9000-32)	10
Notes	11
Technical Data	12

IMPORTANT

The purchaser must instruct all operators on the proper use of this equipment. All standard industrial safety measures and equipment should be provided to protect the operator. Operators must be cautioned that improper or careless use of this equipment may cause personal injury. If you do not have qualified operators to instruct new persons, contact your EASTMAN sales representative or EASTMAN factory direct.

Electrical connections and servicing to this equipment should be made by a qualified electrician who is familiar with applicable codes and regulations. Disconnect this equipment from electrical power source before proceeding with any disassembly for adjustment or repair.

Safety Information

Throughout this manual, safety information is presented by the use of the terms WARNING, CAUTION, ELECTRICAL HAZARD, and NOTE. These terms have the following meanings:

WARNING

A warning contains critical information regarding potential safety hazards that can occur during proper use or misuse of the machine. Failure to follow these procedures may result in serious personal injury to the user.

CAUTION

A caution contains instructions for the use or maintenance of the machine. Failure to follow these procedures may result in damage to the machine.

ELECTRICAL HAZARD

An electrical hazard calls attention to a procedure, practice, or the like, which, if not correctly performed or adhered to, could result in personal injury. Do not proceed beyond an Electrical Hazard.

Supplementary information may be given in a Note.

General Safety Precautions

WARNING

- This machine is equipped with roller tubes. While advancing material keep hands, arms, and hair away from the roller tube area at all times. Safety gloves, glasses, and appropriate clothing may prevent serious personal injuries.
- Disconnect the power supply to the machine when it is not in use or during routine maintenance, including cleaning and lubrication.
- The purchaser must instruct all operators in the proper use of the machine according to the instructions in this manual. This training must include instruction on the potential safety hazards arising from the use or misuse of the machine. In addition to such training, the purchaser should provide written work instructions as necessary to ensure correct use of the machine for specific cutting and spreading applications.
- Do not modify this machine or disable safety features. Unauthorized modification may result in serious personal injuries to the user. Electrical connections to this machine must be made by a qualified electrician familiar with applicable codes and regulations.
- Safety labels must be kept clean and legible at all times. Call the Eastman Machine factory to order replacement labels.

Safety and Indemnification

During the life of the machine, the purchaser agrees to provide to all machine users (including its own employees and independent contractors) all relevant safety information, including warning labels and instruction manuals. The purchaser also agrees to maintain the safety features and working condition of the machine, and to adequately train all users in the safe use and maintenance of the machine. The purchaser agrees to defend, protect, indemnify, and hold Eastman Machine Company and its subsidiaries harmless from and against all claims, losses, expenses, damages, and liabilities to the extent that they have been caused by the purchaser's failure to comply with the terms and instructions of this manual.

Eastman®

Over a Century of Cutting Expertise

The Eastman **Light Table** has been inspected and tested at the factory prior to shipment. The Light Table may be shipped partially disassembled and require some assembly and setup before operation can take place. Refer to this service manual as an installation guide during installation. To get the best performance, familiarize yourself and all operators with all functions and adjustments of this equipment. Before any operation takes place it is important to carefully read and follow the instructions in this reference manual.

The Illustrated Parts List is a comprehensive list of the components used in the machine. When ordering replacement parts, please include machine name, machine voltage and serial number. Some machine configuration may require additional components not shown, please consult factory for part numbers.

The following list of recommended spare parts may be included with your machine or purchased at a later date.

Reference Manuals

E-552 Light Table Service Manual

Recommended Spare Parts List

<u>Part Number</u>	<u>Description</u>
11-1302	Fuse, 5 amp.
31-26260-1	Lamp, 36" T8
31-26261	Ballast, 110 volt

Installation

The Light Table weighs approx. 450 lbs. (204 kg.) uncrated for a 126" machine.



CAUTION

Do not place forklift arms under light box enclosure. When lifting, place forklift arms under table leg cross tubes. Use care not to damage table legs and leg levelers.

Table Preparation

Place light table approx. 12" [30.5 cm] from desired end of table and even with the operators side of the existing table. The table must be square and level along its entire length. A minimum 3 feet (1M) clearance along each side of the table is required for safe operation. Refer to familiarization section before placing machine in the final location.

To Level Table

Use carpenter's level to check table. Adjust table feet as necessary to level table.

Electrical Connection

Connect power cord plug to table inlet at back under side of the table. Check voltage rating with electrical rating stamped on serial number plate. If compatible, connect cord to main power.

Note: Voltage varying more than 10% (11v for 110 volt machine, 22v for 220 volt machine) may damage your system's electronics.

Operation

The Light Table is designed to aid the Camera in detecting the pattern outline by emitting light around the pattern.

The light switch is located at the table front. Press the light switch ON to turn on the light box and OFF to turn off the light box.

Bulb Replacement



CAUTION

Disconnect power before proceeding with bulb replacement.

Only Eastman bulbs should be used when replacing bulbs. Damage to your machine may result and will void your warrantee.

- 1) Disconnect main power.
- 2) Remove (4) screws holding the side dress plate.
- 3) Slide table surface out to gain access to the bulbs.



Always allow bulbs to cool before replacing.

- 4) Replace bulbs as required. It is always recommended to replace all the bulbs at the same time to ensure even light disbursement.
- 5) Replace table surface and side dress plate.

It is the owners responsibility to properly dispose of used bulbs according to the codes and regulations in your town.

Light Table Familiarization

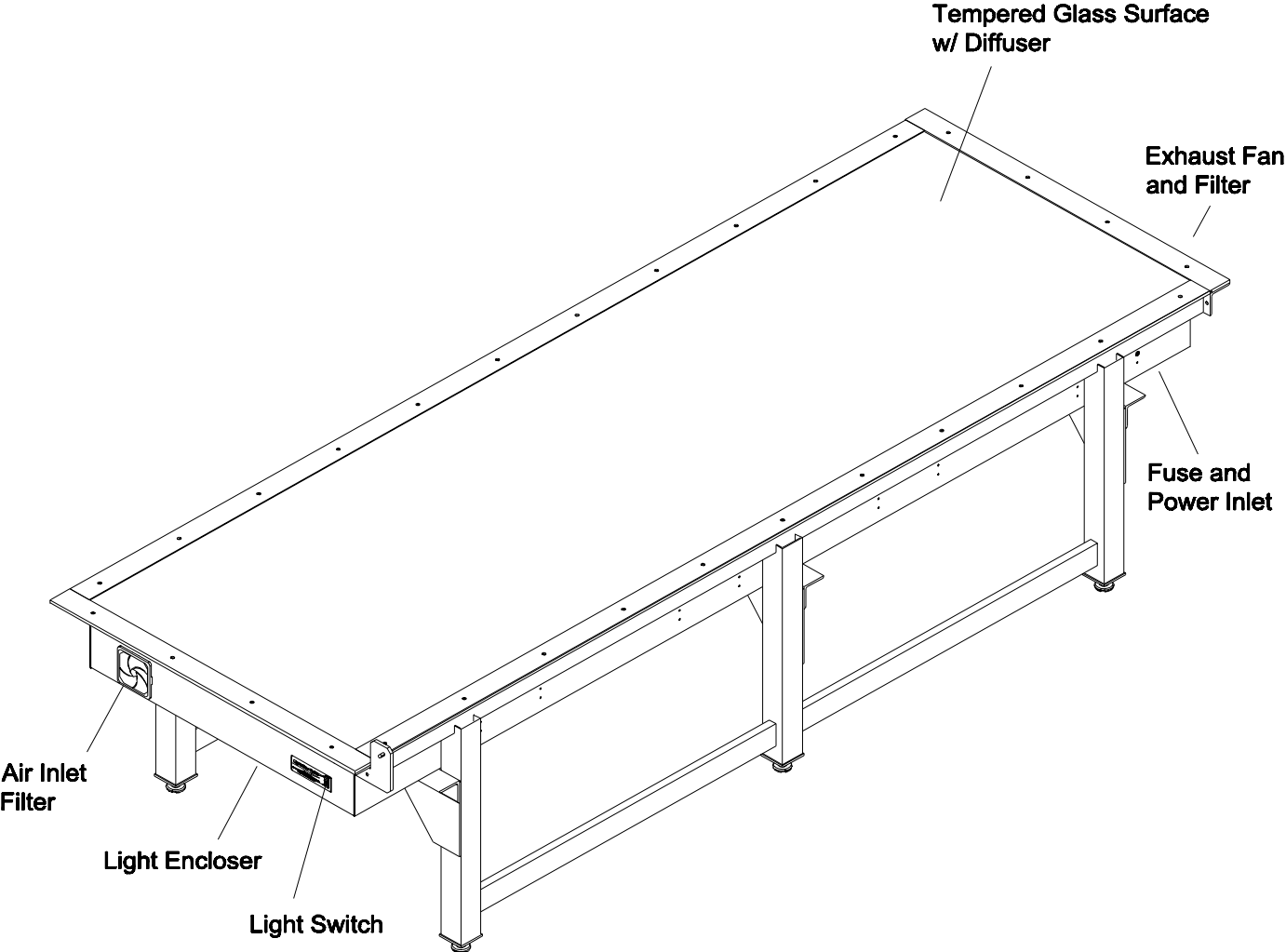
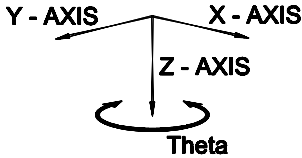

Eastman®

Over a Century of Cutting Expertise

Light Table

ITEM	PART NO.	DESCRIPTION	QTY.
1	333-34-8	Screw, Button Hd. 1/4-20 x 1/2	24
2	54-27058-MS	Dress Plate, Edge	2
3	54-27057-1	Dress Plate, Side, Wide	2
4	54-27062-1	Top Angle, Light Box, Wide	2
5	410-38	Washer, Flat 3/8	4
6	402-38	Washer, Lock 3/8	4
7	331-38-20	Screw, Hex Hd. 3/8-16 x 1-1/4	4
8	54-27065-MS	End Leg, Left, Light Box	1
9	54-27064-MS	End Leg, Right, Light Box	1
10	204-43	Nut, Hex 1/2-13	A/R
11	67-26237	Leg Leveler	A/R
12	203-38	Nut, Hex 3/8-16	8
13	402-38	Washer, Lock 3/8	8
14	410-38	Washer, Flat 3/8	16
15	335-38-20	Screw, Socket Hd. 3/8-16 x 1-1/4	8
16	54-27063-1	Bottom Angle, Light Box	A/R

MS-Machine Size

A/R - As Required

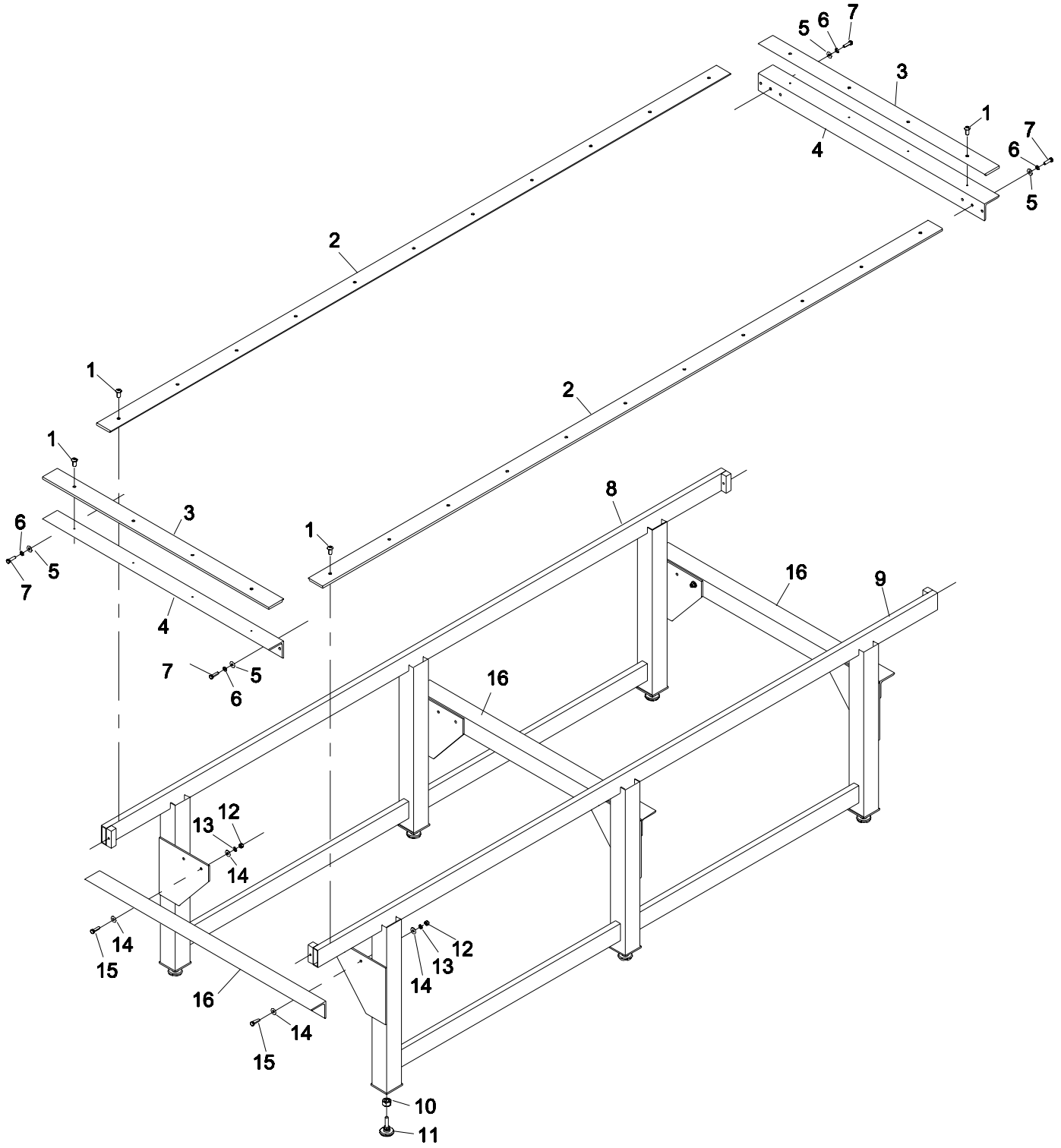

Eastman®

***Camera Stand
(Optional)***

Consult factory

Light Box Enclosure

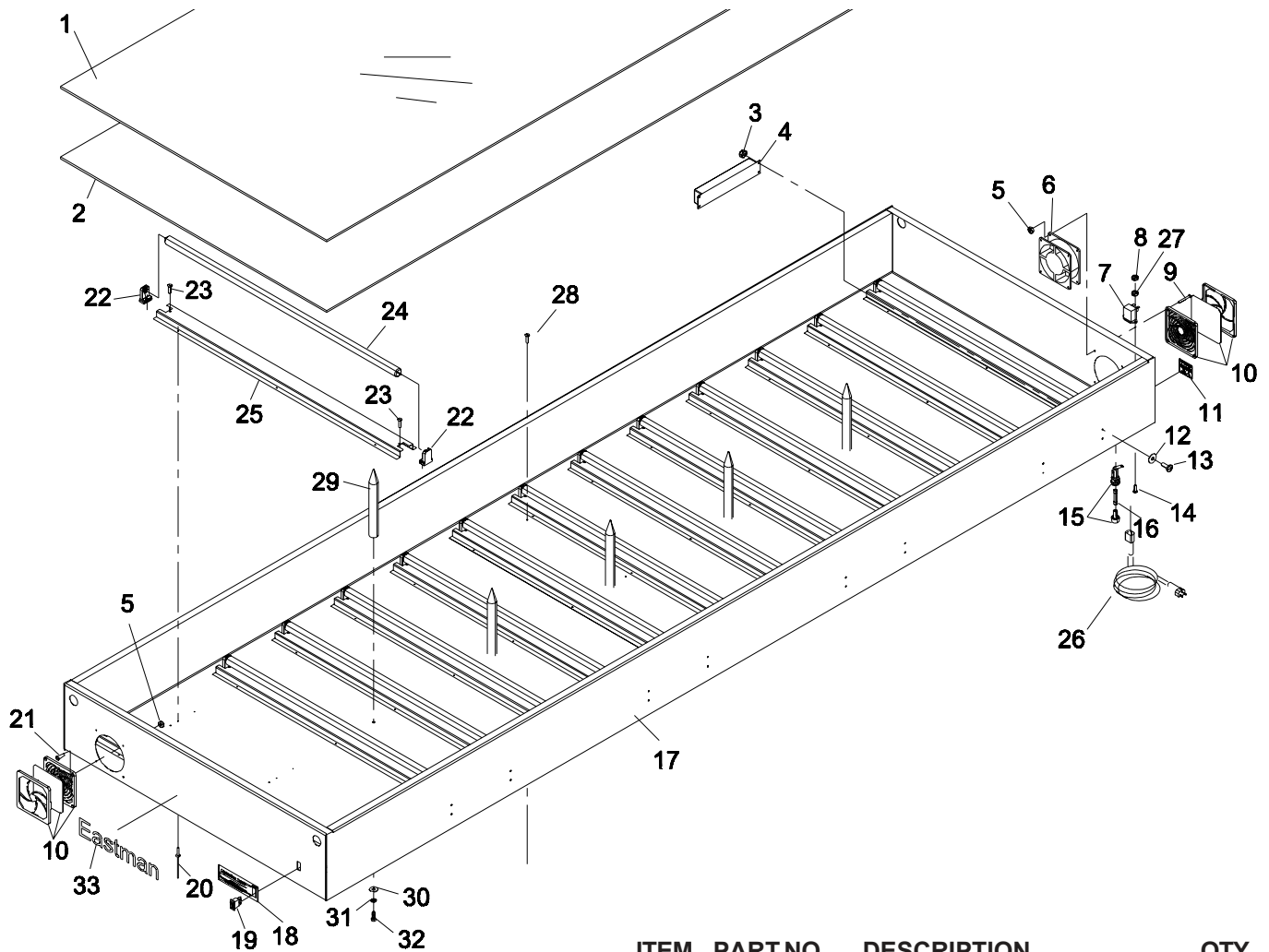

ITEM	PART NO.	DESCRIPTION	QTY.
1	67-26896-MS	Glass Surface	1
2	67-26554-1-MS	Inspection Surface	1
3	211-102	Nut, Elastic Stop #10-32	16
4	31-26261	Ballast, T8	A/R
5	203-86	Screw, Hex #6-32	8
6	11-1908	Fan, Air Cooling	1
7	253C1-1	Power Inlet, 110v	1
8	203-81	Nut, Hex #4-40	2
9	311-86-18	Screw, Flat Hd. #6-32 x 1-1/8	4
10	11-1958	Air Filter/Guard	2
11	91-26067	Decal, Voltage/Amp	1
12	410-010	Washer, Flat #10	16
13	311-102-8	Screw, Round Hd. #10-32 x 1/2	16
14	311-81-12	Screw, Flat Hd. #4-40 x 3/4	2
15	31-00741	Fuse Holder	1
16	11-1302	Fuse, 5 Amp.	1
17	54-27056-1-MS	Enclosure, Light Box	1
18	91-26085	Decal, Light Table	1
19	580C1-213	Switch, Light	1
20	546-4-8	Rivet, 1/8	52
21	311-86-8	Screw, Flat Hd. #6-32 x 1/2	4
22	11-1282	Lamp Holder	14
23	361-8-6	Screw, Self Tap #8 x 3/8	14
24	31-26260-1	Lamp, 36" T8	A/R
25	54-27066	Lamp Mounting Rail	A/R
26	145C1-9	Power Cord, 110v	1
27	402-040	Washer, Lock #4	2
28	373-93-8	Screw, Self Tap, #8 x 1/2	9
29	54-27120	Support Rod, Clear	4
30	410-36	Washer, Flat 5/16	4
31	402-36	Washer, Lock 5/16	4
32	331-36-10	Screw, Hex Head 5/16-18 x 5/8	4
33	91-26003	Decal, Eastman	2

MS-Machine Size
A/R-As Required

Eastman®

Over a Century of Cutting Expertise

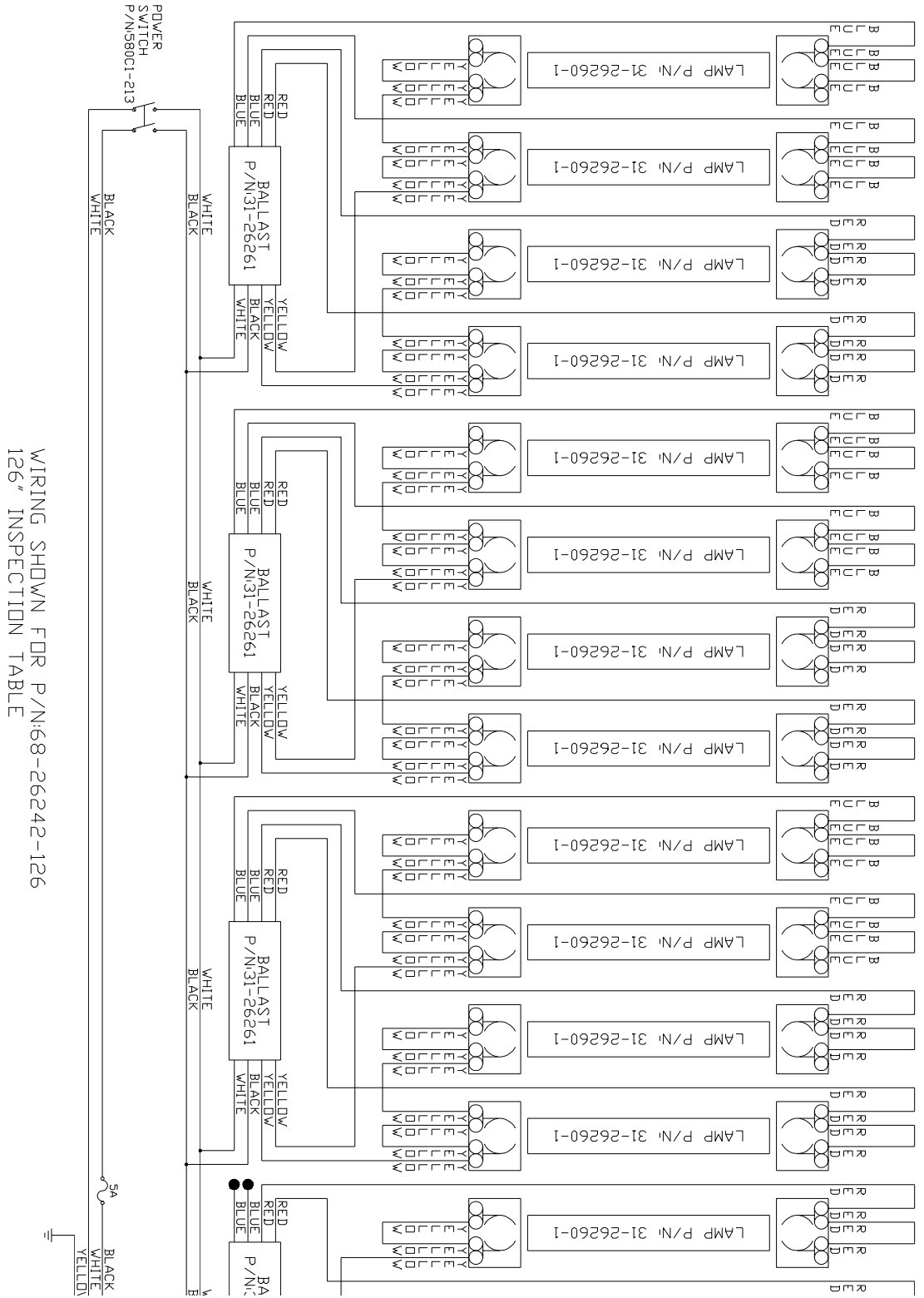

WIRING SHOWN FOR P/N: 68-26242-126
126" INSPECTION TABLE

Light Box Electrical Diagram
Blue Print No. (31-9000-32)

Notes

Eastman®

Over a Century of Cutting Expertise

Technical Data
EASTMAN® Light Table With Camera

Light Table

Table Height	33 in. (832 mm.)
Table Length	46 in. (1168 mm.)
Table Width	See Chart
Table Weight (126" Table)	450 lbs. (204kg.)
Operating Voltage	110v; 60hz
Power Requirement	110V/5A
Min. Start Temp.	0 F, -17 (C)
Lamp	36 in. T8
Kelvin Range	4100

Machine Size	Working Width	Overall Machine Width
66" (1676 mm)	48 x 66" (1219 mm x 1676 mm)	72" (1829 mm)
72" (1219 mm)	48 x 72" (1219 mm x 1829 mm)	78" (1981 mm)

Please allow 3 ft working clearance on all sides.
 * For all other sizes consult factory.

Limited Warranty. Eastman warrants to the buyer that the equipment shall be free from defects in materials or workmanship for a period of 180 days commencing on the date of invoice. Any goods or parts claimed by the buyer to be defective must be returned to Eastman, freight charges prepaid, within the 180-day warranty period. If Eastman determines that the goods or parts are defective in materials or workmanship, Eastman's sole obligation under this warranty shall be, at Eastman's sole option, to repair or replace the defective goods or parts or to provide the buyer a credit equal to the portion of the purchase price allocable to the defective goods or parts. This warranty shall not apply if defects are caused by product misuse or neglect, if the machine has been altered or modified by the buyer, or if other than genuine Eastman belts, emery wheels, knives or parts are used in the machine. THIS WARRANTY IS THE ONLY WARRANTY APPLICABLE TO THIS PURCHASE. SELLER DISCLAIMS ALL OTHER WARRANTIES, EXPRESS OR IMPLIED, INCLUDING, BUT NOT LIMITED TO, THE IMPLIED WARRANTIES OF MERCHANTABILITY AND FITNESS FOR A PARTICULAR PURPOSE.

Limitation of Liability. Eastman's liability to the buyer, and the buyer's remedies from Eastman, whether in contract, negligence, tort, under any warranty or otherwise, shall be limited to the remedies provided in the foregoing Limited Warranty. In no event shall Eastman have any responsibility or liability to the buyer for (a) any special, indirect, incidental, or consequential damages, including, but not limited to, loss of use, revenue, or profit, even if Eastman has been advised of the possibility of such damages, or (b) any claim against the buyer by any third party. The price stated for the product sold is a consideration for limiting Eastman's liability.