

## 1525

## 1526

Teilleiste

Parts list

Liste de pièces

Lista de piezas

Diese Teilleiste hat für Maschinen ab nachfolgender  
Seriennummer Gültigkeit:

This parts list applies to machines from the following  
serial numbers onwards:

Cette liste de pièces est valable pour les machines au  
numéros de série à partir de:

Esta lista de piezas tiene validez para máquinas a partir del  
número de serie siguiente:

# 2572934



Alle Informationen und Abbildungen waren zum Zeitpunkt der Druckgebung auf dem neusten Stand.

Technische Änderungen vorbehalten!

Der Nachdruck, die Vervielfältigung sowie die Übersetzung - auch auszugsweise - aus PFAFF-Teilelisten ist nur mit unserer vorherigen Zustimmung und mit der Quellenangabe gestattet.

At the time of printing, all information and illustrations contained in this document were up to date.

Subject to alteration!

The reprinting, copying or translation of PFAFF Parts lists whether in whole or in part, is only permitted with our previous permission and with written reference to the source.

Au moment de la remise à l'imprimeur, toutes les informations et figures se rapportant à cette machine correspondaient à l'état actuel des connaissances.

Sous réserve de modifications techniques!

Aucune reproduction, polycopie ou traduction - même par extraits - des listes de pièces PFAFF ne peut être effectuée, à condition d'en indiquer l'origine, sans notre autorisation expresse.

Todas las informaciones e ilustraciones de este manual estaban al día en el momento de entregarse para su impresión.

¡ Salvo modificaciones técnicas!

La reimpresión, reproducción y traducción - aunque sólo sea parcial - de las listas de piezas PFAFF sólo está permitida con nuestro permiso previo e indicando la fuente.

## **PFAFF Industrie Maschinen GmbH**

Postfach 3020

D-67653 Kaiserslautern

Königstr. 154

D-67655 Kaiserslautern

Redaktion/Illustration

**Verlag Technische Dokumentation**

Postfach 1106

D-77901 Lahr

	Seite Page Page Página
<b>0</b> <b>Wichtiger Hinweis</b> .....	<b>0 - 1</b>
Important note	
Avis important	
Observación importante	
<b>1</b> <b>Vorwort</b> .....	<b>1 - 1</b>
Foreword	
Avant-propos	
Notas preliminares	
<b>2</b> <b>Erläuterungen der Schlüsselzeichen</b> .....	<b>2 - 1</b>
Explanation of key markings	
Explication des symboles	
Explicaciones de los signos clave	
<b>3</b> <b>Basismaschine</b>	
Basic machine	
Machine de base	
Máquina básicas	
<b>3.01</b> <b>Gehäuseteile</b> .....	<b>3 - 1</b>
Housing sections	
Parties du corps	
Piezas del cárter	
<b>3.02</b> <b>Kopfteile</b> .....	<b>3 - 2</b>
Needle head parts	
Pièces de tête	
Piezas de la cabeza	
<b>3.03</b> <b>Armteile</b> .....	<b>3 - 9</b>
Arm parts	
Pièces de bras	
Piezas del brazo	
<b>3.04</b> <b>Grundplattenteile</b> .....	<b>3 - 14</b>
Bedplate parts	
Pièces du plateau fondamental	
Piezas del cárter	
<b>4</b> <b>Kanten-Beschneideeinrichtung (-731/02)</b> .....	<b>4 - 1</b>
Edge trimmer (-731/02)	
Couteau (-731/02)	
Recortador (-731/02)	

		Seite Page Page Página
5	<b>Greifersystem mit Anhaltenocken an der Stichplatte (-901/01)</b> ..... 5 - 1 Gripper system with stop cam on the stitching plate (-901/01) Système crochet avec mentonnet de retenue à la plaque à aiguille (-901/01) Sistema de agarre con levas de parada en la placa de aguja (-901/01)	
6	<b>Presserfuß-Automatik (-910/04)</b> ..... 6 - 1 Automatic presser foot lifter (-910/04) Relève-pied automatique (-910/04) Grupo acondicionador del aire comprimido (-910/04)	
7	<b>Verriegelungs-Einrichtung (-911/35)</b> ..... 7 - 1 Backtacking mechanism (-911/35) Dispositif à points d'arrêt (-911/35) Rematador (-911/35)	
8	<b>Schalteinrichtung (-918/29)</b> ..... 8 - 1 Switching system (-918/29) Dispositif de commande (-918/29) Mecanismo de mando (-918/29)	
9	<b>Wartungseinheit (-925/03)</b> ..... 9 - 1 Air filter / lubricator (-925/03) Conditionneur d'air comprimé (-925/03) Grupo acondicionador del aire comprimido (-925/03)	
10	<b>Spulensfadenvorratswächter (-926/06)</b> ..... 10 - 1 Bobbin thread supply monitor (-926/06) Contrôleur de canette (-926/06) Detector del hilo de la canilla (-926/06)	
11	<b>Pneumatische Ausrüstung</b> ..... 11 - 1 Pneumatic equipment Equipement pneumatique Equipo neumático	
12	<b>Elektrische Ausrüstung</b> Electrical equipment Equipement électrique Equipo eléctrico	
12.01	<b>Kabelbaum zum Oberteil</b> ..... 12 - 1 Cable tree to sewing head Faisceau de câbles vers la tête de machine Mazo de cables para el cabezal	

	Seite Page Page Página
12.02 Tastschalter ..... Push-button Interrupteur à bouton-poussoir Interruptor pulsador	12 - 2
12.03 Bedienfeld ..... Control panel Panneau de commande Panel de mandos	12 - 3
12.04 Positionsgeber ..... Synchronizer Synchronisateur Sincronizador	12 - 4
12.05 Sollwertgeber ..... Set-point generator Codeur Emisor del valor teórico	12 - 4
12.06 Motordreh­schalter ..... Motor turn switch Interrupteur rotatif Interruptor giratorio	12 - 5
12.07 Knieschalter mit Leitung ..... Knee switch with cable Interrupteur de genouillère avec câble Interruptor de rodillera con cable	12 - 5
12.08 Steuergerät ..... Control device Boîte de commande Caja de mandos	12 - 6
13 Garnrollen­ständer ..... Reel stands Porte-bobines Portacarretes	13 - 1
14 Einstellehren ..... Adjustment gauges Calibres Calibres de ajuste	14 - 1

	Seite Page Page Página
<b>15</b> Teile zur Tischplatte ..... 14 - 1 Parts for table top Pièces du plateau Piezas para el tablero	
<b>16</b> Keilriemen ..... 16 - 1 V-belt Courroie trapézoïdale Correa trapezoidal	
<b>17</b> Schmiermittel-Übersicht ..... 17 - 1 Overview of lubricants Tableau de lubrifiants Tabla de lubricantes	
<b>18</b> Index (Teilenummern / Seitenzahlen) ..... 18 - 1 Index (part numbers / page numbers) Index (numéros de pièces, de pages) Index (números de pieza / números de página)	
<b>19</b> Unterklassen-Ausstattung Subclass parts Composition des sous-classes Composición de las subclases	
<b>19.01</b> Nähwerkzeuge (PFAFF 1525) ..... 19 - 2 Gauge parts (PFAFF 1525) Organes de couture (PFAFF 1525) Organos de costura (PFAFF 1525)	
<b>19.02</b> Nähwerkzeuge (PFAFF 1526) ..... 19 - 26 Gauge parts (PFAFF 1526) Organes de couture (PFAFF 1526) Organos de costura (PFAFF 1526)	

### Achtung!



Wir machen ausdrücklich darauf aufmerksam, daß Ersatz- und Zubehörteile, die nicht von uns geliefert werden, auch nicht von uns geprüft und freigegeben sind. Der Einbau und / oder die Verwendung solcher Produkte kann daher u. Umständen konstruktiv vorgegebene Eigenschaften Ihrer Maschine negativ verändern. Für Schäden, die durch die Verwendung von Nicht-Originalteilen entstehen, übernehmen wir keine Haftung!

### Caution!



We warn you expressively that spare parts and accessories that are not supplied by us are not tested and released by us. Fitting or using these products may therefore have negative influences on features that depend on the machine design. We are not liable for any damage caused by the use of non-Pfaff parts!

### Attention!



Nous attirons expressément votre attention sur le fait que les pièces de rechange et accessoires qui n'ont pas été livrés par nous n'ont pas non plus été contrôlés et agréés par nous. C'est pourquoi le montage et/ou l'utilisation de telles pièces peut éventuellement entraîner l'altération des caractéristiques de construction de votre machine. Par conséquent, nous n'assumons aucune responsabilité pour les dommages causés par l'emploi de pièces qui ne sont pas d'origine!

### ¡Atención!



Se hace observar que en el caso de piezas de recambio y accesorios que no hayan sido suministrados por nosotros, quiere decir que non han sido sometidas por nuestra parte a un control y que no se les ha dado el visto bueno. Por esta razón, el montaje y/o empleo de tales productos puede repercutir negativamente en las características previstas en su máquina. ¡Para los daños que eventualmente pudiesen presentarse al utilizar piezas no originales, no asumimos ninguna garantía!

- Die Seriennummer der Maschine, für die diese Teileliste Gültigkeit hat, ist auf der Titelseite aufgeführt.
  - Alle Teile sind so abgebildet, wie sie in der Maschine funktionsmäßig zusammengehören.
  - Gestrichelt dargestellte Teile zeigen angrenzende Teile aus anderen Funktionsgruppen.
  - Im oberen Teil der Bildseiten befindet sich eine Gesamtansicht der Maschine.
  - Der Einbauort der dargestellten Teile wird durch eine gerasterte Fläche gekennzeichnet.
  - Einrahmungen auf den Bildseiten zeigen, aus welchen Einzelteilen sich die Gruppenteile zusammensetzen.
  - Die auf den Bildseiten verwendeten Schlüsselzeichen (  ;  2 ;  3 usw.) sind im Kapitel "Erläuterungen der Schlüsselzeichen" aufgelistet.
- 
- The serial number of the machine to which this parts list applies is indicated on the cover page.
  - All parts are illustrated in function groups with the parts which they function together with in the machine.
  - Parts illustrated with broken lines are parts from other function groups which border on the illustrated function group.
  - The above section of the page of illustrations contains a total view of the machine. The place for the installation of the parts pictured here is marked by the grid.
  - The framed-in sections on the illustration pages show the individual parts comprising a group.
  - The key markings used on the illustrated pages (  ;  2 ;  3 etc.) are listed in the chapter "Explanation of key markings".
- 
- Le numéro de série de la machine pour laquelle cette liste de pièces est valable est indiqué sur la première page.
  - Toutes les pièces sont représentées en fonction de leur groupement fonctionnel dans la machine.
  - Les pièces hâchurées indiquent les pièces limitrophes de groupes de fonctions différents.
  - La partie supérieure des pages de figures comprend une présentation globale de la machine. L'emplacement des pièces représentées est signalé par quadrillages.
  - Les parties encadrées sur les pages à illustrations représentent les pièces individuelles formant groupe.
  - Vous trouverez au chapitre "Explication des symboles" une liste des symboles utilisés sur les pages de figures (  ;  2 ;  3 etc.)
- 
- El número de serie de la máquina para la cual tiene validez esta lista de piezas va indicado en la página de título.
  - Todas las piezas están ilustradas tal como aparecen en la máquina para su funcionamiento.
  - Las piezas representadas con rayitas muestran piezas colindantes de otros grupos de funciones.
  - En la parte superior de las páginas ilustradas se puede ver una vista en conjunto de la máquina.
  - El lugar de montaje de la pieza representada va caracterizada mediante una superficie reticulada.
  - Los recuadros en las páginas ilustradas indican las piezas individuales de que se componen los grupos.
  - Los signos clave (  ;  2 ;  3 etc.) empleados en las páginas con ilustraciones van listados en el capítulo "Explicaciones de los signos clave".



	<b>Unterklassenabhängig, Teilenummer siehe Unterklassen-Ausstattung.</b> Subclas-dependent, for part number see subclass parts listing. Fonction de la sous-classe; pour le numéro de la pièce, voir "Equipement de sous-classes". Dependientes de la subclase, para el número de pieza véase "Dotación de subclases".
<b>B</b>	<b>Maschinen-Ausstattung für mittlere Materialien.</b> Model B for sewing thin and medium-weight materials. Modèle B pour la couture de matières moyennes. Tipo B para materiales semiligeros.
<b>C</b>	<b>Maschinen-Ausstattung für mittelschwere Materialien.</b> Model C for sewing medium-heavy materials. Modèle C pour la couture de matières mi-lourdes. Tipo C para materiales semipesados.
<b>C/D</b>	<b>Maschinen-Ausstattung wie C; jedoch mit größerem Stichloch ( 2,6 mm).</b> Machine equipped as model C, but with larger needle hole ( 2.6 mm). Machine prévue comme en C, mais avec trou d'aiguille plus grand ( 2,6 mm). Tipo de máquina como C, pero con agujero de la placa de aguja má grande ( 2,6 mm).
<b>N</b>	<b>Stichlänge 6,0 mm.</b> Stitch length 6.0 mm. Longeur du point 6,0 mm. Largo de puntada 6,0 mm.
<b>N8</b>	<b>Stichlänge 8,0 mm.</b> Stitch length 8.0 mm. Longeur du point 8,0 mm. Largo de puntada 8,0 mm.
<b>3</b>	<b>Geklebt</b> Part cemented Pièce collée Pieza pegada
<b>3/1</b>	<b>Gesichert mit Loctite</b> Secured with Loctite Bloqué par Loctite Asegurado con loctite
<b>3/4</b>	<b>Selbstklebend</b> Self-adhesive Auto-adhésive Autoadhesivo

- 6** **Nadeldicke und Spitzenform bei Bestellung angeben.**  
Needle size and style of point to be stated on order.  
Préciser la grosseur de l'aiguille et la forme de la pointe à la commande.  
Grosor de aguja y forma de la punta, indíquese en los pedidos.
- 10** **Nadelabstand**  
Needle gauge  
Ecartement des aiguilles  
Distancia entre agujas
- 27/2** **Eingeklammerte Zahl = Dicke in mm.**  
Number in brackets = thickness in mm.  
Chiffre entre parenthèses = épaisseur en mm.  
Cifra entre paréntesis = espesor en mm.
- 28/1** **Sonderausführung mit Spulenkapsel**  
Special model with bobbin case  
Version spéciale avec boîte à canette  
Modelo especial con caja de bobina
- 32/1** **Beim Einbau dieses Teiles ist Nacharbeit erforderlich.**  
When fitting this part re-work is required.  
Retouches nécessaires au montage.  
Al montar esta pieza hay que retocarla antes.
- 40/2** **Tränken mit 28-011 201-44; Bestellnummer siehe Seite 17 - 1.**  
Soak with 28-011 201-44; for part number see page 17 - 1.  
Imbiber d'huile 28-011 201-44; n° de commande, voir page 17 - 1.  
Empage con aceite 28-011 201-44; para el número de pedido véase la página 17 - 1.
- 40/3** **Fetten mit 28-011 202-47; Bestellnummer siehe Seite 17 - 1.**  
Grease with 28-011 202-47; for part number see page 17 - 1.  
Graisser avec de la graisse 28-011 202-47; n° de commande, voir page 17 - 1.  
Engrase con grasa 28-011 202-47; para el número de pedido véase la página 17 - 1.
- 40/4** **Fetten mit 28-011 202-43; Bestellnummer siehe Seite 17 - 1.**  
Grease with 28-011 202-43; for part number see page 17 - 1.  
Graisser avec de la graisse 28-011 202-43; n° de commande, voir page 17 - 1.  
Engrase con grasa 28-011 202-43; para el número de pedido véase la página 17 - 1.
- 40/5** **Ölenn mit 28-011 201-44; Bestellnummer siehe Seite 17 - 1.**  
Oil with 28-011 201-44; for part number see page 17 - 1.  
Huiler avec de la graisse 28-011 201-44; n° de commande, voir page 17 - 1.  
Lubrifique con grasa 28-011 201-44; para el número de pedido véase la página 17 - 1.

- 40/13**      **Fetten mit 28-011 202-05; Bestellnummer siehe Seite 17 - 1.**  
Grease with 28-011 202-05; for part number see page 17 - 1.  
Graisser avec de la graisse 28-011 202-05; n° de commande, voir page 17 - 1.  
Engrase con grasa 28-011 202-05; para el número de pedido véase la página 17 - 1.
- 60**      **Wahlweise**  
Optional  
Au choix  
Opcional
- 81/3**      **Verwendung je nach Bedarf.**  
To be used as required.  
Utilisation en fonction des besoins.  
Utilización según sea necesario
- 90/1**      **Für Wechselstrom**  
For single-phase A.C.  
Pour du courant alternatif  
Para corriente alterna monofásica
- 95/8**      **X-Werte bei Bestellung angeben.**  
Please state x-values on order.  
Indiquer les valeurs "x" à la commande.  
Indíquese en los pedidos los valores "x".
- 96**      **Länge angeben**  
State length  
Préciser longueur  
Indíquese la largura

# PFAFF

**G.M. PFAFF  
Aktiengesellschaft**

Postfach 3020  
D-67653 Kaiserslautern

Königstr. 154  
D-67655 Kaiserslautern

Telefon: (0631) 200-0  
Telefax: (0631) 172 02  
Telex: 45753 PFAFF D

Gedruckt in der BRD  
Printed in Germany  
Imprimé en R.F.A.  
Impreso en la R.F.A.

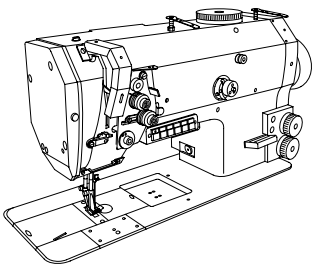

Gehäuseteile  
Housing sections  
Parties du corps  
Piezas del cárter

PFAFF 1525-900/81;-900/82  
PFAFF 1526-900/81

3.01

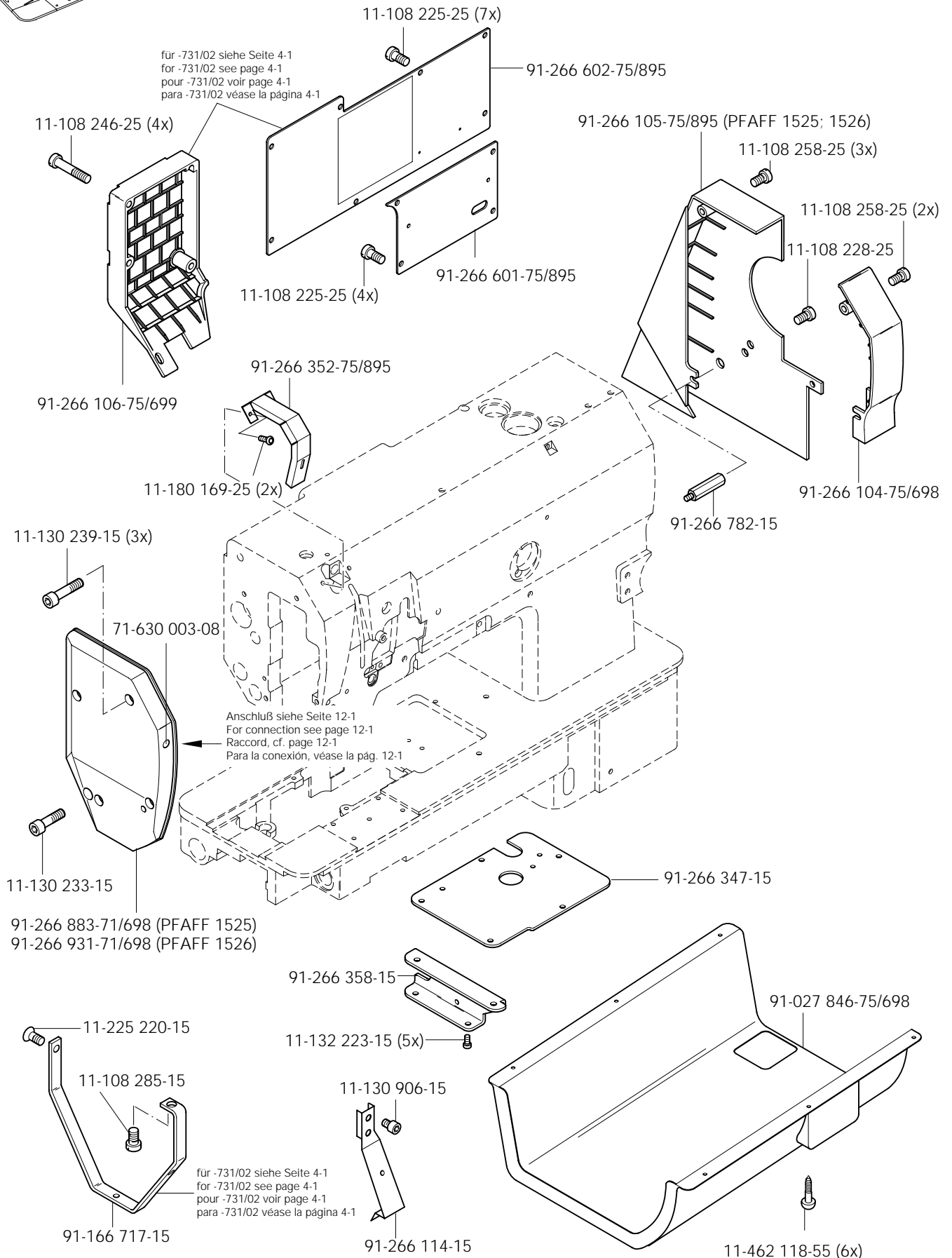

# 3.02

## Kopfteile Needle head parts Pièces de tête Piezas de la cabeza

PFAFF 1525-900/81;-900/82  
PFAFF 1526-900/81

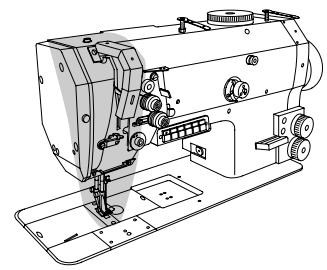

91-166 393-01  
für -731/02 siehe Seite 4-2  
for -731/02 see page 4-2  
pour -731/02 voir page 4-2  
para -731/02 véase la página 4-2

11-341 904-15 (3x)

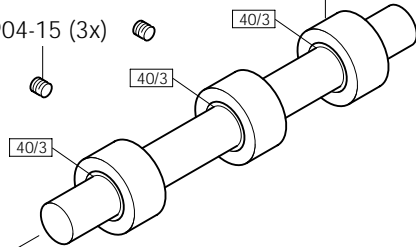

91-266 258-91  
für -731/02 siehe Seite 4-2  
for -731/02 see page 4-2  
pour -731/02 voir page 4-2  
para -731/02 véase la página 4-2

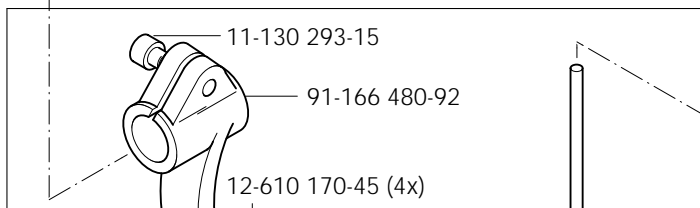

91-166 485-01

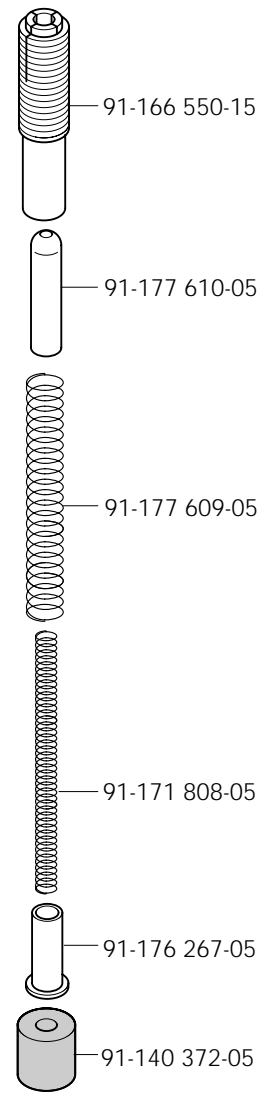

91-166 550-15

91-177 610-05

91-177 609-05

91-171 808-05

91-176 267-05

91-140 372-05

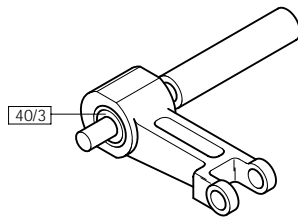

91-266 326-05

91-176 178-05

91-266 277-01

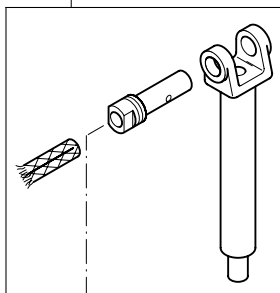

91-266 172-05

91-166 487-05 (2x)

91-266 173-05

91-176 192-05

91-069 062-05 (6x)

91-266 325-05 (2x)

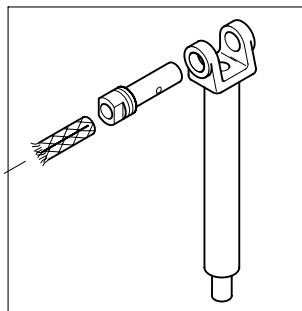

91-166 997-01

91-266 334-05 (2x)

91-266 400-05 (2x)

für -731/02 siehe Seite 4-2  
for -731/02 see page 4-2  
pour -731/02 voir page 4-2  
para -731/02 véase la página 4-2

91-166 518-15 (2x)

11-130 089-15 (2x)

11-130 173-15 (4x)

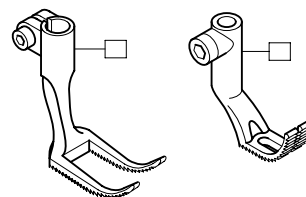

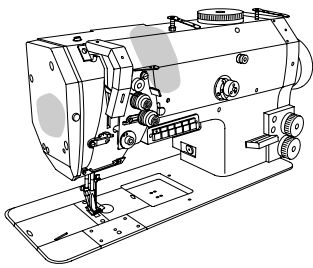

Kopfteile  
 Needle head parts  
 Pièces de tête PFAFF 1525-900/81;-900/82  
 Piezas de la cabeza PFAFF 1526-900/81

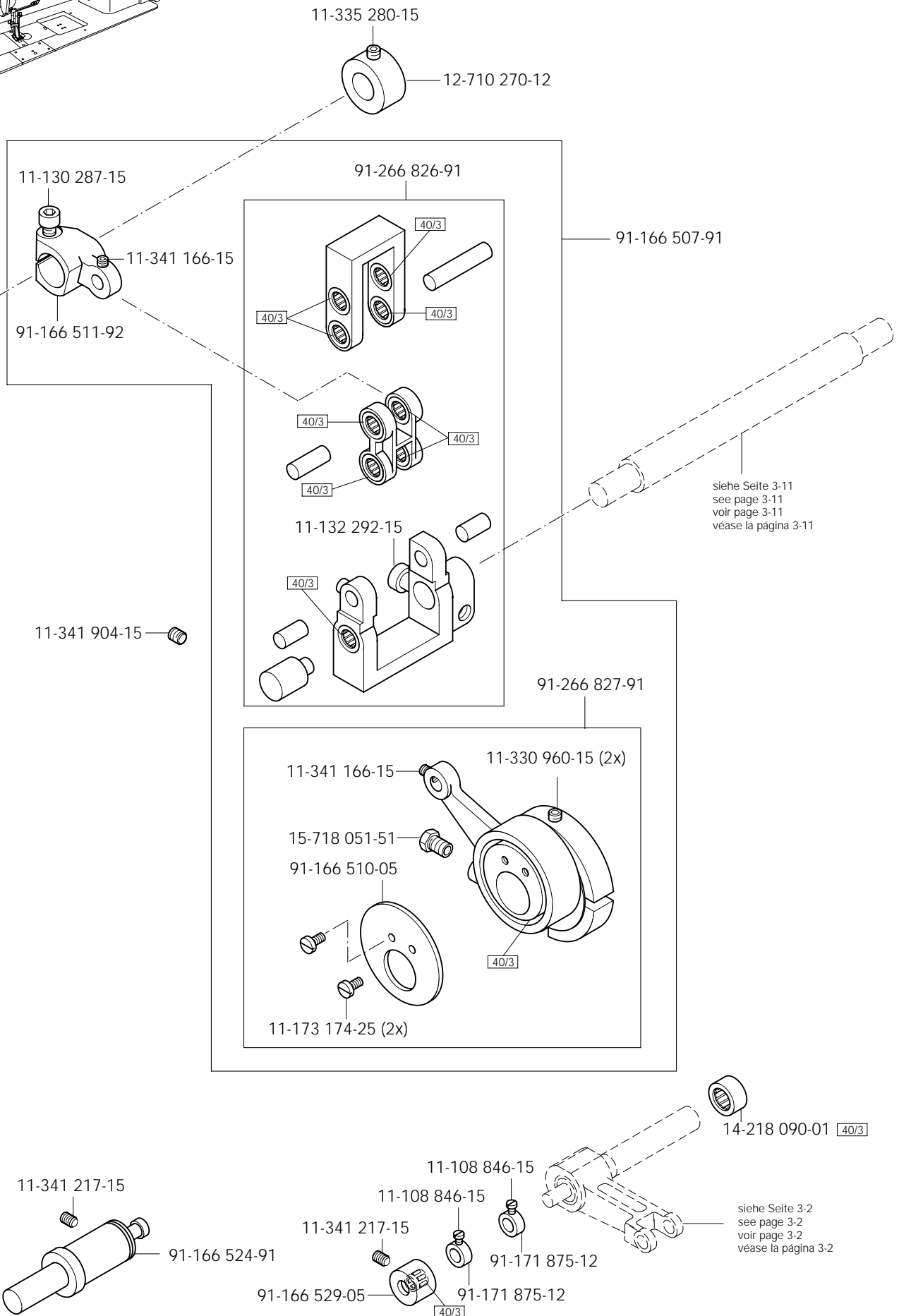

# 3.02

Kopfteile  
 Needle head parts  
 Pièces de tête  
 Piezas de la cabeza PFAFF 1525-900/81;-900/82

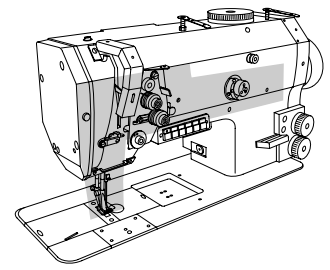

siehe Seite 3-12  
 see page 3-12  
 voir page 3-12  
 véase la página 3-12

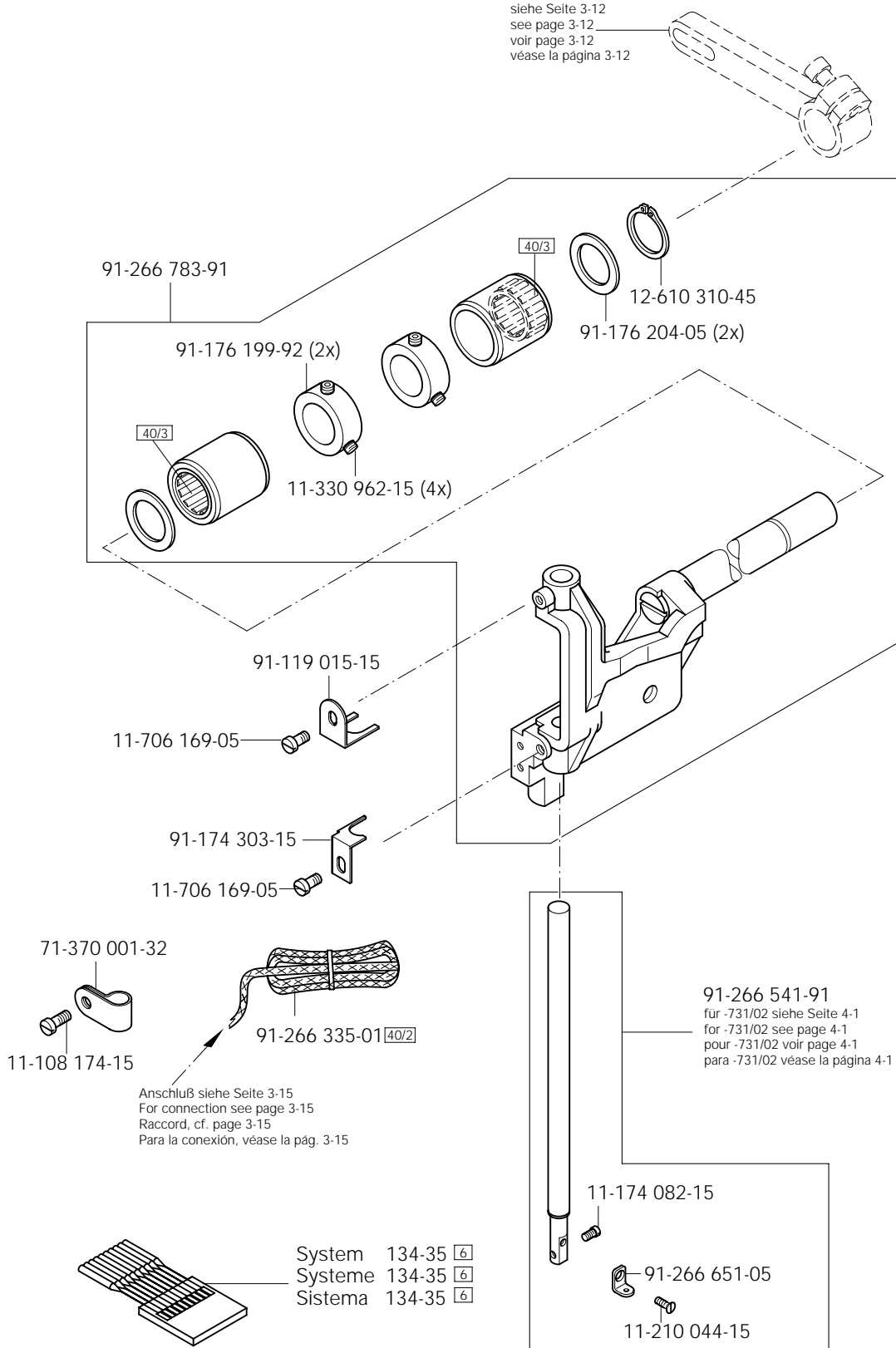



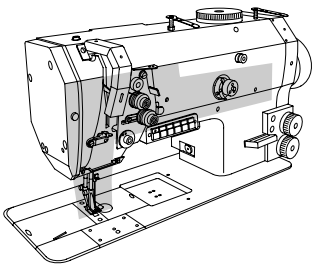

Kopfteile  
 Needle head parts  
 Pièces de tête  
 Piezas de la cabeza PFAFF 1526-900/81

3.02

siehe Seite 3-12  
 see page 3-12  
 voir page 3-12  
 véase la página 3-12

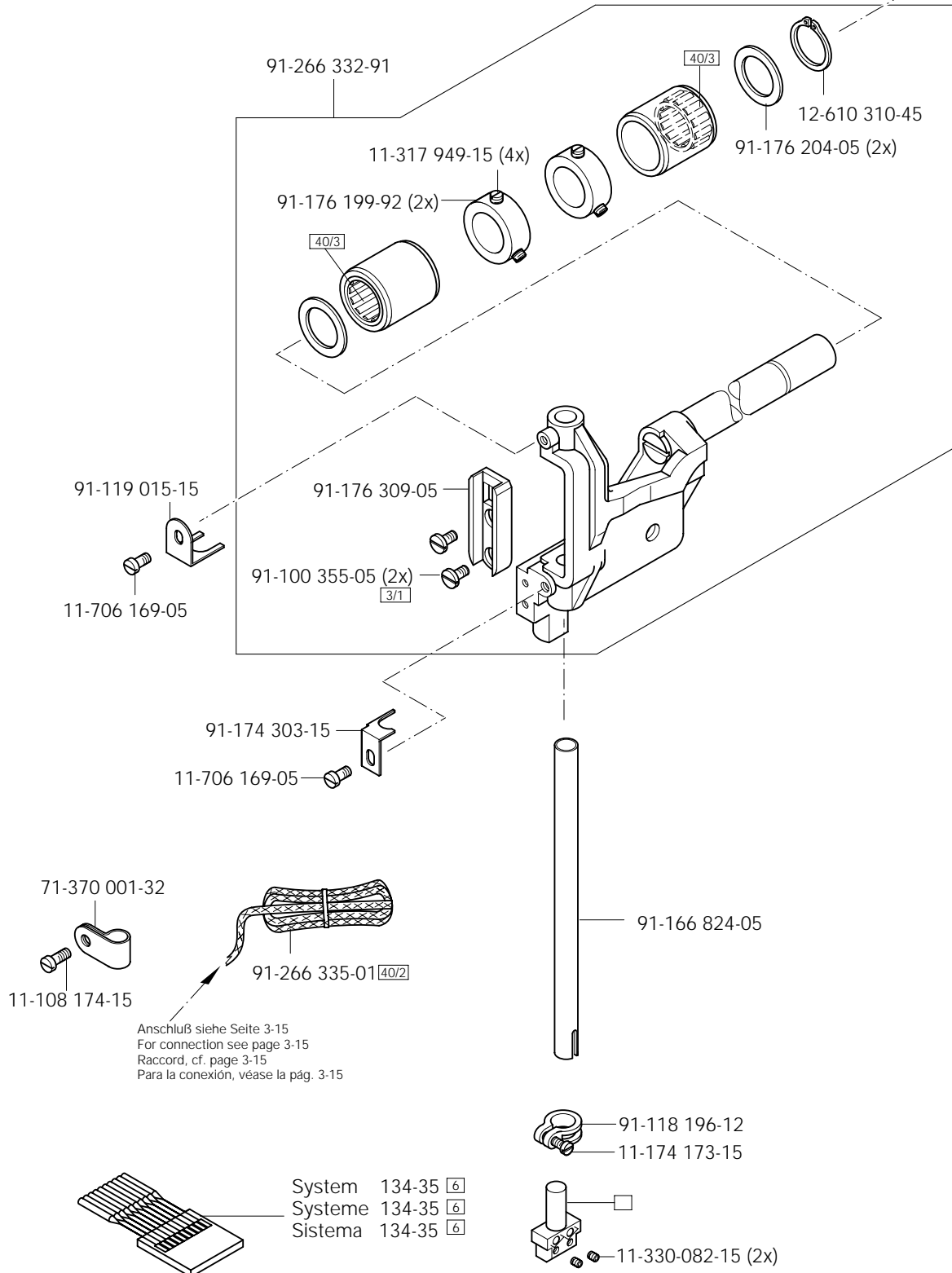

# 3.02

Kopfteile  
Needle head parts  
Pièces de tête  
Piezas de la cabeza

PFAFF 1525-900/81;-900/82  
PFAFF 1526-900/81

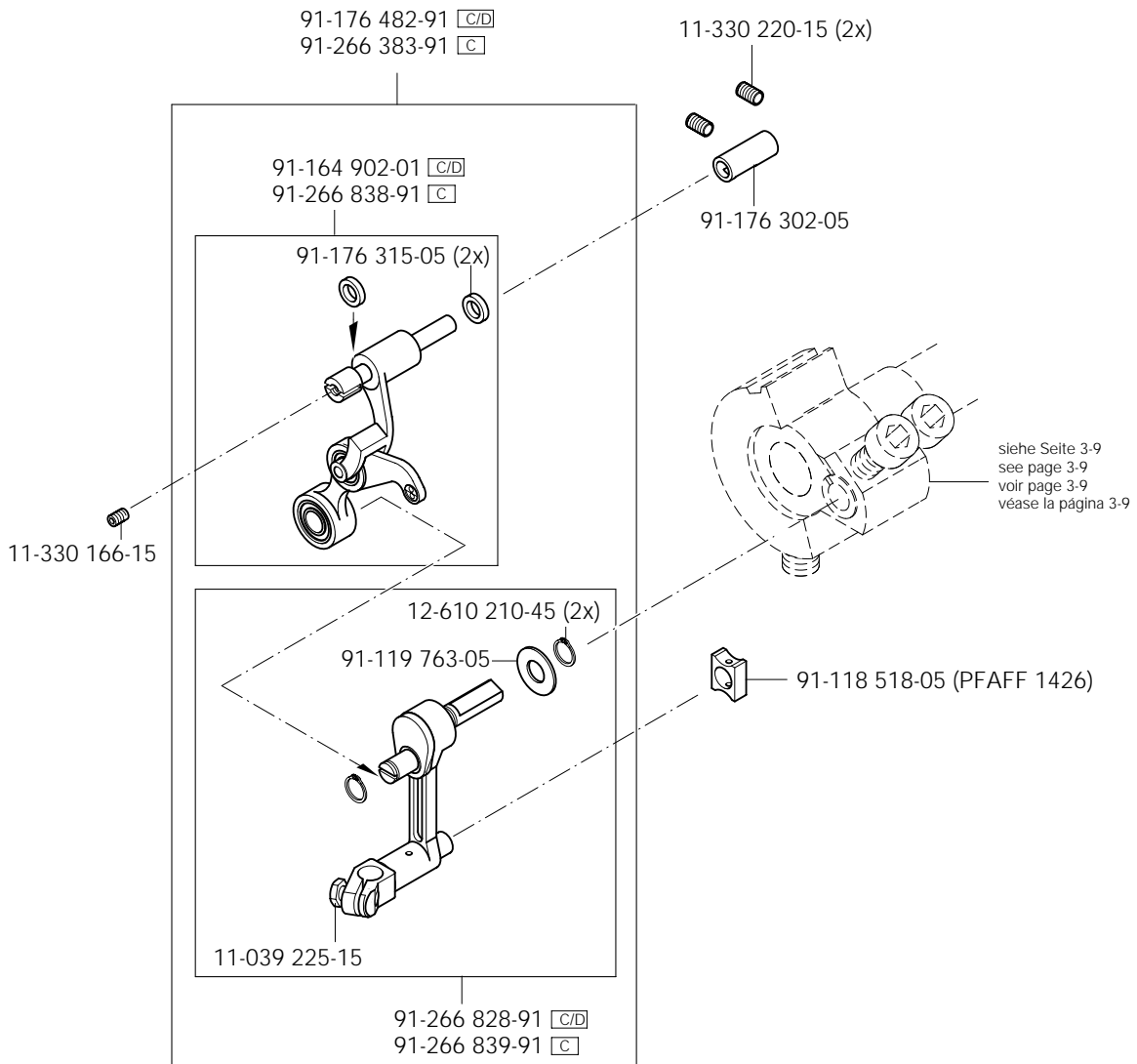
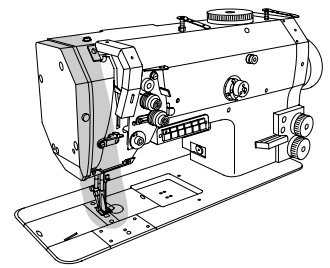

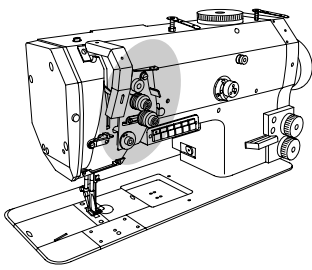

### Kopfteile

Needle head parts

Pièces de tête

Piezas de la cabeza

PFAFF 1525-900/81;-900/82

PFAFF 1526-900/81

# 3.02

Anschluß siehe Seite 12-1  
 For connection see page 12-1  
 Raccord, cf. page 12-1  
 Para la conexión, véase la pág. 12-1

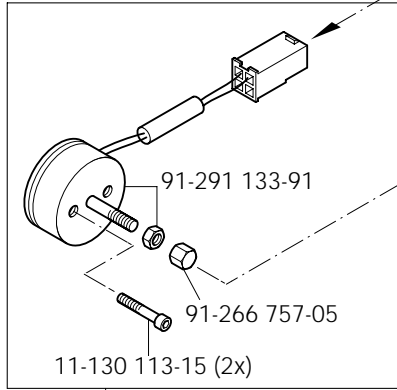

91-266 540-91 für -731/02 siehe Seite 4-3  
 for -731/02 see page 4-3  
 pour -731/02 voir page 4-3  
 para -731/02 véase la página 4-3

91-266 440-71/698 } (PFAFF 1525)  
 91-266 465-71/698

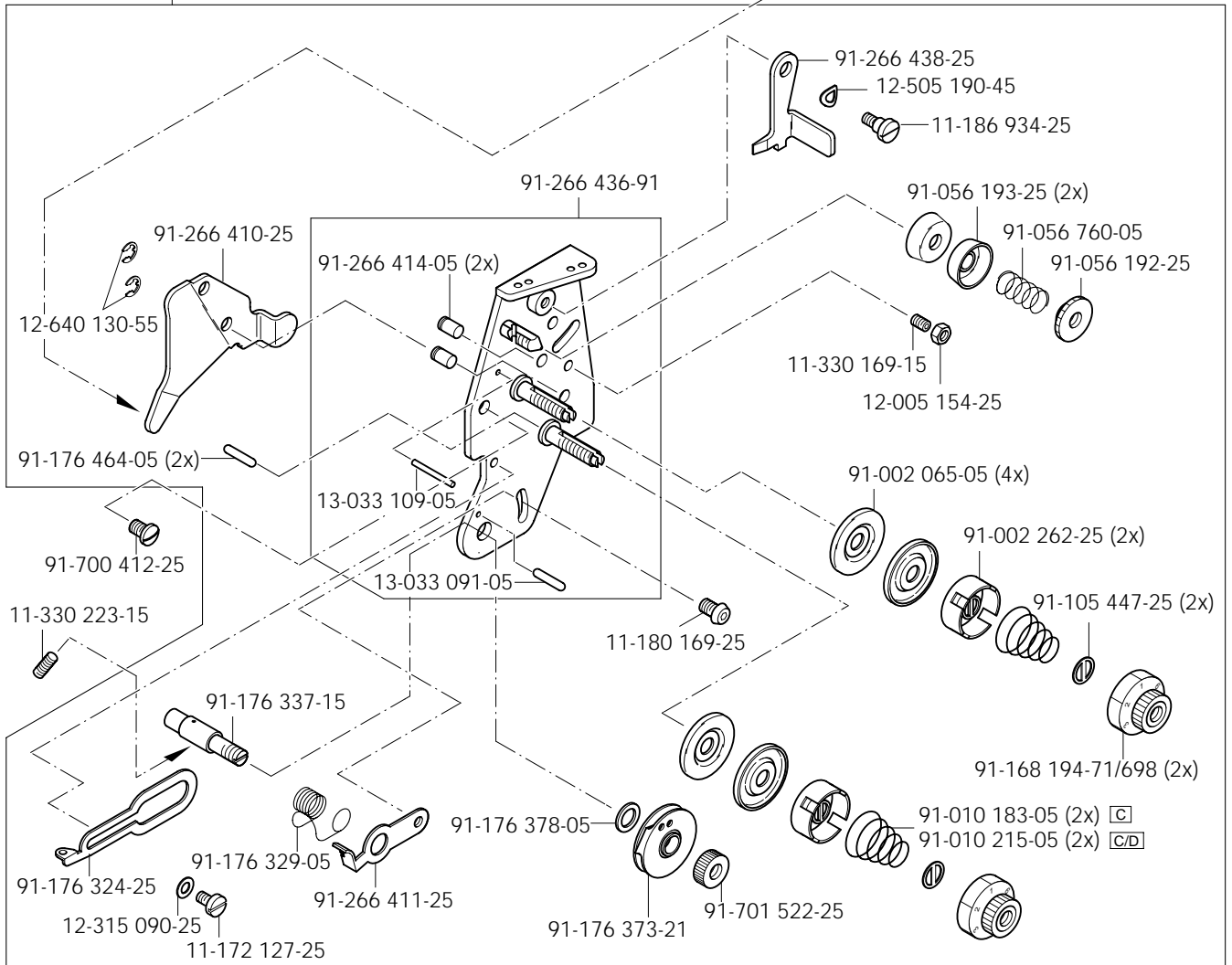
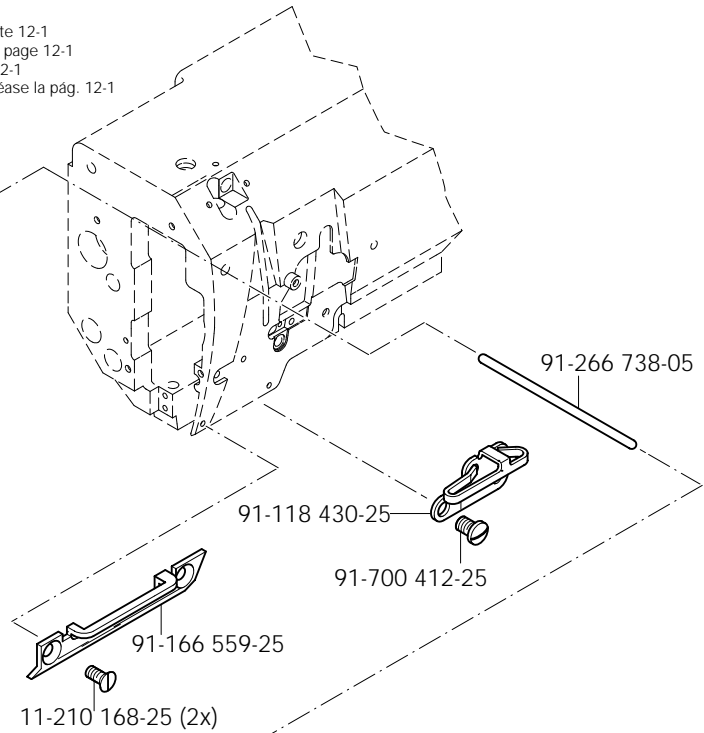

# 3.02

Kopfteile  
Needle head parts  
Pièces de tête  
Piezas de la cabeza

PFAFF 1526-900/81

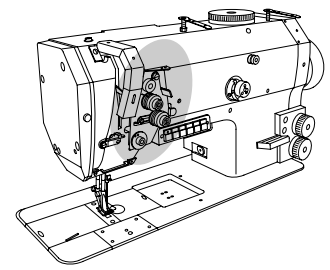

91-266 447-71/698   
91-266 463-71/698

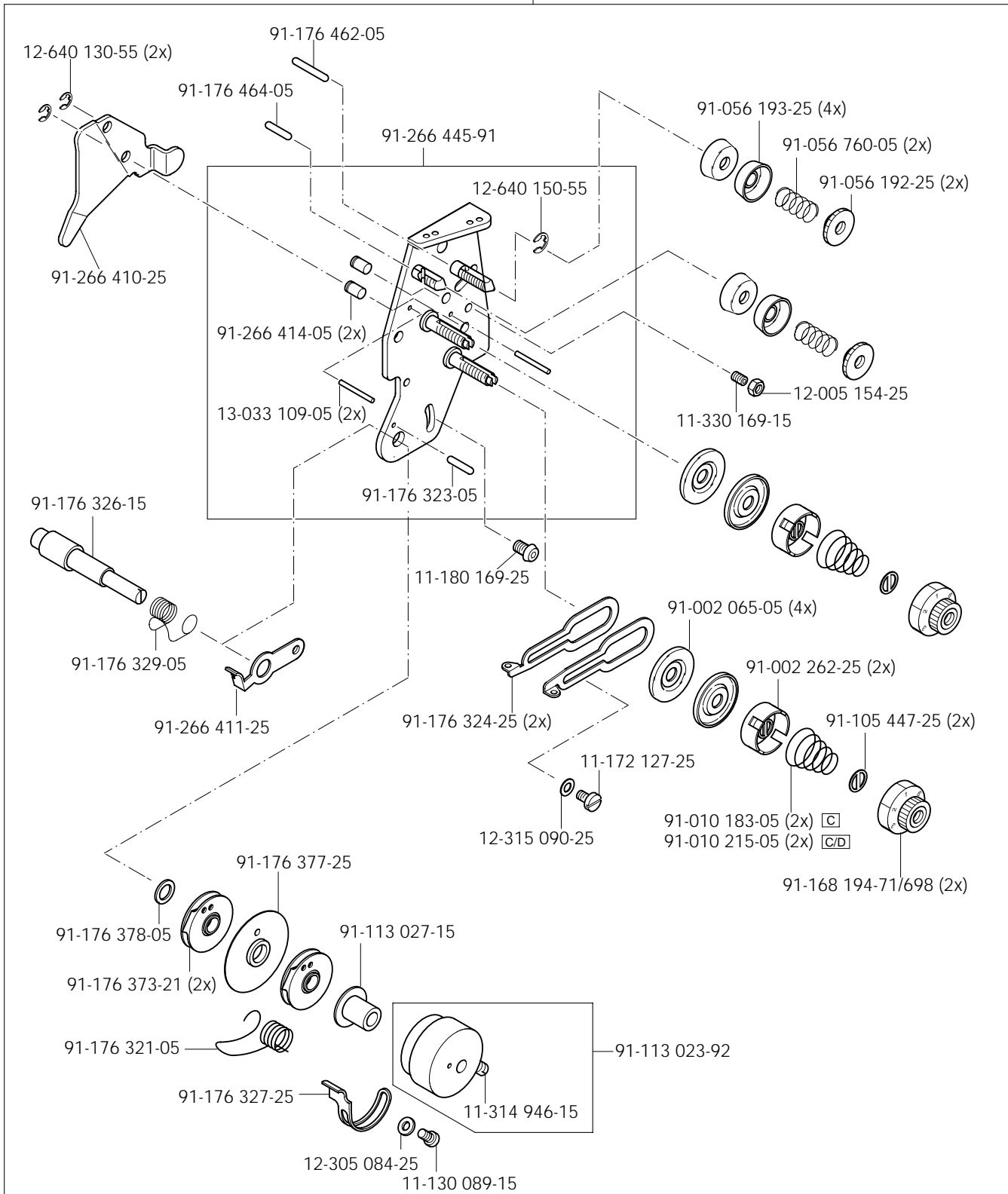

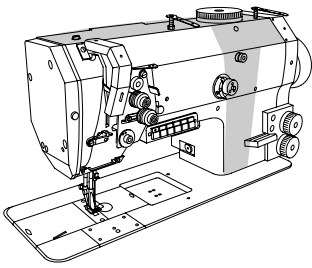

Armteile  
 Arm parts  
 Pièces de bras  
 Piezas del brazo

PFAFF 1525-900/81;-900/82  
 PFAFF 1526-900/81

3.03

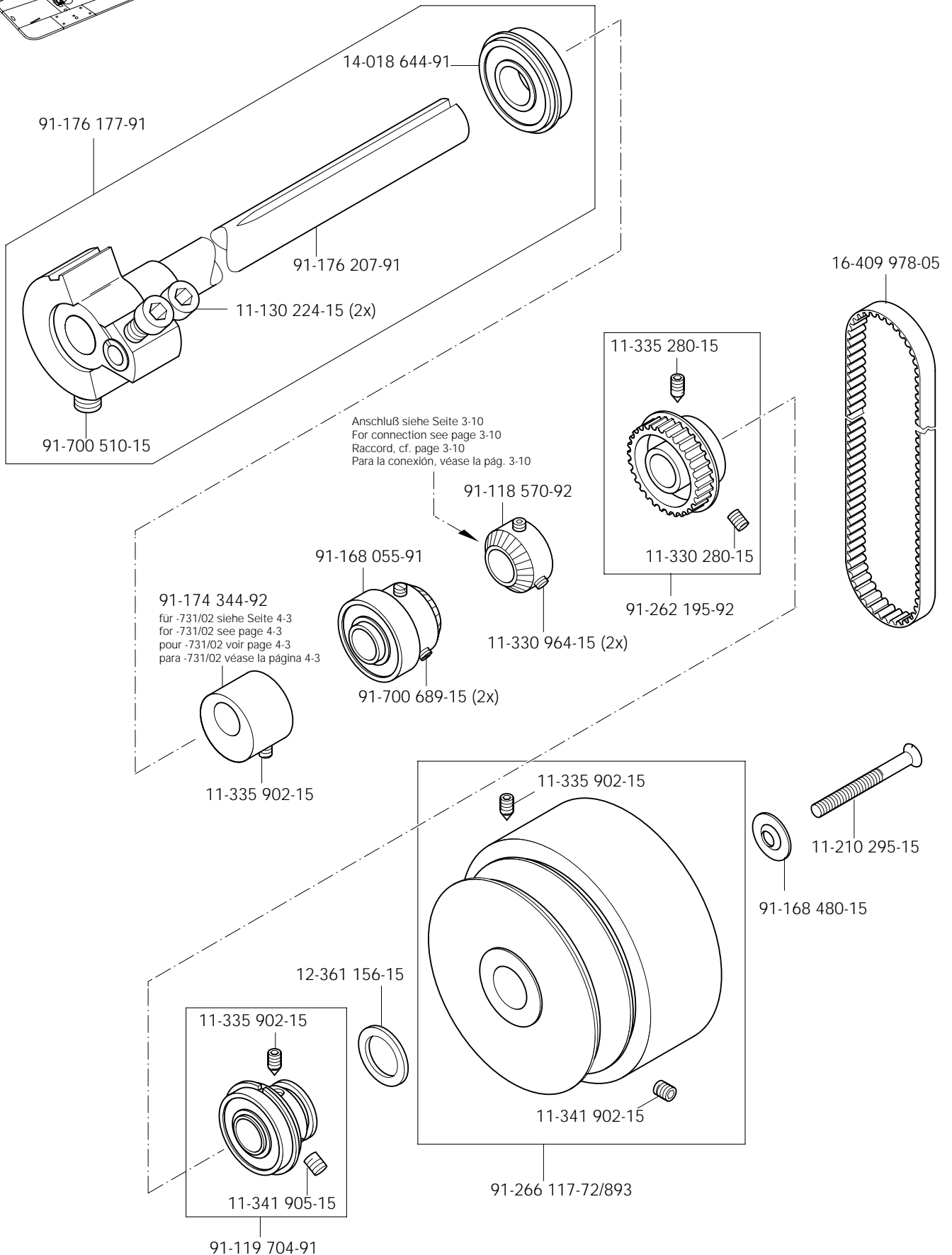

# 3.03

Armteile  
Arm parts

Pièces de bras PFAFF 1525-900/81;-900/82  
Piezas del brazo PFAFF 1526-900/81

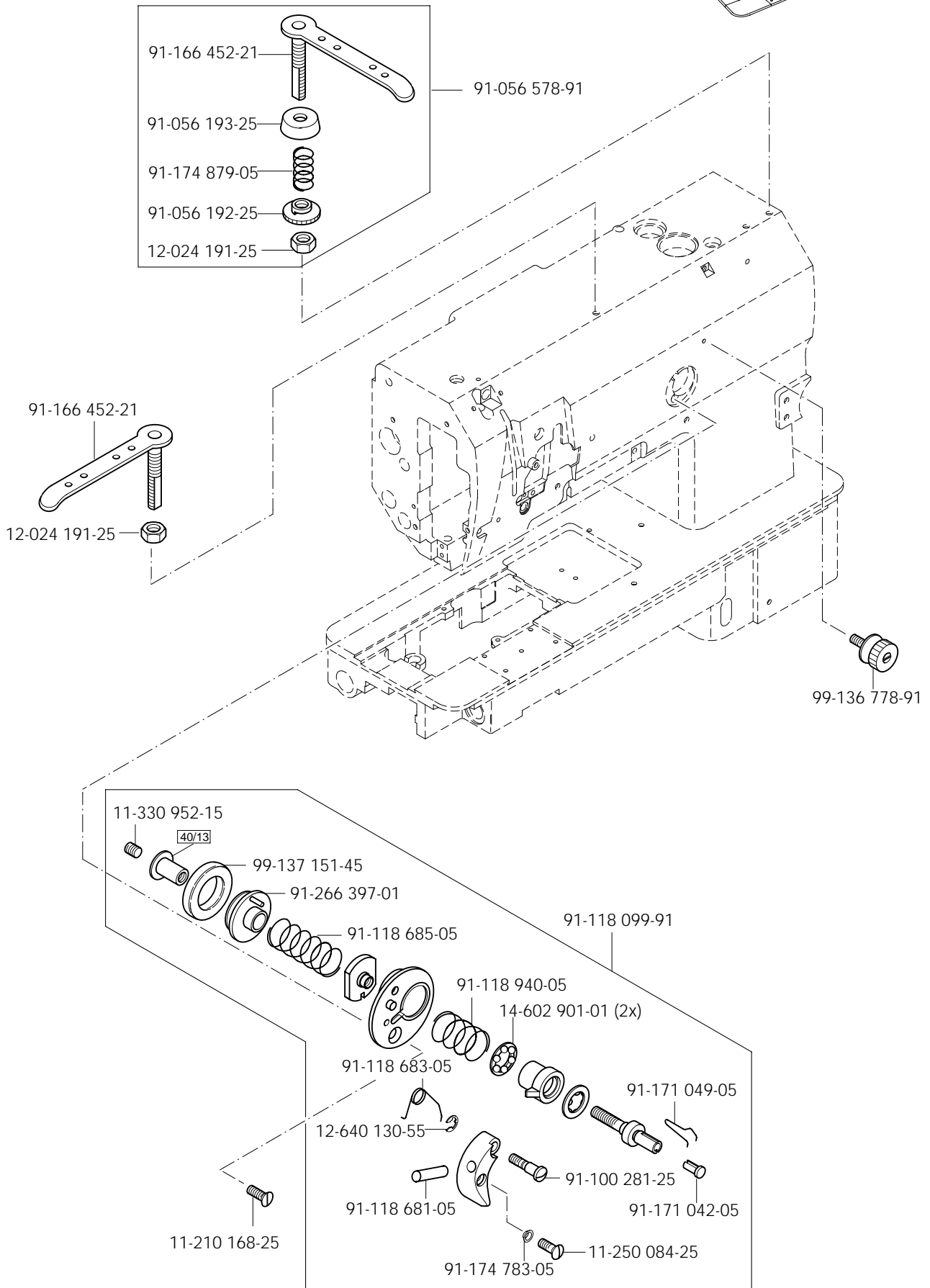
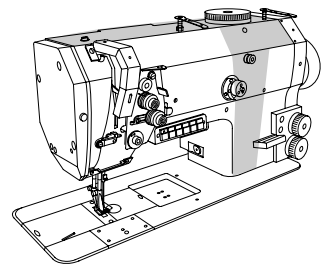

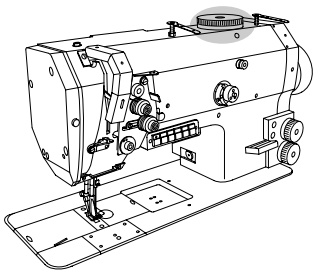

Armteile  
 Arm parts  
 Pièces de bras PFAFF 1525-900/81;-900/82  
 Piezas del brazo PFAFF 1526-900/81

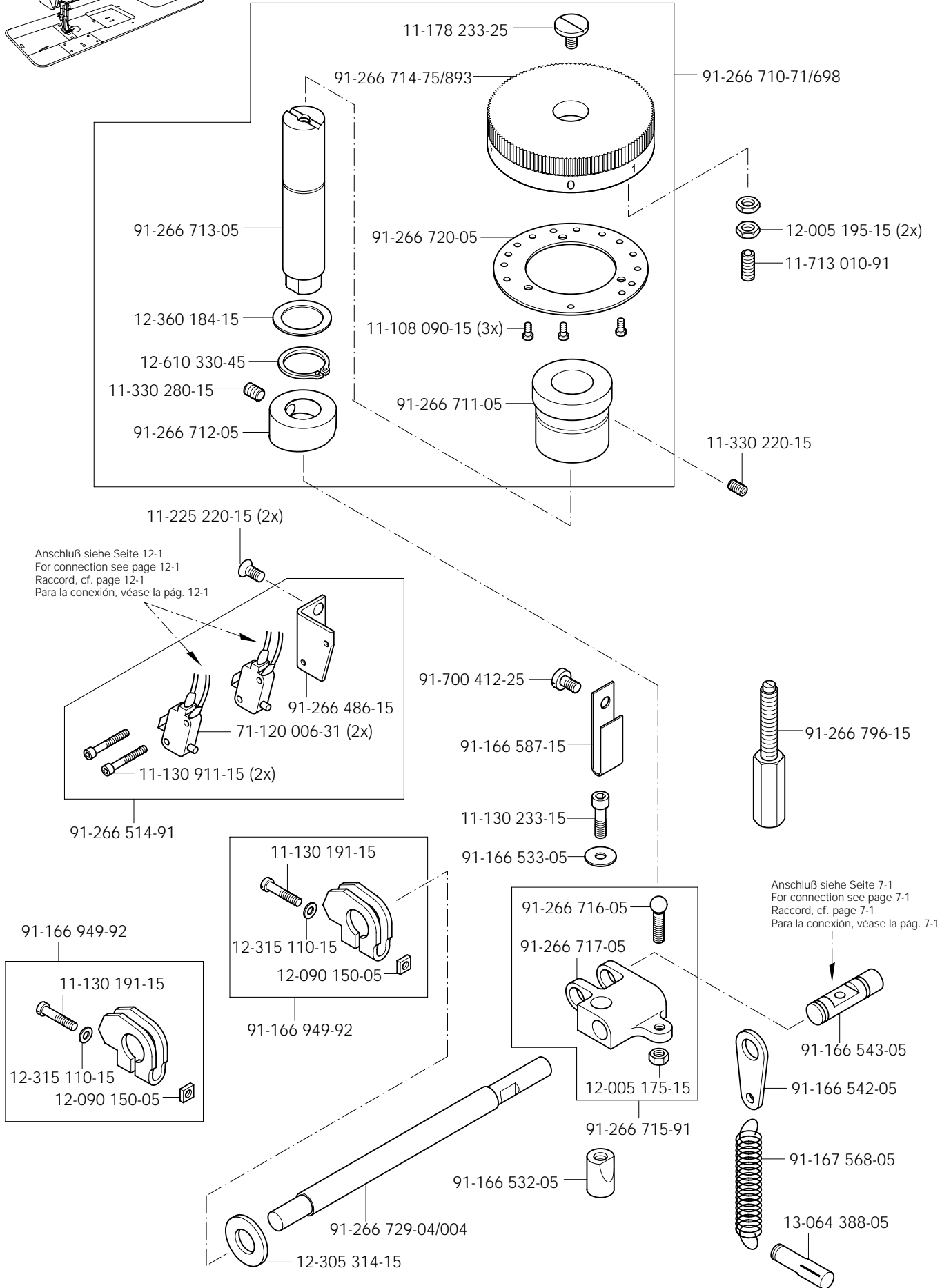

# 3.03

Armteile

Arm parts

Pièces de bras

Piezas del brazo

PFAFF 1525-900/81;-900/82

PFAFF 1526-900/81

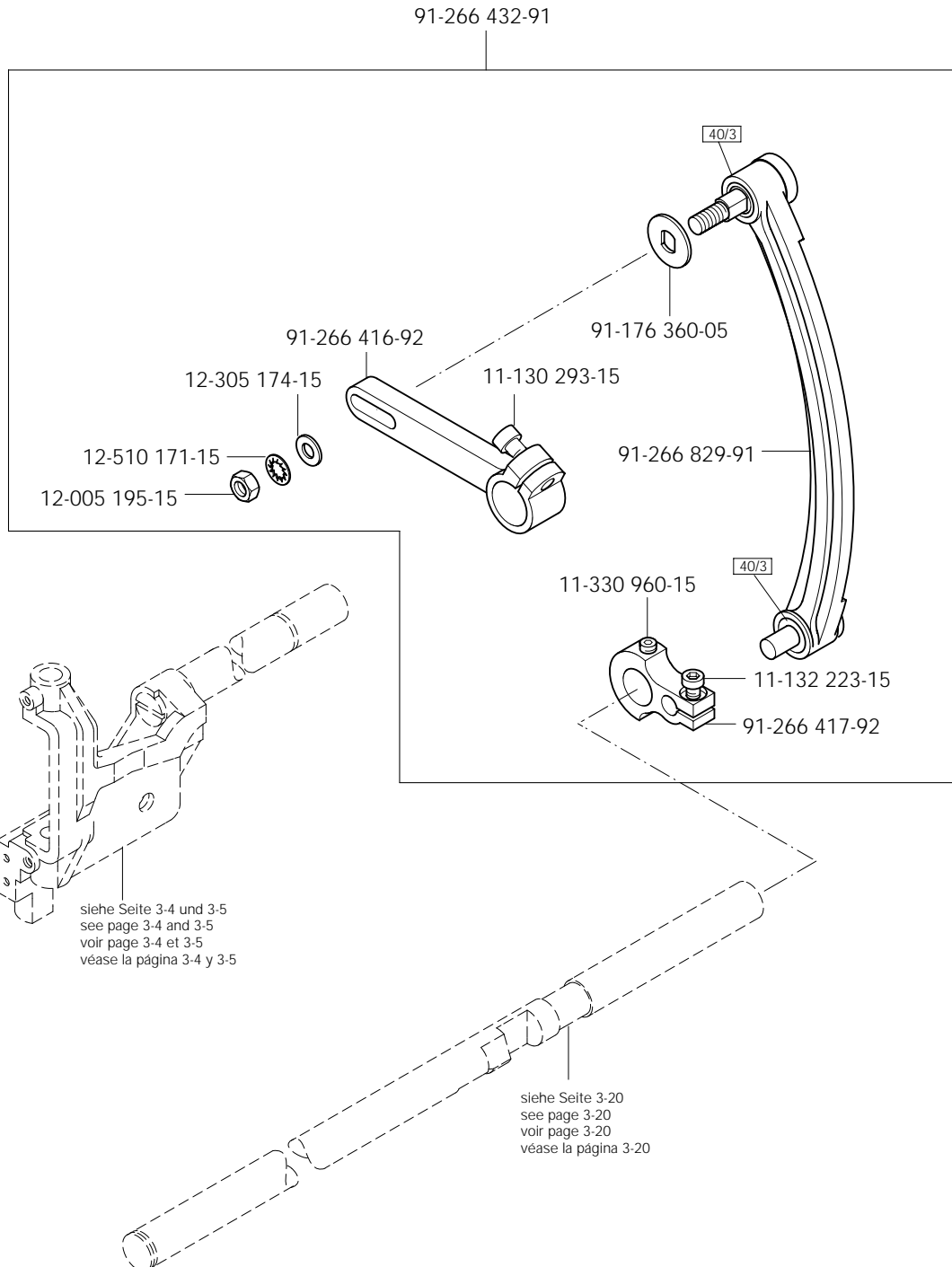
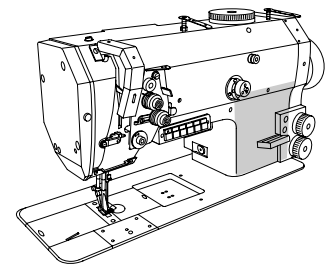



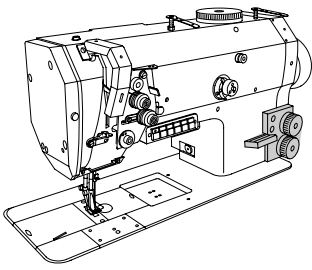

Armteile

Arm parts

Pièces de bras

PFAFF 1525-900/81;-900/82

Piezas del brazo

PFAFF 1526-900/81

3.03

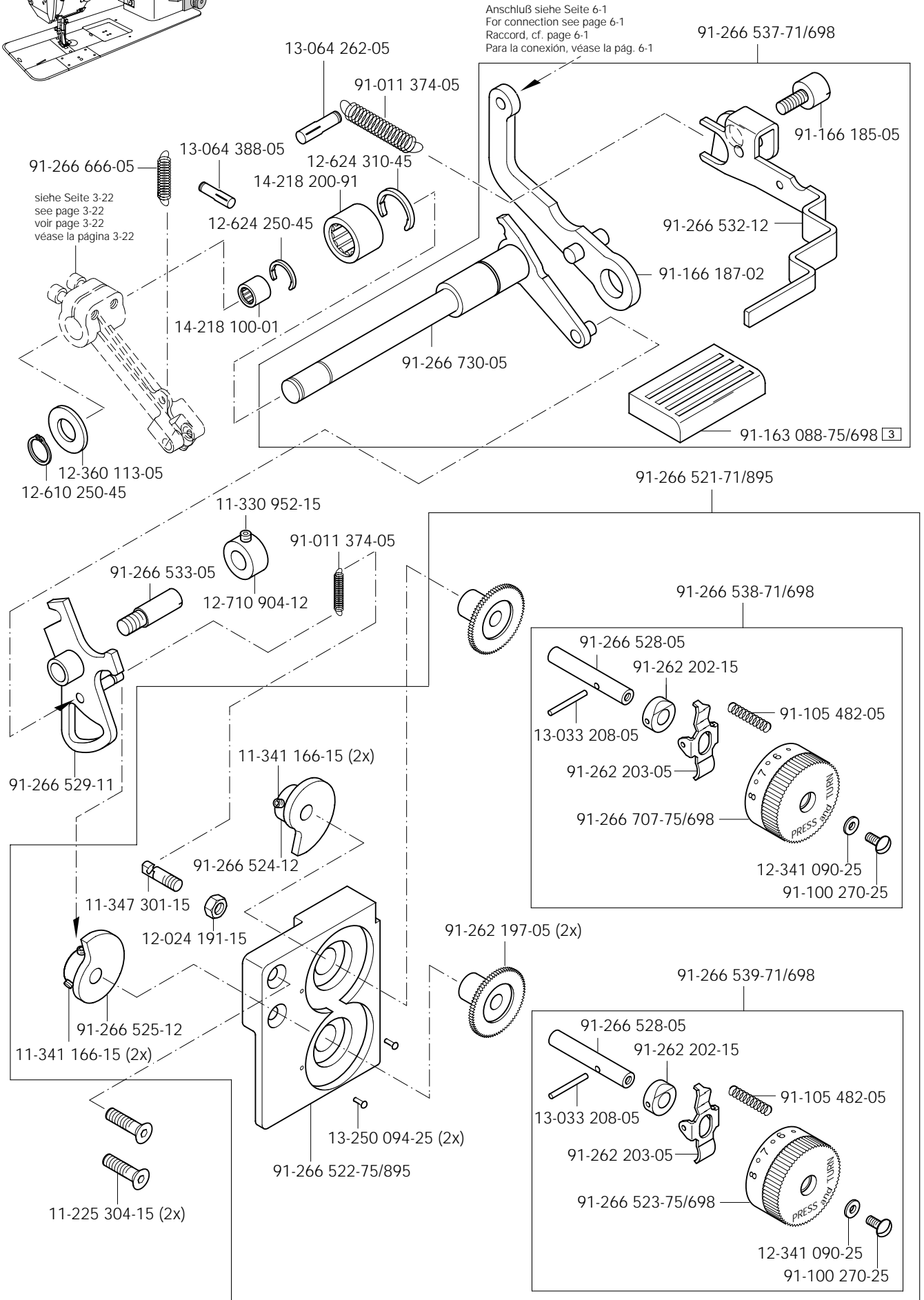

# 3.04

Grundplattenteile  
Bedplate parts  
Pièces du plateau fondamental  
Piezas del cárter

PFAFF 1525-900/81;-900/82  
PFAFF 1526-900/81

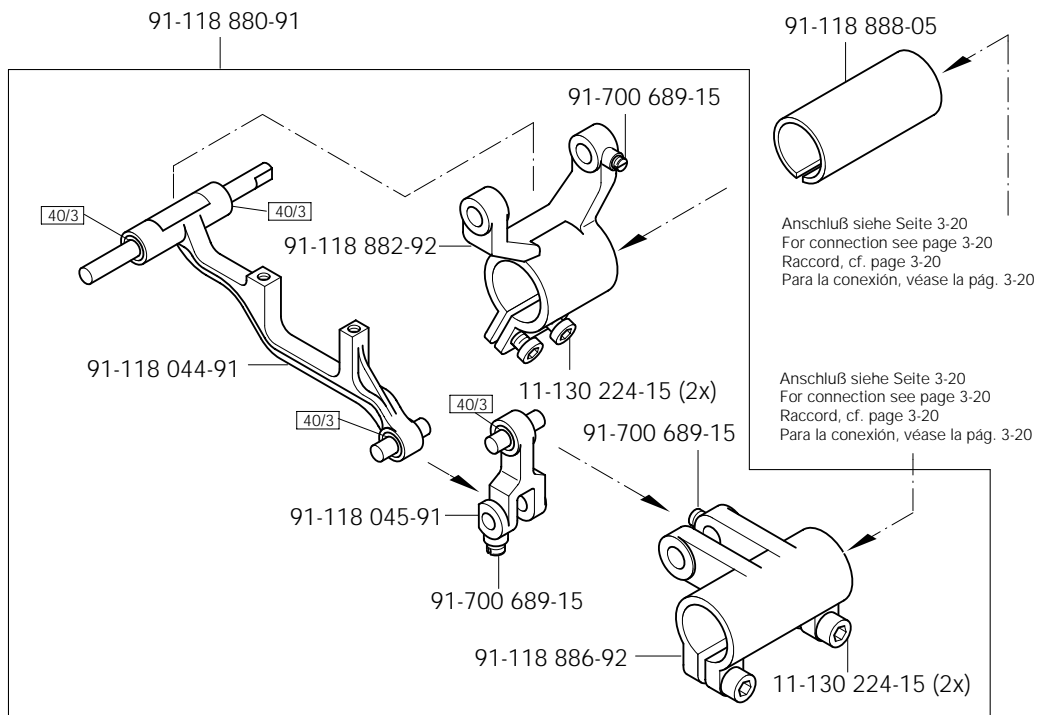
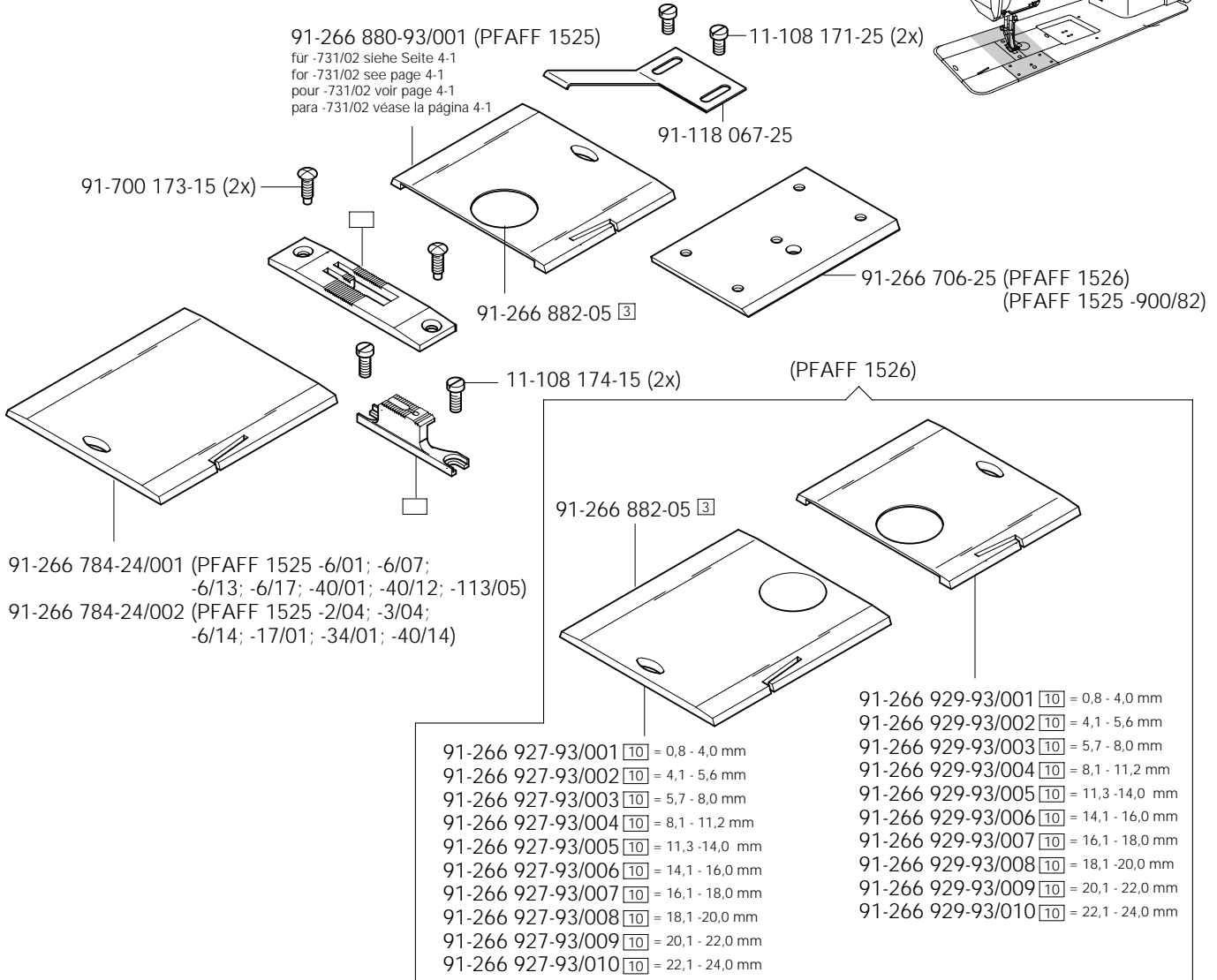
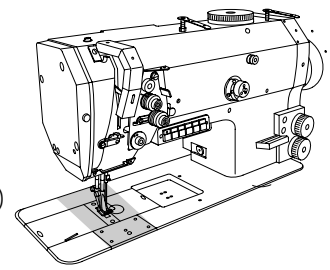

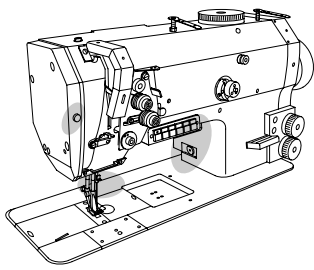

Grundplattenteile  
 Bedplate parts  
 Pièces du plateau fondamental  
 Piezas del cárter

PFAFF 1525-900/81;-900/82  
 PFAFF 1526-900/81

3.04

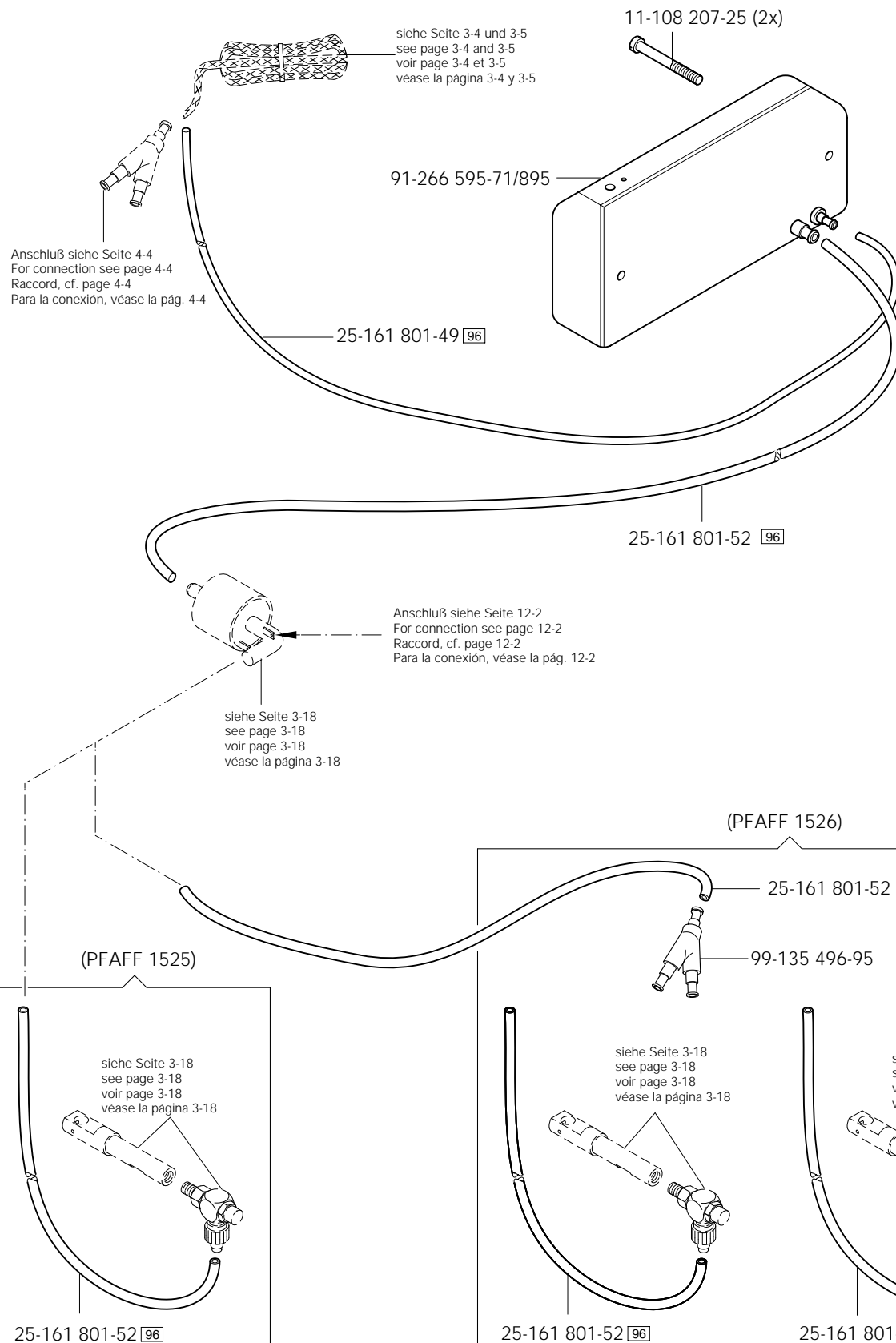

# 3.04

## Grundplattenteile Bedplate parts Pièces du plateau fondamental Piezas del cárter

PFAFF 1525-900/81;-900/82  
PFAFF 1526-900/81

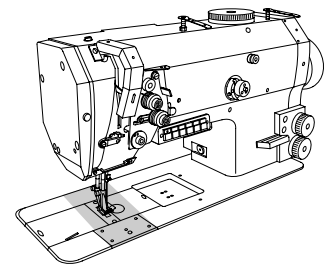

91-266 504-91  
für -901/01 siehe Seite 5-1  
for -901/01 see page 5-1  
pour -901/01 voir page 5-1  
para -901/01 véase la página 5-1

91-266 906-05  
für -926/06 siehe Seite 10-2  
for -926/06 see page 10-2  
pour -926/06 voir page 10-2  
para -926/06 véase la página 10-2

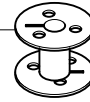

91-266 685-91 [28/1]

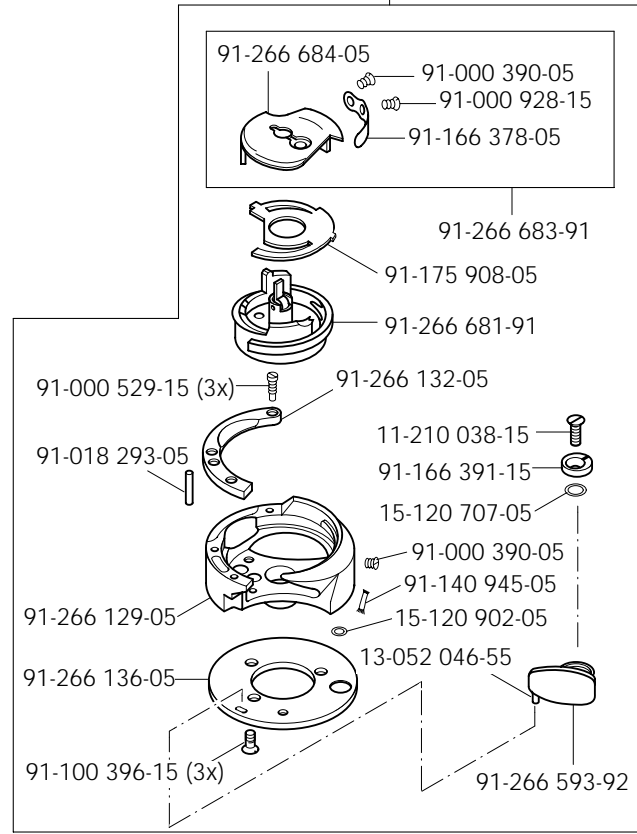
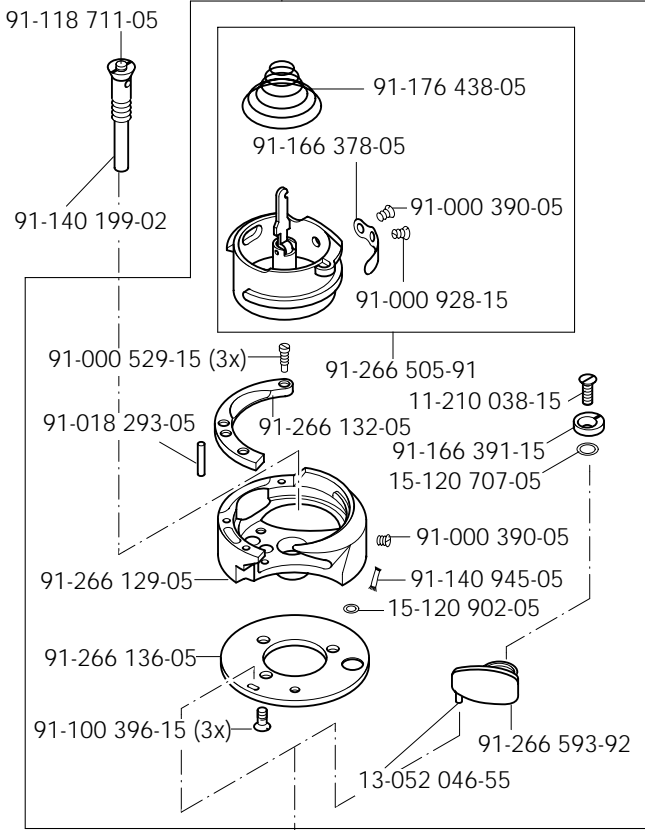

für -901/01 siehe Seite 5-1  
for -901/01 see page 5-1  
pour -901/01 voir page 5-1  
para -901/01 véase la página 5-1

91-166 388-05  
91-166 827-05 (0,1) [27/2]  
91-166 828-05 (0,2) [27/2]

91-166 376-91 (PFAFF 1526)  
(PFAFF 1525 -731/02)

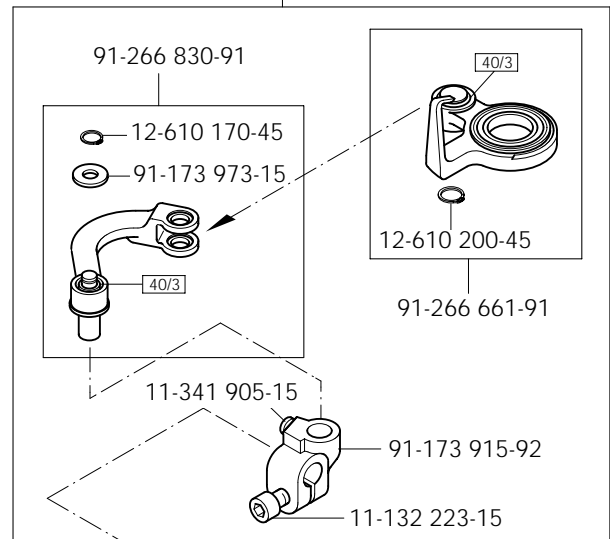
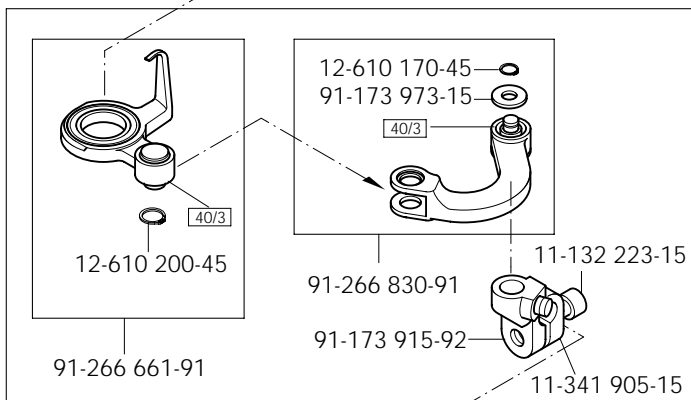

siehe Seite 3-17  
see page 3-17  
voir page 3-17  
véase la página 3-17

91-166 376-91  
für -901/01 siehe Seite 5-1  
for -901/01 see page 5-1  
pour -901/01 voir page 5-1  
para -901/01 véase la página 5-1

siehe Seite 3-18  
see page 3-18  
voir page 3-18  
véase la página 3-18

siehe Seite 3-18  
see page 3-18  
voir page 3-18  
véase la página 3-18

siehe Seite 3-17  
see page 3-17  
voir page 3-17  
véase la página 3-17

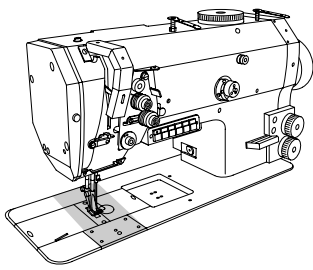

Grundplattenteile  
Bedplate parts  
Pièces du plateau fondamental  
Piezas del cárter

PFAFF 1525-900/81;-900/82  
PFAFF 1526-900/81

3.04

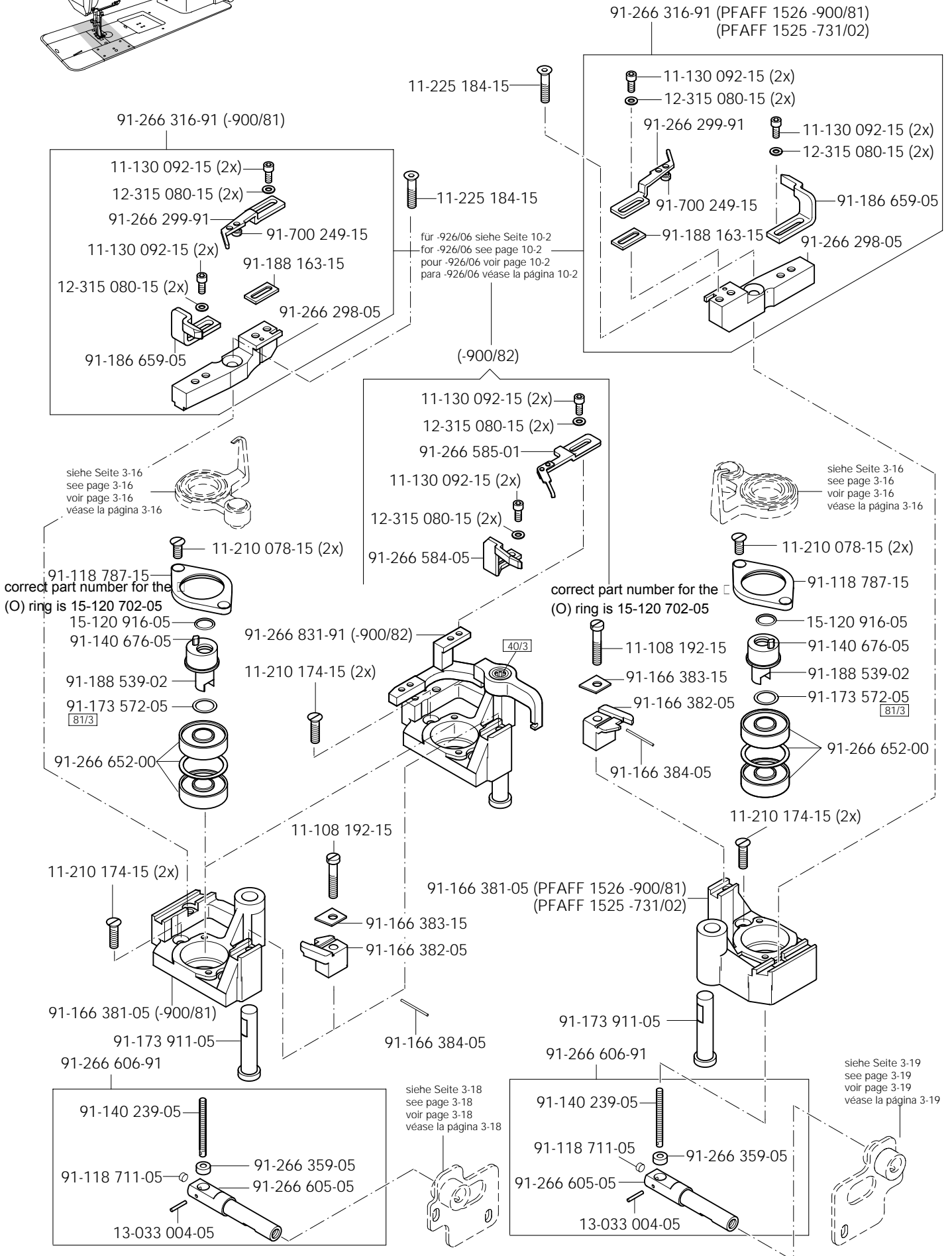

# 3.04

## Grundplattenteile Bedplate parts Pièces du plateau fondamental Piezas del cárter

PFAFF 1525-900/81;-900/82  
PFAFF 1526-900/81

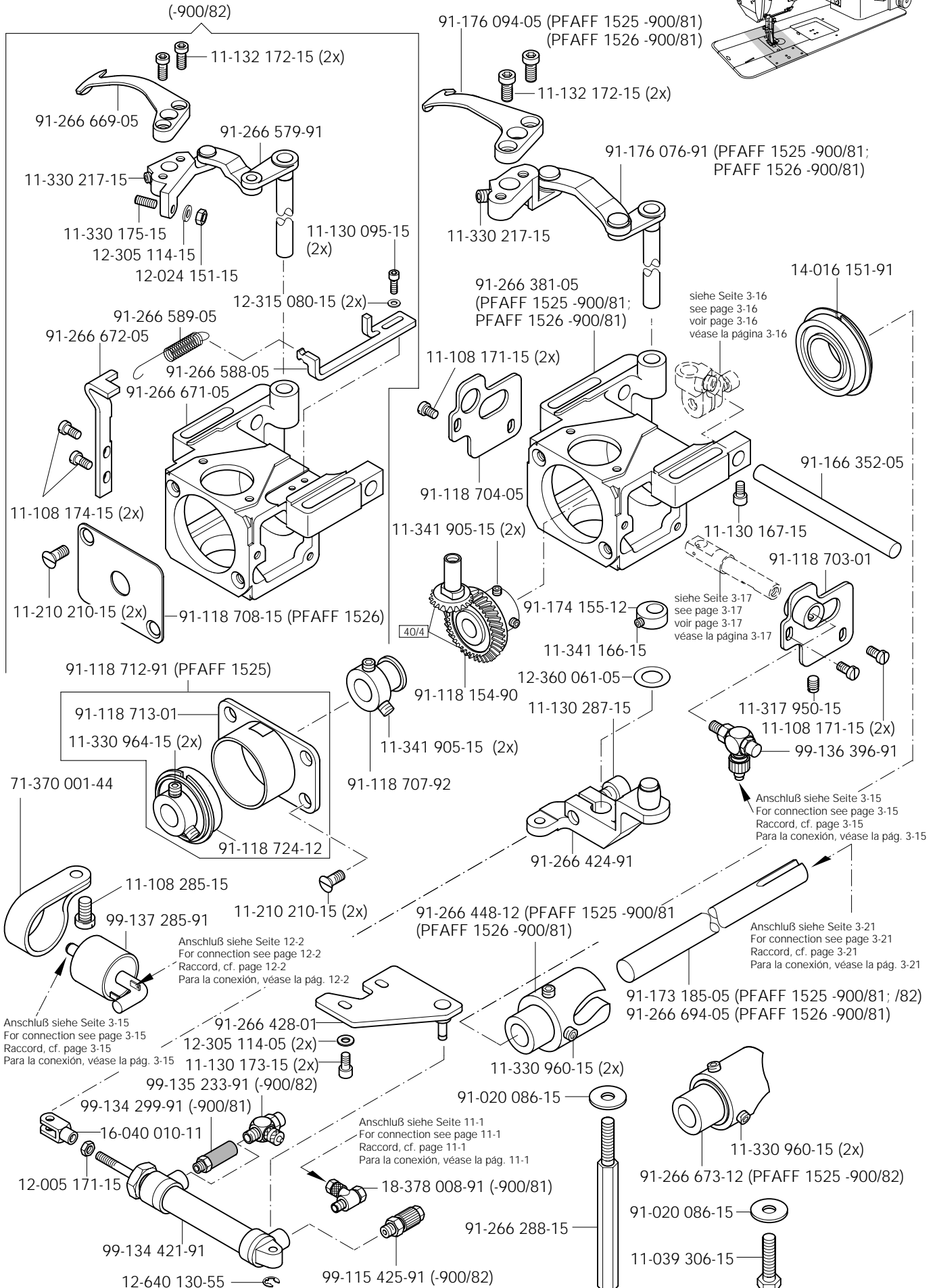
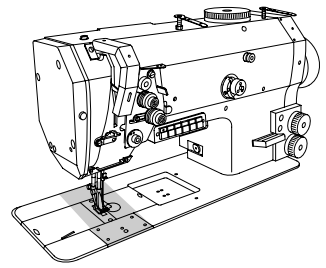

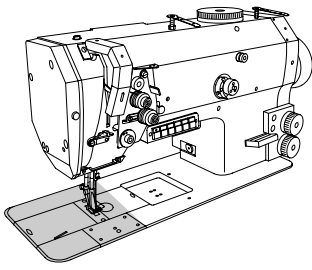

Grundplattenteile  
 Bedplate parts  
 Pièces du plateau fondamental  
 Piezas del cárter

PFAFF 1526-900/81

3.04

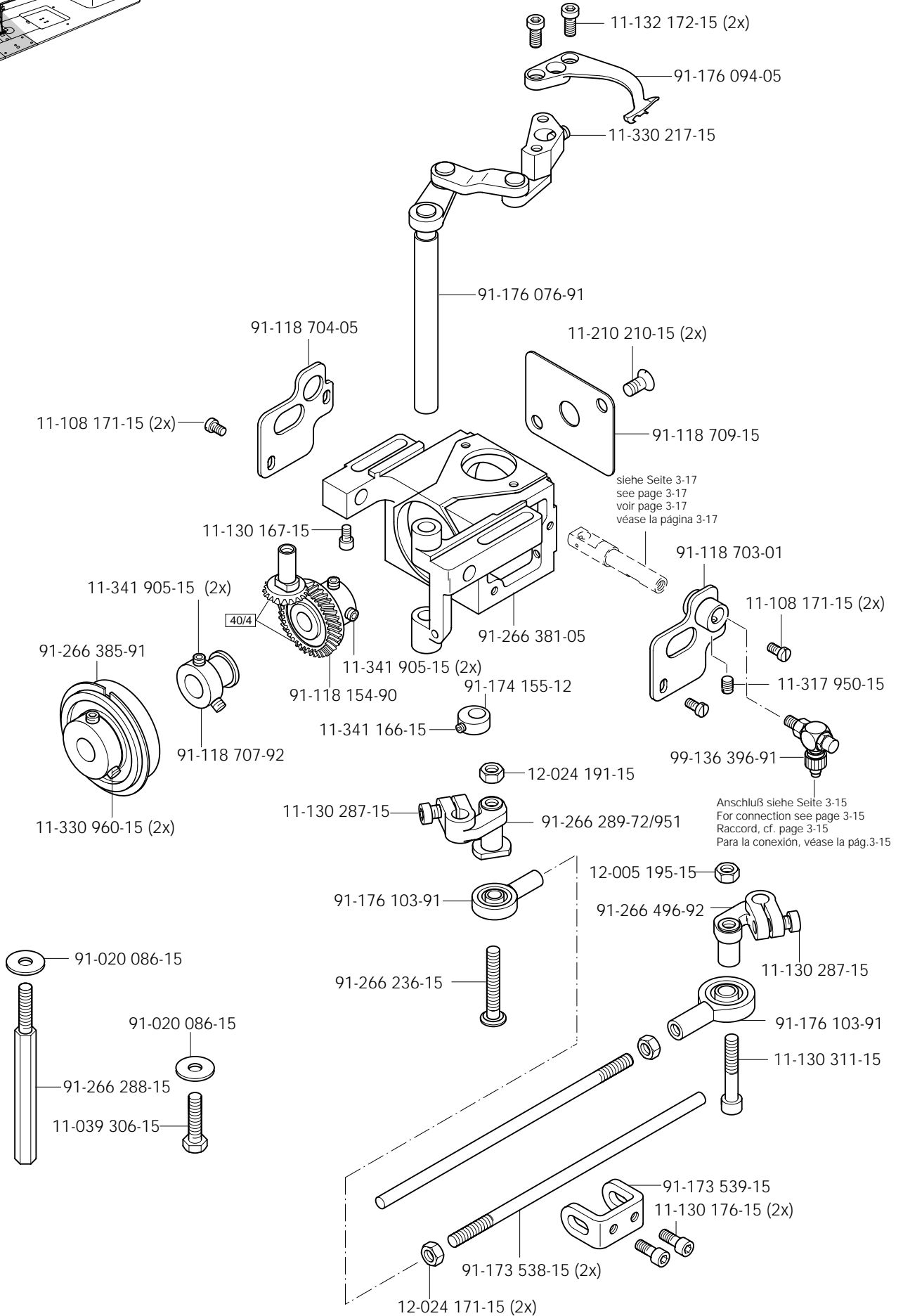

# 3.04

Grundplattenteile  
 Bedplate parts  
 Pièces du plateau fondamental  
 Piezas del cárter

PFAFF 1525-900/81;-900/82  
 PFAFF 1526-900/81

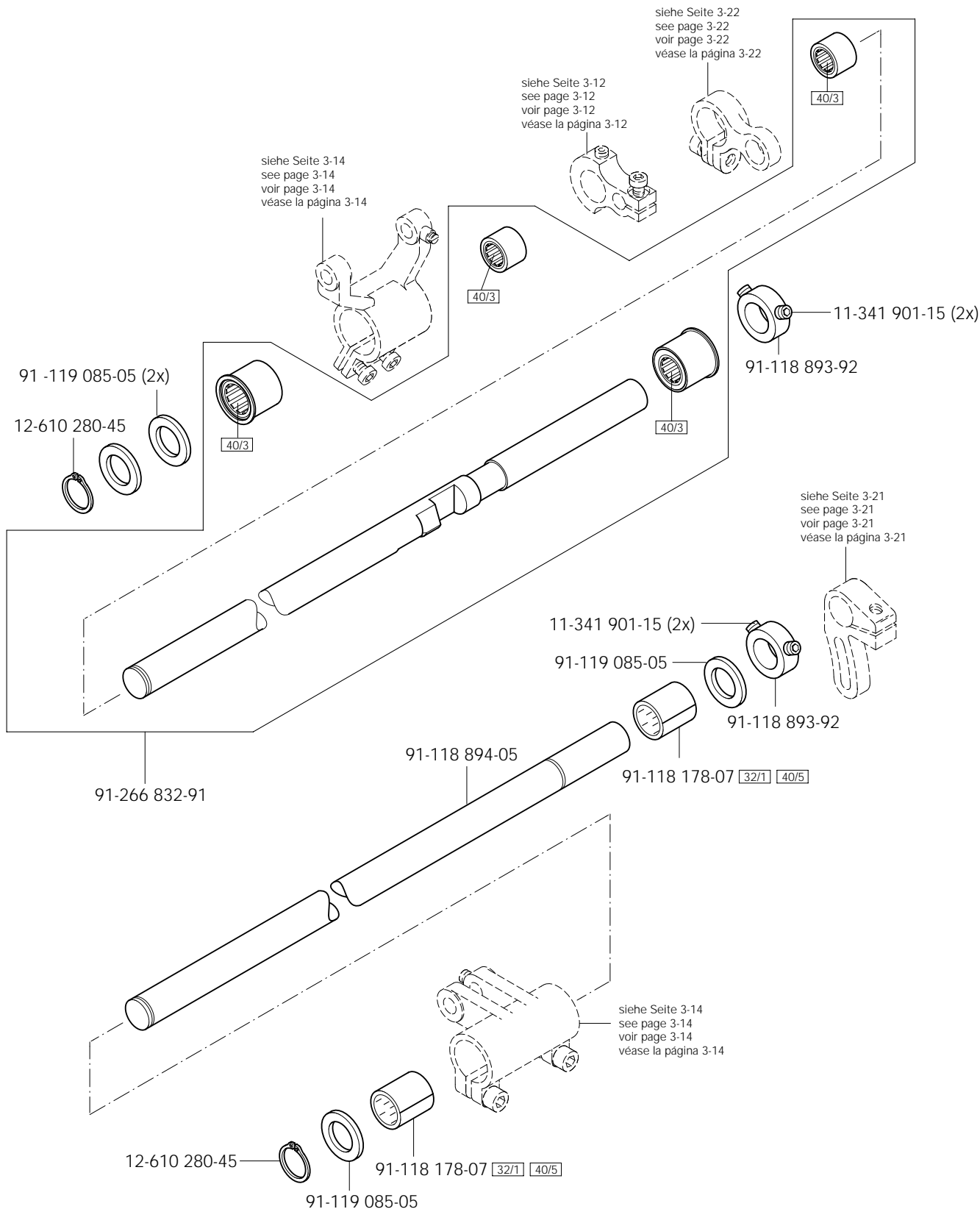
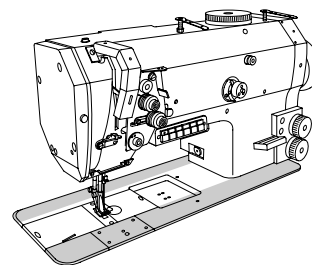



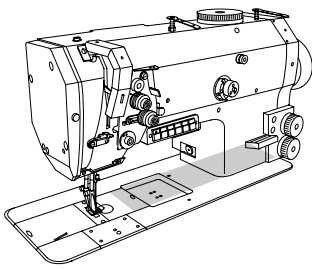

Grundplattenteile  
 Bedplate parts  
 Pièces du plateau fondamental  
 Piezas del cárter

PFAFF 1525-900/81;-900/82  
 PFAFF 1526-900/81

3.04

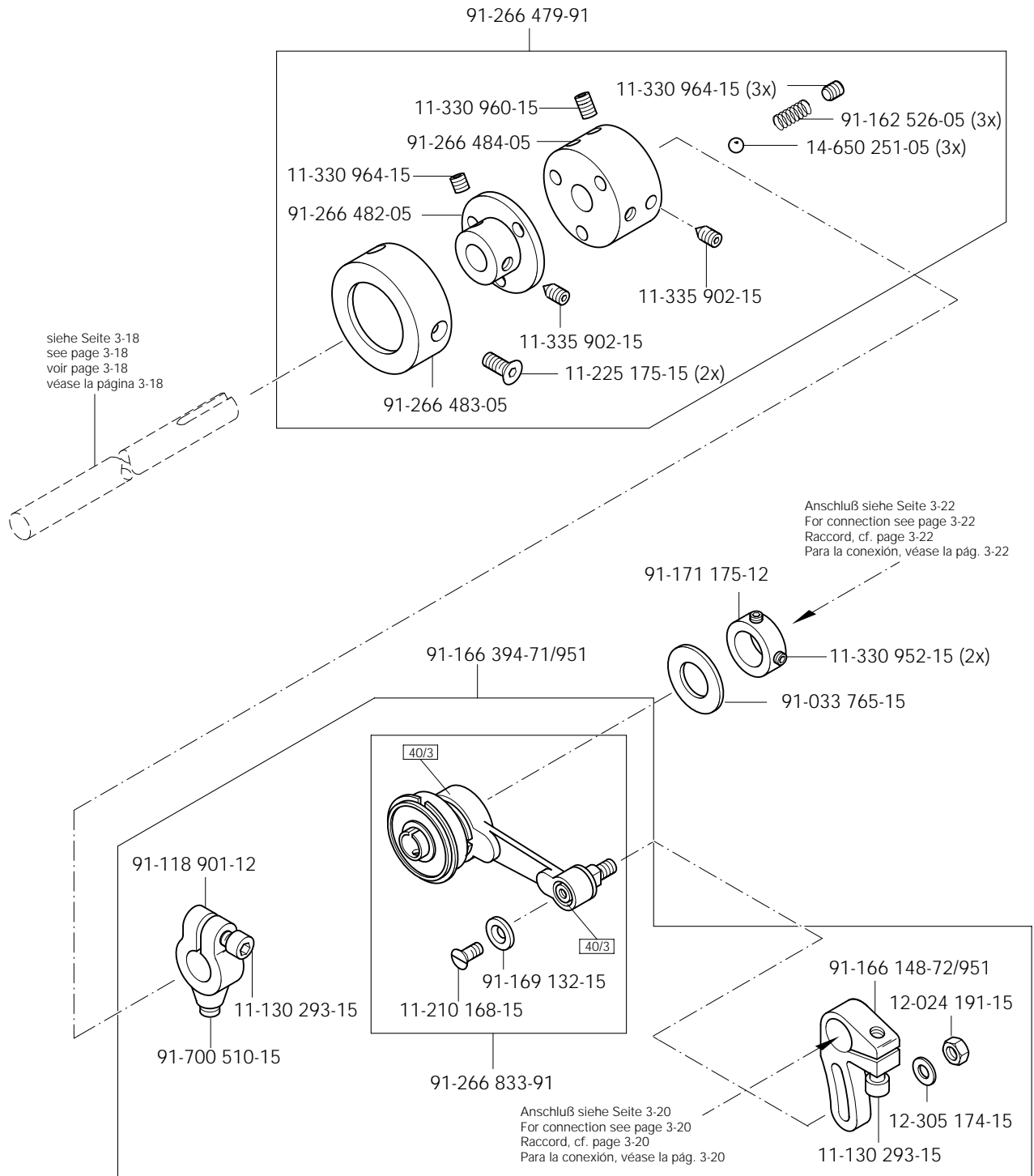

# 3.04

## Grundplattenteile Bedplate parts Pièces du plateau fondamental Piezas del cárter

PFAFF 1525-900/81;-900/82  
PFAFF 1526-900/81

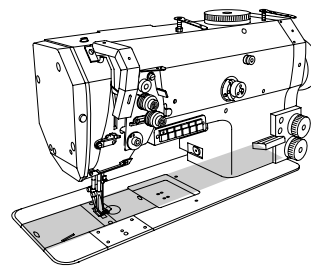

siehe Seite 3-20  
see page 3-20  
voir page 3-20  
véase la página 3-20

siehe Seite 3-13  
see page 3-13  
voir page 3-13  
véase la página 3-13

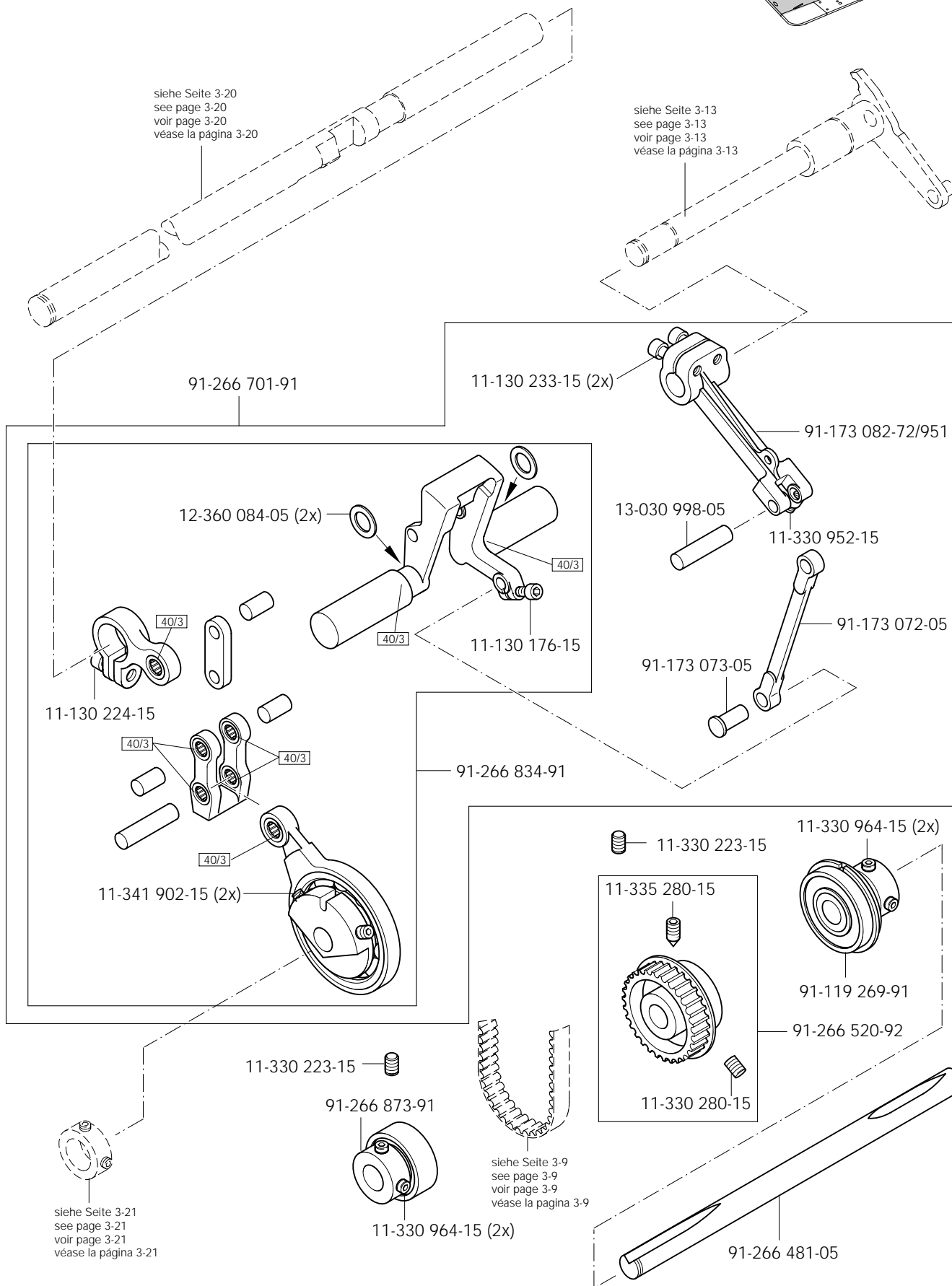

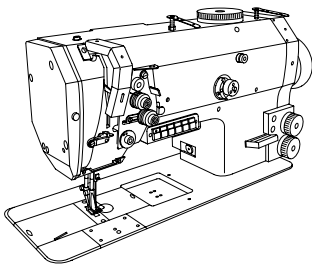

Kanten-Beschneideinrichtung (-731/02)

Edge trimmer (-731/02)

Couteau (-731/02)

Recortador (-731/02)

PFAFF 1525-900/81

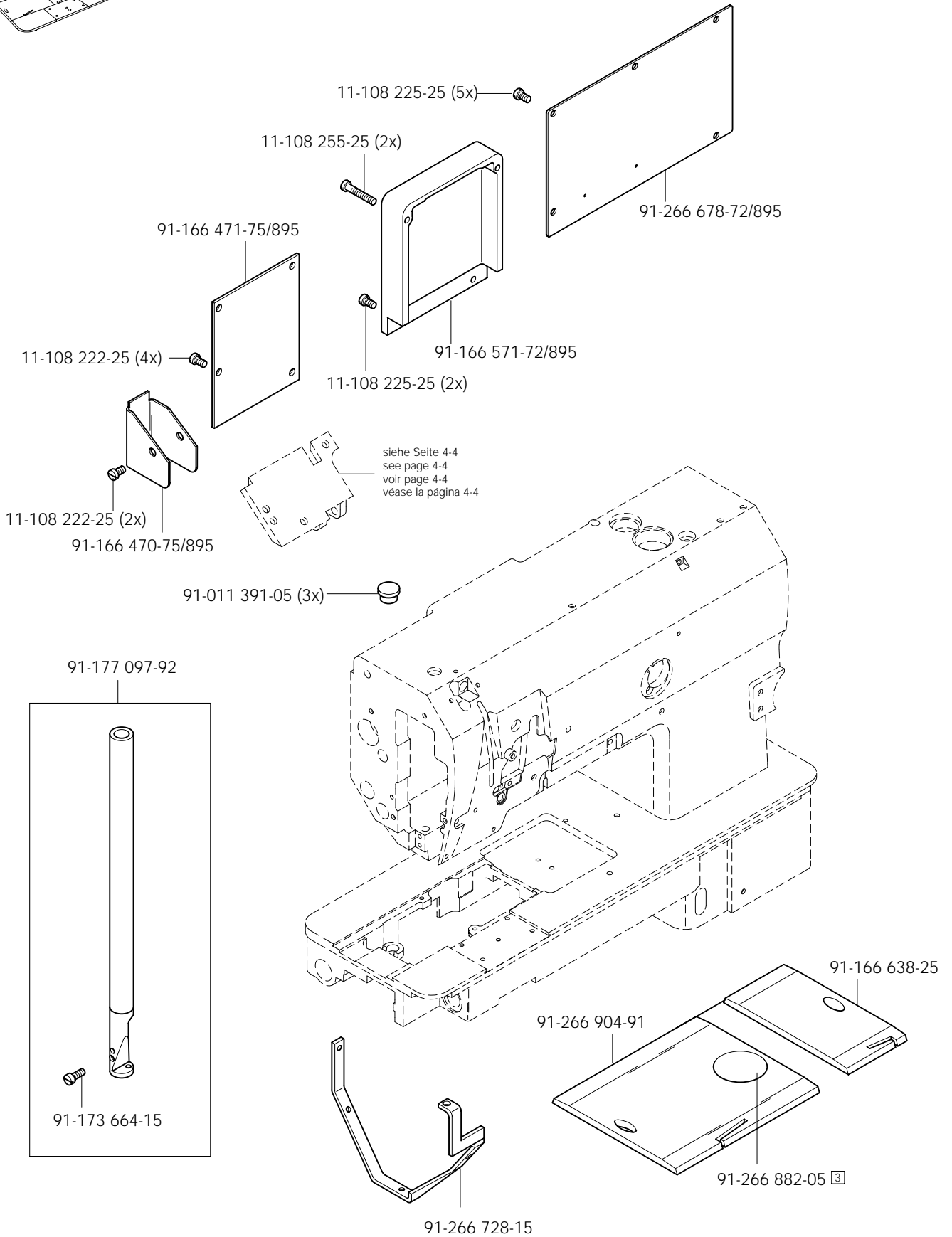

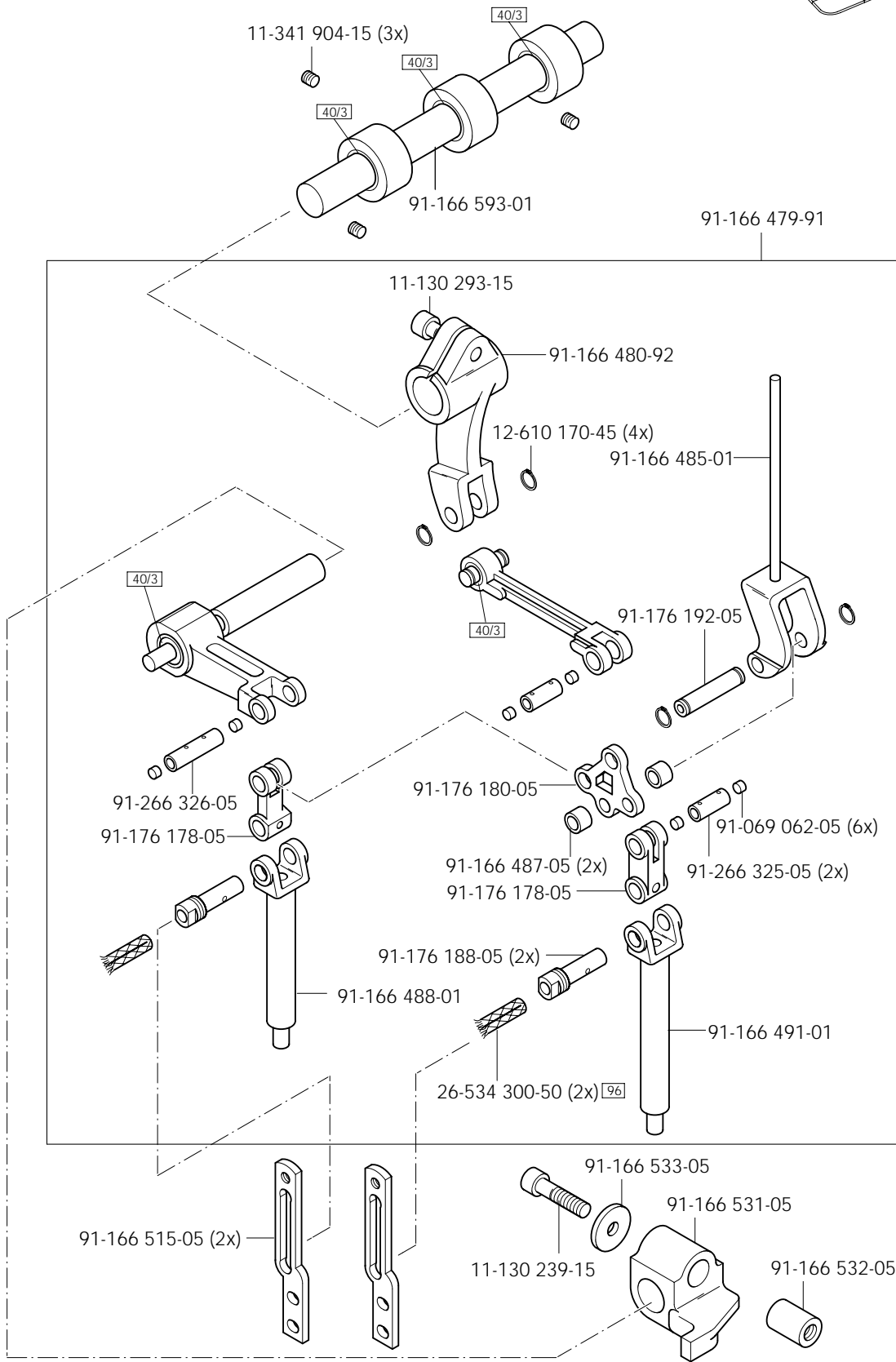
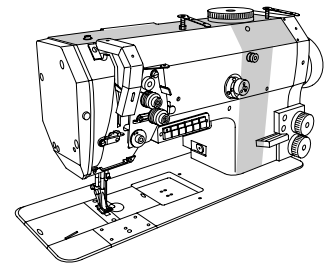

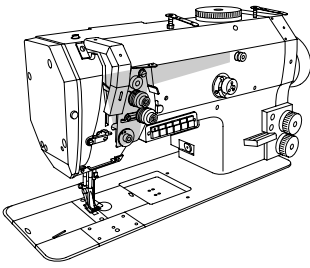

Kanten-Beschneideinrichtung (-731/02)  
 Edge trimmer (-731/02)  
 Couteau (-731/02)  
 Recortador (-731/02)

PFAFF 1525-900/81

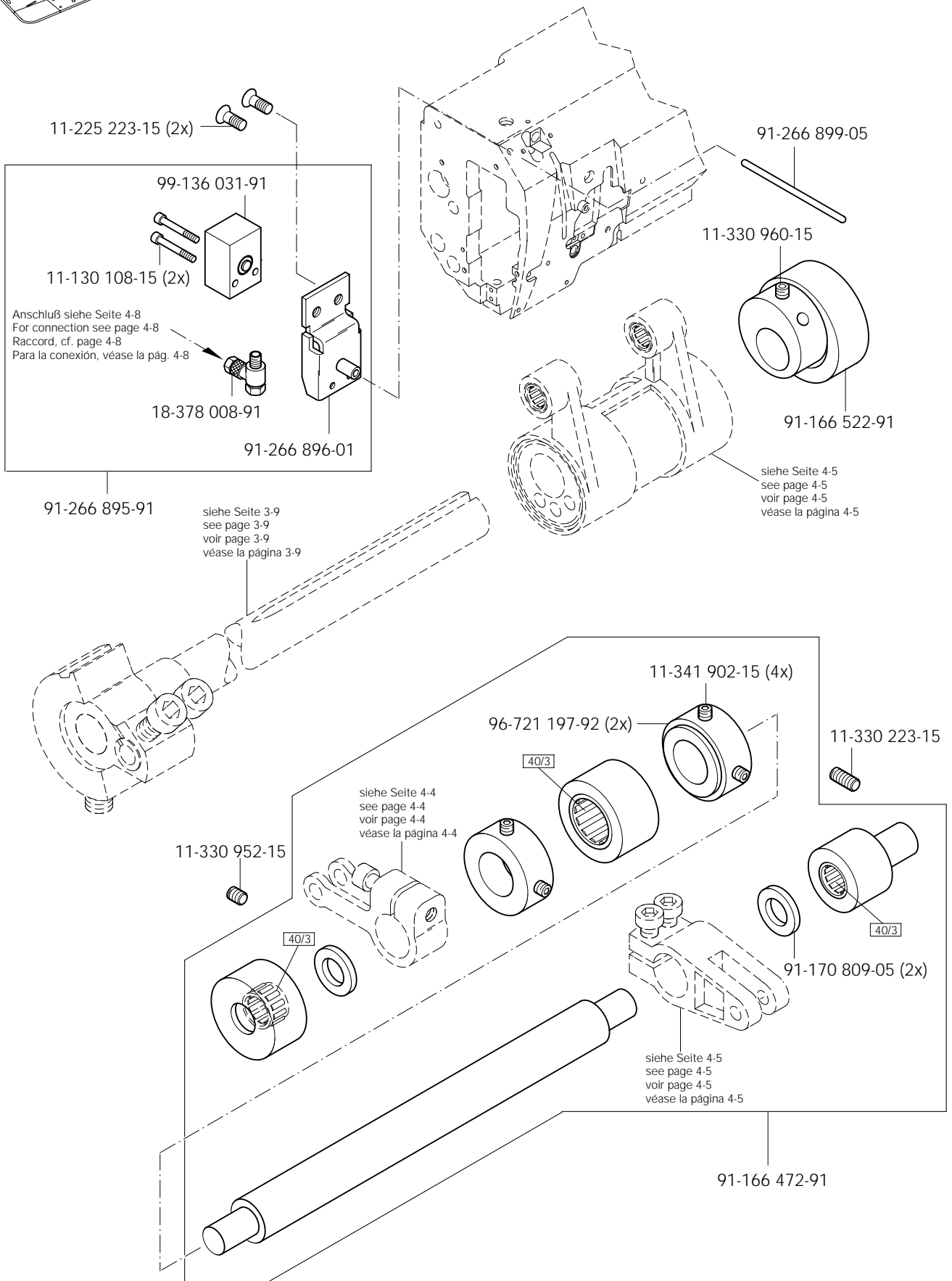

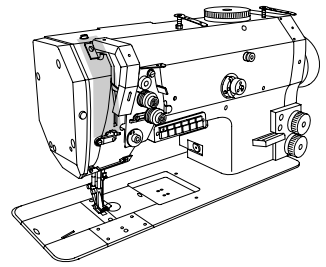

Anschluß siehe Seite 4-3  
 For connection see page 4-3  
 Raccord, cf. page 4-3  
 Para la conexión, véase la pág. 4-3

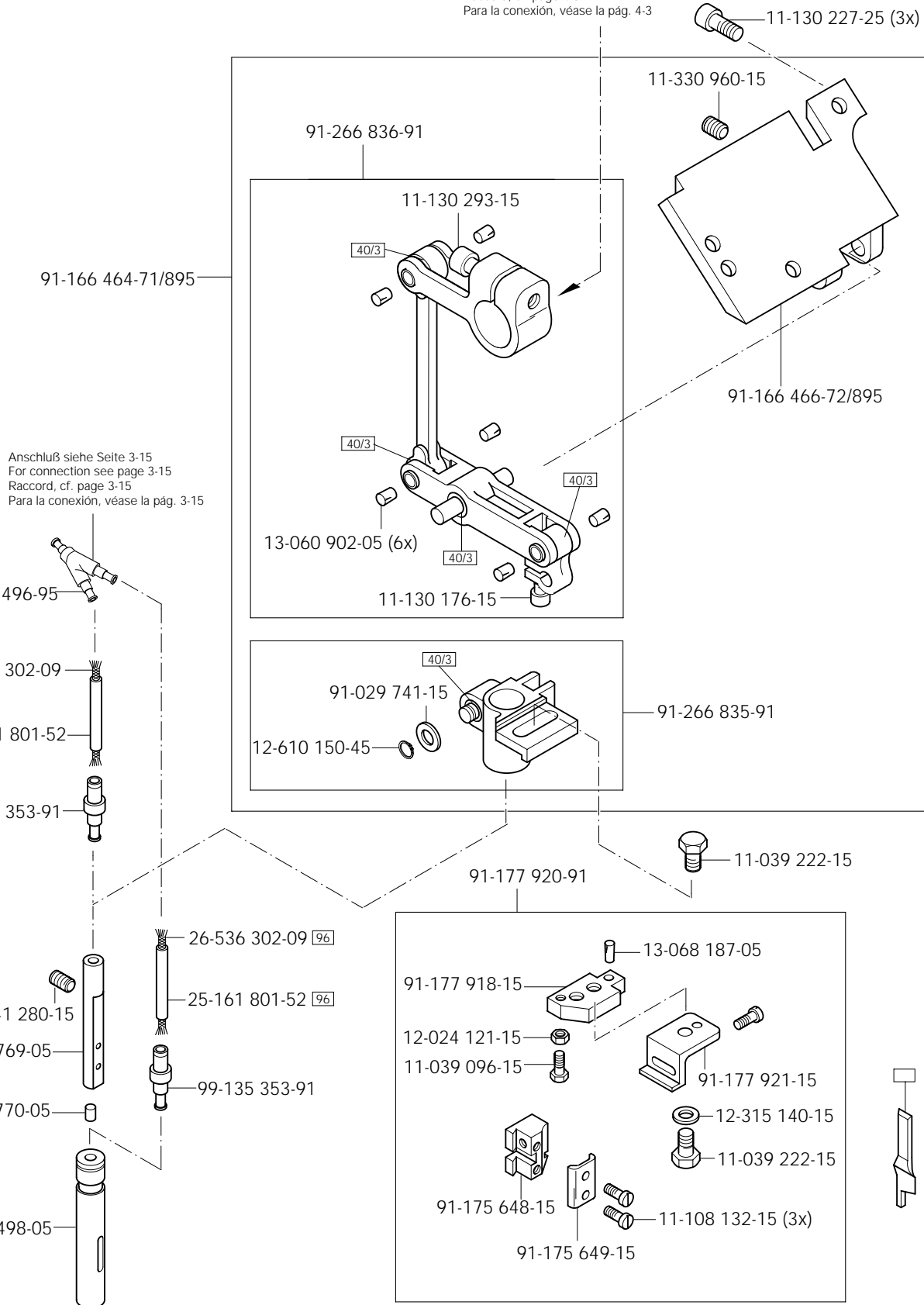

Anschluß siehe Seite 3-15  
 For connection see page 3-15  
 Raccord, cf. page 3-15  
 Para la conexión, véase la pág. 3-15

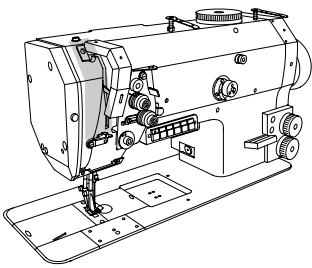

Kanten-Beschneideinrichtung (-731/02)  
 Edge trimmer (-731/02)  
 Couteau (-731/02)  
 Recortador (-731/02)

PFAFF 1525-900/81

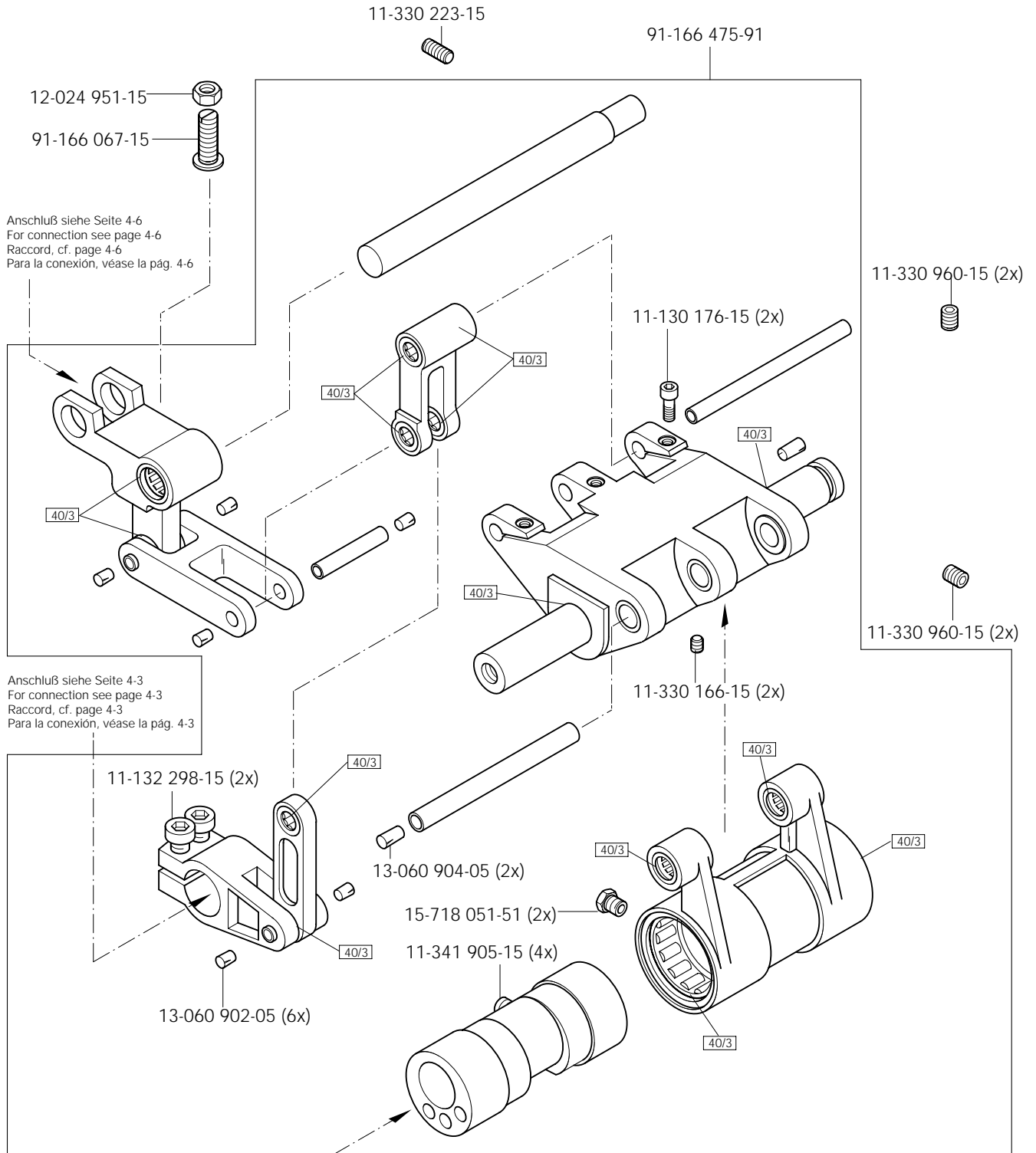

Anschluß siehe Seite 4-3  
 For connection see page 4-3  
 Raccord, cf. page 4-3  
 Para la conexión, véase la pág. 4-3

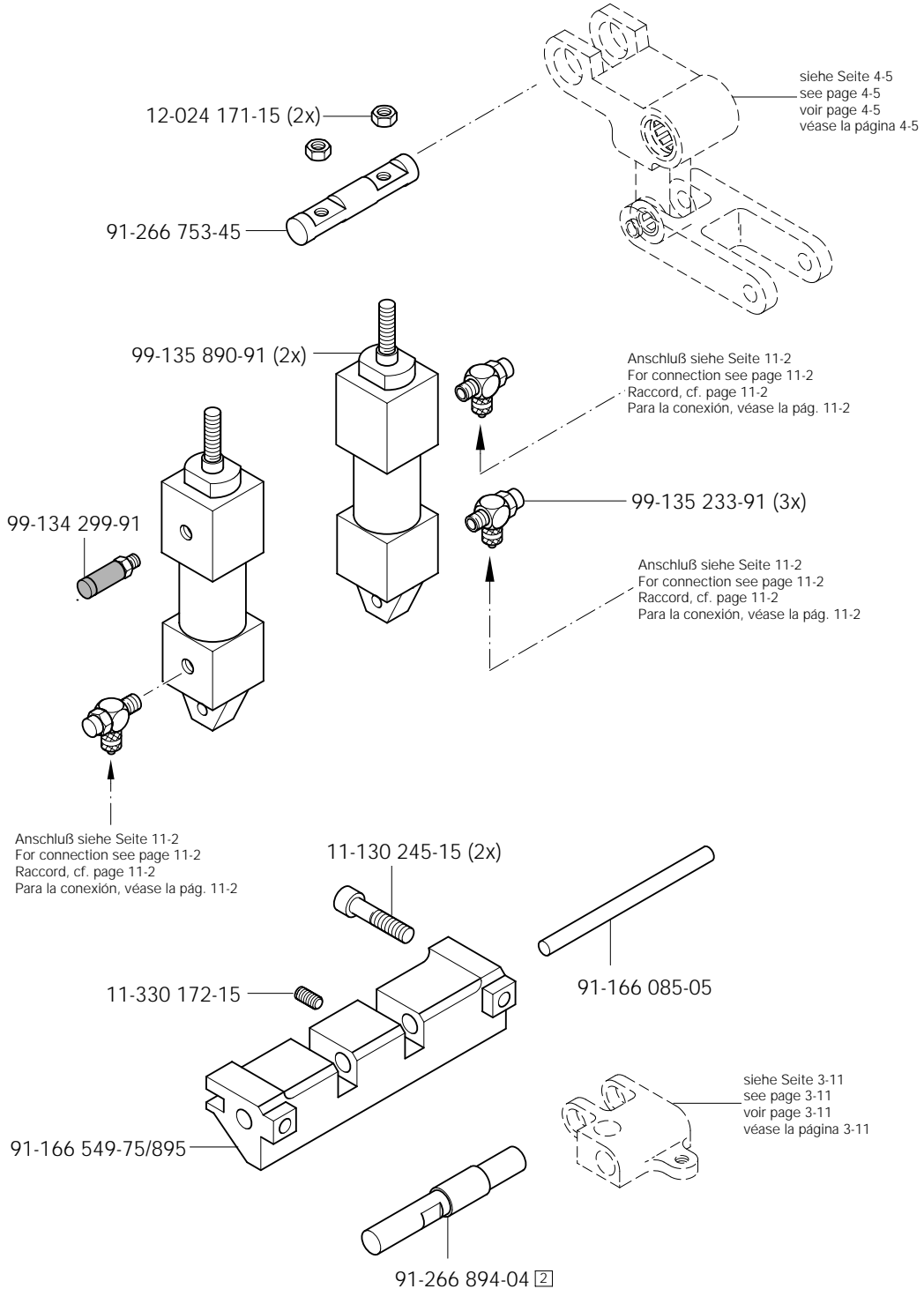
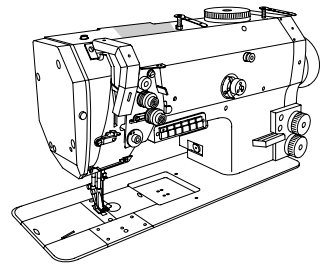



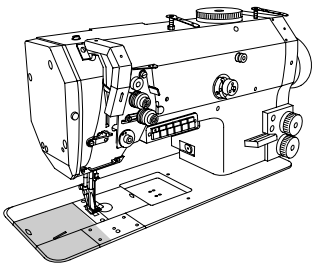

Kanten-Beschneideinrichtung (-731/02)  
 Edge trimmer (-731/02)  
 Couteau (-731/02)  
 Recortador (-731/02)

PFAFF 1525-900/81

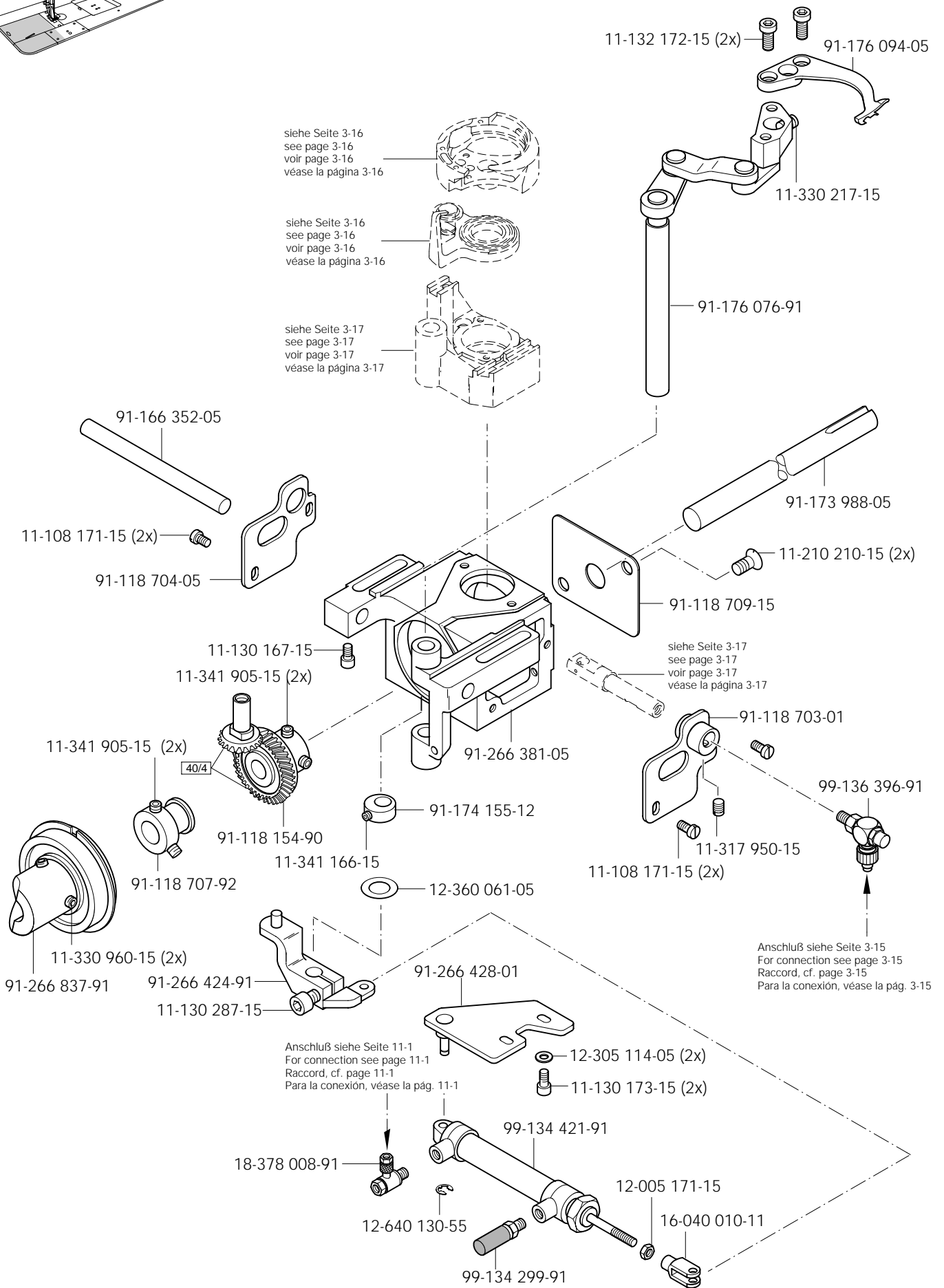

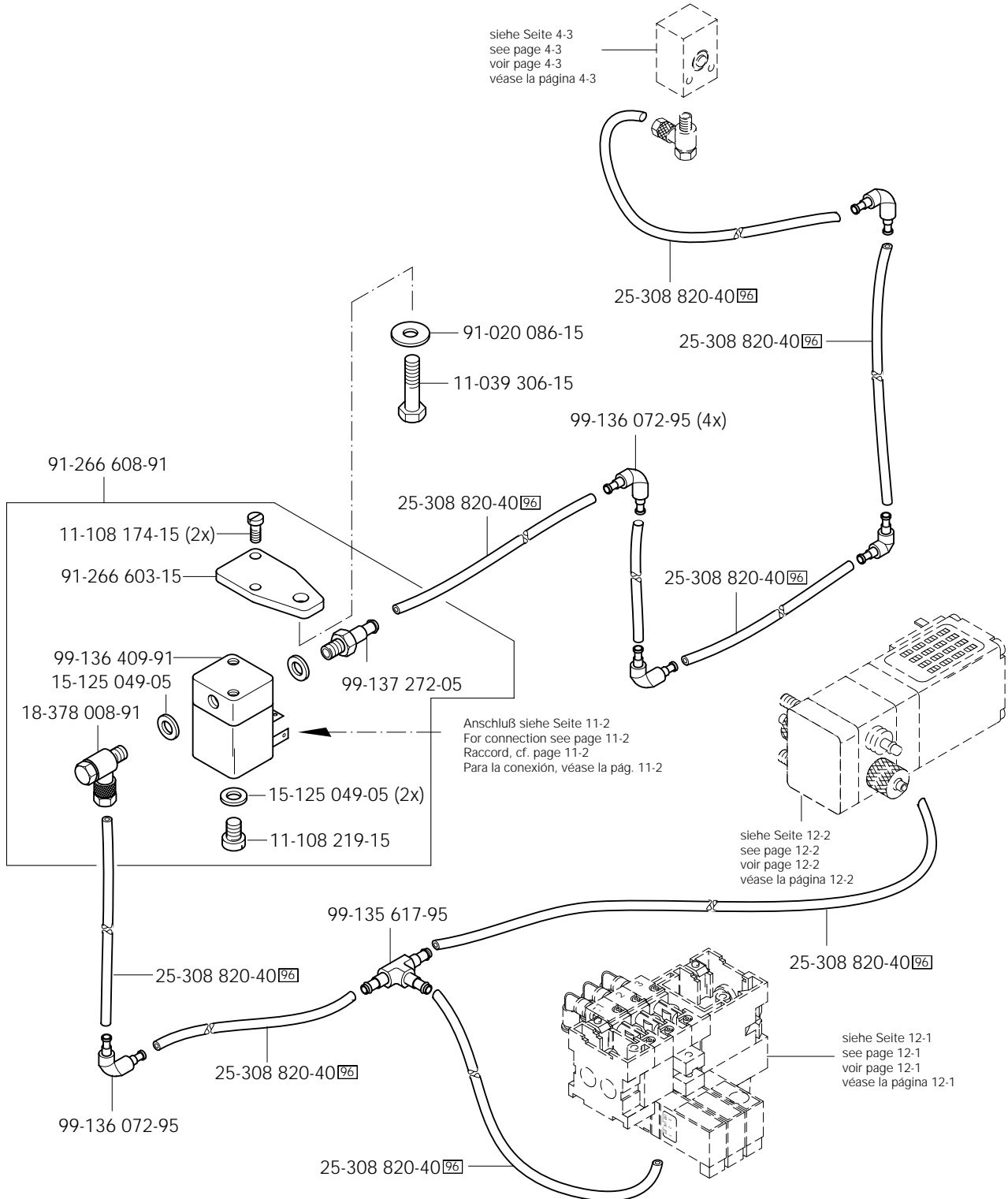
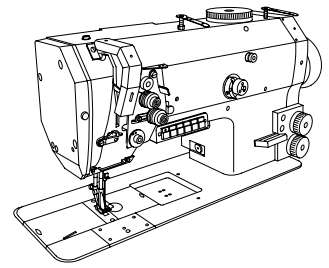

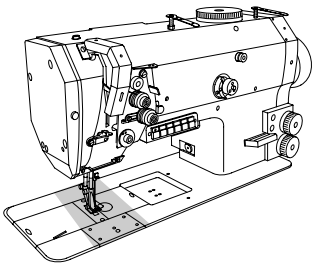

Greifersystem mit Anhaltenocken an der Stichplatte (-901/01)  
 Gripper system with stop cam on the stitching plate (-901/01)  
 Système crochet avec mentonnet de retenue à la plaque à aiguille (-901/01)  
 Sistema de agarre con levas de parada en la placa de aguja (-901/01)

PFAFF 1525-900/81

5

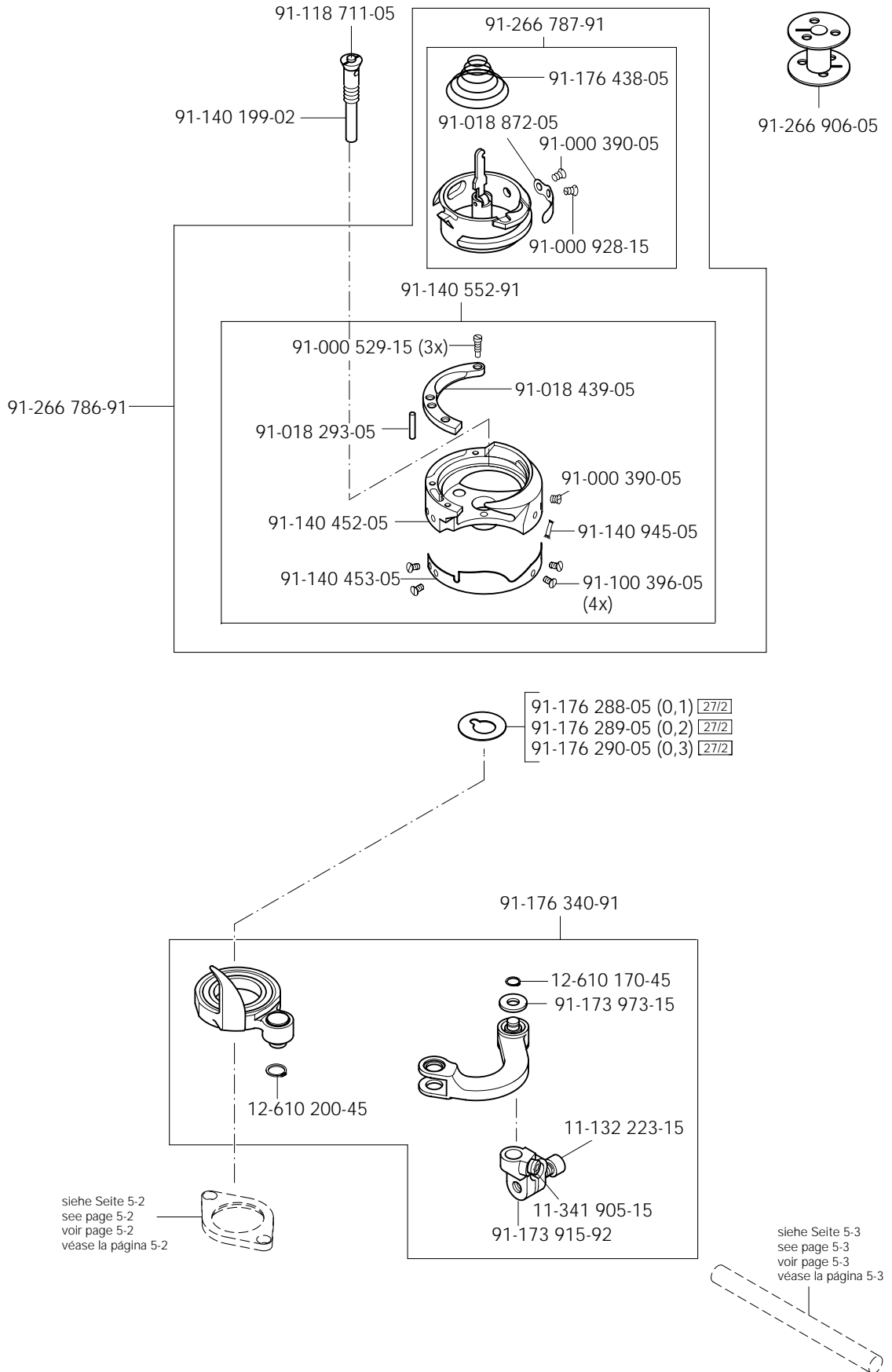

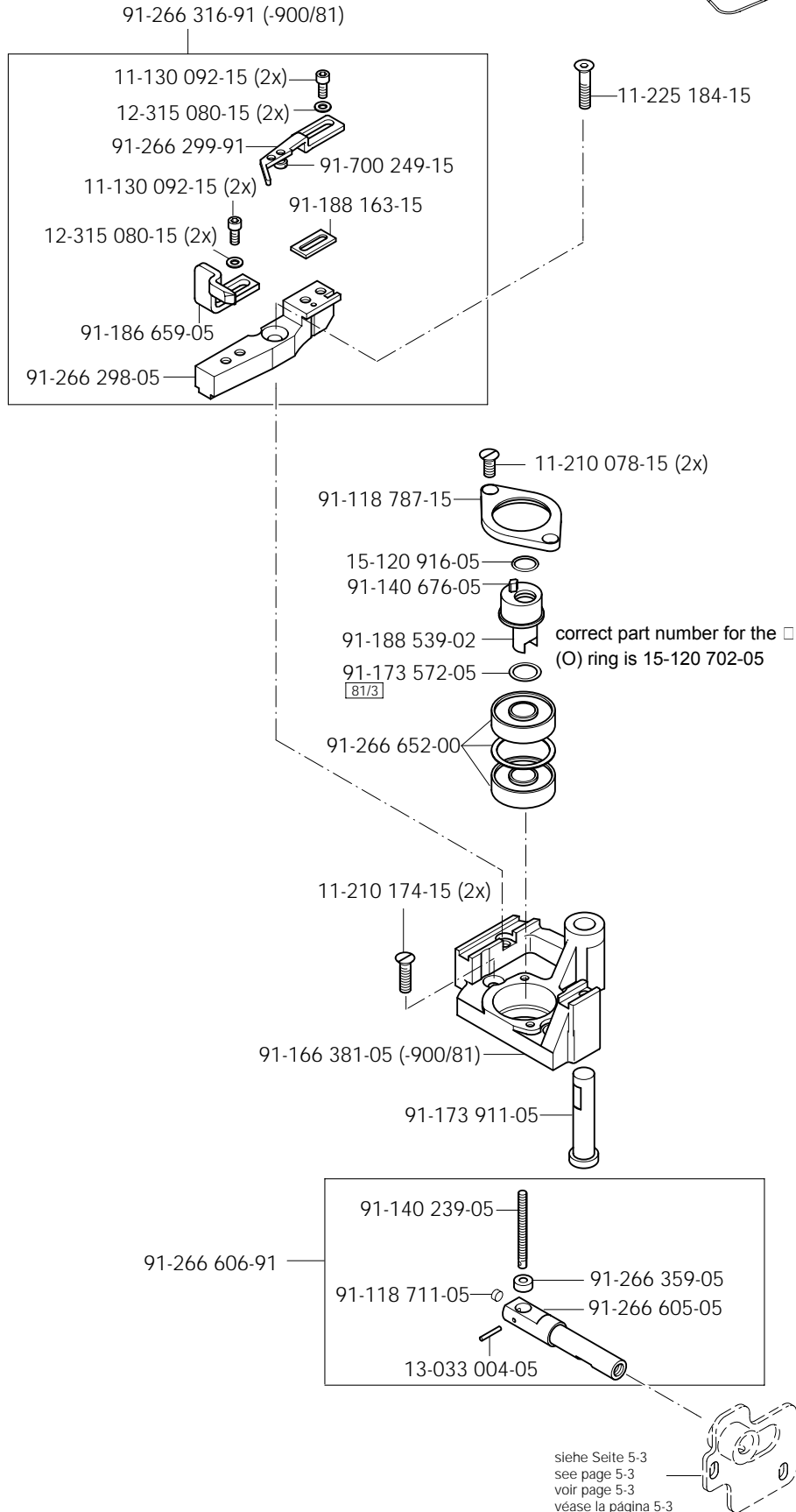
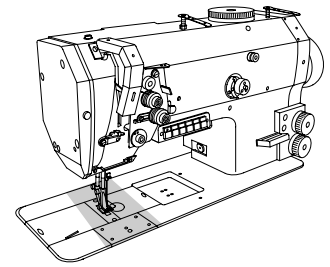

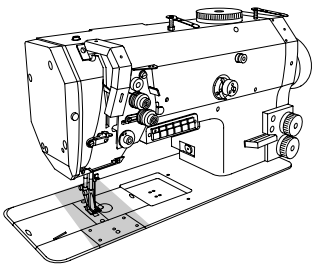

Greifersystem mit Anhaltenocken an der Stichplatte (-901/01)

PFAFF 1525-900/81

Gripper system with stop cam on the stitching plate (-901/01)

Système crochet avec mentonnet de retenue à la plaque à aiguille (-901/01)

Sistema de agarre con levas de parada en la placa de aguja (-901/01)

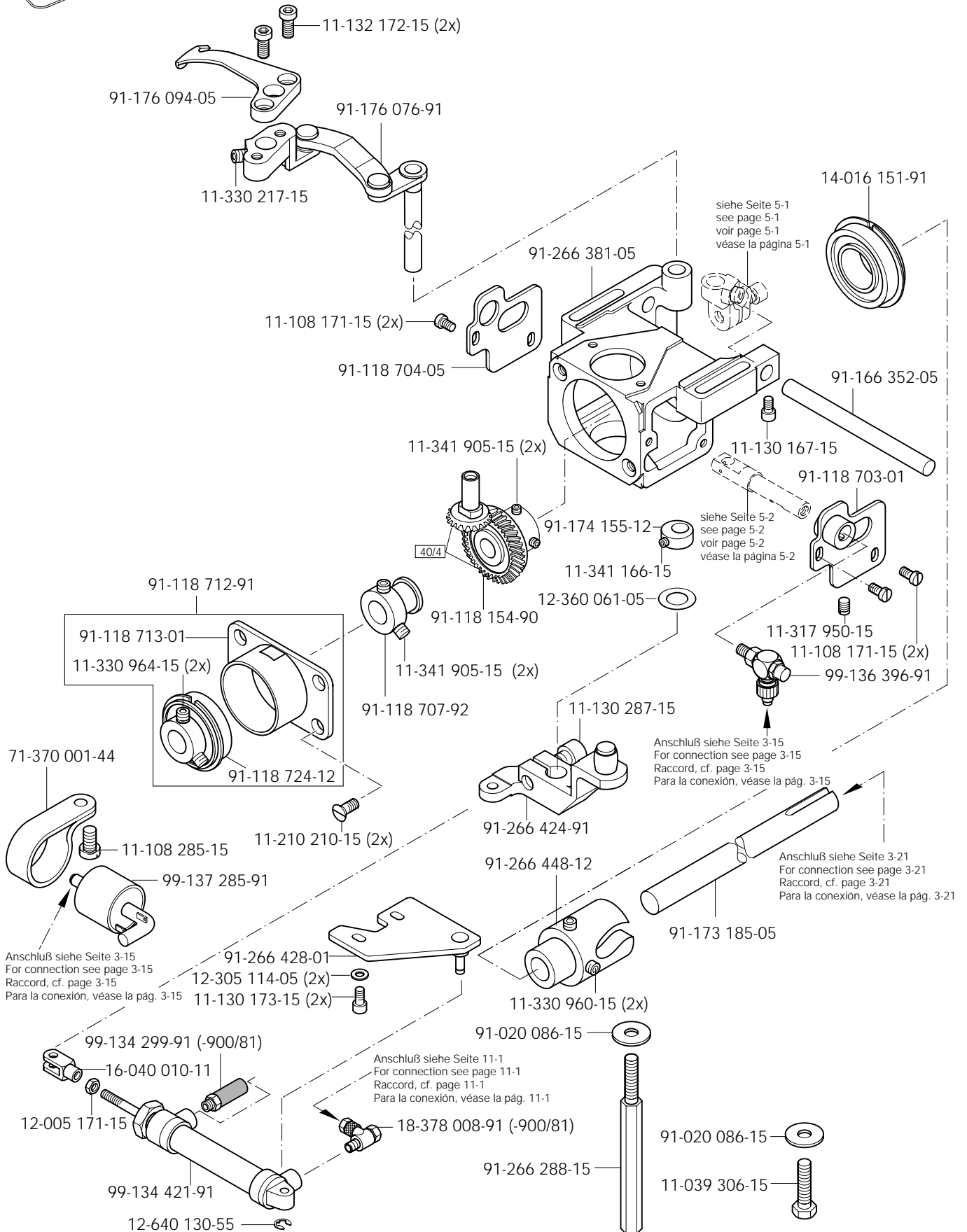

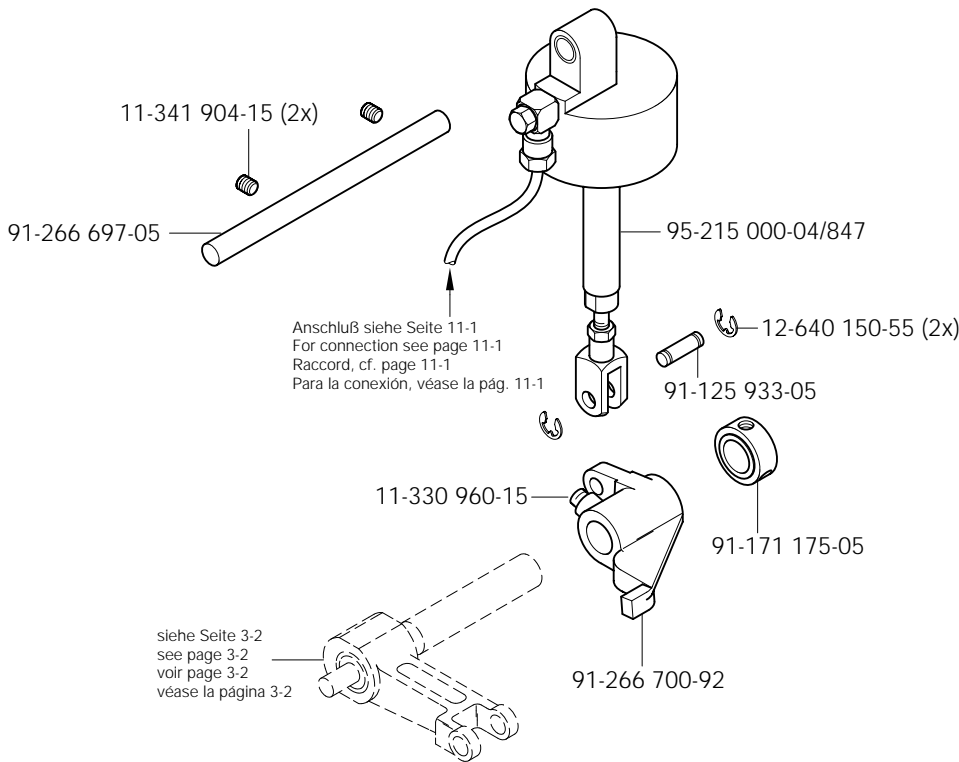
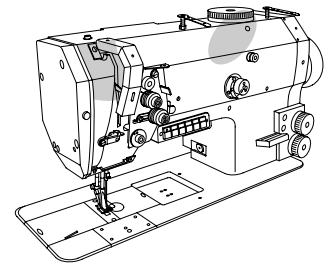

(PFAFF 1525 -731/02; -900/81)

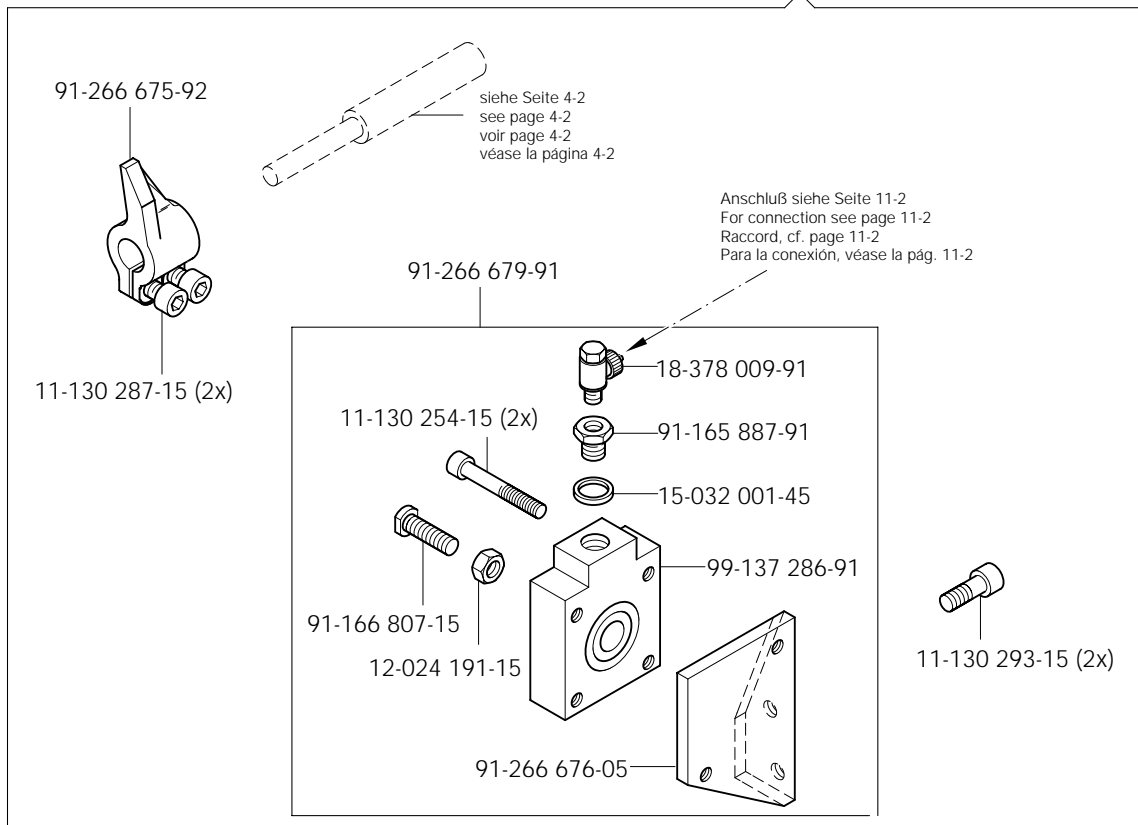

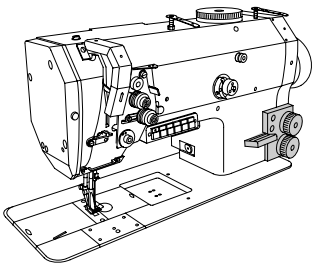

Verriegelungs-Einrichtung (-911/35)  
 Backtacking mechanism (-911/35)  
 Dispositif à points d'arrêt (-911/35)  
 Rematador (-911/35)

PFAFF 1525  
 PFAFF 1526

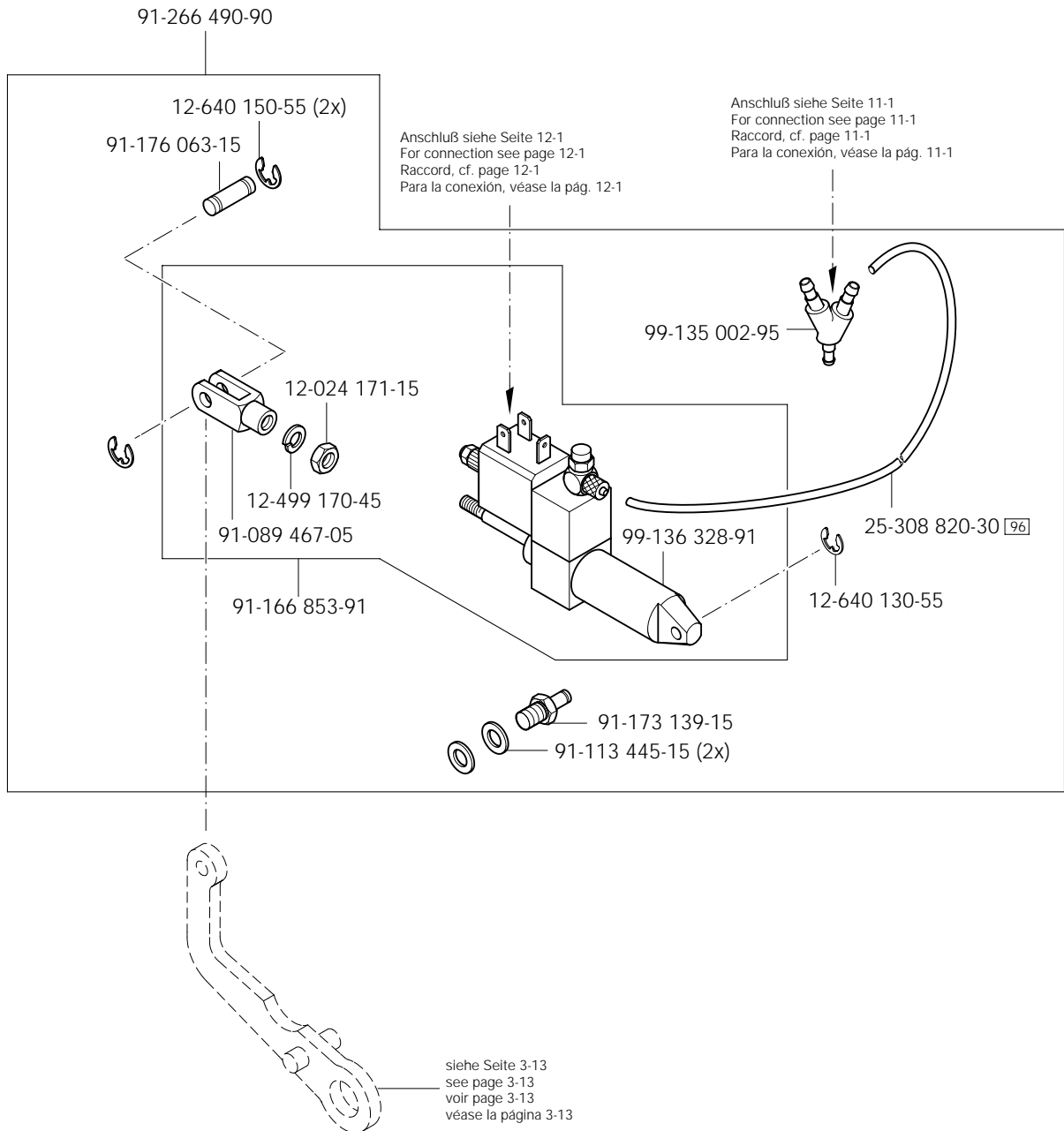

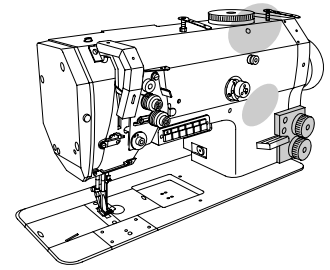

(-918/09)

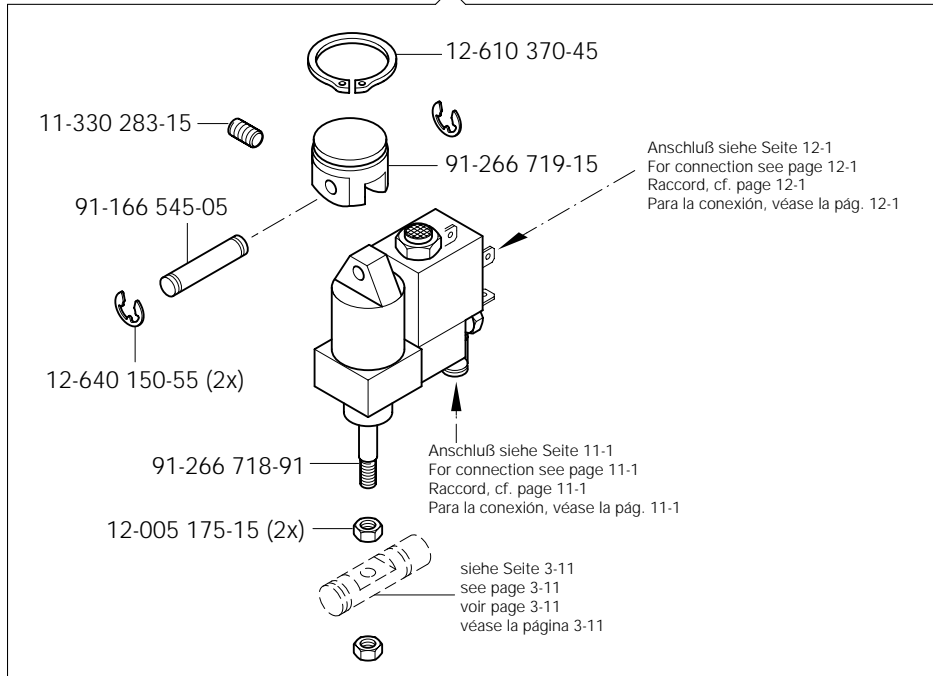

(-918/26)

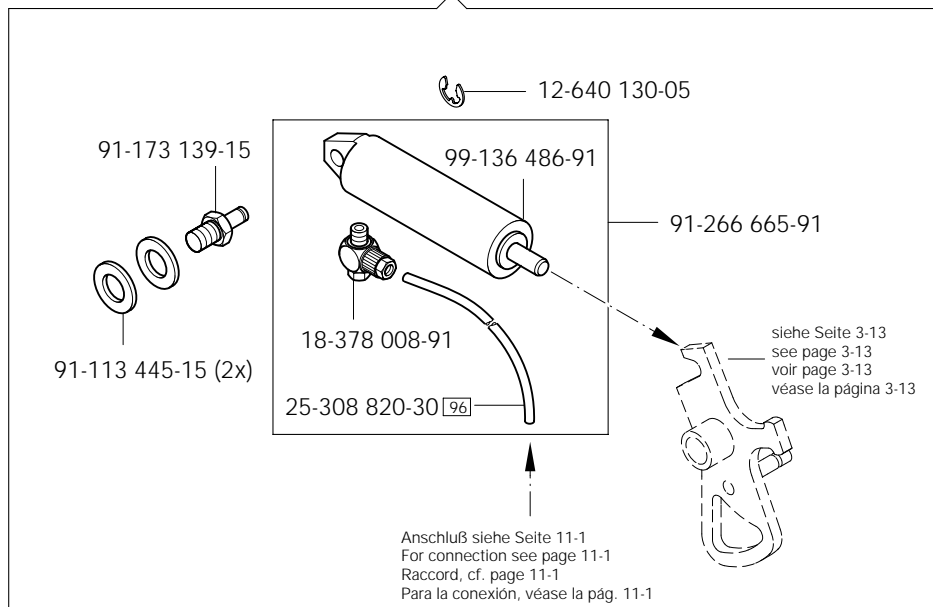



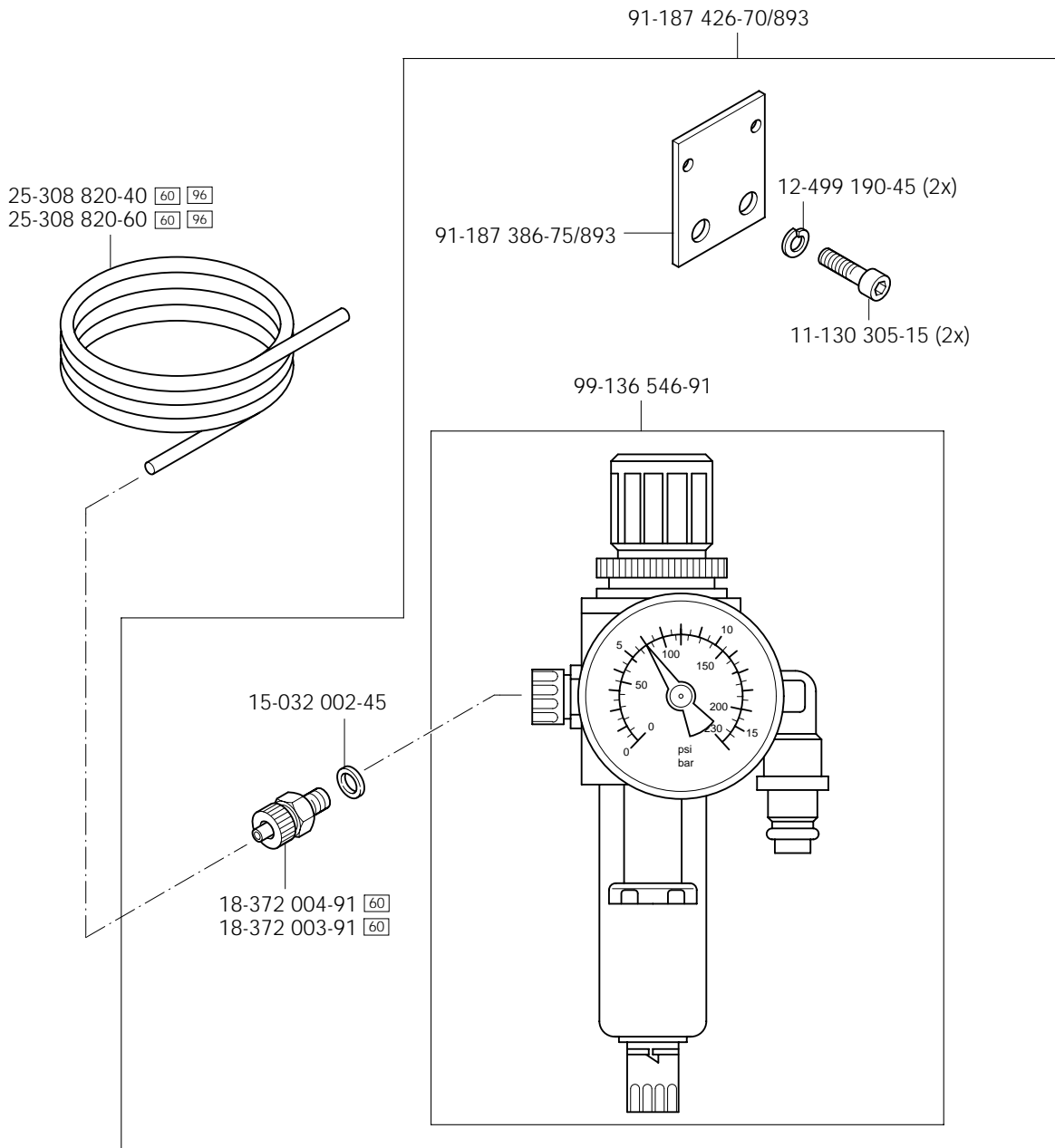

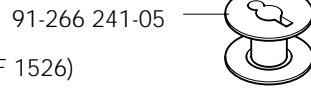
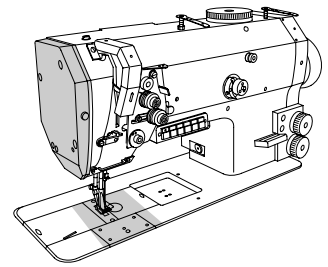

(PFAFF 1526)

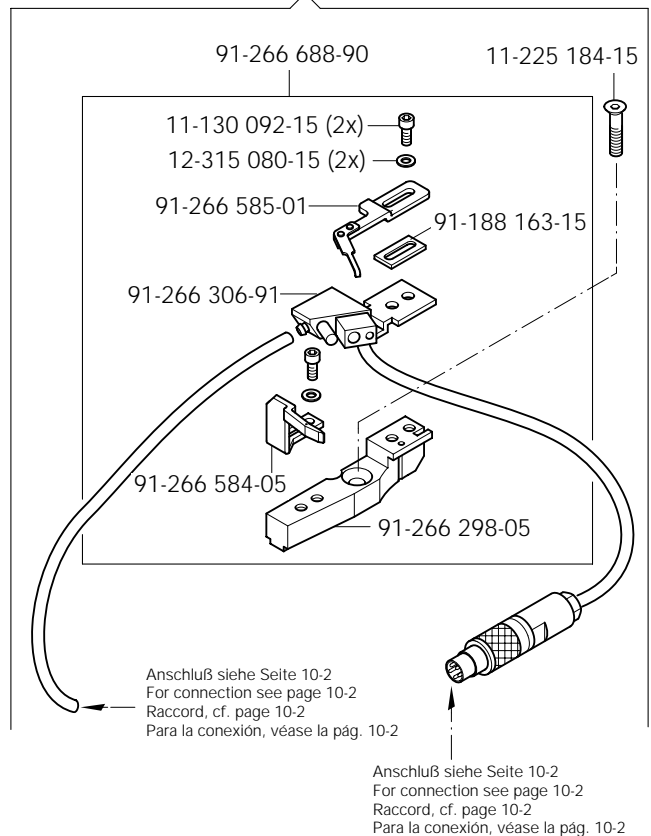
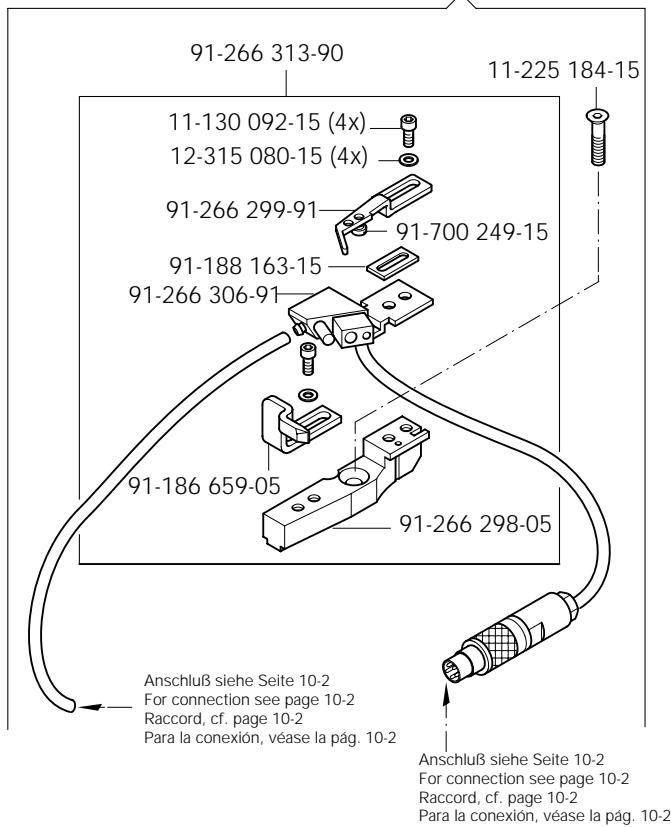
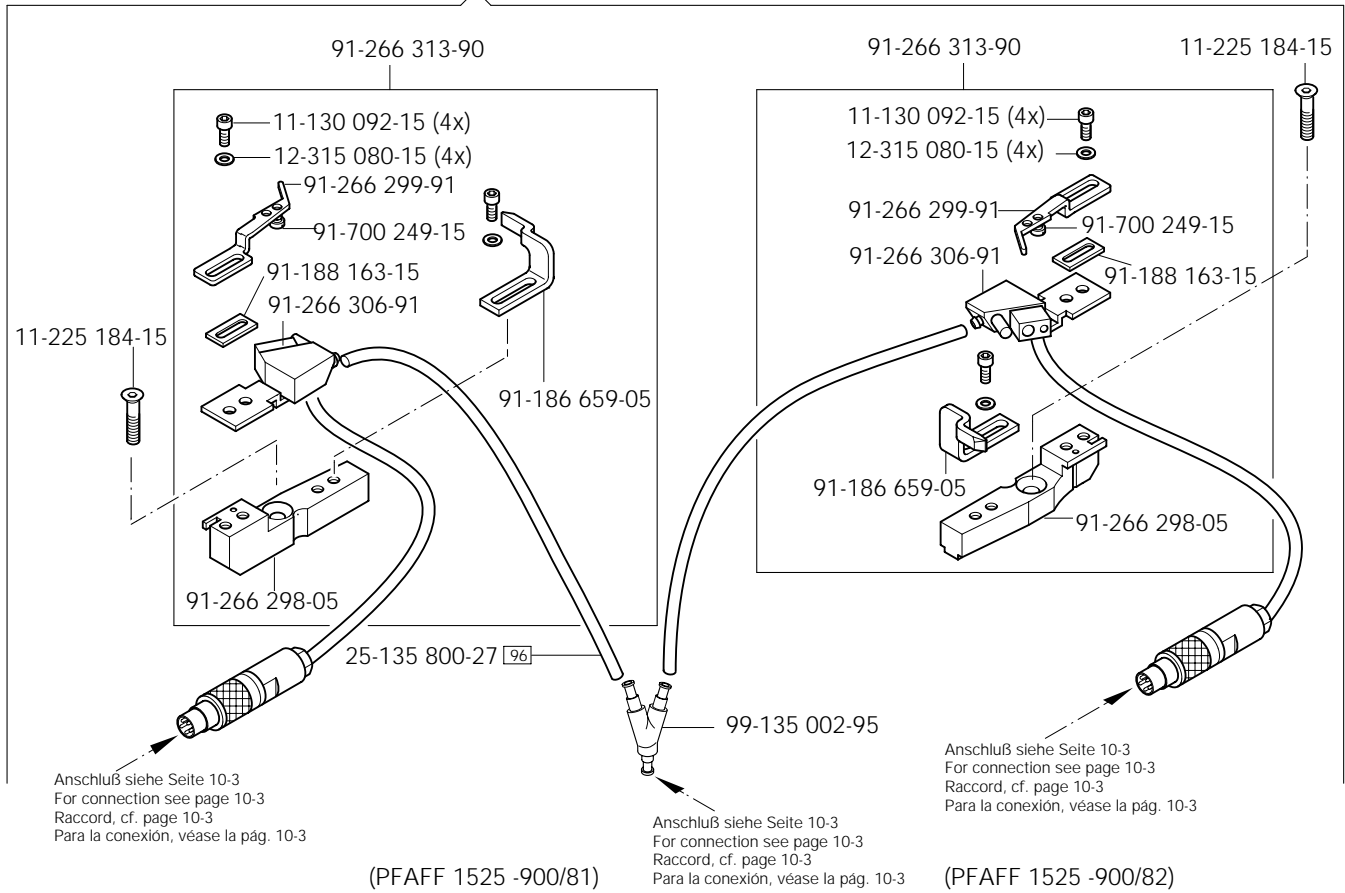

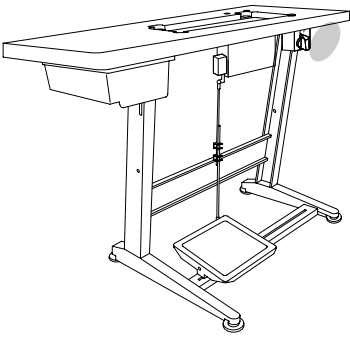

Spulfadenvorratwächter (-926/06)  
 Bobbin thread supply monitor (-926/06)  
 Contrôleur de canette (-926/06)  
 Detector del hilo de la canilla (-926/06)

PFAFF 1525

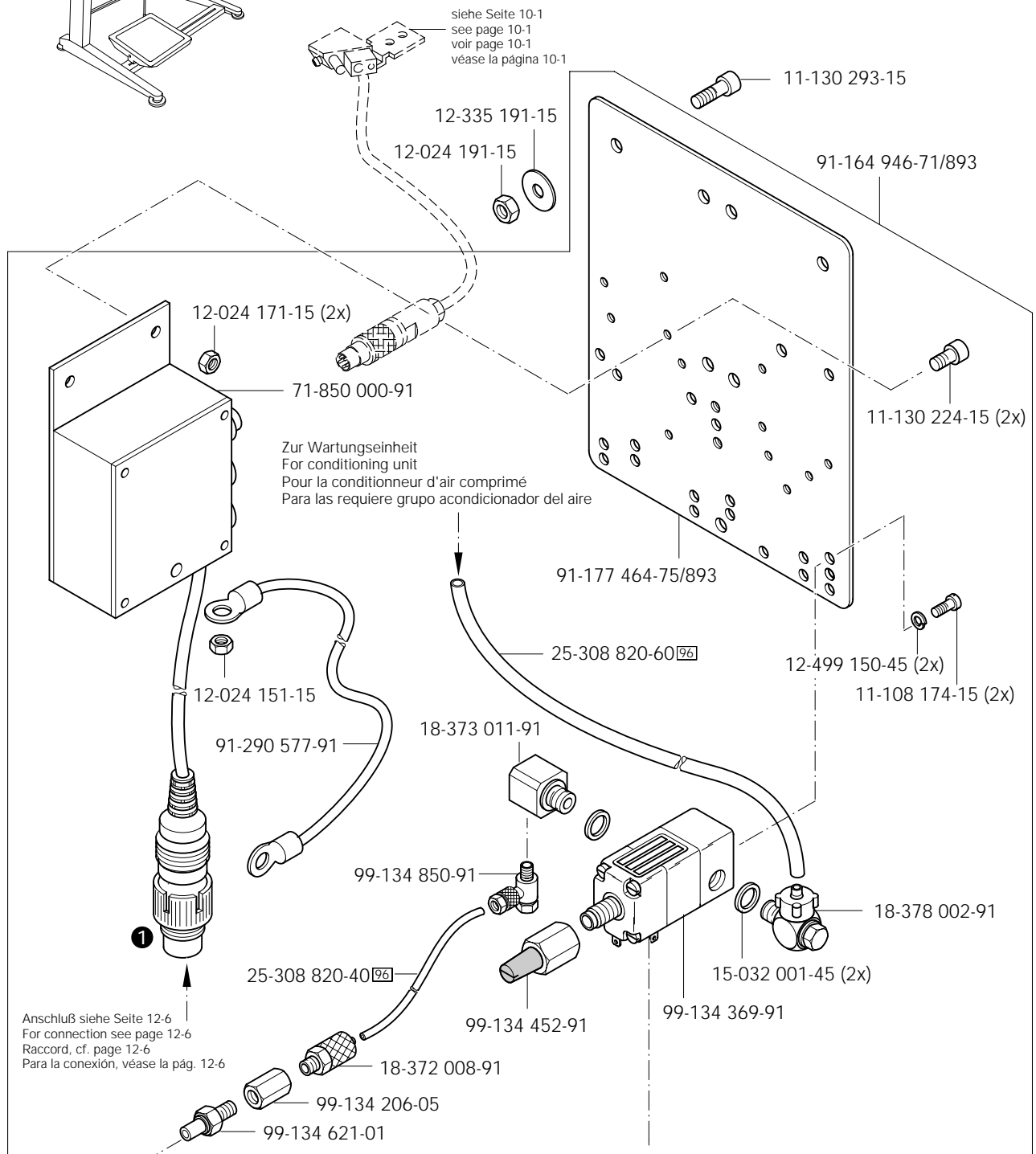

1  
 Anschluß siehe Seite 12-6  
 For connection see page 12-6  
 Raccord, cf. page 12-6  
 Para la conexión, véase la pág. 12-6

10  
 Anschluß siehe Seite 10-1  
 For connection see page 10-1  
 Raccord, cf. page 10-1  
 Para la conexión, véase la pág. 10-1

10  
 Anschluß siehe Seite 12-2  
 For connection see page 12-2  
 Raccord, cf. page 12-2  
 Para la conexión, véase la pág. 12-2

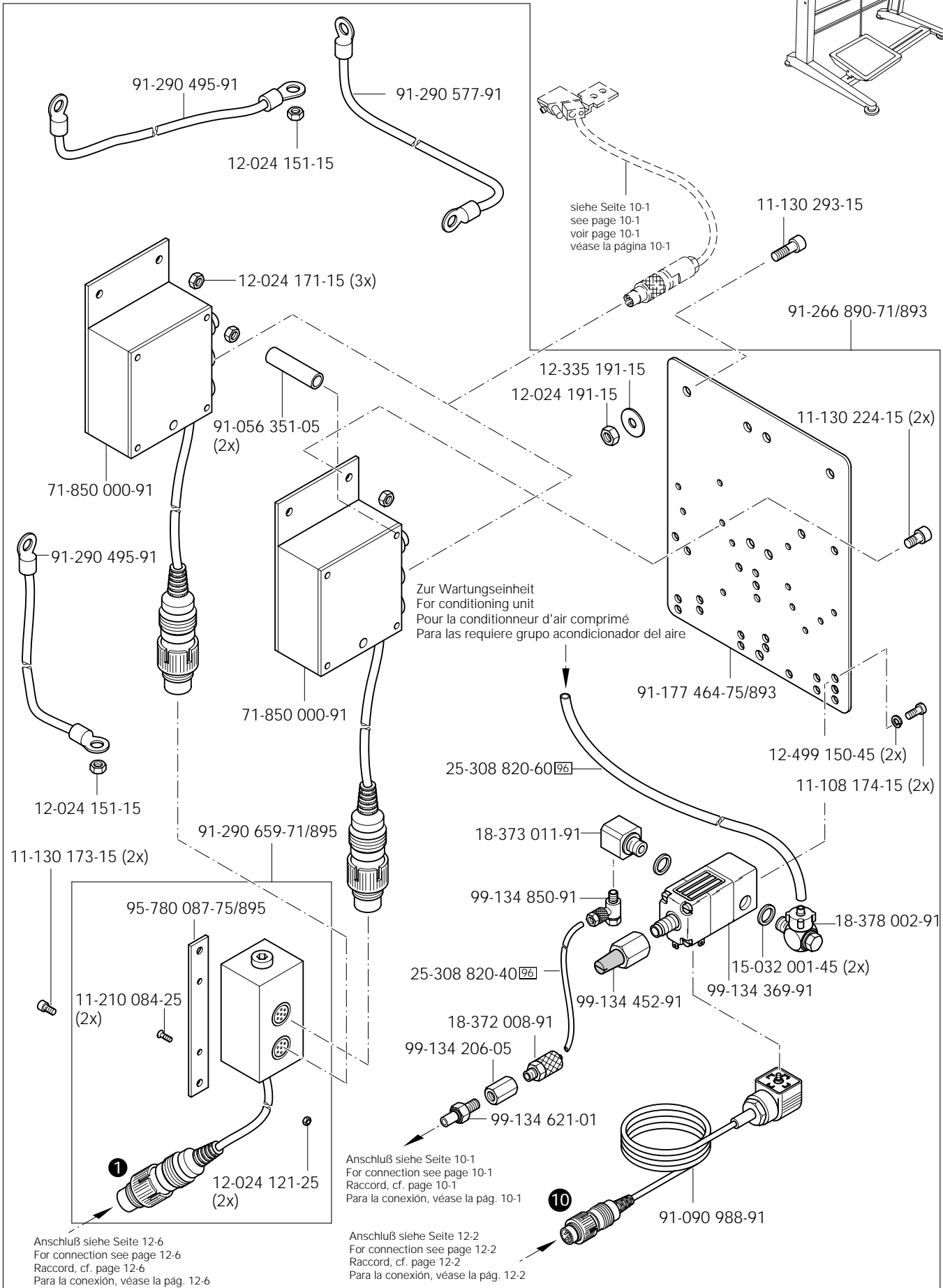
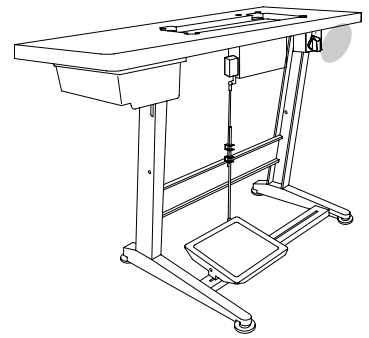

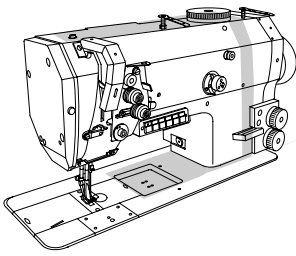

Pneumatische Ausrüstung  
 Pneumatic equipment  
 Equipement pneumatique  
 Equipo neumático

PFAFF 1525  
 PFAFF 1526

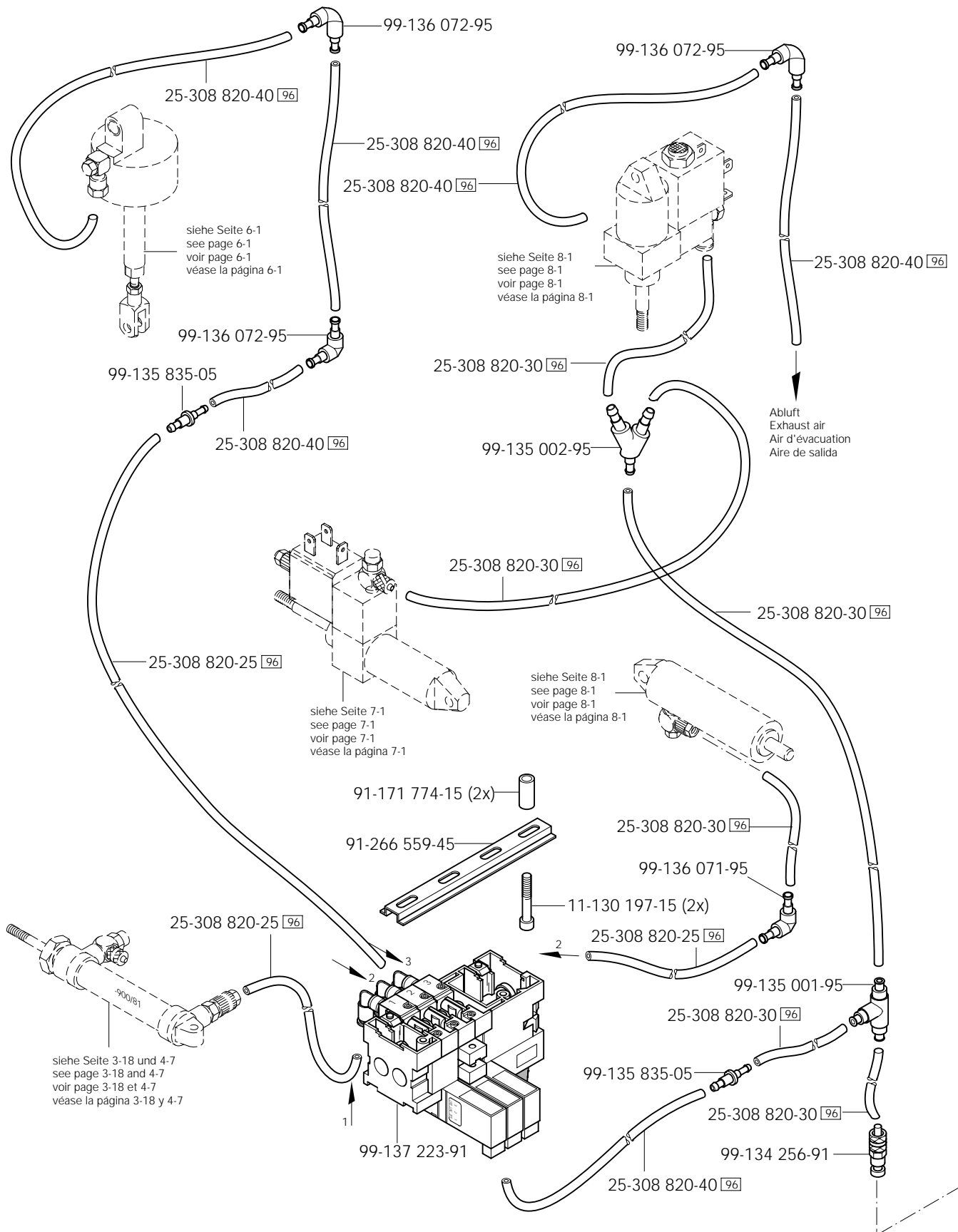

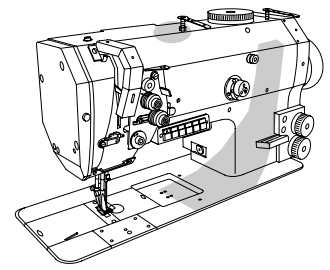

(-731/02)

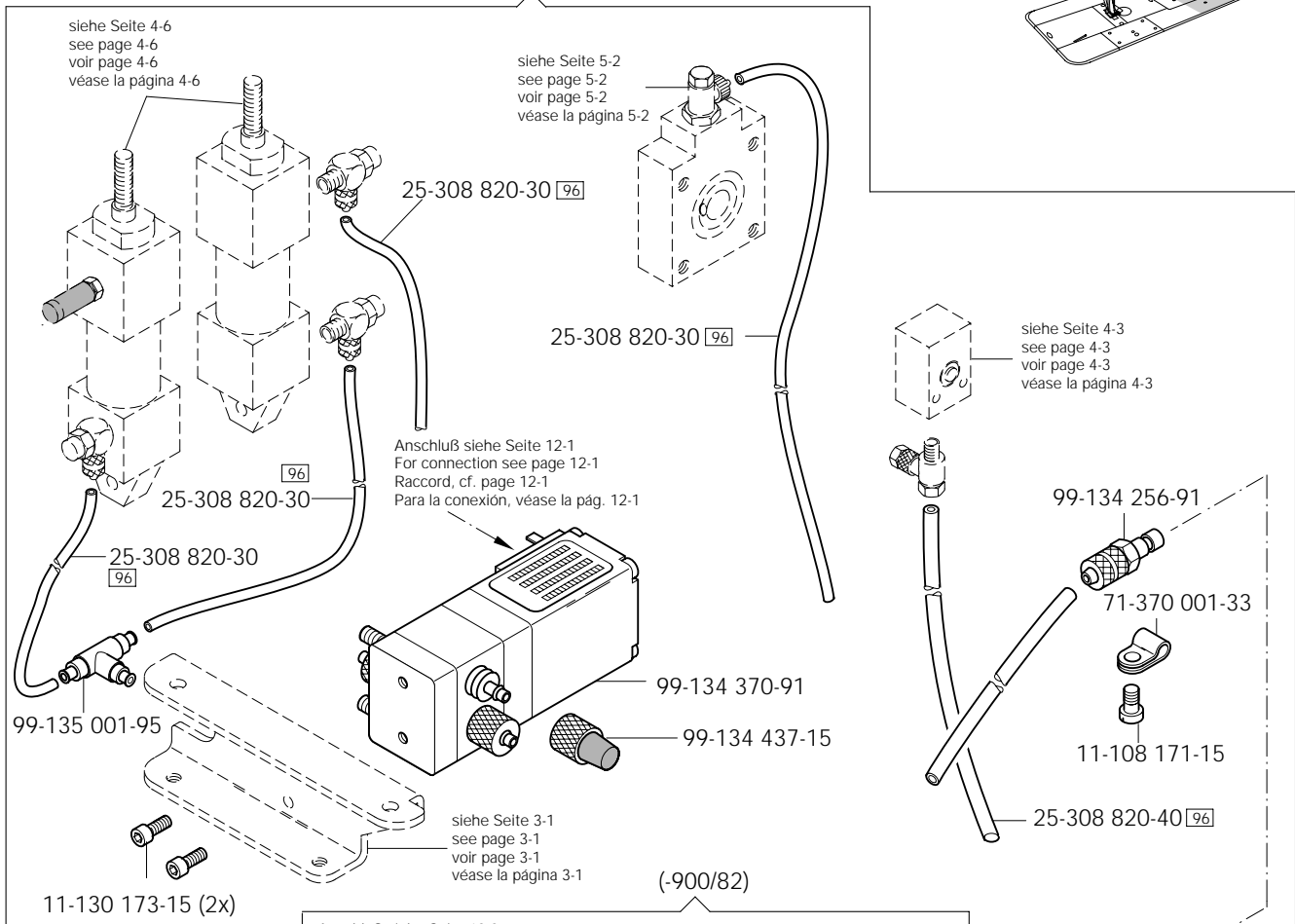

(-900/82)

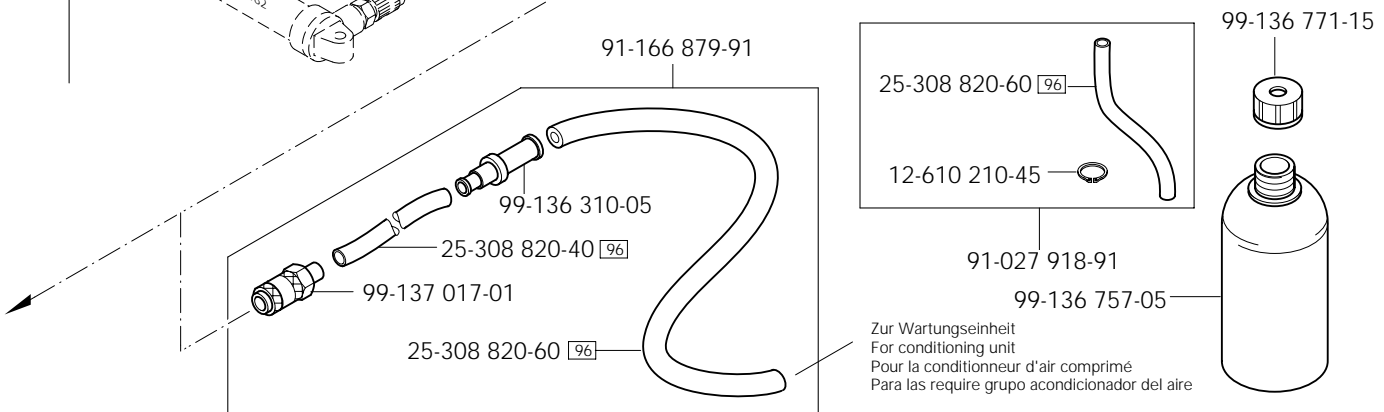
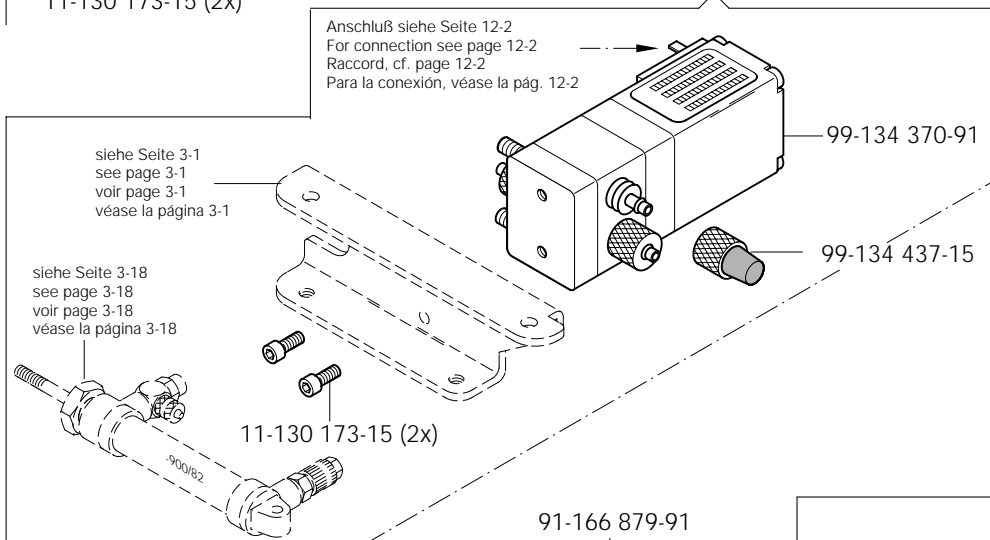

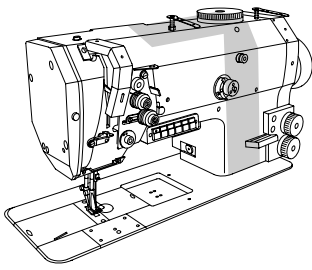

Kabelbaum zum Oberteil  
 Cable tree to sewing head  
 Faisceau de câbles vers la tête de machine  
 Mazo de cables para el cabezal

PFAFF 1525  
 PFAFF 1526

12.01

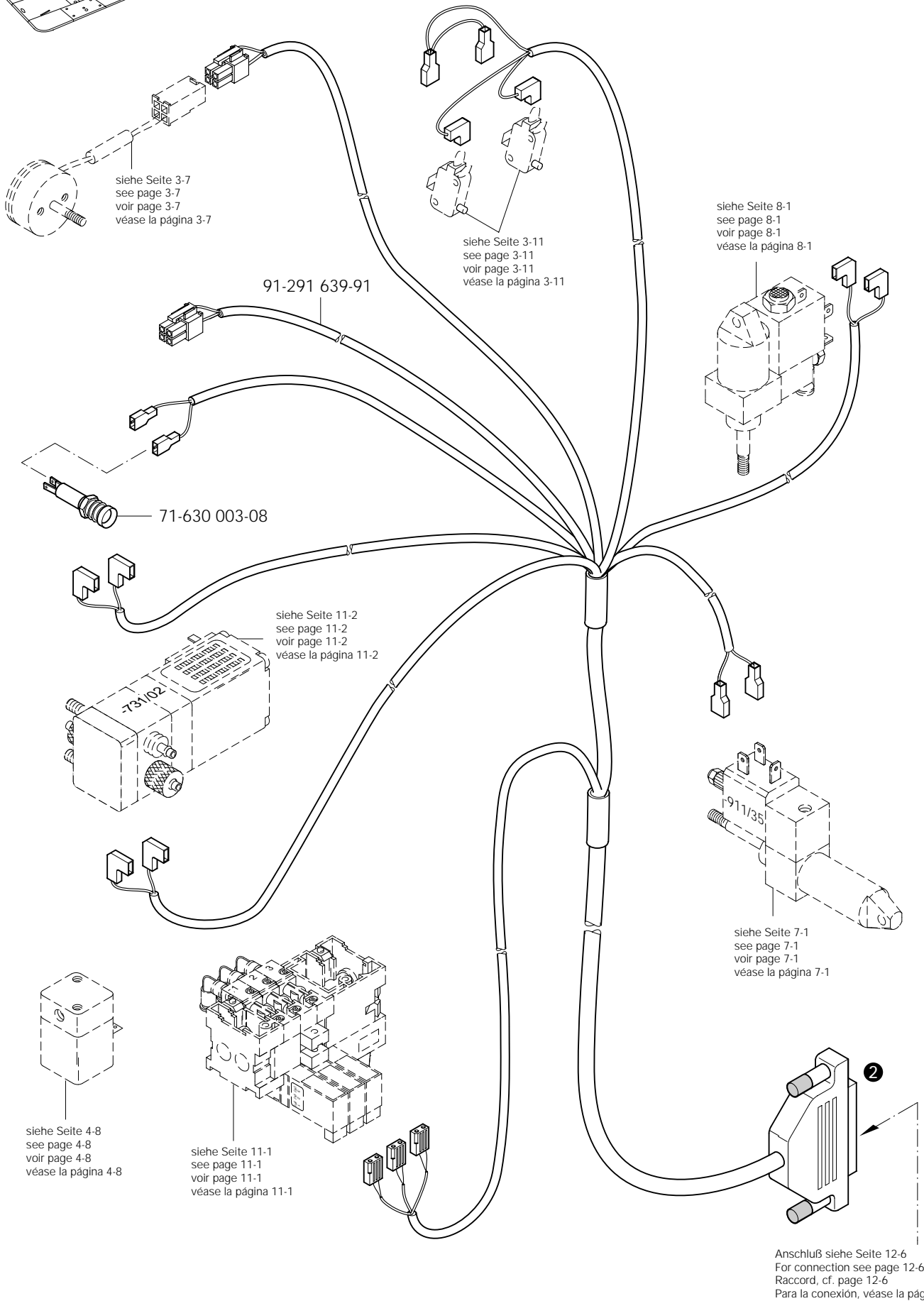

# 12.01

Kabelbaum zum Oberteil  
 Cable tree to sewing head  
 Faisceau de câbles vers la tête de machine  
 Mazo de cables para el cabezal

PFAFF 1525  
 PFAFF 1526

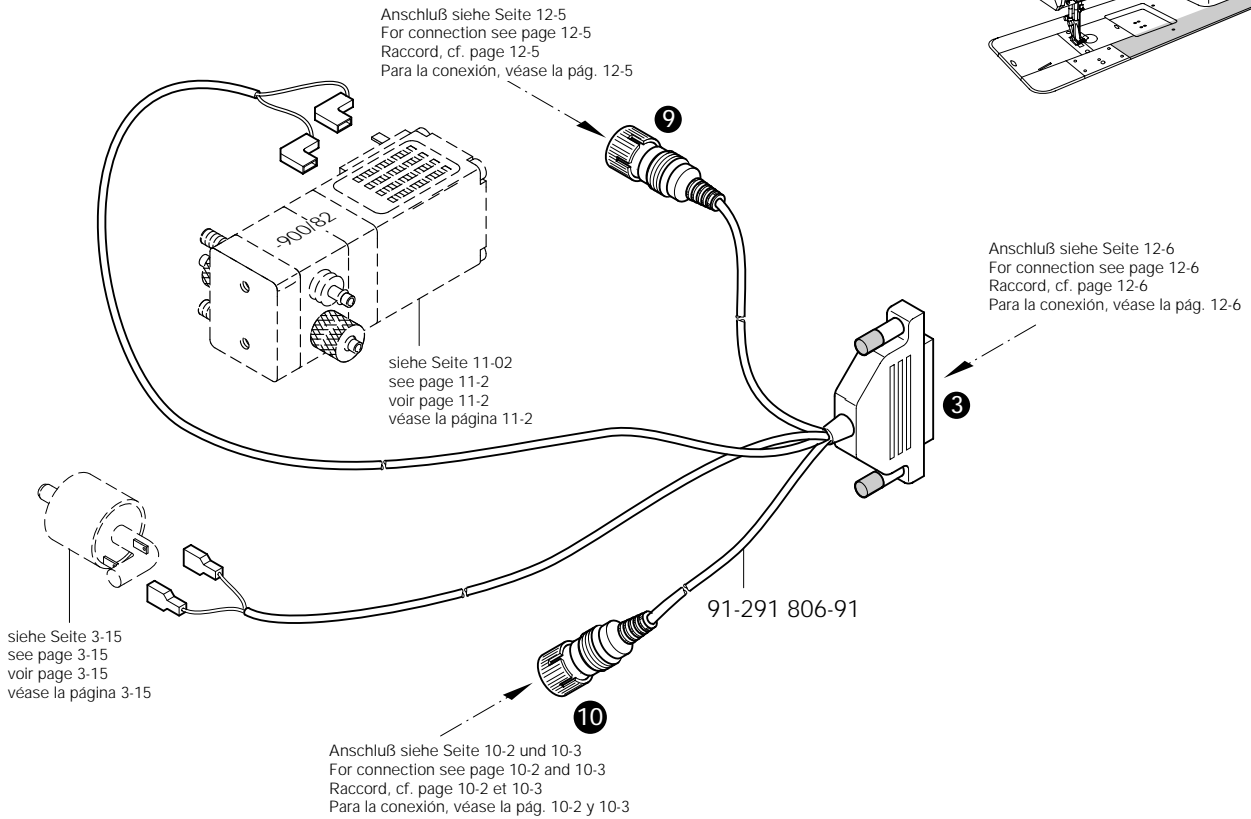
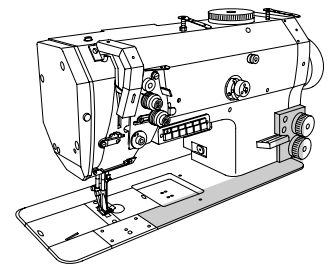

# 12.02

Tastenschalter  
 Push-button switch  
 Interrupteur à bouton-poussoir  
 Interruptor pulsador

PFAFF 1525  
 PFAFF 1526

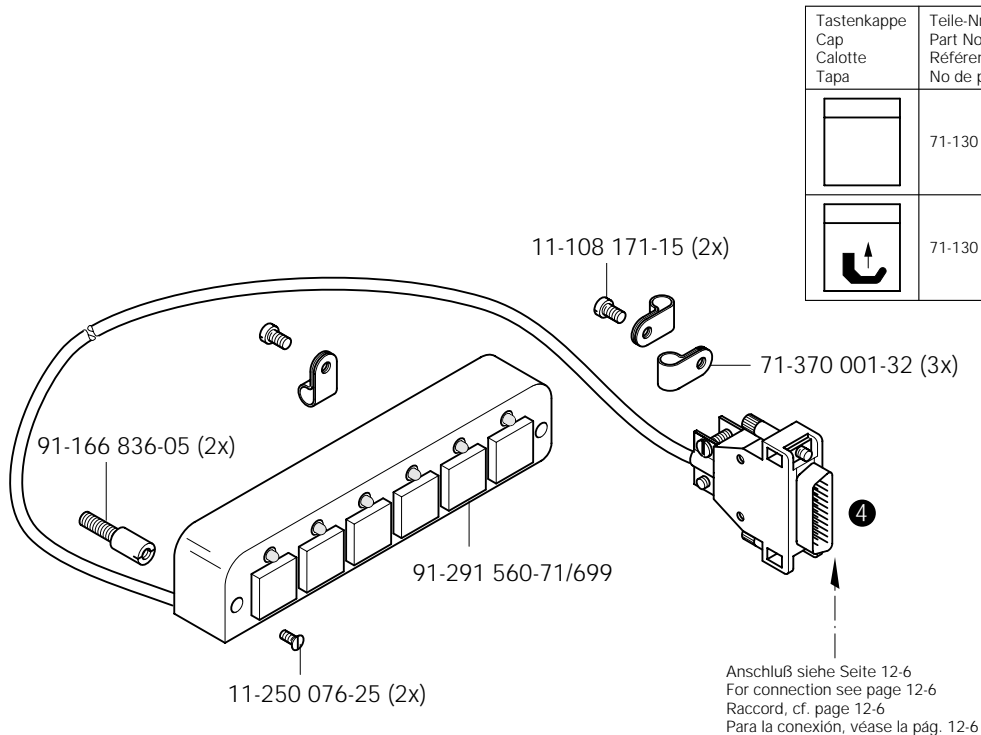
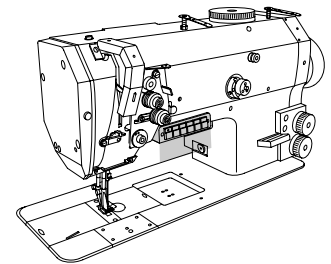

Tastenkappe Cap Calotte Tapa	Teile-Nr. Part No. Référence No de pieza
	71-130 006-02
	71-130 006-23

Tastenkappe Cap Calotte Tapa	Teile-Nr. Part No. Référence No de pieza
	71-130 005-95
	71-130 005-96
	71-130 005-97
	71-130 005-98
	71-130 005-99
	71-130 006-01



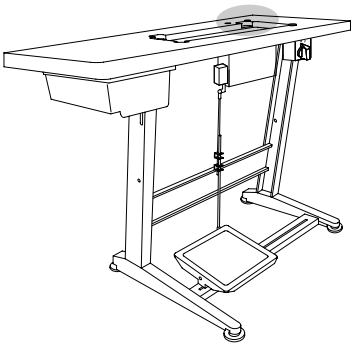

Bedienfeld  
Control panel  
Panneau de commande  
Panel de mandos

PFAFF 1525  
PFAFF 1526

12.03

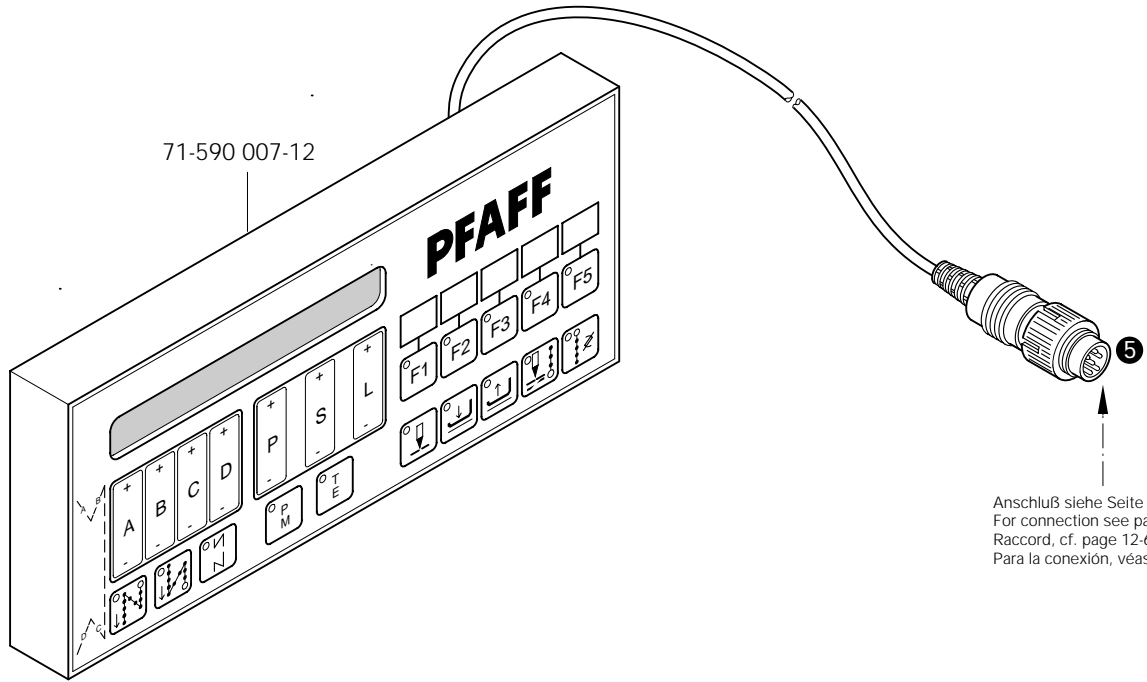

Anschluß siehe Seite 12-6  
For connection see page 12-6  
Raccord, cf. page 12-6  
Para la conexión, véase la pág. 12-6

# 12.04

Positionsgeber  
Synchronizer  
Synchronisateur PFAFF 1525  
Sincronizador PFAFF 1526

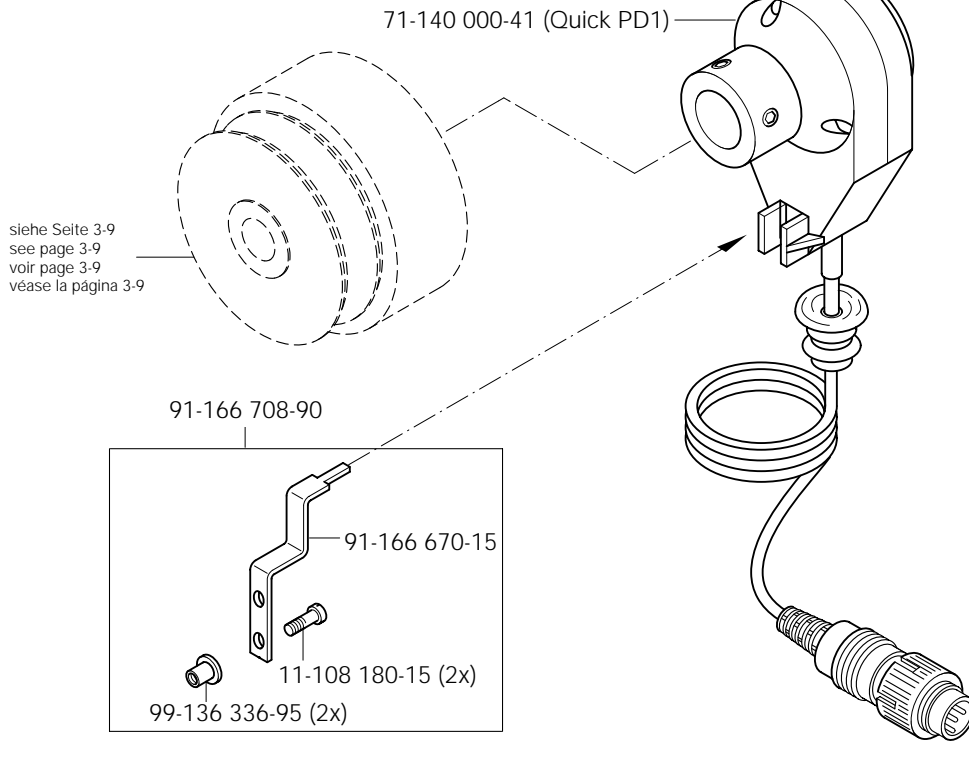
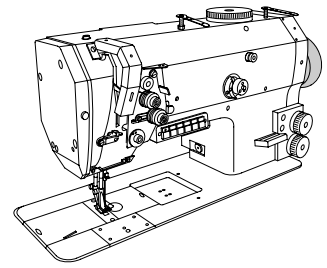

6  
Anschluß siehe Seite 12-6  
For connection see page 12-6  
Raccord, cf. page 12-6  
Para la conexión, véase la pág. 12-6

# 12.05

Sollwertgeber  
Set-point generator  
Codeur PFAFF 1525  
Emisor del valor teórico PFAFF 1526

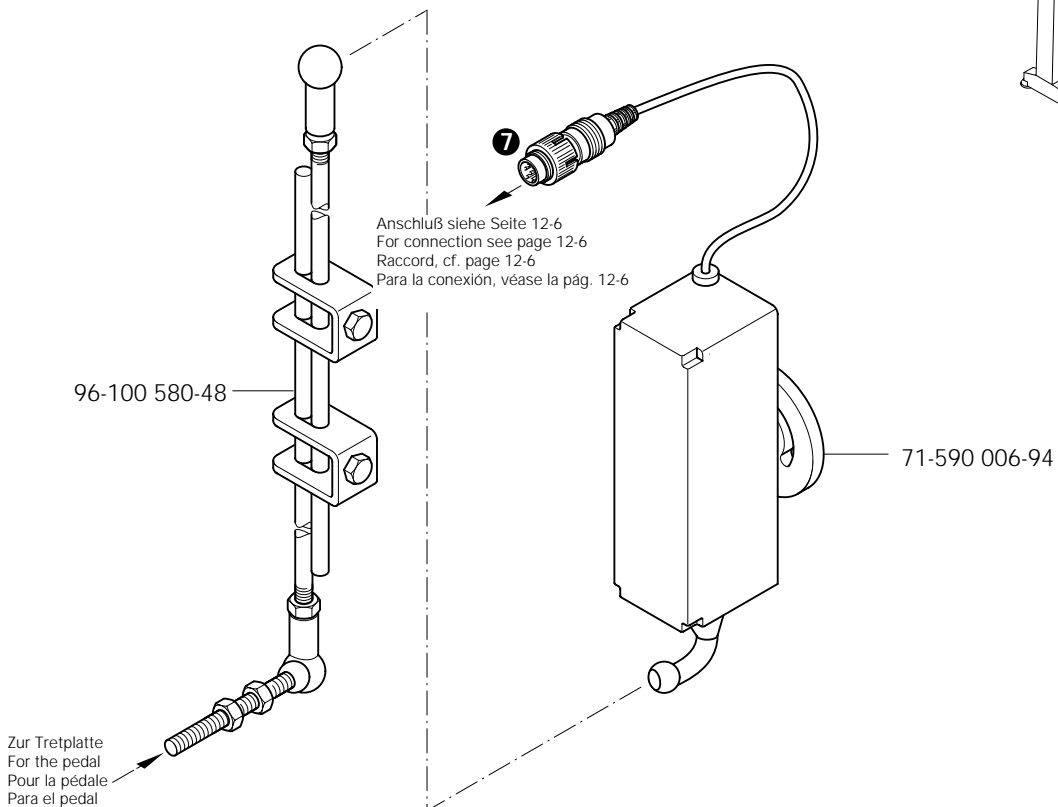
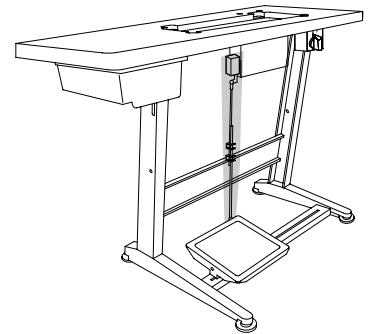

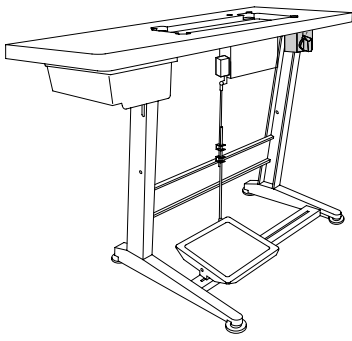

Motordrehschalter  
 Motor turn switch  
 Interrupteur rotatif  
 Interruttore giratorio

PFAFF 1525  
 PFAFF 1526

12.06

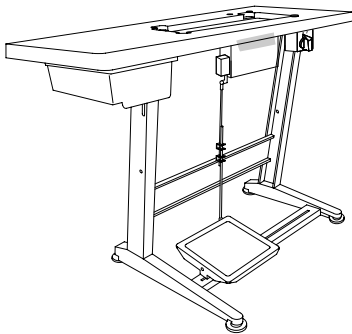
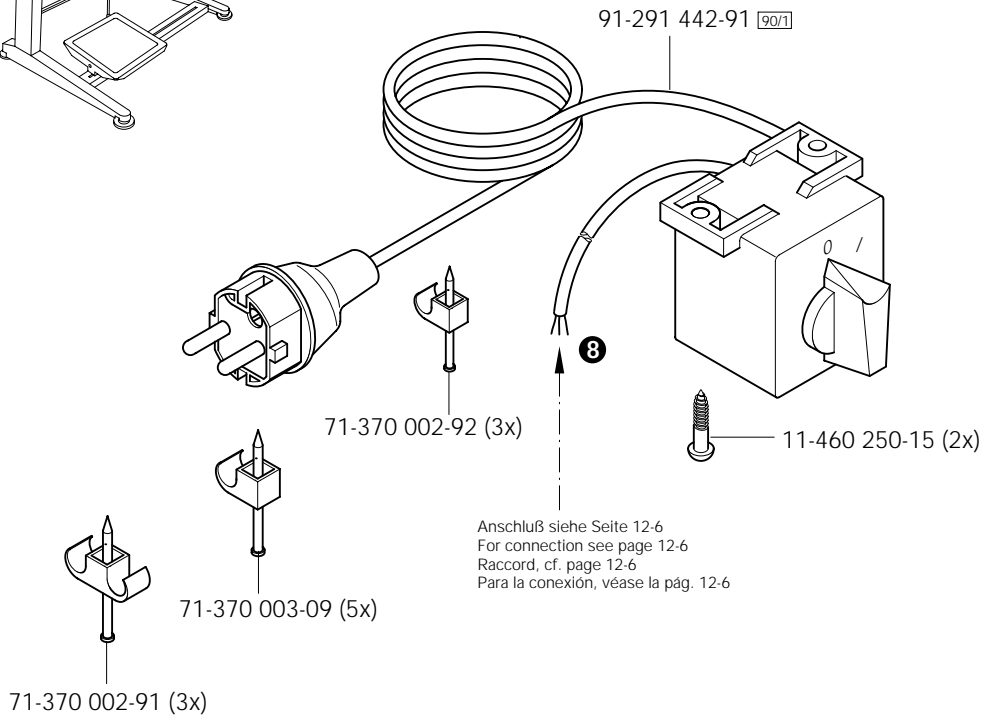

Knietaster mit Leitung  
 Knee switch with cable  
 Interrupteur de genouillère avec câble  
 Interruttore de rodillera con cable

PFAFF 1525  
 PFAFF 1526

12.07

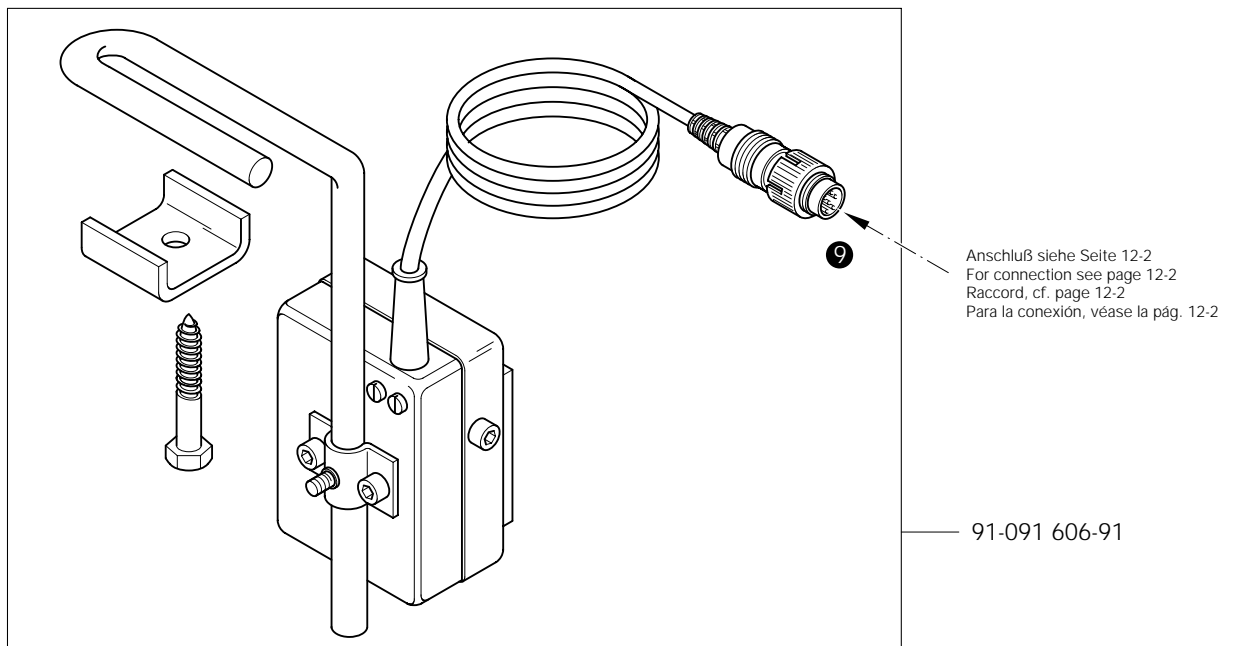

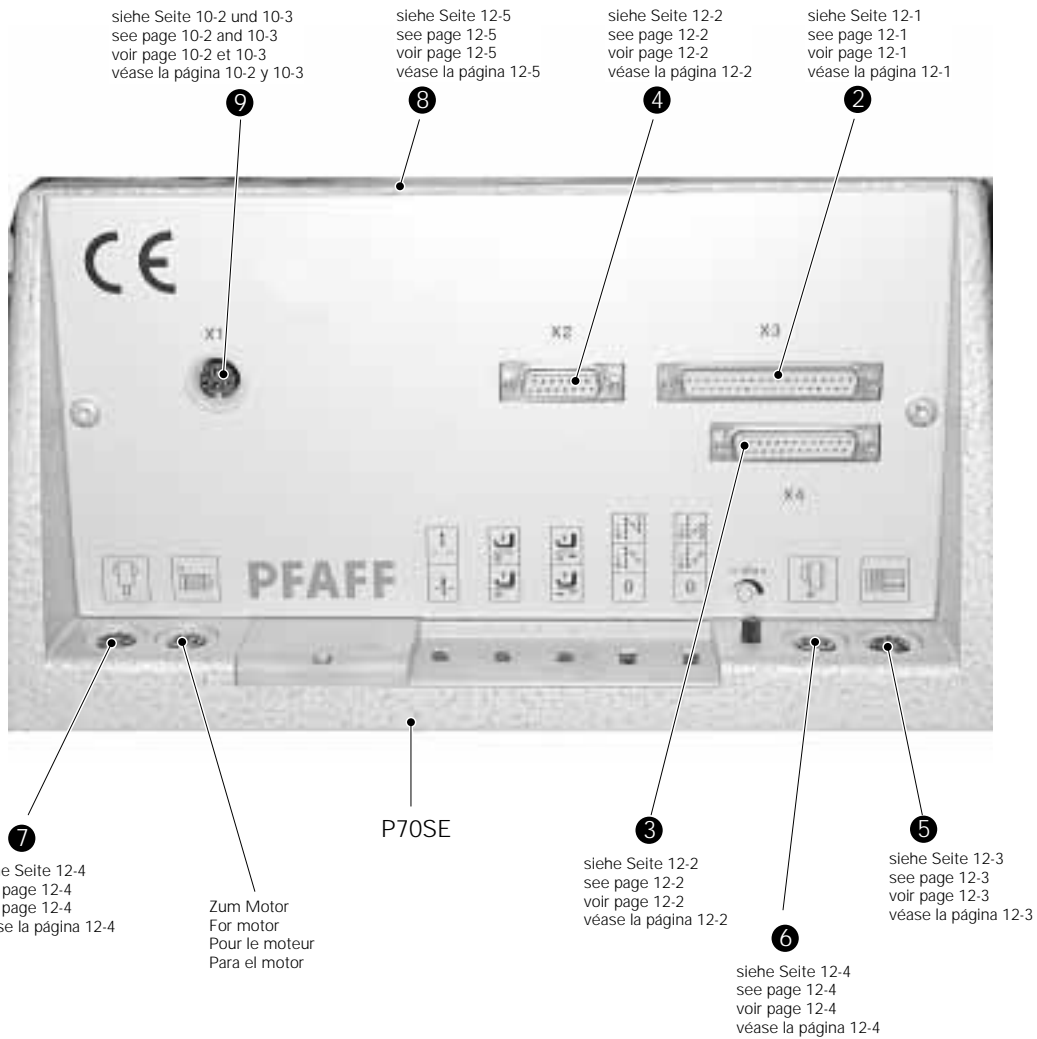
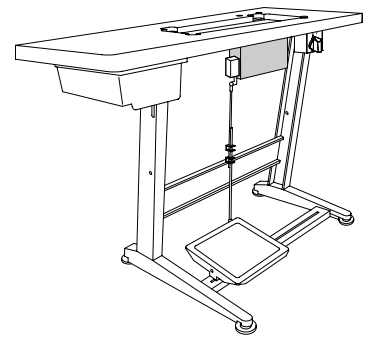

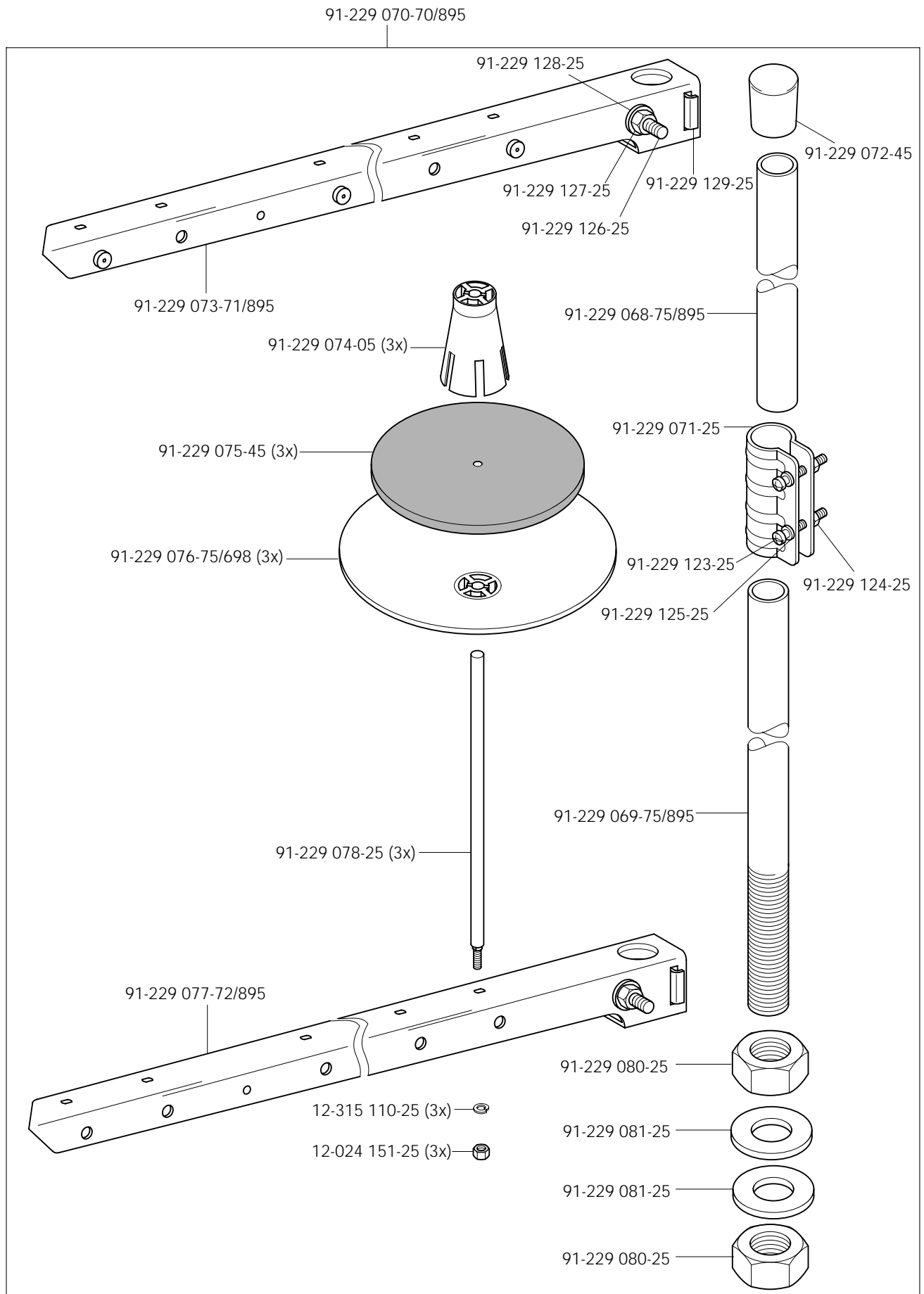

# 14

Einstellehren  
 Adjustment gauges  
 Calibres PFAFF 1525  
 Calibres de ajuste PFAFF 1526

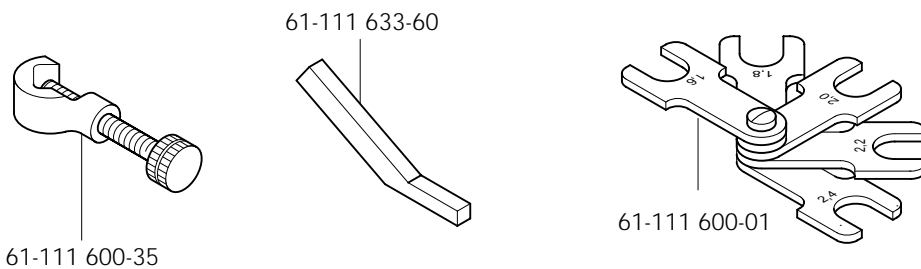

# 15

Teile zur Tischplatte  
 Parts for table top  
 Pièces du plateau PFAFF 1525  
 Piezas para el tablero PFAFF 1526

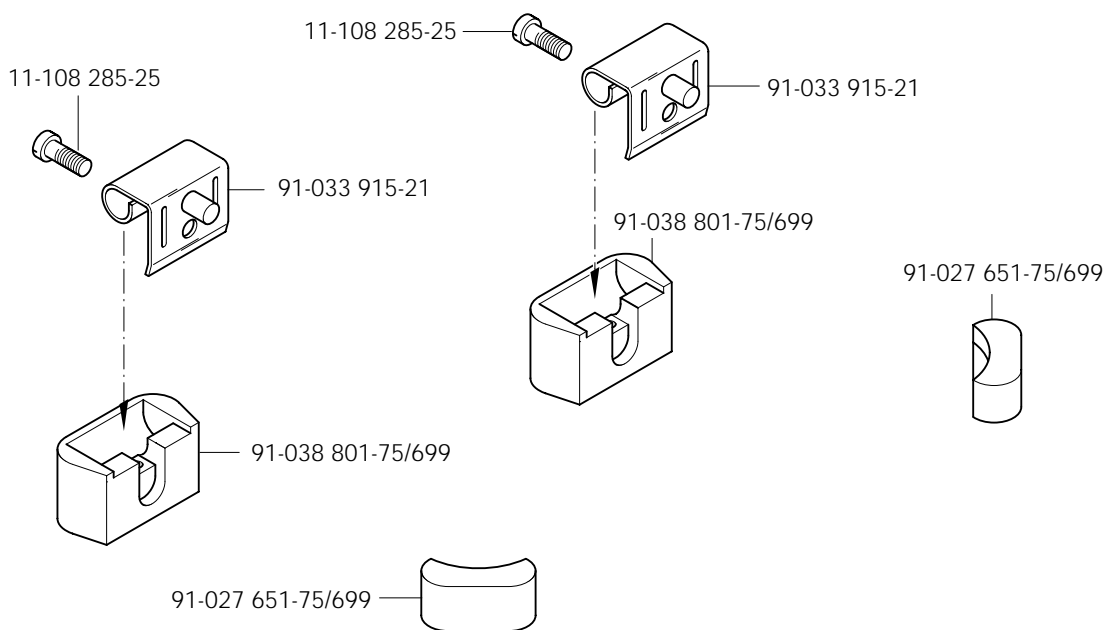

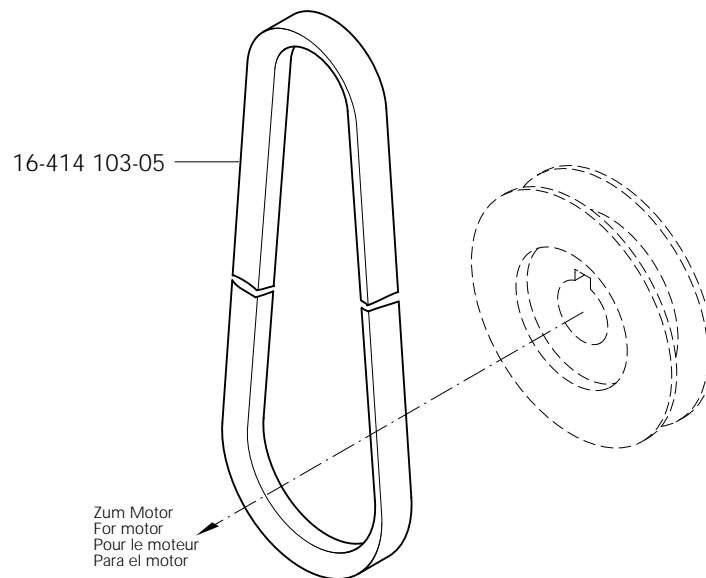

Öl Oil Huile Aceite	Mittelpunkts-Viskosität bei: Mean viscosity at: Viscosité moyenne à: Viscosidad media a:		Dichte bei: Density of: Densité à: Densidad a:		Bestellnummer für Behälter mit: Part number for can with: Numéro de commande pour récipients avec: Número de pedido para recipientes con:		
	°C	mm <sup>2</sup> /s	°C	g/cm <sup>3</sup> (g/ml)	1 Liter 1 Litre 1 Litro	5 Liter 5 Litre 5 Litros	10 Liter 10 Litre 10 Litros
28-011 201-44	40	22,0	15	0,865	91-129 917-91	91-129 919-91	91-129 920-91

Fett Grease Graisse Grasa	Penetration Penetration Pénétration Penetración	Tropfpunkt Drip-point Point de suintement Punto de goteo	Bestellnummer für Behälter mit: Part number for can with: Numéro de commande pour récipients avec: Número de pedido para recipientes con:				
			mm/10	°C	0,25 kg	0,5 kg	1 kg
28-011 202-05							28-011 202-05
28-011 202-43	375-405	150				28-011 202-43	
28-011 202-47	220-250	185					28-011 202-47

Reinigungsmittel Cleansing agent Agents de nettoyage Limpiadores	Bestellnummer für Behälter mit: Part number for can with: Numéro de commande pour récipients avec: Número de pedido para recipientes con:		
	240 ml		
Isopropyl-Alkohol	95-665 735-91		



No.	Seite Page Pages Página	No.	Seite Page Pages Página	No.	Seite Page Pages Página	No.	Seite Page Pages Página
11-039 096-15	4 - 4	11-130 191-15	3 - 11	11-210 168-25	3 - 7, 3 - 10	11-335 902-15	3 - 9, 3 - 21
11-039 222-15	4 - 4	11-130 197-15	11 - 1	11-210 174-15	3 - 17, 5 - 2	11-341 166-15	3 - 3, 3 - 13, 3 - 18, 3 - 19, 4 - 7, 5 - 3
11-039 225-15	3 - 6	11-130 224-15	3 - 9, 3 - 14, 3 - 22, 10 - 2, 10 - 3	11-210 210-15	3 - 18, 3 - 19, 4 - 7, 5 - 3	11-341 217-15	3 - 3
11-039 306-15	3 - 18, 3 - 19, 4 - 8, 5 - 3	11-130 227-25	4 - 4	11-210 295-15	3 - 9	11-341 280-15	4 - 4
11-108 090-15	3 - 11	11-130 233-15	3 - 1, 3 - 11, 3 - 22	11-225 175-15	3 - 21	11-341 901-15	3 - 20
11-108 132-15	4 - 4	11-130 239-15	3 - 1, 4 - 2	11-225 184-15	3 - 17, 5 - 2, 10 - 1	11-341 902-15	3 - 9, 3 - 22, 4 - 3
11-108 171-15	3 - 18, 3 - 19, 4 - 7, 5 - 3, 11 - 2, 12 - 2	11-130 245-15	4 - 6	11-225 220-15	3 - 1, 3 - 11	11-341 904-15	3 - 2, 3 - 3, 4 - 2, 6 - 1
11-108 171-25	3 - 14	11-130 254-15	6 - 1	11-225 223-15	4 - 3	11-341 905-15	3 - 9, 3 - 16, 3 - 18, 3 - 19, 4 - 5, 4 - 7, 5 - 1, 5 - 3
11-108 174-15	3 - 4, 3 - 5, 3 - 14, 3 - 18, 4 - 8, 10 - 2, 10 - 3	11-130 287-15	3 - 3, 3 - 18, 3 - 19, 4 - 7, 5 - 3, 6 - 1	11-225 304-15	3 - 13	11-347 301-15	3 - 13
11-108 180-15	12 - 4	11-130 293-15	3 - 2, 3 - 12, 3 - 21, 4 - 2, 4 - 4, 6 - 1, 10 - 2, 10 - 3	11-250 076-25	12 - 2	11-460 250-15	12 - 5
11-108 180-15	12 - 4			11-250 084-25	3 - 10	11-462 118-55	3 - 1
11-108 192-15	3 - 17	11-130 305-15	9 - 1	11-314 946-15	3 - 8	11-706 169-05	3 - 4, 3 - 5
11-108 207-25	3 - 15			11-317 949-15	3 - 5	11-713 010-91	3 - 11
11-108 219-15	4 - 8	11-130 311-15	3 - 19	11-317 950-15	3 - 18, 3 - 19, 4 - 7, 5 - 3	12-005 154-25	3 - 7, 3 - 8
11-108 222-25	4 - 1	11-130 906-15	3 - 1	11-330 082-15	3 - 5	12-005 171-15	3 - 18, 4 - 7, 5 - 3
11-108 225-25	3 - 1, 4 - 1	11-130 911-15	3 - 11	11-330 166-15	3 - 6, 4 - 5	12-005 175-15	3 - 11, 8 - 1
11-108 228-25	3 - 1	11-132 172-15	3 - 18, 3 - 19, 4 - 7, 5 - 3	11-330 169-15	3 - 7, 3 - 8	12-005 195-15	3 - 11, 3 - 12, 3 - 19
11-108 246-25	3 - 1	11-132 223-15	3 - 1, 3 - 12, 3 - 16, 5 - 1	11-330 172-15	4 - 6	12-024 121-15	4 - 4
11-108 255-25	4 - 1	11-132 292-15	3 - 3	11-330 175-15	3 - 18	12-024 121-25	10 - 3
11-108 258-25	3 - 1	11-132 298-15	4 - 5	11-330 217-15	3 - 18, 3 - 19, 4 - 7, 5 - 3	12-024 121-25	10 - 3
11-108 285-15	3 - 1, 3 - 18, 5 - 3	11-172 127-25	3 - 7, 3 - 8	11-330 220-15	3 - 6, 3 - 11	12-024 151-15	3 - 18, 10 - 2, 10 - 3
11-108 285-25	14 - 1	11-173 174-25	3 - 3	11-330 223-15	3 - 7, 3 - 22, 4 - 3, 4 - 5	12-024 151-25	13 - 1
11-108 846-15	3 - 3	11-174 082-15	3 - 4	11-330 280-15	3 - 9, 3 - 11, 3 - 22	12-024 171-15	3 - 19, 4 - 6, 7 - 1, 10 - 2, 10 - 3
11-130 089-15	3 - 2, 3 - 8	11-174 173-15	3 - 5	11-330 283-15	8 - 1	12-024 191-15	3 - 13, 3 - 19, 3 - 21, 6 - 1, 10 - 2, 10 - 3
11-130 092-15	3 - 17, 5 - 2, 10 - 1	11-178 233-25	3 - 11	11-330 952-15	3 - 10, 3 - 13, 3 - 21, 3 - 22, 4 - 3	12-024 191-25	3 - 10
11-130 095-15	3 - 18	11-180 169-25	3 - 1, 3 - 7, 3 - 8	11-330 960-15	3 - 3, 3 - 12, 3 - 18, 3 - 19, 3 - 21, 4 - 3, 4 - 4, 4 - 5, 4 - 7, 5 - 3, 6 - 1	12-024 951-15	4 - 5
11-130 108-15	4 - 3	11-186 934-25	3 - 7			12-090 150-05	3 - 11
11-130 113-15	3 - 7	11-210 038-15	3 - 16			12-305 084-25	3 - 8
11-130 167-15	3 - 18, 3 - 19, 4 - 7, 5 - 3	11-210 044-15	3 - 4	11-330 962-15	3 - 4	12-305 114-05	3 - 18, 4 - 7, 5 - 3
11-130 173-15	3 - 2, 3 - 18, 4 - 7, 5 - 3, 10 - 3, 11 - 2	11-210 078-15	3 - 17, 5 - 2	11-330 964-15	3 - 9, 3 - 18, 3 - 21, 3 - 22, 5 - 3	12-305 114-15	3 - 18
11-130 176-15	3 - 19, 3 - 22, 4 - 4, 4 - 5	11-210 084-25	10 - 3	11-335 280-15	3 - 3, 3 - 9, 3 - 22	12-305 174-15	3 - 11, 3 - 12, 3 - 21
		11-210 168-15	3 - 21				

No.	Seite Page Pages Página	No.	Seite Page Pages Página	No.	Seite Page Pages Página	No.	Seite Page Pages Página
12-315 080-15	3 - 17, 3 - 18, 5 - 2, 10 - 1	12-710 270-12	3 - 3	18-372 004-91	9 - 1	71-140 000-41	12 - 4
12-315 090-25	3 - 7, 3 - 8	12-710 904-12	3 - 13	18-372 008-91	10 - 2, 10 - 3	71-370 001-32	3 - 4, 3 - 5, 12 - 2
12-315 110-15	3 - 11	13-030 998-05	3 - 22	18-373 011-91	10 - 2, 10 - 3	71-370 001-33	11 - 2
12-315 110-25	13 - 1	13-033 004-05	3 - 17, 5 - 2	18-378 002-91	10 - 2, 10 - 3	71-370 001-44	3 - 18, 5 - 3
12-315 140-15	4 - 4	13-033 091-05	3 - 7	18-378 008-91	3 - 18, 4 - 3, 4 - 7, 4 - 8, 5 - 3, 8 - 1	71-370 002-91	12 - 5
12-335 191-15	10 - 2, 10 - 3	13-033 109-05	3 - 7, 3 - 8	18-378 009-91	6 - 1	71-370 002-92	12 - 5
12-341 090-25	3 - 13	13-033 208-05	3 - 13	25-135 800-27	10 - 1	71-370 003-09	12 - 5
12-360 061-05	3 - 18, 4 - 7, 5 - 3	13-052 046-55	3 - 16	25-161 801-49	3 - 15	71-590 006-94	12 - 4
12-360 084-05	3 - 22	13-060 902-05	4 - 4, 4 - 5	25-161 801-52	3 - 15, 4 - 4	71-590 007-12	12 - 3
12-360 113-05	3 - 13	13-060 904-05	4 - 5	25-308 820-25	11 - 1	71-630 003-08	3 - 1, 12 - 1
12-360 184-15	3 - 11	13-064 262-05	3 - 13	25-308 820-30	7 - 1, 8 - 1, 11 - 1, 11 - 2	71-850 000-91	10 - 2, 10 - 3
12-361 156-15	3 - 9	13-064 388-05	3 - 11, 3 - 13	25-308 820-40	4 - 8, 9 - 1, 10 - 2, 10 - 3, 11 - 1, 11 - 2	91-000 390-05	3 - 16, 5 - 1
12-499 150-45	10 - 2, 10 - 3	13-068 187-05	4 - 4	25-308 820-60	9 - 1, 10 - 2, 10 - 3, 11 - 2	91-000 529-15	3 - 16, 5 - 1
12-499 170-45	7 - 1	13-250 094-25	3 - 13	26-534 300-50	4 - 2	91-000 928-15	3 - 16, 5 - 1
12-499 190-45	9 - 1	14-016 151-91	3 - 18, 5 - 3	26-536 302-09	4 - 4	91-002 065-05	3 - 7, 3 - 8
12-505 190-45	3 - 7	14-018 644-91	3 - 9	28-011 201-44	17 - 1	91-002 262-25	3 - 7, 3 - 8
12-510 171-45	3 - 12	14-218 090-01	3 - 3	28-011 202-05	17 - 1	91-010 183-05	3 - 7, 3 - 8
12-610 150-45	4 - 4	14-218 100-01	3 - 13	28-011 202-43	17 - 1	91-010 215-05	3 - 7, 3 - 8
12-610 170-45	3 - 2, 3 - 16, 4 - 2, 5 - 1	14-218 200-91	3 - 13	28-011 202-47	17 - 1	91-011 374-05	3 - 13
12-610 200-45	3 - 16, 5 - 1	14-602 901-01	3 - 10	61-000 600-01	14 - 1	91-011 391-05	4 - 1
12-610 210-45	3 - 6, 11 - 2	14-650 251-05	3 - 21	61-111 600-35	14 - 1	91-018 293-05	3 - 16, 5 - 1
12-610 250-45	3 - 13	15-032 001-45	6 - 1, 10 - 2, 10 - 3	61-111 633-60	14 - 1	91-018 439-05	5 - 1
12-610 280-45	3 - 20	15-032 002-45	9 - 1	71-120 006-31	3 - 11	91-018 872-05	5 - 1
12-610 310-45	3 - 4, 3 - 5	15-120 707-05	3 - 16	71-130 005-95	12 - 2	91-020 086-15	3 - 18, 3 - 19, 4 - 8, 5 - 3
12-610 330-45	3 - 11	15-120 902-05	3 - 16	71-130 005-96	12 - 2	91-027 651-75/699	14 - 1
12-610 370-45	8 - 1	15-120 916-05	3 - 17, 5 - 2	71-130 005-97	12 - 2	91-027 846-75/698	3 - 1
12-624 250-45	3 - 13	15-125 049-05	4 - 8	71-130 005-98	12 - 2	91-027 918-91	11 - 2
12-624 310-45	3 - 13	15-718 051-51	3 - 3, 4 - 5	71-130 005-99	12 - 2	91-029 741-15	4 - 4
12-640 130-05	8 - 1	16-040 010-11	3 - 18, 4 - 7, 5 - 3	71-130 006-01	12 - 2	91-033 765-15	3 - 21
12-640 130-55	3 - 7, 3 - 8, 3 - 10, 3 - 18, 4 - 7, 5 - 3, 7 - 1	16-409 978-05	3 - 9	71-130 006-02	12 - 2	91-033 915-21	14 - 1
12-640 150-55	3 - 8, 6 - 1, 7 - 1, 8 - 1	16-414 103-05	16 - 1	71-130 006-23	12 - 2	91-038 801-75/699	14 - 1
		18-372 003-91	9 - 1			91-056 192-25	3 - 7, 3 - 8, 3 - 10

No.	Seite Page Pages Página	No.	Seite Page Pages Página	No.	Seite Page Pages Página	No.	Seite Page Pages Página
91-056 193-25	3 - 7, 3 - 8, 3 - 10	91-118 704-05	3 - 18, 3 - 19, 4 - 7, 5 - 3	91-140 676-05	3 - 17, 5 - 2	91-166 485-01	3 - 2, 4 - 2
91-056 351-05	10 - 3	91-118 707-92	3 - 18, 3 - 19, 4 - 7, 5 - 3	91-140 945-05	3 - 16, 5 - 1	91-166 487-05	3 - 2, 4 - 2
91-056 578-91	3 - 10	91-118 708-15	3 - 18	91-162 526-05	3 - 21	91-166 488-01	4 - 2
91-056 760-05	3 - 7, 3 - 8	91-118 709-15	3 - 19, 4 - 7	91-163 088-75/698	3 - 13	91-166 491-01	4 - 2
91-069 062-05	3 - 2, 4 - 2	91-118 711-05	3 - 16, 3 - 17, 5 - 1, 5 - 2	91-164 902-01	3 - 6	91-166 507-91	3 - 3
91-089 467-05	7 - 1	91-118 712-91	3 - 18, 5 - 3	91-164 946-71/893	10 - 2	91-166 510-05	3 - 3
91-090 988-91	10 - 2, 10 - 3	91-118 713-01	3 - 18, 5 - 3	91-165 887-91	6 - 1	91-166 511-92	3 - 3
91-091 606-91	12 - 5	91-118 724-12	3 - 18, 5 - 3	91-166 067-15	4 - 5	91-166 515-05	4 - 2
91-100 270-25	3 - 13	91-118 787-15	3 - 17, 5 - 2	91-166 085-05	4 - 6	91-166 518-15	3 - 2
91-100 281-25	3 - 10	91-118 880-91	3 - 14	91-166 148-72/951	3 - 21	91-166 522-91	4 - 3
91-100 355-05	3 - 5	91-118 882-92	3 - 14	91-166 185-05	3 - 13	91-166 524-91	3 - 3
91-100 396-05	5 - 1	91-118 886-92	3 - 14	91-166 187-02	3 - 13	91-166 529-05	3 - 3
91-100 396-15	3 - 16	91-118 888-05	3 - 14	91-166 352-05	3 - 18, 4 - 7, 5 - 3	91-166 531-05	4 - 2
91-105 447-25	3 - 7, 3 - 8	91-118 893-92	3 - 20	91-166 376-91	3 - 16	91-166 532-05	3 - 11, 4 - 2
91-105 482-05	3 - 13	91-118 894-05	3 - 20	91-166 378-05	3 - 16	91-166 533-05	3 - 11, 4 - 2
91-113 023-92	3 - 8	91-118 901-12	3 - 21	91-166 381-05	3 - 17, 5 - 2	91-166 542-05	3 - 11
91-113 027-15	3 - 8	91-118 940-05	3 - 10	91-166 382-05	3 - 17	91-166 543-05	3 - 11
91-113 445-15	7 - 1, 8 - 1	91-119 015-15	3 - 4, 3 - 5	91-166 383-15	3 - 17	91-166 545-05	8 - 1
91-118 044-91	3 - 14	91-119 085-05	3 - 20	91-166 384-05	3 - 17	91-166 549-75/895	4 - 6
91-118 045-91	3 - 14	91-119 269-91	3 - 22	91-166 388-05	3 - 16	91-166 550-15	3 - 2
91-118 067-25	3 - 14	91-119 704-91	3 - 9	91-166 391-15	3 - 16	91-166 559-25	3 - 7
91-118 099-91	3 - 10	91-119 763-05	3 - 6	91-166 393-01	3 - 2	91-166 571-72/895	4 - 1
91-118 154-90	3 - 18, 3 - 19, 4 - 7, 5 - 3	91-125 933-05	6 - 1	91-166 394-71/951	3 - 21	91-166 587-15	3 - 11
91-118 178-07	3 - 20	91-129 917-91	17 - 1	91-166 452-21	3 - 10	91-166 593-01	4 - 2
91-118 196-12	3 - 5	91-129 919-91	17 - 1	91-166 464-71/895	4 - 4	91-166 638-25	4 - 1
91-118 430-25	3 - 7	91-129 920-91	17 - 1	91-166 466-72/895	4 - 4	91-166 670-15	12 - 4
91-118 518-05	3 - 6	91-140 199-02	3 - 16, 5 - 1	91-166 470-75/895	4 - 1	91-166 708-90	12 - 4
91-118 570-92	3 - 9	91-140 239-05	3 - 17, 5 - 2	91-166 471-75/895	4 - 1	91-166 717-15	3 - 1
91-118 681-05	3 - 10	91-140 372-05	3 - 2	91-166 472-91	4 - 3	91-166 807-15	6 - 1
91-118 683-05	3 - 10	91-140 452-05	5 - 1	91-166 475-91	4 - 5	91-166 824-05	3 - 5
91-118 685-05	3 - 10	91-140 453-05	5 - 1	91-166 479-91	4 - 2	91-166 827-05	3 - 16
91-118 703-01	3 - 18, 3 - 19, 4 - 7, 5 - 3	91-140 552-91	5 - 1	91-166 480-92	3 - 2, 4 - 2	91-166 828-05	3 - 16

No.	Seite Page Pages Página	No.	Seite Page Pages Página	No.	Seite Page Pages Página	No.	Seite Page Pages Página
91-166 836-05	12 - 2	91-173 988-05	4 - 7	91-176 327-25	3 - 8	91-229 076-75/698	13 - 1
91-166 853-91	7 - 1	91-174 155-12	3 - 18, 3 - 19, 4 - 7, 5 - 3	91-176 329-05	3 - 7, 3 - 8	91-229 077-72/895	13 - 1
91-166 879-91	11 - 2	91-174 303-15	3 - 4, 3 - 5	91-176 337-15	3 - 7	91-229 078-25	13 - 1
91-166 949-92	3 - 11	91-174 344-92	3 - 9	91-176 340-91	5 - 1	91-229 080-25	13 - 1
91-166 997-01	3 - 2	91-174 783-05	3 - 10	91-176 360-05	3 - 12	91-229 081-25	13 - 1
91-167 568-05	3 - 11	91-174 879-05	3 - 10	91-176 373-21	3 - 7, 3 - 8	91-229 123-25	13 - 1
91-168 055-91	3 - 9	91-175 648-15	4 - 4	91-176 377-25	3 - 8	91-229 124-25	13 - 1
91-168 194-71/698	3 - 7, 3 - 8	91-175 649-15	4 - 4	91-176 378-05	3 - 7, 3 - 8	91-229 125-25	13 - 1
91-168 480-15	3 - 9	91-175 908-05	3 - 16	91-176 438-05	3 - 16, 5 - 1	91-229 126-25	13 - 1
91-169 132-15	3 - 21	91-176 063-15	7 - 1	91-176 462-05	3 - 8	91-229 127-25	13 - 1
91-170 809-15	4 - 3	91-176 076-91	3 - 18, 3 - 19, 4 - 7, 5 - 3	91-176 464-05	3 - 7, 3 - 8	91-229 128-25	13 - 1
91-171 042-05	3 - 10	91-176 094-05	3 - 18, 3 - 19, 4 - 7, 5 - 3	91-176 482-91	3 - 6	91-229 129-25	13 - 1
91-171 049-05	3 - 10	91-176 103-91	3 - 19	91-177 097-92	4 - 1	91-262 195-92	3 - 9
91-171 175-05	6 - 1	91-176 177-91	3 - 9	91-177 464-75/893	10 - 2, 10 - 3	91-262 197-05	3 - 13
91-171 175-12	3 - 21	91-176 178-05	3 - 2, 4 - 2	91-177 609-05	3 - 2	91-262 202-15	3 - 13
91-171 774-15	11 - 1	91-176 180-05	4 - 2	91-177 610-05	3 - 2	91-262 203-05	3 - 13
91-171 808-05	3 - 2	91-176 188-05	4 - 2	91-177 918-15	4 - 4	91-266 104-75/698	3 - 1
91-171 875-12	3 - 3	91-176 192-05	3 - 2, 4 - 2	91-177 920-91	4 - 4	91-266 105-75/698	3 - 1
91-173 072-05	3 - 22	91-176 199-92	3 - 4, 3 - 5	91-177 921-15	4 - 4	91-266 106-75/699	3 - 1
91-173 073-05	3 - 22	91-176 204-05	3 - 4, 3 - 5	91-186 659-05	3 - 17, 5 - 2, 10 - 1	91-266 114-15	3 - 1
91-173 082-72/951	3 - 22	91-176 207-91	3 - 9	91-187 386-75/893	9 - 1	91-266 117-72/893	3 - 9
91-173 139-15	7 - 1, 8 - 1	91-176 267-05	3 - 2	91-187 426-70/893	9 - 1	91-266 129-05	3 - 16
91-173 185-05	3 - 18, 5 - 3	91-176 288-05	5 - 1	91-188 163-15	3 - 17, 5 - 2, 10 - 1	91-266 132-05	3 - 16
91-173 538-15	3 - 19	91-176 289-05	5 - 1	91-188 539-02	3 - 17, 5 - 2	91-266 136-05	3 - 16
91-173 539-15	3 - 19	91-176 290-05	5 - 1	91-229 068-75/895	13 - 1	91-266 172-05	3 - 2
91-173 572-05	3 - 17, 5 - 2	91-176 302-05	3 - 6	91-229 069-75/895	13 - 1	91-266 173-05	3 - 2
91-173 664-15	4 - 1	91-176 309-05	3 - 5	91-229 070-70/895	13 - 1	91-266 236-15	3 - 19
91-173 769-05	4 - 4	91-176 315-05	3 - 6	91-229 071-25	13 - 1	91-266 241-05	10 - 1
91-173 770-05	4 - 4	91-176 321-05	3 - 8	91-229 072-45	13 - 1	91-266 258-91	3 - 2
91-173 911-05	3 - 17, 5 - 2	91-176 323-05	3 - 8	91-229 073-71/895	13 - 1	91-266 277-01	3 - 2
91-173 915-92	3 - 16, 5 - 1	91-176 324-25	3 - 7, 3 - 8	91-229 074-05	13 - 1	91-266 288-15	3 - 18, 3 - 19, 5 - 3
91-173 973-15	3 - 16, 5 - 1	91-176 326-05	3 - 8	91-229 075-45	13 - 1		

No.	Seite Page Pages Página	No.	Seite Page Pages Página	No.	Seite Page Pages Página	No.	Seite Page Pages Página
91-266 289-72/951	3 - 19	91-266 447-71/698	3 - 8	91-266 579-91	3 - 18	91-266 697-05	6 - 1
91-266 298-05	3 - 17, 5 - 2, 10 - 1	91-266 448-12	3 - 18, 5 - 3	91-266 584-05	3 - 17, 10 - 1	91-266 700-92	6 - 1
91-266 299-91	3 - 17, 5 - 2, 10 - 1	91-266 463-71/698	3 - 8	91-266 585-01	3 - 17, 10 - 1	91-266 701-91	3 - 22
91-266 306-91	10 - 1	91-266 465-71/698	3 - 7	91-266 588-05	3 - 18	91-266 706-25	3 - 14
91-266 313-90	10 - 1	91-266 479-91	3 - 21	91-266 589-05	3 - 18	91-266 707-75/698	3 - 13
91-266 316-91	3 - 17, 5 - 2	91-266 481-05	3 - 22	91-266 593-92	3 - 16	91-266 710-71/698	3 - 11
91-266 325-05	3 - 2, 4 - 2	91-266 482-05	3 - 21	91-266 595-71/895	3 - 15	91-266 711-05	3 - 11
91-266 326-05	3 - 2, 4 - 2	91-266 483-05	3 - 21	91-266 601-75/895	3 - 1	91-266 712-05	3 - 11
91-266 332-91	3 - 5	91-266 484-05	3 - 21	91-266 602-75/895	3 - 1	91-266 713-05	3 - 11
91-266 334-05	3 - 2	91-266 486-15	3 - 11	91-266 603-15	4 - 8	91-266 714-75/893	3 - 11
91-266 335-01	3 - 4, 3 - 5	91-266 490-90	7 - 1	91-266 605-05	3 - 17, 5 - 2	91-266 715-91	3 - 11
91-266 347-15	3 - 1	91-266 496-92	3 - 19	91-266 606-91	3 - 17, 5 - 2	91-266 716-05	3 - 11
91-266 352-75/895	3 - 1	91-266 498-05	4 - 4	91-266 608-91	4 - 8	91-266 717-05	3 - 11
91-266 358-15	3 - 1	91-266 504-91	3 - 16	91-266 651-05	3 - 4	91-266 718-91	8 - 1
91-266 359-05	3 - 17, 5 - 2	91-266 505-91	3 - 16	91-266 652-00	3 - 17, 5 - 2	91-266 719-15	8 - 1
91-266 381-05	3 - 18, 3 - 19, 4 - 7, 5 - 3	91-266 514-91	3 - 11	91-266 661-91	3 - 16	91-266 720-05	3 - 11
91-266 383-91	3 - 6	91-266 520-92	3 - 22	91-266 665-91	8 - 1	91-266 728-15	4 - 1
91-266 385-91	3 - 19	91-266 521-71/895	3 - 13	91-266 666-05	3 - 13	91-266 729-04/004	3 - 11
91-266 397-01	3 - 10	91-266 522-75/895	3 - 13	91-266 669-05	3 - 18	91-266 730-05	3 - 13
91-266 400-05	3 - 2	91-266 523-75/698	3 - 13	91-266 671-05	3 - 18	91-266 738-05	3 - 7
91-266 410-25	3 - 7, 3 - 8	91-266 524-12	3 - 13	91-266 672-05	3 - 18	91-266 753-45	4 - 6
91-266 411-25	3 - 7, 3 - 8	91-266 525-12	3 - 13	91-266 673-12	3 - 18	91-266 757-05	3 - 7
91-266 414-05	3 - 7, 3 - 8	91-266 528-05	3 - 13	91-266 675-92	6 - 1	91-266 782-15	3 - 1
91-266 416-92	3 - 12	91-266 529-11	3 - 13	91-266 676-05	6 - 1	91-266 783-91	3 - 4
91-266 417-92	3 - 12	91-266 532-12	3 - 13	91-266 678-72/895	4 - 1	91-266 784-24/001	3 - 14
91-266 424-91	3 - 18, 4 - 7, 5 - 3	91-266 533-05	3 - 13	91-266 679-91	6 - 1	91-266 784-24/002	3 - 14
91-266 428-01	3 - 18, 4 - 7, 5 - 3	91-266 537-71/698	3 - 13	91-266 681-91	3 - 16	91-266 786-91	5 - 1
91-266 432-91	3 - 12	91-266 538-71/698	3 - 13	91-266 683-91	3 - 16	91-266 787-91	5 - 1
91-266 436-91	3 - 7	91-266 539-71/698	3 - 13	91-266 684-05	3 - 16	91-266 796-15	3 - 11
91-266 438-25	3 - 7	91-266 540-91	3 - 7	91-266 685-91	3 - 16	91-266 826-91	3 - 3
91-266 440-71/698	3 - 7	91-266 541-91	3 - 4	91-266 688-90	10 - 1	91-266 827-91	3 - 3
91-266 445-91	3 - 8	91-266 559-45	11 - 1	91-266 694-05	3 - 18	91-266 828-91	3 - 6

No.	Seite Page Pages Página	No.	Seite Page Pages Página	No.	Seite Page Pages Página	No.	Seite Page Pages Página
91-266 829-91	3 - 12	91-266 929-93/001	3 - 14	99-134 256-91	11 - 1, 11 - 2	99-137 223-91	11 - 1
91-266 830-91	3 - 16	91-266 929-93/002	3 - 14	99-134 299-91	3 - 18, 4 - 6, 4 - 7, 5 - 3	99-137 272-05	4 - 8
91-266 831-91	3 - 17	91-266 929-93/003	3 - 14	99-134 369-91	10 - 2, 10 - 3	99-137 285-91	3 - 18, 5 - 3
91-266 832-91	3 - 20	91-266 929-93/004	3 - 14	99-134 370-91	11 - 2	99-137 286-91	6 - 1
91-266 833-91	3 - 21	91-266 929-93/005	3 - 14	99-134 421-91	3 - 18, 4 - 7, 5 - 3		
91-266 834-91	3 - 22	91-266 929-93/006	3 - 14	99-134 437-15	11 - 2		
91-266 835-91	4 - 4	91-266 929-93/007	3 - 14	99-134 452-91	10 - 2, 10 - 3		
91-266 836-91	4 - 4	91-266 929-93/008	3 - 14	99-134 621-01	10 - 2, 10 - 3		
91-266 837-91	4 - 7	91-266 929-93/009	3 - 14	99-134 850-91	10 - 2, 10 - 3		
91-266 838-91	3 - 6	91-266 929-93/010	3 - 14	99-135 001-95	11 - 1, 11 - 2		
91-266 839-91	3 - 6	91-266 931-71/698	3 - 1	99-135 002-95	7 - 1, 10 - 1, 11 - 1		
91-266 873-91	3 - 22	91-290 495-91	10 - 3	99-135 233-91	3 - 18, 4 - 6		
91-266 880-93/001	3 - 14	91-290 577-91	10 - 2, 10 - 3	99-135 353-91	4 - 4		
91-266 882-05	3 - 14, 4 - 1	91-290 659-71/895	10 - 3	99-135 496-95	3 - 15, 4 - 4		
91-266 883-71/698	3 - 1	91-291 133-91	3 - 7	99-135 617-95	4 - 8		
91-266 890-71/893	10 - 3	91-291 442-91	12 - 5	99-135 835-05	11 - 1		
91-266 894-04	4 - 6	91-291 560-71/699	12 - 2	99-135 890-91	4 - 6		
91-266 895-91	4 - 3	91-291 639-91	12 - 1	99-136 031-91	4 - 3		
91-266 896-01	4 - 3	91-291 806-91	12 - 2	99-136 071-95	11 - 1		
91-266 899-05	4 - 3	91-700 173-15	3 - 14	99-136 072-95	4 - 8, 11 - 1		
91-266 904-91	4 - 1	91-700 249-15	3 - 17, 5 - 2, 10 - 1	99-136 310-05	11 - 2		
91-266 906-05	3 - 16, 5 - 1	91-700 412-25	3 - 7, 3 - 11	99-136 328-91	7 - 1		
91-266 927-93/001	3 - 14	91-700 510-15	3 - 9, 3 - 21	99-136 336-95	12 - 4		
91-266 927-93/002	3 - 14	91-700 689-15	3 - 9, 3 - 14	99-136 396-91	3 - 18, 3 - 19, 4 - 7, 5 - 3		
91-266 927-93/003	3 - 14	91-701 522-25	3 - 7	99-136 409-91	4 - 8		
91-266 927-93/004	3 - 14	95-215 000-04/847	6 - 1	99-136 486-91	8 - 1		
91-266 927-93/005	3 - 14	95-665 735-91	17 - 1	99-136 546-91	9 - 1		
91-266 927-93/006	3 - 14	95-780 087-75/895	10 - 3	99-136 757-05	11 - 2		
91-266 927-93/007	3 - 14	96-100 580-48	12 - 4	99-136 771-15	11 - 2		
91-266 927-93/008	3 - 14	96-721 197-92	4 - 3	99-136 778-91	3 - 10		
91-266 927-93/009	3 - 14	99-115 425-91	3 - 18	99-137 017-01	11 - 2		
91-266 927-93/010	3 - 14	99-134 206-05	10 - 2, 10 - 3	99-137 151-45	3 - 10		

# PFAFF

1525

1526

Unterklassen-Ausstattung

Subclass parts

Composition des sous-classes

Composición de las subclases

## -2/04-900/81;/82 BN8♦

Für rechte Kantennäharbeiten.  
Standardform des Teilesatzes.  
Lineal auf hochklappbar.

For right-hand marginal stitching  
operations.  
Standard part set.  
Swing-up edge guide.

Piqûres longeant les bords.  
Jeu de pièces standard.  
Guide relevable.

Para el cosido de orillas o cantos.  
Juego de piezas estándar.  
Guía evadiza.

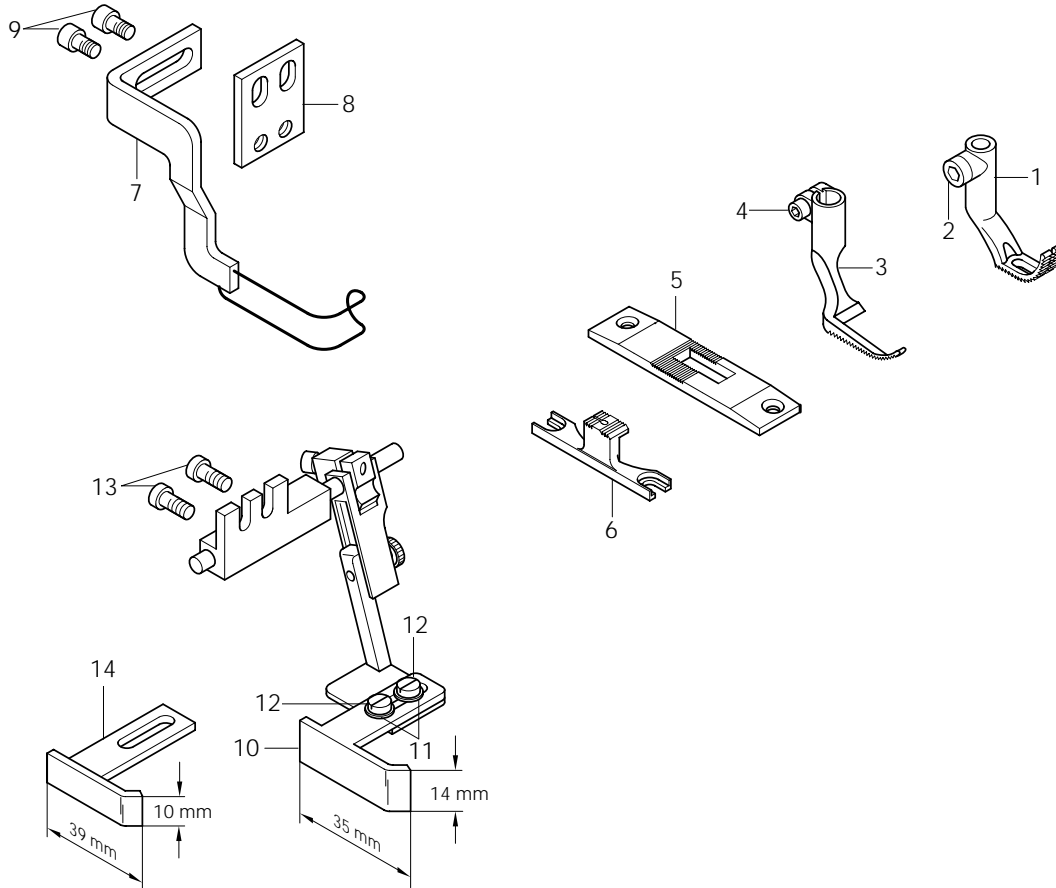

Pos.-Nr. Item No. N° pos. N° de pos.	Absteppbreite Stitching margin Relarge de couture Margen de costura	Teile-Nr. Part No. N° de piezas N° de pieza
1 - 2	1,5 4,0	91-049 394-93/005 91-049 394-93/004
2		11-132 217-15
3 - 4	1,5 4,0	91-149 170-93/001 91-149 170-93/006
4		11-130 173-15
5	1,5 4,0	91-150 608-04/001 91-150 608-04/006
6	1,5 4,0	91-059 936-04/001 91-059 936-04/005
7 - 9		91-155 426-91

Pos.-Nr. Item No. N° pos. N° de pos.	Absteppbreite Stitching margin Relarge de couture Margen de costura	Teile-Nr. Part No. N° de piezas N° de pieza
7		91-155 427-91
8		91-057 698-15
9		11-130 167-15
10 - 13		09-009 824-22
10		99-117 869-23
11		91-100 120-25
12		12-305 114-25
13		11-132 223-15
14		99-117 868-23



-2/04-900/81;/82 CN8<sup>♦</sup>

Für rechte Kantennäharbeiten.  
Standardform des Teilesatzes.  
Lineal auf hochklappbar.

For right-hand marginal stitching operations.  
Standard part set.  
Swing-up edge guide.

Piqûres longeant les bords.  
Jeu de pièces standard.  
Guide relavable.

Para el cosido de orillas o cantos.  
Juego de piezas estándar.  
Guía evadiza.

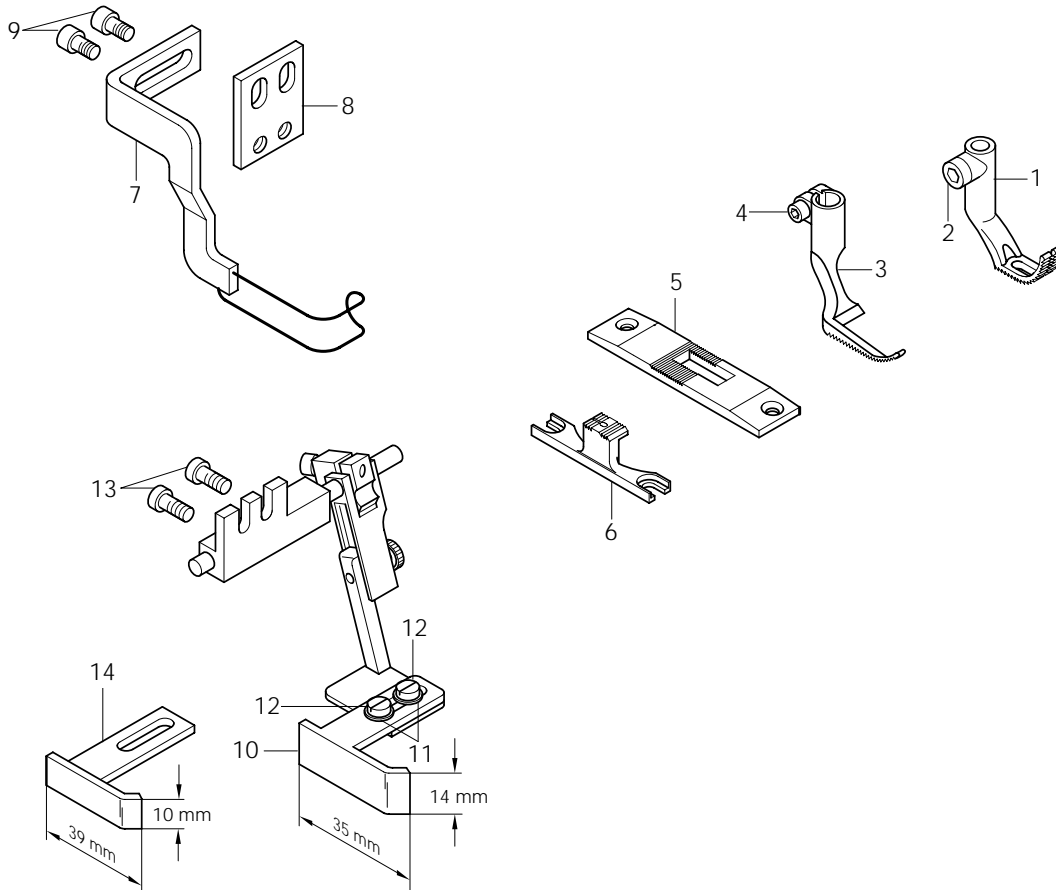

Pos.-Nr. Item No. N° pos. N° de pos.	Absteppbreite Stitching margin Relarge de couture Margen de costura	Teile-Nr. Part No. N° de piezas N° de pieza
1 - 13	2,5	91-201 788-93/001
1 - 2	2,5 4,0	91-049 394-93/012 91-049 394-93/003
2		11-132 217-15
3 - 4	2,5 4,0	91-149 170-93/011 91-149 170-93/014
4		11-130 173-15
5	2,5 4,0	91-150 608-04/009 91-150 608-04/012
6	2,5 4,0	91-059 936-04/009 91-059 936-04/012

Pos.-Nr. Item No. N° pos. N° de pos.	Absteppbreite Stitching margin Relarge de couture Margen de costura	Teile-Nr. Part No. N° de piezas N° de pieza
7 - 9		91-155 426-91
7		91-155 427-91
8		91-057 698-15
9		11-130 167-15
10 - 13		09-009 824-22
10		99-117 869-23
11		91-100 120-25
12		12-305 114-25
13		11-132 223-15
14		99-117 868-23

## -3/04-900/81;/82 BN8♦

Für linke Kantennäharbeiten.  
Standardform des Teilesatzes.  
Fußpaar gezahnt.

For reworking left-hand edges.  
Standard part set.  
Toothed feet pair.

Pour les coutures au bord gauche.  
Jeu de pièces standard.  
Semelles des pieds crantées.

Para costuras marginales a la izquierda.  
Juego de piezas estándar.  
Par de pies prensatelas dentados.

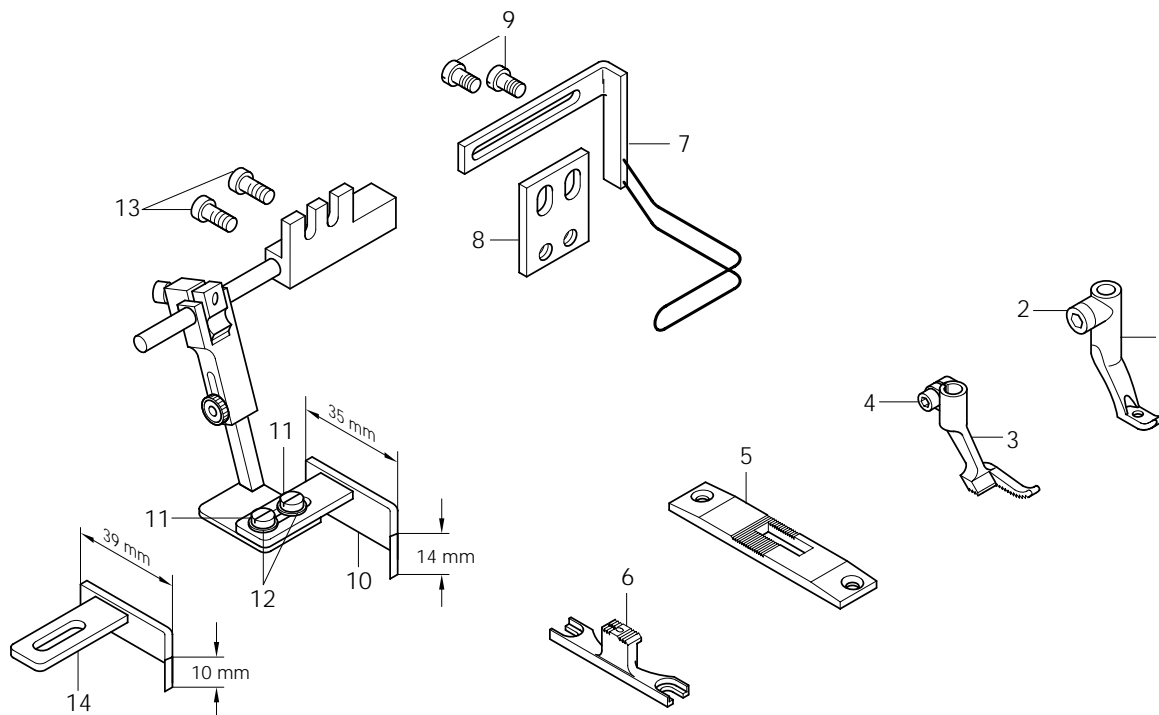

Pos.-Nr. Item No. N° pos. N° de pos.	Absteppbreite Stitching margin Relarge de couture Margen de costura	Teile-Nr. Part No. N° de piezas N° de pieza	Pos.-Nr. Item No. N° pos. N° de pos.	Absteppbreite Stitching margin Relarge de couture Margen de costura	Teile-Nr. Part No. N° de piezas N° de pieza
1 - 2	1,5 2,0 2,5 3,0 3,5 4,0	91-049 408-93/002 91-049 408-93/003 91-049 408-93/005 91-049 408-93/006 91-049 408-93/006 91-049 408-93/008	6	1,5 2,0 2,5 3,0 3,5 4,0	91-059 941-04/001 91-059 941-04/002 91-059 941-04/003 91-059 941-04/004 91-059 941-04/005 91-059 941-04/006
2		11-132 217-15	7 - 9		91-154 625-91
3 - 4	1,5 2,0 2,5 3,0 3,5 4,0	91-149 172-93/001 91-149 172-93/002 91-149 172-93/003 91-149 172-93/004 91-149 172-93/005 91-149 172-93/006	7		91-057 714-91
4		11-130 173-15	8		91-057 698-15
5	1,5 2,0 2,5 3,0 3,5 4,0	91-150 618-04/001 91-150 618-04/002 91-150 618-04/003 91-150 618-04/004 91-150 618-04/005 91-150 618-04/006	9		11-108 168-15
			10 - 13		09-009 844-35
			10		99-117 869-23
			11		91-100 120-25
			12		12-305 114-25
			13		11-132 223-15
			14		99-117 868-23

-3/04-900/81;/82 CN8♦

Für linke Kantennäharbeiten.  
 Standardform des Teilesatzes.  
 Fußpaar gezahnt.

For reworking left-hand edges.  
 Standard part set.  
 Toothed feet pair.

Pour les coutures au bord gauche.  
 Jeu de pièces standard.  
 Semelles des pieds crantées.

Para costuras marginales a la izquierda.  
 Juego de piezas estándar.  
 Par de pies prensatelas dentados.

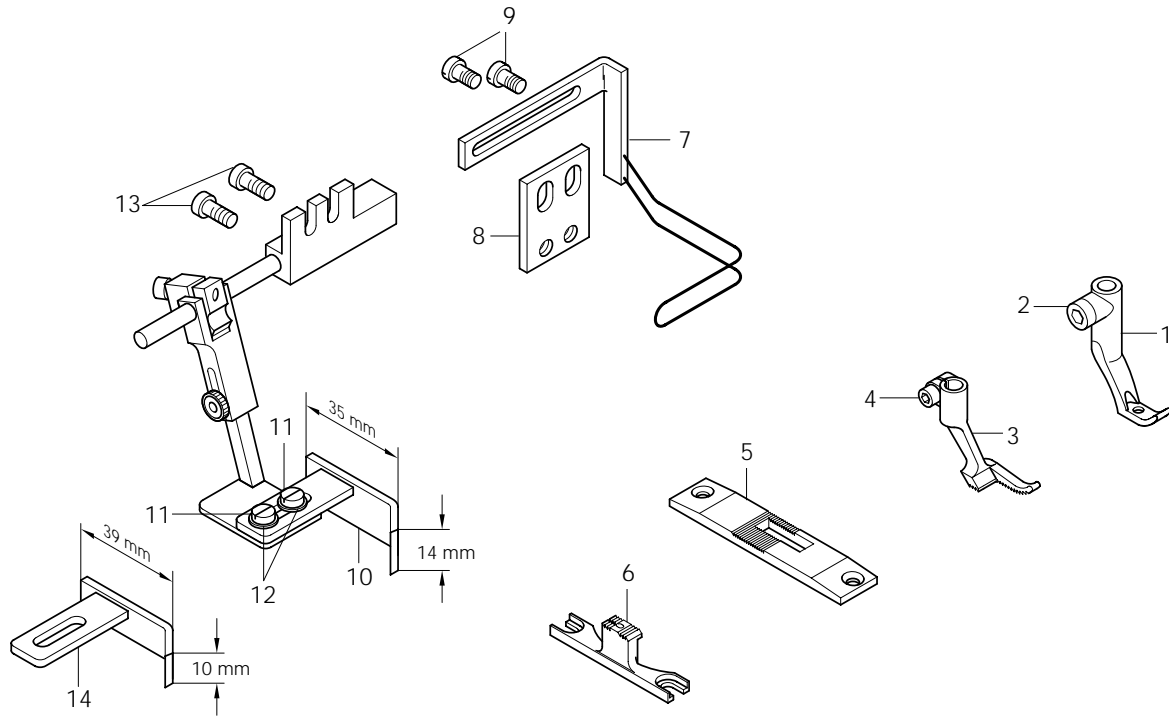

Pos.-Nr. Item No. N° pos. N° de pos.	Absteppbreite Stitching margin Relarge de couture Margen de costura	Teile-Nr. Part No. N° de piezas N° de pieza
1 - 13	3,0	91-201 792-93/001
1 - 2	2,5 3,0 3,5 4,0 5,0	91-049 408-93/007 91-049 408-93/007 91-049 408-93/001 91-049 408-93/001 91-049 408-93/011
2		11-132 217-15
3 - 4	2,5 3,0 3,5 4,0 5,0	91-149 172-93/009 91-149 172-93/010 91-149 172-93/011 91-149 172-93/012 91-149 172-93/014
4		11-130 173-15
5	2,5 3,0 3,5 4,0 5,0	91-150 618-04/015 91-150 618-04/010 91-150 618-04/011 91-150 618-04/012 91-150 618-04/012

Pos.-Nr. Item No. N° pos. N° de pos.	Absteppbreite Stitching margin Relarge de couture Margen de costura	Teile-Nr. Part No. N° de piezas N° de pieza
6	2,5 3,0 3,5 4,0 5,0	91-059 941-04/009 91-059 941-04/010 91-059 941-04/011 91-059 941-04/012 91-059 941-04/012
7 - 9		91-154 625-91
7		91-057 714-91
8		91-057 698-15
9		11-108 168-15
10 - 13		09-009 844-35
10		99-117 869-23
11		91-100 120-25
12		12-305 114-25
13		11-132 223-15
14		99-117 868-23

## -6/01-900/81;/82 BN8<sup>◆</sup>

Für allgemeine Näharbeiten.  
Standardform des Teilesatzes.

For ordinary sewing operations.  
Standard part set.

Travaux d'utilité courante.  
Jeu de pièces standard.

Para trabajos de costura en general.  
Juego de piezas estándar.

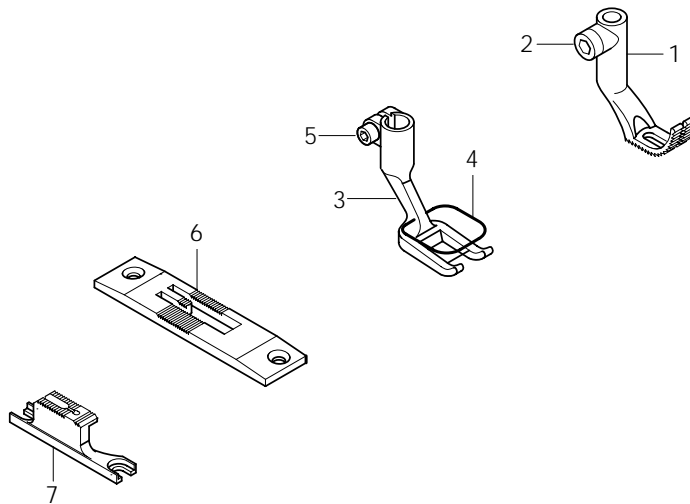

Pos.-Nr. Item No. N° pos. N° de pos.	Teile-Nr. Part No. N° de piezas N° de pieza
1 - 2	91-049 394-93/004
2	11-132 217-15
3 - 5	91-149 162-93/003
4	91-149 163-05 <span style="border: 1px solid black; padding: 0 2px;">3/1</span>

Pos.-Nr. Item No. N° pos. N° de pos.	Teile-Nr. Part No. N° de piezas N° de pieza
5	11-130 173-15
6	91-150 602-05
7	91-059 935-04/001

-6/07-900/81;/82 BN8<sup>◆</sup>

Für Nähte mit Übergängen  
 (Kletterteilesatz).

For seams involving cross seams  
 (climbing parts set).

Couture de matières à suré-  
 paiseurs (pied grim pant).

Para costuras con desniveles  
 (juego de piezas trepador).

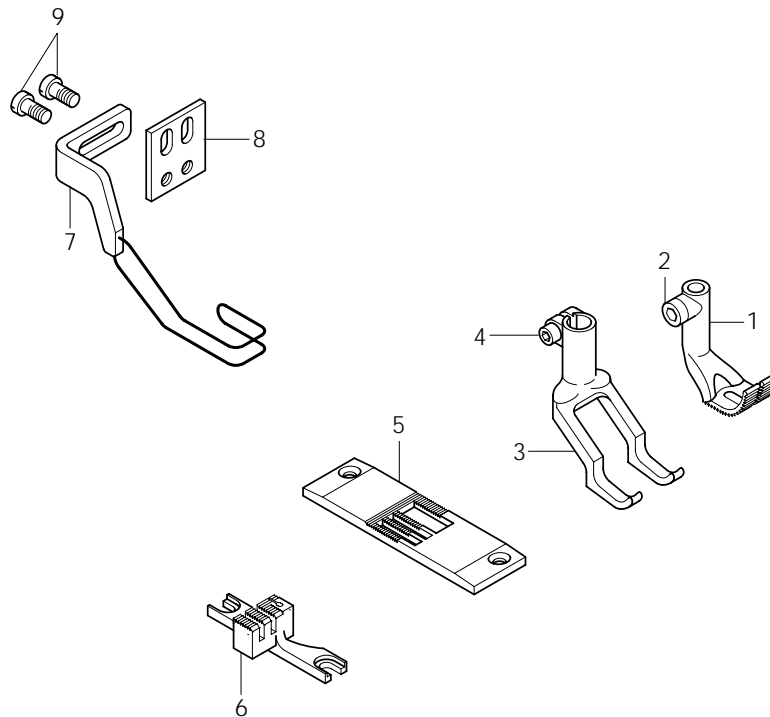

Pos.-Nr. Item No. N° pos.	Teil-Nr. Part No. N° de piezas N° de pieza
1 - 2	91-049 394-93/004
2	11-132 217-15
3 - 4	91-049 772-93/022
4	11-130 173-15
5	91-150 600-04/001

Pos.-Nr. Item No. N° pos.	Teil-Nr. Part No. N° de piezas N° de pieza
6	91-059 933-04/003
7 - 9	91-154 696-91
7	91-154 697-91
8	91-057 698-15
9	11-108 171-15

## -6/07-900/81;/82 CN8♦

Für Nähte mit Übergängen  
(Kletterteilesatz).

For seams involving cross seams  
(climbing parts set).

Couture de matières à suré-  
passeurs (pied grim pant).

Para costuras con desniveles  
(juego de piezas trepador).

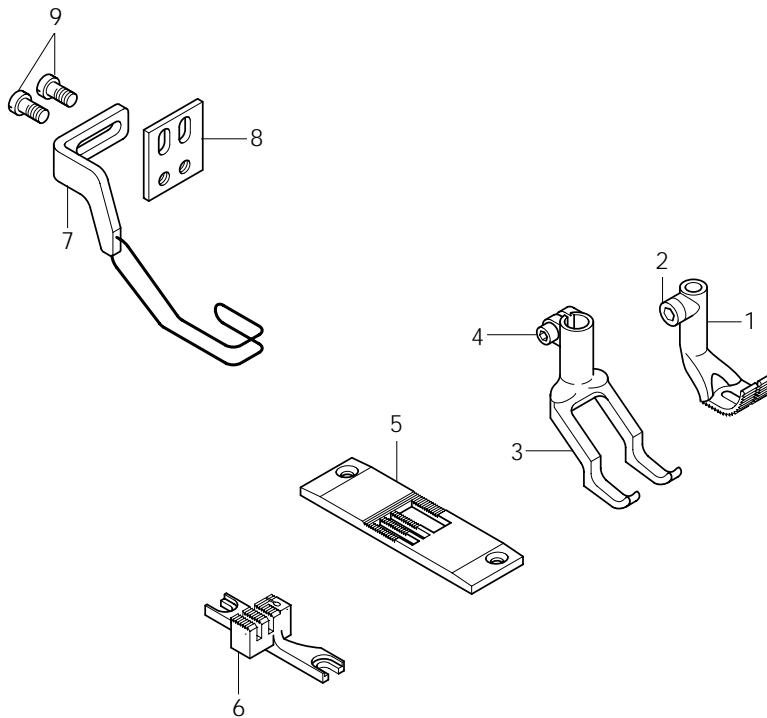

Pos.-Nr. Item No. N° pos. N° de pos.	Teile-Nr. Part No. N° de pièces N° de pieza
1 - 9	91-201 795-93/001
1 - 2	91-049 394-93/003
2	11-132 217-15
3 - 4	91-049 772-93/032
4	11-130 173-15
5	91-150 600-04/001

Pos.-Nr. Item No. N° pos. N° de pos.	Teile-Nr. Part No. N° de pièces N° de pieza
6	91-059 933-04/001
7 - 9	91-154 696-91
7	91-154 697-91
8	91-057 698-15
9	11-108 171-15

-6/13-900/81;/82 BN8<sup>◆</sup>

Für allgemeine Näharbeiten;  
 jedoch mit Dacron-Fußpaar.

For ordinary sewing operations  
 but with Dacron feet pair.

Travaux d'utilité courante,  
 mais avec paire de pieds  
 avec semelle en Dacron.

Para trabajos de costura en general,  
 preo con planta de Dacron.

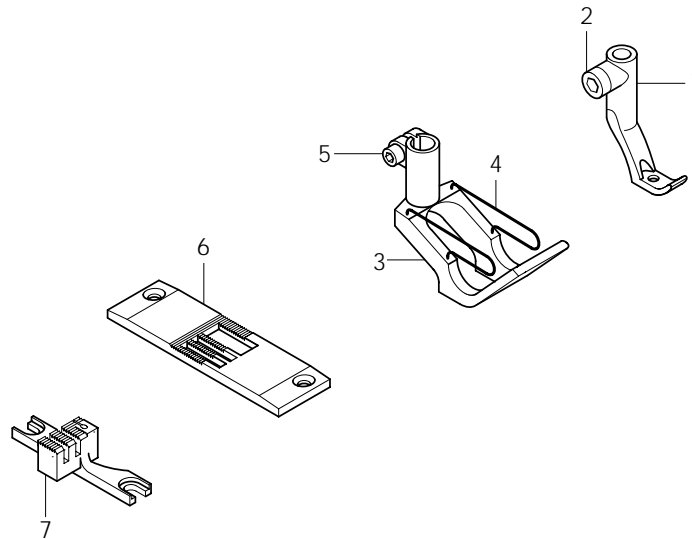

Pos.-Nr. Item No. N° pos. N° de pos.	Teile-Nr. Part No. N° de pièces N° de pieza
1 - 2	91-049 408-93/008
2	11-132 217-15
3 - 5	91-149 159-91
4	91-149 161-05 <span style="border: 1px solid black; padding: 0 2px;">3/1</span>

Pos.-Nr. Item No. N° pos. N° de pos.	Teile-Nr. Part No. N° de pièces N° de pieza
5	11-130 173-15
6	91-150 600-04/001
7	91-059 933-04/003

-6/13-900/81;/82 CN8<sup>◆</sup>

Für allgemeine Näharbeiten;  
jedoch mit Dacron-Fußpaar.

For ordinary sewing operations  
but with Dacron feet pair.

Travaux d'utilité courante,  
mais avec paire de pieds  
avec semelle en Dacron.

Para trabajos de costura en general,  
preo con planta de Dacron.

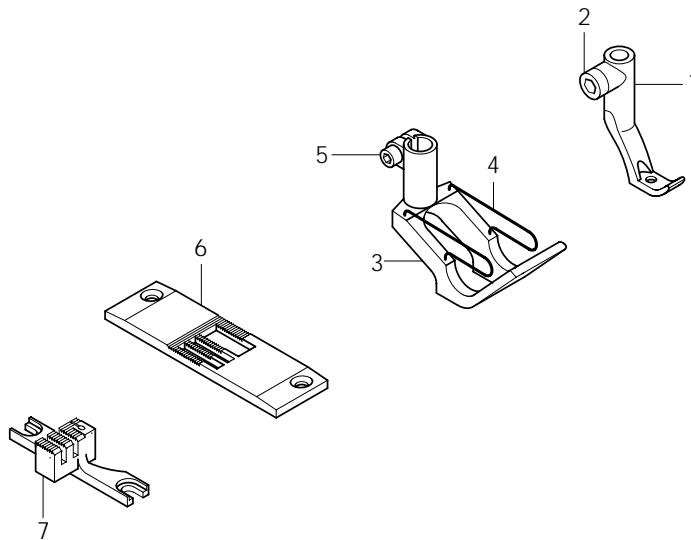

Pos.-Nr. Item No. N° pos. N° de pos.	Teile-Nr. Part No. N° de pièces N° de pieza
1 - 7	91-201 796-93/001
1 - 2	91-049 408-93/001
2	11-132 217-15
3 - 5	91-149 159-91

Pos.-Nr. Item No. N° pos. N° de pos.	Teile-Nr. Part No. N° de pièces N° de pieza
4	91-149 161-05 <span style="border: 1px solid black; padding: 0 2px;">3/1</span>
5	11-130 173-15
6	91-150 600-04/001
7	91-059 933-04/001



-6/14-900/81;/82 CN8♦

Für allgemeine Näharbeiten.  
 Standardform des Teilesatzes.

For ordinary sewing operations.  
 Standard part set.

Travaux d'utilité courante.  
 Jeu de pièces standard.

Para trabajos de costura en general.  
 Juego de piezas estándar.

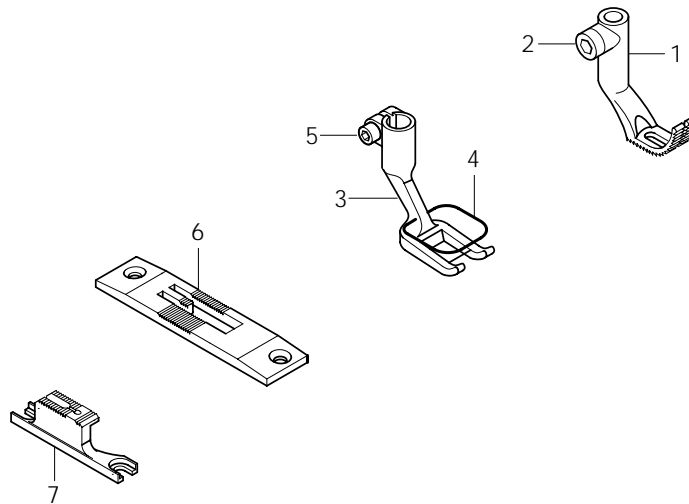

Pos.-Nr. Item No. N° pos. N° de pos.	Teile-Nr. Part No. N° de pièces N° de pieza
1 - 7	91-202 377-93/001
1 - 2	91-049 394-93/003
2	11-132 217-15
3 - 5	91-149 162-93/001

Pos.-Nr. Item No. N° pos. N° de pos.	Teile-Nr. Part No. N° de pièces N° de pieza
4	91-149 163-05 <span style="border: 1px solid black; padding: 0 2px;">3/1</span>
5	11-130 173-15
6	91-150 602-05
7	91-059 935-04/001

## -6/17-900/81;/82 BN8♦

Für allgemeine Näharbeiten;  
jedoch mit Schiffchenfuß.

For ordinary sewing operations  
but with boat-shaped foot.

Travaux d'utilité courante,  
mais avec pied-bâteau.

Para trabajos de costura en general,  
preo con pie tipo barco.

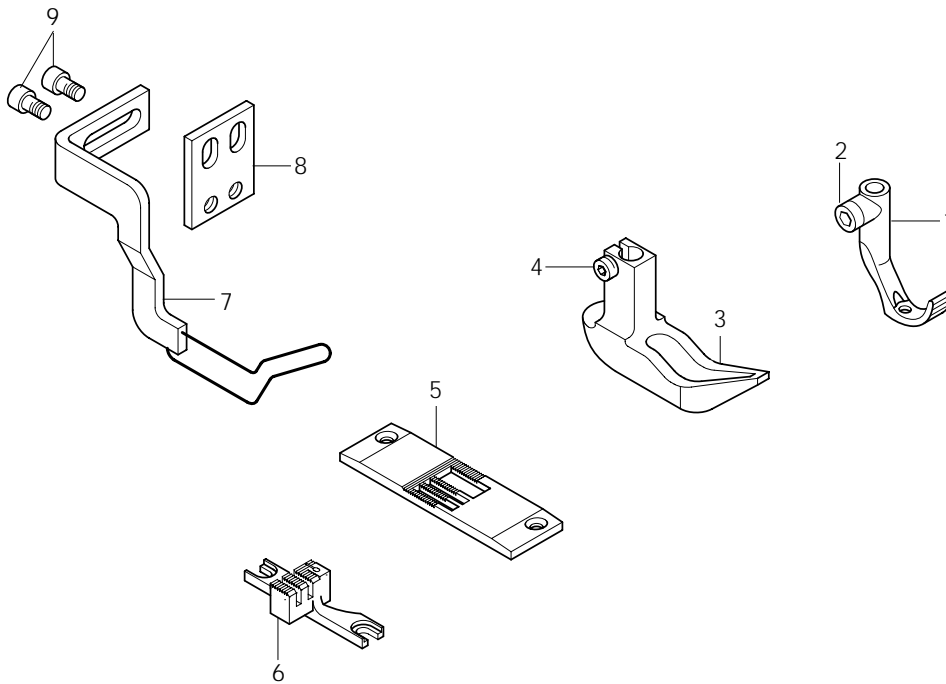

Pos.-Nr. Item No. N° pos. N° de pos.	Teile-Nr. Part No. N° de pièces N° de piezas
1 - 9	91-201 797-93/001
1 - 2	91-149 110-93/003
2	11-132 217-15
3 - 4	91-049 961-92
4	11-330 277-15
5	91-150 600-04/001

Pos.-Nr. Item No. N° pos. N° de pos.	Teile-Nr. Part No. N° de pièces N° de piezas
6	91-059 933-04/003
7 - 9	91-154 484-91
7	91-154 485-91
8	91-057 698-15
9	11-130 167-15

**-6/17-900/81;/82 CN8<sup>◆</sup>**

Für allgemeine Näharbeiten;  
 jedoch mit Schiffchenfuß.

For ordinary sewing operations  
 but with boat-shaped foot.

Travaux d'utilité courante,  
 mais avec pied-bâteau.

Para trabajos de costura en general,  
 preo con pie tipo barco.

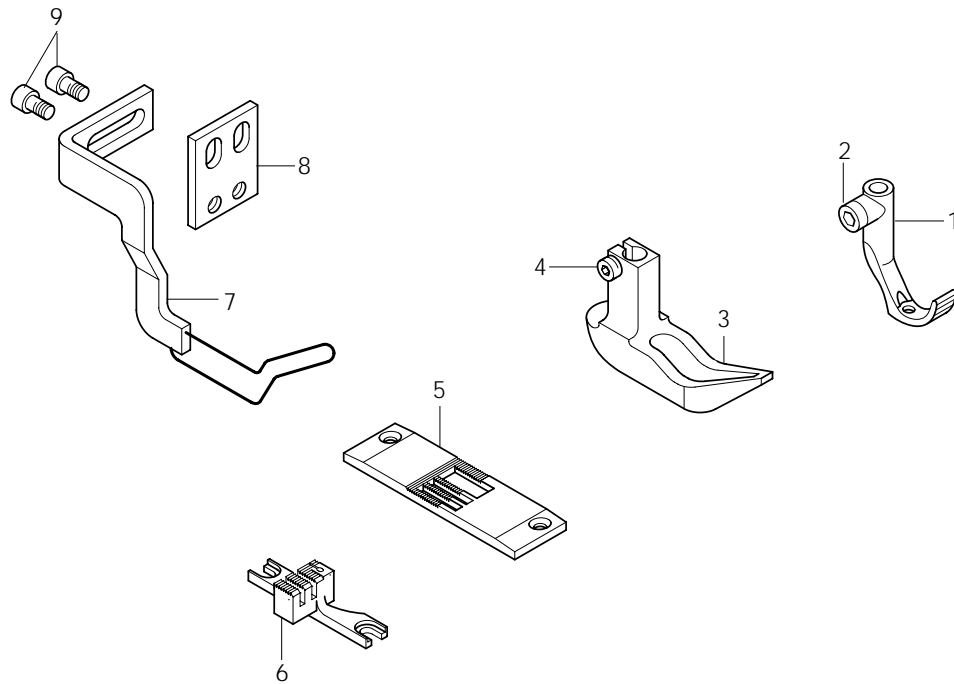

Pos.-Nr. Item No. N° pos. N° de pos.	Teile-Nr. Part No. N° de pièces N° de pieza
1 - 9	91-201 797-93/002
1 - 2	91-149 110-93/002
2	11-132 217-15
3 - 4	91-049 961-92
4	11-330 277-15
5	91-150 600-04/001

Pos.-Nr. Item No. N° pos. N° de pos.	Teile-Nr. Part No. N° de pièces N° de pieza
6	91-059 933-04/001
7 - 9	91-154 484-91
7	91-154 485-91
8	91-057 698-15
9	11-130 167-15

-17/01-900/81;/82 BN8<sup>◆</sup>

Arbeitsgang  
Operation  
Opération  
Opéracion

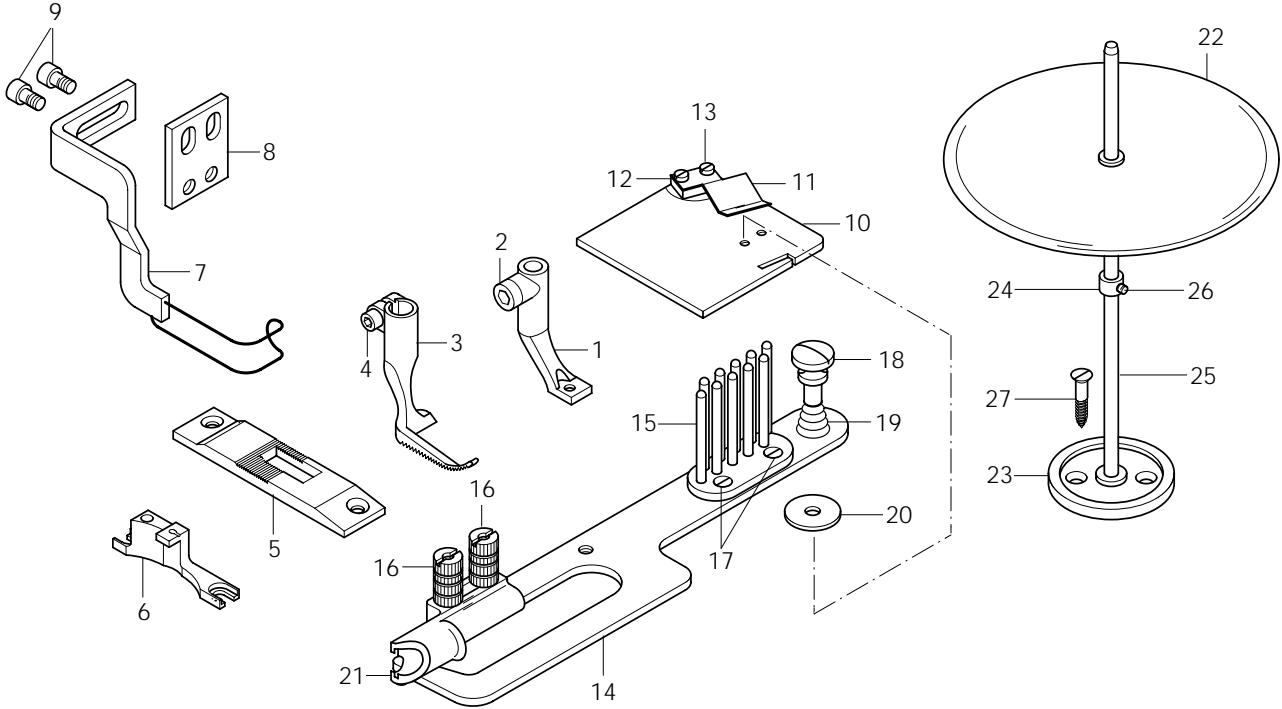
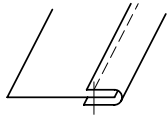

Pos.-Nr. Item No. N° pos. N° de pos.	Teile-Nr. Part No. N° de pièces N° de piezas
1 - 2	91-049 491-93/007
2	11-132 217-15
3 - 4	91-049 862-93/001
4	11-130 173-15
5	91-150 601-05
6	91-059 934-04/001
7 - 9	91-155 426-91
7	91-155 427-91
8	91-057 698-15
9	11-130 167-15
10 - 13	91-266 407-91
10	91-266 406-25
11	91-170 364-15
12	91-170 363-15
13	11-108 174-15
14 - 20	91-156 269-90

Pos.-Nr. Item No. N° pos. N° de pos.	Teile-Nr. Part No. N° de pièces N° de piezas
14	91-053 752-23/003
15	91-044 251-21
16	91-001 592-25
17	91-000 380-25
18	91-000 824-25
19	91-040 624-25
20	91-028 036-25
21	91-040 533-23/012
22 - 27	91-043 943-70/895
22	91-043 124-71/895
23	91-043 945-75/895
24	91-043 947-92
25	91-043 946-25
26	91-000 388-15
27	11-470 355-25

-17/01-900/81;/82 CN8♦

Arbeitsgang  
 Operation  
 Opération  
 Operación

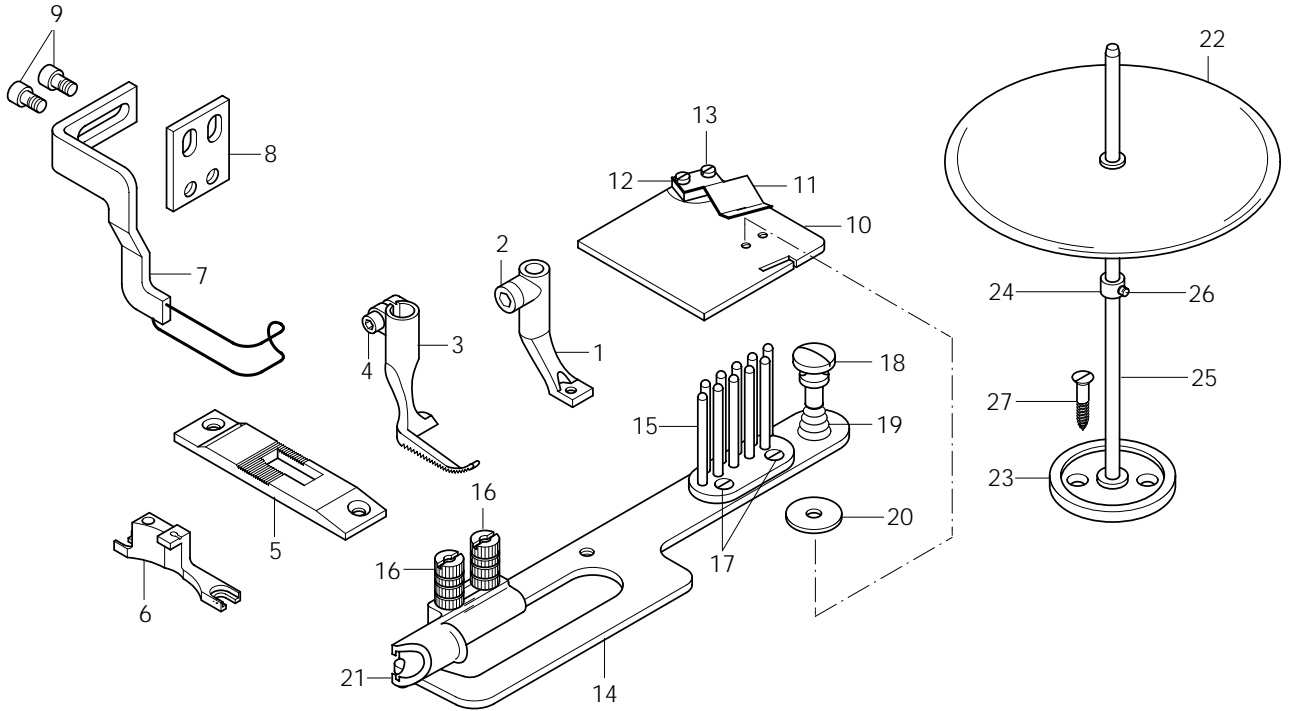
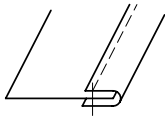

Pos.-Nr. Item No. N° pos. N° de pos.	Teile-Nr. Part No. N° de pièces N° de piezas
1 - 2	91-049 491-93/001
2	11-132 217-15
3 - 4	91-049 862-93/002
4	11-130 173-15
5	91-150 601-05
6	91-059 934-04/002
7 - 9	91-155 426-91
7	91-155 427-91
8	91-057 698-15
9	11-130 167-15
10 - 13	91-266 407-91
10	91-266 406-25
11	91-170 364-15
12	91-170 363-15
13	11-108 174-15
14 - 20	91-156 269-90

Pos.-Nr. Item No. N° pos. N° de pos.	Teile-Nr. Part No. N° de pièces N° de piezas
14	91-053 752-23/003
15	91-044 251-21
16	91-001 592-25
17	91-000 380-25
18	91-000 824-25
19	91-040 624-25
20	91-028 036-25
21	91-040 533-23/012
22 - 27	91-043 943-70/895
22	91-043 124-71/895
23	91-043 945-75/895
24	91-043 947-92
25	91-043 946-25
26	91-000 388-15
27	11-470 355-25

## -34/01-900/81 BN8♦

Zum Nähen feiner Materialien mit dicken Fäden.  
Standardform des Teilesatzes.

For sewing light fabrics with thick threads.  
Standard-size part set.

Pour la couture de matières fines avec de gros fils.  
Jeu de pièces standard.

Para coser materiales finos con hilos espesos.  
Juego de piezas estándar.

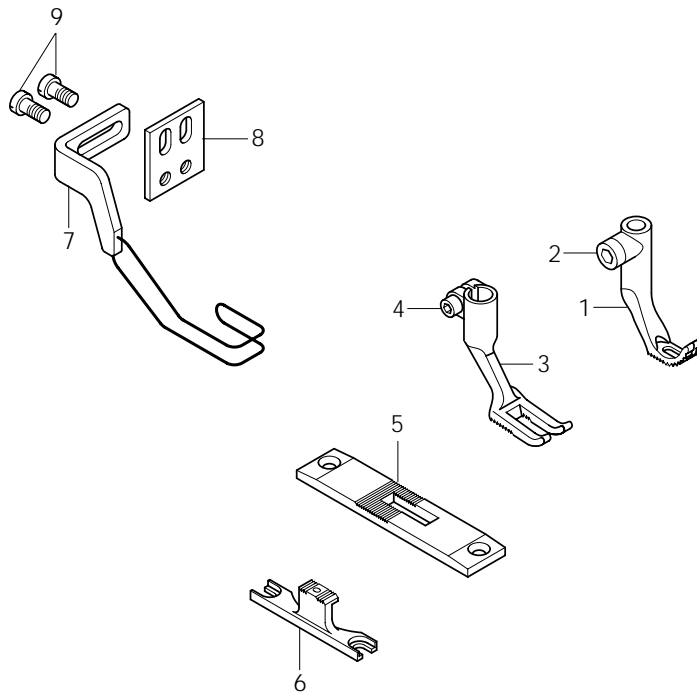

Pos.-Nr. Item No. N° pos. N° de pos.	Teile-Nr. Part No. N° de pièces N° de pieza
1 - 6	91-202 400-93/002
1 - 2	91-049 395-93/001
2	11-132 217-15
3 - 4	91-049 803-93/001
4	11-130 173-15
5	91-150 767-04/001

Pos.-Nr. Item No. N° pos. N° de pos.	Teile-Nr. Part No. N° de pièces N° de pieza
6	91-059 286-04/002
7 - 9	91-154 696-91
7	91-154 697-91
8	91-057 698-15
9	11-108 171-15

-34/01-900/81 CN8<sup>◆</sup>

Zum Nähen feiner Materialien mit dicken Fäden.  
 Standardform des Teilesatzes.

For sewing light fabrics with thick threads.  
 Standard-size part set.

Pour la couture de matières fines. Jeu de pièces standard.

Para coser materiales finos con hilos espesos.  
 Juego de piezas estándar.

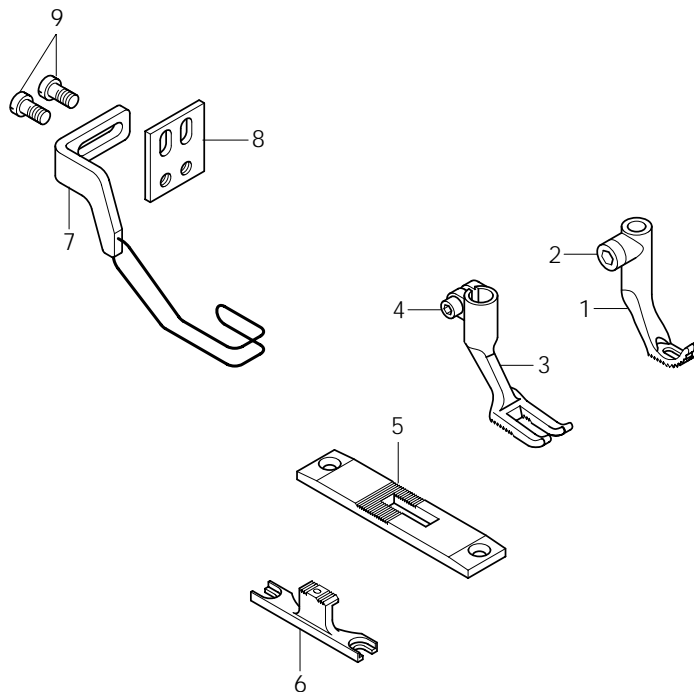

Pos.-Nr. Item No. N° pos. N° de pos.	Teile-Nr. Part No. N° de pièces N° de pieza	Pos.-Nr. Item No. N° pos. N° de pos.	Teile-Nr. Part No. N° de pièces N° de pieza
1 - 6	91-202 400-93/001	6	91-059 286-04/003
1 - 2	91-049 395-93/002	7 - 9	91-154 696-91
2	11-132 217-15	7	91-154 697-91
3 - 4	91-049 803-93/002	8	91-057 698-15
4	11-130 173-15	9	11-108 171-15
5	91-150 767-05		

-40/01-900/81;/82 CN8♦

Arbeitsgang  
Operation  
Opération  
Opéracion

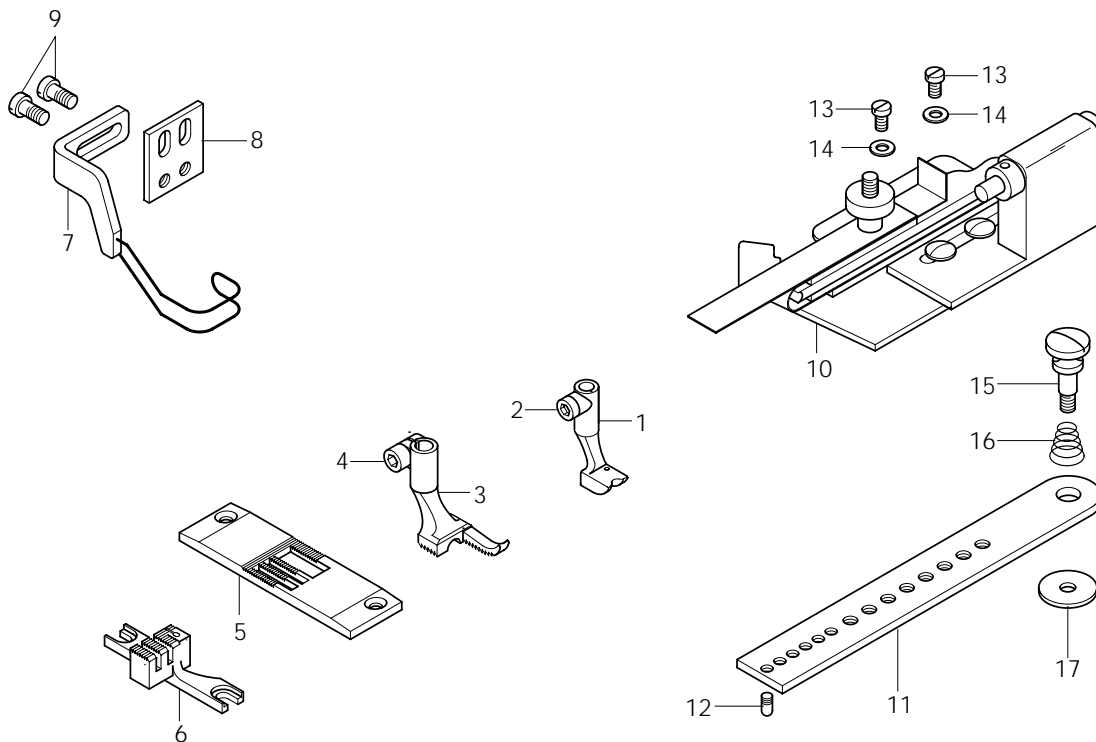
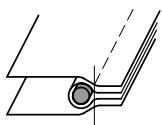

Pos.-Nr. Item No. N° pos. N° de pos.	Kederdicke Thickness of welting Grosseur du bourrelet Grosor del vivo	Teile-Nr. Part No. N° de piezas N° de pieza
1 - 2	4,0 5,0 5,5 6,5 7,0 8,0 10,0	91-049 382-93/007 91-049 382-93/003 91-049 382-93/004 91-049 382-93/006 91-049 382-93/001 91-049 382-93/002 91-049 382-93/009
2		11-132 217-15
3 - 4	4,0 5,0 5,5 6,5 7,0 8,0 10,0	91-049 989-93/003 91-049 989-93/004 91-049 989-93/005 91-049 989-93/006 91-049 989-93/009 91-049 989-93/007 91-049 989-93/008
4		11-130 173-15
5		91-150 600-04/001
6		91-059 933-04/001
7 - 9		91-155 429-91
7		91-155 430-91

Pos.-Nr. Item No. N° pos. N° de pos.	Kederdicke Thickness of welting Grosseur du bourrelet Grosor del vivo	Teile-Nr. Part No. N° de piezas N° de pieza
8		91-057 698-15
9		11-130 167-15
10	4,0 5,0 5,5 6,5 7,0 8,0 10,0	91-156 701-93/002 91-156 701-93/003 91-156 701-93/004 91-156 701-93/005 91-156 701-93/005 91-156 701-93/006 91-156 701-93/008
11 - 17		91-156 263-90
11		91-042 940-25
12		91-000 775-15
13		91-000 089-15
14		12-315 110-15
15		91-700 824-25
16		91-040 624-25
17		91-028 036-25



-40/12-900/81;/82 CN8♦

Arbeitsgang  
Operation  
Opération  
Operación

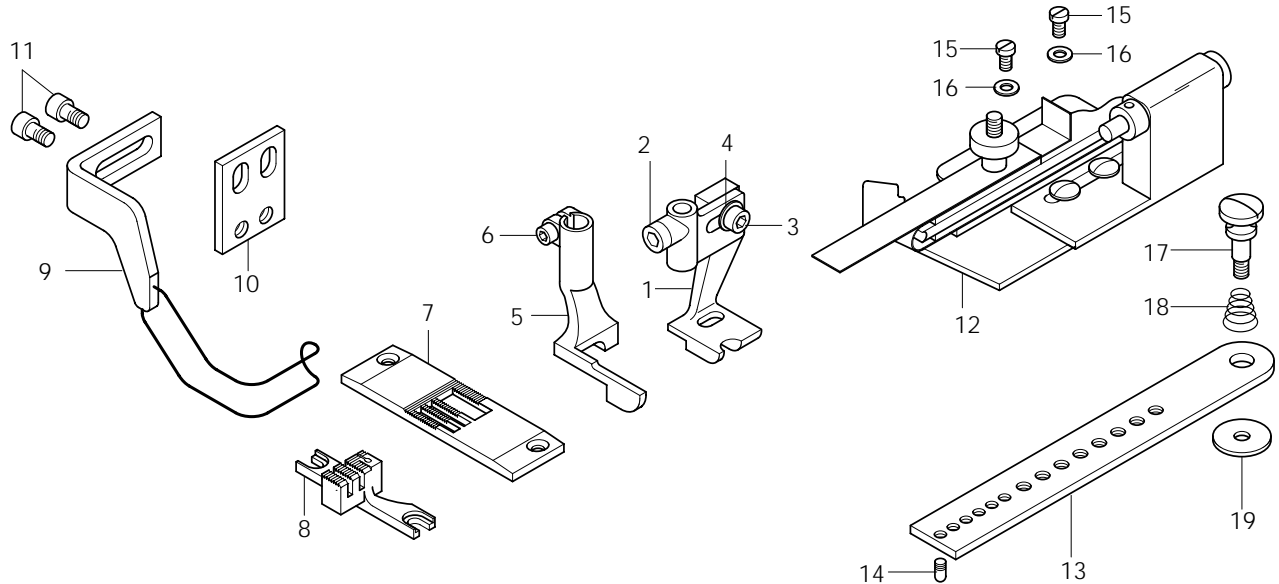
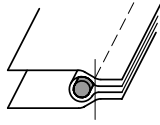

Pos.-Nr. Item No. N° pos.	Kederdicke Thickness of welting Grosseur du bourrelet Grosor del vivo	Teile-Nr. Part No. N° de piezas
1 - 19	5,0 6,0 7,0 9,0	91-201 802-93/004 91-201 802-93/005 91-201 802-93/006 91-201 802-93/007
1 - 4	3,0 4,0 5,0 6,0 7,0 8,0 9,0 10,0	91-049 402-93/007 91-049 402-93/001 91-049 402-93/003 91-049 402-93/004 91-049 402-93/008 91-049 402-93/006 91-049 402-93/009 91-049 402-93/010
2		11-132 217-15
3		11-130 173-15
4		12-315 110-15
5 - 6	3,0 4,0 5,0 6,0 7,0 8,0 9,0 10,0	91-049 782-93/007 91-049 782-93/001 91-049 782-93/003 91-049 782-93/004 91-049 782-93/008 91-049 782-93/006 91-049 782-93/009 91-049 782-93/010
6		11-130 173-15
7		91-150 600-04/001

Pos.-Nr. Item No. N° pos.	Kederdicke Thickness of welting Grosseur du bourrelet Grosor del vivo	Teile-Nr. Part No. N° de piezas
8		91-059 933-04/001
9 - 11		91-155 433-91
9		91-155 434-91
10		91-057 698-15
11		11-130 167-15
12	3,0 4,0 5,0 6,0 7,0 8,0 9,0 10,0	91-156 701-93/001 91-156 701-93/002 91-156 701-93/003 91-156 701-93/004 91-156 701-93/005 91-156 701-93/006 91-156 701-93/006 91-156 701-93/008
13 - 19		91-156 263-90
13		91-042 940-25
14		91-000 775-15
15		91-000 089-15
16		12-315 110-15
17		91-700 824-25
18		91-040 624-25
19		91-028 036-25

## -40/14-900/81;/82 BN8♦

Arbeitsgang  
Operation  
Opération  
Opéracion

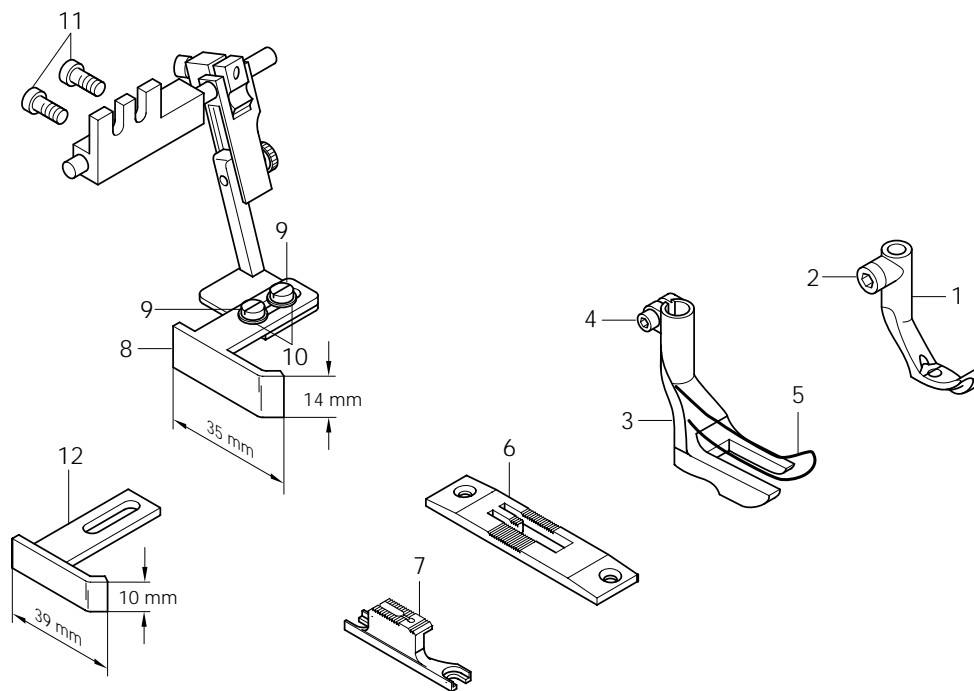
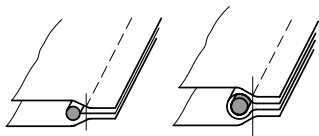

Pos.-Nr. Item No. N° pos. N° de pos.	Kederdicke Thickness of welting Grosseur du bourrelet Grosor del vivo	Teile-Nr. Part No. N° de piezas N° de pieza
1 - 11	5,0 7,0 9,0	91-201 803-93/001 91-201 803-93/002 91-201 803-93/003
1 - 2	4,0 5,0 6,0 7,0 9,0	91-049 490-93/004 91-049 490-93/003 91-049 490-93/003 91-049 490-93/003 91-049 490-93/003
2		11-132 217-15
3 - 5	4,0 5,0 6,0 7,0 9,0	91-149 169-93/006 91-149 169-93/001 91-149 169-93/004 91-149 169-93/002 91-149 169-93/003

Pos.-Nr. Item No. N° pos. N° de pos.	Kederdicke Thickness of welting Grosseur du bourrelet Grosor del vivo	Teile-Nr. Part No. N° de piezas N° de pieza
4		11-130 173-15
5		91-149 180-15 <span style="border: 1px solid black; padding: 0 2px;">3/1</span>
6		91-150 602-05
7		91-059 935-04/001
8 - 11		09-009 824-22
8		99-117 869-23
9		91-100 120-25
10		12-305 114-25
11		11-132 223-15
12		99-117 868-23

-40/14-900/81;/82 CN8♦

Arbeitsgang  
Operation  
Opération  
Operación

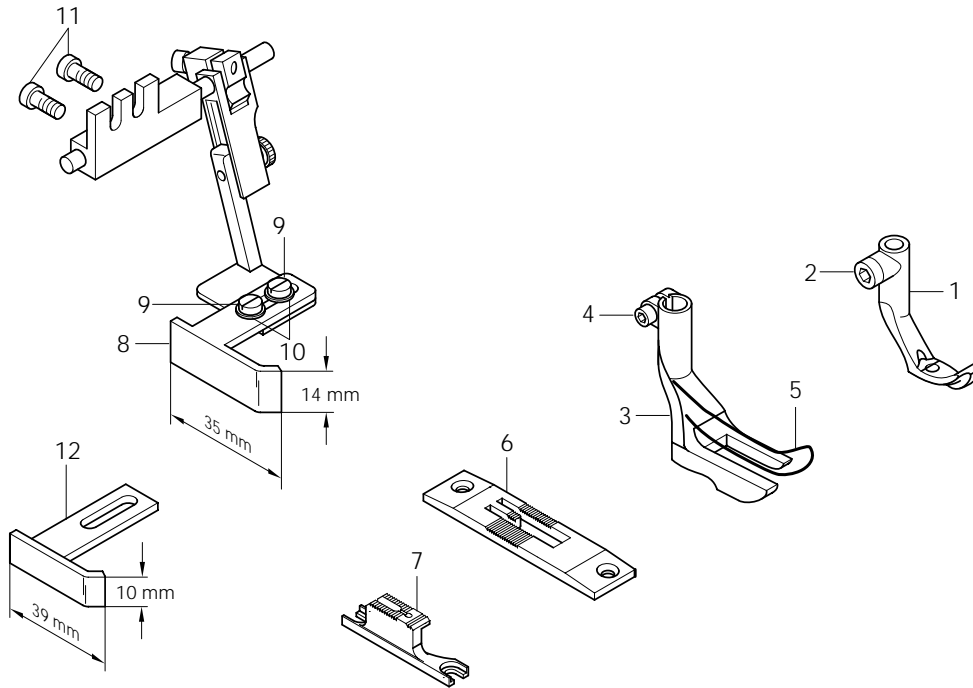
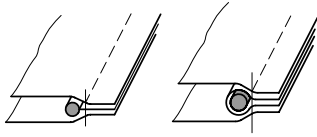

Pos.-Nr. Item No. N° pos. N° de pos.	Kederdicke Thickness of welting Grosueur du bourrelet Grosor del vivo	Teile-Nr. Part No. N° de piezas N° de piezas
1 - 11	5,0 6,0 7,0 9,0	91-201 803-93/004 91-201 803-93/007 91-201 803-93/005 91-201 803-93/006
1 - 2	4,0 5,0 6,0 7,0 9,0 11,0	91-049 490-93/401 91-049 490-93/001 91-049 490-93/001 91-049 490-93/001 91-049 490-93/001 91-049 490-93/002
2		11-132 217-15
3 - 5	4,0 5,0 6,0 7,0 9,0 11,0	91-149 169-93/006 91-149 169-93/001 91-149 169-93/004 91-149 169-93/002 91-149 169-93/003 91-149 169-93/005

Pos.-Nr. Item No. N° pos. N° de pos.	Kederdicke Thickness of welting Grosueur du bourrelet Grosor del vivo	Teile-Nr. Part No. N° de piezas N° de piezas
4		11-130 173-15
5		91-149 180-15 <span style="border: 1px solid black; padding: 0 2px;">3/1</span>
6		91-150 602-05
7		91-059 935-04/002
8 - 11		09-009 824-22
8		99-117 869-23
9		91-100 120-25
10		12-305 114-25
11		11-132 223-15
12		99-117 868-23

-113/05-900/81;/82 BN8♦

Arbeitsgang  
Operation  
Opération  
Operación

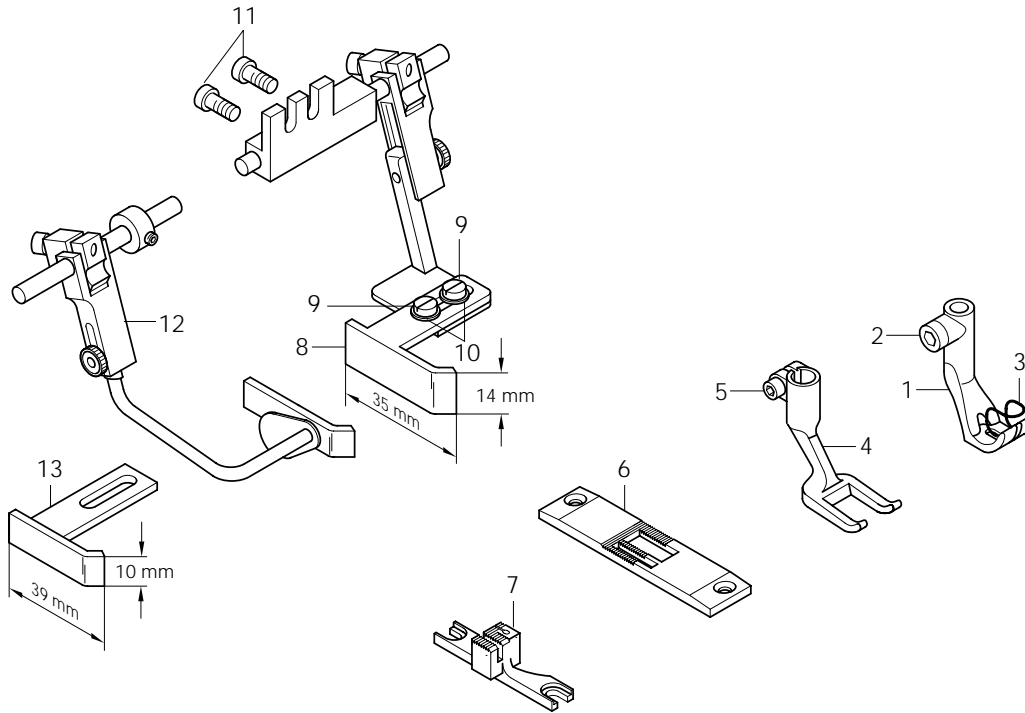
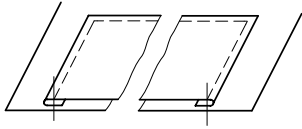

Pos.-Nr. Item No. N° pos. N° de pos.	Kederdicke Thickness of welting Grosseur du bourrelet Grosor del vivo	Teile-Nr. Part No. N° de piezas N° de pieza
1 - 12	3,0	91-201 804-93/001
	3,5	91-201 804-93/003
	4,0	91-201 804-93/005
1 - 3	3,0	91-149 174-93/001
	3,5	91-149 174-93/002
	4,0	91-149 174-93/003
	4,5	91-149 174-93/004
	5,0	91-149 174-93/005
2		11-132 217-15
3		91-149 117-05 <span style="border: 1px solid black; padding: 0 2px;">3/1</span>
4 - 5	3,0	91-149 179-93/013
	3,5	91-149 179-93/015
	4,0	91-049 964-93/004
	4,5	91-049 964-93/005
	5,0	91-049 964-93/006

Pos.-Nr. Item No. N° pos. N° de pos.	Kederdicke Thickness of welting Grosseur du bourrelet Grosor del vivo	Teile-Nr. Part No. N° de piezas N° de pieza
5		11-130 173-15
6		91-150 600-04/002
7		91-059 933-04/004
8 - 12		09-009 842-60
8 - 11		09-009 824-22
8		99-117 869-23
9		91-100 120-25
10		12-305 114-25
11		11-132 223-15
12		09-009 859-87
13		99-117 868-23

-113/05-900/81;/82 CN8♦

Arbeitsgang  
 Operation  
 Opération  
 Operación

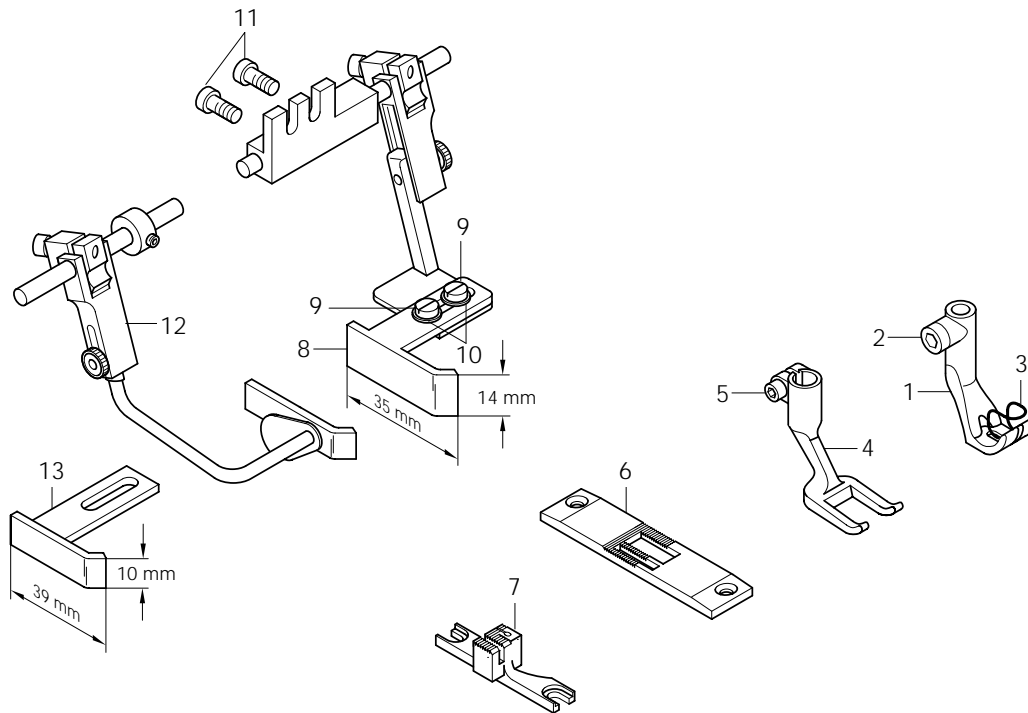
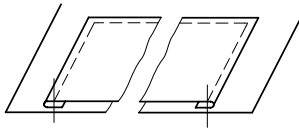

Pos.-Nr. Item No. N° pos. N° de pos.	Kederdicke Thickness of welting Grosneur du bourrelet Grosor del vivo	Teile-Nr. Part No. N° de piezas N° de piezas
1 - 12	3,0 3,5 4,0	91-201 804-93/002 91-201 804-93/004 91-201 804-93/006
1 - 3	3,0 3,5 4,0 4,5 5,0	91-149 174-93/006 91-149 174-93/007 91-149 174-93/008 91-149 174-93/009 91-149 174-93/010
2		11-132 217-15
3		91-149 117-05 [3/1]
4 - 5	3,0 3,5 4,0 4,5 5,0	91-149 179-93/014 91-149 179-93/016 91-049 964-93/001 91-049 964-93/002 91-049 964-93/003

Pos.-Nr. Item No. N° pos. N° de pos.	Kederdicke Thickness of welting Grosneur du bourrelet Grosor del vivo	Teile-Nr. Part No. N° de piezas N° de piezas
5		11-130 173-15
6		91-150 600-04/002
7		91-059 933-04/005
8 - 12		09-009 842-60
8 - 11		09-009 824-22
8		99-117 869-23
9		91-100 120-25
10		12-305 114-25
11		11-132 223-15
12		09-009 859-87
13		99-117 868-23

-731/02-6/01-900/81;/82 BN8♦

Arbeitsgang  
Operation  
Opération  
Operación

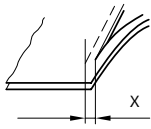

x = 3,5; 4,0; 5,0 mm  
5,0 mm = Standard  
5,0 mm = standard  
5,0 mm = standard  
5,0 mm = estándar

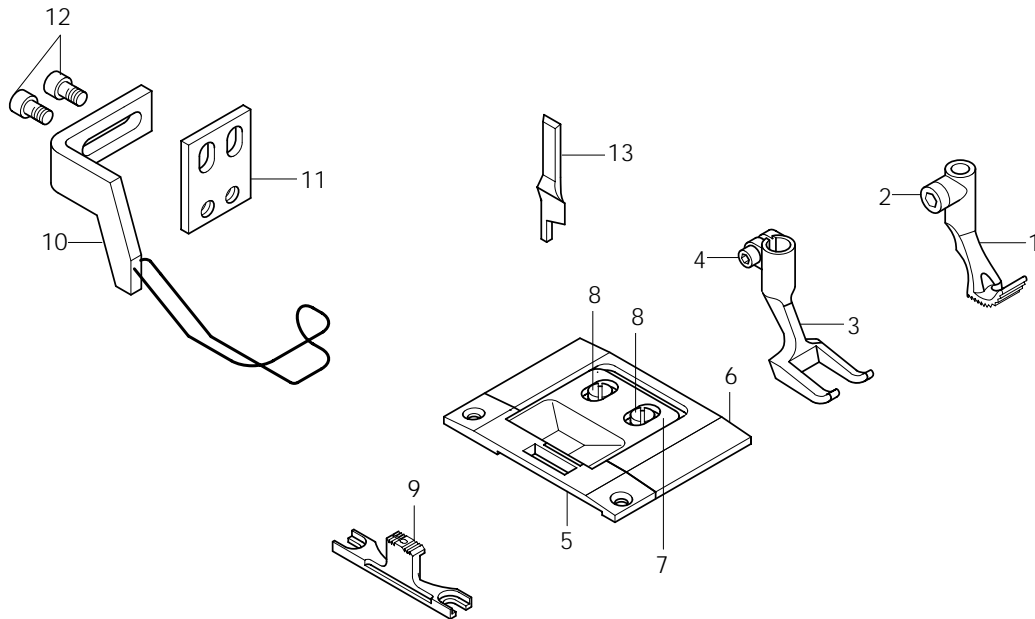

Pos.-Nr. Item No. N° pos.	Schneidabstand Trimming margin Distance de coupe Margen de corte	Teile-Nr. Part No. N° de piezas
1 - 13	3,5	91-201 810-93/001
1 - 2	3,5	91-149 039-93/007
	4,0	91-149 039-93/005
	5,0	91-149 039-93/006
2		11-132 217-15
3 - 4	3,5	91-149 177-93/001
	4,0	91-149 177-93/002
	5,0	91-149 177-93/004
4		11-130 173-15
5 - 8	3,5	91-150 615-93/001
	4,0	91-150 615-93/002
	5,0	91-150 615-93/004
5	3,5	91-150 616-93/001
	4,0	91-150 616-93/002

Pos.-Nr. Item No. N° pos.	Schneidabstand Trimming margin Distance de coupe Margen de corte	Teile-Nr. Part No. N° de piezas
	5,0	91-150 616-93/004
6		91-150 130-05
7		91-150 133-01
8		91-100 293-25
9		91-059 940-04/002
10 - 12		91-154 633-91
10		91-154 634-91
11		91-057 698-15
12		11-130 167-15
13	3,5	91-166 700-04/003
	4,0	91-166 700-04/003
	5,0	91-166 701-04/005

-731/02-6/01-900/81;/82 CN8♦

Arbeitsgang  
 Operation  
 Opération  
 Operación

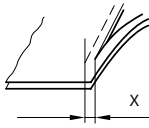

x = 3,5; 5,0; 6,0; 8,0 mm  
 5,0 mm = Standard  
 5,0 mm = standard  
 5,0 mm = standard  
 5,0 mm = estándar

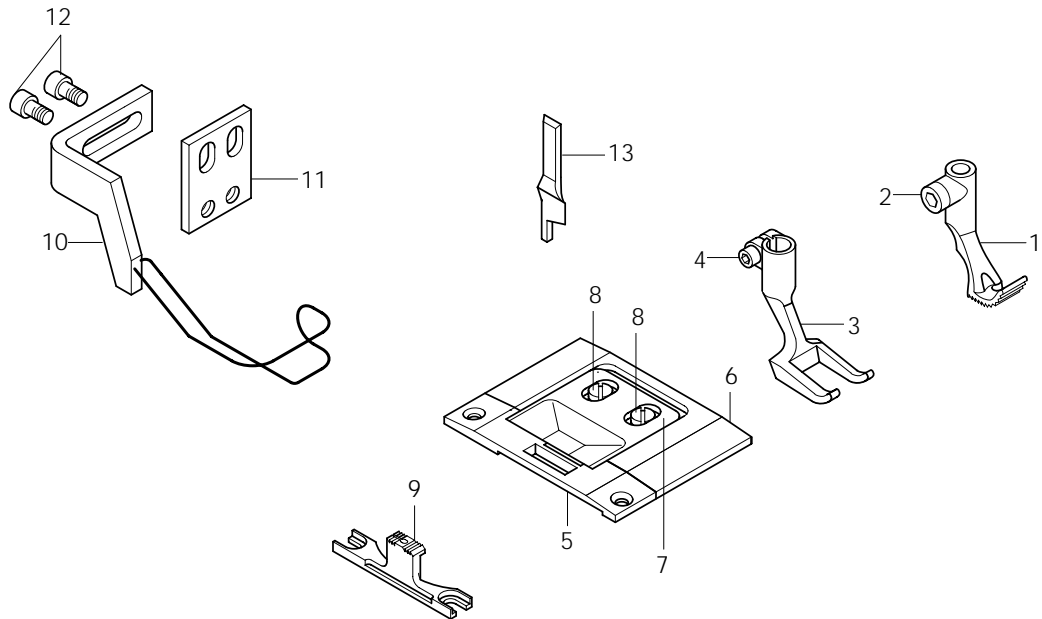

Pos.-Nr. Item No. N° pos. N° de pos.	Schneidabstand Trimming margin Distance de coupe Margen de corte	Teile-Nr. Part No. N° de piezas N° de piezas
1 - 13	3,5 5,0 6,0 8,0	91-201 810-93/002 91-201 810-93/003 91-201 810-93/001 91-201 810-93/004
1 - 2	3,5 5,0 6,0 8,0	91-149 039-93/008 91-149 039-93/002 91-149 039-93/004 91-149 039-93/003
2		11-132 217-15
3 - 4	3,5 5,0 6,0 8,0	91-149 177-93/011 91-149 177-93/014 91-149 177-93/016 91-149 177-93/020
4		11-130 173-15
5 - 8	3,5 5,0 6,0 8,0	91-150 615-93/001 91-150 615-93/004 91-150 615-93/006 91-150 615-93/010

Pos.-Nr. Item No. N° pos. N° de pos.	Schneidabstand Trimming margin Distance de coupe Margen de corte	Teile-Nr. Part No. N° de piezas N° de piezas
5	3,5 5,0 6,0 8,0	91-150 616-93/001 91-150 616-93/004 91-150 616-93/006 91-150 616-93/010
6		91-150 130-05
7		91-150 133-01
8		91-100 293-25
9	3,5; 5,0; 6,0 8,0	91-059 940-04/003 91-059 940-04/006
10 - 12		91-154 633-91
10		91-154 634-91
11		91-057 698-15
12		11-130 167-15
13	3,5 5,0; 6,0 8,0	91-166 700-04/002 91-166 701-04/005 91-166 701-04/006

-2/08-900/81;/82 CN8♦

Für allgemeine Näharbeiten.  
Standardform des Teilesatzes.  
Lineal hochklappbar.

Für allgemeine Näharbeiten.  
Standardform des Teilesatzes.  
Lineal hochklappbar.

Für allgemeine Näharbeiten.  
Standardform des Teilesatzes.  
Lineal hochklappbar.

Für allgemeine Näharbeiten.  
Standardform des Teilesatzes.  
Lineal hochklappbar.

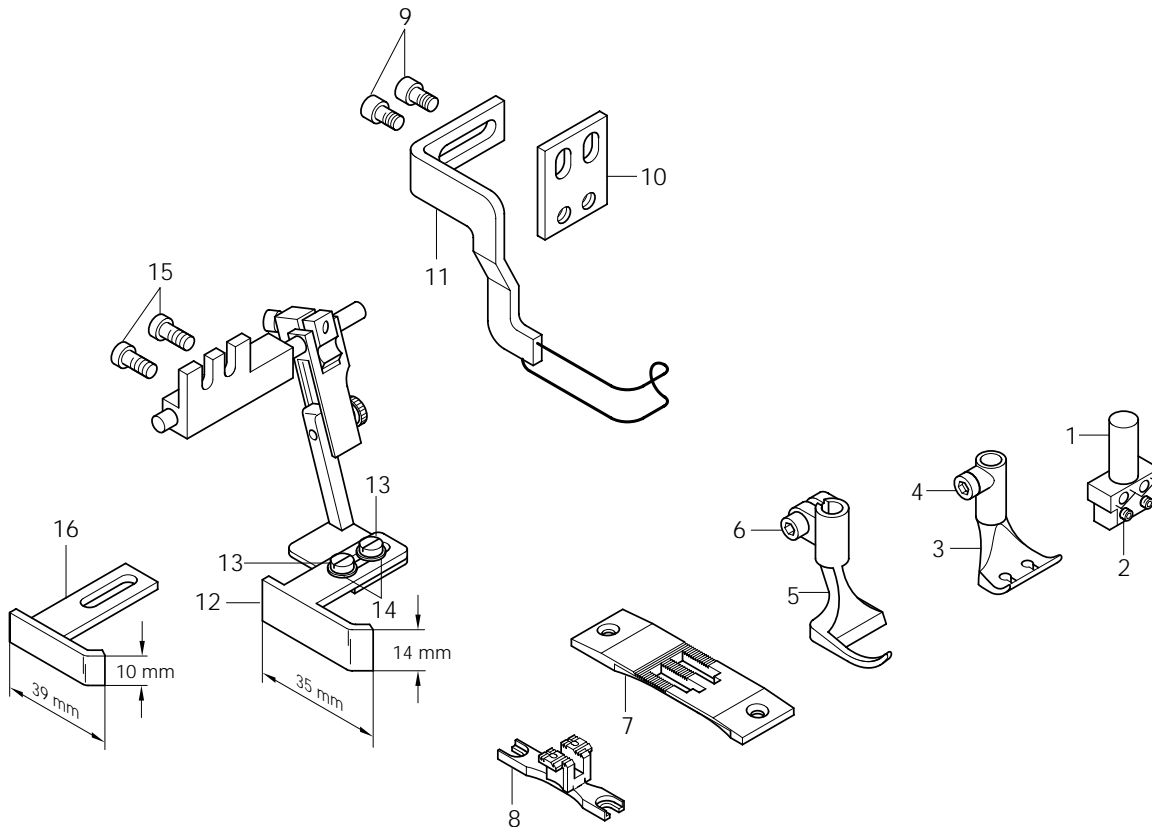

Pos.-Nr. Item No. N° pos. N° de pos.	Nadelabstand Needle gauge Ecartement de aiguilles Dist. entre aguja	Teile-Nr. Part No. N° de piezas N° de pieza
1 - 15	4,8	91-201 785-93/001
1 - 2	4,8	91-172 590-93/003
2		11-330 082-15
3 - 4	4,8	91-049 472-93/004
4		11-132 217-15
5 - 6	4,8	91-049 846-93/004
6		11-130 173-15
7	4,8	91-150 619-04/003
8	4,8	91-059 942-04/018
9 - 11		91-155 426-91

Pos.-Nr. Item No. N° pos. N° de pos.	Nadelabstand Needle gauge Ecartement de aiguilles Dist. entre aguja	Teile-Nr. Part No. N° de piezas N° de pieza
9		11-130 167-15
10		91-057 698-15
11		91-155 427-91
12 - 15		09-009 824-22
12		99-117 869-23
13		91-100 120-25
14		12-305 114-25
15		11-132 223-15
16		99-117 868-23



-6/01-900/81;/82 BN8♦

Für allgemeine Näharbeiten.  
 Standardform des Teilesatzes.

Für allgemeine Näharbeiten.  
 Standardform des Teilesatzes.

Für allgemeine Näharbeiten.  
 Standardform des Teilesatzes.

Für allgemeine Näharbeiten.  
 Standardform des Teilesatzes.

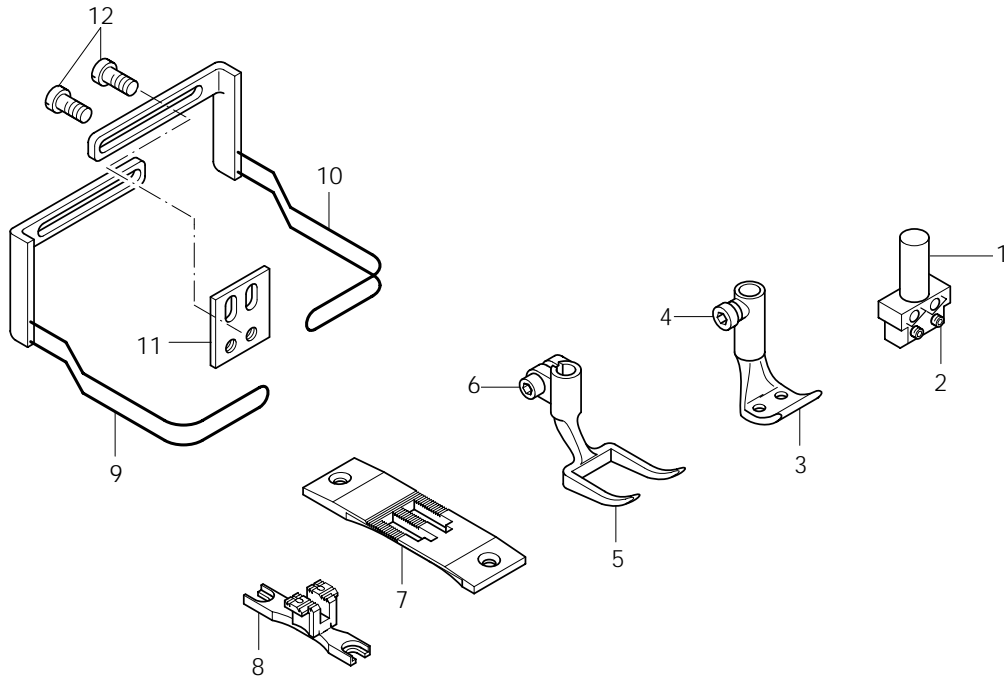

Pos.-Nr. Item No. N° pos. N° de pos.	Nadelabstand Needle gauge Ecartement de aiguilles Dist. entre aguja	Teile-Nr. Part No. N° de piezas N° de pieza
1 - 12	2,4 4,8 6,0 8,0 22,0	91-201 760-93/016 91-201 760-93/001 91-201 760-93/002 91-201 760-93/018 91-201 760-93/019
1 - 2	2,4 4,8 6,0 8,0 22,0	91-176 068-93/001 91-172 590-93/003 91-172 590-93/005 91-172 840-93/002 91-172 840-93/012
2		11-330 082-15
3 - 4	2,4 4,8 6,0 8,0 22,0	91-049 385-93/021 91-049 385-93/026 91-049 385-93/028 91-049 385-93/034 91-049 385-93/011
4		11-132 217-15
5 - 6	2,4 4,8 6,0 8,0 22,0	91-149 179-93/017 91-149 179-93/002 91-149 179-93/003 91-149 179-93/004 91-149 179-93/025
6		11-130 173-15
7	2,4	91-150 619-04/020

Pos.-Nr. Item No. N° pos. N° de pos.	Nadelabstand Needle gauge Ecartement de aiguilles Dist. entre aguja	Teile-Nr. Part No. N° de piezas N° de pieza
	4,8 6,0 8,0 22,0	91-150 619-04/002 91-150 619-04/001 91-150 619-04/005 91-150 619-04/009
8	2,4 4,8 6,0 8,0 22,0	91-059 942-04/015 91-059 942-04/002 91-059 942-04/003 91-059 942-04/019 91-059 942-04/027
9 - 12	2,4 4,8 6,0 8,0 22,0	91-154 696-91 91-154 699-91 91-154 699-91 91-154 699-91 91-154 706-91
9	2,4 4,8 6,0 8,0 22,0	91-154 697-91 91-154 700-91 91-154 700-91 91-154 700-91 91-154 707-91
10	4,8 6,0 8,0 22,0	91-154 703-91 91-154 703-91 91-154 703-91 91-154 709-91
11		91-057 698-15
12		11-108 174-15

-6/01-900/81;/82 CN8<sup>◆</sup>

Für allgemeine Näharbeiten.  
Standardform des Teilesatzes.

Für allgemeine Näharbeiten.  
Standardform des Teilesatzes.

Für allgemeine Näharbeiten.  
Standardform des Teilesatzes.

Für allgemeine Näharbeiten.  
Standardform des Teilesatzes.

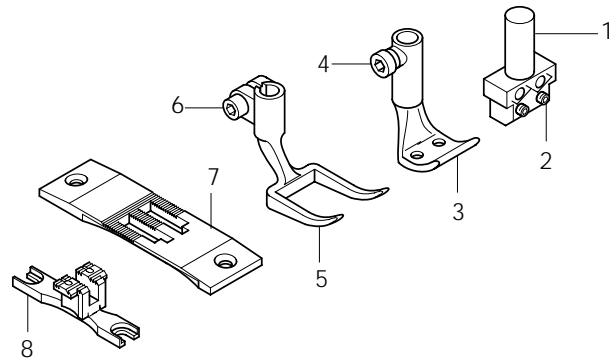
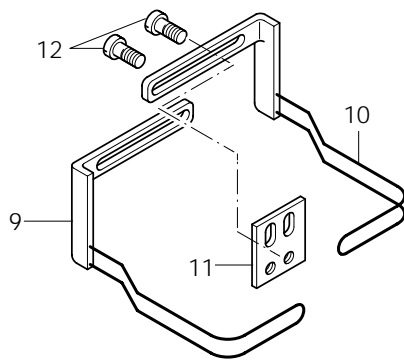

Pos.-Nr. Item No. N° pos. N° de pos.	Nadelabstand Needle gauge Ecartement de aiguilles Dist. entre aguja	Taille-Nr. Part No. N° de piezas N° de pieza
1 - 12	4,8 6,0 6,4 7,2 8,0 10,0 12,0 15,2 16,0 18,0 19,2 22,0 24,0	91-201 760-93/022 91-201 760-93/013 91-201 760-93/003 91-201 760-93/012 91-201 760-93/009 91-201 760-93/004 91-201 760-93/014 91-201 760-93/017 91-201 760-93/005 91-201 760-93/020 91-201 760-93/021 91-201 760-93/011 91-201 760-93/006
1 - 2	4,8 6,0 6,4 7,2 8,0 10,0 12,0 15,2 16,0 18,0 19,2 22,0 24,0	91-172 590-93/003 91-172 590-93/005 91-172 590-93/001 91-172 590-93/002 91-172 840-93/002 91-172 840-93/004 91-172 840-93/006 91-172 840-93/034 91-172 840-93/009 91-172 840-93/010 91-172 840-93/032 91-172 840-93/012 91-172 840-93/026
2		11-330 082-15
3 - 4	4,8 6,0 6,4 7,2 8,0 10,0 12,0 15,2 16,0 18,0 19,2 22,0 24,0	91-049 385-93/027 91-049 385-93/029 91-049 385-93/031 91-049 385-93/033 91-049 385-93/035 91-049 385-93/039 91-049 385-93/002 91-049 385-93/044 91-049 385-93/006 91-049 385-93/008 91-049 385-93/057 91-049 385-93/012 91-049 385-93/014
4		11-132 217-15
5 - 6	4,8 6,0; 6,4 7,2; 8,0 10,0 12,0 15,2 16,0	91-149 179-93/011 91-149 179-93/001 91-149 179-93/005 91-149 179-93/007 91-149 179-93/012 91-149 179-93/019 91-149 179-93/008

Pos.-Nr. Item No. N° pos. N° de pos.	Nadelabstand Needle gauge Ecartement de aiguilles Dist. entre aguja	Taille-Nr. Part No. N° de piezas N° de pieza
	18,0 19,2 22,0 24,0	91-149 179-93/020 91-149 179-93/021 91-149 179-93/009 91-149 179-93/010
6		11-130 173-15
7	4,8 6,0; 6,4 7,2; 8,0 10,0 12,0 15,2 16,0 18,0 19,2 22,0 24,0	91-150 619-04/003 91-150 619-04/004 91-150 619-04/005 91-150 619-04/007 91-150 619-04/019 91-150 619-04/021 91-150 619-04/008 91-150 619-04/023 91-150 619-04/024 91-150 619-04/009 91-150 619-04/010
8	4,8 6,0 6,4 7,2 8,0 10,0 12,0 15,2 16,0 18,0 19,2 22,0 24,0	91-059 942-04/018 91-059 942-04/001 91-059 942-04/004 91-059 942-04/005 91-059 942-04/006 91-059 942-04/007 91-059 942-04/013 91-059 942-04/016 91-059 942-04/008 91-059 942-04/021 91-059 942-04/022 91-059 942-04/009 91-059 942-04/010
9 - 12	4,8; 6,0; 6,4; 7,2; 8,0 10,0; 12,0; 15,2 16,0; 18,0; 19,2; 22,0; 24,0	91-154 699-91 91-154 706-91
9	4,8; 6,0; 6,4; 7,2; 8,0 10,0; 12,0; 15,2 16,0; 18,0; 19,2; 22,0; 24,0	91-154 700-91 91-154 707-91
10	4,8; 6,0; 6,4; 7,2; 8,0 10,0; 12,0; 15,2 16,0; 18,0; 19,2; 22,0; 24,0	91-154 703-91 91-154 709-91
11		91-057 698-15
12		11-108 174-15

-63/14-900/81;/82 CN8♦

Arbeitsgang  
Operation  
Opération  
Opéрация

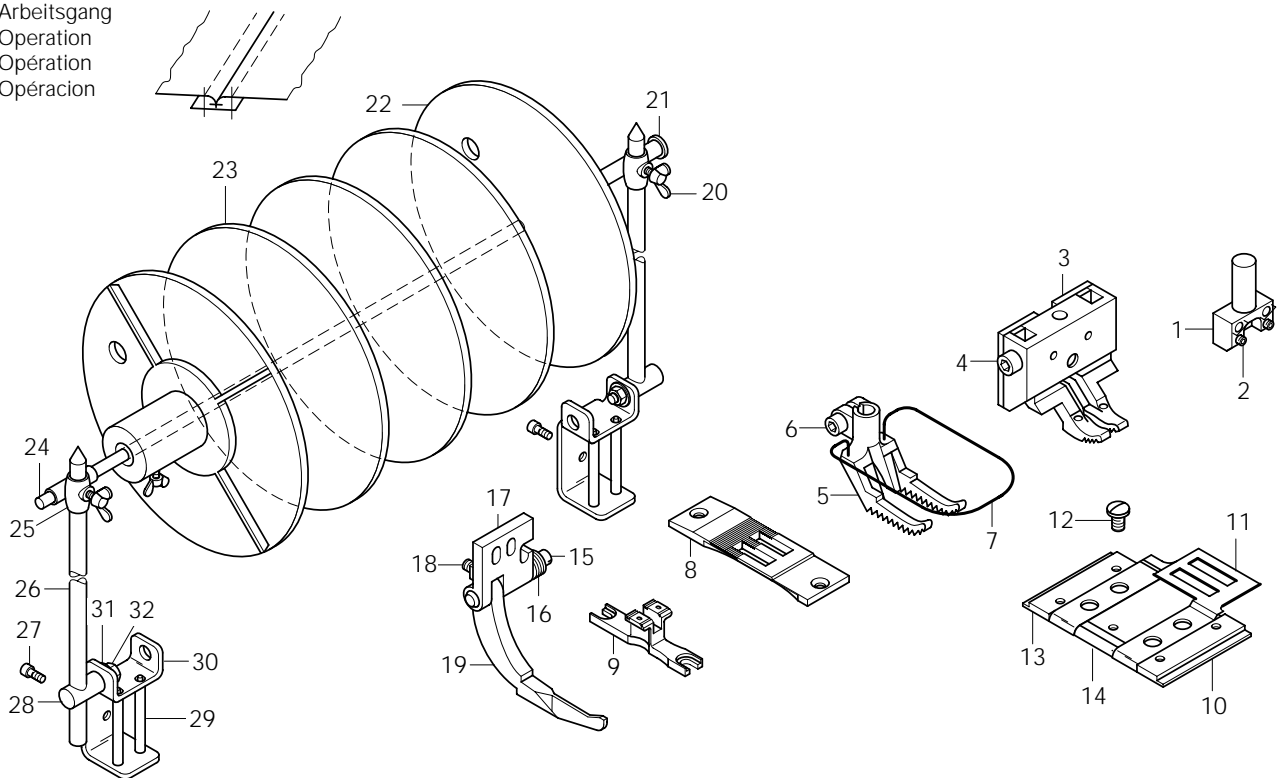

Pos.-Nr. Item No. N° pos. N° de pos.	Nadelabstand Needle gauge Ecartement de aiguilles Dist. entre aguja	Teile-Nr. Part No. N° de pièces N° de piezas
1 - 32	8,0 10,0 12,0 14,0	91-201 762-93/001 91-201 762-93/002 91-201 762-93/004 91-201 762-93/005
1 - 2	8,0 10,0 12,0 14,0	91-172 840-93/002 91-172 840-93/004 91-172 840-93/006 91-172 840-93/008
2		11-330 085-15
3 - 4	8,0 10,0 12,0 14,0	91-149 152-93/003 91-149 152-93/001 91-149 152-93/004 91-149 152-93/009
4		11-130 185-15
5 - 7	8,0 10,0 12,0 14,0	91-049 988-93/002 91-049 988-93/001 91-049 988-93/003 91-049 988-93/004
6		11-130 173-15
7		91-049 982-04/001 <span style="border: 1px solid black; padding: 0 2px;">3/1</span>
8	8,0 10,0 12,0 14,0	91-150 597-04/002 91-150 597-04/001 91-150 597-04/003 91-150 597-04/004
9	8,0 10,0	91-059 931-04/002 91-059 931-04/003

Pos.-Nr. Item No. N° pos. N° de pos.	Nadelabstand Needle gauge Ecartement de aiguilles Dist. entre aguja	Teile-Nr. Part No. N° de pièces N° de piezas
	12,0 14,0	91-059 931-04/004 91-059 931-04/005
10 - 14		91-156 679 -71/895
10		91-156 680-75/895
11		91-156 681-25
12		91-701 344-25
13		91-156 682-25
14		91-156 687-25
15 - 19		91-156 694-91
15		91-156 697-05
16		91-175 623-05
17		91-156 696-15
18		11-335 184-15
19		91-156 695-15
20 - 32		91-156 556-71/895
20		11-505 292-25
21		91-046 252-21
22		91-056 824-75/895
23		91-056 825-05
24		91-043 145-25
25		91-043 155-75/895
26		91-056 642-25
27		96-710 374-15
28		91-156 259-15
29		91-156 257-15
30		91-156 256-15
31		12-305 264-15
32		12-024 231-15

-230/21-900/81;/82 BN<sup>◆</sup>

Arbeitsgang  
 Operation  
 Opération  
 Operación

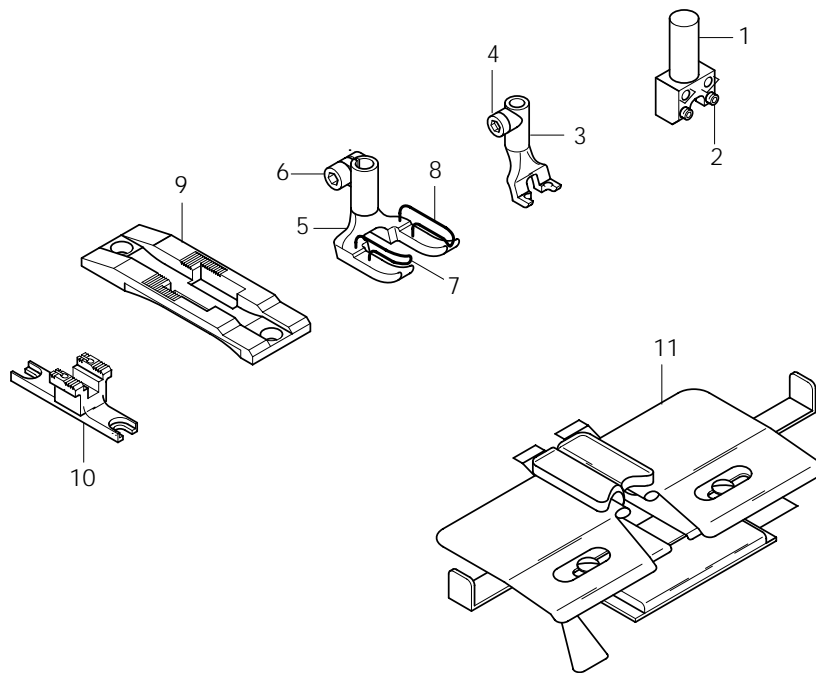
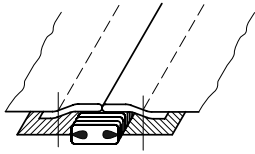

Pos.-Nr. Item No. N° pos. N° de pos.	Nadelabstand Needle gauge Ecartement de aiguilles Dist. entre aguja	Teile-Nr. Part No. N° de piezas N° de pieza
1 - 11	12,0	91-201 763-93/002
1 - 2	12,0	91-172 840-93/006
2		11-330 085-15
3 - 4	12,0	91-049 387-93/011
4		11-132 217-15
5 - 8	12,0	91-049 775-93/004

Pos.-Nr. Item No. N° pos. N° de pos.	Nadelabstand Needle gauge Ecartement de aiguilles Dist. entre aguja	Teile-Nr. Part No. N° de piezas N° de pieza
6		11-130 173-15
7		91-055 327-05 <span style="border: 1px solid black; padding: 0 2px;">3/1</span>
8		91-055 328-05 <span style="border: 1px solid black; padding: 0 2px;">3/1</span>
9		91-150 187-04/005
10		91-059 304-04/003
11		91-156 268-73/002

-230/21-900/81;/82 CN♦

Arbeitsgang  
 Operation  
 Opération  
 Operación

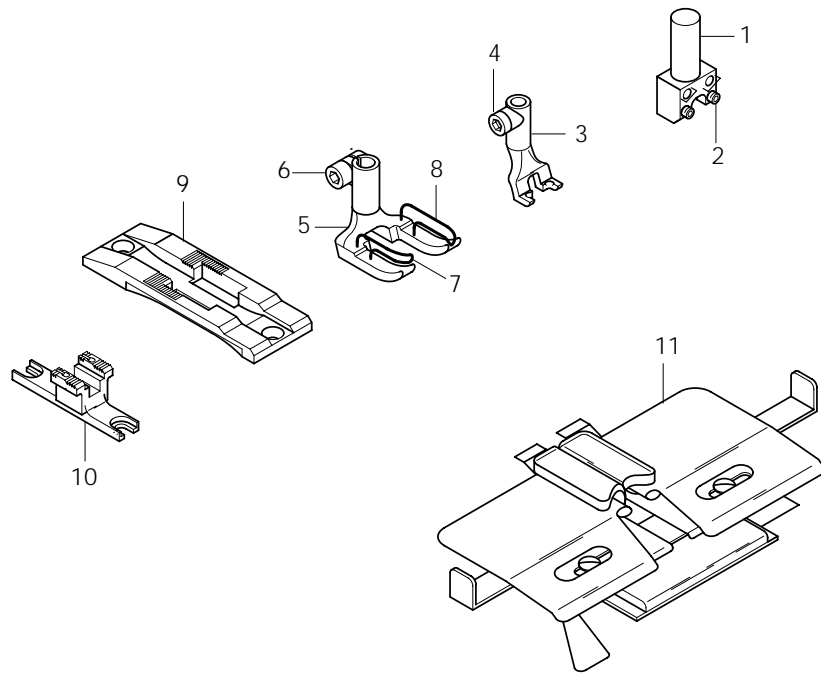
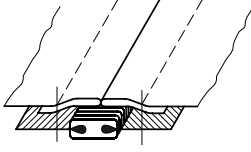

Pos.-Nr. Item No. N° pos. N° de pos.	Nadelabstand Needle gauge Ecartement de aiguilles Dist. entre aguja	Teile-Nr. Part No. N° de pièces N° de pieza
1 - 11	12,0	91-201 763-93/001
1 - 2	12,0	91-172 840-93/006
2		11-330 085-15
3 - 4	12,0	91-049 387-93/004
4		11-132 217-15
5 - 8	12,0	91-049 775-93/004

Pos.-Nr. Item No. N° pos. N° de pos.	Nadelabstand Needle gauge Ecartement de aiguilles Dist. entre aguja	Teile-Nr. Part No. N° de pièces N° de pieza
6		11-130 173-15
7		91-055 327-05 [3/1]
8		91-055 328-05 [3/1]
9		91-150 187-04/005
10		91-059 304-04/004
11		91-156 268-73/002

-237/06-900/81;/82 BN<sup>◆</sup>

Arbeitsgang  
 Operation  
 Opération  
 Operación

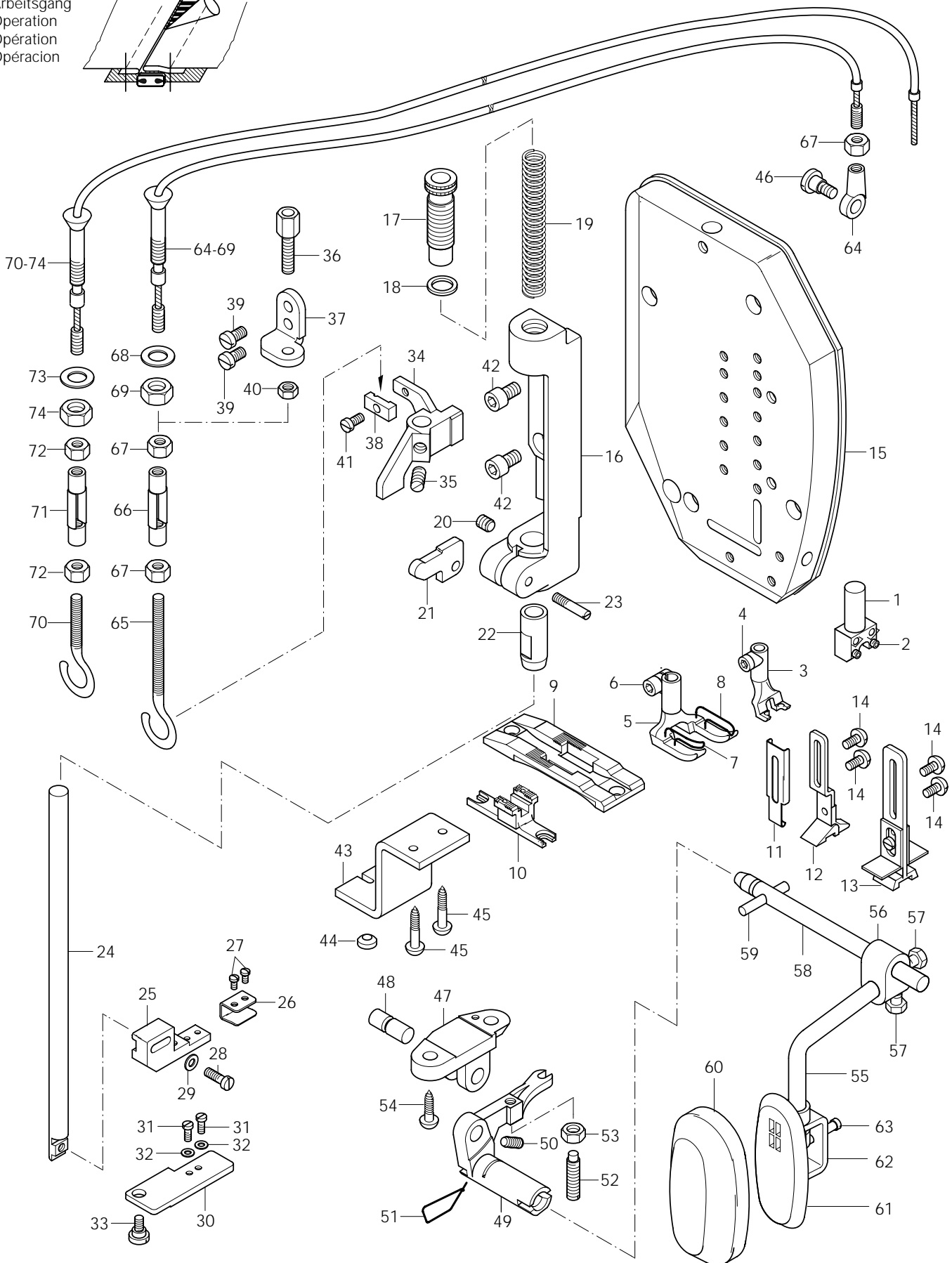
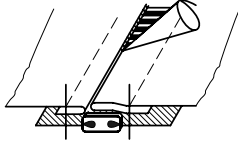

Pos.-Nr. Item No. N° pos. N° de pos.	Nadelabstand Needle gauge Ecartement de aiguilles Dist. entre aguja	Teile-Nr. Part No. N° de piezas N° de pieza	Pos.-Nr. Item No. N° pos. N° de pos.	Nadelabstand Needle gauge Ecartement de aiguilles Dist. entre aguja	Teile-Nr. Part No. N° de piezas N° de pieza
1 - 14	12,0	91-201 764-93/001	40		12-005 175-25
1 - 2	12,0	91-172 840-93/006	41		11-108 174-15
2		11-330 085-15	42		11-130 284-15
3 - 4	12,0	91-049 387-93/011	43 - 69		91-027 380-70
4		11-132 217-15	43		91-027 383-15
5 - 8	12,0	91-049 775-93/004	44		91-027 384-15
6		11-130 173-15	45		11-460 250-15
7		91-055 327-05 [3/1]	46		11-187 019-15
8		91-055 328-05 [3/1]	47 - 53		91-168 370-71/951
9		91-150 187-04/005	47		91-168 371-75/951
10		91-059 304-04/003	48		91-168 372-05
11		91-056 031-15	49		91-168 373-15
12		91-056 026-13/002	50		11-335 902-15
13		91-056 033-13/002	51		91-168 331-05
14		91-000 335-15	52		11-305 305-15
15 - 42		91-176 450-71/893	53		12-005 195-15
15		91-166 200-75/893	54		11-460 295-15
16		91-009 525-75/895	55 - 63		91-027 380-71/893
17		91-000 392-15	55		91-027 289-15
18		91-006 526-15	56 - 57		91-069 335-72/893
19		91-007 054-05	57		11-039 360-15
20		91-000 152-15	58		91-027 382-15
21		91-108 586-15	59		13-052 256-15
22		91-009 527-05	60		91-029 692-75/792
23		91-000 469-15	61		91-027 370-05
24		91-014 429-01	62 - 63		91-027 371-12
25		91-108 587-15	63		11-174 233-15
26		91-108 588-15	64 - 69		91-108 595-71/895
27		91-000 091-15	64		91-140 617-75/895
28		11-108 180-15	65		91-108 596-15
29		12-305 114-15	66		91-010 643-05
30		91-176 451-15	67		91-001 513-15
31		11-108 096-15	68		91-028 953-15
32		12-305 084-15	69		12-024 211-15
33		91-000 565-15	70 - 74		91-174 259-91
34		91-174 243-15	70		91-010 644-15
35		91-000 510-15	71		91-010 643-05
36		99-133 259-25	72		91-001 513-15
37		91-174 244-15	73		91-028 953-15
38		91-174 245-15	74		12-024 211-15
39		11-108 222-15			

-237/10-900/81;/82 BN♦

Arbeitsgang  
 Operation  
 Opération  
 Operación

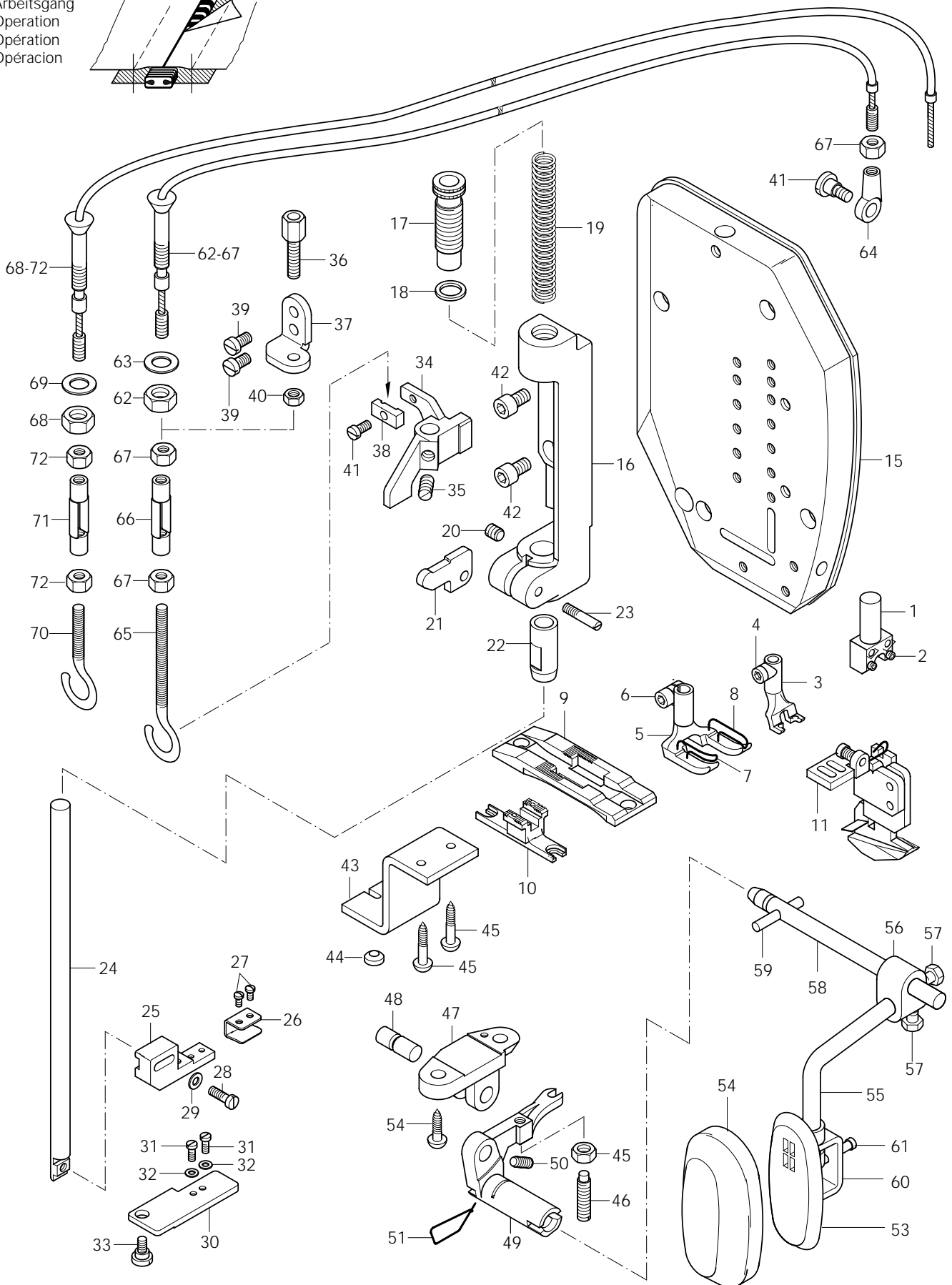
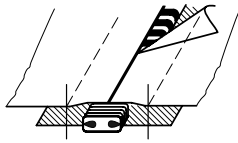



Pos.-Nr. Item No. N° pos. N° de pos.	Nadelnstand Needle gauge Ecartement de aiguilles Dist. entre aguja	Teile-Nr. Part No. N° de piezas N° de pieza
1 - 2	12,0	91-172 840-93/006
2		11-330 085-15
3 - 4	12,0	91-049 387-93/011
4		11-132 217-15
5 - 8	12,0	91-049 775-93/004
6		11-130 173-15
7		91-055 327-05 [3/1]
8		91-055 328-05 [3/1]
9		91-150 188-04/005
10		91-059 734-04/004
11		91-156 283-93
12 - 40		91-176 450-71/893
13		11-130 284-15
14		11-108 174-15
15		91-166 200-75/893
16		91-009 525-75/895
17		91-000 392-15
18		91-006 526-15
19		91-007 054-05
20		91-000 152-15
21		91-108 586-15
22		91-009 527-05
23		91-000 469-15
24		91-014 429-01
25		91-108 587-15
26		91-108 588-15
27		91-000 091-15
28		11-108 180-15
29		12-305 114-15
30		91-176 451-15
31		11-108 096-15
32		12-305 084-15
33		91-000 565-15
34		91-174 243-15
35		91-000 510-15
36		99-133 259-25
37		91-174 244-15
38		91-174 245-15
39		11-108 222-15
40		12-005 175-25

Pos.-Nr. Item No. N° pos. N° de pos.	Nadelnstand Needle gauge Ecartement de aiguilles Dist. entre aguja	Teile-Nr. Part No. N° de piezas N° de pieza
41 - 67		91-027 380-70
41		11-187 019-15
42		11-460 250-15
43		91-027 383-15
44		91-027 384-15
45 - 51		91-168 370-71/951
45		12-005 195-15
46		11-305 305-15
47		91-168 371-75/951
48		91-168 372-05
49		91-168 373-15
50		11-335 902-15
51		91-168 331-05
52		11-460 295-15
53 - 61		91-027 380-71/893
53		91-027 370-05
54		91-029 692-75/792
55		91-027 289-15
56 - 57		91-069 335-72/893
57		11-039 360-15
58		91-027 382-15
59		13-052 256-15
60 - 61		91-027 371-12
61		11-174 233-15
62 - 67		91-108 595-71/895
62		12-024 211-15
63		91-028 953-15
64		91-140 617-75/895
65		91-108 596-15
66		91-010 643-05
67		91-001 513-15
68 - 72		91-174 259-91
68		12-024 211-15
69		91-028 953-15
70		91-010 644-15
71		91-010 643-05
72		91-001 513-15

**PFAFF**