

KS/KH

EX3200, EX5200, EX5400, EXT3200,
EXT5200, LX3200, LX5200 Series

Parts Catalog

〈暫定版〉
Provisional issue



■このパーツカタログは、1995年11月現在のEX3200・EX5200・EX5400・EXT3200・EXT5200・LX3200・LX5200用のKS,KH装置を記載しています。

■部品を御注文いただくときは、必ず部品番号だけを明示して下さい。

■ This parts catalog covers KS,KH devices manufactured November, 1995 for EX3200・EX5200・EX5400 series, EXT3200・EXT5200 series, LX3200・LX5200 series.

■ Always give the part numbers when ordering parts.

目次

CONTENTS

KH 装置適用一覧

EX5200/KH	EX5400/KH	1
EX3200/KH		2
EXT5200/KH	EXT3200/KH	3
LX5200/KH	LX3200/KH	4

KH 装置構成部品一覧

KH 装置パーツイラスト&リスト

KH チェーンカッター (KH020)	6~7
KH チェーンカッター (KH021)	8~9

KS 装置適用一覧

EX5200/KS	EX5400/KS	10
EX3200/KS		11
EXT5200/KS	EXT3200/KS	12
LX5200/KS	LX3200/KS	13

KS 装置構成部品一覧

KS 装置パーツイラスト&リスト

KS テープカッター (KS371, 372, 373)	16~17
KS テープカッター (KS374, 375, 376)	18~19

Application table of KH

EX5200/KH	EX5400/KH	1
EX3200/KH		2
EXT5200/KH	EXT3200/KH	3
LX5200/KH	LX3200/KH	4

Component parts list for KH

Illustration & Parts list of KH

KH chain cutter (KH020)	6~7
KH chain cutter (KH021)	8~9

Application table of KS

EX5200/KS	EX5400/KS	10
EX3200/KS		11
EXT5200/KS	EXT3200/KS	12
LX5200/KS	LX3200/KS	13

Component parts list for KS

Illustration & Parts list of KS

KS chain cutter (KS371, 372, 373)	16~17
KS chain cutter (KS374, 375, 376)	18~19

特徴 Features

形式 Type	駆動方式 Driving system	操作方法 Operating system	備考 Remarks
KH020A	上メス台駆動 Upper knifeholder driven	-	標準 Standard
KH020C	上メス台駆動 Upper knifeholder driven	-	広縫巾用 For wide seam
KH020D	上メス台駆動 Upper knifeholder driven	-	サージング用 For serging
KH020E	上メス台駆動 Upper knifeholder driven	-	裾下(爪)仕縫い用 For toe closing
KH020H	上メス台駆動 Upper knifeholder driven	-	薄物用 For light weight fabrics

装置適用一覽
Application table of
EX5200/KH
EX5400/KH

地縫い(1本針) Plain seaming (1 - needle)

	KH 020A	KH 020C	KH 020D	KH 020E	KH 020H
EX5204 - 01/233					○
EX5204 - 02/233					○
EX5404 - 02/233					○

サージング Serging

	KH 020A	KH 020C	KH 020D	KH 020E	KH 020H
EX5203 - 22/233			○		
EX5204 - 24/445 - □ (445 - 8は不可)			○		
EX5214 - 24/445 - □×□ (445 - 3 × 5は不可)		○			

ヒダ取り Shirring

	KH 020A	KH 020C	KH 020D	KH 020E	KH 020H
EX5214 - 43/333			○		

地縫い(2本針) Plain seaming (2 - needle)

	KH 020A	KH 020C	KH 020D	KH 020E	KH 020H
EX5214 - 01/233					○
EX5214 - 03/333	○				
EX5214 - M03/333	○				
EX5214 - 03C3/333	○				
EX5214 - M03C3/333	○				

巻縫い、Turn-up/down hemming

	KH 020A	KH 020C	KH 020D	KH 020E	KH 020H
EX5204 - 32R1/223				○	
EX5204 - 32R2/223L				○	
EX5204 - 32R2/223				○	

	KH 020A	KH 020C	KH 020D	KH 020E	KH 020H

特徴 Features

形式 Type	駆動方式 Driving system	操作方法 Operating system	備考 Remarks
KH021A	上メス台駆動 Upper knifeholder driven	-	標準 Standard
KH021B	上メス台駆動 Upper knifeholder driven	-	厚物用 For heavy weight fabrics
KH021C	上メス台駆動 Upper knifeholder driven	-	広縫巾用 For wide seam
KH021H	上メス台駆動 Upper knifeholder driven	-	薄物用 For light weight fabrics

装置適用一覧
Application table of
EXT5200/KH
EXT3200/KH

EXT5200 地縫い Plain seaming

	KH 021A	KH 021B	KH 021C	KH 021H
EXT5204 - 02/233				○
EXT5214 - 03/333	○			
EXT5214 - M03/333	○			

EXT5200 ハイピング Piping

	KH 021A	KH 021B	KH 021C	KH 021H
EXT5214 - C3P1/333	○			
EXT5214 - C3P2/333	○			

EXT3200 地縫い Plain seaming

	KH 021A	KH 021B	KH 021C	KH 021H
EXT3216(15) - 02/233				○
EXT3216(15) - 03/233 - 3 x □				○
EXT3216(15) - 03/233 - 5 x □		○		
EXT3244 - 03/333				○
EXT3216(15) - 04/435K		○		
EXT3216(15)H - 05/535K		○		
EXT3244 - 04/435K		○		
EXT3244H - 05/535K		○		

EXT3200 ヒタ取り Shirring

	KH 021A	KH 021B	KH 021C	KH 021H
EXT3216(15) - 42/233 - 3 x □				○
EXT3216(15) - 42/233 - 5 x □				○

EXT5200 ヒタ取り Shirring

	KH 021A	KH 021B	KH 021C	KH 021H
EXT5214 - 43/333	○			

特徴 Features

形式 Type	駆動方式 Driving system	操作方法 Operating system	備考 Remarks
KH020A	上メス台駆動 Upper knifeholder driven	-	標準 Standard
KH020B	上メス台駆動 Upper knifeholder driven	-	厚物用 For heavy weight fabrics
KH020D	上メス台駆動 Upper knifeholder driven	-	サージング用 For serging
KH020E	上メス台駆動 Upper knifeholder driven	-	靴下(爪先縫い)用 For toe closing
KH020H	上メス台駆動 Upper knifeholder driven	-	薄物用 For light weight fabrics

装置適用一覧
Application table of
LX5200/KH
LX3200/KH

LX5200 地縫い、Plain seaming

	KH 020A	KH 020B	KH 020D	KH 020E	KH 020H
LX5204 - 01/223					○
LX5214 - 01/233					○
LX5204 - 02/233					○
LX5214 - 03/333			○		
LX5214 - M03/333			○		
LX5214 - 03C3/333			○		
LX5214 - M03C3/333			○		

LX5200 巻き縫い、Turn-up/down hemming

	KH 020A	KH 020B	KH 020D	KH 020E	KH 020H
LX5204 - 32R2/223L					○

LX5200 ヒタ取り Shirring

	KH 020A	KH 020B	KH 020D	KH 020E	KH 020H
LX5214 - 43/333	○				

LX5200 サージング Serging

	KH 020A	KH 020B	KH 020D	KH 020E	KH 020H
LX5203 - 22/233			○		

LX3200 地縫い、Plain seaming

	KH 020A	KH 020B	KH 020D	KH 020E	KH 020H
LX3216(15) - 01/222					○
LX3216(15) - 02/223					○
LX3216(15) - 02A/223					○
LX3216(15) - 03/233 - 3 × □					○
LX3216(15) - 03/233 - 5 × □			○		
LX3216(15) - 03/333 - 3 × □					○
LX3216(15) - 03/333 - 5 × □					○
LX3216(15) - 04/435				○	

LX3200 ヒタ取り Shirring

	KH 020A	KH 020B	KH 020D	KH 020E	KH 020H
LX3216(15) - 42/233 - 3 × □					○
LX3216(15) - 42/233 - 5 × □			○		

装置構成部品一覧表
Component parts list for KH

装置形式 Type	特徴 Features	チェーンカッター(組) Chain cutter complete		適用付帯装置 Equipment		
		チェーンカッター Chain cutter	布案内 Fabric guide	加圧装置+リントリカター Blower + Lint collector	H集塵器 H-dust collector	T集塵器 T-dust collector
KH020A	標準 Standard	308020A91Y	308022A			
KH020B	厚物用 For heavy weight fabrics	308020B91Y	308022B			
KH020C	広縫巾用 For wide seam	308020C91Y	308022C			
KH020D	サージ用 For serging	308020D91Y	308022D			
KH020E	靴下縫い(爪先縫い)用 For toe closing	308020E91Y	308022E		(100V) 304039	(100V) 304039C
KH020H	薄物用 For light weight fabrics	308020H91Y	308022H	ブローア分類表 参照 See the table for blowers	(200V) 304040	(200V) 304040C
KH021A	標準 Standard	308100A91Y	308106A			
KH021B	厚物用 For heavy weight fabrics	308100B91Y	308106B			
KH021C	広縫巾用 For wide seam	308100C91Y	308106C			
KH021H	薄物用 For light weight fabrics	308100H91Y	308106H			

注1) 縫い目形式512のミシンはKH装置を使用できません。

注2) 付帯装置にT集塵装置をご使用になる場合には、切り屑受け(308080-UA)を別途ご注文下さい。

Note:1) The machine producing stitch type 512 cannot apply the KH device.

Note:2) Order the waste chute (308080-UA) separately when using the T waste collector as an accessory.

ブローア分類表 (50Hz 地域向け)
Blowers (available for 50 Hz zone)

ブローア装置 Blower	相数 Phase	電圧 Voltage
500007	1	100V
500008	3	200V
500013	3	200V (強力型) (powerful type)
500015	3	380V
500009	1	220V
500017	1	240V

ブローア分類表 (60Hz 地域向け)
Blowers (available for 60 Hz zone)

ブローア装置 Blower	相数 Phase	電圧 Voltage
500005	1	100V
500006	3	200V
500006	3	220V

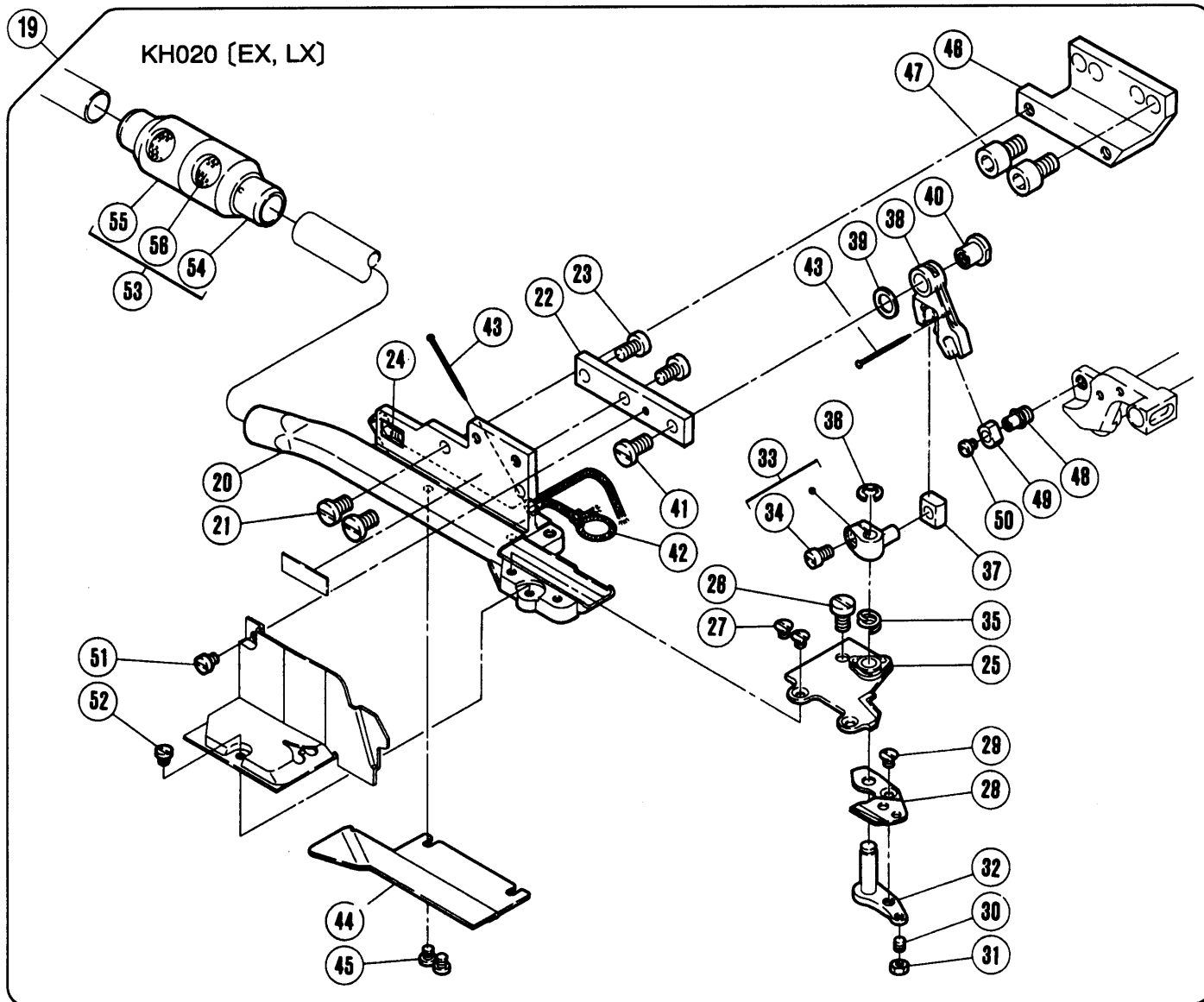
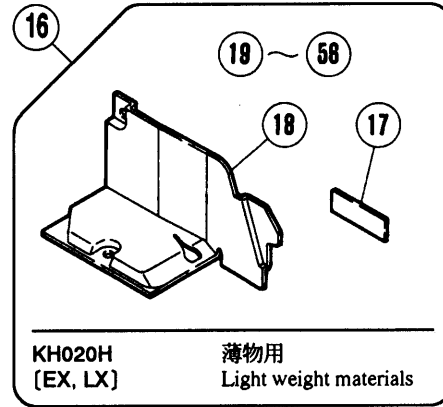
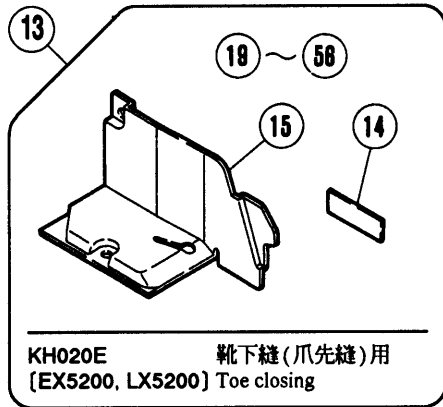
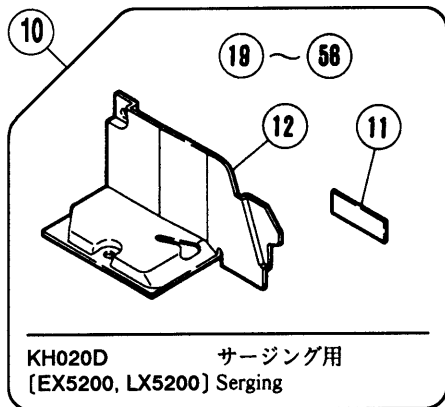
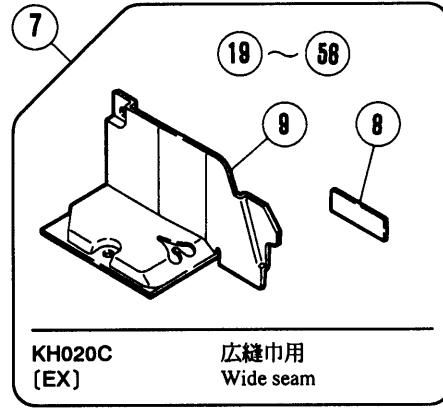
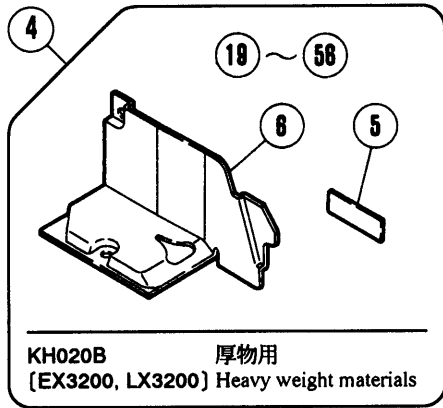
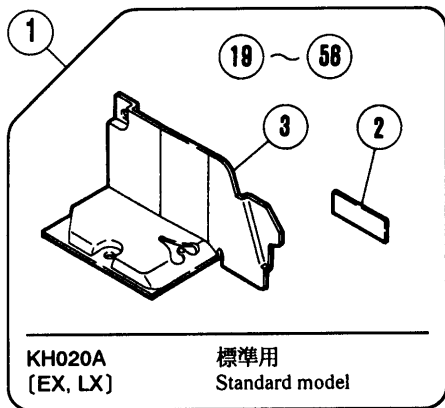

REF. NO.	PART NO. 部品番号	名称	NAME	QT.
01	308020A91Y	チェーンカッター (組)	CHAIN CUTTER COMPLETE	01
02	308065	銘板	NAME PLATE	01
03	308022A	布案内	FABRIC GUARD	01
04	308020B91Y	チェーンカッター (組)	CHAIN CUTTER COMPLETE	01
05	308066	銘板	NAME PLATE	01
06	308022B	布案内	FABRIC GUARD	01
07	308020C91Y	チェーンカッター (組)	CHAIN CUTTER COMPLETE	01
08	308067	銘板	NAME PLATE	01
09	308022C	布案内	FABRIC GUARD	01
10	308020D91Y	チェーンカッター (組)	CHAIN CUTTER COMPLETE	01
11	308068	銘板	NAME PLATE	01
12	308022D	布案内	FABRIC GUARD	01
13	308020E91Y	チェーンカッター (組)	CHAIN CUTTER COMPLETE	01
14	308069	銘板	NAME PLATE	01
15	308022E	布案内	FABRIC GUARD	01
16	308020H91Y	チェーンカッター (組)	CHAIN CUTTER COMPLETE	01
17	308071	銘板	NAME PLATE	01
18	308022H	布案内	FABRIC GUARD	01
19	308021A91	チェーンカッター (組)	CHAIN CUTTER COMPLETE	01
20	308023-91	フレームパイプ	FRAME PIPE	01
21	007063	平ネジ / M 4.5 × 8	SCREW	02
22	308032	ブラケット	BRACKET	01
23	007019	平ネジ / M 4 × 8	SCREW	02
24	008421	オイルマーク	OIL MARK	01
25	308026-91	上刃	UPPER KNIFE	01
26	007019	平ネジ / M 4 × 8	SCREW	01
27	007155	皿下ネジ / M 3 × 3.8	SCREW	02
28	308030	下刃	LOWER KNIFE	01
29	007155	皿ネジ / M 3 × 3.8	SCREW	01
30	004535	止皿ネジ / M 3 × 4	SCREW	01
31	004819	六角ナット / M 3	NUT	01
32	308029	レバー	LEVER	01
33	308031-92	クランク	CRANK	01
34	007012	平小ネジ / M 3.5 × 6	SCREW	01
35	240150	圧縮バネ	SPRING	01
36	201629	止メ輪	RING	01
37	179726-05	角駒	BLOCK	01
38	308034	レバー	LEVER	01
39	204115	座金	WASHER	01
40	179725-25	ブッシュ	BUSHING	01
41	007064	平ネジ / M 4.5 × 10	SCREW	01
42	202174	給油紐	OIL WICK	01
43	210766	止ピン	PIN	02
44	308033	補助板	AUXILIARY PLATE	01
45	007154	平ネジ / M 3 × 3.5	SCREW	02
46	308035	ブラケット	BRACKET	01
47	004518	六角穴ボルト / M 6 × 10	BOLT	02
48	308036	ネジ付	SCREW	01
49	304085	角駒	BLOCK	01
50	007078	平ネジ / M 2.5 × 3	SCREW	01
51	007008	平ネジ / M 3 × 5	SCREW	01
52	007154-HC	平ネジ / M 3 × 3.5	SCREW	01
53	301240	風量調節器 (組)	VACUUM REGULATOR COMPLETE	01
54	301236	風量調節器 (内)	VACUUM INNER REGULATOR	01
55	301237	風量調節器 (外)	VACUUM OUTER REGULATOR	02
56	301238	フィルター	FILTER/VACUUM REGULATOR	02

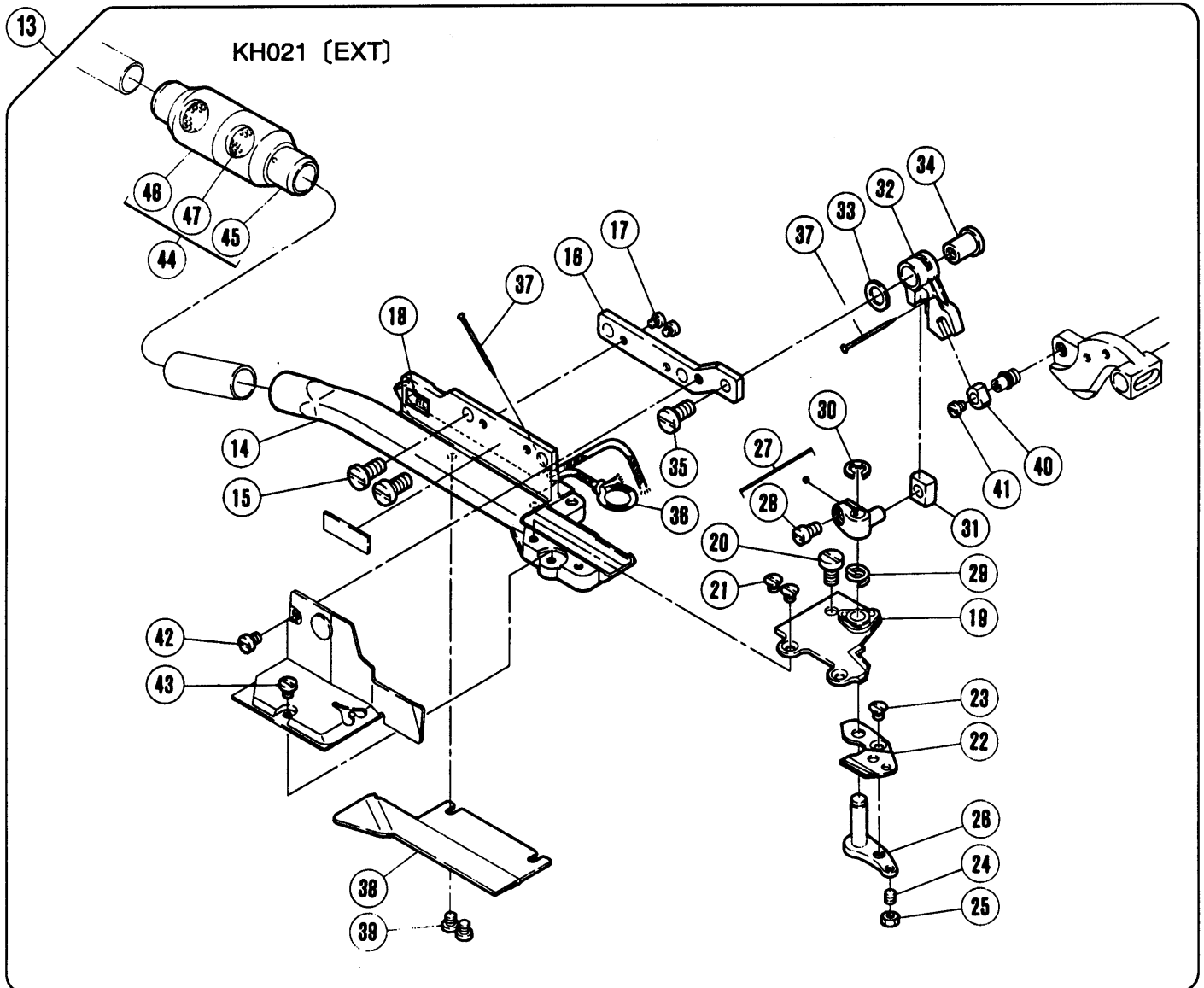
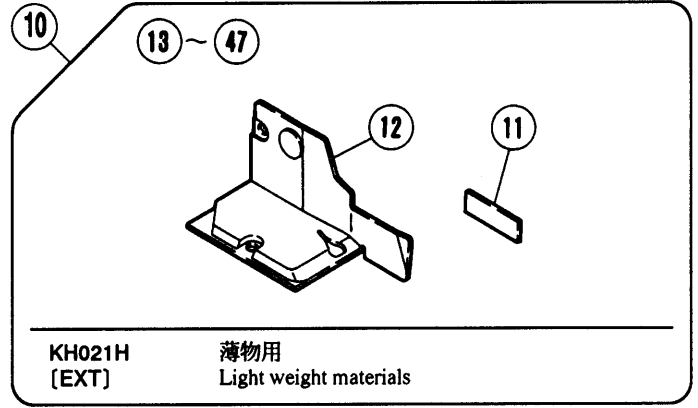
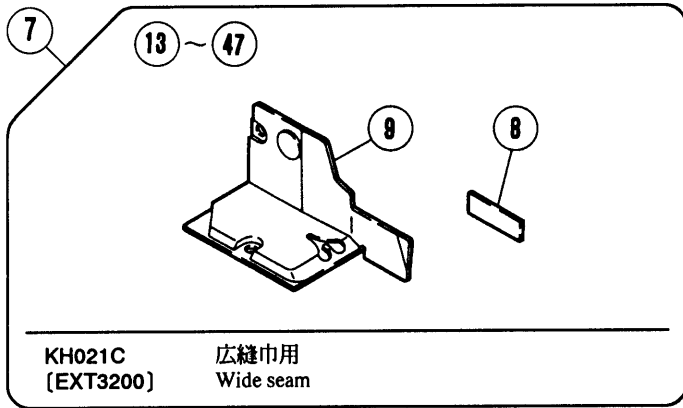
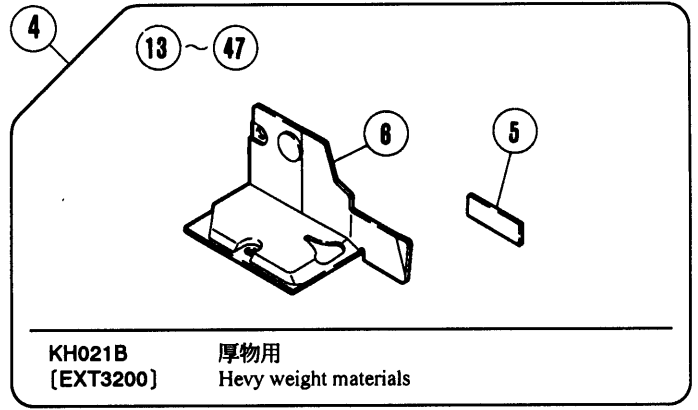
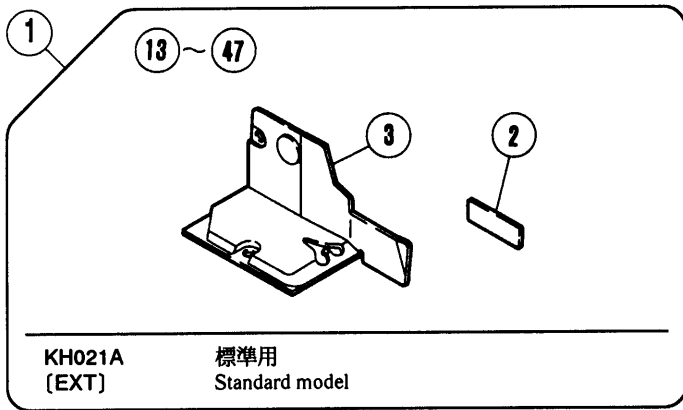

REF. NO.	PART NO. 部品番号	名称	NAME	QT.
01	308100A91Y	チェーンカッター (組)	CHAIN CUTTER COMPLETE	01
*02	308109	銘板	NAME PLATE	01
03	308106A	布案内	FABRIC GUARD	01
04	308100B91Y	チェーンカッター (組)	CHAIN CUTTER COMPLETE	01
*05	308110	銘板	NAME PLATE	01
06	308106B	布案内	FABRIC GUARD	01
07	308100C91Y	チェーンカッター (組)	CHAIN CUTTER COMPLETE	01
*08	308111	銘板	NAME PLATE	01
09	308106C	布案内	FABRIC GUARD	01
10	308100H91Y	チェーンカッター (組)	CHAIN CUTTER COMPLETE	01
11	308134	銘板	NAME PLATE	01
12	308106H	布案内	FABRIC GUARD	01
*13	308101A91	チェーンカッター (組)	CHAIN CUTTER COMPLETE	01
14	308023A91	フレームパイプ	FRAME PIPE	01
15	007064	平ネジ/M4.5×10	SCREW	02
16	308107	ブラケット	BRACKET	01
17	007078	平ネジ/M2.5×3	SCREW	02
18	008421	オイルマーク	OIL MARK	01
19	308026-91	上刃	UPPER KNIFE	01
20	007019	平ネジ/M4×8	SCREW	01
21	007155	皿ネジ/M3×3.8	SCREW	02
22	308030	下刃	LOWER KNIFE	01
23	007155	皿ネジ/M3×3.8	SCREW	01
24	004535	止ネジ/M3×4	SCREW	01
25	004819	六角ナット/M3	NUT	01
26	308029	レバー	LEVER	01
27	179731-92	クランク	CRANK	01
28	007012	平小ネジ/M3.5×6	SCREW	01
29	240150	圧縮バネ	SPRING	01
30	201629	止メ輪	RING	01
31	179726-05	角駒	BLOCK	01
32	308103	レバー	LEVER	01
33	204115	座金	WASHER	01
34	308108	ブッシュ	BUSHING	01
35	007064	平ネジ/M4.5×10	SCREW	01
36	202174	給油紐	OIL WICK	01
37	210766	止ピン	PIN	02
38	308033	補助板	AUXILIARY PLATE	01
39	007154	平ネジ/M3×3.5	SCREW	02
40	304085	角駒	BLOCK	01
41	007078	平ネジ/M2.5×3	SCREW	01
42	007008	平ネジ/M3×5	SCREW	01
43	007154-HC	平ネジ/M3×3.5	SCREW	01
44	301240	風量調節器 (組)	VACUUM REGULATOR COMPLETE	01
45	301236	風量調節器 (内)	VACUUM INNER REGULATOR	01
46	301237	風量調節器 (外)	VACUUM OUTER REGULATOR	02
47	301238	フィルタ	FILTER/VACUUM REGULATOR	02

装置適用一覧

Application table of EX5200/KS EX5400/KS

※表中の“○”印は推奨組み合わせ“△”印は準推奨組み合わせを表します。
“○” means the best combination while “△” the better.

特徴 Features

形式 Type	駆動方式 Driving system	操作方法 Operating system	備考 Remarks
KS371	上メス台駆動 Upper knifeholder driven	—	中吸い込み Middle suction type
KS372	上メス台駆動 Upper knifeholder driven	—	後吸い込み Rear suction type
KS373	上メス台駆動 Upper knifeholder driven	—	後吸い込み(吹付パイプ付) Rear suction type (with blower pipe)

地縫い(1本針) Plain seaming (1 - needle)

	KS371	KS372	KS373
EX5204 - 01/223	○	△	△
EX5204 - 02/233	○	△	△
EX5204 - 02H/223	○		
EX5404 - 02/233	○	△	△

裾引き Blindstitch hemming

	KS371	KS372	KS373
EX5205 - 12/223	○		
EX5203 - 12/223	○		

巻縫い Turn-up/down hemming

	KS371	KS372	KS373
EX5204 - 32R1/223		○	○
EX5204 - 32R2/223L		○	○
EX5204 - 32R2/223		○	○

地縫い(2本針) Plain seaming (2 - needle)

	KS371	KS372	KS373
EX5214 - 01/233		○	○
EX5214 - 03/333		○	○
EX5214 - M03/333		○	○
EX5214 - 03C3/333		○	○
EX5214 - M03C3/333		○	○

サージング Serging

	KS371	KS372	KS373
EX5203 - 22/233		○	○
EX5204 - 24/445 - □ (445 - 8 は不可)		○	○
EX5214 - 24/445 - □×□ (445 - 3 × 5 は不可)		○	○

ヒタ取り Shirring

	KS371	KS372	KS373
EX5214 - 43/333		○	○

多用途 Versatile

	KS371	KS372	KS373
EX5204 - 92M1/223		○	○
EX5214 - 92M2/223		○	○

特徴 Features

形式 Type	駆動方式 Driving system	操作方法 Operating system	備考 Remarks
KS374	上ノス台駆動 Upper knifeholder driven	-	中吸い込み Middle suction type
KS375	上ノス台駆動 Upper knifeholder driven	-	後吸い込み Rear suction type
KS376	上ノス台駆動 Upper knifeholder driven	-	後吸い込み吹付タイプ付 Rear suction type (with blower pipe)

装置適用一覧
Application table of
EXT5200/KS
EXT3200/KS

※表中の“○”印は推奨組み合わせ“△”印は準推奨組み合わせを表します。
“○” means the best combination while “△” the better.

EXT5200 地縫い Plain seaming

	KS 374	KS 375	KS 376
EXT5204 - 02/233	○	△	△
EXT5214 - 03/333		○	○
EXT5214 - M03/333		○	○

EXT5200 ヒダ取り Shirring

	KS 374	KS 375	KS 376
EXT5214 - 43/333		○	○

EXT3200 地縫い Plain seaming

	KS 374	KS 375	KS 376
EXT3216(15) - 02/223		○	○
EXT3216(15) - 03/233 - 3 x □		○	○

EXT3200 ヒダ取り Shirring

	KS 374	KS 375	KS 376
EXT3216(15) - 42/233 - 3 x □		○	○

EXT5200 裾引き Blindstitch hemming

	KS 374	KS 375	KS 376
EXT5205 - 12/223	○		

EXT5200 バイピング Piping

	KS 374	KS 375	KS 376
EXT5214 - C3P1/333		○	○
EXT5214 - C3P2/333		○	○

特徴 Features

形式 Type	駆動方式 Driving system	操作方法 Operating system	備考 Remarks
KS371	上ス台駆動 Upper knifeholder driven	-	中吸い込み Middle suction type
KS372	上ス台駆動 Upper knifeholder driven	-	後吸い込み Rear suction type
KS373	上ス台駆動 Upper knifeholder driven	-	後吸い込み吹付タイプ付 Rear suction type (with blower pipe)

装置適用一覧
Application table of LX5200/KS
LX3200/KS

※表中の“○”印は推奨組み合わせ“△”印は準推奨組み合わせを表します。
“○” means the best combination while “△” the better.

LX5200 地縫い Plain seaming

	KS 371	KS 372	KS 373
LX5204 - 01/223	○	△	△
LX5214 - 01/233			○
LX5204 - 02/233	○	△	△
LX5214 - 03/333			○
LX5214 - M03/333			○
LX5214 - 03C3/333			○
LX5214 - M03C3/333			○

LX5200 サージング Serging

	KS 371	KS 372	KS 373
LX5203 - 22/233		○	○

LX5200 巻き縫い Turn-up/down hemming

	KS 371	KS 372	KS 373
LX5204 - 32R2/223L		○	○

LX5200 裾引き Blindstitch hemming

	KS 371	KS 372	KS 373
LX5205 - 12/223	○		

LX5200 ヒダ取り Shirring

	KS 371	KS 372	KS 373
LX5214 - 43/333		○	○

LX3200 地縫い Plain seaming

	KS 371	KS 372	KS 373
LX3216(15) - 01/222		○	○
LX3216(15) - 02/223		○	○
LX3216(15) - 02A/223		○	○
LX3216(15) - 03/233 - 3 × □		○	○
LX3216(15) - 03/333 - 3 × □		○	○

LX3200 ヒダ取り Shirring

	KS 371	KS 372	KS 373
LX3216(15) - 42/233 - 3 × □		○	○

装置構成部品一覽表
Component parts list for **KS**

装置形式 Type	特徴 Features	チェーンカッター(組) Chain cutter complete	通用付帯装置 Equipment				
			加圧装置+(リントリカター) Blower + Lint collector	H集塵器 H-dust collector	T集塵器 T-dust collector	心カク(組)ON装置 (フィルター無) Venturi complete (ON device) without regulator	心カク(組)OQ装置 (フィルター付) Venturi complete (OQ device) with regulator
KS371	中吸い込み Middle suction type	308045 - 91Y	300305	(100V)304039 (200V)304040	(100V)304039C (200V)304040C	300464 - 91	300464A91
	後吸い込み Rear suction type	308046 - 91Y					
KS373	後吸い込み(吹付/パイプ付) Rear suction type (with blower pipe)	308047 - 91Y	-	-	-	-	-
	中吸い込み Middle suction type	308112 - 91Y	300305	(100V)304039 (200V)304040	(100V)304039C (200V)304040C	300464 - 91	300464A91
後吸い込み Rear suction type	308113 - 91Y						
KS376	後吸い込み(吹付/パイプ付) Rear suction type (with blower pipe)	308114 - 91Y	-	-	-	-	-

ブローワー分類表 (60Hz 地域向け)
Blowers (available for 60Hz zone)

ブローワー装置 Blower	相数 Phase	電圧 Voltage
500005	1	100V
500006	3	200V
500006	3	220V

ブローワー分類表 (50Hz 地域向け)
Blowers (available for 50Hz zone)

ブローワー装置 Blower	相数 Phase	電圧 Voltage
500007	1	100V
500008	3	200V
500013	3	200V (強力型) (powerful type)
500015	3	380V
500009	1	220V
500017	1	240V

注1) 付帯装置にT集塵装置をご使用になる場合には、切り屑受け (308080 - UA) を別途ご注文下さい。

Note:1) Order the waste chute (308080 - UA) separately when using the T waste collector as an accessory.

PEGASUS.

- 1 KS371
- 5 KS372

KS371 [EX5200, EX5400, LX5200]
 KS372 [EX, LX]

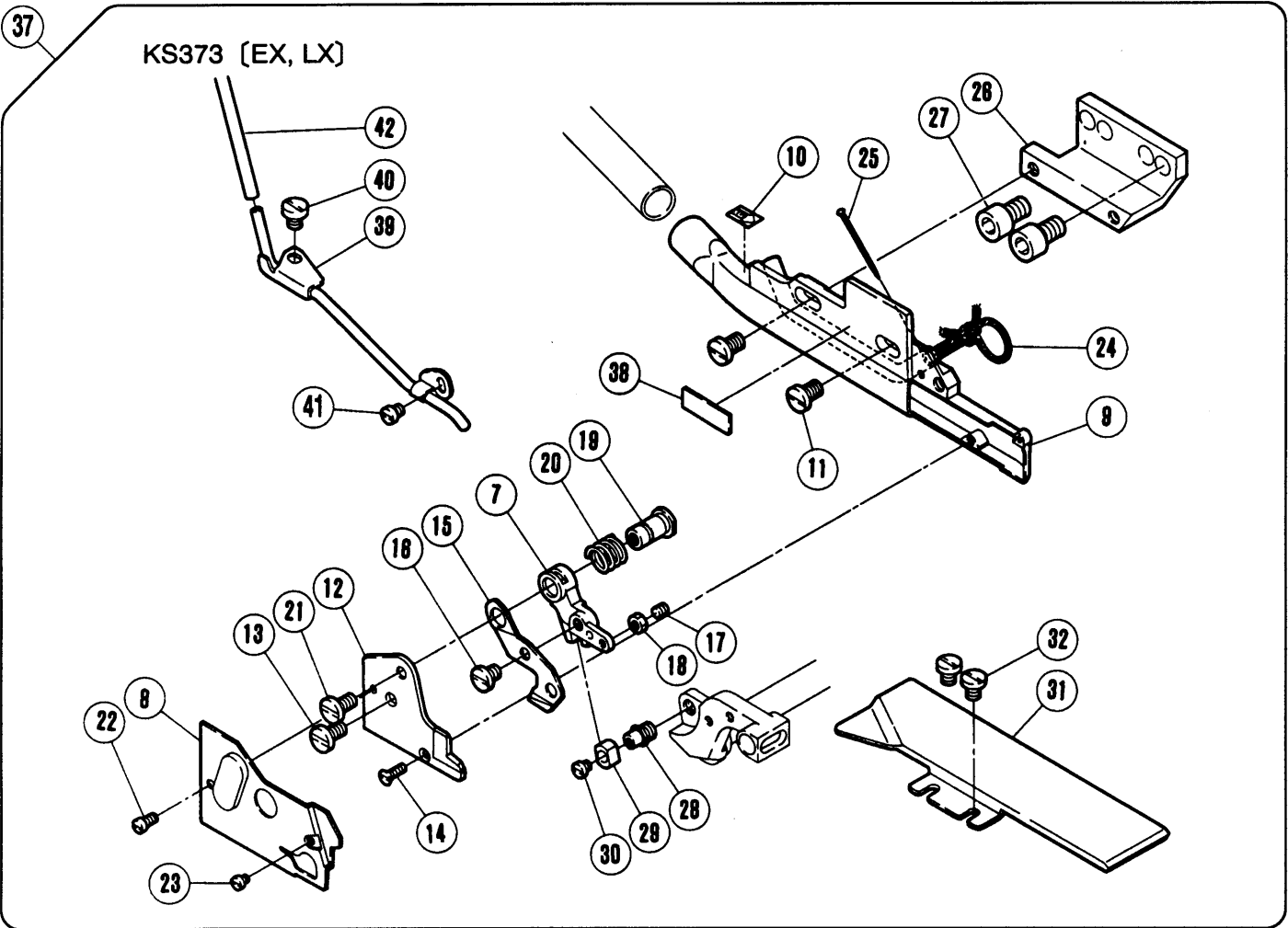
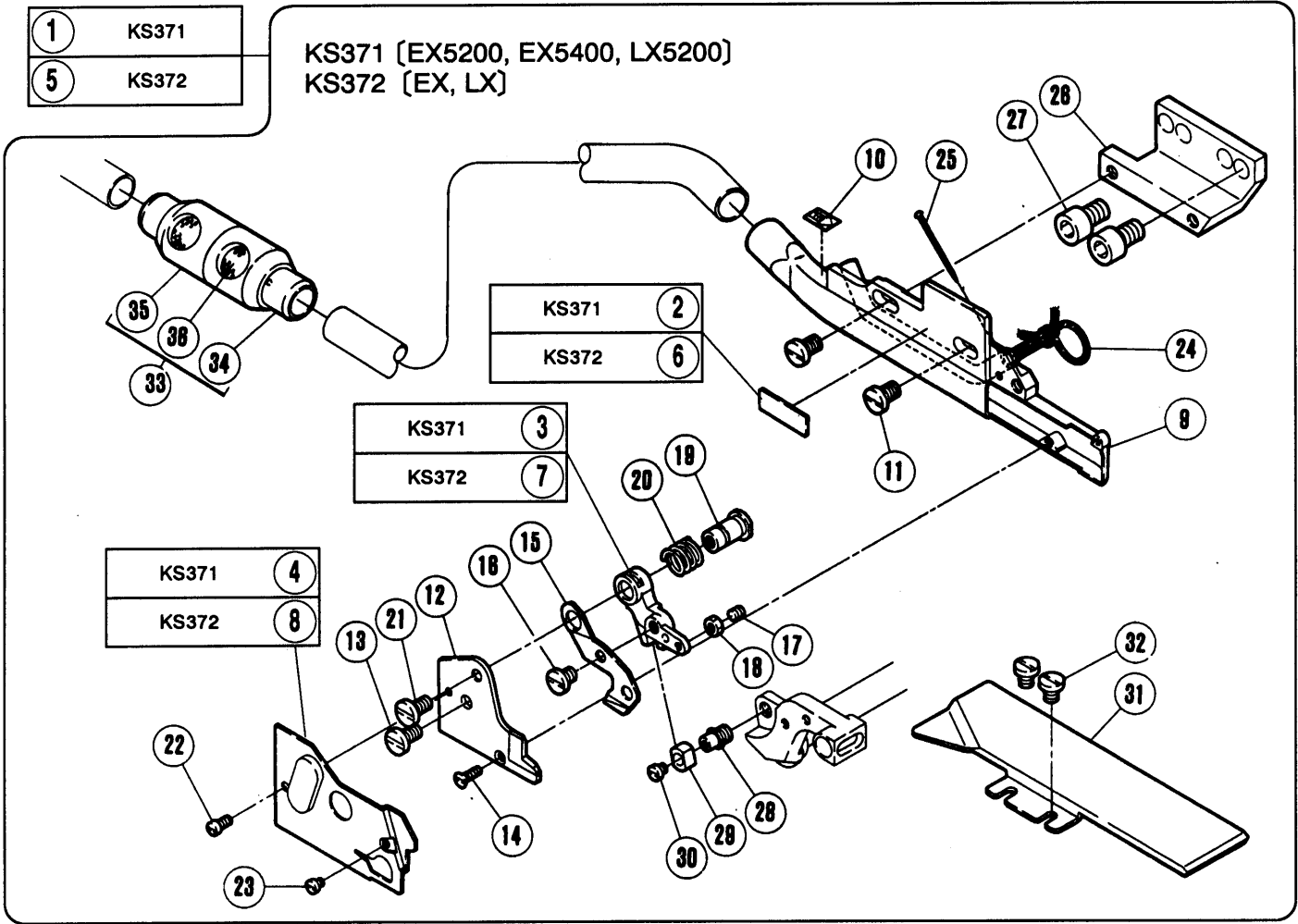

REF. NO.	PART NO. 部品番号	名称	NAME	QT.
*01	308045-91	チェーンカッター (組)	CHAIN CUTTER COMPLETE	01
02	308073	銘板	NAME PLATE	01
03	308055	レバー	LEVER	01
04	308058	布案内	FABRIC GUARD	01
*05	308046-91	チェーンカッター (組)	CHAIN CUTTER COMPLETE	01
06	308074	銘板	NAME PLATE	01
07	308056	レバー	LEVER	01
08	308059	布案内	FABRIC GUARD	01
09	308049-91	フレームパイプ	FRAME PIPE	01
10	008421	オイルマーク	OIL MARK	01
11	007063	平ネジ/M4.5×8	SCREW	02
12	179458-05	下刃 (静止刃)	LOWER KNIFE	01
13	007063	平ネジ/M4.5×8	SCREW	01
14	007039	皿ネジ/M2.5×6	SCREW	01
15	179459-05	上刃 (移動刃)	UPPER KNIFE	01
16	007143	平ネジ/M4×5.5	SCREW	01
17	004535	止ネジ/M3×4	SCREW	01
18	004819	六角ナット/M3	NUT	01
19	179460-25	ブッシュ	BUSHING	01
20	240053	圧縮バネ	SPRING	01
21	007063	平ネジ/M4.5×8	SCREW	01
22	007032	平ネジ/M2.5×6	SCREW	01
23	007120	平ネジ/M2×3	SCREW	01
24	202174	給油紐	OIL WICK	01
25	210766	止ピン	PIN	01
26	308035	ブラケット	BRACKET	01
27	004518	六角穴ボルト/M6×10	BOLT	02
28	308036	ピン付ネジ	SCREW	01
29	304085	角駒	BLOCK	01
30	007078	平ネジ/M2.5×3	SCREW	01
31	308060	補助板	AUXILIARY PLATE	01
32	007143	平ネジ/M4×5.5	SCREW	02
33	301240	風量調節器 (組)	VACUUM REGULATOR COMPLETE	01
34	301236	風量調節器 (内)	VACUUM INNER REGULATOR	01
35	301237	風量調節器 (外)	VACUUM OUTER REGULATOR	02
36	301238	フィルター	FILTER/VACUUM REGULATOR	02
*37	308047-91	チェーンカッター (組)	CHAIN CUTTER COMPLETE	01
38	308075	銘板	NAME PLATE	01
39	308063-91	吹付パイプ	PIPE/AIR BLOWER	01
40	007017	平ネジ/M4×5	SCREW	01
41	007008	平ネジ/M3×5	SCREW	01
42	303086	チューブ	TUBE	01

- | | |
|---|-------|
| 1 | KS374 |
| 5 | KS375 |

KS374 [EXT5200]
KS375 [EXT]

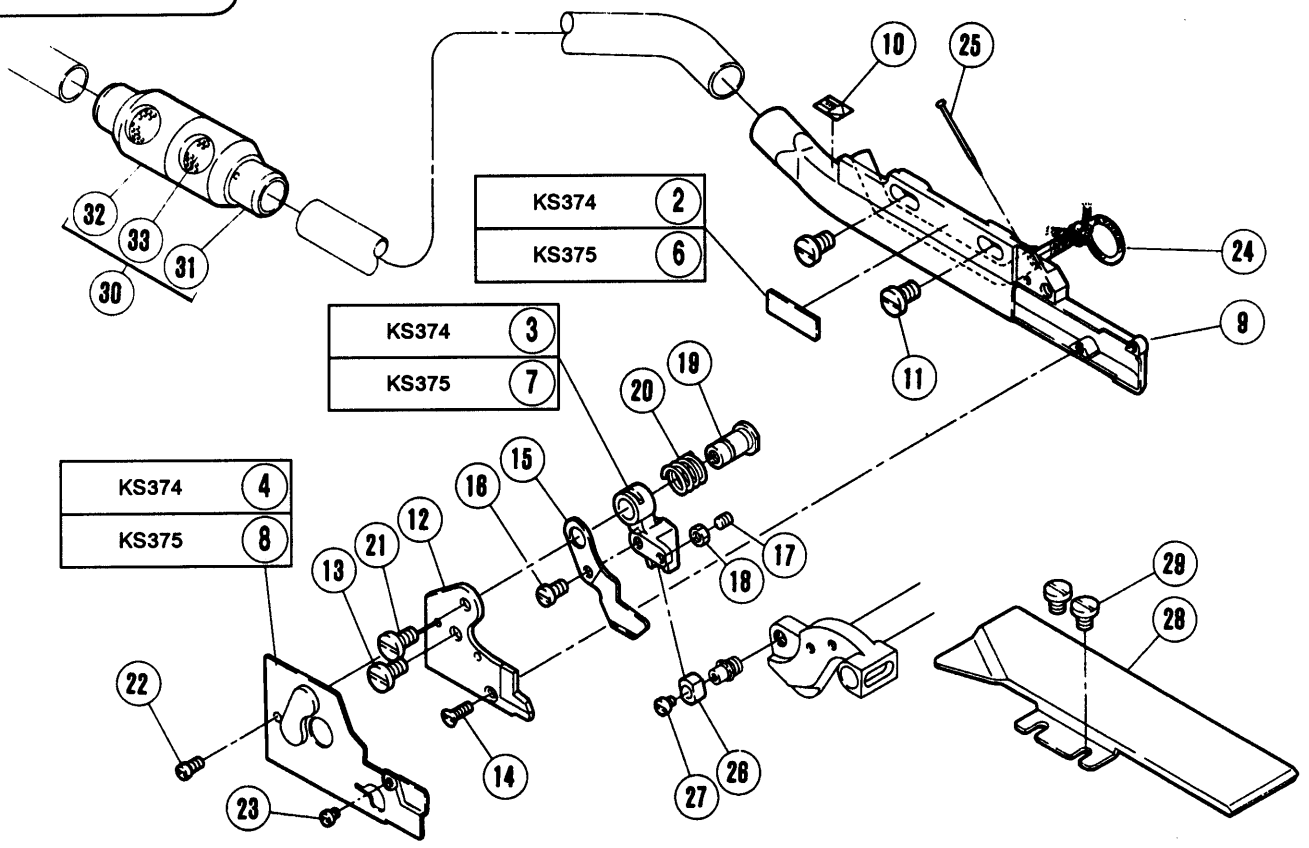

34

KS376 [EXT]

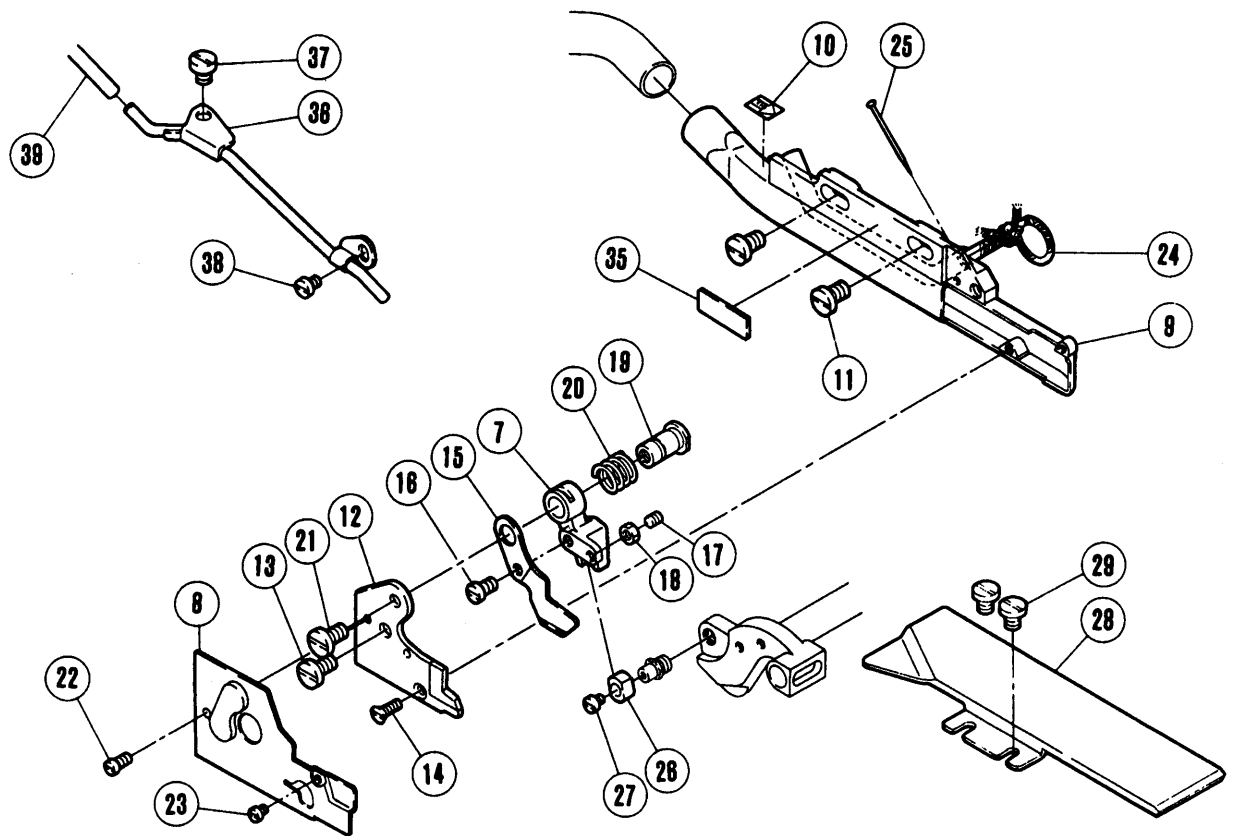

REF. NO.	PART NO. 部品番号	名称	NAME	QT.
※01	308112-91	チェーンカッター (組)	CHAIN CUTTER COMPLETE	01
※02	308123	銘板	NAME PLATE	01
03	308119	レバー	LEVER	01
04	308121	布案内	FABRIC GUARD	01
※05	308113-91	チェーンカッター (組)	CHAIN CUTTER COMPLETE	01
※06	308124	銘板	NAME PLATE	01
07	308120	レバー	LEVER	01
08	308122	布案内	FABRIC GUARD	01
※09	308115-91	フレームパイプ	FRAME PIPE	01
10	008421	オイルマーク	OIL MARK	01
11	007063	平ネジ/M4.5×8	SCREW	02
12	179458-05	下刃 (静止刃)	LOWER KNIFE	01
13	007063	平ネジ/M4.5×8	SCREW	01
14	007039	皿ネジ/M2.5×6	SCREW	01
15	308118	上刃 (移動刃)	UPPER KNIFE	01
16	007012	平小ネジ/M3.5×6	SCREW	01
17	004535	止ネジ/M3×4	SCREW	01
18	004819	六角ナット/M3	NUT	01
19	179460-25	ブッシュ	BUSHING	01
20	240053	圧縮バネ	SPRING	01
21	007063	平ネジ/M4.5×8	SCREW	01
22	007032	平ネジ/M2.5×6	SCREW	01
23	007120	平ネジ/M2×3	SCREW	01
24	202174	給油紐	OIL WICK	01
25	210766	止ピン	PIN	01
26	304085	角駒	BLOCK	01
27	007078	平ネジ/M2.5×3	SCREW	01
28	308060	補助板	AUXILIARY PLATE	01
29	007143	平ネジ/M4×5.5	SCREW	02
30	301240	風量調節器 (組)	VACUUM REGULATOR COMPLETE	01
31	301236	風量調節器 (内)	VACUUM INNER REGULATOR	01
32	301237	風量調節器 (外)	VACUUM OUTER REGULATOR	02
33	301238	フィルター	FILTER/VACUUM REGULATOR	02
※34	308114-91	チェーンカッター (組)	CHAIN CUTTER COMPLETE	01
※35	308125	銘板	NAME PLATE	01
36	308130-91	吹付パイプ	PIPE/AIR BLOWER	01
37	007017	平ネジ/M4×5	SCREW	01
38	007008	平ネジ/M3×5	SCREW	01
39	600096B	チューブ	TUBE	01

ペガサスミシン製造株式会社

本社 〒553 大阪市福島区鷹洲5-7-2 TEL (06) 458-4739
FAX (06) 454-8785

PEGASUS SEWING MACHINE MFG. CO., LTD.

5-7-2, Sagisu, Fukushima-ku, Osaka 553, Japan. Phone : (06) 458-4739
Telefax : (06) 454-8785

© August 1996 Cat. No.9732

Printed in Japan

本書に記載されている内容は、改良のため予告なく変更することがあります。
The description in this material is subject to change without notice.