

1295 1296

Teileliste

Parts list

Liste de pièces

Lista de piezas

Diese Teileliste hat für Maschinen ab nachfolgender
Seriennummer Gültigkeit:

This parts list applies to machines from the following
serial numbers onwards:

Cette liste de pièces est valable pour les machines au
numéros de série à partir de:

Esta lista de piezas tiene validez para máquinas a partir del
número de serie siguiente:

PFAFF 1295 # 2563518 →

PFAFF 1296 # 2563519 →

Alle Informationen und Abbildungen waren zum Zeitpunkt der Druckgebung auf dem neusten Stand.

Technische Änderungen vorbehalten!

Der Nachdruck, die Vervielfältigung sowie die Übersetzung - auch auszugsweise - aus PFAFF-Teilelisten ist nur mit unserer vorherigen Zustimmung und mit der Quellenangabe gestattet.

At the time of printing, all information and illustrations contained in this document were up to date.

Subject to alteration!

The reprinting, copying or translation of PFAFF Parts lists whether in whole or in part, is only permitted with our previous permission and with written reference to the source.

Au moment de la remise à l'imprimeur, toutes les informations et figures se rapportant à cette machine correspondaient à l'état actuel des connaissances.

Sous réserve de modifications techniques!

Aucune reproduction, polycopie ou traduction - même par extraits - des listes de pièces PFAFF ne peut être effectuée, à condition d'en indiquer l'origine, sans notre autorisation expresse.

Todas las informaciones e ilustraciones de este manual estaban al día en el momento de entregarse para su impresión.

¡ Salvo modificaciones técnicas!

La reimpresión, reproducción y traducción - aunque sólo sea parcial - de las listas de piezas PFAFF sólo está permitida con nuestro permiso previo e indicando la fuente.

**G.M. PFAFF KAISERSLAUTERN
INDUSTRIEMASCHINEN AG**

Postfach 3020
D-67653 Kaiserslautern

Königstr. 154
D-67655 Kaiserslautern

Redaktion/Illustration
Verlag Technische Dokumentation
Postfach 1106
D-77901 Lahr

		Seite Page Page Página
0	Wichtiger Hinweis Important note Avis important Observación importante	0 - 1
1	Vorwort Foreword Avant-propos Notas preliminares	1 - 1
2	Erläuterungen der Schlüsselzeichen Explanation of key markings Explication des symboles Explicaciones de los signos clave	2 - 1
3	Basismaschine Basic machine Machine de base Máquina básicas	
3.01	Gehäuseteile Housing sections Parties du corps Piezas del cárter	3 - 1
3.02	Kopfteile Needle head parts Pièces de tête Piezas de la cabeza	3 - 2
3.03	Armteile Arm parts Pièces de bras Piezas del brazo	3 - 7
3.04	Grundplattenteile Bedplate parts Pièces du plateau fondamental Piezas del cárter	3 - 10
4	Fadenabschneid-Einrichtung (-900/56) Thread trimmer (-900/56) Coupe-fil (-900/56) Cortahilos (-900/56)	4 - 1

		Seite Page Page Página
5	Nähfuß heben über Pedal (-910/01) Raiser presser foot via the pedal (-910/01) Relever le pied presseur en actionnant la pédale (-910/01) Elevación del prensatelas mediante pedal (-910/01)	5 - 1
6	Presserfuß-Automatik (-910/98) Automatic presser foot lifter (-910/98) Relève-pied automatique (-910/98) Alzaprensatelas (-910/98)	6 - 1
7	Verriegelungs-Einrichtung (-911/97) Backtacking mechanism (-911/97) Dispositif à points d'arrêt (-911/97) Rematador (-911/97)	7 - 1
8	Wartungseinheit (-925/03) Air filter / lubricator (-925/03) Conditionneur d'air comprimé (-925/03) Grupo acondicionador del aire comprimido (-925/03)	8 - 1
9	Einrichtung zum Nähen gewölbter Arbeitsstücke (-940/01) Equipment for sewing tubular workpieces (-940/01) Dispositif pour la couture ou le piquage d'articles bombes (-940/01) Equipo para coser piezas abombadas (-940/01)	9 - 1
10	Garnrollenständer Reel stands Porte-bobines Portacarretes	10 - 1
11	Einstellehren Adjustment gauges Calibres Calibres de ajuste	11 - 1
12	Teile zur Tischplatte Parts for table top Pièces du plateau Piezas para el tablero	11 - 1
13	Fadenöler Thread lubricator Graisseur de fil Lubricador del hilo	13 - 1

		Seite Page Page Página
14	Keilriemen V-belt Courroie trapèzoidale Correatrapezoidal	13 - 1
15	Keilriemenschutz (unter der Tischplatte) Belt guard (under table top) Garde-courroie (sous le plateau de table) Guardacorreas (parte inferior)	15 - 1
16	Knielüfterteile Knee lifter parts Pièces du releveur de genouillère Piezas del alzaprensateles por rodillera	16 - 1
17	Schmiermittel-Übersicht Overview of lubricants Tableau de lubrifiants Tabla de lubricantes	17 - 1
18	Index (Teilenummern / Seitenzahlen) Index (part numbers / page numbers) Index (numéros de pièces, de pages) Index (números de pieza / números de página)	18 - 1
19	Unterklassen-Ausstattung Subclass parts Composition des sous-classes Composición de las subclases	
19.01	Nähwerkzeuge (PFAFF 1295) Gauge parts (PFAFF 1295) Organes de couture (PFAFF 1295) Organos de costura (PFAFF 1295)	19 - 2
19.02	Nähwerkzeuge (PFAFF 1296) Gauge parts (PFAFF 1296) Organes de couture (PFAFF 1296) Organos de costura (PFAFF 1296)	19 - 5



Achtung!



Wir machen ausdrücklich darauf aufmerksam, daß Ersatz- und Zubehörteile, die nicht von uns geliefert werden, auch nicht von uns geprüft und freigegeben sind. Der Einbau und / oder die Verwendung solcher Produkte kann daher u. Umständen konstruktiv vorgegebene Eigenschaften Ihrer Maschine negativ verändern. Für Schäden, die durch die Verwendung von Nicht-Originalteilen entstehen, übernehmen wir keine Haftung!

Caution!



We warn you expressively that spare parts and accessories that are not supplied by us are not tested and released by us. Fitting or using these products may therefore have negative influences on features that depend on the machine design. We are not liable for any damage caused by the use of non-Pfaff parts!

Attention!



Nous attirons expressément votre attention sur le fait que les pièces de rechange et accessoires qui n'ont pas été livrés par nous n'ont pas non plus été contrôlés et agréés par nous. C'est pourquoi le montage et/ou l'utilisation de telles pièces peut éventuellement entraîner l'altération des caractéristiques de construction de votre machine. Par conséquent, nous n'assumons aucune responsabilité pour les dommages causés par l'emploi de pièces qui ne sont pas d'origine!

¡Atención!



Se hace observar que en el caso de piezas de recambio y accesorios que no hayan sido suministrados por nosotros, quiere decir que non han sido sometidas por nuestra parte a un control y que no se les ha dado el visto bueno. Por esta razón, el montaje y/o empleo de tales productos puede repercutir negativamente en las características previstas en su máquina. ¡Para los daños que eventualmente pudiesen presentarse al utilizar piezas no originales, no asumimos ninguna garantía!

- Die Seriennummer der Maschine, für die diese Teileliste Gültigkeit hat, ist auf der Titelseite aufgeführt.
 - Alle Teile sind so abgebildet, wie sie in der Maschine funktionsmäßig zusammengehören.
 - Gestrichelt dargestellte Teile zeigen angrenzende Teile aus anderen Funktionsgruppen.
 - Im oberen Teil der Bildseiten befindet sich eine Gesamtansicht der Maschine .
 - Der Einbauort der dargestellten Teile wird durch eine gerasterte Fläche gekennzeichnet.
 - Einrahmungen auf den Bildseiten zeigen, aus welchen Einzelteilen sich die Gruppenteile zusammensetzen.
 - Die auf den Bildseiten verwendeten Schlüsselzeichen (; 2 ; 3 usw.) sind im Kapitel "Erläuterungen der Schlüsselzeichen" aufgelistet.
-
- The serial number of the machine to which this parts list applies is indicated on the cover page.
 - All parts are illustrated in function groups with the parts which they function together with in the machine.
 - Parts illustrated with broken lines are parts from other function groups which border on the illustrated function group.
 - The above section of the page of illustrations contains a total view of the machine. The place for the installation of the parts pictured here is marked by the grid.
 - The framed-in sections on the illustration pages show the individual parts comprising a group.
 - The key markings used on the illustrated pages (; 2 ; 3 etc.) are listed in the chapter "Explanation of key markings".
-
- Le numéro de série de la machine pour laquelle cette liste de pièces est valable est indiqué sur la première page.
 - Toutes les pièces sont représentées en fonction de leur groupement fonctionnel dans la machine.
 - Les pièces hâchurées indiquent les pièces limitrophes de groupes de fonctions différents.
 - La partie supérieure des pages de figures comprend une présentation globale de la machine. L'emplacement des pièces représentées est signalé par quadrillages.
 - Les parties encadrées sur les pages à illustrations représentent les pièces individuelles formant groupe.
 - Vous trouverez au chapitre "Explication des symboles" une liste des symboles utilisés sur les pages de figures (; 2 ; 3 etc.)
-
- El número de serie de la máquina para la cual tiene validez esta lista de piezas va indicado en la página de título.
 - Todas las piezas están ilustradas tal como aparecen en la máquina para su funcionamiento.
 - Las piezas representadas con rayitas muestran piezas colindantes de otros grupos de funciones.
 - En la parte superior de las páginas ilustradas se puede ver una vista en conjunto de la máquina.
 - El lugar de montaje de la pieza representada va caracterizada mediante una superficie reticulada.
 - Los recuadros en las páginas ilustradas indican las piezas individuales de que se componen los grupos.
 - Los signos clave (; 2 ; 3 etc.) empleados en las páginas con ilustraciones van listados en el capítulo "Explicaciones de los signos clave".

- Unterklassenabhängig, Teilenummer siehe Unterklassen-Ausstattung.
Subclas-dependent, for part number see subclass parts listing.
Fonction de la sous-classe; pour le numéro de la pièce, voir "Equipement de sous-classes".
Dependientes de la subclase, para el número de pieza véase "Dotación de subclases".
- B Maschinen-Ausstattung für mittlere Materialien.
Model B for sewing thin and medium-weight materials.
Modèle B pour la couture de matières moyennes.
Tipo B para materiales semiligeros.
- C Maschinen-Ausstattung für mittelschwere Materialien.
Model C for sewing medium-heavy materials.
Modèle C pour la couture de matières mi-lourdes.
Tipo C para materiales semipesados.
- N Stichlänge 6,0 mm
Stitch length 6.0 mm
Longueur du point 6,0 mm
Largo de puntada 6,0 mm
- P Teile zum Hüpftransport
Components of four-motion drop feed.
Pièces de l'entraînement par griffe sautillante.
Piezas del transportador inferior a cuatro tiempos.
- 3 Geklebt
Part cemented
Pièce collée
Pieza pegada
- 5 Nähmuster bzw. Material einsenden.
Submit sewing sample or material.
Joindre échantillons de couture ou matières.
Envíense muestras de costura.
- 6 Nadeldicke und Spitzenform bei Bestellung angeben.
Needle size and style of point to be stated on order.
Préciser la grosseur de l'aiguille et la forme de la pointe à la commande.
Grosor de aguja y forma de la punta, indíquese en los pedidos.
- 27/2 Eingeklammerte Zahl = Dicke in mm.
Number in brackets = thickness in mm.
Chiffre entre parenthèses = épaisseur en mm.
Cifra entre paréntesis = espesor en mm.
- 27/5 Eingeklammerte Zahl = Länge in mm.
Number in brackets = length in mm.
Chiffre entre parenthèses = longueur en mm.
Cifra entre paréntesis = largura en mm.
- 28 Sonderausführung
Special version
Version spéciale
Tipo especial

- 40/2 Tränken mit 28-011 201-44; Bestellnummer siehe Seite 17 - 1.
Soak with 28-011 201-44; for part number see page 17 - 1.
Imbiber d'huile 28-011 201-44; n° de commande, voir page 17 - 1.
Empage con aceite 28-011 201-44; para el número de pedido véase la página 17 - 1.
- 40/3 Fetten mit 28-011 202-47; Bestellnummer siehe Seite 17 - 1.
Grease with 28-011 202-47; for part number see page 17 - 1.
Graisser avec de la graisse 28-011 202-47; n° de commande, voir page 17 - 1.
Engrase con grasa 28-011 202-47; para el número de pedido véase la página 17 - 1.
- 40/4 Fetten mit 28-011 202-43; Bestellnummer siehe Seite 17 - 1.
Grease with 28-011 202-43; for part number see page 17 - 1.
Graisser avec de la graisse 28-011 202-43; n° de commande, voir page 17 - 1.
Engrase con grasa 28-011 202-43; para el número de pedido véase la página 17 - 1.
- 40/6 Füllen mit 28-011 202-17; Bestellnummer siehe Seite 17 - 1.
Soak with 28-011 202-17; for part number see page 17 - 1.
Imbiber d'huile 28-011 202-17; n° de commande, voir page 17 - 1.
Empage con aceite 28-011 202-17; para el número de pedido véase la página 17 - 1.
- 40/7 Tränken mit 28-011 202-17; Bestellnummer siehe Seite 17 - 1.
Soak with 28-011 202-17; for part number see page 17 - 1.
Imbiber d'huile 28-011 202-17; n° de commande, voir page 17 - 1.
Empage con aceite 28-011 202-17; para el número de pedido véase la página 17 - 1.
- 40/13 Fetten mit 28-011 202-05; Bestellnummer siehe Seite 17 - 1.
Grease with 28-011 202-05; for part number see page 17 - 1.
Graisser avec de la graisse 28-011 202-05; n° de commande, voir page 17 - 1.
Engrase con grasa 28-011 202-05; para el número de pedido véase la página 17 - 1.
- 60 Wahlweise
Optional
Au choix
Opcional
- 81/3 Verwendung je nach Bedarf.
To be used as required.
Utilisation en fonction des besoins.
Utilización según sea necesario
- 95/8 X-Werte bei Bestellung angeben.
Please state x-values on order.
Indiquer les valeurs "x" à la commande.
Indíquese en los pedidos los valores "x".
- 96 Länge angeben
State length
Préciser longueur
Indíquese la largura

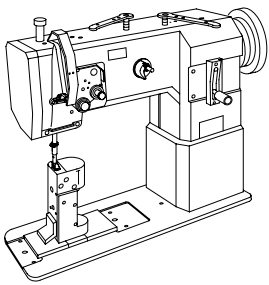

Gehäuseteile
Housing sections
Parties du corps
Piezas del cárter

PFAFF 1295
PFAFF 1296

3.01

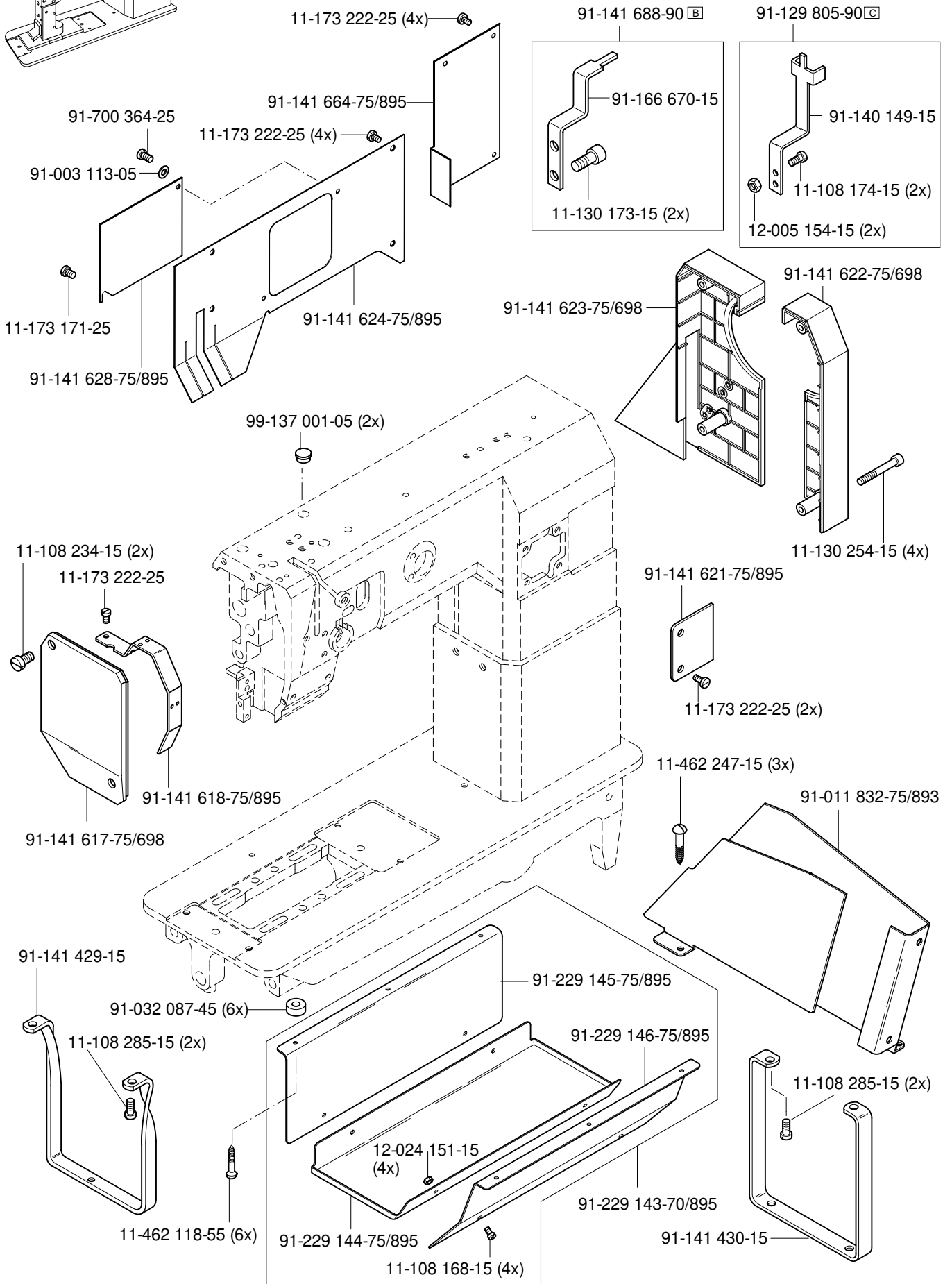

3.02

Kopfteil
Needle head parts
Pièces de tête
Piezas de la cabeza

PFAFF 1295
PFAFF 1296

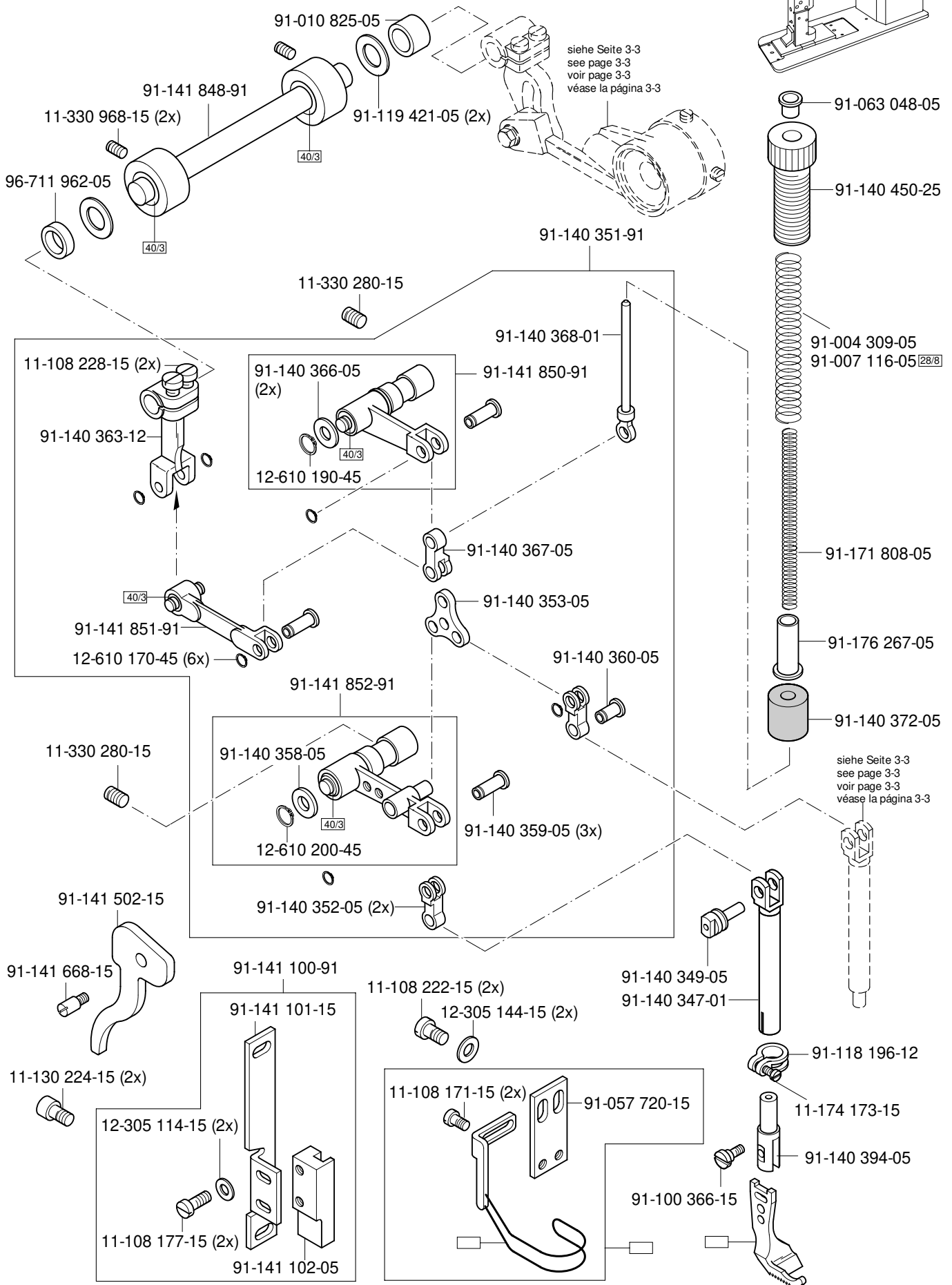
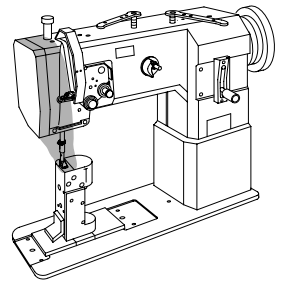

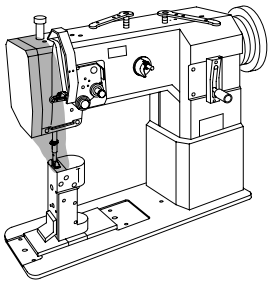

Kopfteile
Needle head parts
Pièces de tête PFAFF 1295
Piezas de la cabeza PFAFF 1296

3.02

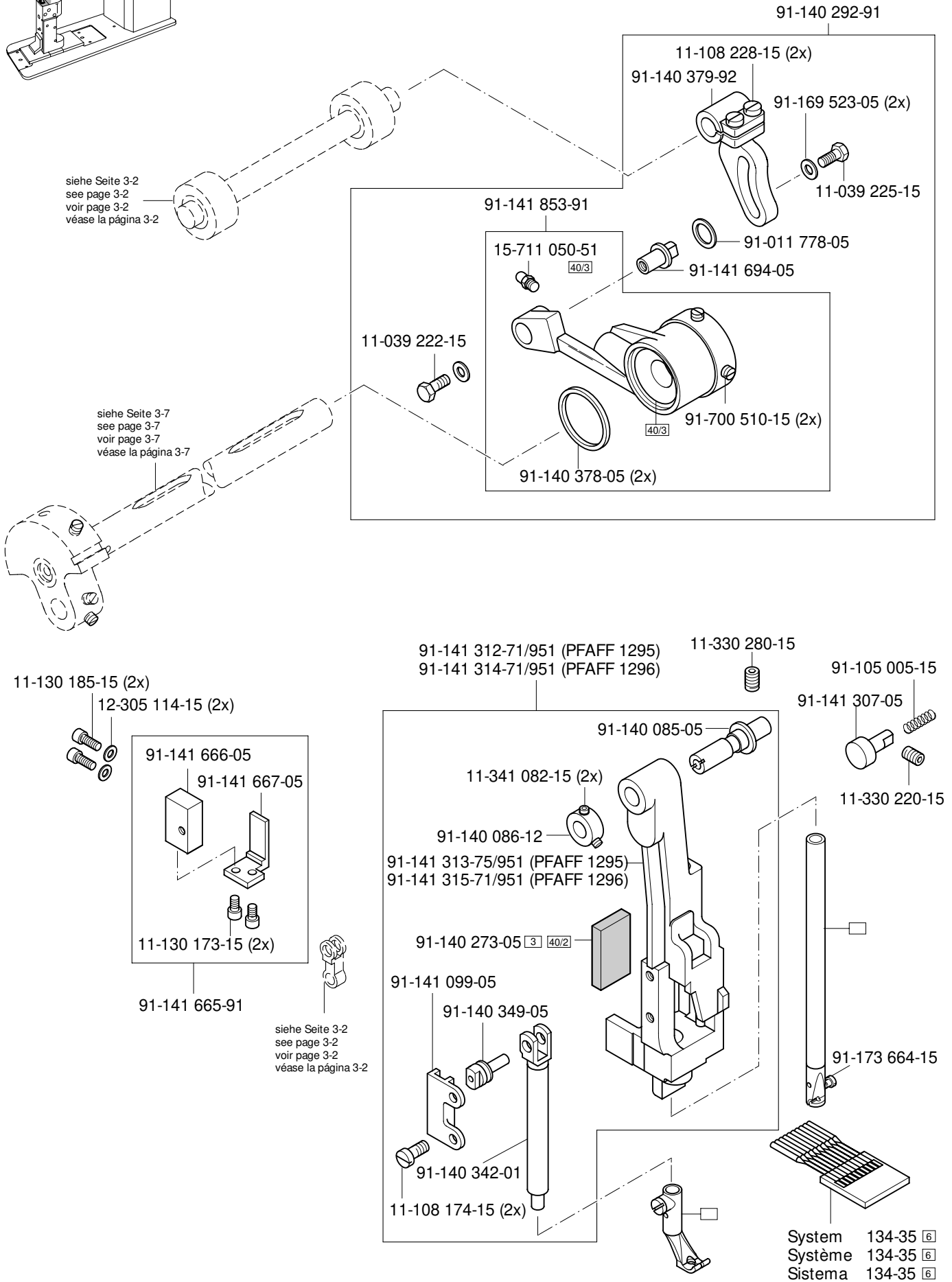

3.02

Kopfteile
Needle head parts
Pièces de tête
Piezas de la cabeza

PFAFF 1295
PFAFF 1296

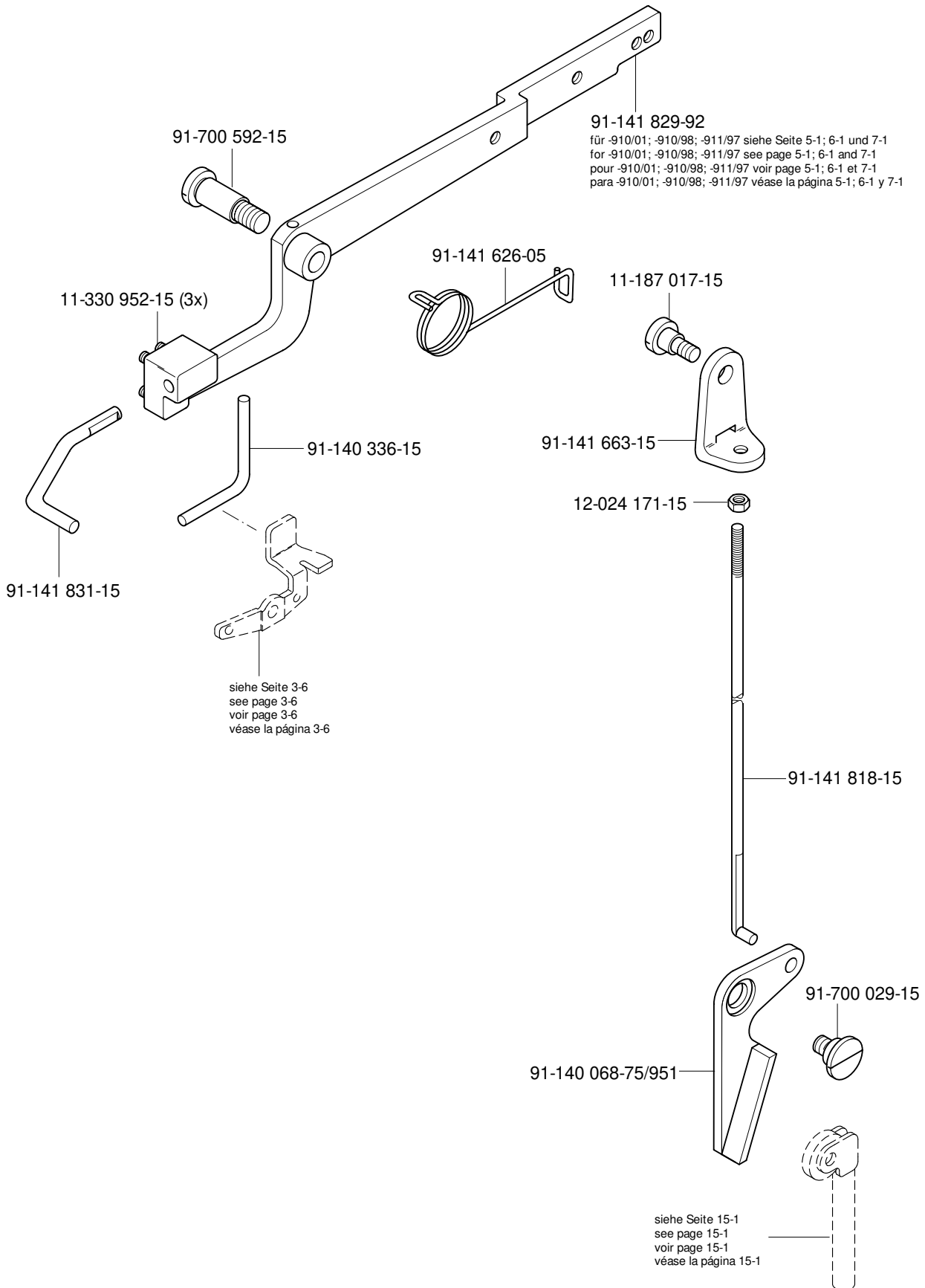
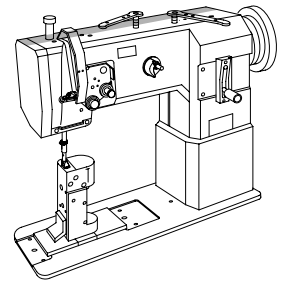

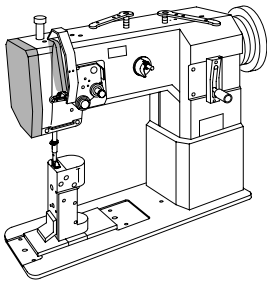

Kopfteile
 Needle head parts
 Pièces de tête PFAFF 1295
 Piezas de la cabeza PFAFF 1296

3.02

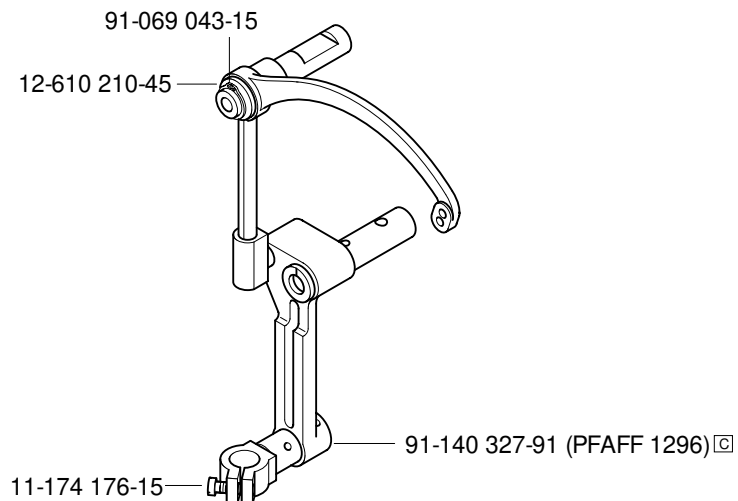
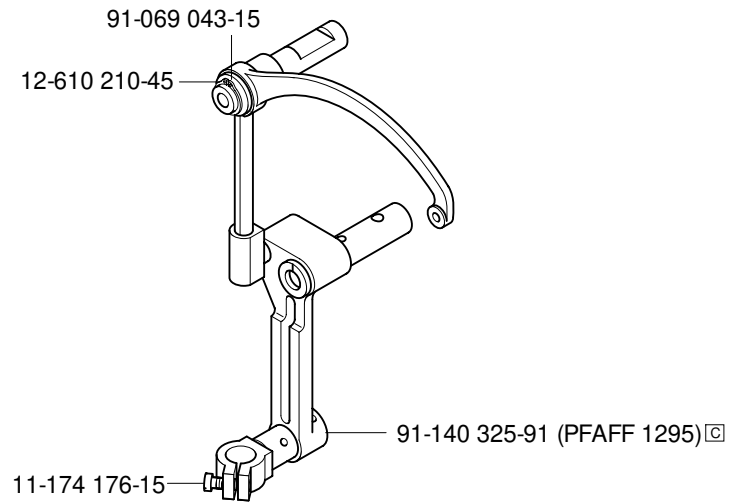
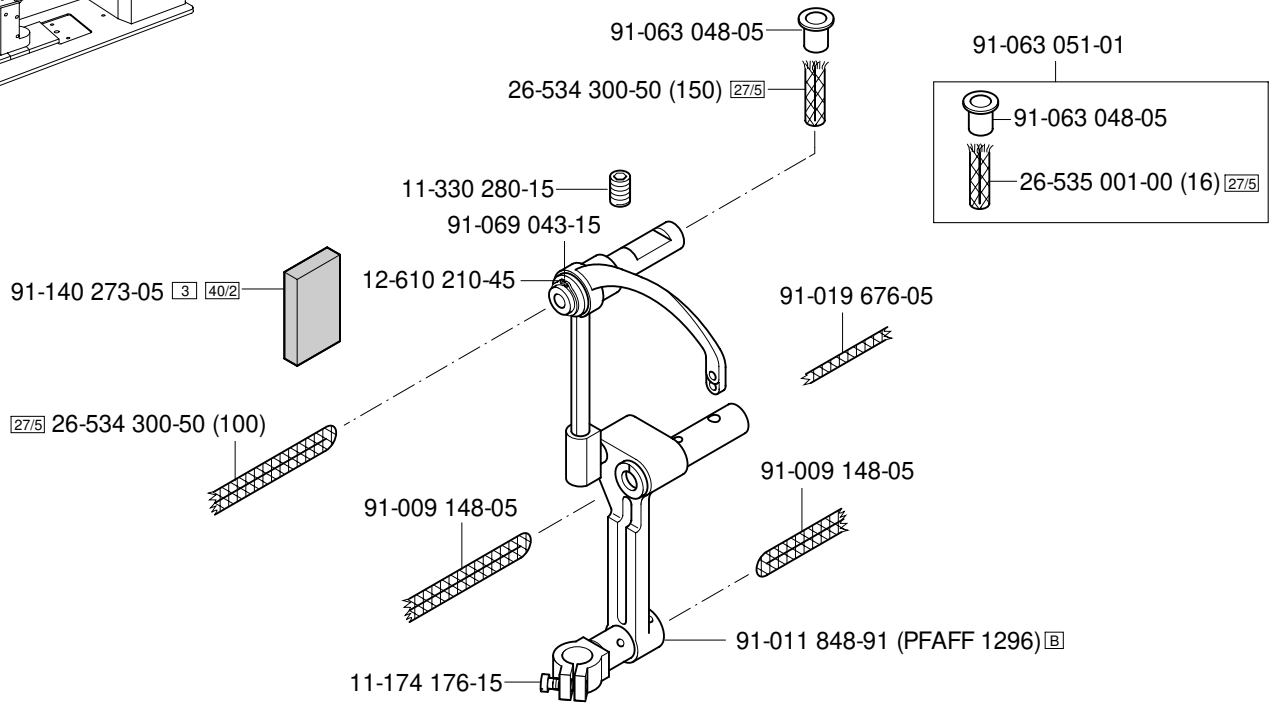

3.02

Kopfteil
Needle head parts
Pièces de tête
Piezas de la cabeza

PFAFF 1295
PFAFF 1296

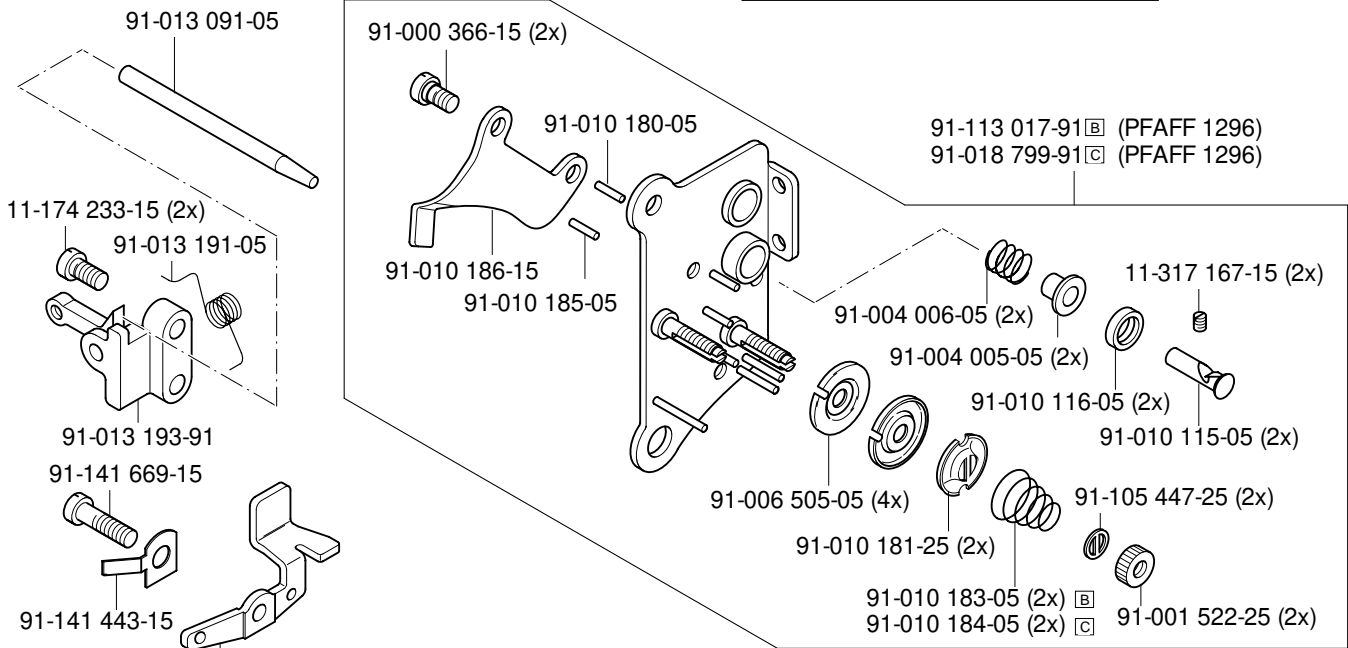
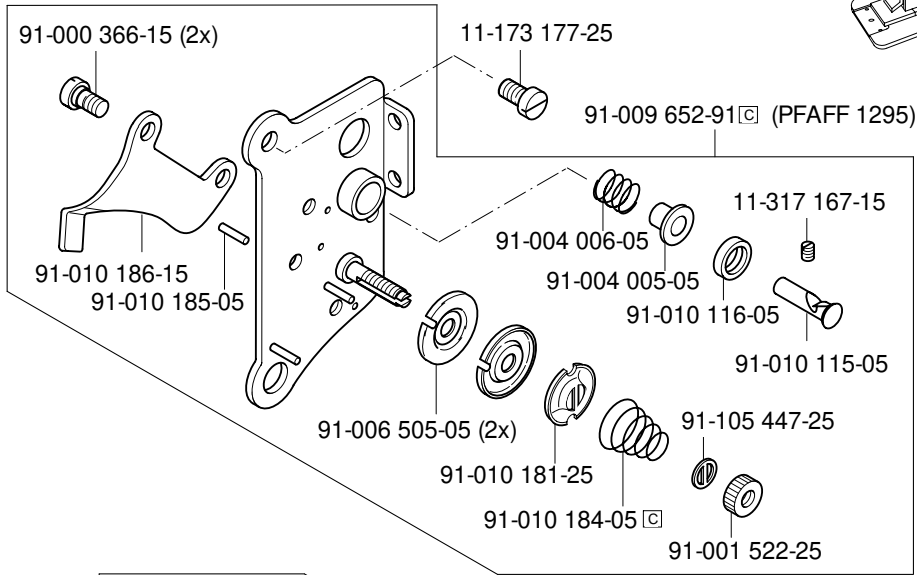
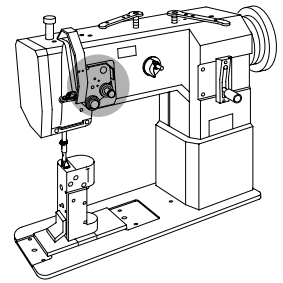

- ▣ 91-010 179-05 (PFAFF 1296)
- ▣ 91-010 937-05 (PFAFF 1295)
- ▣ 91-015 519-05 (PFAFF 1296)

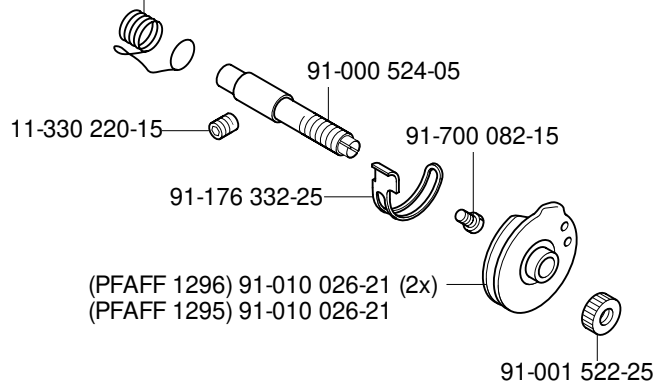
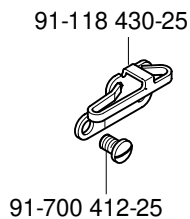
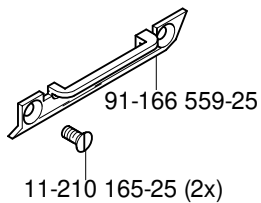

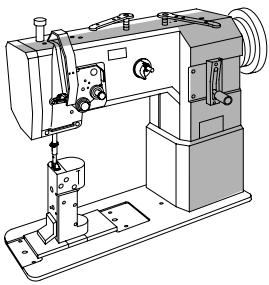

Armteile
 Arm parts
 Pièces de bras PFAFF 1295
 Piezas del brazo PFAFF 1296

3.03

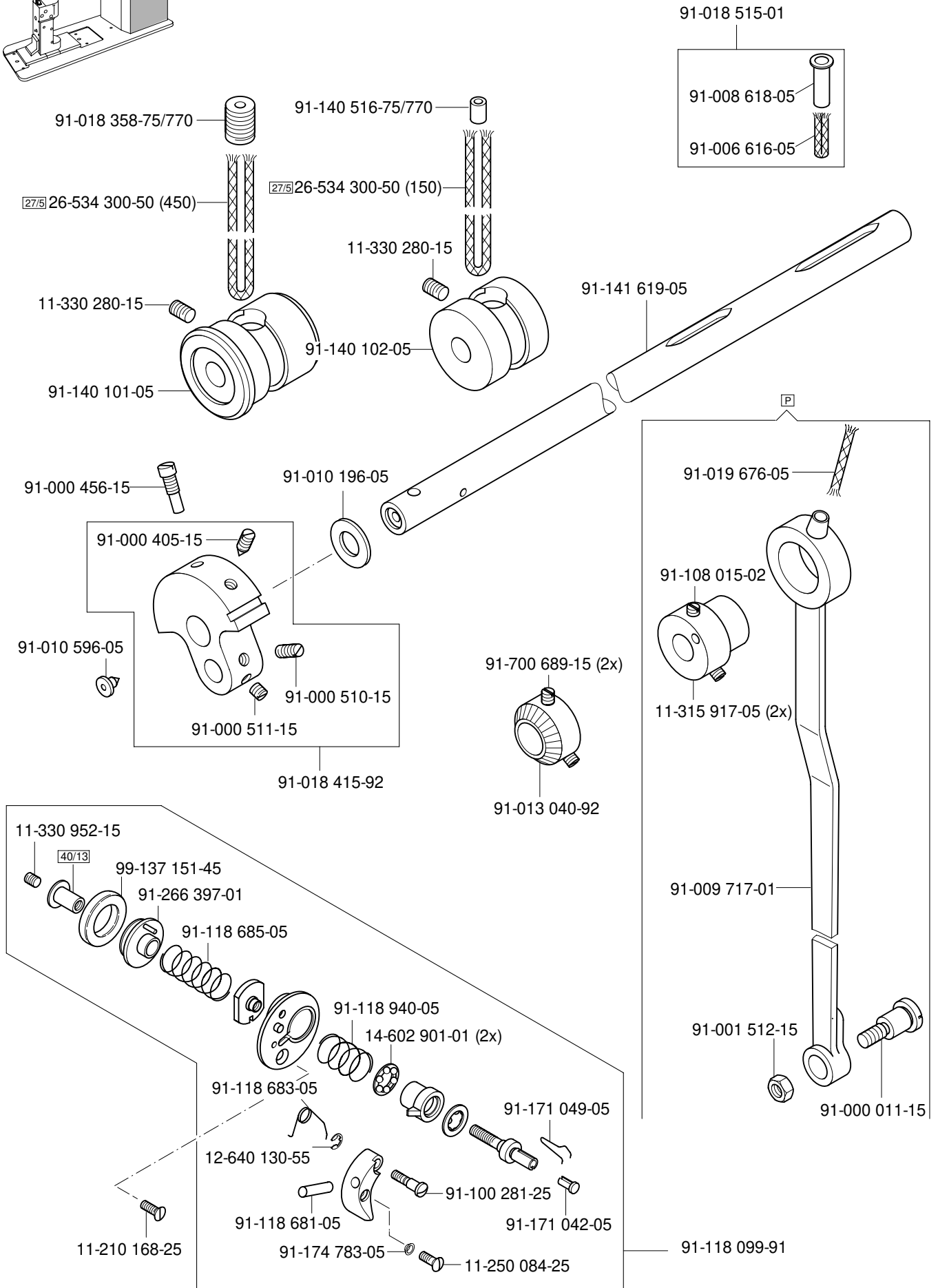

3.03

Armteile
 Arm parts
 Pièces de bras PFAFF 1295
 Piezas del brazo PFAFF 1296

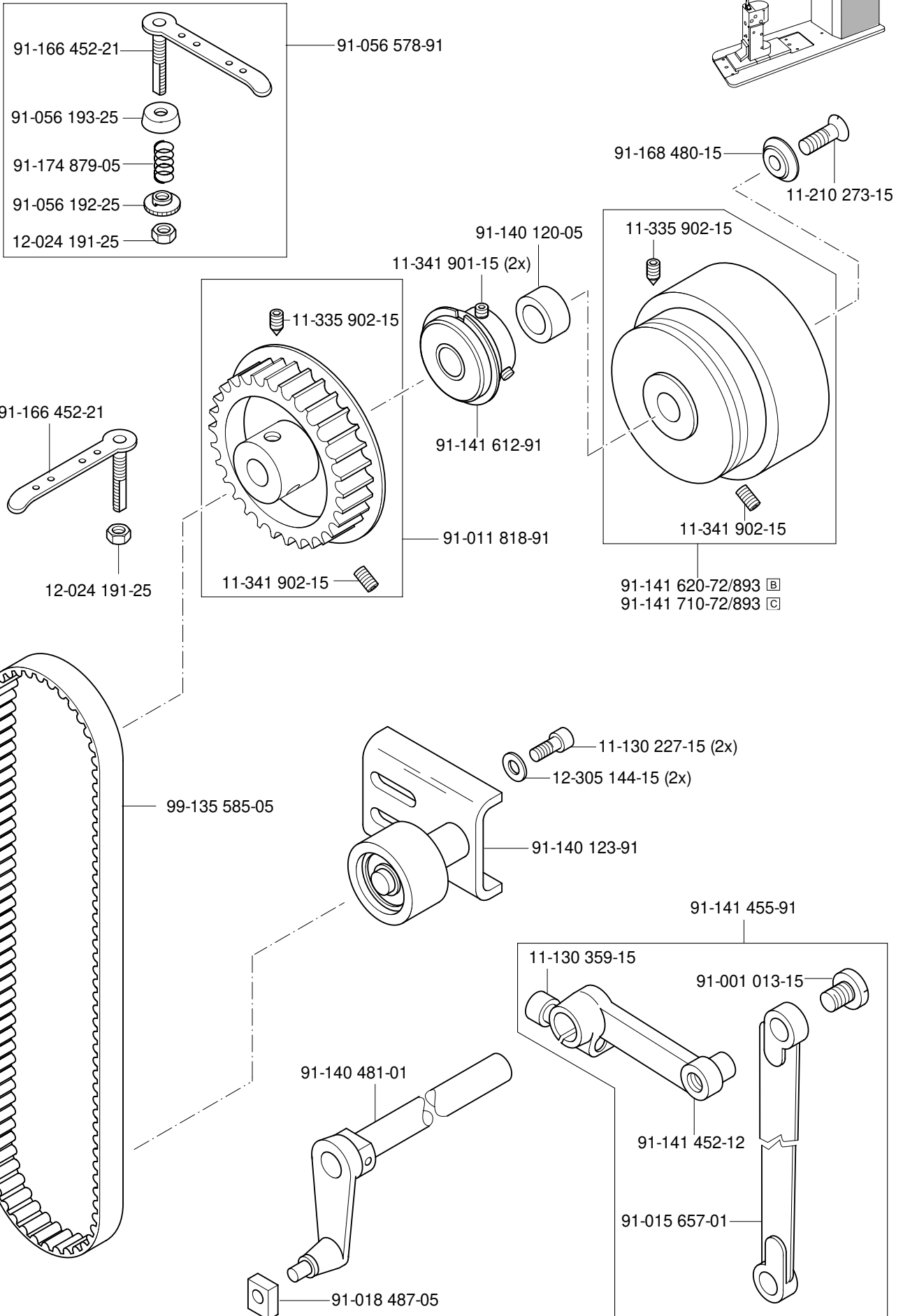
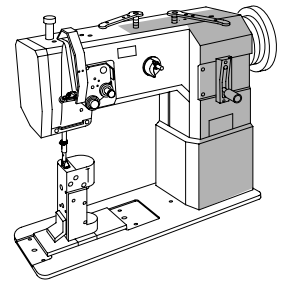

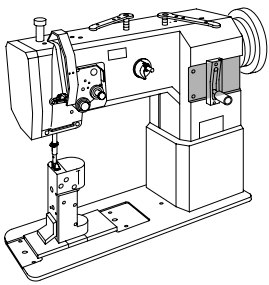

Armteile
 Arm parts
 Pièces de bras PFAFF 1295
 Piezas del brazo PFAFF 1296

3.03

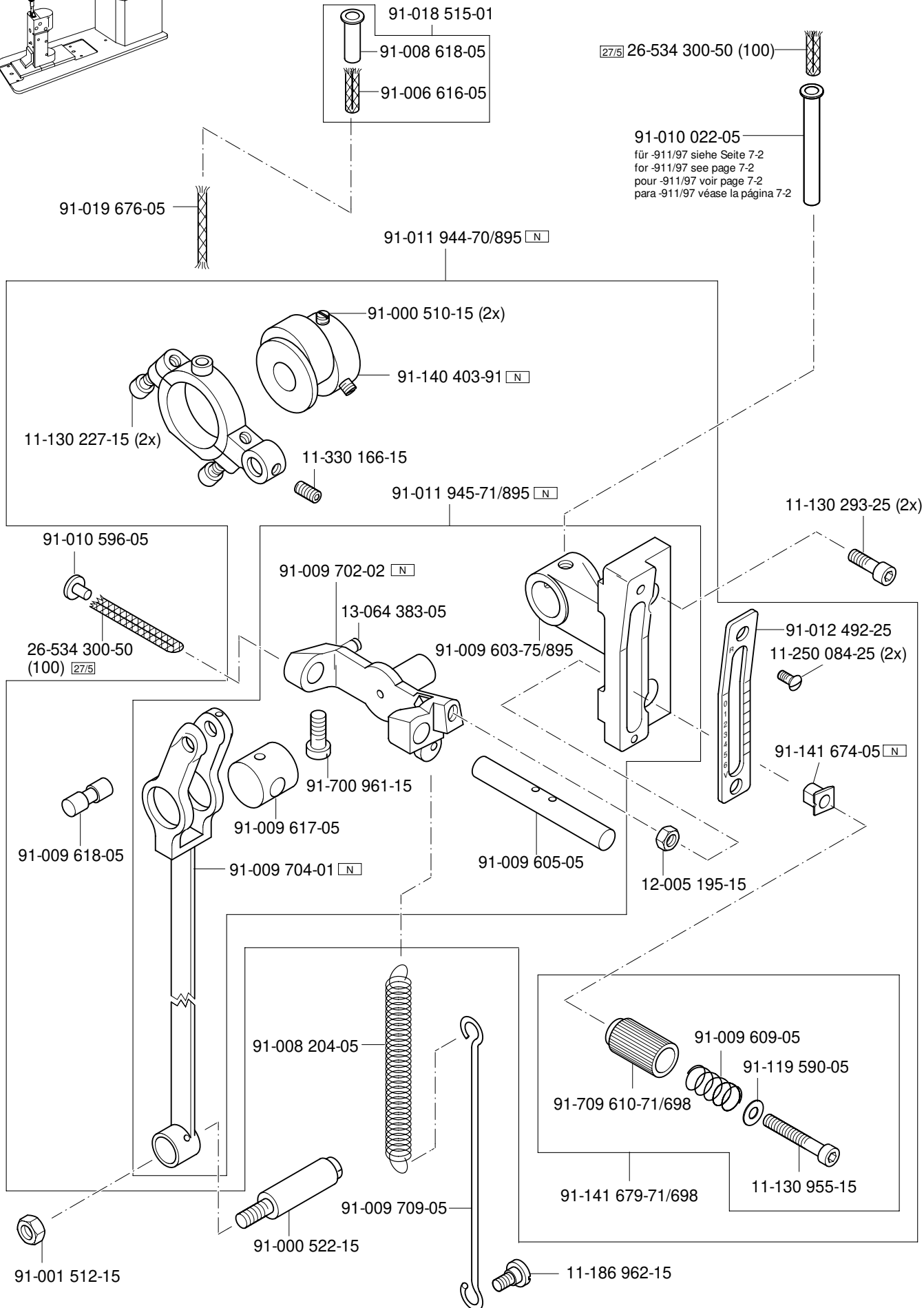

3.04

Grundplattenteile
 Bedplate parts
 Pièces du plateau fondamental
 Piezas del cárter

PFAFF 1295
 PFAFF 1296

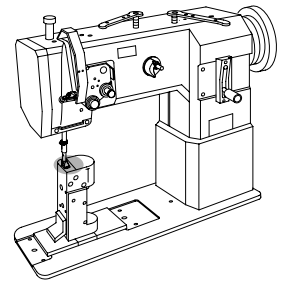

91-018 284-91 } -900/56
 91-018 285-91
 91-018 340-91
 91-018 482-91

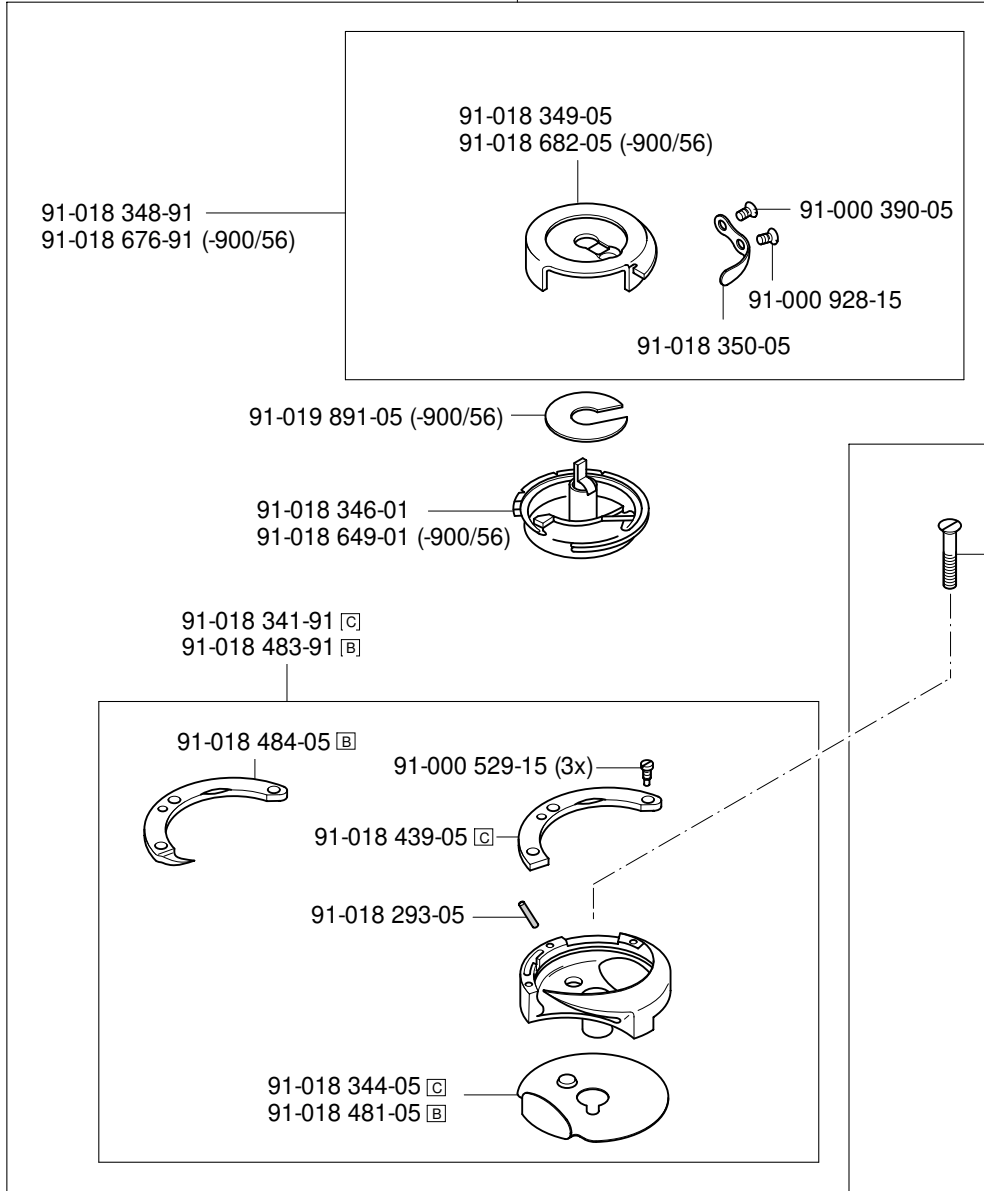

91-018 348-91
 91-018 676-91 (-900/56)

91-018 349-05
 91-018 682-05 (-900/56)

91-000 390-05

91-000 928-15

91-018 350-05

91-019 891-05 (-900/56)

91-018 346-01
 91-018 649-01 (-900/56)

91-000 525-15

91-018 341-91
 91-018 483-91

91-018 484-05

91-000 529-15 (3x)

91-018 439-05

91-018 293-05

91-018 344-05
 91-018 481-05

91-018 339-05
 91-018 480-05 (-900/56)

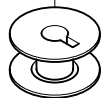

siehe Seite 3-11; 3-12; 3-13; 4-2; 4-3 und 4-4
 see page 3-11; 3-12; 3-13; 4-2; 4-3 and 4-4
 voir page 3-11; 3-12; 3-13; 4-2; 4-3 et 4-4
 véase la página 3-11; 3-12; 3-13; 4-2; 4-3 y 4-4

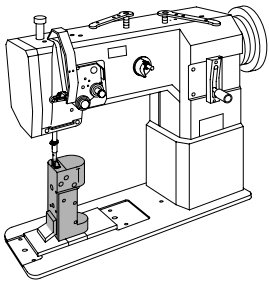

Grundplattenteile
 Bedplate parts
 Pièces du plateau fondamental
 Piezas del cárter

PFAFF 1295

3.04

für -900/56; -940/01 siehe Seite 4-2 und 9-1
 for -900/56; -940/01 see page 4-2 and 9-1
 pour -900/56; -940/01 voir page 4-2 et 9-1
 para -900/56; -940/01 véase la página 4-2 y 9-1
 91-012 698-73/002 ☐

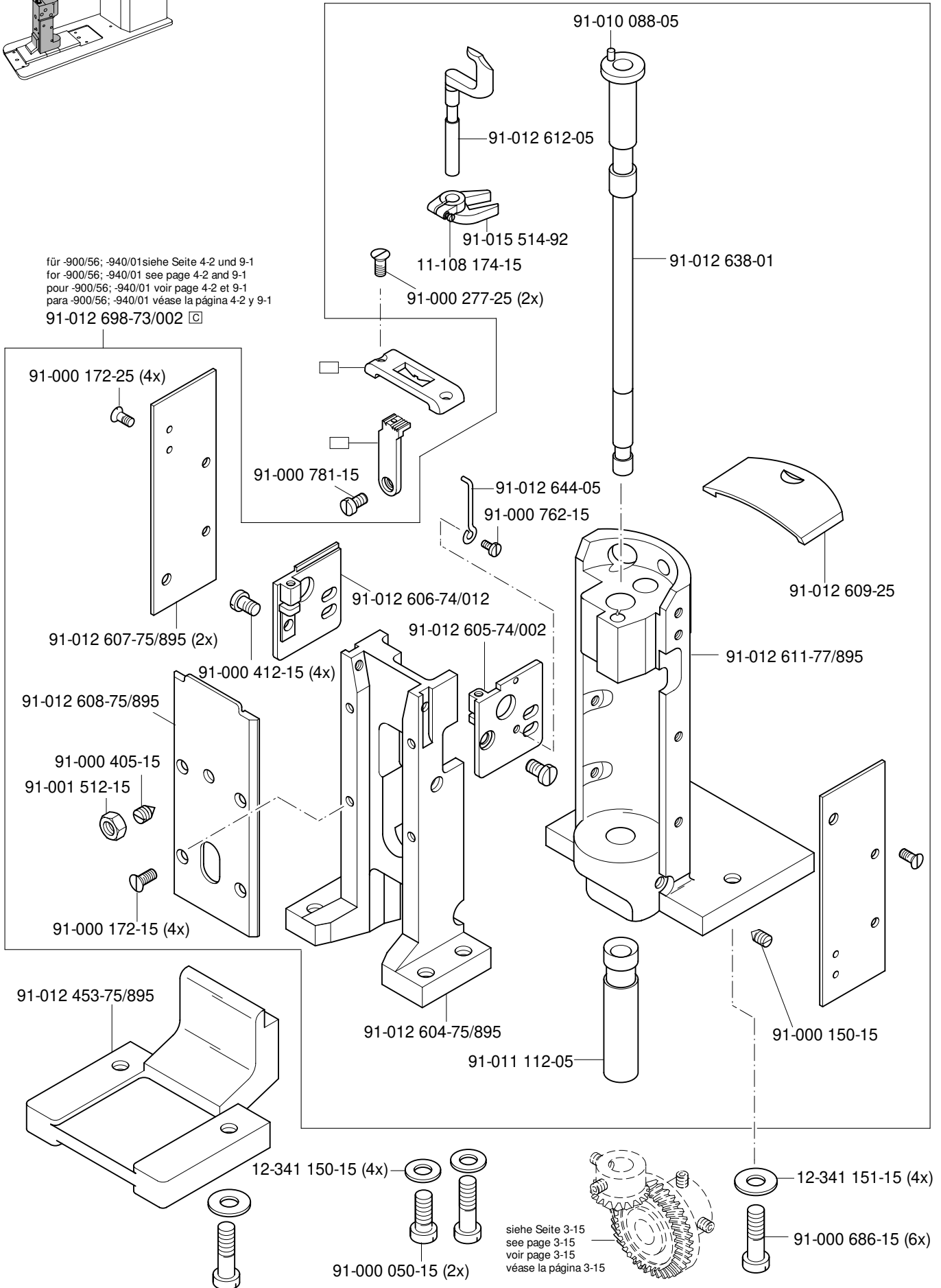

3.04

Grundplattenteile
 Bedplate parts
 Pièces du plateau fondamental
 Piezas del cárter

PFAFF 1296

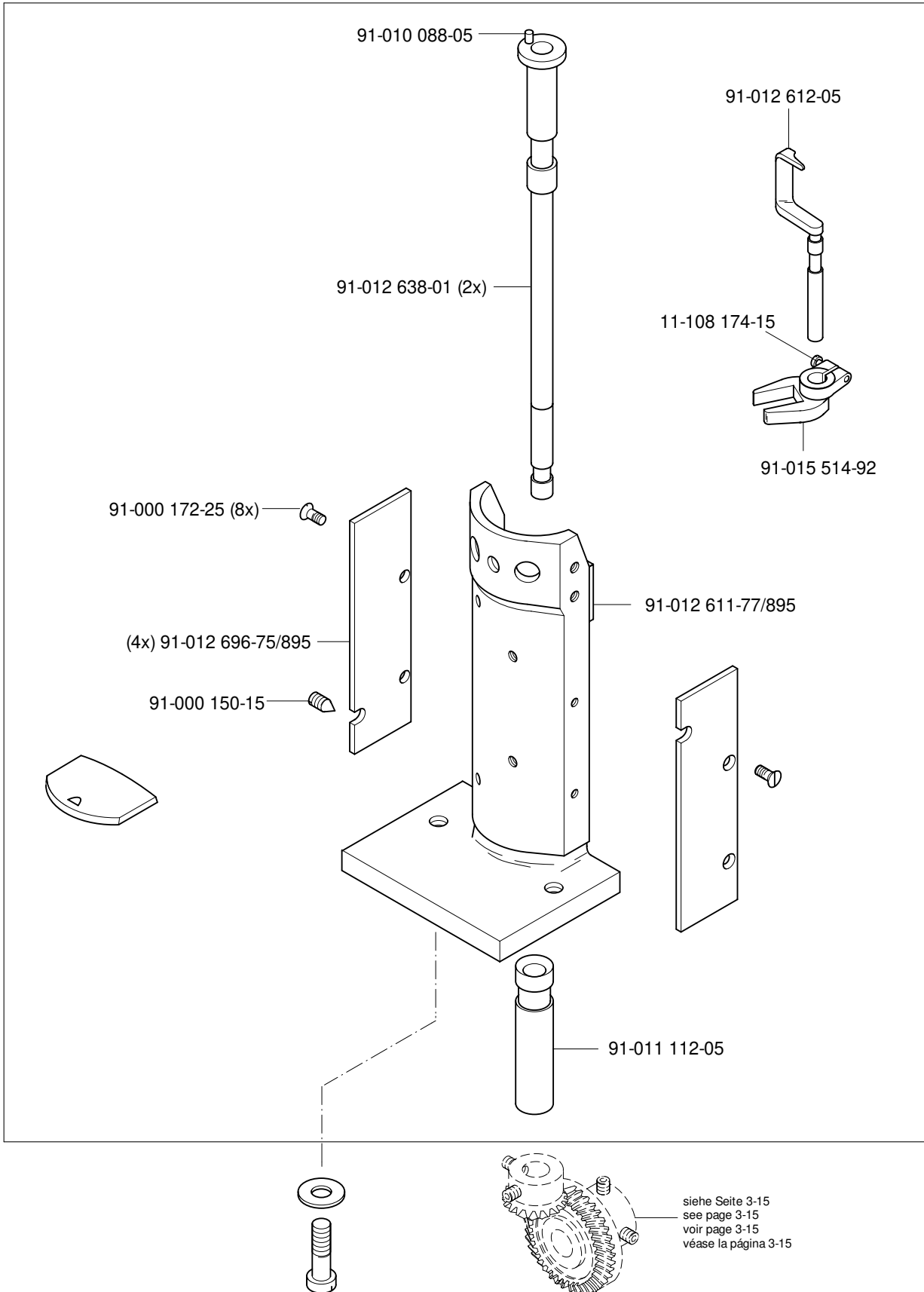
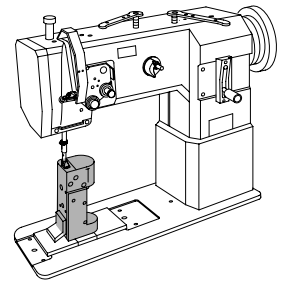

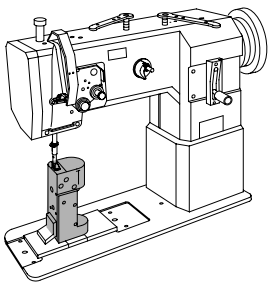

Grundplattenteile
 Bedplate parts
 Pièces du plateau fondamental
 Piezas del cárter

PFAFF 1296

3.04

91-012 653-73/001 für -900/56 siehe Seite 4-3
 for -900/56 see page 4-3
 pour -900/56 voir page 4-3
 para -900/56 véase la página 4-3

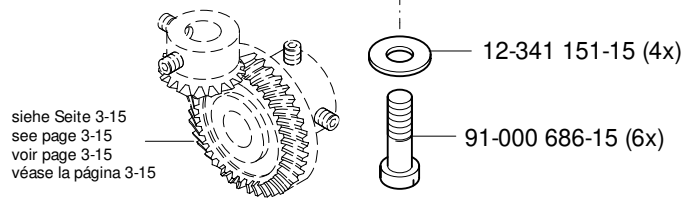
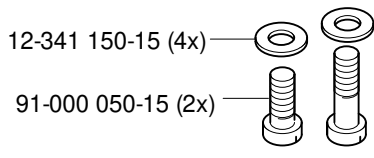
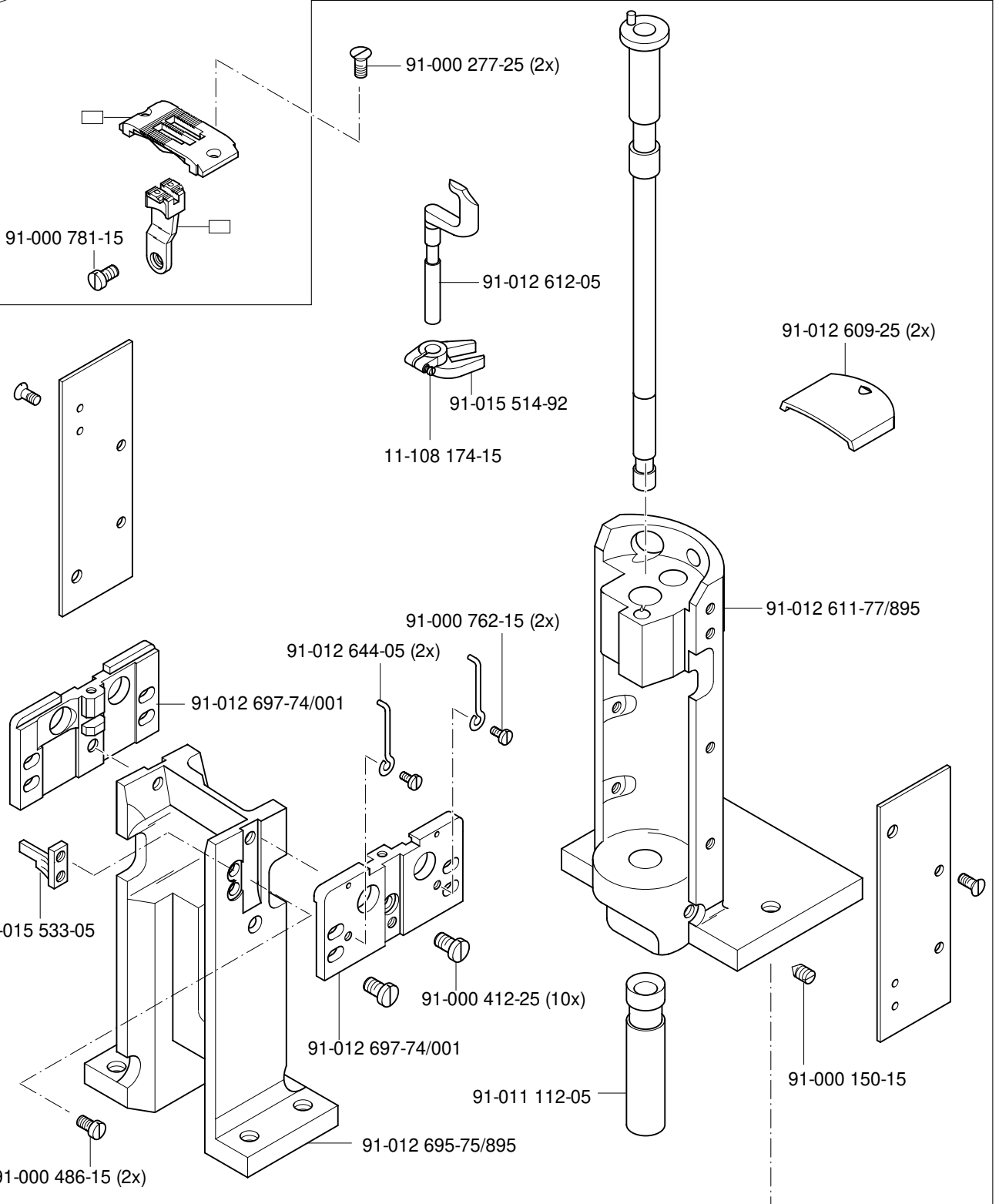

3.04

Grundplattenteile
Bedplate parts
Pièces du plateau fondamental
Piezas del cárter

PFAFF 1295
PFAFF 1296

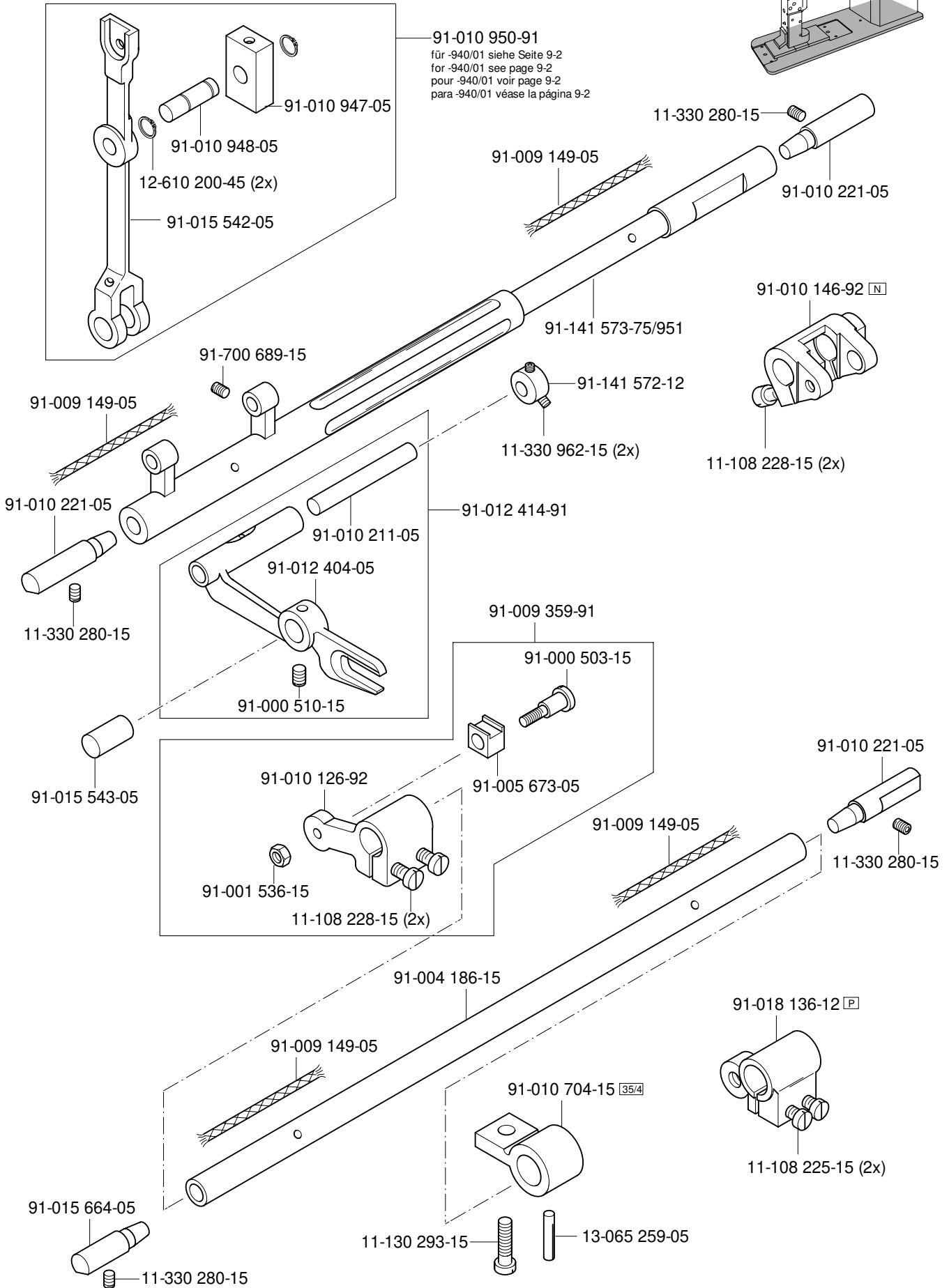
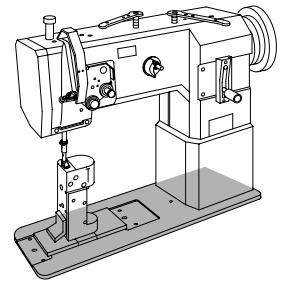

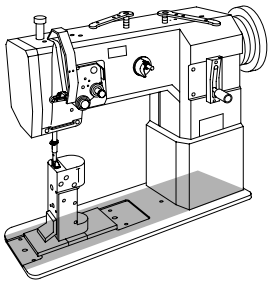

Grundplattenteile

Bedplate parts

Pièces du plateau fondamental

Piezas del cárter

PFAFF 1295

PFAFF 1296

3.04

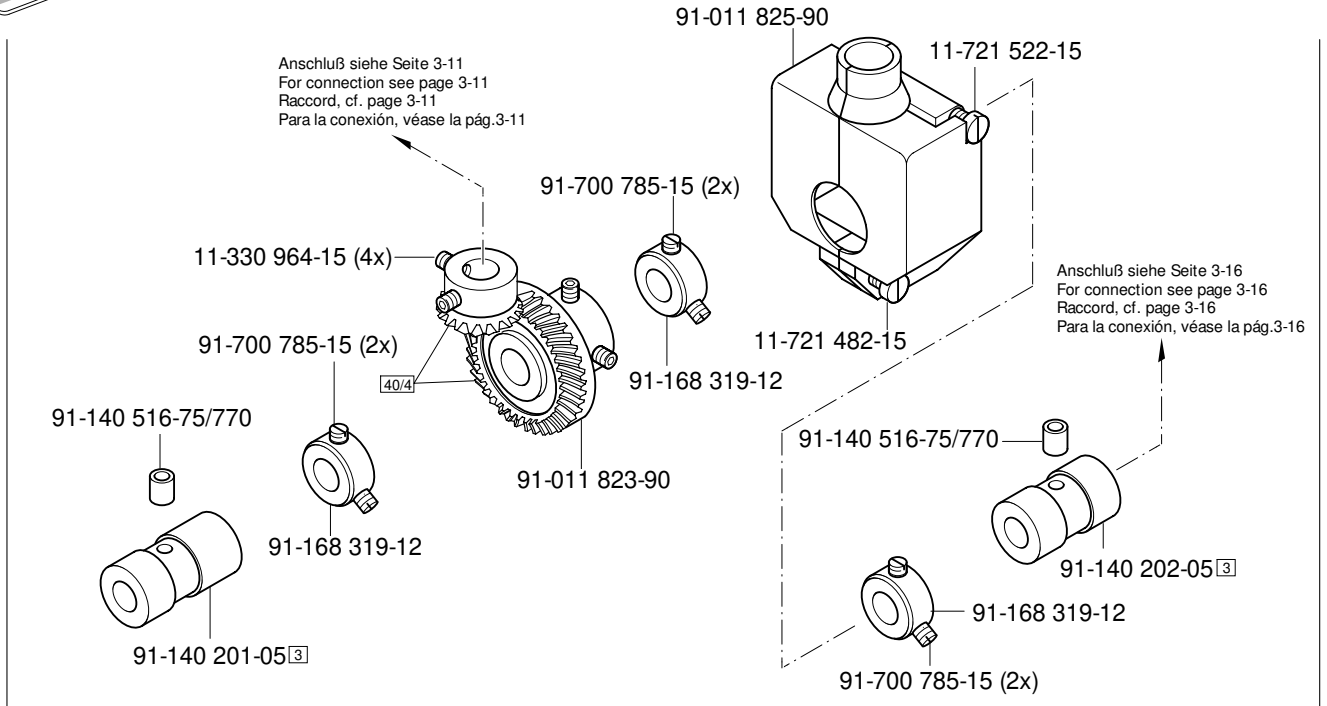

(PFAFF 1295)

(PFAFF 1296)

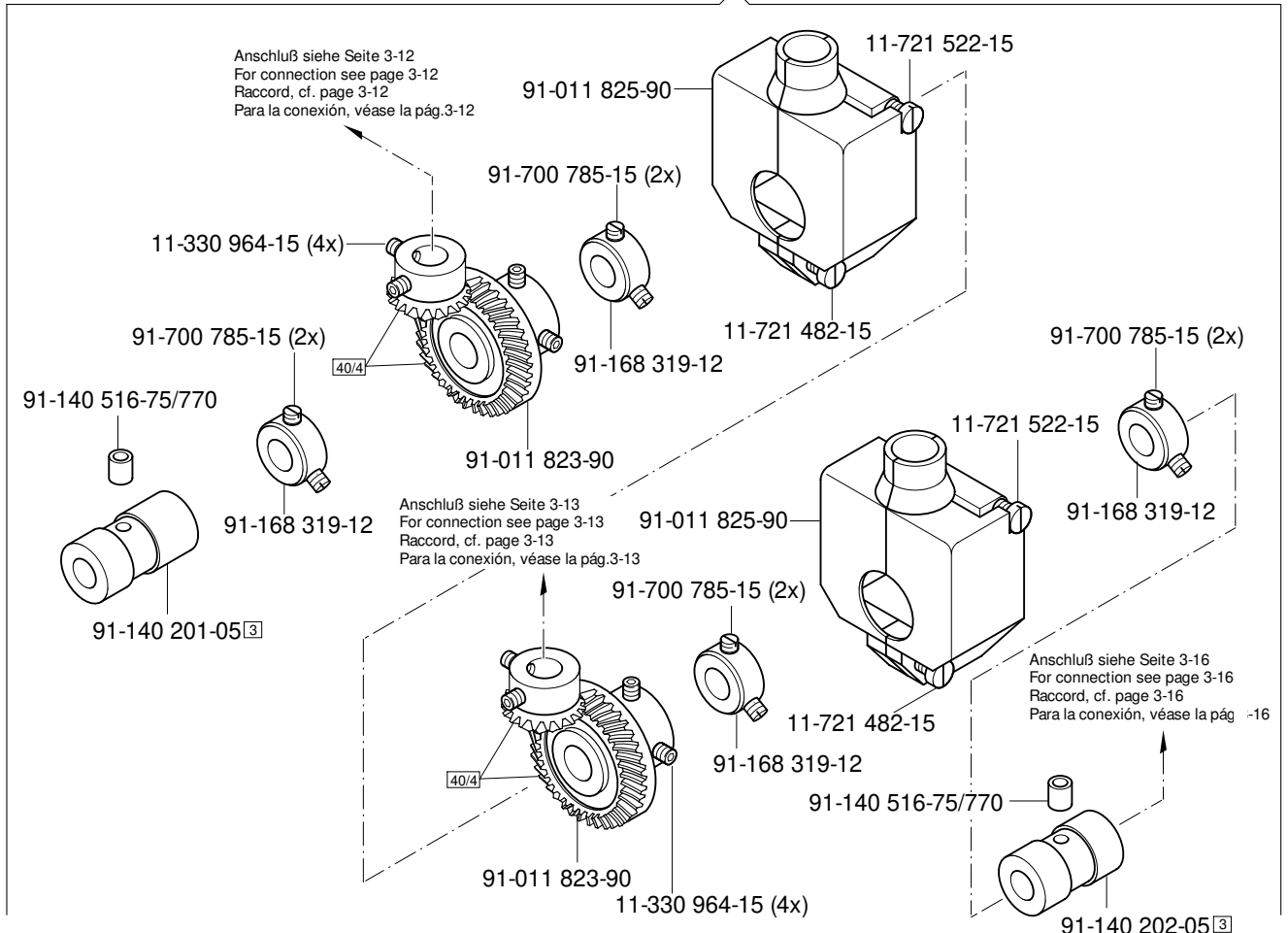

3.04

Grundplattenteile
 Bedplate parts
 Pièces du plateau fondamental
 Piezas del cárter

PFAFF 1295
 PFAFF 1296

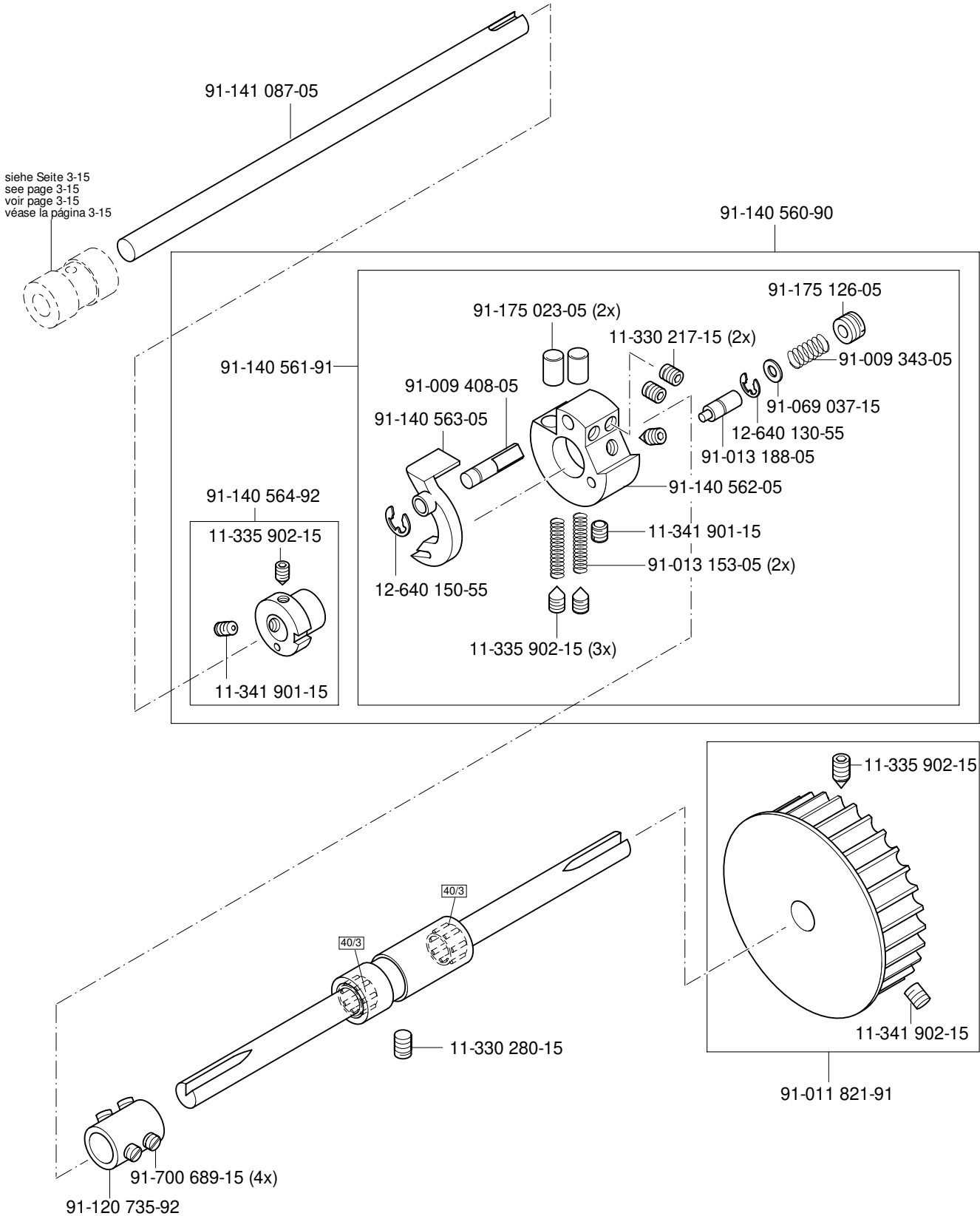
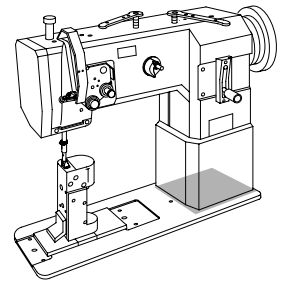

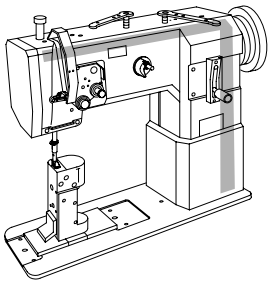

Fadenabschneid-Einrichtung (-900/56)
 Thread trimmer (-900/56)
 Coupe-fil (-900/56)
 Cortahilos (-900/56)

PFAFF 1295
 PFAFF 1296

(PFAFF 1296)

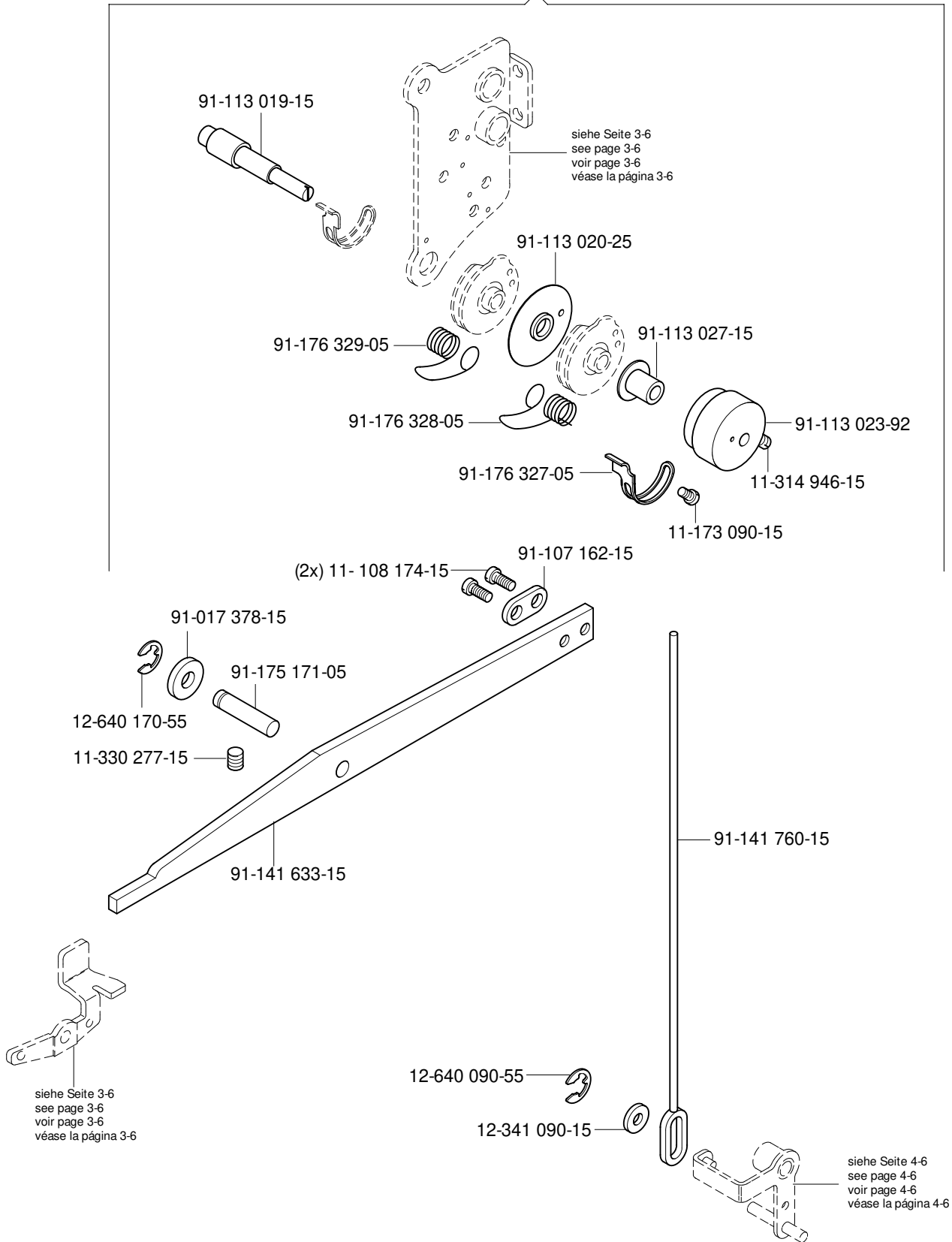

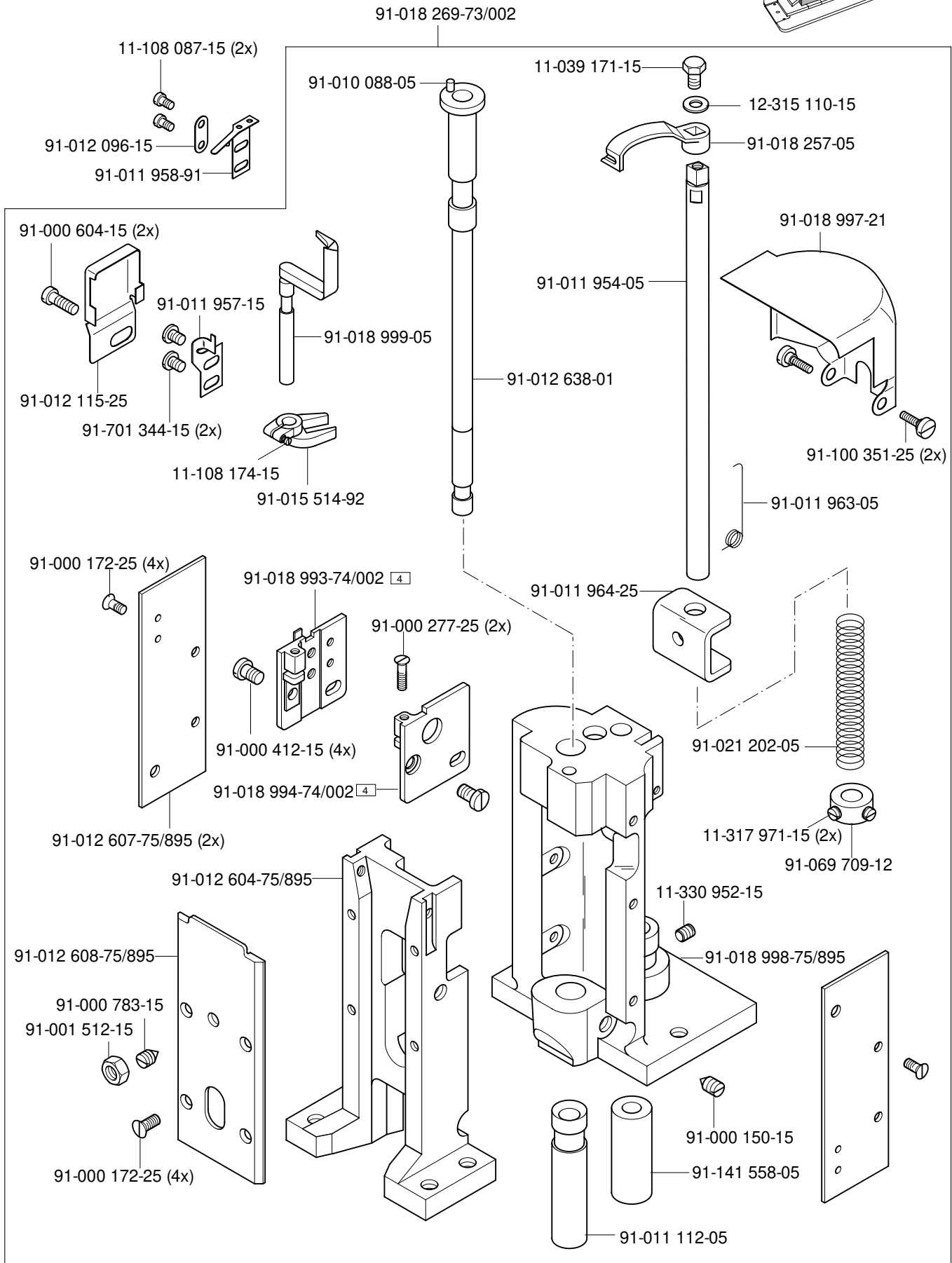
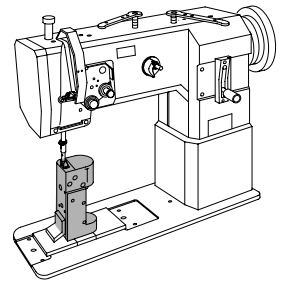

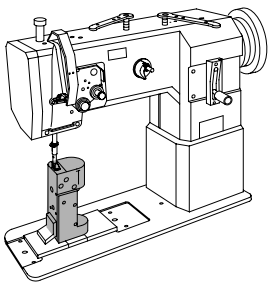

Fadenabschneid-Einrichtung (-900/56)
 Thread trimmer (-900/56)
 Coupe-fil (-900/56)
 Cortahilos (-900/56)

PFAFF 1296

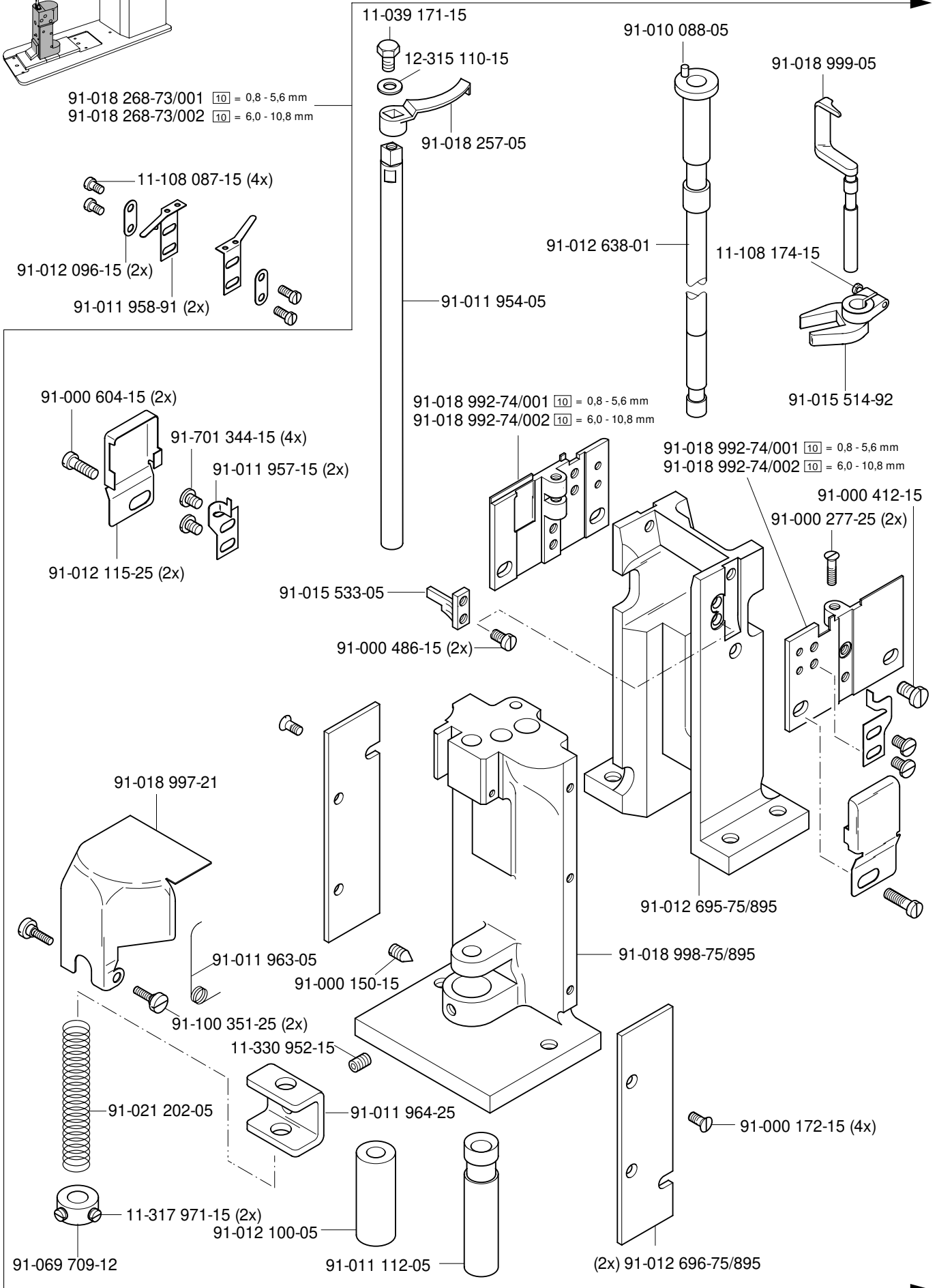

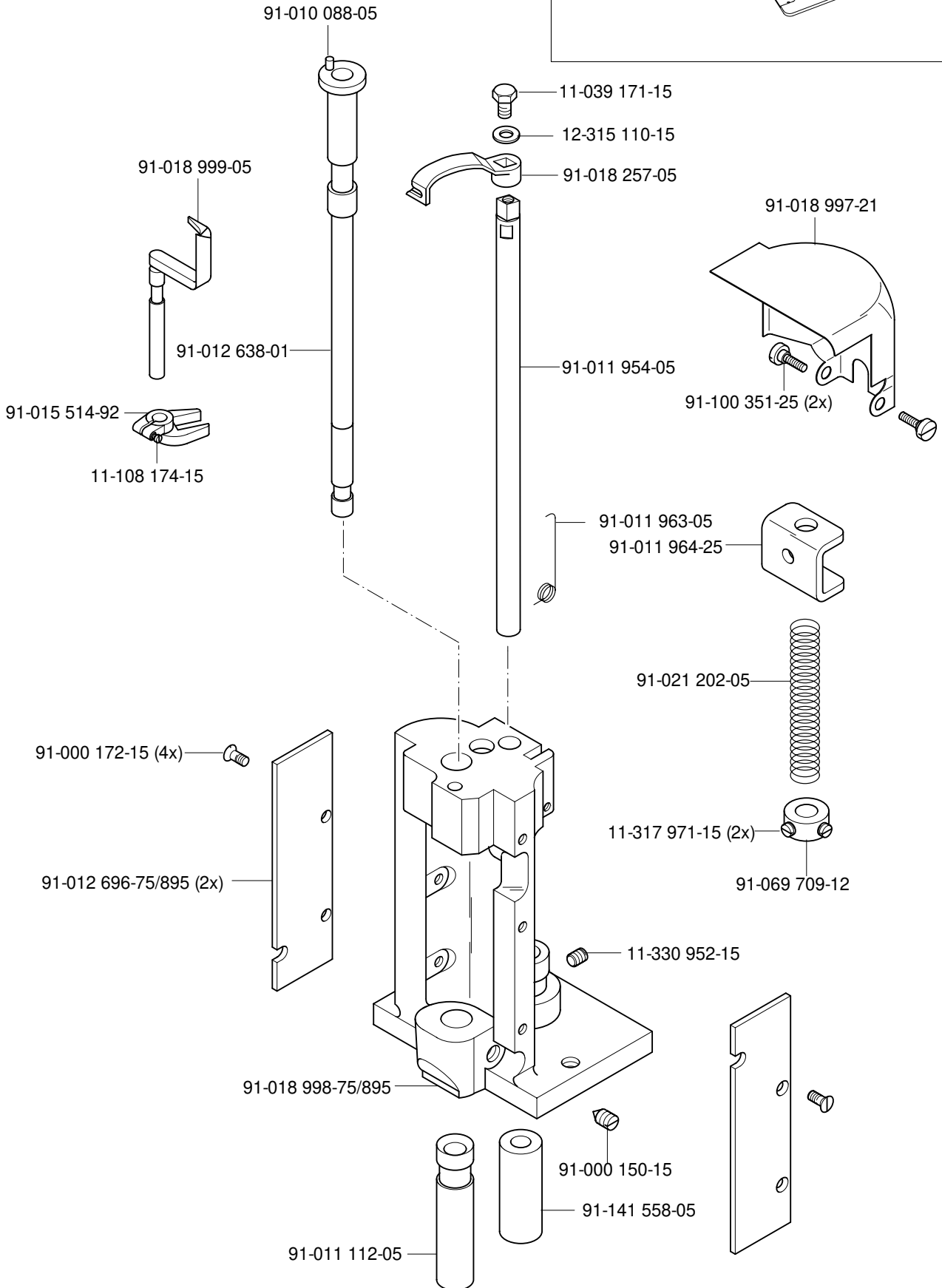
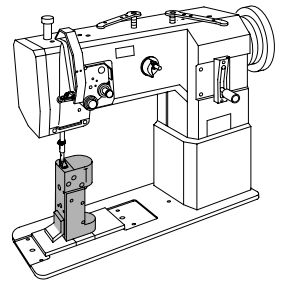

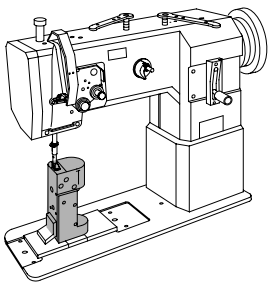

Fadenabschneid-Einrichtung (-900/56)
 Thread trimmer (-900/56)
 Coupe-fil (-900/56)
 Cortahilos (-900/56)

PFAFF 1295
 PFAFF 1296

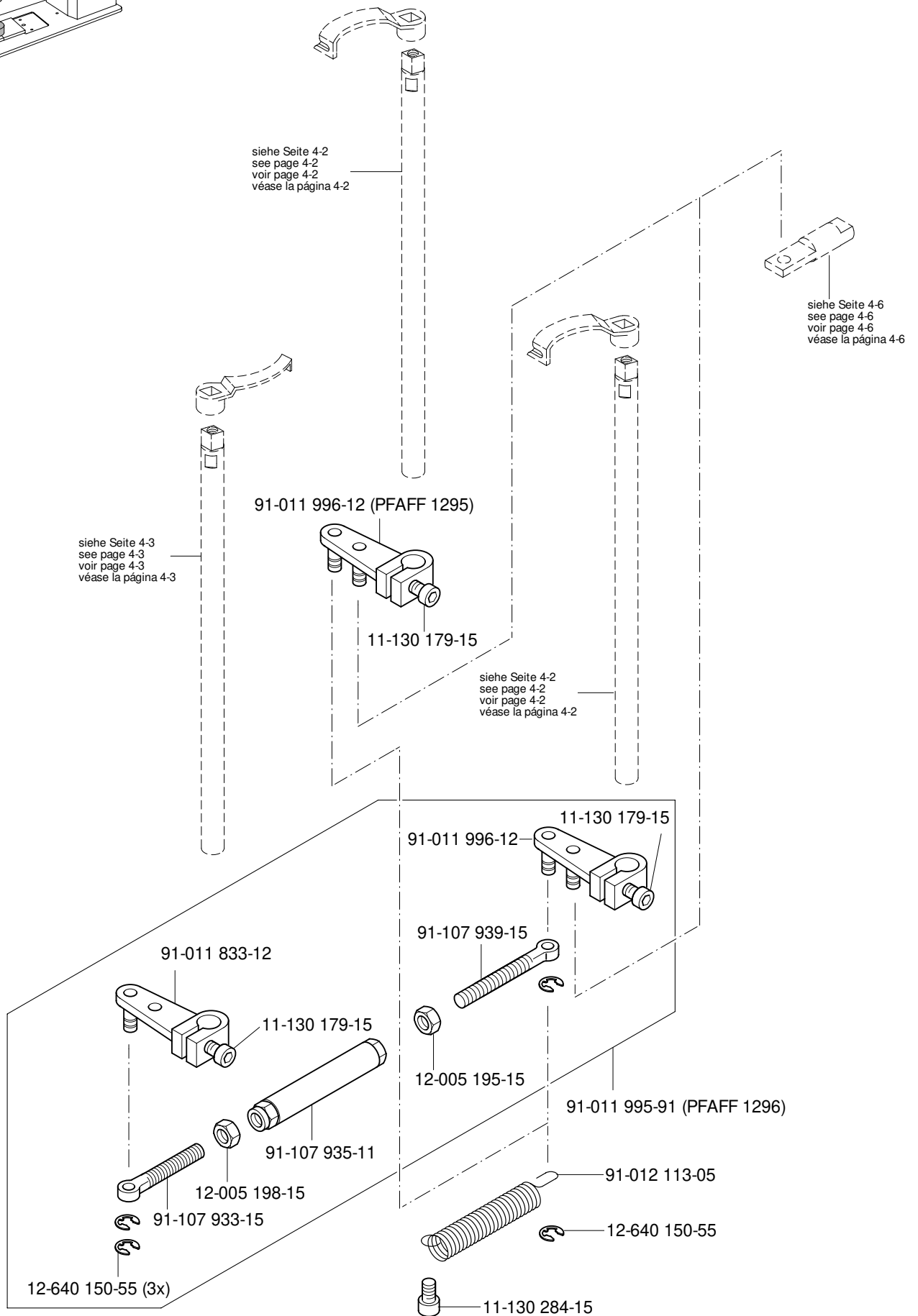

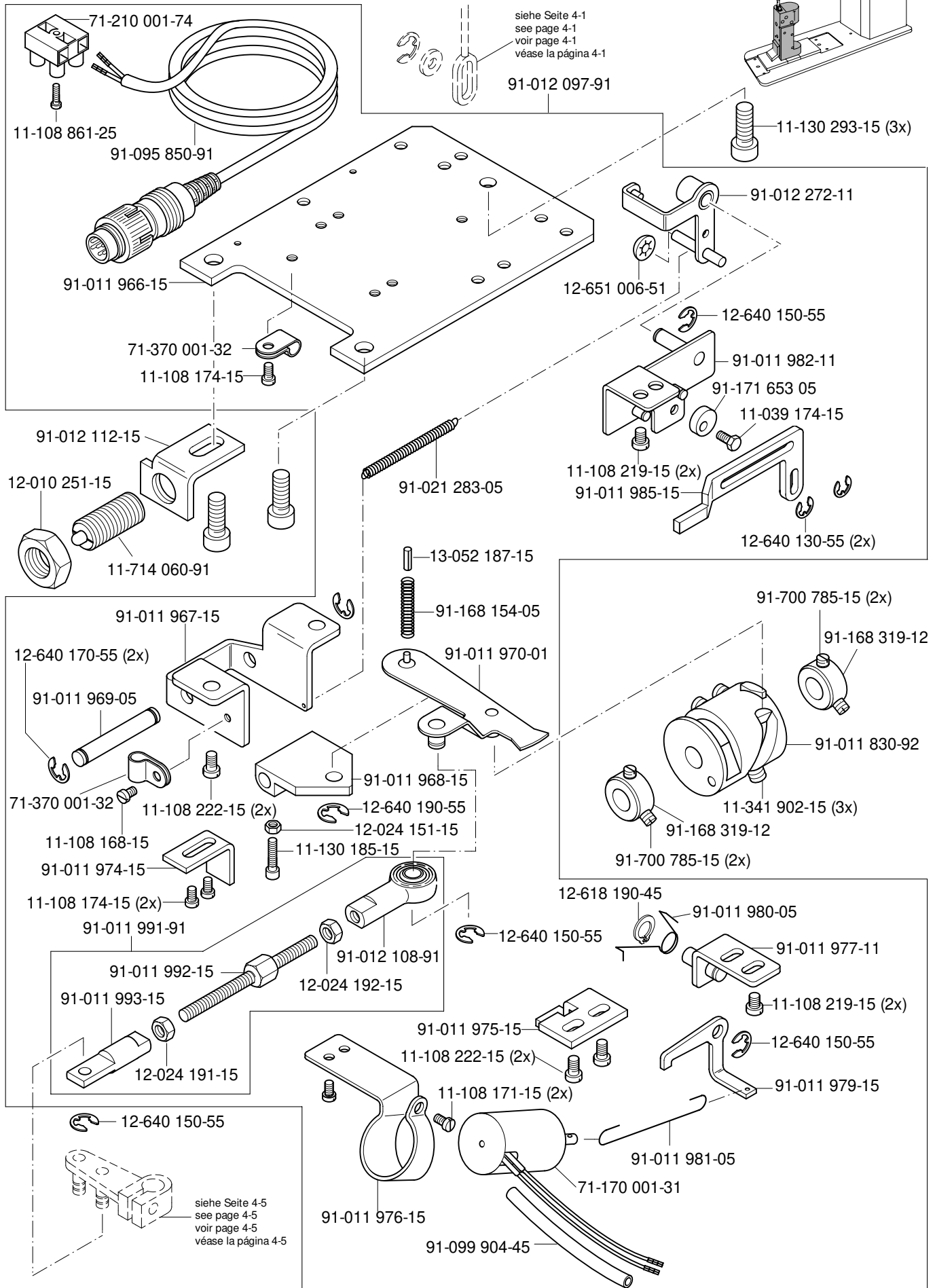
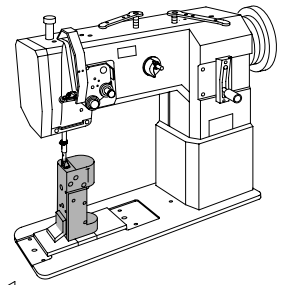

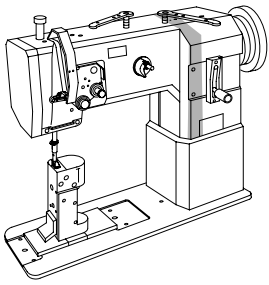

Nähfuß heben über Pedal(-910/01)
 Raiser presser foot via the pedal (-910/01)
 Relever le pied presseur en actionnant la pédale (-910/01)
 Elevación del prensatelas mediante pedal (-910/01)

PFAFF 1295
 PFAFF 1296

5

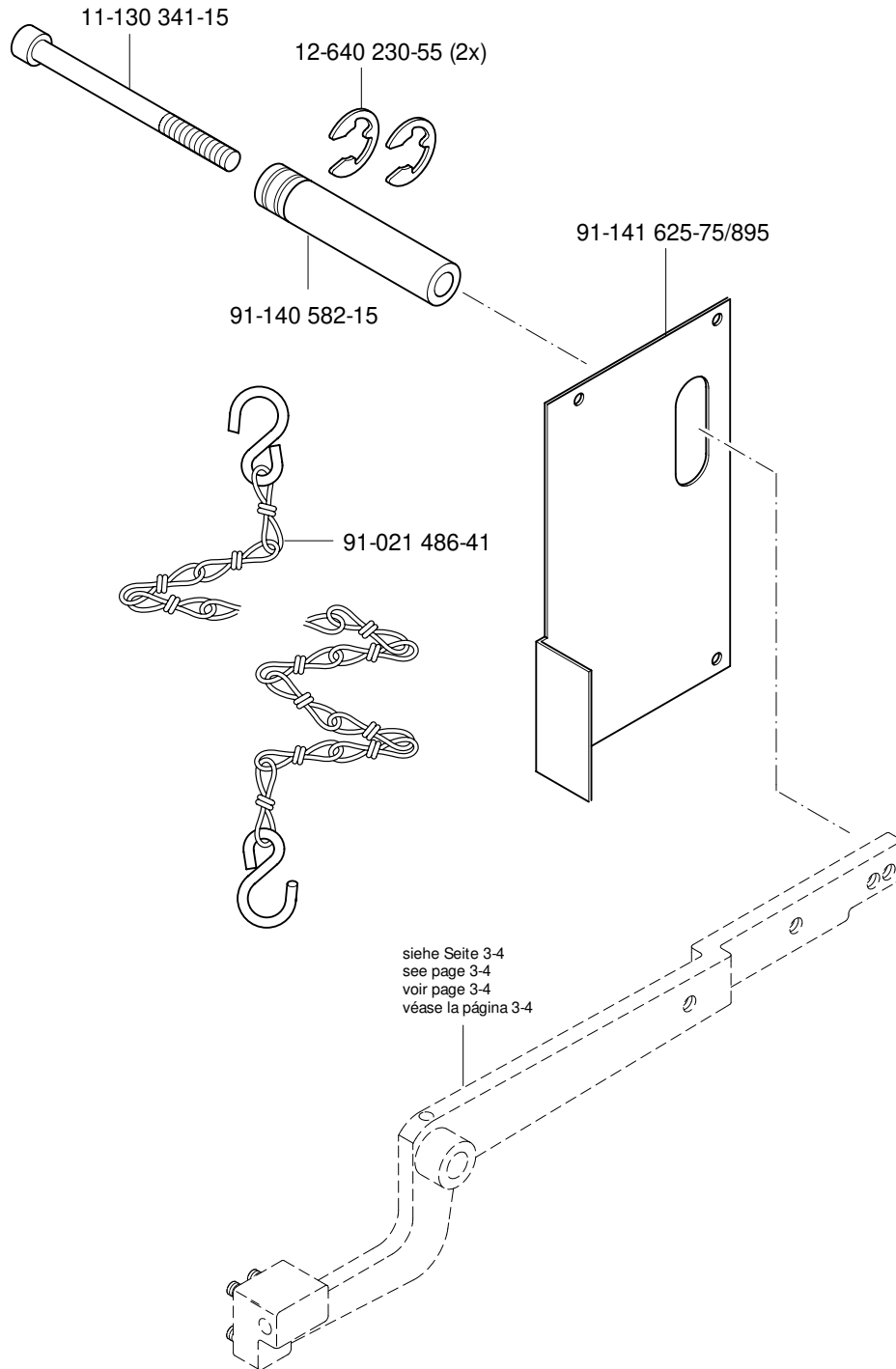

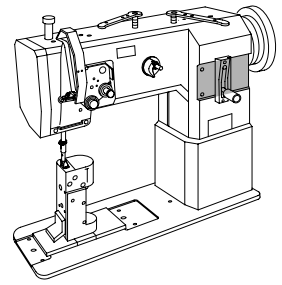

Wartungseinheit -925/03 erforderlich
 Conditioning unit -925/03 required
 Conditionneur d'air comprimé -925/03 nécessaire
 Requiere grupo acondicionador del aire comprimido -925/03

siehe Seite 3-4
 see page 3-4
 voir page 3-4
 véase la página 3-4

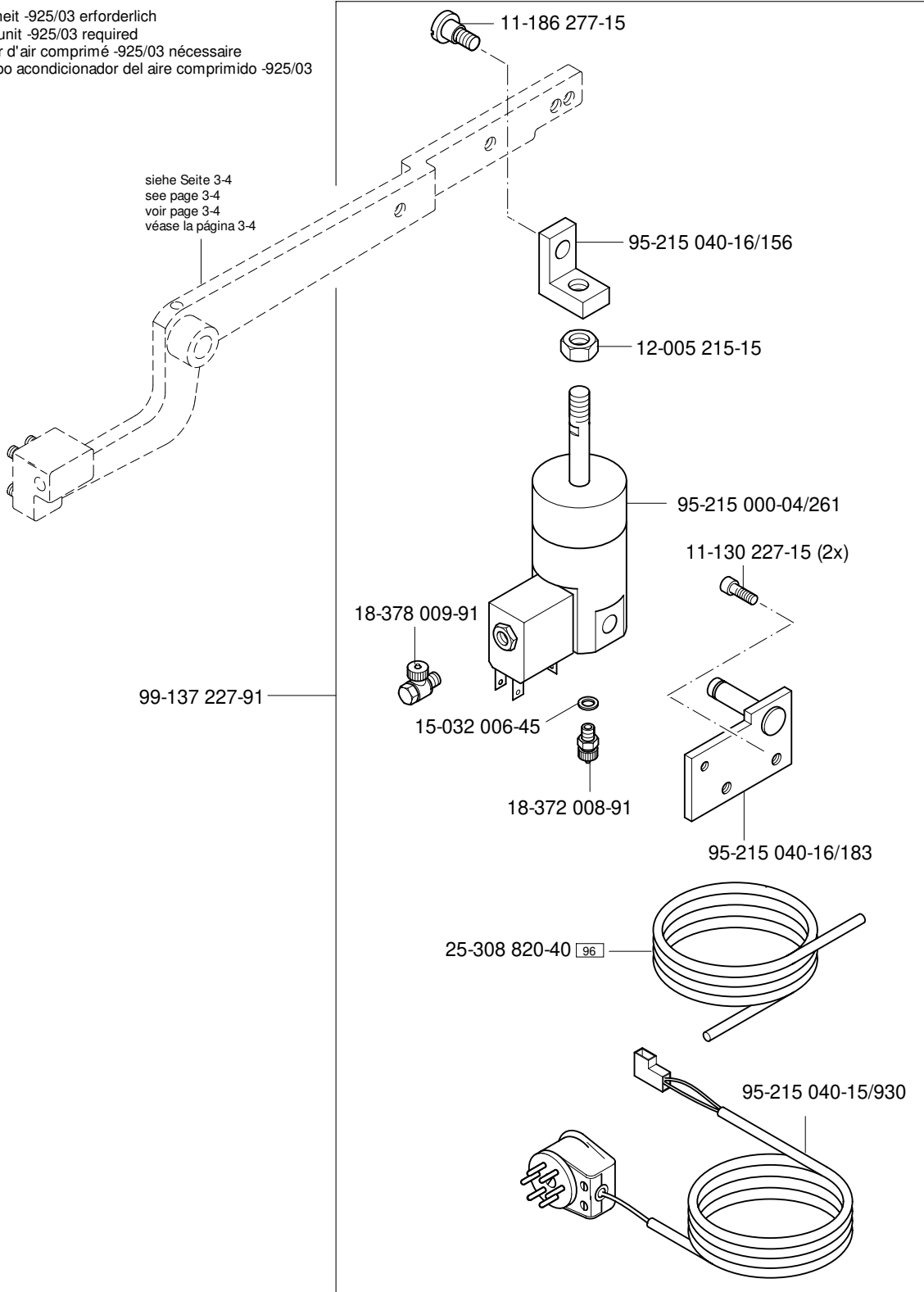

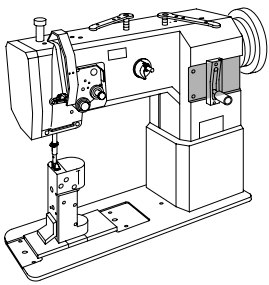

Verriegelungs-Einrichtung (-911/97)
 Backtacking mechanism (-911/97)
 Dispositif à points d'arrêt (-911/97)
 Rematador (-911/97)

PFAFF 1295
 PFAFF 1296

Wartungseinheit -925/03 erforderlich
 Conditioning unit -925/03 required
 Conditionneur d'air comprimé -925/03 nécessaire
 Requiere grupo acondicionador del aire comprimido -925/03

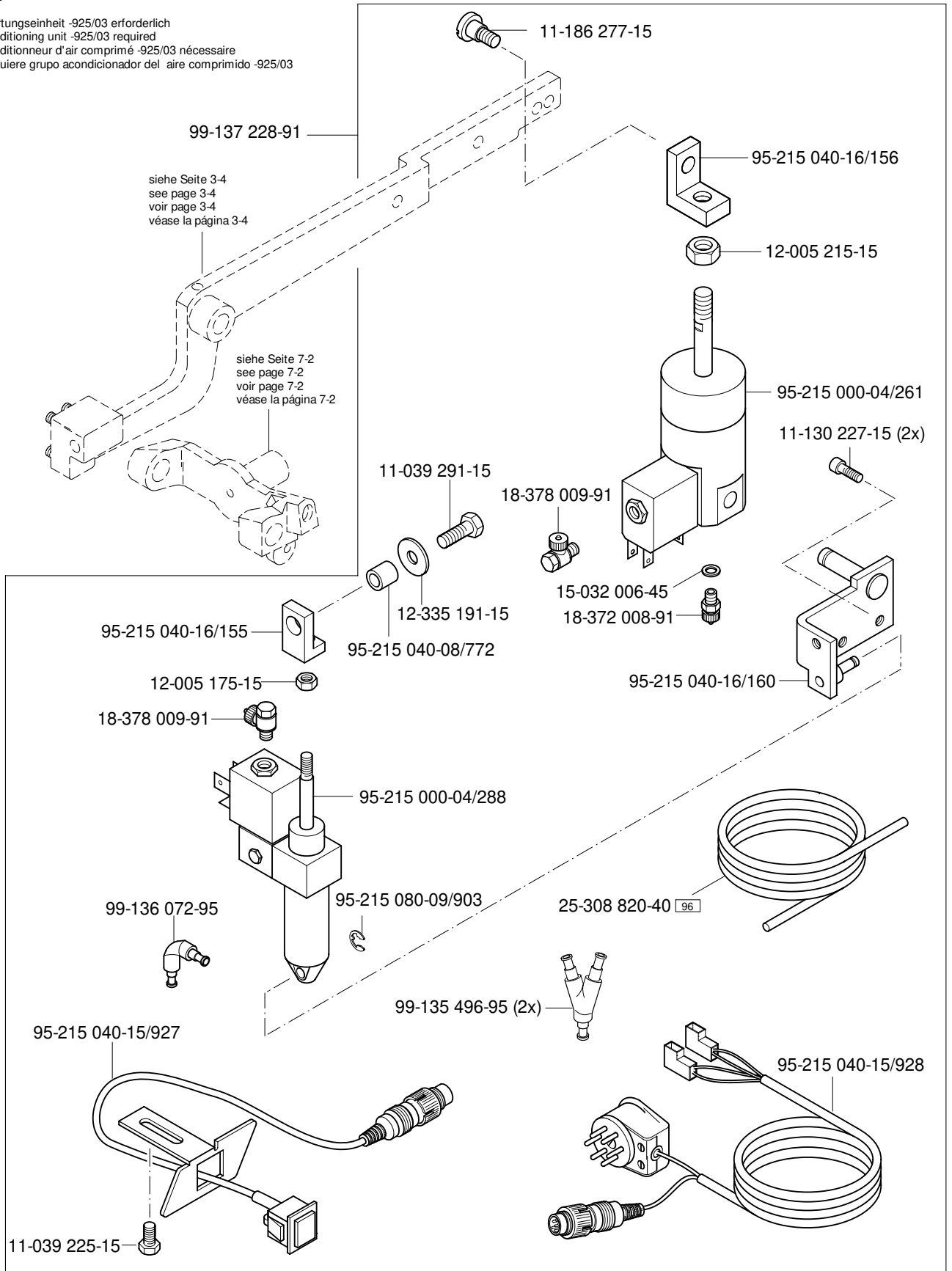

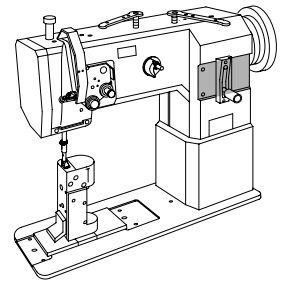

Wartungseinheit -925/03 erforderlich
 Conditioning unit -925/03 required
 Conditionneur d'air comprimé -925/03 nécessaire
 Requiere grupo acondicionador del aire comprimido -925/03

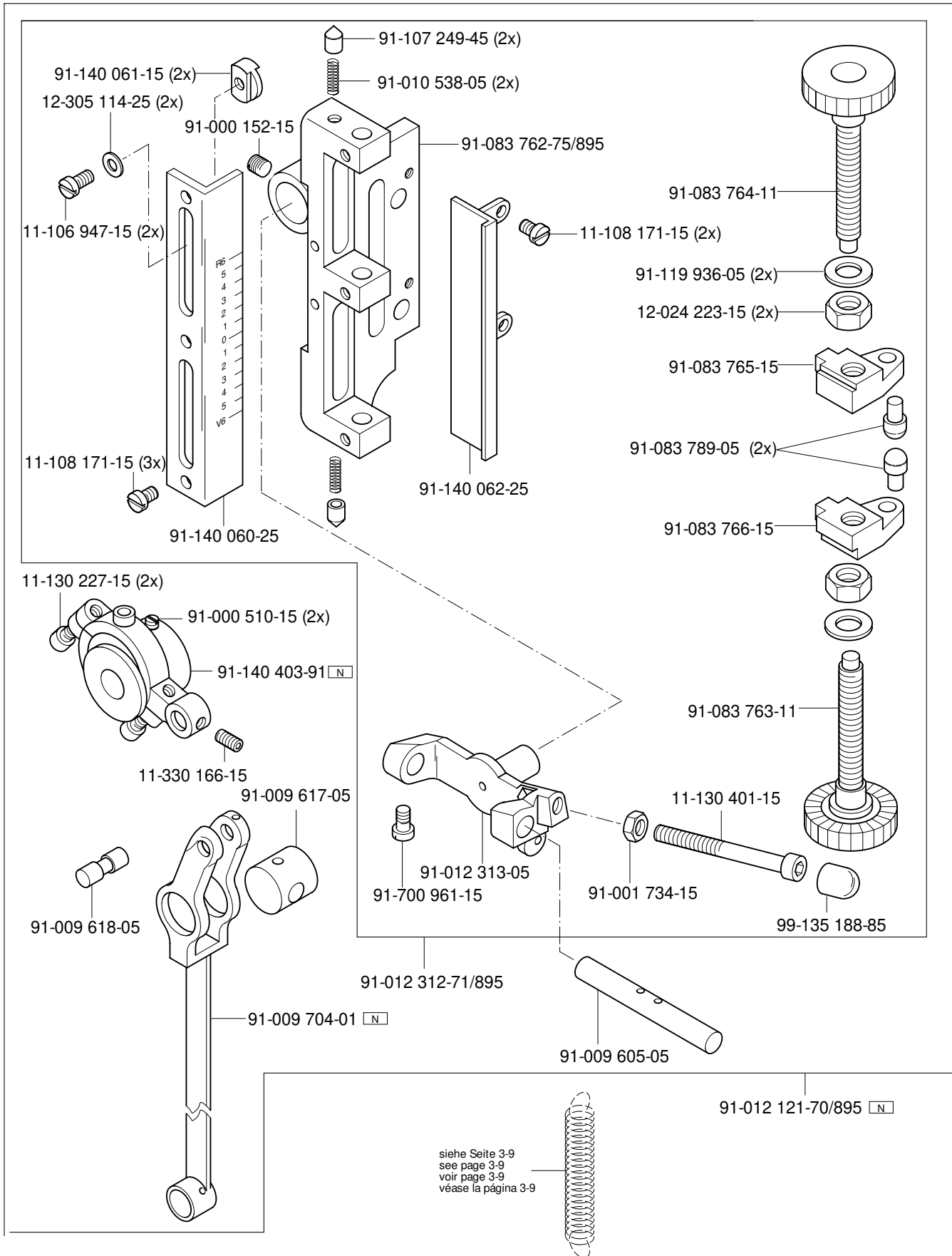

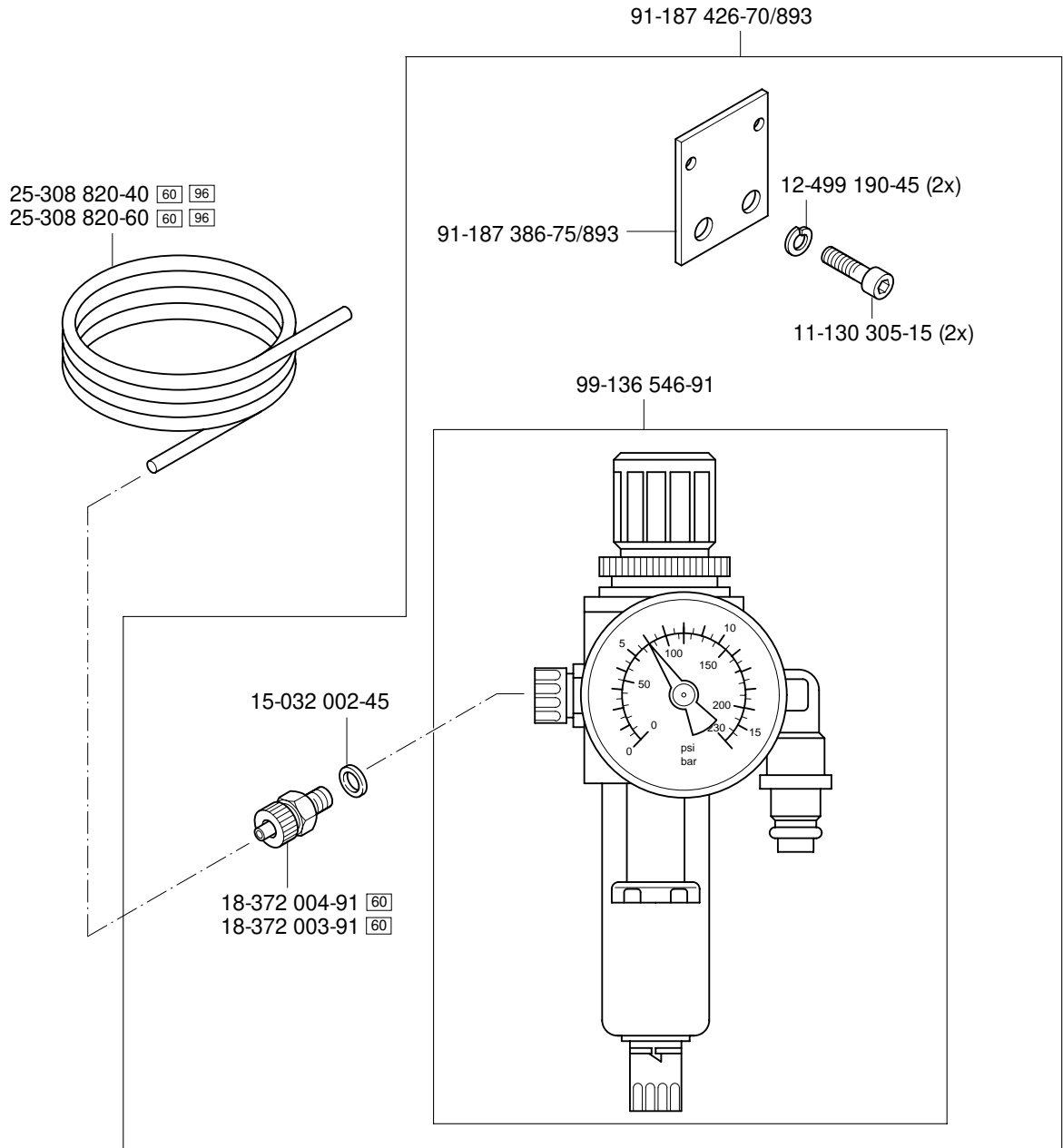

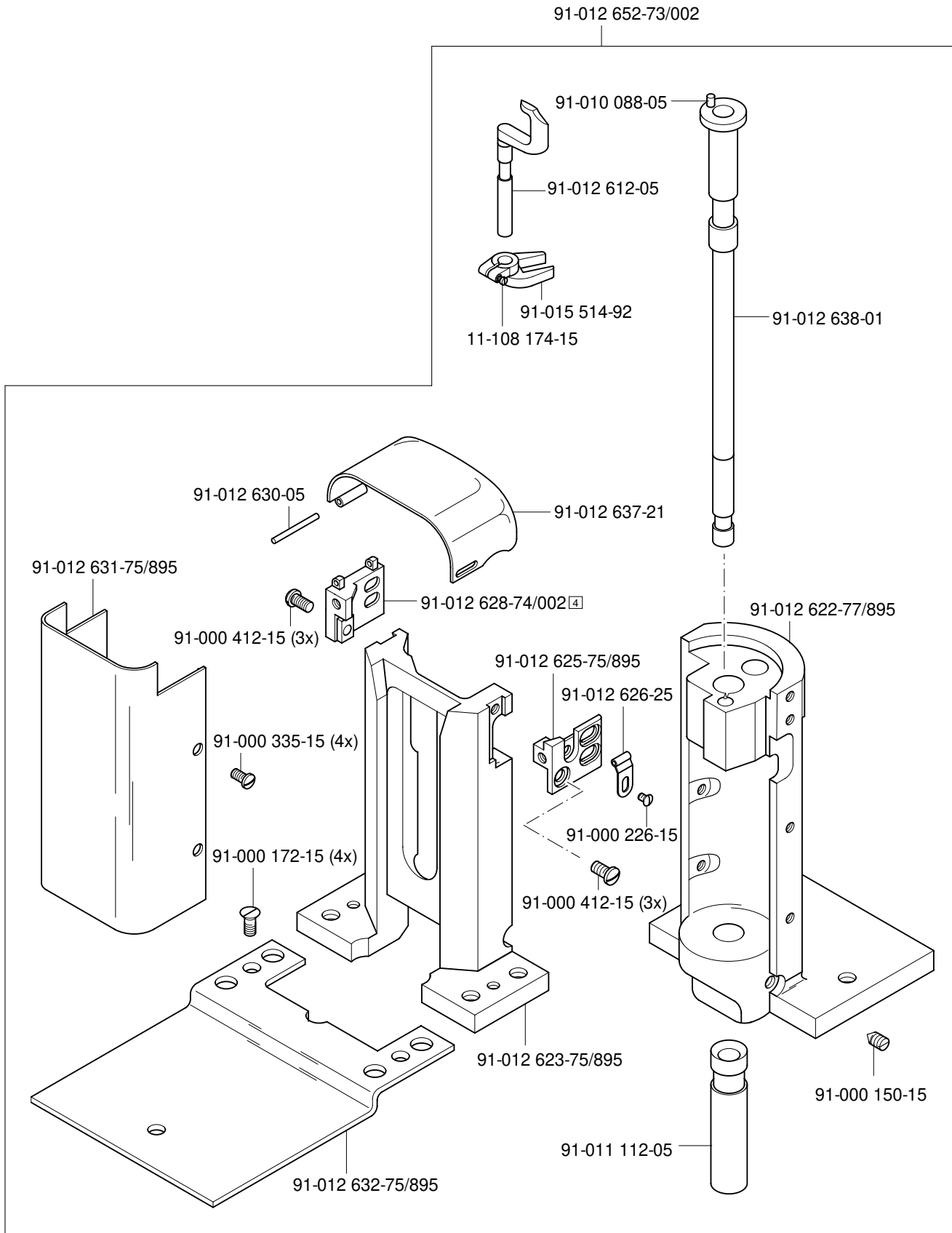

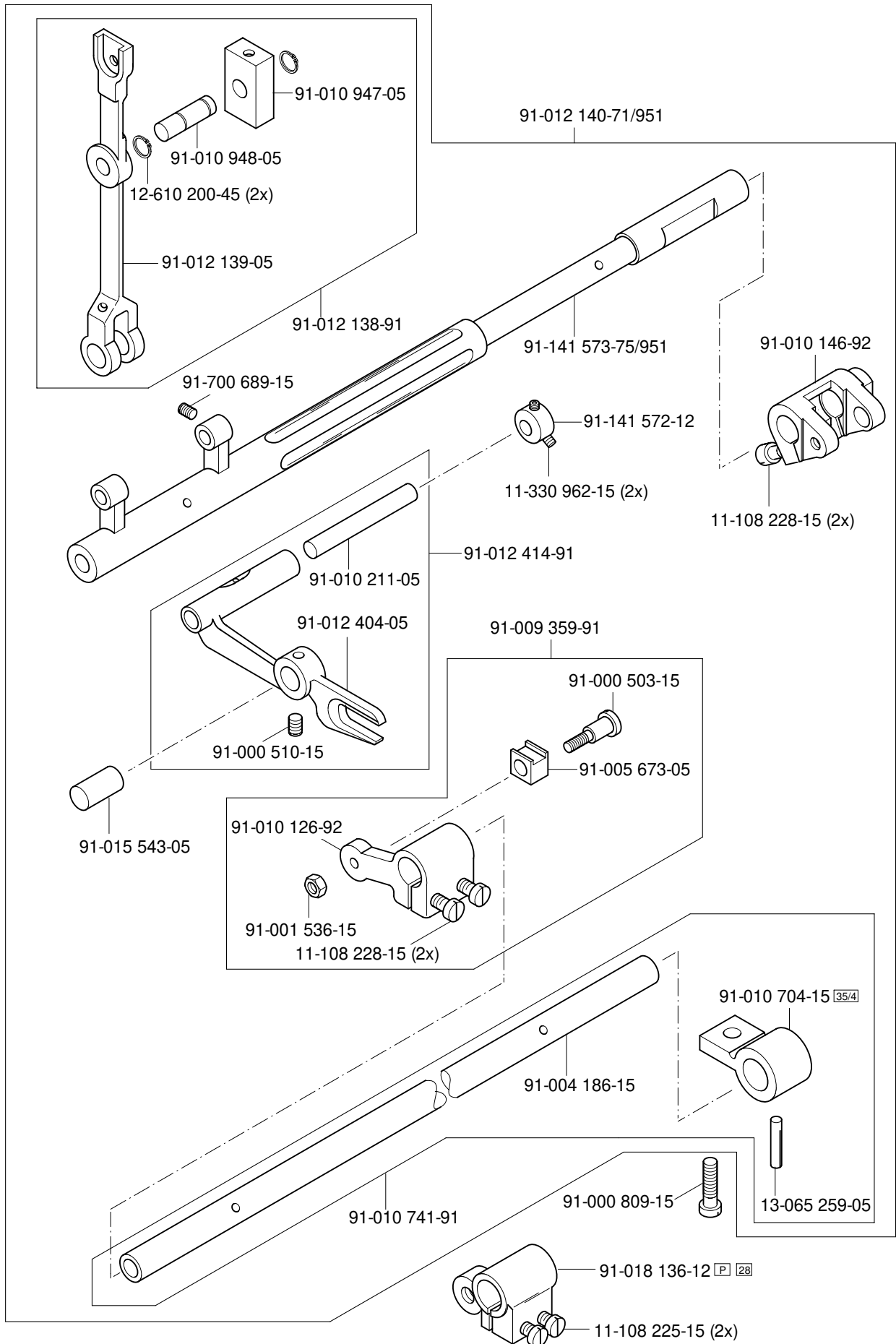

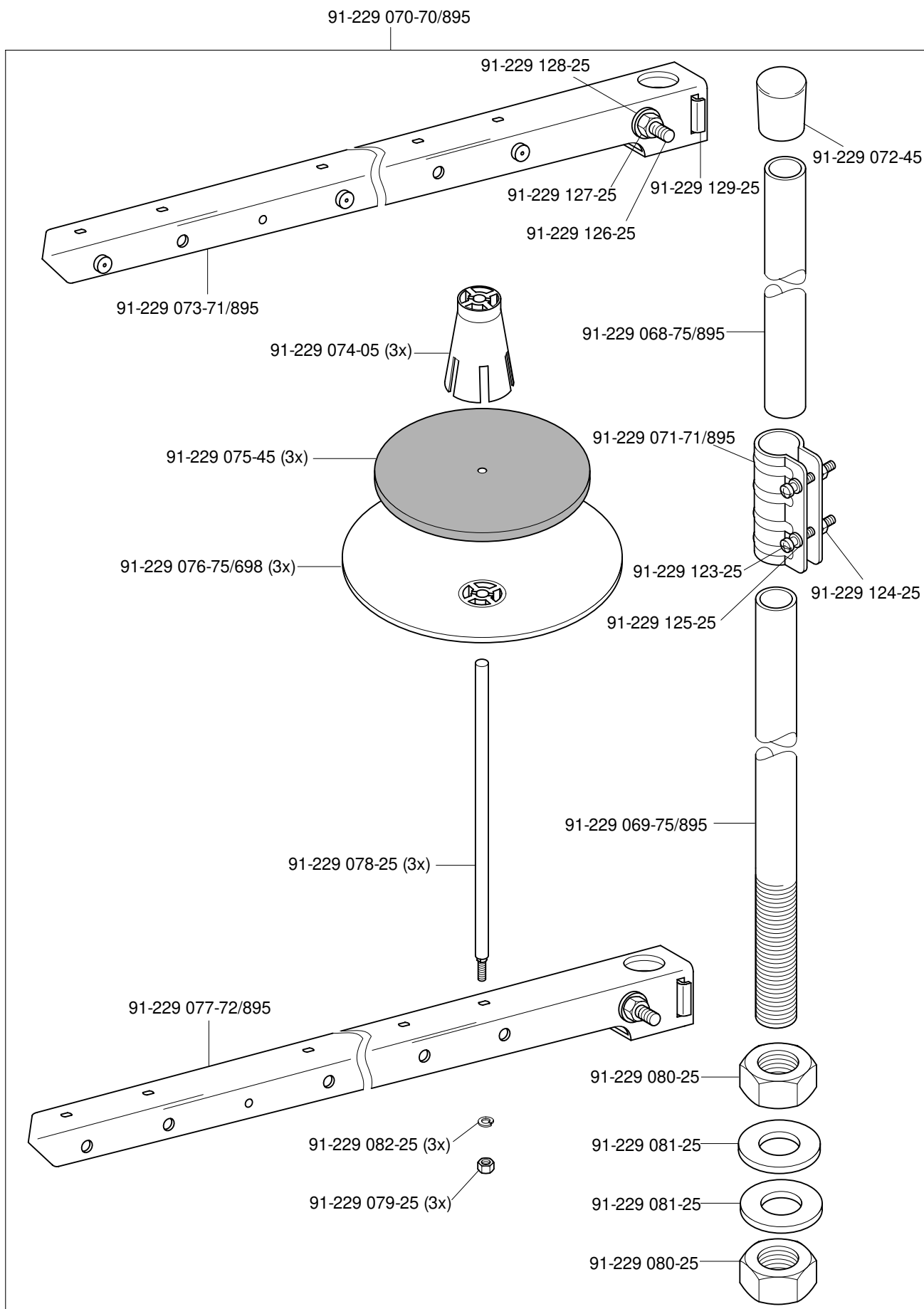

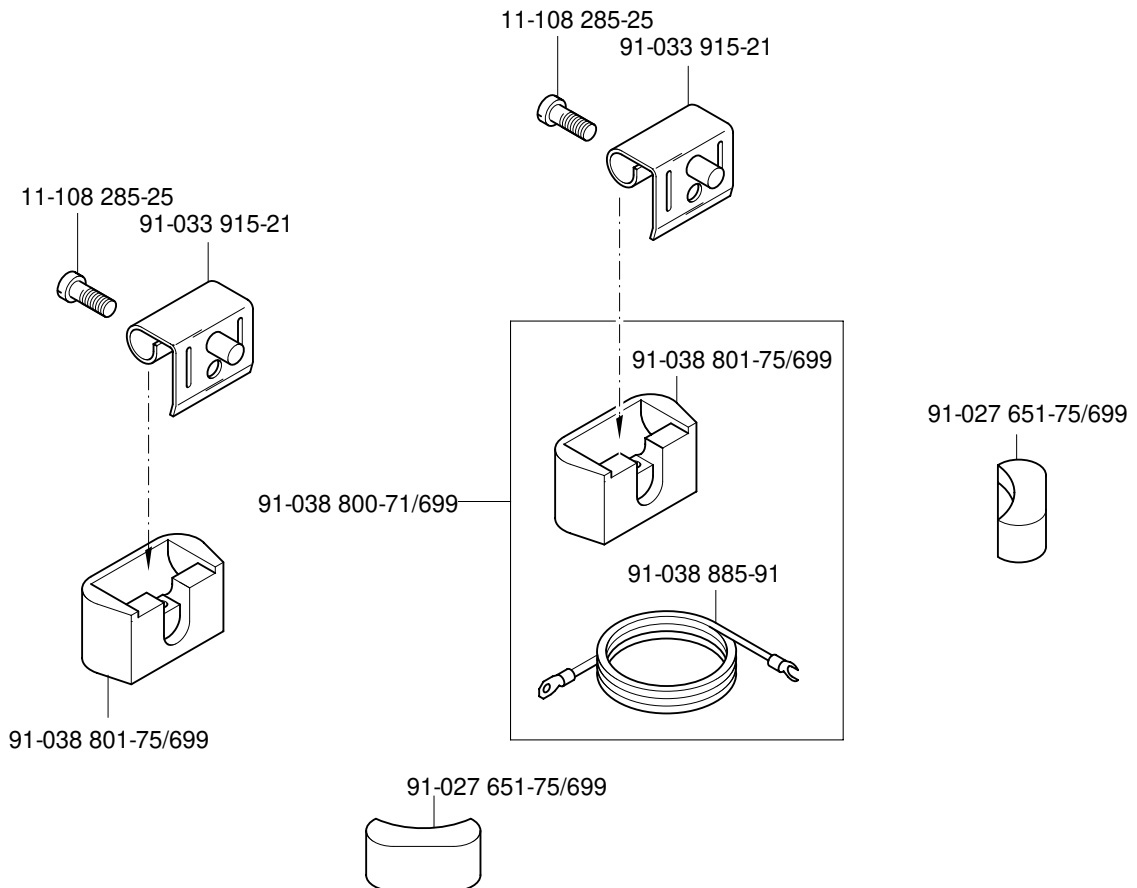
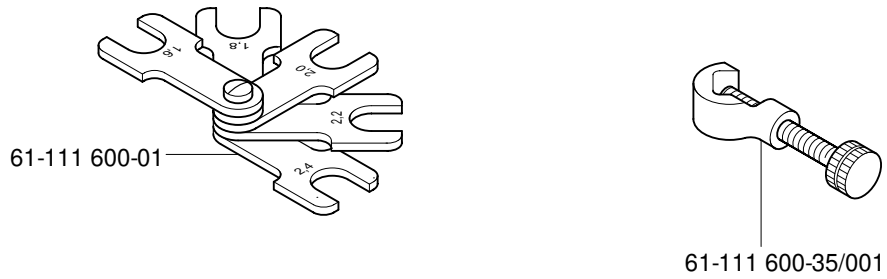

13 Fadenöler
Thread lubricator
Graisseur de fil PFAFF 1295
Lubricador del hilo PFAFF 1296

28

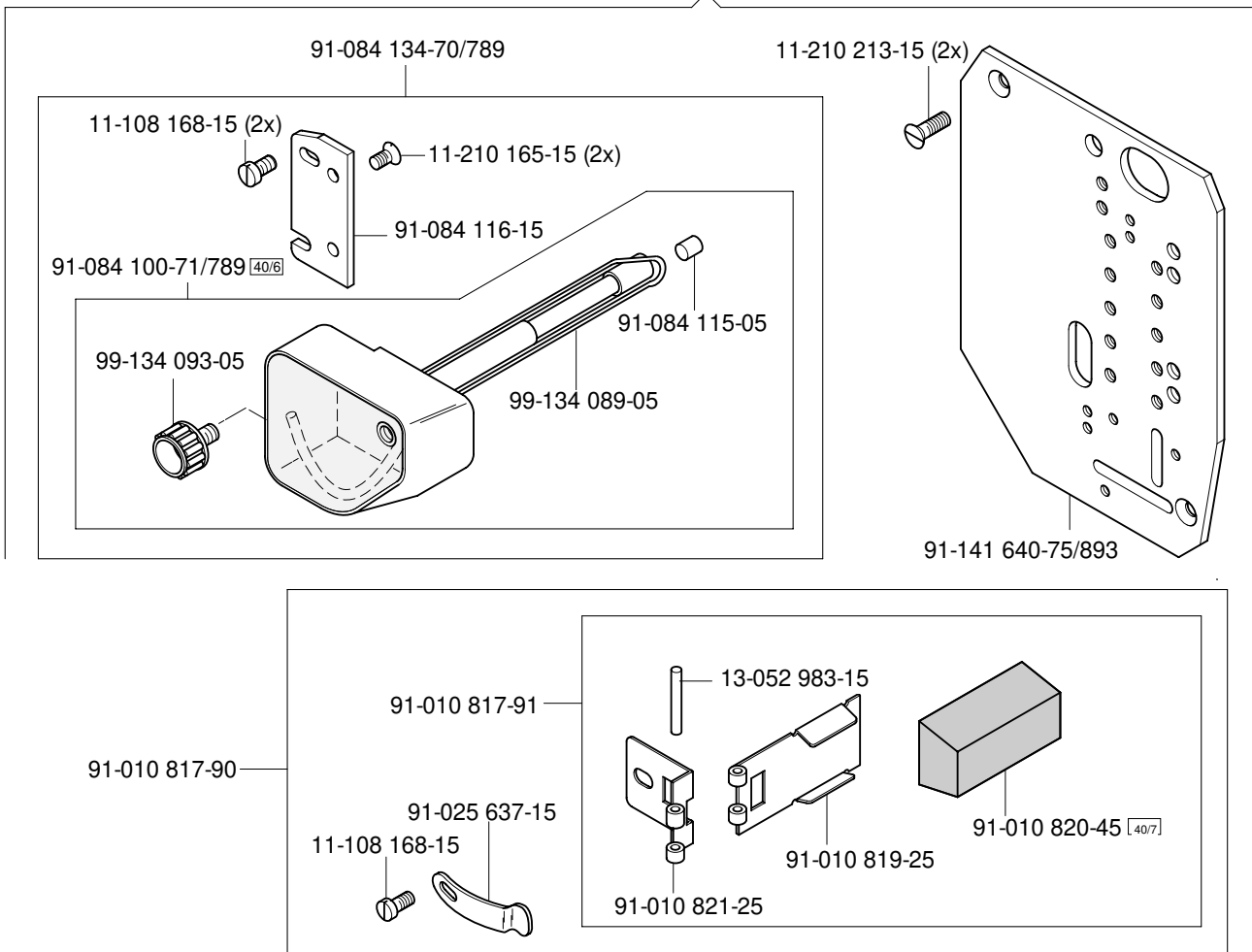

14 Keilriemen
V-belt
Courroie trapézoïdale PFAFF 1295
Correa trapezoidal PFAFF 1296

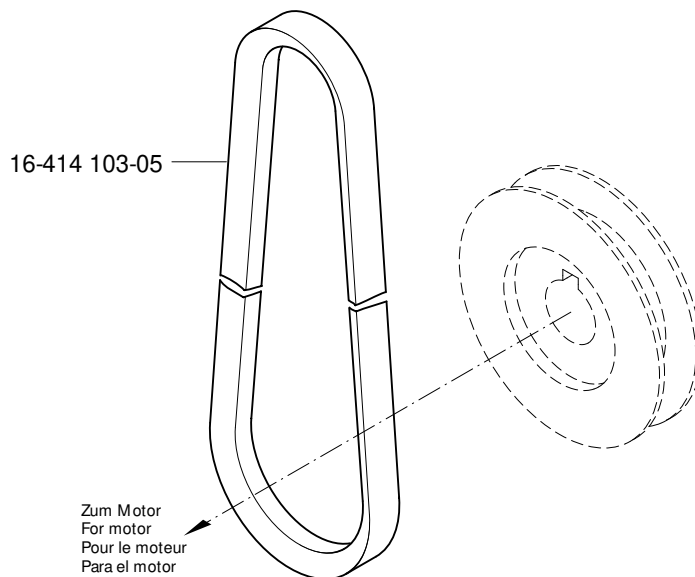

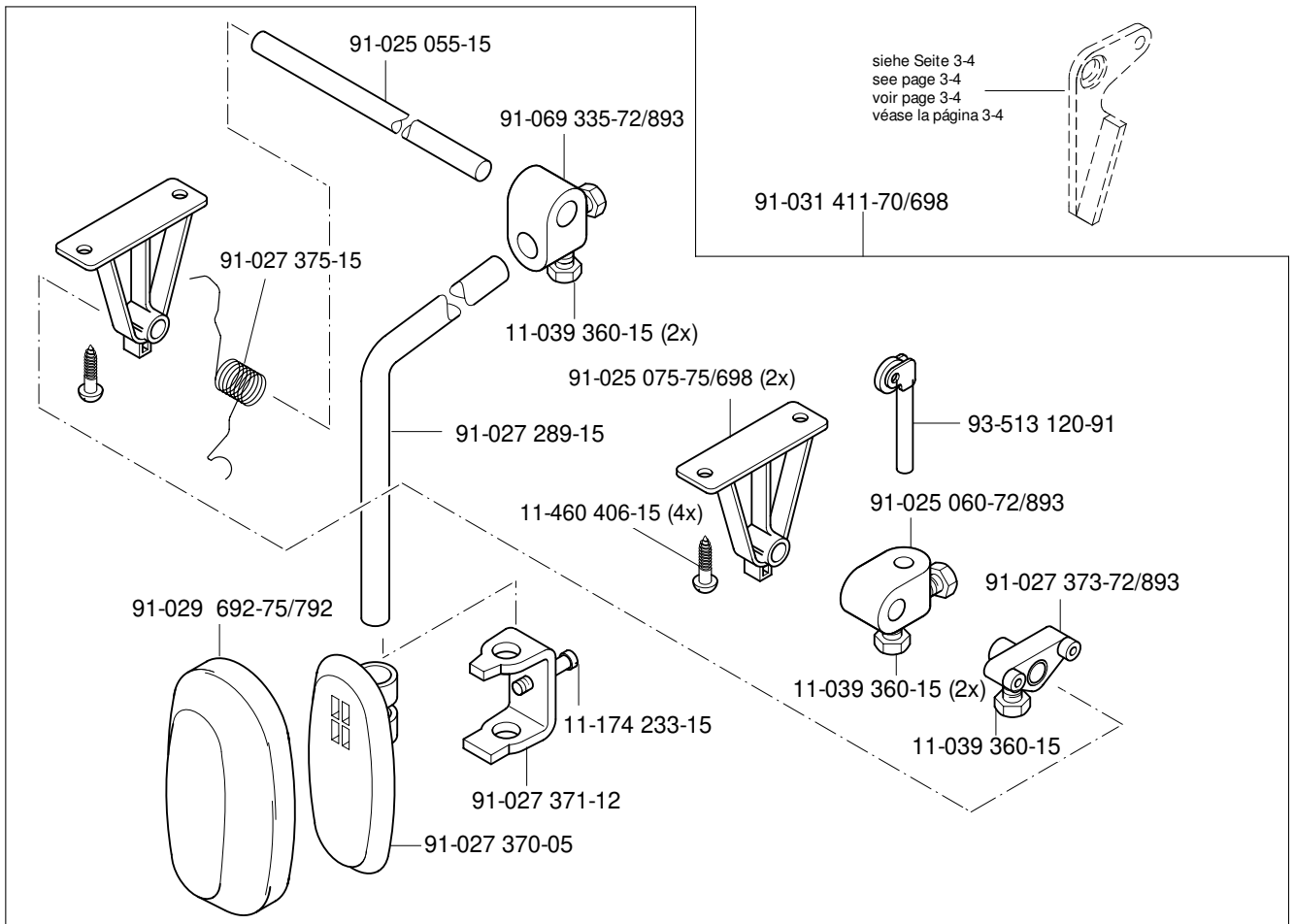
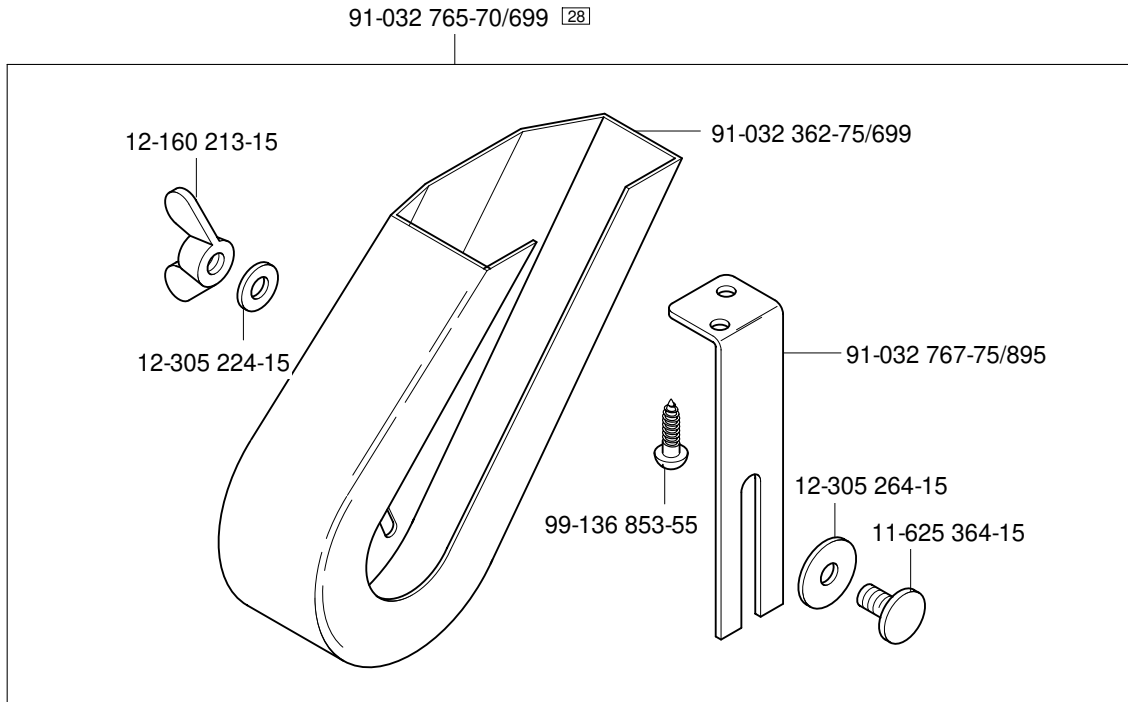

Öl Oil Huile Aceite	Mittelpunkts-Viskosität bei: Mean viscosity at: Viscosité moyenne à: Viscosidad media a:		Dichte bei: Density of: Densité à: Densidad a:		Bestellnummer für Behälter mit: Part number for can with: Numéro de commande pour récipients avec: Número de pedido para recipientes con:		
	°C	mm ² /s	°C	g/cm ³ (g/ml)	1 Liter 1 Litre 1 Litro	5 Liter 5 Litre 5 Litros	10 Liter 10 Litre 10 Litros
28-011 201-44	40	22,0	15	0,865	91-129 917-91	91-129 919-91	91-129 920-91
28-011 202-17 (Fadenschmiermittel) (Thread lubricant) (Agents de lubrication de fil) (Lubricantes del hilo)			21	0,810	91-129 941-91		

Fett Grease Graisse Grasa	Penetration Penetration Pénétration Penetración	Tropfpunkt Drip-point Point de suintement Punto de goteo	Bestellnummer für Behälter mit: Part number for can with: Numéro de commande pour récipients avec: Número de pedido para recipientes con:				
			mm/10	°C	0,25 kg	0,5 kg	1 kg
28-011 202-05							28-011 202-05
28-011 202-43	375 - 405	150				28-011 202-43	
28-011 202-47	220 - 250	185					28-011 202-47

Reinigungsmittel Cleansing agent Agents de nettoyage Limpiadores	Bestellnummer für Behälter mit: Part number for can with: Numéro de commande pour récipients avec: Número de pedido para recipientes con:		
	240 ml		
Isopropyl-Alkohol	95-665 735-91		

No.	Seite Page Pages Página	No.	Seite Page Pages Página	No.	Seite Page Pages Página	No.	Seite Page Pages Página
11-039 171-15	4 - 2, 4 - 3, 4 - 4	11-130 359-15	3 - 8	11-330 968-15	3 - 2	12-341 150-15	3 - 11, 3 - 13
11-039 174-15	4 - 6	11-130 401-15	7 - 2	11-335 902-15	3 - 8, 3 - 16	12-341 151-15	3 - 11, 3 - 13
11-039 222-15	3 - 3	11-130 955-15	3 - 9	11-341 082-15	3 - 3	12-499 190-45	8 - 1
11-039 225-15	3 - 3, 7 - 1	11-173 090-15	4 - 1	11-341 901-15	3 - 8, 3 - 16	12-610 170-45	3 - 2
11-039 291-15	7 - 1	11-173 171-25	3 - 1	11-341 902-15	3 - 8, 3 - 16, 4 - 6	12-610 190-45	3 - 2
11-039 360-15	15 - 1	11-173 177-25	3 - 6	11-460 406-15	15 - 1	12-610 200-45	3 - 2, 3 - 14, 9 - 2
11-106 947-15	7 - 2	11-173 222-25	3 - 1	11-462 118-55	3 - 1	12-610 210-45	3 - 5
11-108 087-15	4 - 2, 4 - 3	11-174 173-15	3 - 2	11-462 247-15	3 - 1	12-618 190-45	4 - 6
11-108 168-15	3 - 1, 4 - 6, 13 - 1	11-174 176-15	3 - 5	11-625 364-15	15 - 1	12-640 090-55	4 - 1
11-108 171-15	3 - 2, 4 - 6, 7 - 2	11-174 233-15	3 - 6, 15 - 1	11-714 060-91	4 - 6	12-640 130-55	3 - 7, 3 - 16, 4 - 6
11-108 174-15	3 - 1, 3 - 3, 3 - 11, 3 - 12, 3 - 13, 4 - 1, 4 - 2, 4 - 3, 4 - 4, 4 - 6, 9 - 1	11-186 277-15	6 - 1, 7 - 1	11-721 482-15	3 - 15	12-640 150-55	3 - 16, 4 - 5, 4 - 6
		11-186 962-15	3 - 9	11-721 522-15	3 - 15	12-640 170-55	4 - 1, 4 - 6
		11-187 017-15	3 - 4	12-005 154-15	3 - 1	12-640 190-55	4 - 6
11-108 177-15	3 - 2	11-210 165-15	13 - 1	12-005 175-15	7 - 1	12-640 230-55	5 - 1
11-108 219-15	4 - 6	11-210 165-25	3 - 6	12-005 195-15	3 - 9, 4 - 5	12-651 006-51	4 - 6
11-108 222-15	3 - 2, 4 - 6	11-210 168-25	3 - 7	12-005 198-15	4 - 5	13-052 187-15	4 - 6
11-108 225-15	3 - 14, 9 - 2	11-210 213-15	13 - 1	12-005 215-15	6 - 1, 7 - 1	13-052 983-15	13 - 1
11-108 228-15	3 - 2, 3 - 3, 3 - 14, 9 - 2	11-210 273-15	3 - 8	12-010 251-15	4 - 6	13-064 383-05	3 - 9
11-108 234-15	3 - 1	11-250 084-25	3 - 7, 3 - 9	12-024 151-15	3 - 1, 4 - 6	13-065 259-05	3 - 14, 9 - 2
11-108 285-15	3 - 1	11-314 946-15	4 - 1	12-024 171-15	3 - 4	14-602 901-01	3 - 7
11-108 285-25	11 - 1	11-315 917-05	3 - 7	12-024 191-15	4 - 6	15-032 002-45	8 - 1
11-108 861-25	4 - 6	11-317 167-15	3 - 6	12-024 191-25	3 - 8	15-032 006-45	6 - 1, 7 - 1
11-130 173-15	3 - 1, 3 - 3	11-317 971-15	4 - 2, 4 - 3, 4 - 4	12-024 192-15	4 - 6	15-711 050-51	3 - 3
11-130 179-15	4 - 5	11-330 166-15	3 - 9, 7 - 2	12-024 223-15	7 - 2	16-414 103-05	13 - 1
11-130 185-15	3 - 3, 4 - 6	11-330 217-15	3 - 16	12-160 213-15	15 - 1	18-372 003-91	8 - 1
11-130 224-15	3 - 2	11-330 220-15	3 - 3, 3 - 6	12-305 114-15	3 - 2, 3 - 3	18-372 004-91	8 - 1
11-130 227-15	3 - 8, 3 - 9, 6 - 1, 7 - 1, 7 - 2	11-330 277-15	4 - 1	12-305 114-25	7 - 2	18-372 008-91	6 - 1, 7 - 1
11-130 254-15	3 - 1	11-330 280-15	3 - 2, 3 - 3, 3 - 5, 3 - 7, 3 - 14, 3 - 16	12-305 144-15	3 - 2, 3 - 8	18-378 009-91	6 - 1, 7 - 1
11-130 284-15	4 - 5	11-330 952-15	3 - 4, 3 - 7, 4 - 2, 4 - 3, 4 - 4	12-305 224-15	15 - 1	25-308 820-40	6 - 1, 7 - 1, 8 - 1
11-130 293-15	3 - 9, 3 - 14, 4 - 6			12-305 264-15	15 - 1	25-308 820-60	8 - 1
11-130 305-15	8 - 1	11-330 962-15	3 - 14, 9 - 2	12-315 110-15	4 - 2, 4 - 3, 4 - 4	26-534 300-50	3 - 5, 3 - 7, 3 - 9
11-130 341-15	5 - 1	11-330 964-15	3 - 15	12-335 191-15	7 - 1	26-535 001-00	3 - 5
				12-341 090-15	4 - 1	28-011 201-44	17 - 1

No.	Seite Page Pages Página	No.	Seite Page Pages Página	No.	Seite Page Pages Página	No.	Seite Page Pages Página
28-011 202-05	17 - 1	91-000 604-15	4 - 2, 4 - 3	91-009 652-91	3 - 6	91-010 937-05	3 - 6
28-011 202-17	17 - 1	91-000 686-15	3 - 11, 3 - 13	91-009 702-02	3 - 9	91-010 947-05	3 - 14, 9 - 2
28-011 202-43	17 - 1	91-000 762-15	3 - 11, 3 - 13	91-009 704-01	3 - 9, 7 - 2	91-010 948-05	3 - 14, 9 - 2
28-011 202-47	17 - 1	91-000 781-15	3 - 11, 3 - 13	91-009 709-05	3 - 9	91-010 950-91	3 - 14
61-111 600-01	11 - 1	91-000 783-15	4 - 2	91-009 717-01	3 - 7	91-011 112-05	3 - 11, 3 - 12, 3 - 13, 4 - 2, 4 - 3, 4 - 4, 9 - 1
61-111 600-35/001	11 - 1	91-000 809-15	9 - 2	91-010 022-05	3 - 9	91-011 778-05	3 - 3
71-170 001-31	4 - 6	91-000 928-15	3 - 10	91-010 026-21	3 - 6		
71-210 001-74	4 - 6	91-001 013-15	3 - 8	91-010 088-05	3 - 11, 3 - 12, 4 - 2, 4 - 3, 4 - 4, 9 - 1	91-011 818-91	3 - 8
71-370 001-32	4 - 6	91-001 512-15	3 - 7, 3 - 9, 3 - 11, 4 - 2	91-010 115-05	3 - 6	91-011 821-91	3 - 16
91-000 011-15	3 - 7	91-001 522-25	3 - 6	91-010 116-05	3 - 6	91-011 823-90	3 - 15
91-000 050-15	3 - 11, 3 - 13	91-001 536-15	3 - 14, 9 - 2	91-010 126-92	3 - 14, 9 - 2	91-011 825-90	3 - 15
91-000 150-15	3 - 11, 3 - 12, 3 - 13, 4 - 2, 4 - 3, 4 - 4, 9 - 1	91-001 734-15	7 - 2	91-010 146-92	3 - 14, 9 - 2	91-011 830-92	4 - 6
91-000 152-15	7 - 2	91-003 113-05	3 - 1	91-010 179-05	3 - 6	91-011 832-75/893	3 - 1
91-000 172-15	3 - 11, 4 - 3, 4 - 4, 9 - 1	91-004 005-05	3 - 6	91-010 180-05	3 - 6	91-011 833-12	4 - 5
91-000 172-25	3 - 11, 3 - 12, 4 - 2	91-004 006-05	3 - 6	91-010 181-25	3 - 6	91-011 848-91	3 - 5
91-000 226-15	9 - 1	91-004 186-15	3 - 14, 9 - 2	91-010 182-05	3 - 6	91-011 944-70/895	3 - 9
91-000 277-25	3 - 11, 3 - 13, 4 - 2, 4 - 3	91-004 309-05	3 - 2	91-010 183-05	3 - 6	91-011 945-71/895	3 - 9
91-000 335-15	9 - 1	91-005 673-05	3 - 14, 9 - 2	91-010 184-05	3 - 6	91-011 954-05	4 - 2, 4 - 3, 4 - 4
91-000 366-15	3 - 6	91-006 505-05	3 - 6	91-010 185-05	3 - 6	91-011 957-15	4 - 2, 4 - 3
91-000 390-05	3 - 10	91-006 616-05	3 - 7, 3 - 9	91-010 186-15	3 - 6	91-011 958-91	4 - 2, 4 - 3
91-000 405-15	3 - 7, 3 - 11	91-007 116-05	3 - 2	91-010 196-05	3 - 7	91-011 963-05	4 - 2, 4 - 3, 4 - 4
91-000 412-15	3 - 11, 3 - 13, 4 - 2, 4 - 3, 9 - 1	91-008 204-05	3 - 9	91-010 211-05	3 - 14, 9 - 2	91-011 964-25	4 - 2, 4 - 3, 4 - 4
91-000 456-15	3 - 7	91-008 618-05	3 - 7, 3 - 9	91-010 221-05	3 - 14	91-011 966-15	4 - 6
91-000 486-15	3 - 13, 4 - 3	91-009 148-05	3 - 5	91-010 538-05	7 - 2	91-011 967-15	4 - 6
91-000 503-15	3 - 14, 9 - 2	91-009 149-05	3 - 14	91-010 596-05	3 - 7, 3 - 9	91-011 968-15	4 - 6
91-000 510-15	3 - 7, 3 - 9, 3 - 14, 7 - 2, 9 - 2	91-009 343-05	3 - 16	91-010 704-15	3 - 14, 9 - 2	91-011 969-05	4 - 6
91-000 511-15	3 - 7	91-009 359-91	3 - 14, 9 - 2	91-010 741-91	9 - 2	91-011 970-01	4 - 6
91-000 522-15	3 - 9	91-009 408-05	3 - 16	91-010 817-90	13 - 1	91-011 974-15	4 - 6
91-000 524-05	3 - 6	91-009 603-75/895	3 - 9	91-010 817-91	13 - 1	91-011 975-15	4 - 6
91-000 525-15	3 - 10	91-009 605-05	3 - 9, 7 - 2	91-010 819-25	13 - 1	91-011 976-15	4 - 6
91-000 529-15	3 - 10	91-009 609-05	3 - 9	91-010 820-45	13 - 1	91-011 977-11	4 - 6
		91-009 617-05	3 - 9, 7 - 2	91-010 821-25	13 - 1	91-011 979-15	4 - 6
		91-009 618-05	3 - 9, 7 - 2	91-010 825-05	3 - 2	91-011 980-05	4 - 6

No.	Seite Page Pages Página	No.	Seite Page Pages Página	No.	Seite Page Pages Página	No.	Seite Page Pages Página
91-011 981-05	4 - 6	91-012 612-05	3 - 11, 3 - 12, 3 - 13, 9 - 1	91-017 378-15	4 - 1	91-018 993-74/002	4 - 2
91-011 982-11	4 - 6	91-012 622-77/895	9 - 1	91-018 136-12	3 - 14, 9 - 2	91-018 994-74/002	4 - 2
91-011 985-15	4 - 6	91-012 623-75/895	9 - 1	91-018 257-05	4 - 2, 4 - 3, 4 - 4	91-018 997-21	4 - 2, 4 - 3, 4 - 4
91-011 991-91	4 - 6	91-012 625-75/895	9 - 1	91-018 268-73/001	4 - 3	91-018 998-75/895	4 - 2, 4 - 3, 4 - 4
91-011 992-15	4 - 6	91-012 626-25	9 - 1	91-018 268-73/002	4 - 3	91-018 999-05	4 - 2, 4 - 3, 4 - 4
91-011 993-15	4 - 6	91-012 628-74/002	9 - 1	91-018 269-73/002	4 - 2	91-019 676-05	3 - 5, 3 - 7, 3 - 9
91-011 995-91	4 - 5	91-012 630-05	9 - 1	91-018 284-91	3 - 10	91-019 891-05	3 - 10
91-011 996-12	4 - 5	91-012 631-75/895	9 - 1	91-018 285-91	3 - 10	91-021 202-05	4 - 2, 4 - 3, 4 - 4
91-012 096-15	4 - 2, 4 - 3	91-012 632-75/895	9 - 1	91-018 293-05	3 - 10	91-021 283-05	4 - 6
91-012 097-91	4 - 6	91-012 637-21	9 - 1	91-018 339-05	3 - 10	91-021 486-41	5 - 1
91-012 100-05	4 - 3	91-012 638-01	3 - 11, 3 - 12, 4 - 2, 4 - 3, 4 - 4, 9 - 1	91-018 340-91	3 - 10	91-025 055-15	15 - 1
91-012 108-91	4 - 6	91-012 644-05	3 - 11, 3 - 13	91-018 341-91	3 - 10	91-025 060-72/893	15 - 1
91-012 112-15	4 - 6	91-012 652-73/002	9 - 1	91-018 344-05	3 - 10	91-025 075-75/698	15 - 1
91-012 113-05	4 - 5	91-012 653-73/001	3 - 13	91-018 346-01	3 - 10	91-025 637-15	13 - 1
91-012 115-25	4 - 2, 4 - 3	91-012 695-75/895	3 - 13, 4 - 3	91-018 348-91	3 - 10	91-027 289-15	15 - 1
91-012 121-70/895	7 - 2	91-012 696-75/895	3 - 12, 4 - 3, 4 - 4	91-018 349-05	3 - 10	91-027 370-05	15 - 1
91-012 138-91	9 - 2	91-012 697-74/001	3 - 13	91-018 350-05	3 - 10	91-027 371-12	15 - 1
91-012 139-05	9 - 2	91-012 698-73/002	3 - 11	91-018 358-75/770	3 - 7	91-027 373-72/893	15 - 1
91-012 140-71/951	9 - 2	91-013 040-92	3 - 7	91-018 415-92	3 - 7	91-027 375-15	15 - 1
91-012 272-11	4 - 6	91-013 091-05	3 - 6	91-018 439-05	3 - 10	91-027 651-75/699	11 - 1
91-012 312-71/895	7 - 2	91-013 153-05	3 - 16	91-018 480-05	3 - 10	91-029 692-75/792	15 - 1
91-012 313-05	7 - 2	91-013 188-05	3 - 16	91-018 481-05	3 - 10	91-031 411-70/698	15 - 1
91-012 404-05	3 - 14, 9 - 2	91-013 191-05	3 - 6	91-018 482-91	3 - 10	91-032 087-45	3 - 1
91-012 414-91	3 - 14, 9 - 2	91-013 193-91	3 - 6	91-018 483-91	3 - 10	91-032 362-75/699	15 - 1
91-012 453-75/895	3 - 11	91-015 514-92	3 - 11, 3 - 12, 3 - 13, 4 - 2, 4 - 3, 4 - 4, 9 - 1	91-018 484-05	3 - 10	91-032 765-70/699	15 - 1
91-012 492-25	3 - 9	91-015 519-05	3 - 6	91-018 487-05	3 - 8	91-032 767-75/895	15 - 1
91-012 604-75/895	3 - 11, 4 - 2	91-015 533-05	3 - 13, 4 - 3	91-018 515-01	3 - 7, 3 - 9	91-033 915-21	11 - 1
91-012 605-74/002	3 - 11	91-015 542-05	3 - 14	91-018 649-01	3 - 10	91-038 800-71/699	11 - 1
91-012 606-74/012	3 - 11	91-015 543-05	3 - 14, 9 - 2	91-018 676-91	3 - 10	91-038 801-75/699	11 - 1
91-012 607-75/895	3 - 11, 4 - 2	91-015 657-01	3 - 8	91-018 682-05	3 - 10	91-038 885-91	11 - 1
91-012 608-75/895	3 - 11, 4 - 2	91-015 664-05	3 - 14	91-018 799-91	3 - 6	91-056 192-25	3 - 8
91-012 609-25	3 - 11, 3 - 13			91-018 992-74/001	4 - 3	91-056 193-25	3 - 8
91-012 611-77/895	3 - 11, 3 - 12, 3 - 13			91-018 992-74/002	4 - 3	91-056 578-91	3 - 8

No.	Seite Page Pages Página	No.	Seite Page Pages Página	No.	Seite Page Pages Página	No.	Seite Page Pages Página
91-057 720-15	3 - 2	91-113 023-92	4 - 1	91-140 325-91	3 - 5	91-141 101-15	3 - 2
91-063 048-05	3 - 2, 3 - 5	91-113 027-15	4 - 1	91-140 327-91	3 - 5	91-141 102-05	3 - 2
91-063 051-01	3 - 5	91-118 099-91	3 - 7	91-140 336-15	3 - 4	91-141 307-05	3 - 3
91-069 037-15	3 - 16	91-118 196-12	3 - 2	91-140 342-01	3 - 3	91-141 312-71/951	3 - 3
91-069 043-15	3 - 5	91-118 430-25	3 - 6	91-140 347-01	3 - 2	91-141 313-75/951	3 - 3
91-069 335-72/893	15 - 1	91-118 681-05	3 - 7	91-140 349-05	3 - 2, 3 - 3	91-141 314-71/951	3 - 3
91-069 709-12	4 - 2, 4 - 3, 4 - 4	91-118 683-05	3 - 7	91-140 351-91	3 - 2	91-141 315-75/951	3 - 3
91-083 762-75/895	7 - 2	91-118 685-05	3 - 7	91-140 352-05	3 - 2	91-141 429-15	3 - 1
91-083 763-11	7 - 2	91-118 940-05	3 - 7	91-140 353-05	3 - 2	91-141 430-15	3 - 1
91-083 764-11	7 - 2	91-119 421-05	3 - 2	91-140 358-05	3 - 2	91-141 442-15	3 - 6
91-083 765-15	7 - 2	91-119 590-05	3 - 9	91-140 359-05	3 - 2	91-141 443-15	3 - 6
91-083 766-15	7 - 2	91-119 936-05	7 - 2	91-140 360-05	3 - 2	91-141 452-12	3 - 8
91-083 789-05	7 - 2	91-120 735-92	3 - 16	91-140 363-12	3 - 2	91-141 455-91	3 - 8
91-084 100-71/789	13 - 1	91-129 805-90	3 - 1	91-140 366-05	3 - 2	91-141 502-15	3 - 2
91-084 115-05	13 - 1	91-129 917-91	17 - 1	91-140 367-05	3 - 2	91-141 558-05	4 - 2, 4 - 4
91-084 116-15	13 - 1	91-129 919-91	17 - 1	91-140 368-01	3 - 2	91-141 572-12	3 - 14, 9 - 2
91-084 134-70/789	13 - 1	91-129 920-91	17 - 1	91-140 372-05	3 - 2	91-141 573-75/951	3 - 14, 9 - 2
91-095 850-91	4 - 6	91-129 941-91	17 - 1	91-140 378-05	3 - 3	91-141 612-91	3 - 8
91-099 904-45	4 - 6	91-140 060-25	7 - 2	91-140 379-92	3 - 3	91-141 617-75/698	3 - 1
91-100 281-25	3 - 7	91-140 061-15	7 - 2	91-140 394-05	3 - 2	91-141 618-75/895	3 - 1
91-100 351-25	4 - 2, 4 - 3, 4 - 4	91-140 062-25	7 - 2	91-140 403-91	3 - 9, 7 - 2	91-141 619-05	3 - 7
91-100 366-15	3 - 2	91-140 068-75/951	3 - 4	91-140 450-25	3 - 2	91-141 620-72/893	3 - 8
91-105 005-15	3 - 3	91-140 085-05	3 - 3	91-140 481-01	3 - 8	91-141 621-75/895	3 - 1
91-105 447-25	3 - 6	91-140 086-12	3 - 3	91-140 516-75/770	3 - 7, 3 - 15	91-141 622-75/698	3 - 1
91-107 162-15	4 - 1	91-140 101-05	3 - 7	91-140 560-90	3 - 16	91-141 623-75/698	3 - 1
91-107 249-45	7 - 2	91-140 102-05	3 - 7	91-140 561-91	3 - 16	91-141 624-75/895	3 - 1
91-107 933-15	4 - 5	91-140 120-05	3 - 8	91-140 562-05	3 - 16	91-141 625-75/895	5 - 1
91-107 935-11	4 - 5	91-140 123-91	3 - 8	91-140 563-05	3 - 16	91-141 626-05	3 - 4
91-107 939-15	4 - 5	91-140 149-15	3 - 1	91-140 564-92	3 - 16	91-141 628-75/895	3 - 1
91-108 015-02	3 - 7	91-140 201-05	3 - 15	91-140 582-15	5 - 1	91-141 633-15	4 - 1
91-113 017-91	3 - 6	91-140 202-05	3 - 15	91-141 087-05	3 - 16	91-141 640-75/893	13 - 1
91-113 019-15	4 - 1	91-140 273-05	3 - 3, 3 - 5	91-141 099-05	3 - 3	91-141 663-15	3 - 4
91-113 020-25	4 - 1	91-140 292-91	3 - 3	91-141 100-91	3 - 2	91-141 664-75/895	3 - 1

No.	Seite Page Pages Página	No.	Seite Page Pages Página	No.	Seite Page Pages Página	No.	Seite Page Pages Página
91-141 665-91	3 - 3	91-175 023-05	3 - 16	91-229 144-75/895	3 - 1	99-135 585-05	3 - 8
91-141 666-05	3 - 3	91-175 126-05	3 - 16	91-229 145-75/895	3 - 1	99-136 072-95	7 - 1
91-141 667-05	3 - 3	91-175 171-05	4 - 1	91-229 146-75/895	3 - 1	99-136 546-91	8 - 1
91-141 668-15	3 - 2	91-176 267-05	3 - 2	91-266 397-01	3 - 7	99-136 853-55	15 - 1
91-141 669-15	3 - 6	91-176 327-05	4 - 1	91-700 029-15	3 - 4	99-137 001-05	3 - 1
91-141 674-05	3 - 9	91-176 328-05	4 - 1	91-700 082-15	3 - 6	99-137 151-45	3 - 7
91-141 679-71/698	3 - 9	91-176 329-05	4 - 1	91-700 364-25	3 - 1	99-137 227-91	6 - 1
91-141 688-90	3 - 1	91-176 332-25	3 - 6	91-700 412-25	3 - 6	99-137 228-91	7 - 1
91-141 694-05	3 - 3	91-187 386-75/893	8 - 1	91-700 510-15	3 - 3		
91-141 710-72/893	3 - 8	91-187 426-70/893	8 - 1	91-700 592-15	3 - 4		
91-141 760-15	4 - 1	91-229 068-75/895	10 - 1	91-700 689-15	3 - 7, 3 - 14, 3 - 16, 9 - 2		
91-141 818-15	3 - 4	91-229 069-75/895	10 - 1	91-700 785-15	3 - 15, 4 - 6		
91-141 829-92	3 - 4	91-229 070-70/895	10 - 1	91-700 961-15	3 - 9, 7 - 2		
91-141 831-15	3 - 4	91-229 071-71/895	10 - 1	91-701 344-15	4 - 2, 4 - 3		
91-141 848-91	3 - 2	91-229 072-45	10 - 1	91-709 610-71/698	3 - 9		
91-141 850-91	3 - 2	91-229 073-71/895	10 - 1	91-513 120-91	15 - 1		
91-141 851-91	3 - 2	91-229 074-05	10 - 1	95-215 000-04/261	6 - 1, 7 - 1		
91-141 852-91	3 - 2	91-229 075-45	10 - 1	95-215 000-04/288	7 - 1		
91-141 853-91	3 - 3	91-229 076-75/698	10 - 1	95-215 040-08/772	7 - 1		
91-166 452-21	3 - 8	91-229 077-72/895	10 - 1	95-215 040-15/927	7 - 1		
91-166 559-25	3 - 6	91-229 078-25	10 - 1	95-215 040-15/928	7 - 1		
91-166 670-15	3 - 1	91-229 079-25	10 - 1	95-215 040-15/930	6 - 1		
91-168 154-05	4 - 6	91-229 080-25	10 - 1	95-215 040-16/155	7 - 1		
91-168 319-12	3 - 15, 4 - 6	91-229 081-25	10 - 1	95-215 040-16/156	6 - 1, 7 - 1		
91-168 480-15	3 - 8	91-229 082-25	10 - 1	95-215 040-16/160	7 - 1		
91-169 523-05	3 - 3	91-229 123-25	10 - 1	95-215 040-16/183	6 - 1		
91-171 042-05	3 - 7	91-229 124-25	10 - 1	95-215 080-09/903	7 - 1		
91-171 049-05	3 - 7	91-229 125-25	10 - 1	95-665 735-91	17 - 1		
91-171 653-05	4 - 6	91-229 126-25	10 - 1	96-711 962-05	3 - 2		
91-171 808-05	3 - 2	91-229 127-25	10 - 1	99-134 089-05	13 - 1		
91-173 664-15	3 - 3	91-229 128-25	10 - 1	99-134 093-05	13 - 1		
91-174 783-05	3 - 7	91-229 129-25	10 - 1	99-135 188-85	7 - 2		
91-174 879-05	3 - 8	91-229 143-70/895	3 - 1	99-135 496-95	7 - 1		

PFAFF

1295

1296

Unterklassen-Ausstattung

Subclass parts

Composition des sous-classes

Composición de las subclases

-6/01 CN♦

Für allgemeine Näharbeiten.
Standardform des Teilesatzes.

For ordinary sewing operations.
Standard part set.

Travaux d'utilité courante.
Jeu de pièces standard.

Para trabajos de costura en general.
Juego de piezas estándar.

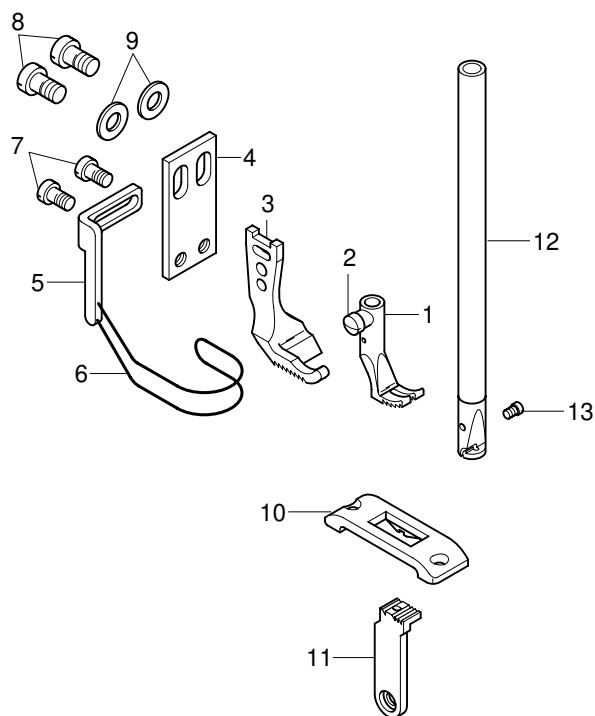

Pos.-Nr. Item No. N° pos. N° de pos.	Teile-Nr. Part No. N° de piezas N° de pieza
1 - 11	91-202 136-93/001
1 - 2	91-049 269-93/006
2	91-000 085-25
3	91-049 585-04/004
4 - 7	91-057 721-91
4	91-057 720-15
5 - 6	91-057 697-91
5	91-154 702-15
6	91-055 205-05 [3]
7	11-108 171-15
8	11-108 222-15
9	12-305 144-15
10	91-048 319-04/002
11	91-045 601-04/002
12 - 13	91-710 650-92
13	91-173 664-15

-6/01-900/56 CN♦

Für allgemeine Näharbeiten.
Standardform des Teilesatzes.

For ordinary sewing operations.
Standard part set.

Travaux d'utilité courante.
Jeu de pièces standard.

Para trabajos de costura en general.
Juego de piezas estándar.

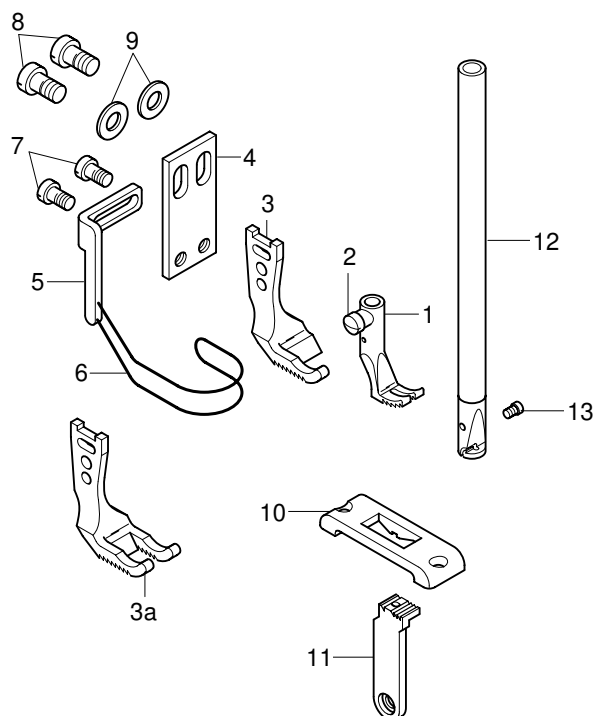

Pos.-Nr. Item No. N° pos. N° de pos.	Teile-Nr. Part No. N° de piezas N° de pieza
1 - 11	91-202 137-93/001 91-202 137-93/002 [28]
1 - 2	91-049 269-93/006
2	91-000 085-25
3	91-049 585-04/004
3a	91-046 970-05 [28]
4 - 7	91-057 721-91
4	91-057 720-15
5 - 6	91-057 697-91
5	91-154 702-15
6	91-055 205-05 [3]
7	11-108 171-15
8	11-108 222-15
9	12-305 144-15
10	91-158 292-05
11	91-059 254-04/001
12 - 13	91-710 650-92
13	91-173 664-15

-6/37-900/56 CN♦

Zum Übersteppen von Seiten-
 nähten im Hüftbogenbereich
 bei Jeans etc., Spezialteilensatz
 mit Anschlägen für rechte und
 linke Teile.

For top-stitching side seams in
 the hip curve on jeans, etc.
 Special part set with edge guides
 for right- and left parts.

Pour le surpiquage de coutures
 de côtés sur l'arrondi de la
 hanche pour les jeans, etc., jeu
 de pièces spécial avec butées
 pour pièces de droite et de
 gauche.

Para sobrepuntear las costuras
 laterales en la zona de las caderas
 de vaqueros etc., juego de piezas
 especial con topos para oiezas
 izquierdas y derechas.

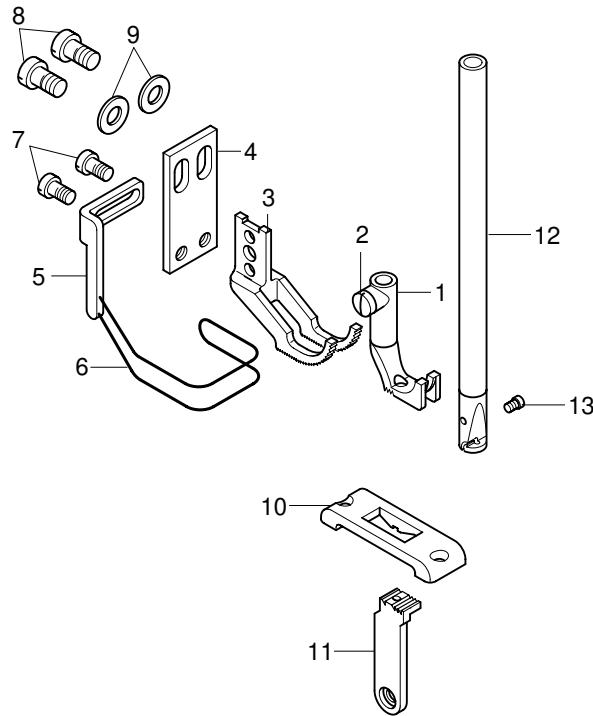

Pos.-Nr. Item No. N° pos. N° de pos.	Teil-Nr. Part No. N° de piezas N° de pieza	Pos.-Nr. Item No. N° pos. N° de pos.	Teil-Nr. Part No. N° de piezas N° de pieza
1 - 11	91-202 189-93/001	6	91-057 808-05 3
1 - 2	91-149 200-93/001	7	11-108 171-15
2	91-000 085-25	8	11-108 222-15
3	91-049 792-04/004	9	12-305 144-15
4 - 7	91-057 806-91	10	91-158 292-05
4	91-057 720-15	11	91-059 254-04/001
5 - 6	91-057 807-91	12 - 13	91-710 650-92
5	91-154 702-15	13	91-173 664-15

19.01

Nähwerkzeuge
Gauge parts
Organes de couture
Organos de costura PFAFF 1295

-17/01-940/01 CN♦

Arbeitsgang
Operation
Opération
Opéracion

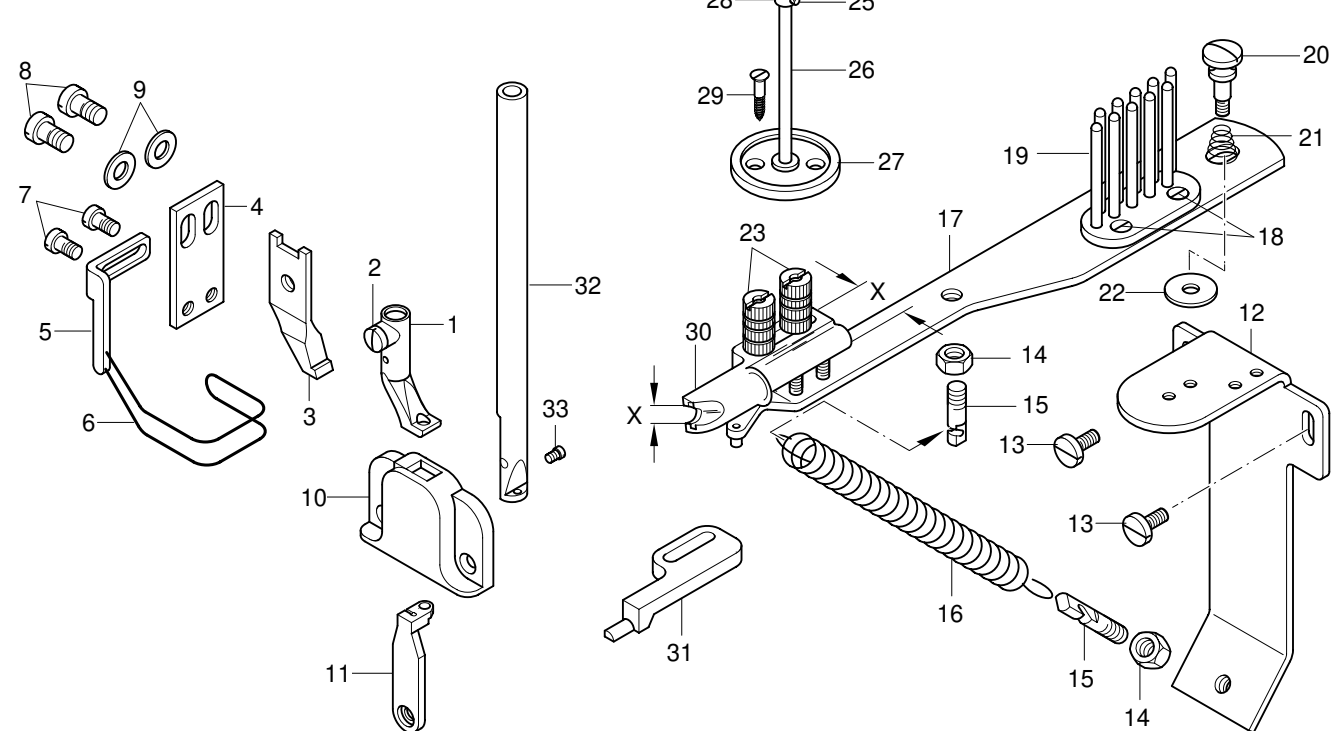
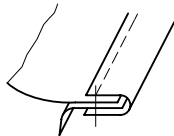

Pos.-Nr. Item No. N° pos. N° de pos.	Teile-Nr. Part No. N° de pièces N° de pieza
1 - 29	91-202 143-93/001
1 - 2	91-046 546-93/007
2	91-000 085-15
3	91-046 547-04/003
4 - 7	91-057 721-91
4	91-057 720-15
5 - 6	91-057 697-91
5	91-154 702-15
6	91-055 205-05 [3]
7	11-108 171-15
8	11-108 222-15
9	12-305 144-15
10	91-048 487-04/002
11	91-047 169-04/002
12 - 23	91-156 732-90/001
12	91-156 732-25
13	91-000 717-15
14	12-005 195-15
15	11-347 301-15

Pos.-Nr. Item No. N° pos. N° de pos.	Teile-Nr. Part No. N° de pièces N° de pieza
16	91-009 934-05
17	91-053 671-21
18	91-000 380-25
19	91-044 251-21
20	91-000 824-25
21	91-040 624-25
22	91-028 036-25
23	91-001 592-25
24 - 29	91-043 943-70/895
24	91-043 124-71/895
25	91-000 388-15
26	91-043 946-25
27	91-043 945-75/895
28	91-043 947-92
29	11-470 355-25
30	91-046 727-23 [5] [95/8]
31	91-056 384-05
32 - 33	91-712 488-92
33	91-173 664-15

-6/01 BN♦

Für allgemeine Näharbeiten.
 Standardform des Teilesatzes.

For ordinary sewing operations.
 Standard part set.

Travaux d'utilité courante.
 Jeu de pièces standard.

Para trabajos de costura en general.
 Juego de piezas estándar.

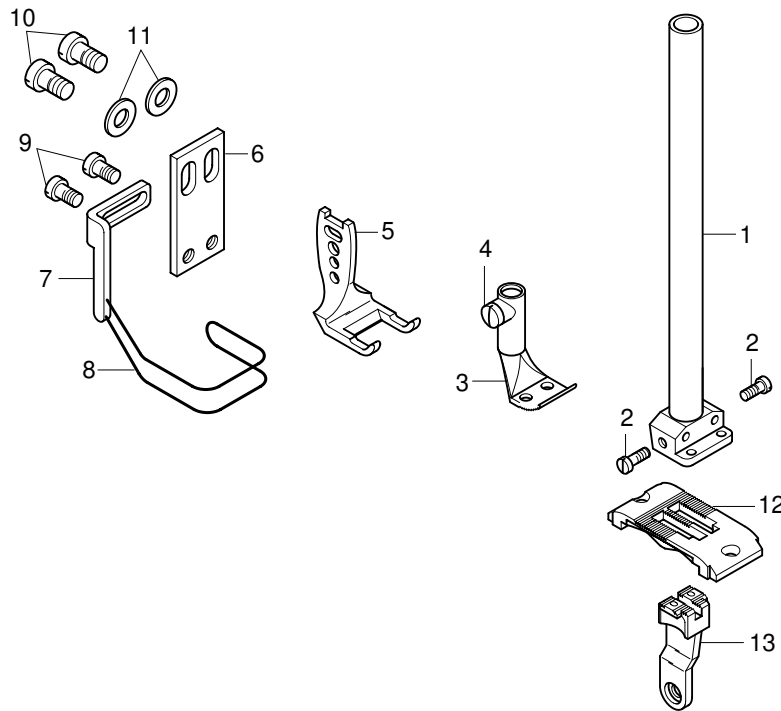

Pos.-Nr. Item No. N° pos. N° de pos.	Nadelabstand Needle gauge Ecartement de aiguilles Dist. entre aguja	Teile-Nr. Part No. N° de piezas N° de pieza
1 - 13	8,0 12,0	91-202 138-93/007 91-202 138-93/004
1 - 2	8,0 12,0	91-710 749-93/012 91-710 749-93/017
2		91-173 664-15
3 - 4	8,0 12,0	91-049 267-93/040 91-049 267-93/043
4		91-000 085-25
5	8,0 12,0	91-040 429-04/008 91-040 429-04/012
6 - 9		91-057 806-91
6		91-057 720-15

Pos.-Nr. Item No. N° pos. N° de pos.	Nadelabstand Needle gauge Ecartement de aiguilles Dist. entre aguja	Teile-Nr. Part No. N° de piezas N° de pieza
7 - 8		91-057 807-91
7		91-154 702-15
8		91-057 808-05
9		11-108 171-15
10		11-108 222-15
11		12-305 144-15
12	8,0 12,0	91-158 551-04/010 91-158 551-04/018
13	8,0 12,0	91-040 447-04/023 91-040 447-04/031

-6/01 CN♦

Für allgemeine Näharbeiten.
 Standardform des Teilesatzes.

For ordinary sewing operations.
 Standard part set.

Travaux d'utilité courante.
 Jeu de pièces standard.

Para trabajos de costura en general.
 Juego de piezas estándar.

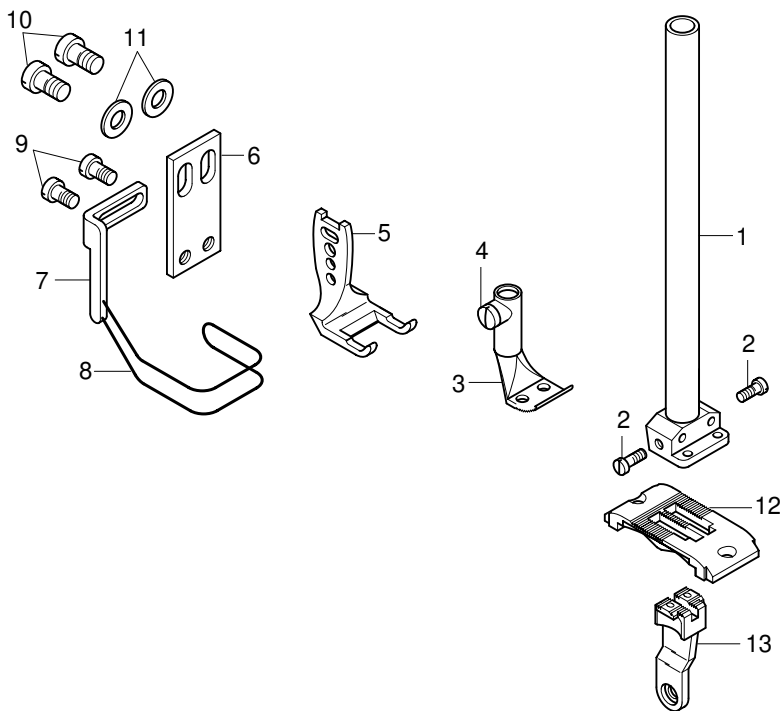

Pos.-Nr. Item No. N° pos. N° de pos.	Nadelabstand Needle gauge Ecartement de aiguilles Dist. entre aguja	Teile-Nr. Part No. N° de piezas N° de pieza	Pos.-Nr. Item No. N° pos. N° de pos.	Nadelabstand Needle gauge Ecartement de aiguilles Dist. entre aguja	Teile-Nr. Part No. N° de piezas N° de pieza
1 -	3,2 6,0 6,4 7,2 8,0 10,0 12,0 16,0 19,2	91-202 138-93/003 91-202 138-93/001 91-202 138-93/005 91-202 138-93/010 91-202 138-93/006 91-202 138-93/002 91-202 138-93/008 91-202 138-93/009 91-202 138-93/011	6		91-057 720-15
1 - 2	3,2 6,0 6,4 7,2 8,0 10,0 12,0 16,0 19,2	91-710 749-93/003 91-710 749-93/009 91-710 749-93/010 91-710 749-93/011 91-710 749-93/012 91-710 749-93/015 91-710 749-93/017 91-710 749-93/021 91-710 749-93/024	7 - 8	3,2 6,0; 6,4; 7,2; 8,0; 10,0; 12,0 16,0; 19,2	91-057 742-91 91-057 807-91 91-057 810-91
2		91-173 664-15	7	3,2; 6,0; 6,4; 7,2; 8,0; 10,0; 12,0; 16,0; 19,2	91-055 201-15
3 - 4	3,2 6,0 6,4 7,2 8,0 10,0 12,0 16,0 19,2	91-049 267-93/002 91-049 267-93/005 91-049 267-93/006 91-049 267-93/007 91-049 267-93/008 91-049 267-93/010 91-049 267-93/011 91-049 267-93/013 91-049 267-93/031	8	3,2 6,0; 6,4; 7,2; 8,0; 10,0; 12,0; 16,0; 19,2	91-057 743-05 3 91-057 808-05 3 91-057 811-05 3
4		91-000 085-25	9		11-108 171-15
5	3,2 6,0; 6,4 7,2; 8,0 10,0 12,0 16,0 19,2	91-040 429-04/041 91-040 429-04/007 91-040 429-04/008 91-040 429-04/010 91-040 429-04/012 91-040 429-04/015 91-040 429-04/018	10		11-108 222-15
6 - 9	3,2 6,0; 6,4; 7,2; 8,0; 10,0; 12,0 16,0; 19,2	91-057 741-91 91-057 806-91 91-057 809-91	11		12-305 144-15
			12	3,2 6,0 6,4 7,2 8,0 10,0 12,0 16,0 19,2	91-058 406-04/009 91-158 551-04/007 91-158 551-04/008 91-158 551-04/009 91-158 551-04/011 91-158 551-04/015 91-158 551-04/019 91-158 551-04/025 91-158 551-04/038
			13	3,2 6,0 6,4 7,2 8,0 10,0 12,0 16,0 19,2	91-047 814-04/009 91-040 447-04/056 91-040 447-04/051 91-040 447-04/053 91-040 447-04/054 91-040 447-04/057 91-040 447-04/059 91-040 447-04/078 91-040 447-04/090

-6/01-900/56 CN♦

Für allgemeine Näharbeiten.
 Standardform des Teilesatzes.

For ordinary sewing operations.
 Standard part set.

Travaux d'utilité courante.
 Jeu de pièces standard.

Para trabajos de costura en general.
 Juego de piezas estándar.

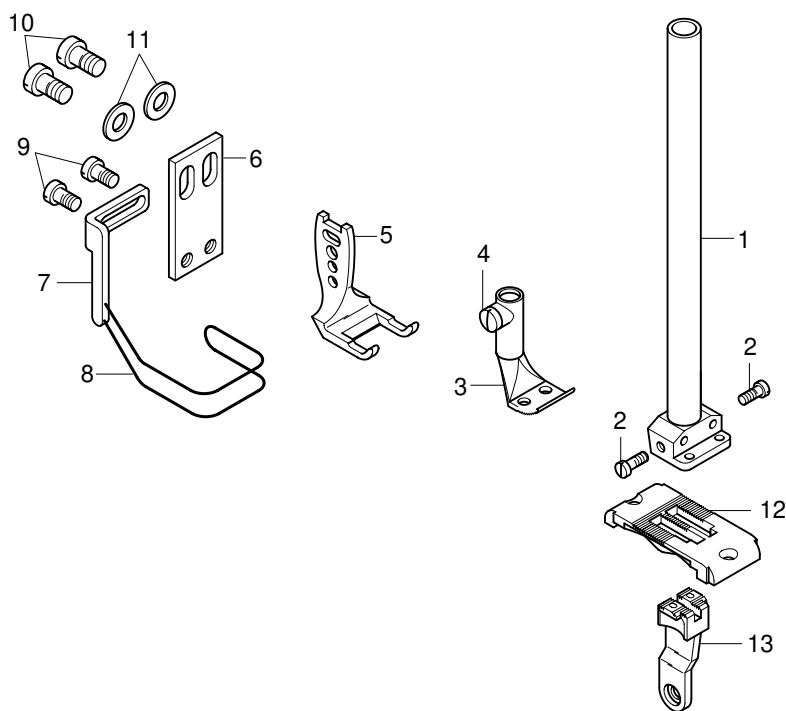

Pos.-Nr. Item No. N° pos. N° de pos.	Nadelabstand Needle gauge Ecartement de aiguilles Dist. entre aguja	Teile-Nr. Part No. N° de piezas N° de pieza	Pos.-Nr. Item No. N° pos. N° de pos.	Nadelabstand Needle gauge Ecartement de aiguilles Dist. entre aguja	Teile-Nr. Part No. N° de piezas N° de pieza
1 -	3,2 4,8 6,0 6,4 8,0 10,0 11,2 12,0	91-202 139-93/002 91-202 139-93/007 91-202 139-93/006 91-202 139-93/003 91-202 139-93/004 91-202 139-93/005 91-202 139-93/009 91-202 139-93/001	6		91-057 720-15
1 - 2	3,2 4,8 6,0 6,4 8,0 10,0 11,2 12,0	91-710 749-93/003 91-710 749-93/006 91-710 749-93/009 91-710 749-93/010 91-710 749-93/012 91-710 749-93/015 91-710 749-93/016 91-710 749-93/017	7 - 8	3,2 4,8; 6,0; 6,4; 8,0; 10,0; 11,2; 12,0	91-057 742-91 91-057 807-91
2		91-173 664-15	7	3,2; 4,8; 6,0; 6,4; 8,0; 10,0; 11,2; 12,0;	91-154 702-15
3 - 4	3,2 4,8 6,0 6,4 8,0 10,0 11,2 12,0	91-049 267-93/002 91-049 267-93/004 91-049 267-93/005 91-049 267-93/006 91-049 267-93/008 91-049 267-93/010 91-049 267-93/032 91-049 267-93/011	8	3,2 4,8; 6,0; 6,4; 8,0; 10,0; 11,2; 12,0	91-057 743-05 3 91-057 808-05 3
4		91-000 085-25	9		11-108 171-15
5	3,2 4,8 6,0; 6,4 8,0 10,0 11,2 12,0	91-040 429-04/041 91-040 429-04/006 91-040 429-04/007 91-040 429-04/008 91-040 429-04/010 91-040 429-04/011 91-040 429-04/012	10		11-108 222-15
6 - 9	3,2 4,8; 6,0; 6,4; 8,0; 10,0; 11,2; 12,0	91-057 741-91 91-057 806-91	11		12-305 144-15
			12	3,2 4,8 6,0 6,4 8,0 10,0 11,2 12,0	91-158 056-04/003 91-158 056-04/005 91-158 056-04/007 91-158 056-04/009 91-158 056-04/013 91-158 056-04/015 91-158 056-04/029 91-158 056-04/017
			13	3,2 4,8 6,0 6,4 8,0 10,0 11,2 12,0	91-059 175-04/003 91-059 175-04/005 91-059 175-04/007 91-059 175-04/009 91-059 175-04/013 91-059 175-04/015 91-059 175-04/029 91-059 175-04/017

19.02

Nähwerkzeuge
Gauge parts
Organes de couture
Organos de costura PFAFF 1296

-63/14 CN♦

Arbeitsgang
Operation
Opération
Opéracion

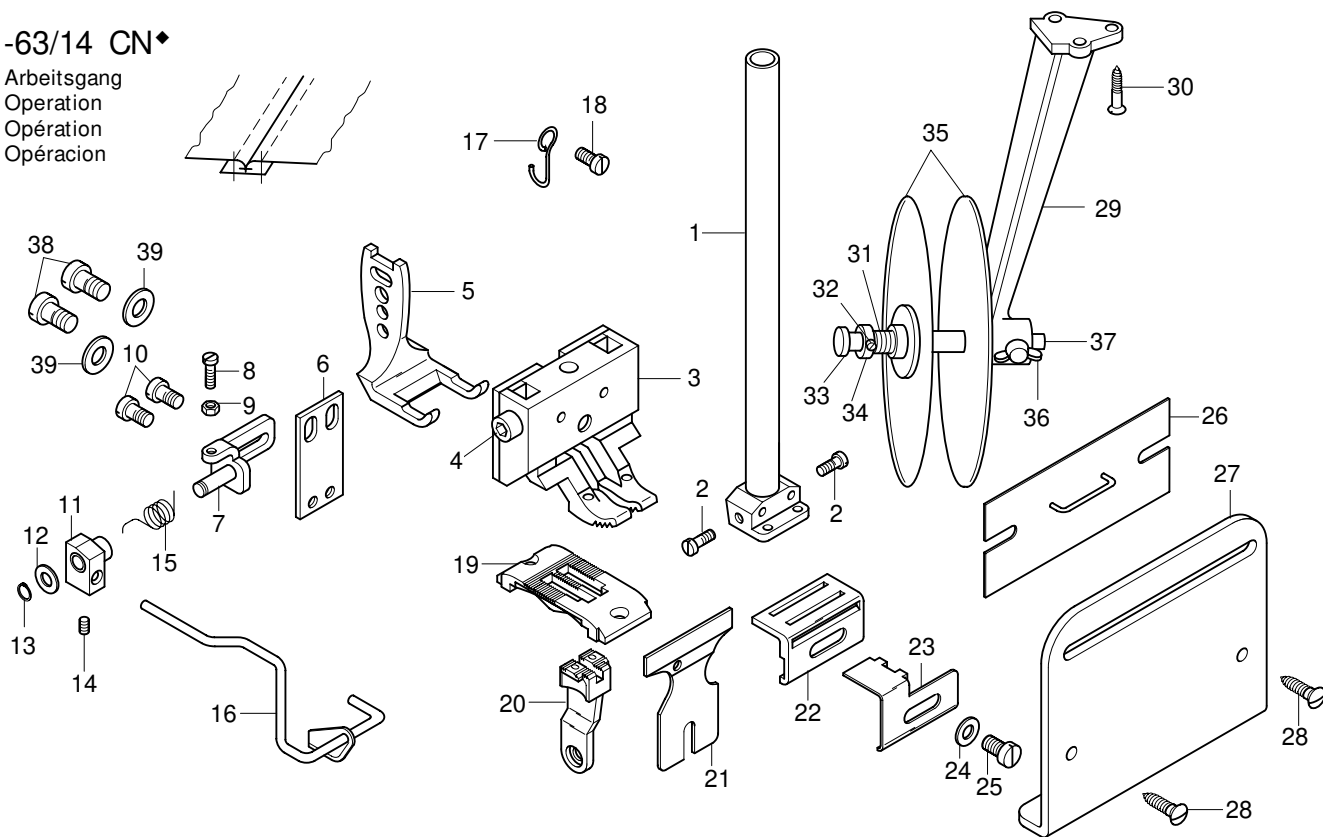

Pos.-Nr. Item No. N° pos. N° de pos.	Nadelabstand Needle gauge Ecartement de aiguilles Dist. entre aguja	Teile-Nr. Part No. N° de piezas N° de pieza
1 - 26	8,0	91-202 140-93/001
1 - 2	8,0	91-710 749-93/012
2		91-173 664-15
3 - 4	8,0	91-149 152-93/003
4		11-130 185-15
5	8,0	91-049 998-04/001
6 - 16		91-156 614-91
6		91-057 720-15
7		91-156 597-91
8		11-108 099-15
9		12-024 121-25
10		11-130 167-15
11		91-156 605-05
12		12-360 033-05
13		12-610 170-45
14		11-330 085-15
15		91-156 606-05
16		91-156 602-11
17		91-149 112-05
18		11-108 174-15
19	8,0	91-158 551-04/011
20	8,0	91-040 447-04/054

Pos.-Nr. Item No. N° pos. N° de pos.	Nadelabstand Needle gauge Ecartement de aiguilles Dist. entre aguja	Teile-Nr. Part No. N° de piezas N° de pieza
21 - 25		91-041 182-91
21		91-053 069-25
22		91-053 070-21
23		91-053 073-25
24		12-315 110-15
25		91-000 089-25
26		91-042 211-21
27		91-044 419-25
28		11-470 109-25
29 - 37		91-041 644-70/895
29		91-026 558-75/895
30		11-470 355-15
31		91-025 694-05
32		91-000 388-15
33		91-043 143-25
34		91-043 191-92
35		91-043 138-71/895
36		11-505 292-25
37		91-043 148-21
38		11-108 222-15
39		12-305 144-15

-63/14-900/56 CN♦

Arbeitsgang
Operation
Opération
Operación

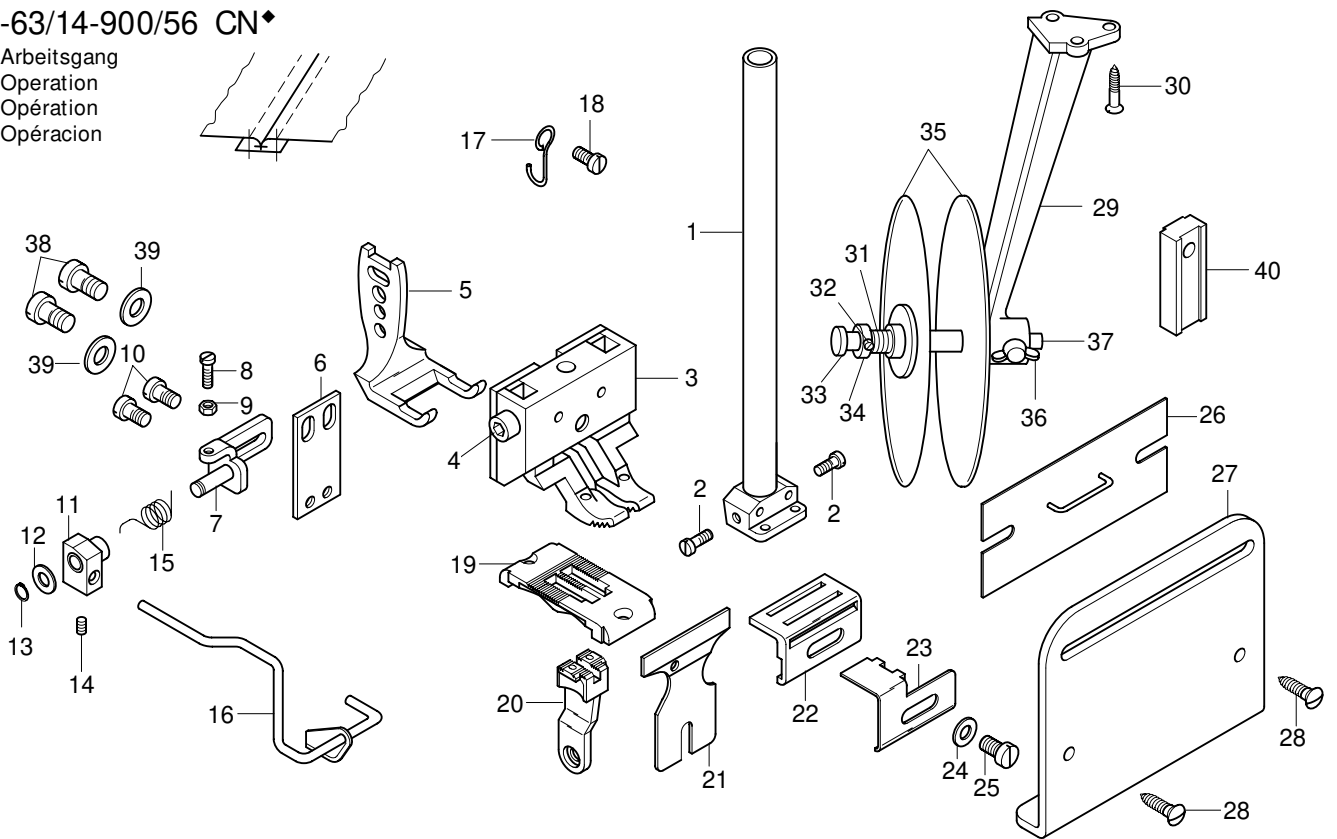

Pos.-Nr. Item No. N° pos.	Nadelabstand Needle gauge Ecartement de aiguilles Dist. entre aguja	Teile-Nr. Part No. N° de piezas N° de pieza
1 - 26	8,0 10,0	91-202 141-93/001 91-202 141-93/002
1 - 2	8,0 10,0	91-710 749-93/012 91-710 749-93/015
2		91-173 664-15
3 - 4	8,0 10,0	91-149 152-93/003 91-149 152-93/001
4		11-130 185-15
5	8,0 10,0	91-049 998-04/001 91-049 998-04/003
6 - 16		91-156 614-91
6		91-057 720-15
7		91-156 597-91
8		11-108 099-15
9		12-024 121-25
10		11-130 167-15
11		91-156 605-05
12		12-360 033-05
13		12-610 170-45
14		11-330 085-15
15		91-156 606-05
16		91-156 602-11
17		91-149 112-05
18		11-108 174-15

Pos.-Nr. Item No. N° pos.	Nadelabstand Needle gauge Ecartement de aiguilles Dist. entre aguja	Teile-Nr. Part No. N° de piezas N° de pieza
19	8,0 10,0	91-158 056-04/013 91-158 056-04/015
20	8,0 10,0	91-059 175-04/013 91-059 175-04/015
21 - 25		91-041 182-91
21		91-053 069-25
22		91-053 070-21
23		91-053 073-25
24		12-315 110-15
25		91-000 089-25
26		91-042 211-21
27		91-044 419-25
28		11-470 109-25
29 - 37		91-041 644-70/895
29		91-026 558-75/895
30		11-470 355-15
31		91-025 694-05
32		91-000 388-15
33		91-043 143-25
34		91-043 191-92
35		91-043 138-71/895
36		11-505 292-25
37		91-043 148-21
38		11-108 222-15
39		12-305 144-15
40		91-156 709-05

-63/15 CN♦

Arbeitsgang
Operation
Opération
Opéracion

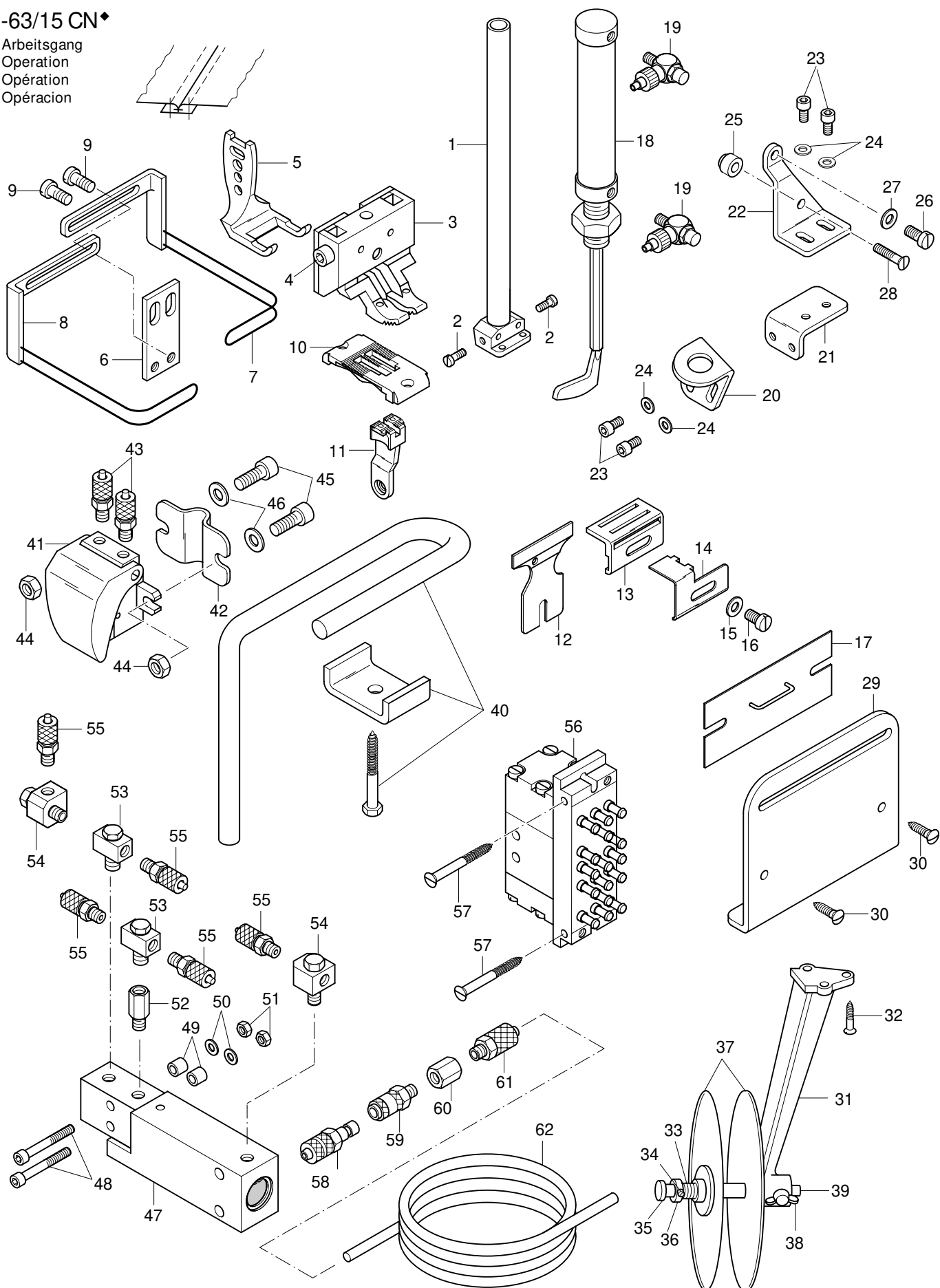

Pos.-Nr. Item No. N° pos. N° de pos.	Nadelabstand Needle gauge Ecartement de aiguilles Dist. entre aguja	Teile-Nr. Part No. N° de pièces N° de pieza
1 - 28	8,0 10,0	91-202 298-93/001 91-202 298-93/002
1 - 2	8,0 10,0	91-710 749-93/012 91-710 749-93/015
2		91-173 664-15
3 - 4	8,0 10,0	91-149 152-93/003 91-149 152-93/001
4		11-130 185-15
5	8,0 10,0	91-049 998-04/001 91-049 998-04/003
6 - 9		91-154 776-91
6		91-057 720-15
7		91-154 915-91
8		91-154 712-91
9		11-108 174-15
10	8,0 10,0	91-158 551-04/011 91-158 551-04/015
11	8,0 10,0	91-040 447-04/054 91-040 447-04/057
12 - 16		91-041 182-91
12		91-053 069-25
13		91-053 070-21
14		91-053 073-25
15		12-315 110-15
16		91-000 089-25
17		91-042 211-21
18 - 28		91-156 731-91
18		99-137 180-91
19		99-135 233-91
20 - 24		91-156 730-21
20		91-156 713-25
21		91-156 712-25
22		91-156 728-25
23		11-130 170-25
24		12-305 114-25
25		91-156 729-25
26		11-108 222-15
27		12-305 144-15
28		11-210 178-25

Pos.-Nr. Item No. N° pos. N° de pos.	Nadelabstand Needle gauge Ecartement de aiguilles Dist. entre aguja	Teile-Nr. Part No. N° de pièces N° de pieza
29		91-044 419-25
30		11-470 109-25
31 - 39		91-041 644-70/895
31		91-026 558-75/895
32		11-470 355-15
33		91-025 694-05
34		91-000 388-15
35		91-043 143-25
36		91-043 191-92
37		91-043 138-71/895
38		11-505 292-25
39		91-043 148-21
40 - 55		91-265 109-90
40		99-136 964-91
41		99-136 963-91
42		91-265 072-05
43		99-115 425-91
44		12-024 191-25
45		11-130 293-25
46		12-305 174-25
47 - 55		91-271 027-91
47		99-134 580-91
48		11-130 203-15
49		91-087 293-15
50		12-305 114-15
51		12-024 151-15
52		99-134 207-05
53		99-133 920-91
54		99-133 753-91
55		99-115 425-91
56		99-135 016-91
57		11-460 211-15
58		99-134 256-91
59		99-134 255-91
60		99-134 206-05
61		99-135 911-91
62		25-308 820-30 96

-63/15-900/56 CN♦

Arbeitsgang
 Operation
 Opération
 Opéracion

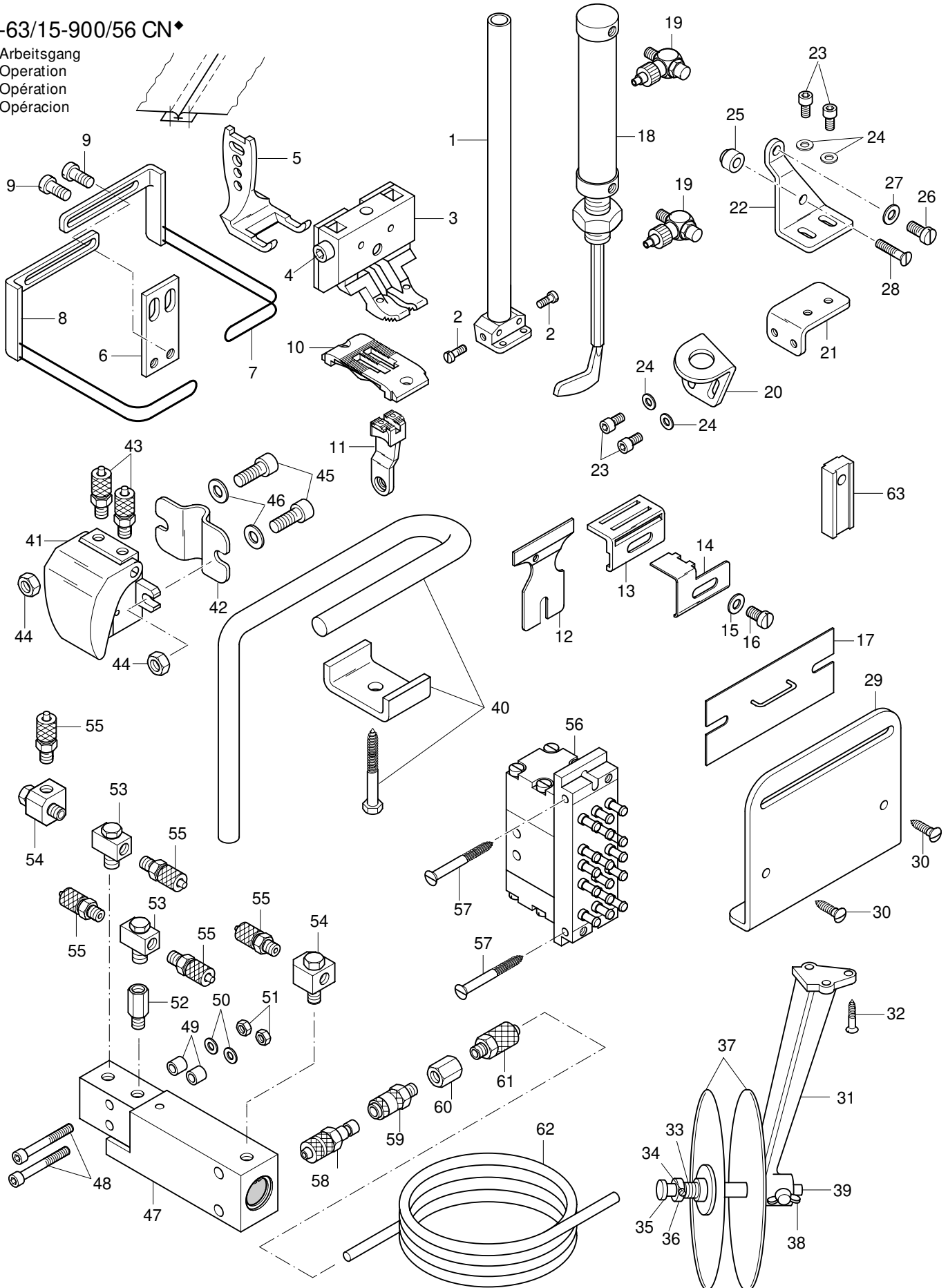

Pos.-Nr. Item No. N° pos. N° de pos.	Nadelabstand Needle gauge Ecartement de aiguilles Dist. entre aguja	Teile-Nr. Part No. N° de piezas N° de pieza
1 - 28	8,0 6,0 10,0	91-202 297-93/002 91-202 297-93/003 91-202 297-93/001
1 - 2	8,0 6,0 10,0	91-710 749-93/012 91-710 749-93/009 91-710 749-93/015
2		91-173 664-15
3 - 4	8,0 6,0 10,0	91-149 152-93/003 91-149 152-93/008 91-149 152-93/001
4		11-130 185-15
5	6,0; 8,0 10,0	91-049 998-04/001 91-049 998-04/003
6 - 9		91-154 776-91
6		91-057 720-15
7		91-154 915-91
8		91-154 712-91
9		11-108 174-15
10	8,0 6,0 10,0	91-158 056-04/013 91-158 056-04/007 91-158 056-04/015
11	8,0 6,0 10,0	91-059 175-04/013 91-059 175-04/007 91-059 175-04/015
12 - 16		91-041 182-91
12		91-053 069-25
13		91-053 070-21
14		91-053 073-25
15		12-315 110-15
16		91-000 089-25
17		91-042 211-21
18 - 28		91-156 731-91
18		99-137 180-91
19		99-135 233-91
20 - 24		91-156 730-21
20		91-156 713-25
21		91-156 712-25
22		91-156 728-25
23		11-130 170-25
24		12-305 114-25
25		91-156 729-25
26		11-108 222-15

Pos.-Nr. Item No. N° pos. N° de pos.	Nadelabstand Needle gauge Ecartement de aiguilles Dist. entre aguja	Teile-Nr. Part No. N° de piezas N° de pieza
27		12-305 144-15
28		11-210 178-25
29		91-044 419-25
30		11-470 109-25
31 - 39		91-041 644-70/895
31		91-026 558-75/895
32		11-470 355-15
33		91-025 694-05
34		91-000 388-15
35		91-043 143-25
36		91-043 191-92
37		91-043 138-71/895
38		11-505 292-25
39		91-043 148-21
40 - 55		91-265 109-90
40		99-136 964-91
41		99-136 963-91
42		91-265 072-05
43		99-115 425-91
44		12-024 191-25
45		11-130 293-25
46		12-305 174-25
47 - 55		91-271 027-91
47		99-134 580-91
48		11-130 203-15
49		91-087 293-15
50		12-305 114-15
51		12-024 151-15
52		99-134 207-05
53		99-133 920-91
54		99-133 753-91
55		99-115 425-91
56		99-135 016-91
57		11-460 211-15
58		99-134 256-91
59		99-134 255-91
60		99-134 206-05
61		99-135 911-91
62		25-308 820-30 96
63		91-156 709-05