

MX3200・5200

MX3200 Series 安全縫いミシン
Safety stitch machines

MX5200 Series オーバーロックミシン
Overedgers

Parts Checker

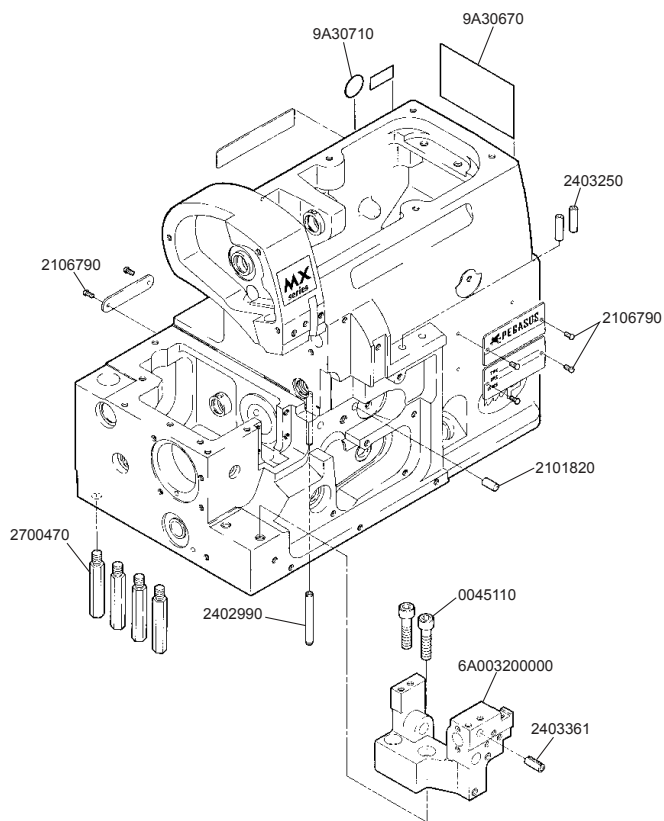
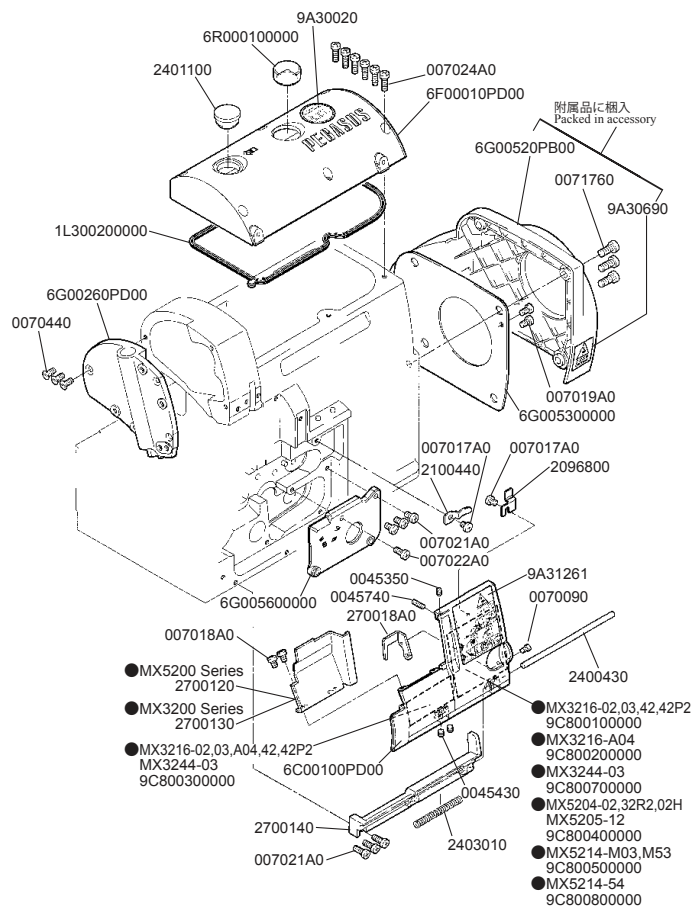
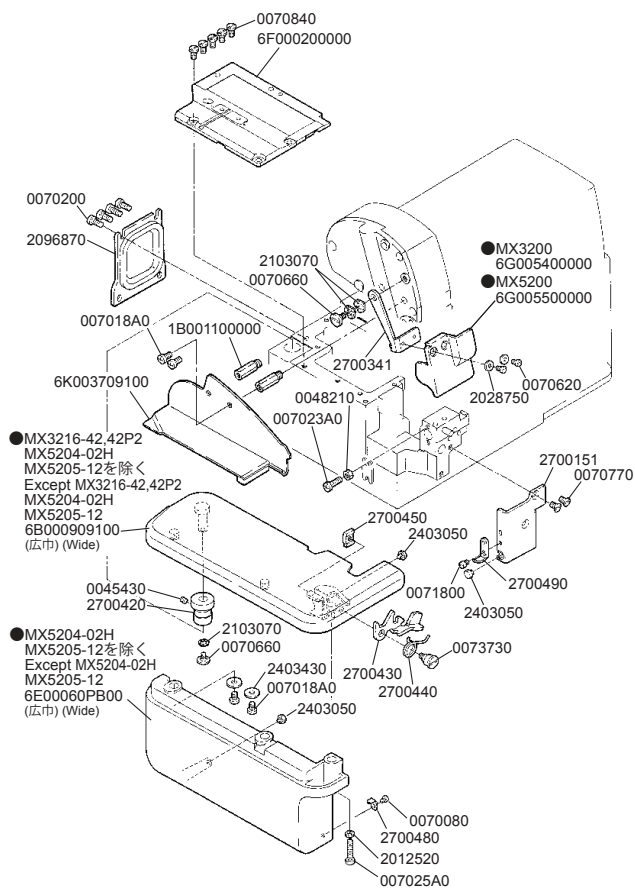
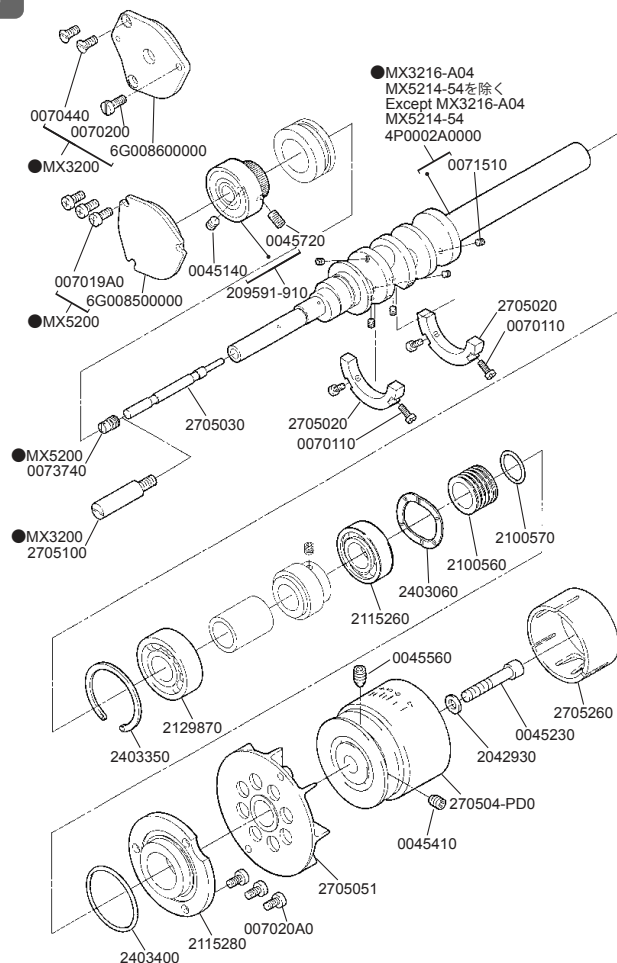

PEGASUS®

1**2****3****4**

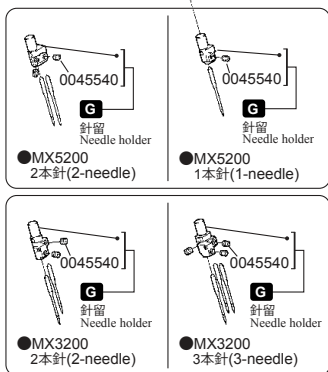
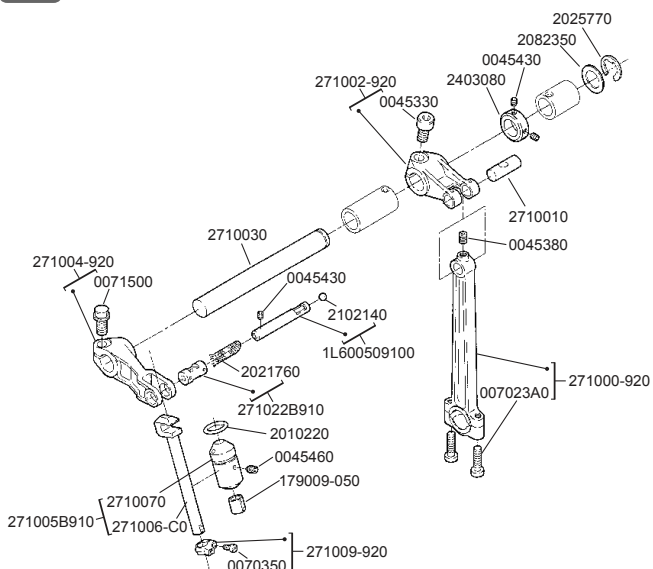

●MX3200

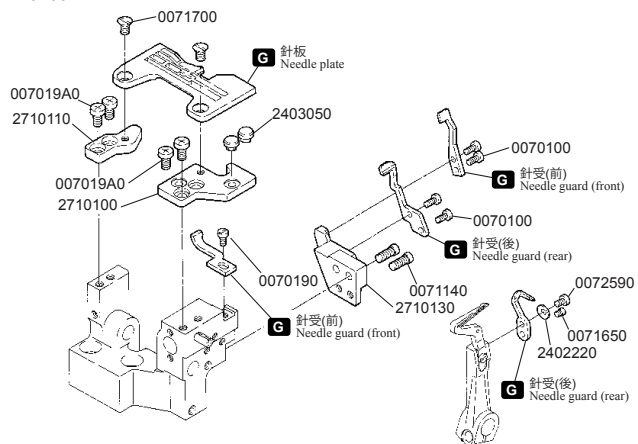

●MX5200

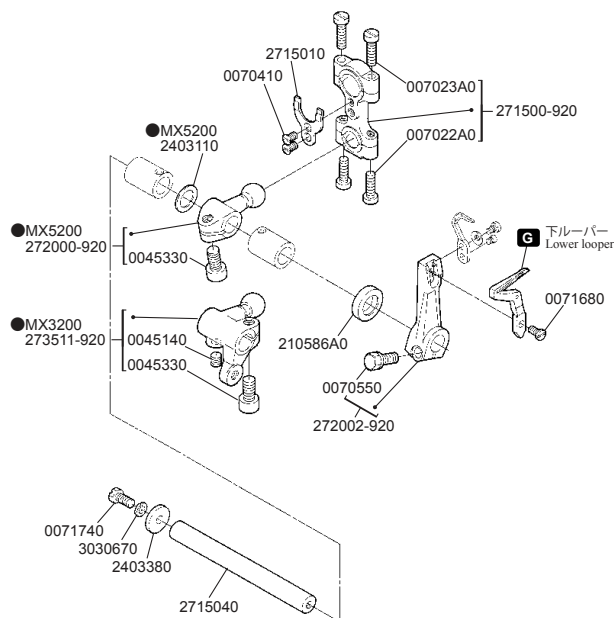
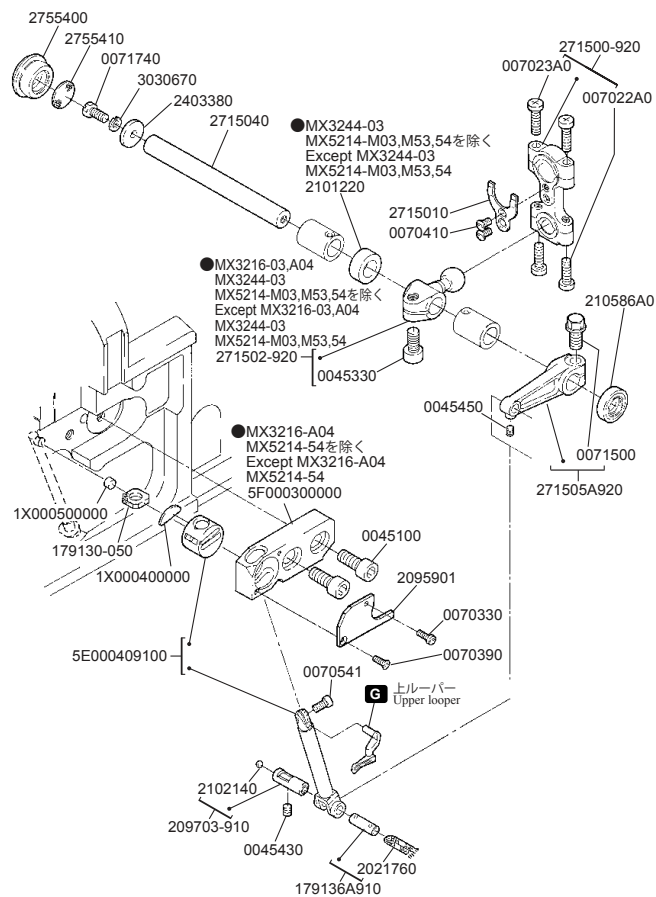
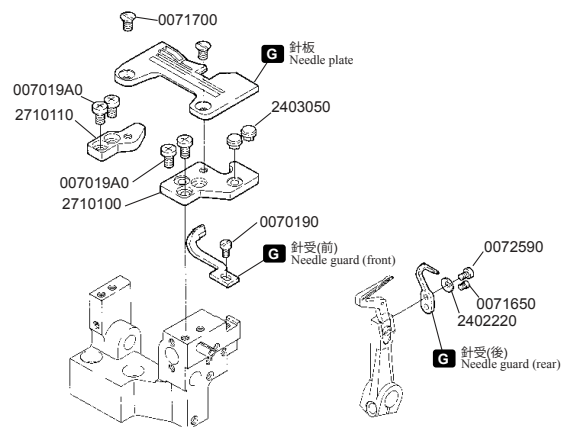

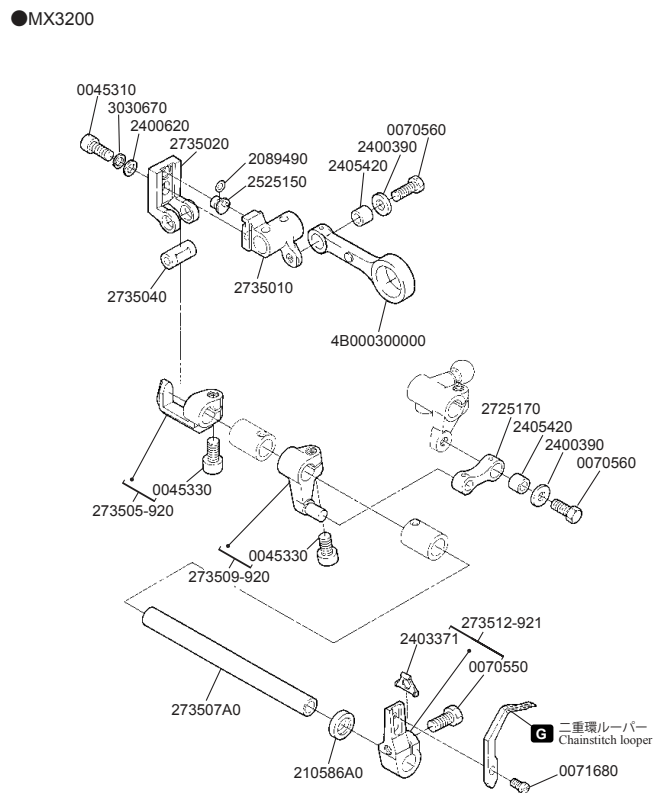
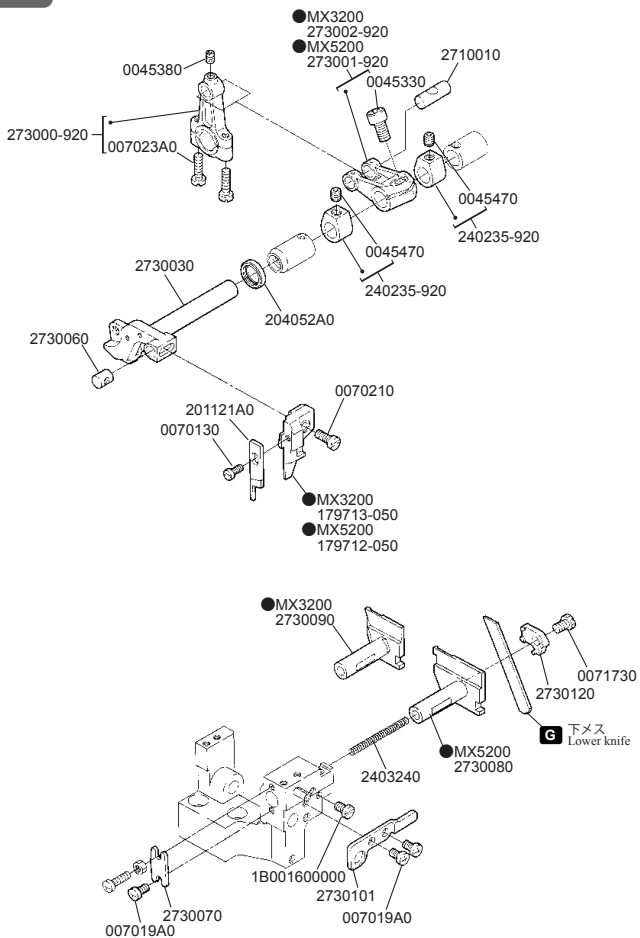
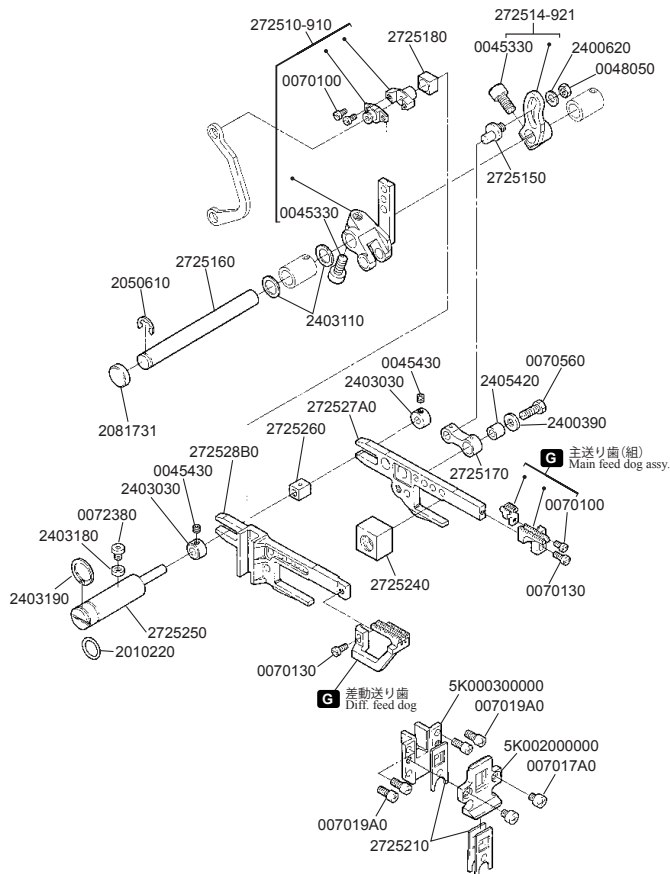
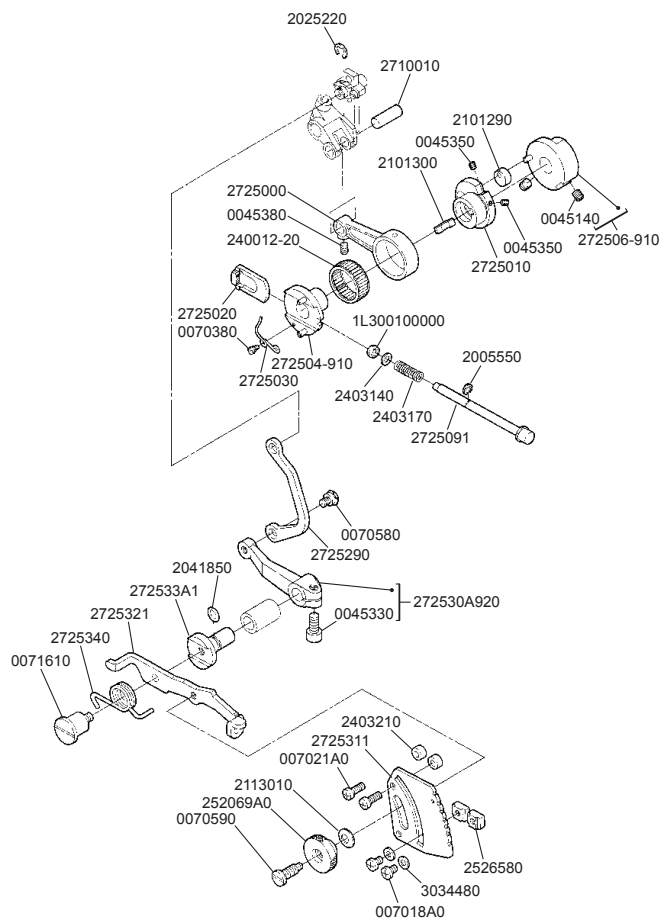

13

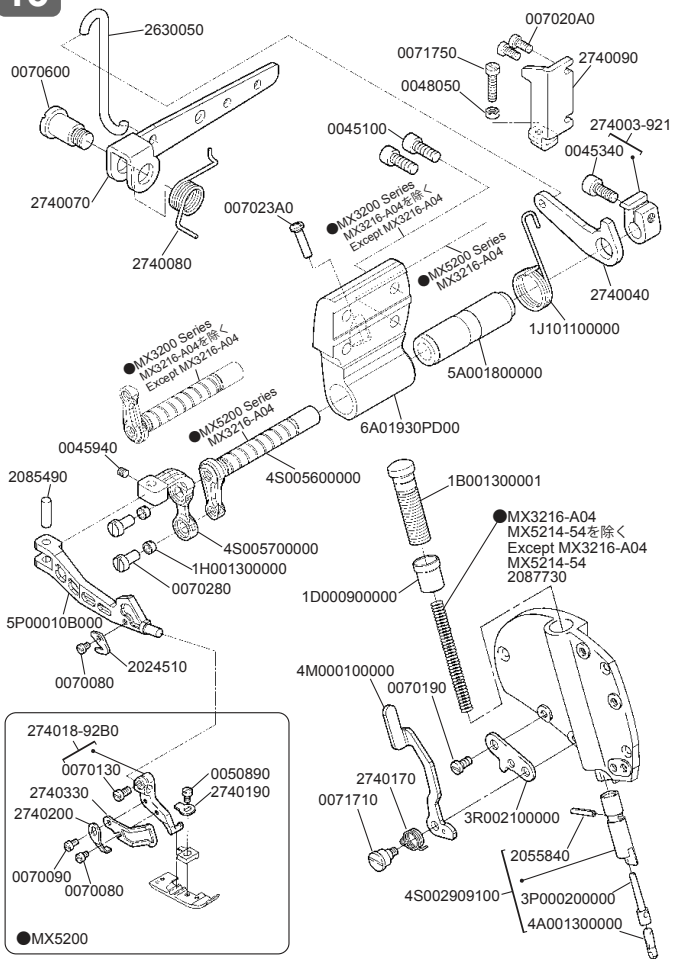

14

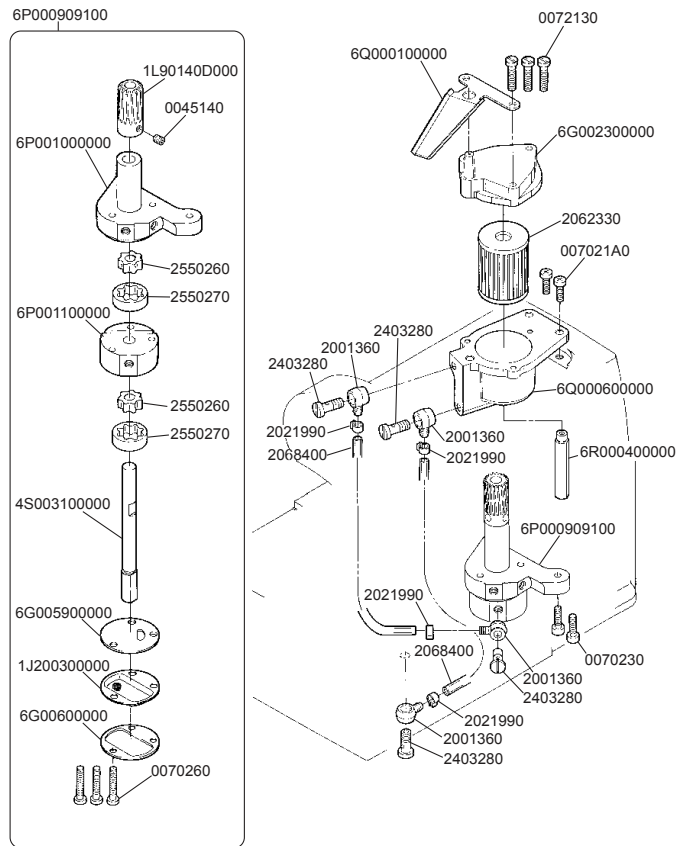

15

★印はインチネジです。
★=inchi size

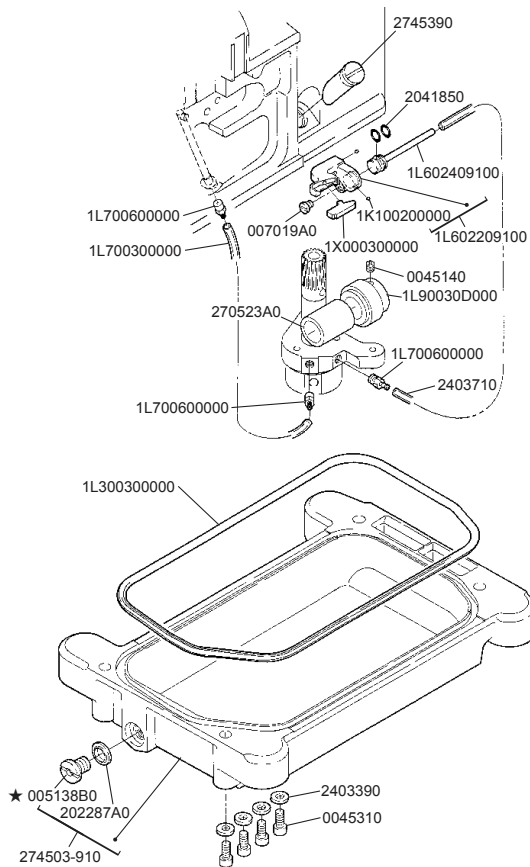

16

★印はインチネジです。
★=inchi size

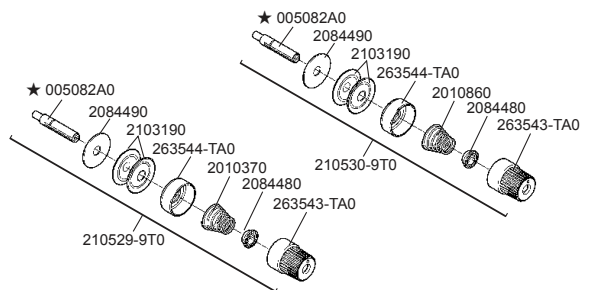

●MX5204-02.02H,32R2
MX5205-12
1本針(1-needle)

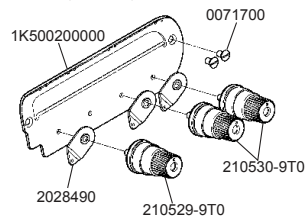

●MX3216-02.03.42.42P2
MX5214-M03,M53,54
2本針(2-needle)

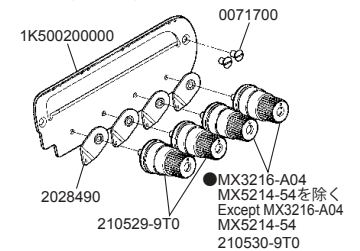

●MX3244-03
3本針(3-needle)

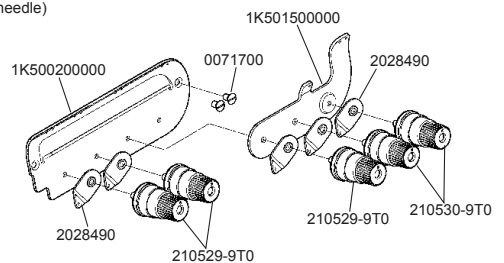

17

●MX3200

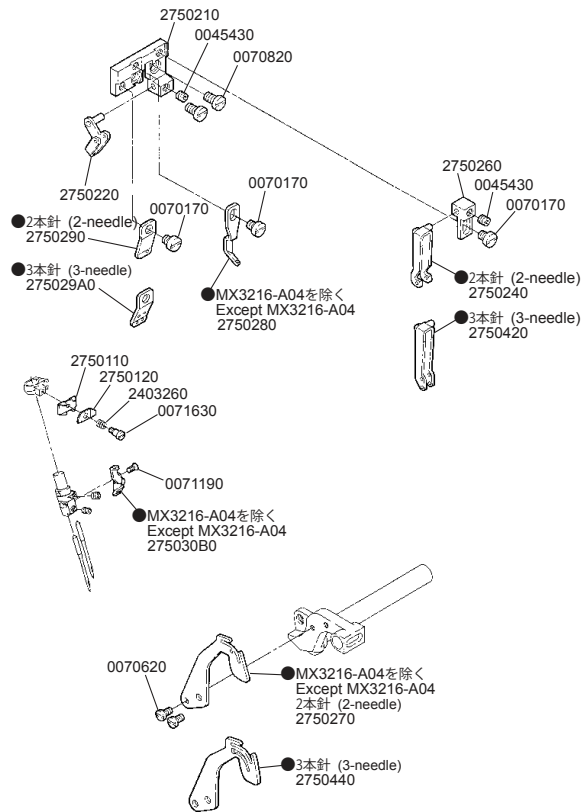

18

●MX5200

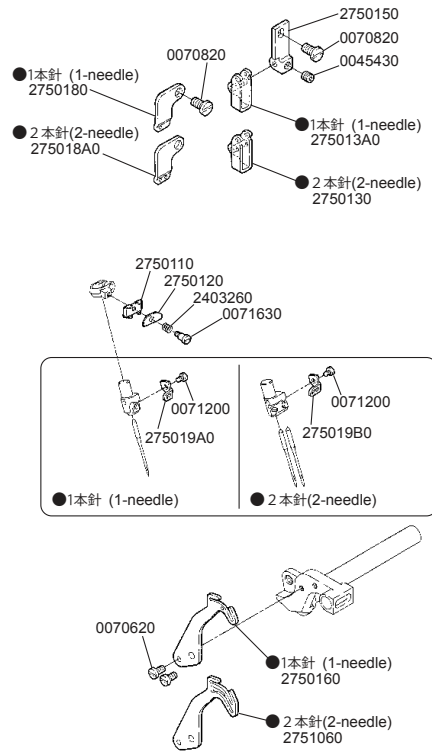

19

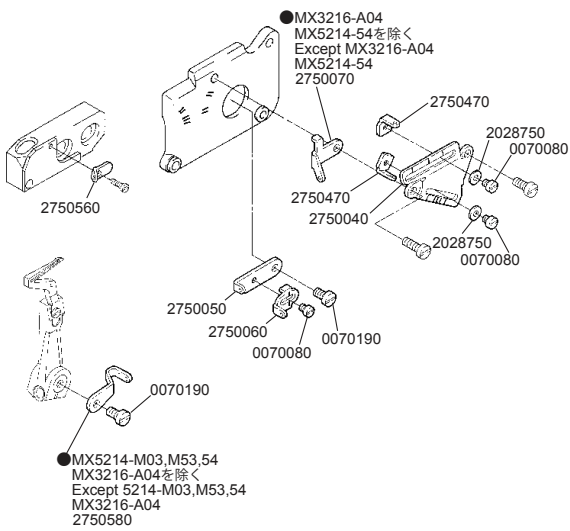

20

●MX3200

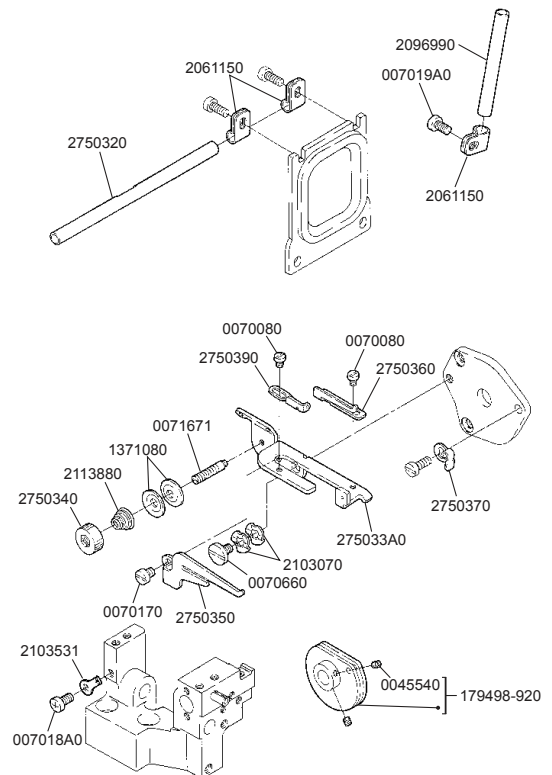

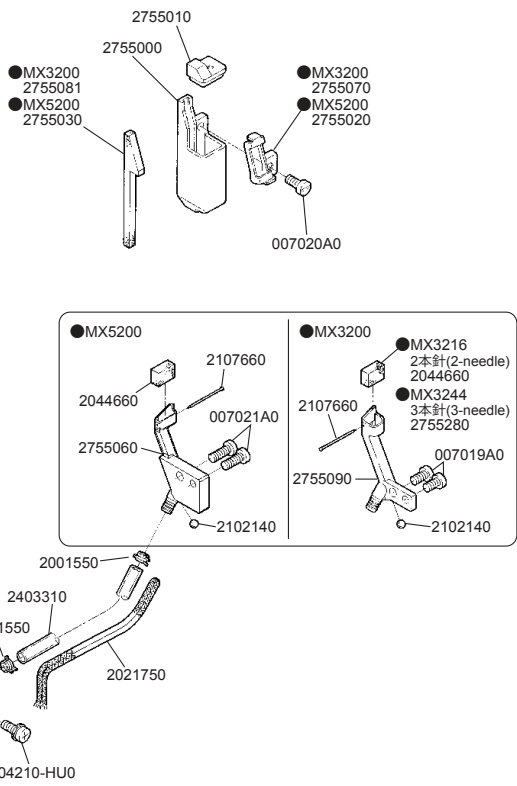

※印は非売品です。
※=Not for sale.

- 3本立(3-spool) 9E0012C9P00
- 4本立(4-spool) 9E0012B9P00
- 5本立(5-spool) 9E0012A9P00
- 6本立(6-spool) 9E001209P00

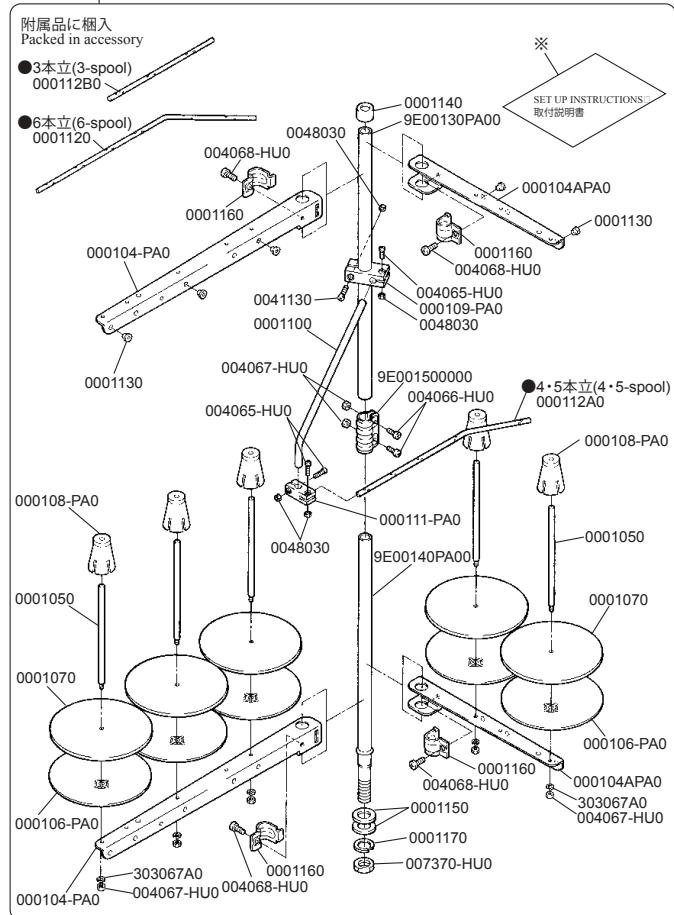

※印は非売品です。
※=Not for sale.

付属品に梱入
Packed in accessory

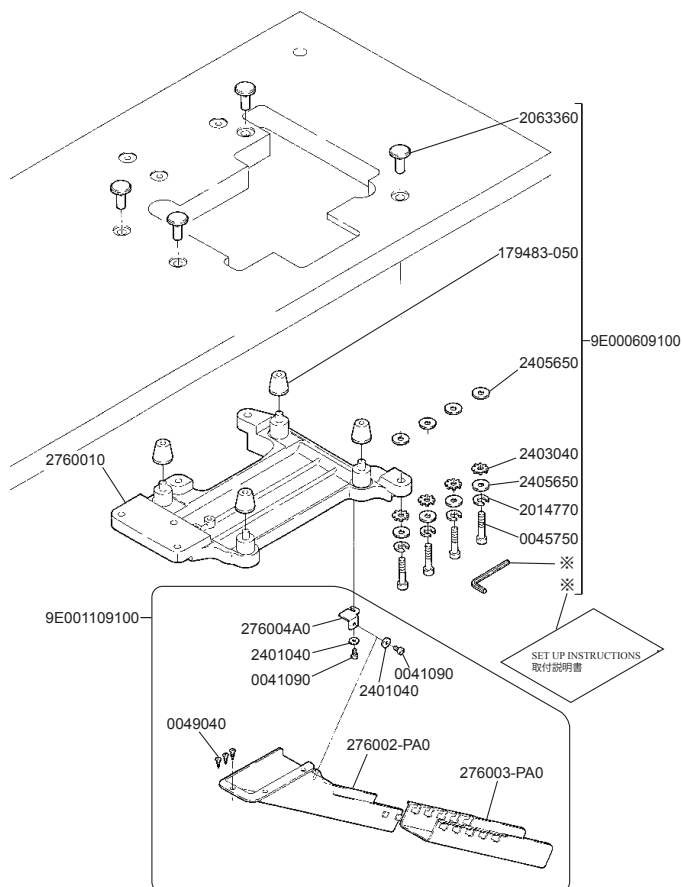

★印はインチネジです。
★=inchi size

G ゲージパーツ表参照
Refer to the gauge parts list.

●MX3216-02,03

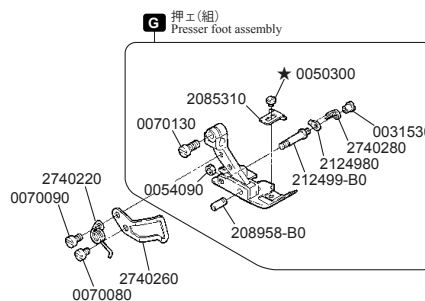

●MX3216-03

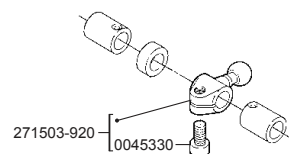

●MX3244-03

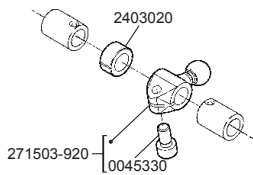
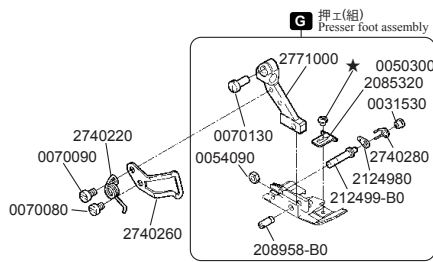

●MX3216-A04
ジーンズ用(for jeans)

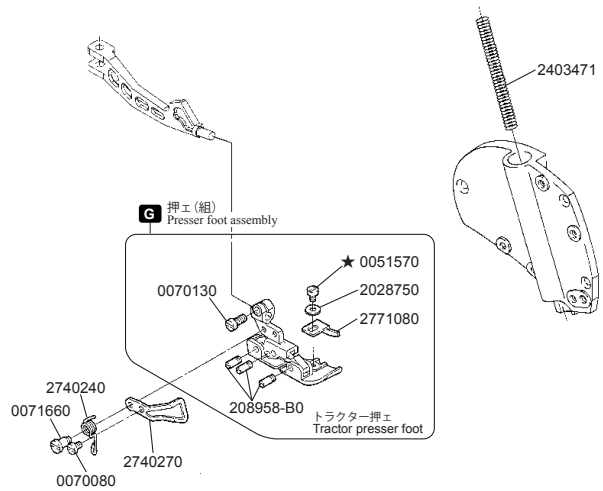
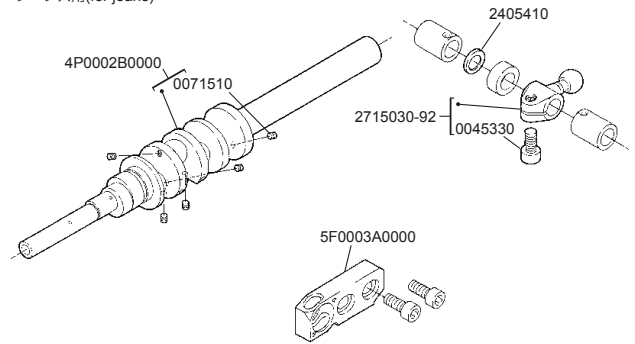

●MX3216-A04
ジーンズ用(for jeans)

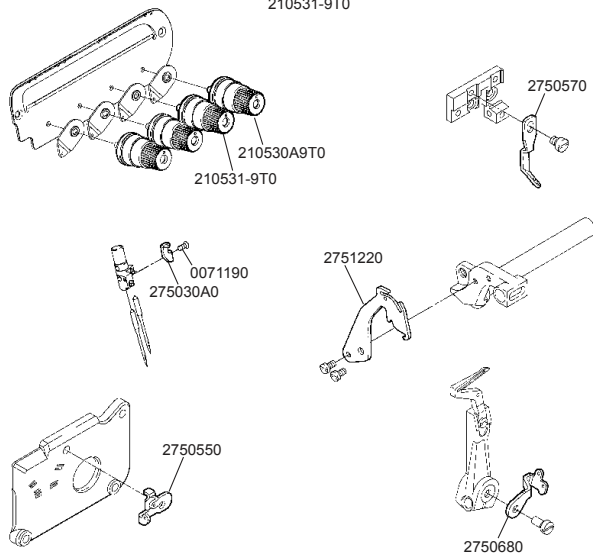
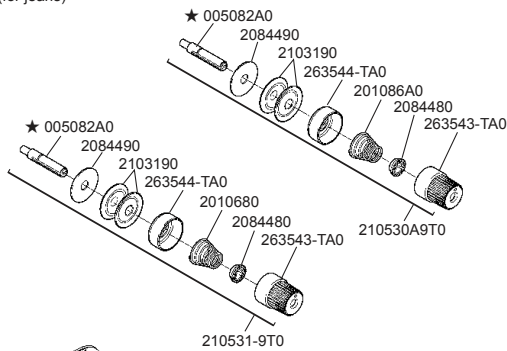

●MX3216-42,42P2

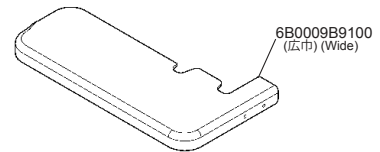

●MX3216-42
ヒタ取り(Shirring)

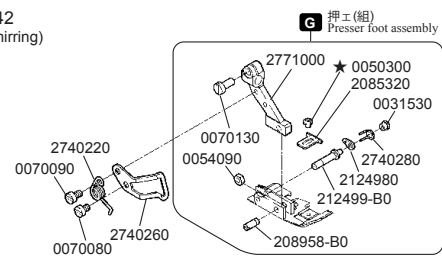

●MX3216-42P2
ヒタ取り・パイピング用
(Shirring & Piping)

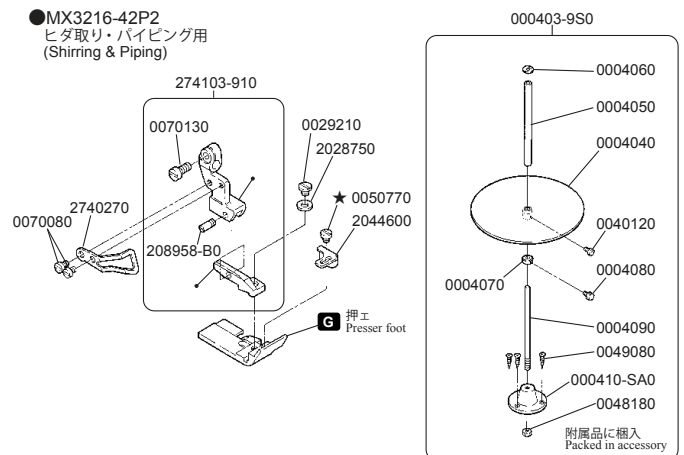

29

●MX3216-42,42P2
ヒタ取り(Shirring)

★印はインチネジです。
★=inchi size

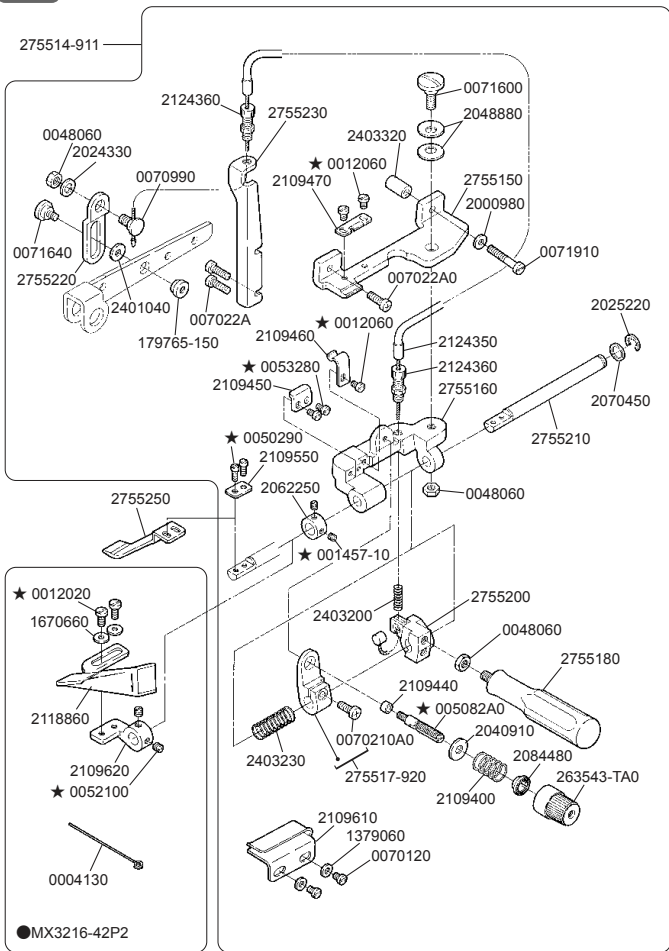

●MX3216-42P2

30

●MX5204-02H
裾引き(Blindhemming)

★印はインチネジです。 ★=inchi size **G** ゲージパーツ表参照 Refer to the gauge parts list.

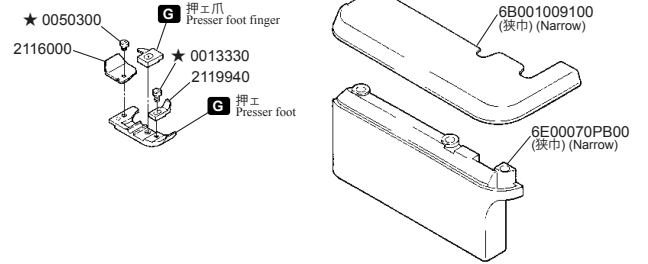
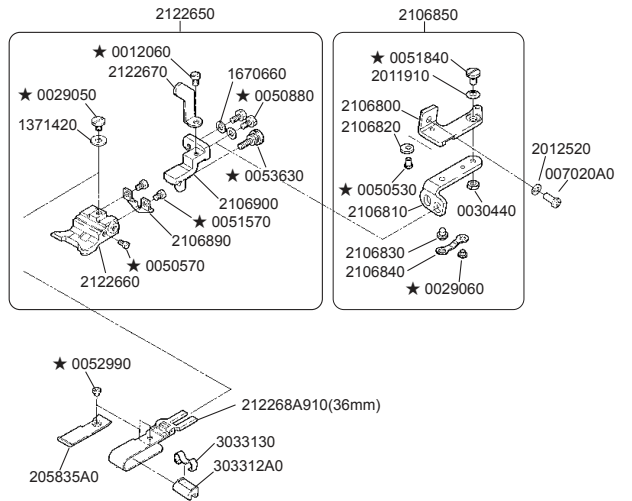

31

●MX5205-12
裾引き(Blindhemming)

★印はインチネジです。 ★=inchi size **G** ゲージパーツ表参照 Refer to the gauge parts list.

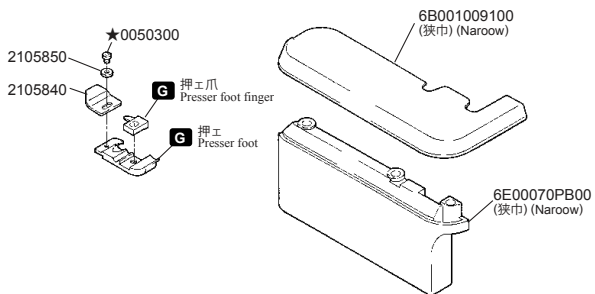
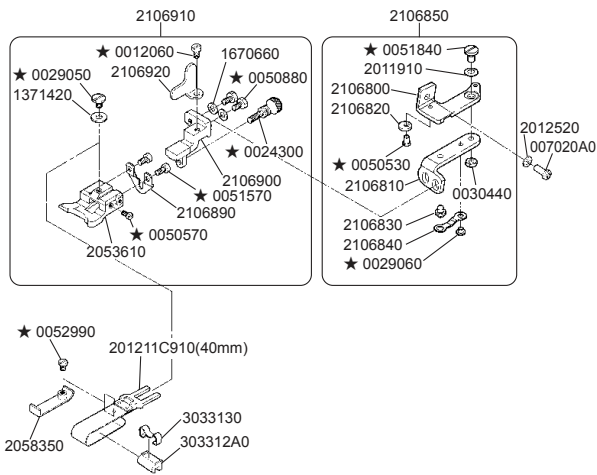

32

●MX5204-02,32R2
MX5214-M03,M53,54

※印は非売品です。 ★印はインチネジです。 ★=inchi size **G** ゲージパーツ表参照 Refer to the gauge parts list.

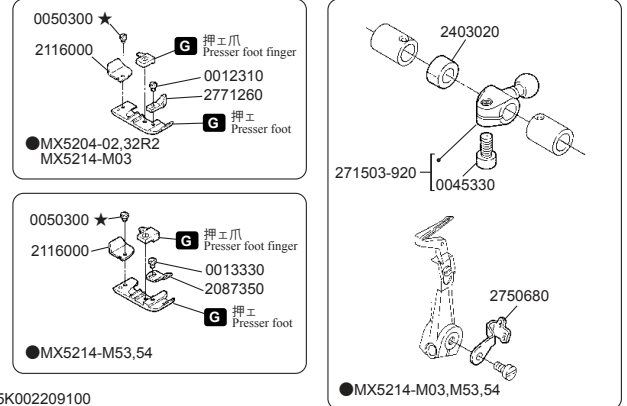

5K002209100

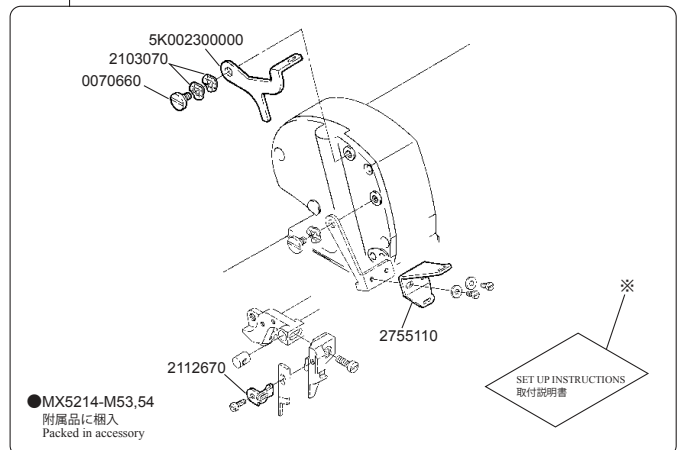

★印はインチネジです。
★=inchi size

●MX5214-54
テープ入れ用
(Attaching tape)

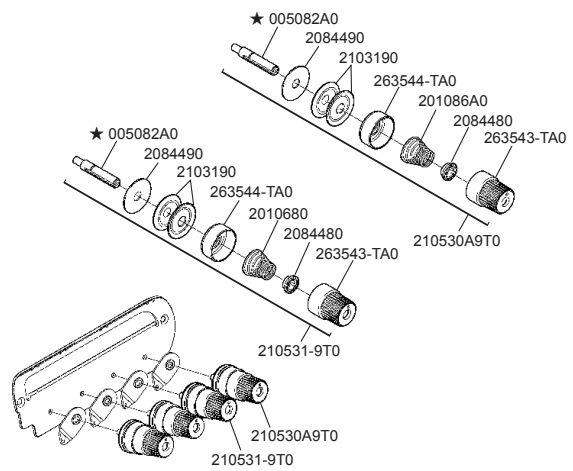
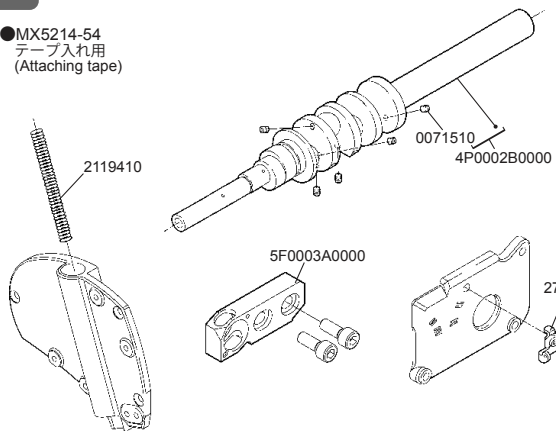

MX3200 ゲージパーツ表

MX3200 GAUGE PARTS LIST



マシン形式 MACHINE TYPE /SPEC	ゲージ GAUGE		針板 NEEDLE PLATE	主送り歯(組) MAIN FEED DOG ASSY.	主送り歯本体 MAIN FEED DOG	補助送り歯 AUX. FEED DOG	差動送り歯 DIFF. FEED DOG	押エ(組) PRESSER FOOT ASSY.	上ルーパー UPPER LOOPER	下ルーパー LOWER LOOPER	二重環ルーパー CHAINSTITCH LOOPER	上メス UPPER KNIFE
	NG	SW										
MX3216-02/233	3	4	277513R400	277323-160	(277324-160)	(277318-130)	277325-160	2771180	2770100	2770150	2770180	201121A0
MX3216-03/333	3	4	277517R400	277327-160	(277328-160)	(277318-130)	277330-160	2771180	2770100	2770150	2770180	201121A0
	5	5	277516R500				277329-160					
MX3244-03/333	3×2	4	277518R400	277327-160	(277328-160)	(277318-130)	277329-160	277118A0	277010A0	2770150	2770180	201121A0
MX3216-A04/435	5	6	277524T602	277337-252	(277427-250)	(277428-200)	277339-251	2771220	2770100	2770150	2770180-C0	201121A0
MX3216-42/233	3	4	277521R400	277334-160	(277335-160)	(277318-130)	277336-160	2771200	277010A0	2770150	2770180	201121A0
MX3216-42P2/233	3	4	277521R400	277334-160	(277335-160)	(277318-130)	277336-160	204502A1	277010A0	2770150	2770180	201121A0



マシン形式 MACHINE TYPE /SPEC	ゲージ GAUGE		下メス LOWER KNIFE	オーバ針受け OVERLOCK NEEDLE GUARD		二重環針受け CHAINSTITCH NEEDLE		針留 NEEDLE HOLDER	針 NEEDLE
	NG	SW		前 FRONT	後 REAR	前 FRONT	後 REAR		
MX3216-02/233	3	4	2022950	2770070	2770040	2770080	2770060	277027-921	DC×27 #11
MX3216-03/333	3	4	2022950	2770070	2770040	2770080	2770060	277027-921	DC×27 #14
	5	5						277028-920	
MX3244-03/333	3×2	4	2022950	2770070	2770040	2770080	2770060	277030-920	DC×27 #11
MX3216-A04/435	5	6	2022950	2770070	2770040	2770080	2770060	277029-920	DC×27 #21
MX3216-42/233	3	4	2022950	2770070	2770040	2770080	2770060	277027-921	DC×27 #14
MX3216-42P2/233	3	4	2022950	2770070	2770040	2770080	2770060	277027-921	DC×27 #14

MX5200 ゲージパーツ表

MX5200 GAUGE PARTS LIST



マシン形式 MACHINE TYPE /SPEC	ゲージ GAUGE		針板 NEEDLE PLATE	主送り歯(組) MAIN FEED DOG ASSY.	主送り歯本体 MAIN FEED DOG	補助送り歯 AUX. FEED DOG	差動送り歯 DIFF. FEED DOG	押エ PRESSER FOOT	押エ爪 PRESSER FOOT FINGER	上ルーパー UPPER LOOPER	下ルーパー LOWER LOOPER	上メス UPPER KNIFE
	NG	SW										
MX5204-02/233	—	4	277504R400	277303-16F0	(277304-16F0)	(277318-130)	277305-16F0	201230C0	2103710	2770100	2770150	201121A0
MX5204-02H/233	—	4	277500P400	277300-16F0	(277301-16F0)	(277318-130)	277302-16F0	211991A0	277103A0	2770100	2770150	201121A0
MX5214-M03/333	2	4	277505R400	277303-16F0	(277304-16F0)	(277318-130)	277305-16F0	201230C0	2103740	277010A0	2770340	201121A0
MX5205-12/223	—	4	277500P400	277300-16F0	(277301-16F0)	(277318-130)	277302-16F0	201152E0	2771030	2770100	2770150	201121A0
MX5204-32R2/223L	—	1.5	277502P150	277315-16F0	(277301-16F0)	(277319-130)	277302-16F0	2027990	2055250	2770100	2770150	201121A0
MX5214-M53/333	2	4	277505R400	277303-16F0	(277304-16F0)	(277318-130)	277305-16F0	2771120	2086510	277010A0	2770340	201121A0
MX5214-54/433	2	4	277507R400	277378-16F0	(277379-16F0)	(277318-130)	277380-16F0	2771110	2771040	277011B0	277015B0	201121A0



マシン形式 MACHINE TYPE /SPEC	ゲージ GAUGE		下メス LOWER KNIFE	針受け NEEDLE GUARD		針留 NEEDLE HOLDER	針 NEEDLE
	NG	SW		前 FRONT	後 REAR		
MX5204-02/233	—	4	2022950	2770050	2770040	179630-920	DC×27 #9
MX5204-02H/233	—	4	2022950	2770050	2770040	179630-920	DC×27 #9
MX5214-M03/333	2	4	2022950	2770050	2770040	277022-920	DC×27 #9
MX5205-12/223	—	4	2022950	2770050	2770040	179630-920	DC×27 #9
MX5204-32R2/223L	—	1.5	2022950	2770050	2770040	179630-920	DC×27 #11
MX5214-M53/333	2	4	2022950	2770050	2770040	277022-920	DC×27 #9
MX5214-54/433	2	4	2022950	2770050	2770040	277022-920	DC×27 #11

ペガサスミシン製造株式会社

本社 〒 553-0002 大阪市福島区鷺洲 5-7-2 TEL (06)6458-4739
FAX (06)6454-8785

PEGASUS SEWING MACHINE MFG. CO., LTD.

5-7-2, Sagisu, Fukushima-ku, Osaka 553-0002, Japan. Phone : (06)6458-4739
Telefax : (06)6454-8785

Cat. No. 9B900200001 November 2003

©2003 PEGASUS SEWING MACHINE MFG. CO., LTD.

このパーツチェッカーに記載されている内容は、改良のため予告なく変更することがあります。

The description in this PARTS CHECKER is subject to change without prior notice for improvement.