

FINEST QUALITY

Union Special[®]
LEWIS • COLUMBIA

INDUSTRIAL
SEWING
MACHINES

KATALOG NR. 274

(Beilage zu Katalog Nr. 257)

GEBRAUCH DES KATALOGS

Dies ist ein Zusatzkatalog zu Katalog Nr. 257 und sollte nur in Verbindung mit diesem benutzt werden. Nur die Teile, die in den Maschinen 31200 P-12 und Q-12 verwendet werden und nicht in den Maschinen 31200 F, M vorkommen, sind in diesem Katalog bildlich dargestellt. Neben der Bildseite befindet sich das Verzeichnis der Teile mit ihren Teilnummern, Benennung und Angabe der erforderlichen Stückzahl.

MASCHINEN-TYPE

31200 P-16

2-Nadel, 2-Greifer, Side Wheel Zylinder-Doppelkettenstich-Nähmaschine. Zum Unternähen von Band an Schulter- und Kragennähten von Strickwaren.

Ausgerüstet mit unterem Bandrollenhalter und Apparat für ein vorgeschchnittenes Band von $3/4" = 19$ mm Breite und $5/16" = 8$ mm Fertigbreite.

Transport: Einfacher Transport
Stichtype: 401

Stichlänge: 8 - 14 Stiche pro Zoll = 1,8 mm - 3,2 mm

Standardeinstellung: 12 Stiche pro Zoll = 2 mm

Maximale Stichzahl: 3500 Stiche/min.

Greiferabstand: $13/64" = 5,16$ mm

Nadeltype: 128 GAS-032

Nadelfaden: 70 - 2 weich

Greiferfaden: 70 - 2 weich

31200 Q-16

2-Nadel, 2-Greifer, Side Wheel Zylinder-Doppelkettenstich-Nähmaschine. Zum Aufnähen von Band an Schulter- und Kragennähten von Strickwaren.

Ausgerüstet mit oberem Bandrollenhalter und Apparat für ein vorgeschchnittenes Band von $3/4" = 19$ mm Breite und $5/16" = 8$ mm Fertigbreite.

Transport: Einfacher Transport
Stichtype: 401

Stichlänge: 8 - 14 Stiche pro Zoll = 1,8 mm - 3,2 mm

Standardeinstellung: 12 Stiche pro Zoll = 2 mm

Maximale Stichzahl: 3500 Stiche/min.

Greiferabstand: $13/64" = 5,16$ mm

Nadeltype: 128 GAS-032

Nadelfaden: 70 - 2 weich

Greiferfaden: 70 - 2 weich

CATALOG NO. 274

(Supplement to Catalog No. 257)

APPLICATION OF CATALOG

This catalog is a supplement to Catalog No. 257 and should be used in conjunction therewith. Only those parts used on Styles 31200 P-16 and Q-16, but not on Styles 31200 F, M are illustrated and listed at the back of this catalog. On the page opposite the illustration will be found a listing of the parts with their part numbers, description and the number of pieces required.

STYLE OF MACHINE

31200 P-16

Two Needle, two Looper, Side Wheel Cylinder Machine for Taping Shoulders and Collar Seams on Knitwear.

Equipped with bottom tape reel and folders for a precut $3/4" = 19$ mm tape to finish $5/16" = 8$ mm Plain Feed, Seam Spec. 401.

Feed: Plain Feed

Seam Spec.: 401

Stitch Range: 8 - 14 S. P. I. = 1,8 mm - 3,2 mm

Standard setting: 12 S. P. I. = 2 mm

Maximum Speed: 3500 R. P. M.

Looper Gauge: $13/64" = 5,16$ mm

Needle Type: 128 GAS-032

Needle Thread: 70 - 2 soft

Looper Thread: 70 - 2 soft

31200 Q-16

Two Needle, two Looper, Side Wheel Cylinder Machine for Taping Shoulders and Collar Seams on Knitwear.

Equipped with top tape reel and Presser Foot with Folder for a precut $3/4" = 19$ mm tape to finish $5/16" = 8$ mm Plain Feed, Seam Spec. 401.

Feed: Plain Feed

Seam Spec.: 401

Stitch Range: 8 - 14 S. P. I. = 1,8 mm - 3,2 mm

Standard setting: 12 S. P. I. = 2 mm

Maximum Speed: 3500 R. P. M.

Looper Gauge: $13/64" = 5,16$ mm

Needle Type: 128 GAS-032

Needle Thread: 70 - 2 soft

Looper Thread: 70 - 2 soft

31200 P-16

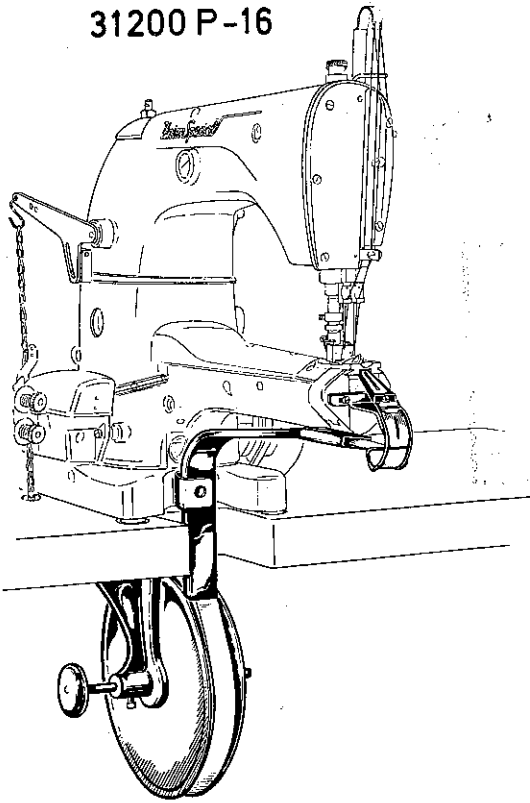

Pos. Nr.	Teil Nr.	Beschreibung	Description	Anzahl
Ref. No.	Part No.			Amf. Req.
1	22561	Schraube	Screw	2
2	23105	Bandapparat	Foilder	1
3	77 L	Schraube (gehört zur Endkappe 31279 P)	Screw (belongs to End Cover 31279 P)	1
4	23105 A	Bandführung	Tape Guide	1
5	25 S	Schraube	Screw	1
6	SC 299	Holzschraube	Wood Screw	4
7	21385 B	Spulenchse	Spool Holder Axle	1
8	201 A	Spulenbock kpl.	Loower Holder Frame cpl.	1
9	22508	Schraube	Screw	1
10	21177 A	Stelling mit Druckfeder kpl.	Tape Reel Tension Spring cpl.	1
11	1349 A-5	Feder	Spring	1
12	22647 K-24	Flügelschraube	Thumb Screw	1
13	21178	Bandrollenscheiben	Tape Holder Disc	2

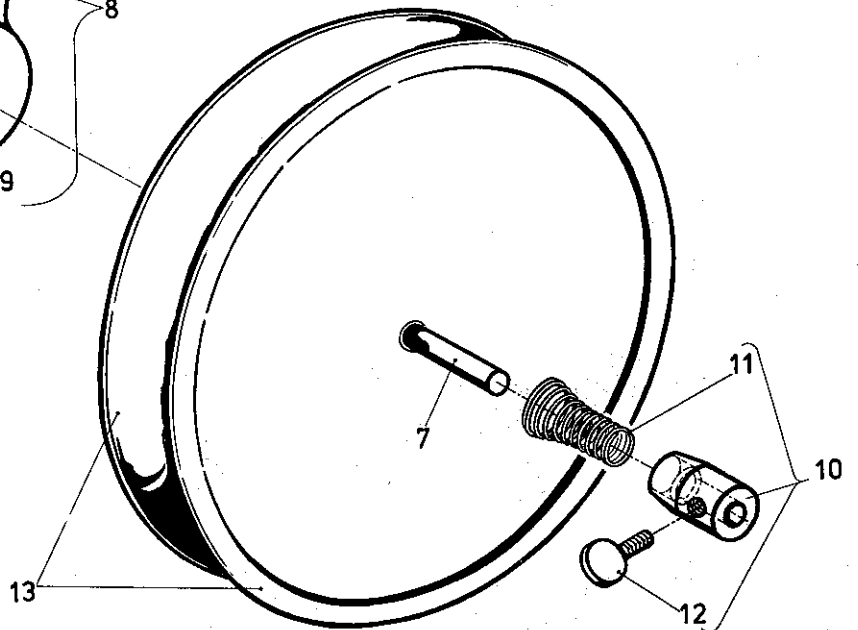
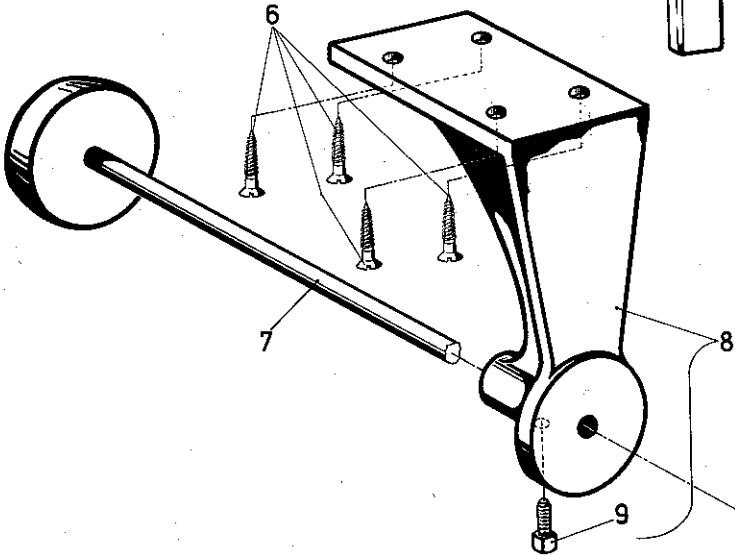
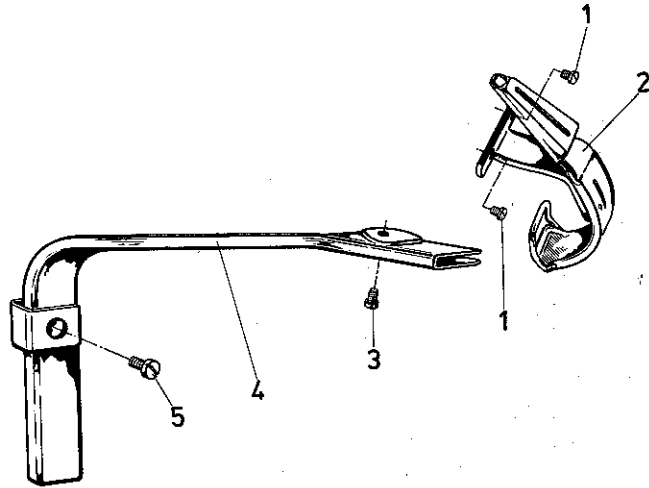

<u>Pos.Nr.</u>	<u>Teil Nr.</u>	<u>Beschreibung</u>	<u>Description</u>	<u>Anzahl</u>
<u>Ref. No.</u>	<u>Part No.</u>			<u>Amt. Req.</u>
1	21177 A	Stellring mit Druckfeder kpl.	Tape Reel Tension Spring cpl.	1
2	22647 K-24	Flügel schraube	Thumb Screw	1
3	1349 A-5	Feder	Spring	1
4	21114 W	Spulenachse	Spool Pin	1
5	258	Mutter	Nut	3
6	23105 B	Bandrollenträger	Tape Reel Bracket	1
7	21182 AM	Bandrechen	Tape Tension Bracket	1
8	22528	Schraube	Screw	1
9	88 D	Schraube	Screw	1
10	52782 C	Gewindebolzen	Stud	2
11	31282	Kopfdeckel	Head Cover	1
12	22569	Schraube	Screw	3
13	31270	Fadenabzugshaken	Pull-off Wire	1
14	22565	Schraube	Screw	1
15	21178	Bandrollenscheibe	Tape Holder Disc	2

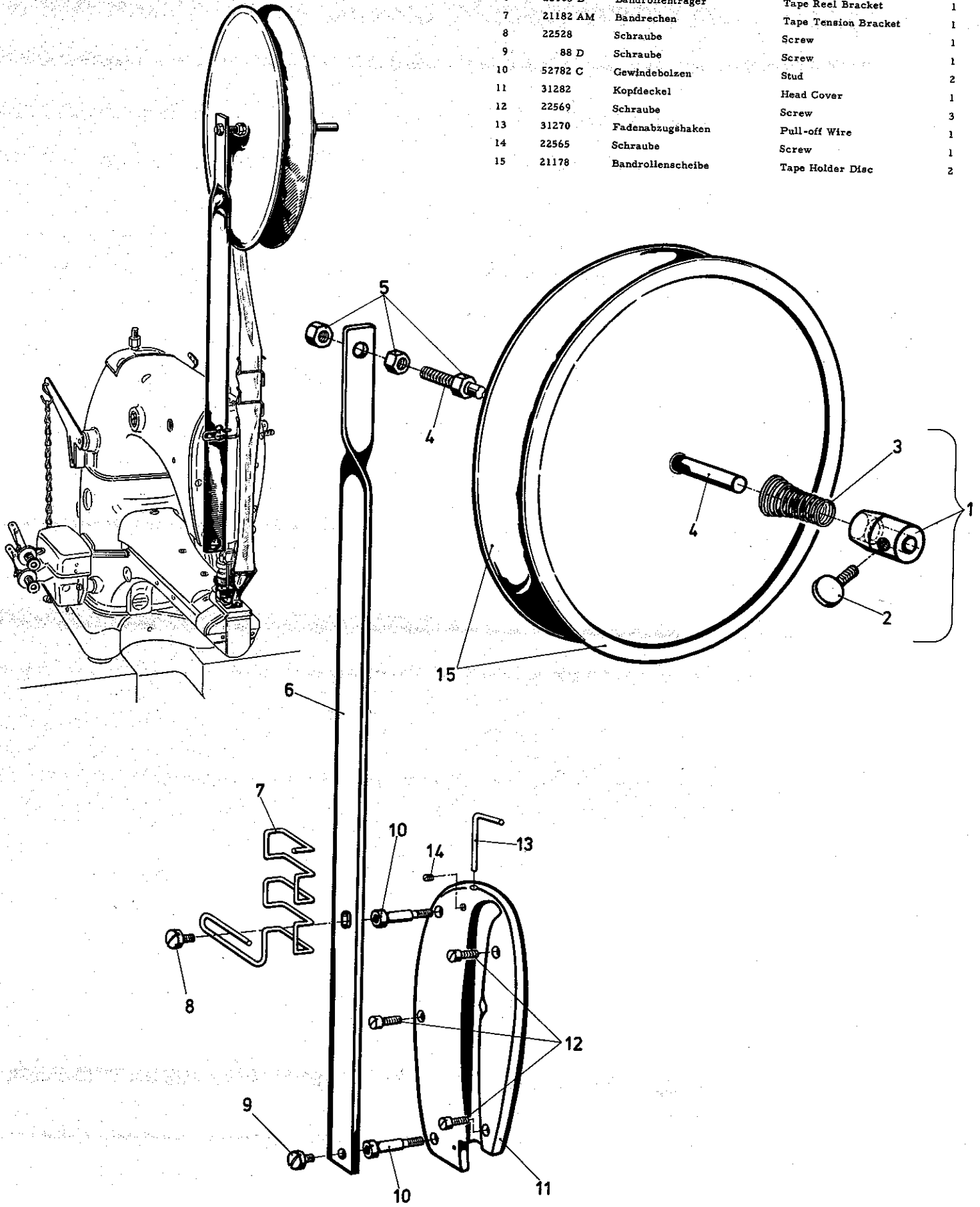

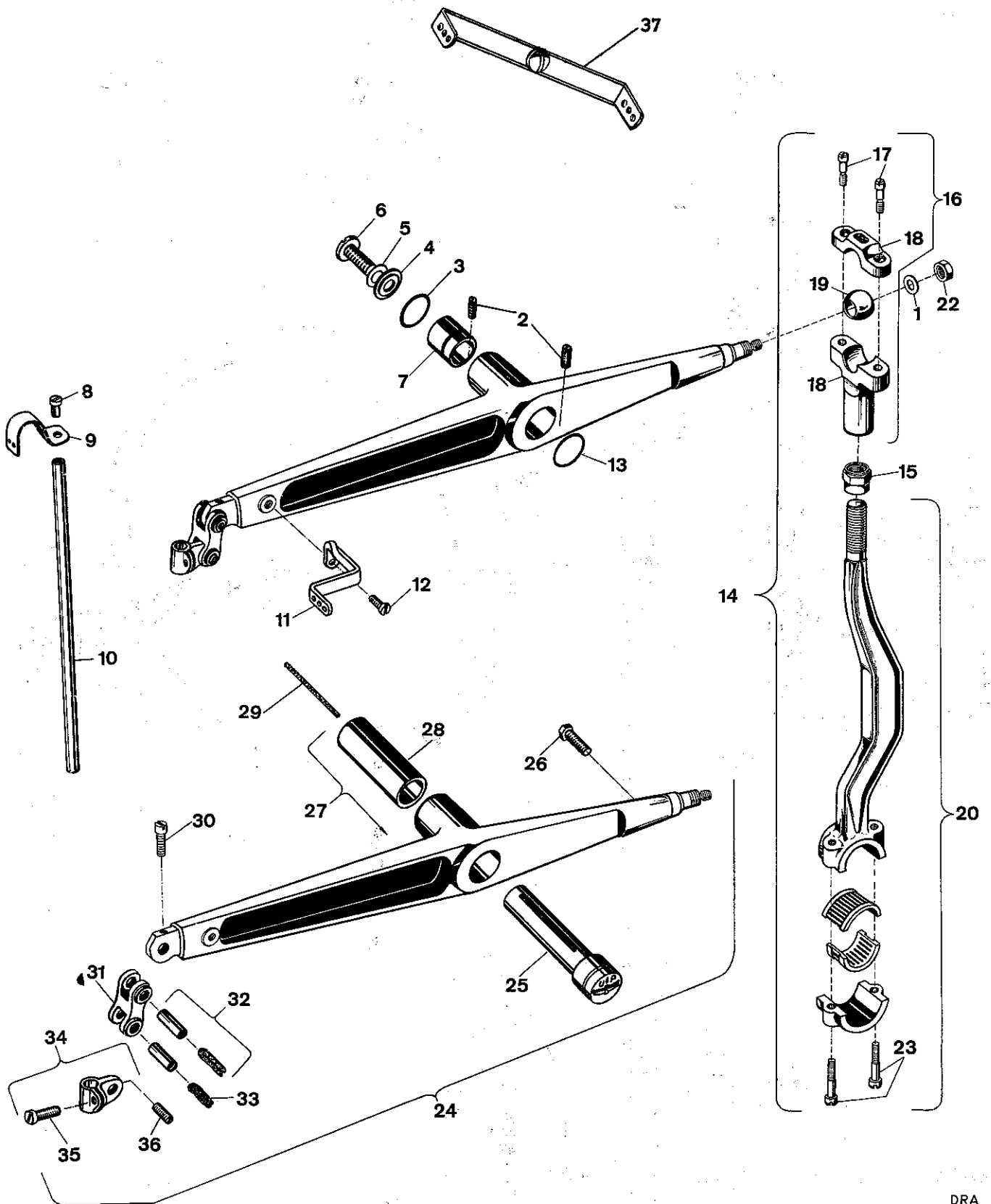

<u>Pos. Nr.</u>	<u>Teil Nr.</u>	<u>Beschreibung</u>	<u>Description</u>	<u>Anzahl</u>
<u>Ref. No.</u>	<u>Part No.</u>			<u>Amt. Req.</u>
1	51216 N	SCHEIBE	WASHER	1
2	719	SCHRAUBE	SCREW	2
3	660-212	ÖLABSTREIFRING	OIL SEAL RING	1
4	51250 D	U'LEGSCHIEBE	WASHER	1
5	51250 F	DICHTUNGSSCHIEBE	GASKET	1
6	22586 R	SCHRAUBE	SCREW	1
7	51150	ANSCHLAGBUCHSE	NEEDLE LEVER SHAFT STOP COLLAR	1
8	22768	Schraube	Screw	1
9	31158 A	Fadenführung auf Nadelstange	Needle Bar Thread Eyelet	1
10	31117	Nadelstange	Needle Bar	1
11	33758 D	FADENFÜHRUNG AM NADELHEBEL	NEEDLE LEVER THREAD EYELET	1
12	22768	Schraube	Screw	1
13	660-212	ÖLABSTREIFRING	OIL SEAL RING	1
14	G 29476 WA	NADELHEBELVERBINDUNG KPL.	NEEDLE LEVER ROD ASSEMBLY	1
15	15430 C	Mutter, Linksgewinde	Nut, left Thread	1
16	G 29066 C	KUGELLAGER KOMPL.	NEEDLE LEVER BALL JOINT	1
17	G 97 AA	SCHRAUBE	SCREW	2
18	31132	LAGERSCHALE	NEEDLE LEVER BALL JOINT BEARING	1
19	51216 L	KUGEL	BALL	1
20	31116 H	NADELHEBELVERBINDUNG	NEEDLE LEVER ROD	1
22	51216 P	MUTTER	NUT	1
23	G 75 A	SCHRAUBE	SCREW	2
24	G 29348 G	NADELHEBEL KOMPL.	NEEDLE LEVER ASSEMBLY	1
25	51250 E	NADELHEBELBOLZEN	NEEDLE LEVER STUD	1
26	BP 108	Schraube	Screw	1
27	31115 A	NADELHEBEL	NEEDLE LEVER	1
28	51250 A	BÜCHSE	NEEDLE LEVER BUSHING	1
29	666-170	ÖLDOCHT	OIL WICK	1
30	77	Schraube	Screw	1
31	54	Verbindungsgelenk	Needle Bar Link	1
32	51054	Konischer Stift	Link Pin	2
33	666-149	Decht	Lubricating Felt	2
34	51254 H	Mitnehmer	Needle Bar Connection	1
35	22562 A	Schraube	Screw	1
36	78	Schraube	Screw	1
37	G 52758	FADENFÜHRUNG (AM GEHÄUSEOBERTEIL)	THREAD GUIDE (ON HOUSING UPPER PART)	1

Teile dessen Beschreibungen in großen Buchstaben geschrieben sind, sind Teile die nur in Maschinen Kl. 31200 P-16 und Q-16 verwendet werden. Die anderen Teile werden auch in Maschinen Kl. 31200 F und M verwendet und nur für die Veranschaulichung dargestellt.

Parts whose description are written in capital letters, are those parts used only on styles 31200 P-16 and Q-16. The other parts are also used on styles 31200 F and M and are shown for illustration only.

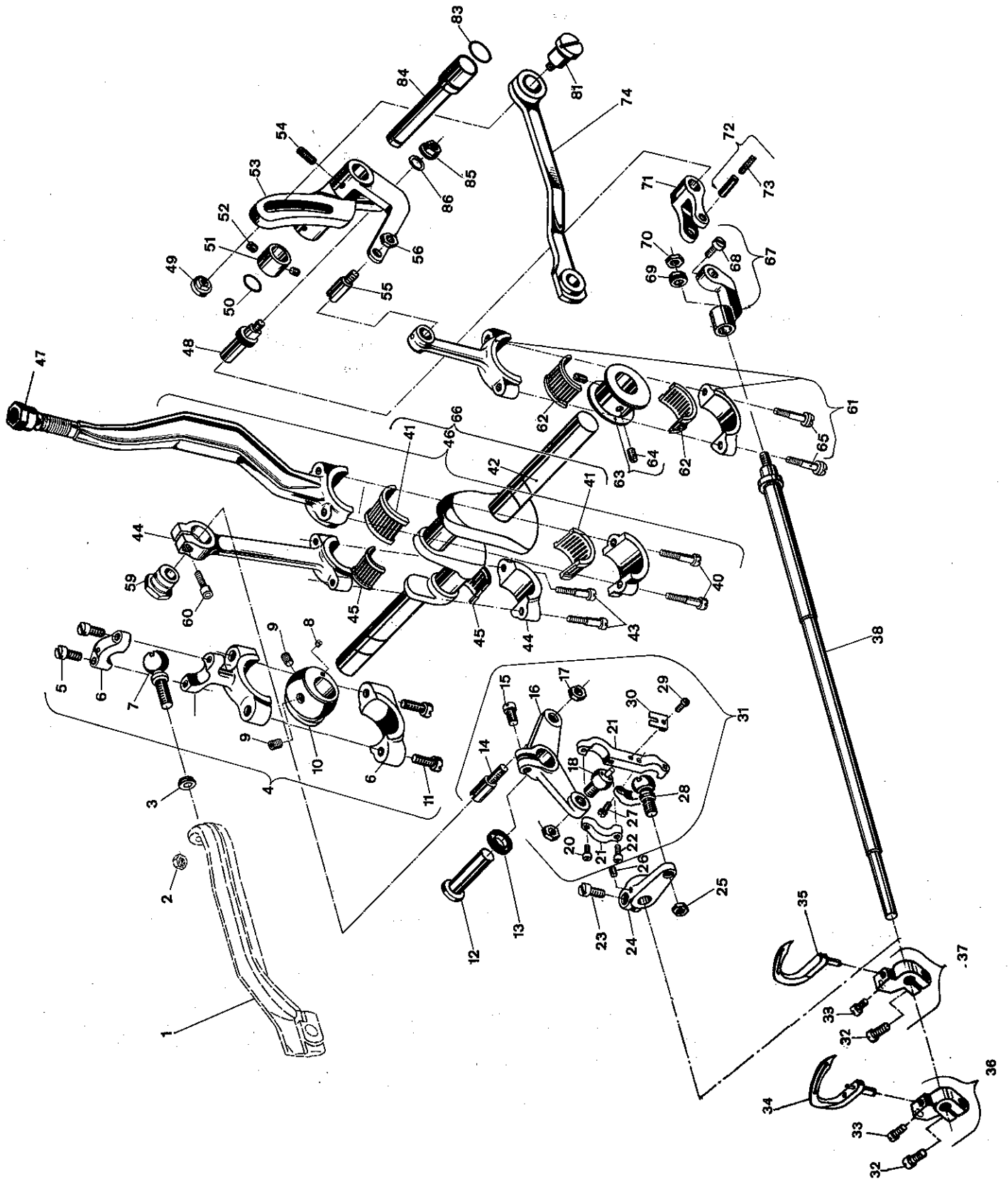

<u>Pos.Nr.</u>	<u>Teil Nr.</u>	<u>Beschreibung</u>	<u>Description</u>	<u>Anzahl</u>
<u>Ref. No.</u>	<u>Part No.</u>			<u>Amt. Req.</u>
43	75 A	Schraube	Screw	2
44	31116 J	GREIFERANTRIEBSVERBINDUNGS- STANGE	LOOPER DRIVE LEVER CONNECTION	1
45	999-38	Nadelkäfig f. Greiferantriebslager	Needle Bearing	2
46	31116 H	NADELHEBELVERBINDUNG	NEEDLE LEVER CONNECTION	1
47	15430 C	Mutter, Linksgewinde	Nut, left Thread	1
48	11963	Kulissenbolzen	Stud for Looper Avoid Link	1
49	31133 M	Stellmutter	Adjusting Nut	1
50	999-30	O-Ring	"O" Ring	1
51	HA 482 A	Stellring	Collar	1
52	88	Schraube	Screw	2
53	31142 Q	Transport und Greiferantriebshebel	Feed Drive and Looper Avoid Drive Lever	1
54	22894 W	Schraube	Screw	1
55	31142 M	Gelenkbolzen	Link Pin	1
56	12538	Mutter	Nut	1
59	31142 D	EXZENTER	ECCENTRIC	1
60	22729 L	SCHRAUBE	SCREW	1
61	31116 C	TRANSPORTANTRIEBSVERBINDUNG	FEED DRIVE AND LOOPER AVOID CONNECTION ASSEMBLY	1
62	999-40	Nadellager f. Transport und Greiferantriebsexzenter	Needle Bearing	2
63	31106	Exzenter	Eccentric	1
64	22894 C	Schraube	Screw	2
65	G 22559 C	Schraube	Screw	2
66	G 29476 WA	KURBELWELLE MIT NADELHEBEL- VERBINDUNG	CRANKSHAFT WITH NEEDLE LEVER CONN.	1
67	31144 A	Gelenk	Looper Avoid Link	1
68	77	Schraube	Screw	1
69	462	Mutter	Nut	1
70	12538	Mutter	Nut	1
71	G 12055 N	Greiferhebelgelenk	Looper Avoid Drive Link	1
72	51054	Gelenkstift	Link Pin	1
73	666-149	Docht	Oil Wick	1
74	31133 H	VERBINDUNGSSTANGE KOMPLETT FÜR EINFACH-TRANSPORT	CONNECTION ROD FOR PLAIN FEED MACHINE	1
81	31133 K	ANSATZSCHRAUBE	SHOULDER SCREW	1
83	999-32	O-Ring	"O" Ring	1
84	31142 P	Achse für 31142 Q	Bar for 31142 Q	1
85	462	Mutter	Nut	1
86	21657 E	Scheibe	Washer	1

Teile dessen Beschreibungen in großen Buchstaben geschrieben sind, sind Teile die nur in Maschinen Kl. 31200 P-16 und Q-16 verwendet werden. Die anderen Teile werden auch in Maschinen Kl. 31200 F und M verwendet und nur für die Veranschaulichung dargestellt.

Parts whose description are written in capital letters, are those parts used only on styles 31200 P-16 and Q-16. The other parts are also used on styles 31200 F and M and are shown for illustration only.

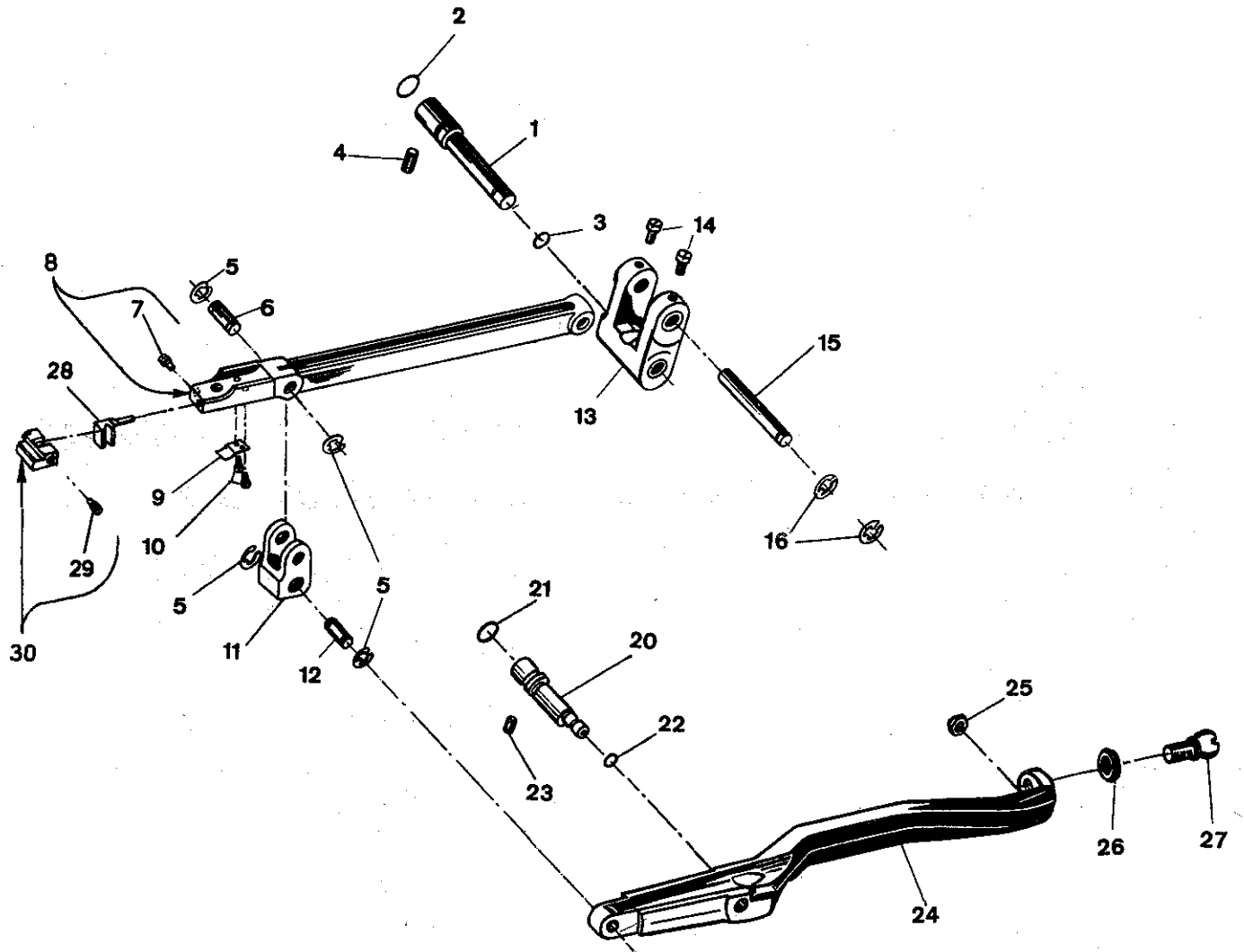

<u>Pos.Nr.</u>	<u>Teil Nr.</u>	<u>Beschreibung</u>	<u>Description</u>	<u>Anzahl</u>
<u>Ref. No.</u>	<u>Part No.</u>			<u>Amt. Req.</u>
1	31135 C	Querachse	Feed Rocker Shaft	1
2	999-34	O-Ring	"O" Ring	1
3	999-33	O-Ring	"O" Ring	1
4	22894 C	Schraube für 31135 C	Screw for 31135 C	1
5	660-199	Sicherungsring	Retaining Ring	4
6	31136 A	Gelenkbolzen	Link Pin	2
7	99305	Schraube	Screw	1
8	31234	Transporteurträger	Feed Bar	1
9	31134 L	Blattfeder	Spring	1
10	G 41228 A	Schraube	Screw	2
11	31136 E	Transporteurträgerführung	Feed Bar Guide	1
12	31136 A	Gelenkbolzen	Link Pin	1
13	31135 E	Transportrahmen	Feed Rocker	1
14	90	Schraube	Screw	2
15	31135 G	ACHSE FÜR 31135 E	FEED BAR SHAFT FOR 31135 E	1
16	96275	Sicherungsring	Retaining Ring	2
20	31139 A	Exzenter-Bolzen	Feed Bar Adjusting Pin	1
21	999-30	O-Ring	"O" Ring	1
22	999-31	O-Ring	"O" Ring	1
23	22894 C	Schraube für 31139 A	Screw for 31139 A	1
24	31139 C	TRANSPORTHÜBHEBEL	FEED ROCKER ARM	1
25	258	Mutter	Nut	1
26	31146	Scheibe	Washer	1
27	35746 C	Kugelschraube	Ball	1
28	31225 F	NADELANSCHLAGHALTER	HOLDER FOR NEEDLE GUARD	1
29	99306	Schraube	Screw	1
30	31225 A	NADELANSCHLAG	NEEDLE GUARD	1

Teile dessen Beschreibungen in großen Buchstaben geschrieben sind, sind Teile die nur in Maschinen Kl. 31200 P-16 und Q-16 verwendet werden. Die anderen Teile werden auch in Maschinen Kl. 31200 F und M verwendet und nur für die Veranschaulichung dargestellt.

Parts whose description are written in capital letters, are those parts used only on styles 31200 P-16 and Q-16. The other parts are also used on styles 31200 F and M and are shown for illustration only.

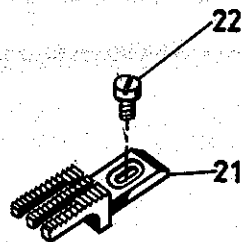
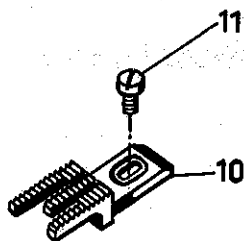
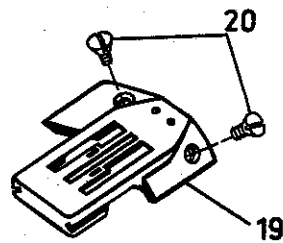
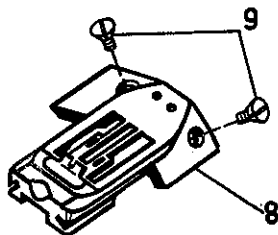
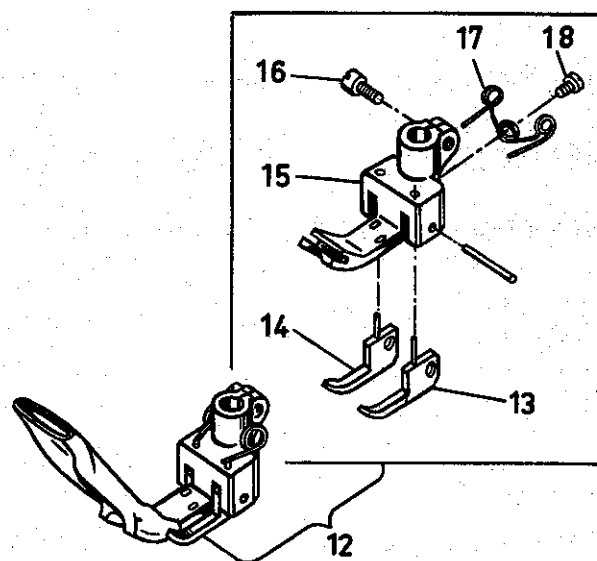
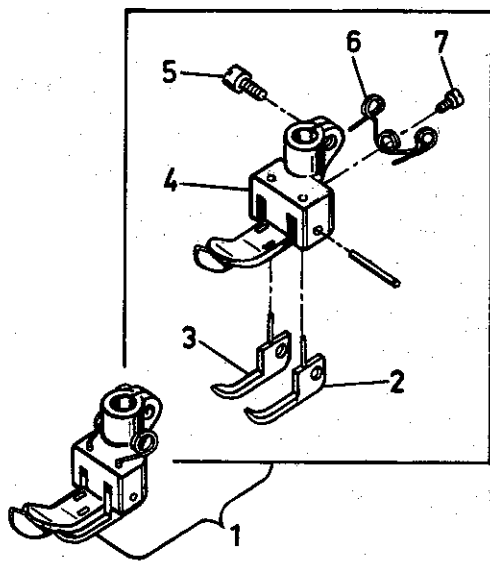

<u>Pos. Nr.</u>	<u>Teil Nr.</u>	<u>Beschreibung</u>	<u>Description</u>	<u>Anzahl</u>
<u>Ref. No.</u>	<u>Part No.</u>			<u>Amt. Req.</u>
1	31220 P-16	Drückerfuß komplett für Masch. Klasse 31200 P-16	Presser Foot Assembly for Machine Style 31200 P-16	1
2	3041	Drückerfuß-Seitenteil, rechts	Yielding Section, right	1
3	3042	Drückerfuß-Seitenteil, links	Yielding Section, left	1
4	31230 P-16	Hauptteil	Bottom	1
5	91	Schraube	Screw	1
6	11940	Feder	Spring	1
7	605	Schraube	Screw	1
8	31224 P-16	Stichplatte	Throat Plate	1
9	22524	Schraube	Screw	2
10	31205 P	Transporteur	Feed Dog	1
11	99293	Schraube	Screw	1
12	31220 Q-16	Drückerfuß komplett für Masch. Klasse 31200 Q-16	Presser Foot Assembly for Machine Style 31200 Q-16	1
13	3041	Drückerfuß-Seitenteil, rechts	Yielding Section, right	1
14	3042	Drückerfuß-Seitenteil, links	Yielding Section, left	1
15	31230 Q-16	Hauptteil	Bottom	1
16	91	Schraube	Screw	1
17	11940	Feder	Spring	1
18	605	Schraube	Screw	1
19	31224 Q-16	Stichplatte	Throat Plate	1
20	22524	Schraube	Screw	2
21	31205 Q	Transporteur	Feed Dog	1
22	99293	Schraube	Screw	1

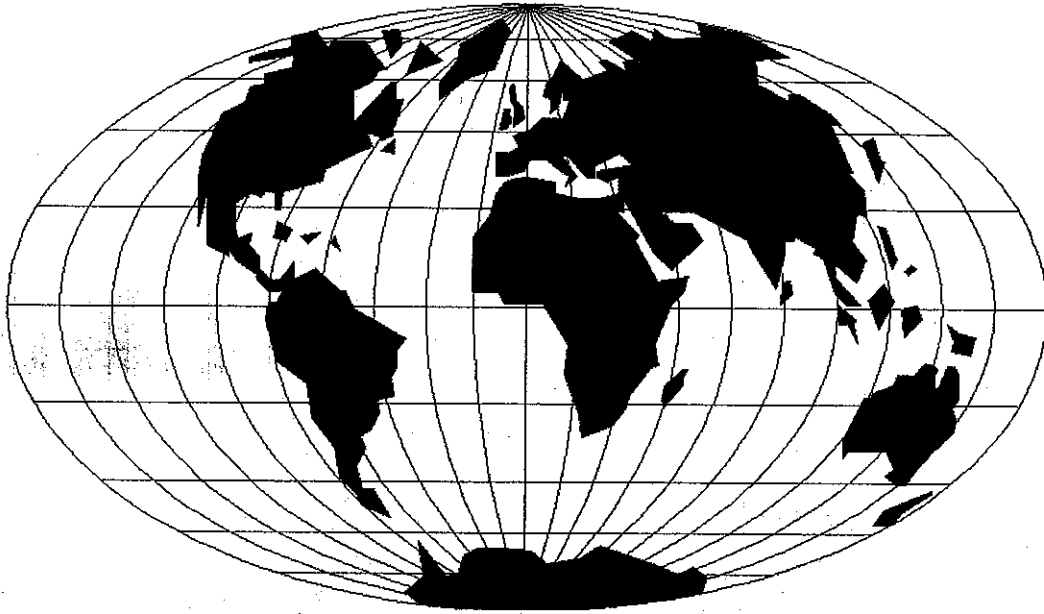

WORLDWIDE SALES AND SERVICE

Union Special Corporation maintains sales and service facilities throughout the world. These offices will aid you in the selection of the right sewing equipment for your particular operation. Union Special Corporation representatives and service technicians are factory trained and are able to serve your needs promptly and efficiently. Whatever your location, there is a qualified representative to serve you.

Brussels, Belgium
Charlotte, N.C.
Commerce, CA
El Paso, TX
Hong Kong, China
Huntley, IL
Leicester, England
Lille, France
Miami, FL
Milan, Italy
Mission, TX
Möglingen, Germany
Montreal, Quebec
Osaka, Japan

Other Representatives throughout
all parts of the world.



Union Special[®]
INDUSTRIAL SEWING EQUIPMENT