

mitsubishi

三菱工業用ミシン部品カタログ

Industrial Sewing Machine Parts Catalog

Model PLK-E2516R

	目次	CONTENTS	Page
A	本体構成	Construction	1
B	本体関係(1)	Arm bed & it's accessories (1)	2
C	本体関係(2)	Arm bed & it's accessories (2)	4
D	本体関係(3)	Arm bed & it's accessories (3)	6
E	縫い機構(1)	Sewing mechanism (1)	8
F	縫い機構(2)	Sewing mechanism (2)	10
G	中押え機構	Presser bar lifting mechanism	12
H	糸切り機構	Thread trimming mechanism	14
J	X-Yテーブル機構	X-Y table mechanism	16
K	外押え機構(1)	Work holder mechanism (1)	18
L	外押え機構(2)	Work holder mechanism (2)	20
M	ワイパー機構	Wiper mechanism	22
N	給油機構	Oil lubrication mechanism	24
P	配線・配管関係	Cable component & Pneumatic control unit	26
Q	テーブル関係	Table & Stand	28
R	付属品(1)	Accessories (1)	30
S	付属品(2)	Accessories (2)	32
T	オプションパーツ	Option parts	34
	索引	Index	36

部品コードの採番形式

MITSUBISHI SPARE PARTS No. Designation system

1. 部品コードについて CONCERNING PARTS CODE.

部品をご注文される場合は、部品コードをお知らせください。

Please inform the part number, when these parts are ordered.

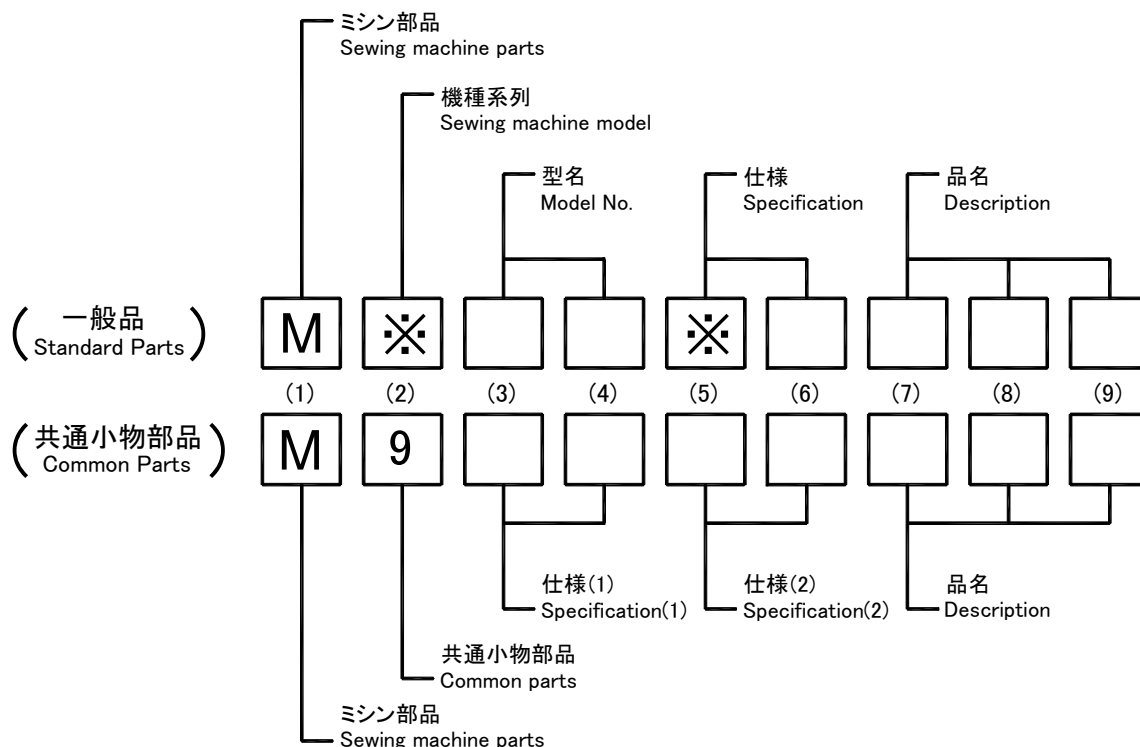

[例 Example]

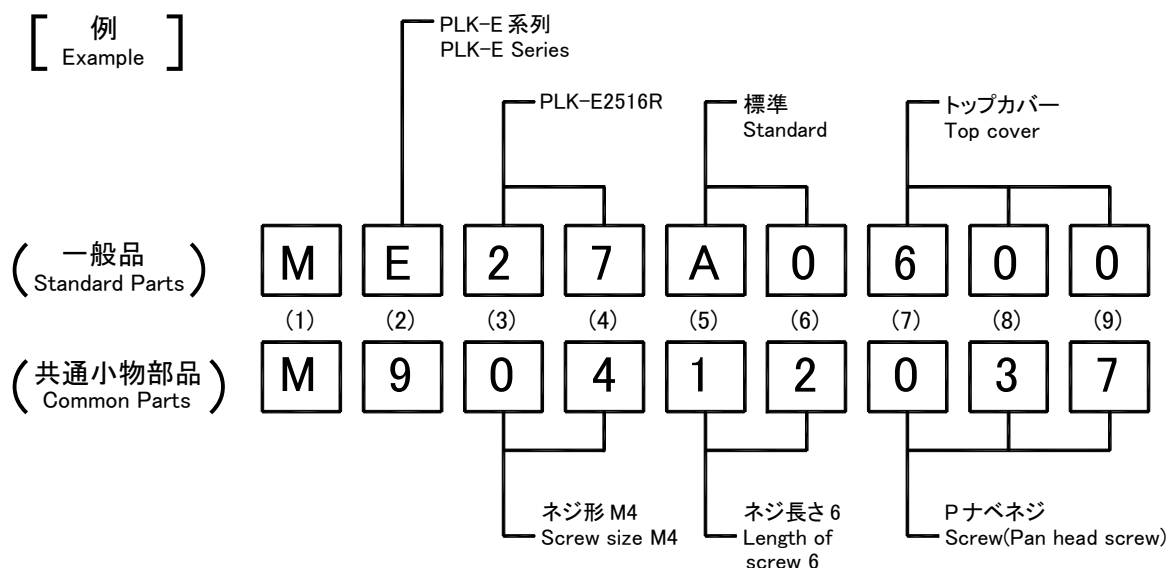

2. 変更マークについて CONCERNING MODIFICATION MARK.

変更マーク欄に*記号のある部品は、形状、寸法などの変更履歴がありますので、ご注文の際にはご使用の製品の製造番号と合わせてご覧ください。

The parts marked with * in the modification column has been changed the shape or size etc. So when these modified parts are ordered please inform the serial number of the sewing machine.

注: 一般品についての機種型名は、その部品が最初に使用された機種型名を示します。

従って長期にわたる場合は、機種の変更が行われるため、当初の機種以外の機種で使用されている場合があります。

Sewing machine Models, of Standard Parts are Indicated model of these parts are registered firstly. Parts are used for not only the indicated model, but also another models, in reason of New development, improvement after.

A 全体構成
CONSTRUCTION

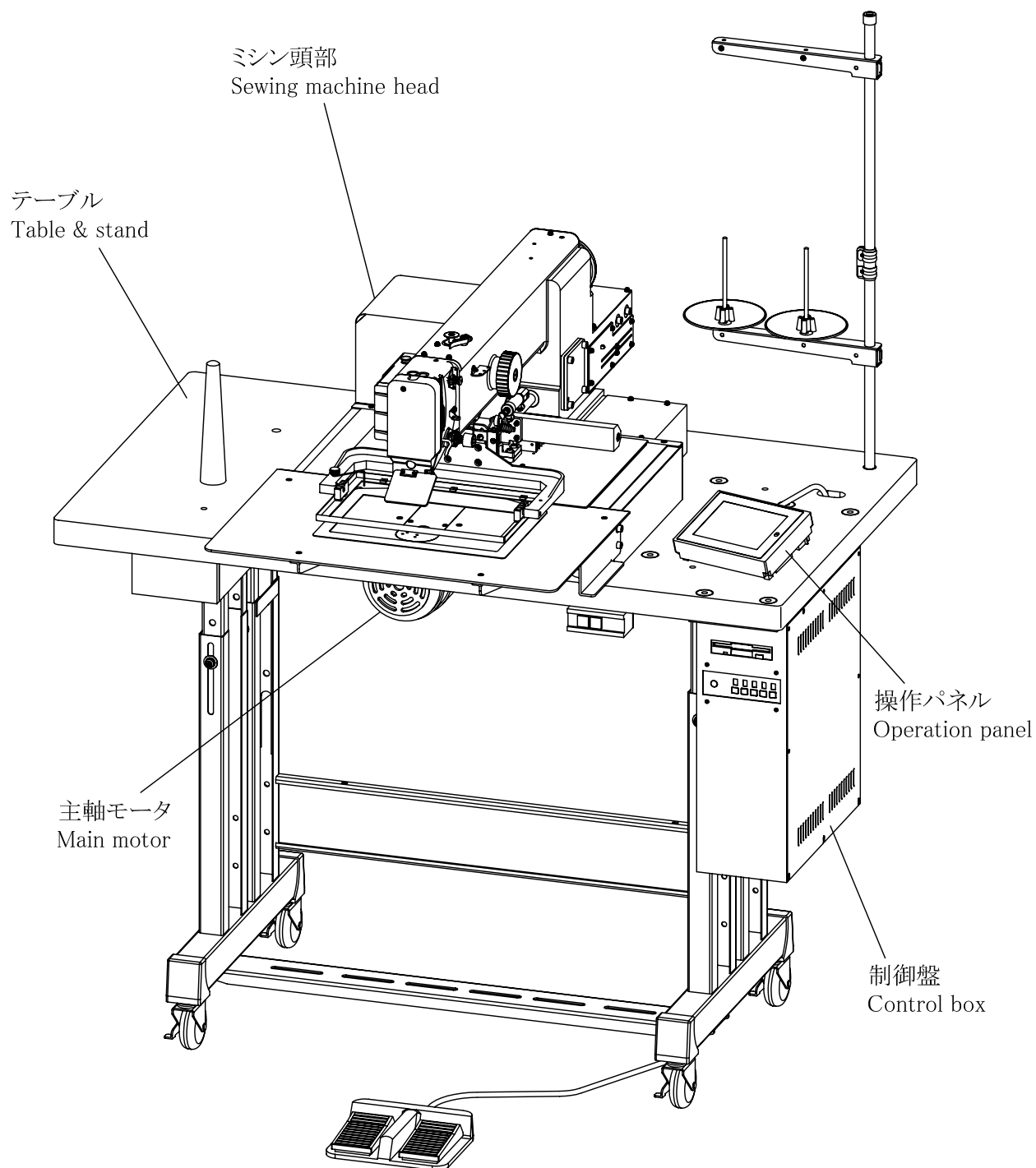

注1：モータ部分は三菱リミサーボX部品カタログを参照ください。

注2：Fig.No.の採番していない部品は単体で支給することは出来ません。Setにて支給いたします。

Remarks 1) Concerning about the motor parts please refer to the parts catalog of MITSUBISHI LIMISERVO X.

Remarks 2) The parts which Fig.No are not marked are not available individually. It can be supplied with the whole component.

B 本体関係(1)
 ARM BED & IT'S ACCESSORIES(1)

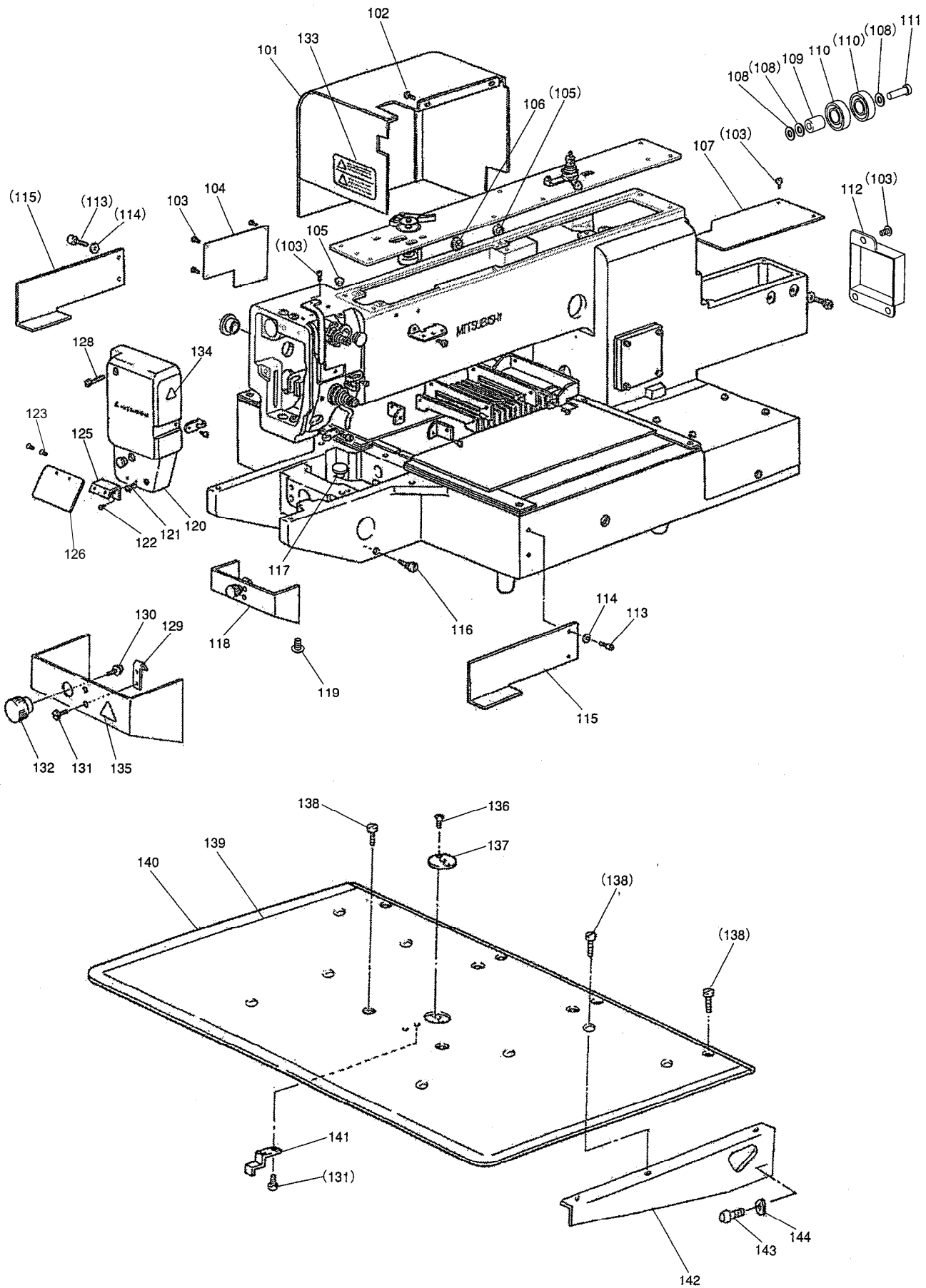

[B]本体関係(1)

ARM BED & IT'S ACCESSORIES(1)

Fig no.	変更 Mod.	部品コード Parts no.	品名	Description	数量 Amt. Req.
B 101		MB62E0849	モータカバー	Motor cover	1
B 102		M91071004	SW-MWプラマイナネジ M4X8	Screw M4X8	3
B 103		M91054004	SW-PWプラマイナネジ M4X8	Screw M4X8	11
B 104		ME10A0742	フタ	Cover	1
B 105		M91304080	セン	Rubber plug	3
B 106		M90883080	ゴムセン	Rubber plug	1
B 107		MB25A0742	フタ	Cover	1
B 108		M90823050	ミカキサガネ 8	Washer 8	3
B 109		MB60A0750	ブッシュ	Holder	1
B 110		MS10A1456	ベアリング	Bearing	2
B 111		M91803022	ロックアナツキホタンホルト M8X40	Bolt M8X40	1
B 112		ME25A0339	カバー	Cover	1
B 113		M96002017	セフティソケット M6X12	Bolt M6X12	4
B 114		M90631050	ミカキサガネ 6	Washer 6	4
B 115		MB61A0601	トリツケイタ	Holder	2
B 116		M91067004	SW-PWプラマイナネジ M5X10	Screw M5X10	2
B 117		M90573080	セン	Rubber plug	1
B 118		ME27A0339	シリンダーカバー	Cylinder cover	1
B 119		M90859004	SW-PWプラマイナネジ M3X6	Screw M3X6	4
B 120		ME20A0830	メンイタ	Face plate	1
B 121		M91055004	SW-PWプラマイナネジ M4X22	Screw M4X22	1
B 122		M91110002	ヒラネジ 11/64(40)X8	Screw 11/64(40)X8	2
B 123		M90806002	ヒラネジ 1/8(40)X6	Screw 1/8(44)X6	2
B 125		MB61A1601	アイガードトリツケイタ	Eye guard bracket	1
B 126		MS01A0160	アイガード	Eye guard	1
B 128		M91066004	SW-PWプラマイナネジ M4X25	Screw M4X25	1
B 129		M91058004	SW-PWプラマイナネジ M4X6	Screw M4X6	1
B 130		MS01A0361	カケガネ	Latch	1
B 131		M90906003	マルヒラネジ 9/64(40)X3.2	Screw 9/64(40)X3.2	4
B 132		MB61A0650	ナールノブ	Knurled knobs	1
B 133		MB61A0459	ケイコクシール	Warnig seal	1
B 134		MB61A1459	ケイコクシール	Warnig seal	1
B 135		MB61A2459	ケイコクシール	Warnig seal	1
B 136		M90605010	サラネジ 3/32(56)X2.8	Screw 3/32(56)X2.8	2
B 137		MS02A1101	ハリアナイタ	Needle plate	1
B 138		M90990002	ヒラネジ M4X8	Screw M4X8	12
B 139		MB61A0797	ホコフィルム	Film sheet	1
B 140		MB61A0470	スベリイタ	Slide plate	1
B 141		MS10A0192	イタバネ	Leaf spring	1
B 142		MB25A0426	ササエカナグ	Bracket	1
B 143		M95002017	セフティソケット M5X12	Bolt M5X12	6
B 144		M90511050	ミカキサガネ 5	Washer 5	6

C 本体関係(2)
 ARM BED & IT'S ACCESSORIES(2)

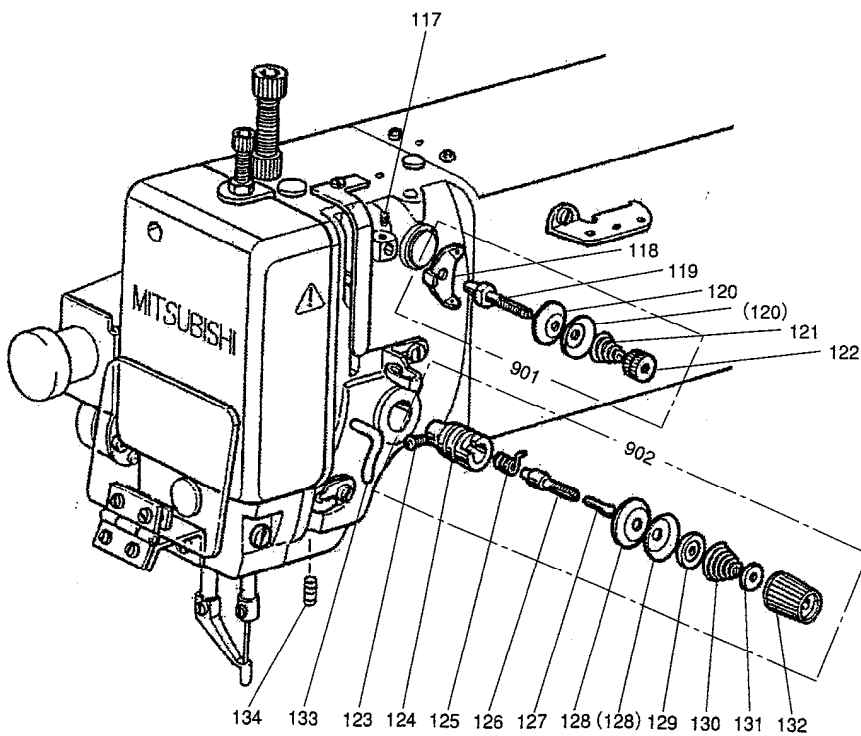
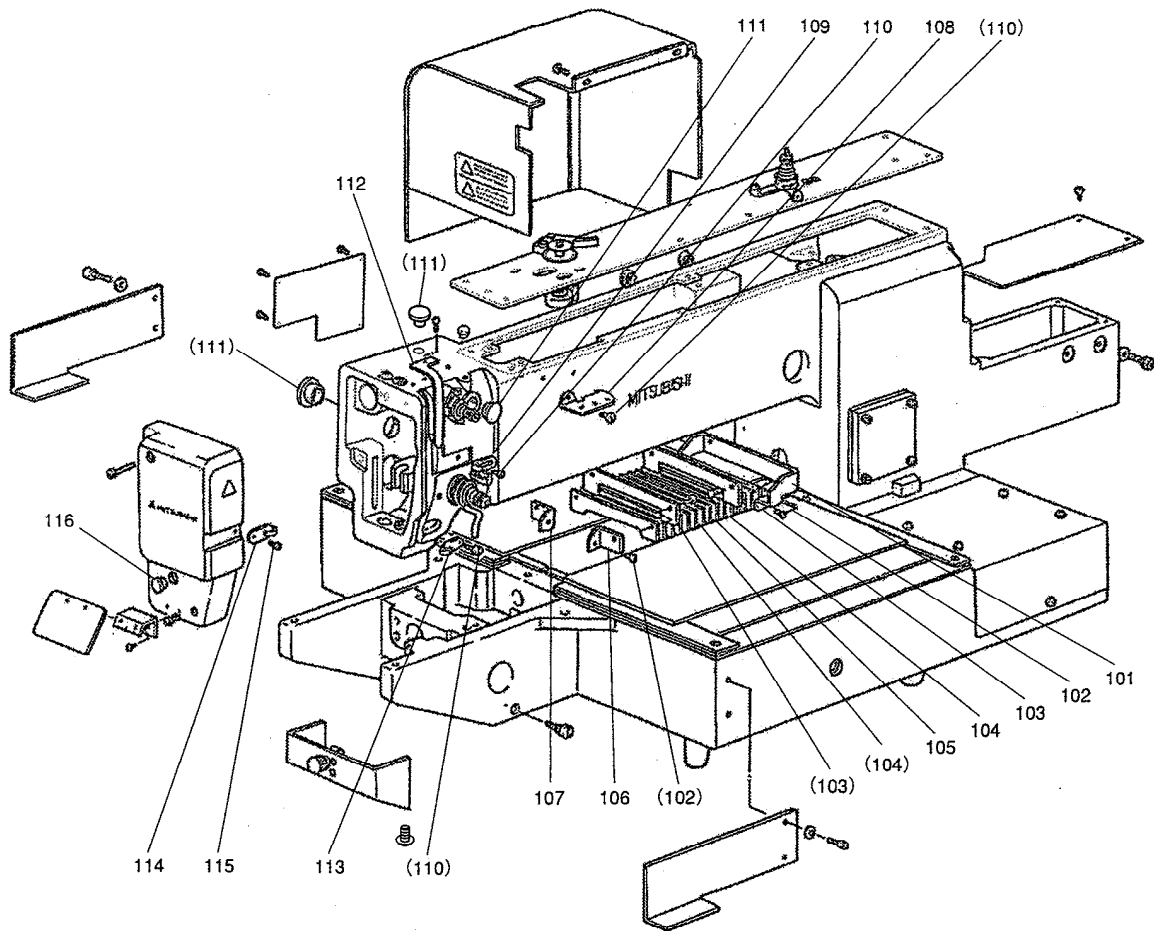

[C]本体関係(2)

ARM BED & IT'S ACCESSORIES(2)

Fig no.	変更 Mod.	部品コード Parts no.	部品名	Description	数量 Amt. Req.
C 101		MB25A1601	ジャハ ^ラ トリツケイタ	Shutter adapter	1
C 102		M91058004	SW-PW ^ラ マイナ ^ハ ネジ [〃] M4X6	Screw M4X6	4
C 103		MA20A0257	オサエイタ	Shutter holder	2
C 104		M90859004	SW-PW ^ラ マイナ ^ハ ネジ [〃] M3X6	Screw M3X6	4
C 105		MA20A0458	ジャハラ	Shutter	1
C 106		MB25A2601	ジャハ ^ラ トリツケイタ (ミキ)	Shutter adapter (R)	1
C 107		MB25A3601	ジャハ ^ラ トリツケイタ (ヒタ ^リ)	Shutter adapter (L)	1
C 108		MF36A1180	イトアンナイ	Thread guide	1
C 109		MG43A0181	イトアンナイ	Thread guide	1
C 110		M91011004	^ラ マイナ ^ハ ネジ [〃] M4X6	Screw M4X6	3
C 111		M91910080	ゴムセン	Rubber plug	3
C 112		MF03A0584	テンビンカバ [〃]	Thread take-up lever guard	1
C 113		MF10A0181	イトアンナイ	Thread guide	1
C 114		MG43A1181	イトアンナイ	Thread guide	1
C 115		M90909003	マルヒラネジ [〃] 9/64(40)X6	Screw 9/64(40)X6	2
C 116		M91182080	ゴムセン	Rubber plug	1
C 117		M91053020	ロツカクアナツキメネジ [〃] M4X6	Screw M4X6	2
C 118		MF00A0181	イトアンナイ	Thread guide	1
C 119		MF90A0553	チョウシホ ^ウ	Thread tension stud	1
C 120		MF10A1555	チョウシザ ^ラ	Thread tension discs	2
C 121		MF36A0245	エンスイハ ^ネ	Thread tension spring	1
C 122		M91101046	ツマミナツト	Thumb nut	1
C 123		M90901002	ヒラネジ [〃] 9/64(40)X4	Screw 9/64(40)X4	1
C 124		MF10A0709	ブツシュ	Thread tension regulator bushing	1
C 125		MF10A0187	イトトリハ ^ネ	Thread take-up spring	1
C 126		MF10A0553	チョウシホ ^ウ	Thread tension stud	1
C 127		M90204060	ピン	Thread tension releasing pin	1
C 128		MF10A0555	チョウシザ ^ラ	Thread tension discs	2
C 129		MM11A0556	チョウシザ ^ラ オサエ	Disc retaining plate	1
C 130		MN52A1245	エンスイハ ^ネ	Thread tension spring	1
C 131		MT60A0802	マワリド ^メ	Thumb nut revolution stopper	1
C 132		M91610046	ツマミナツト	Thumb nut	1
C 133		MF70A1180	イトアンナイ	Thread guide	1
C 134		M95004020	ロツカクアナツキメネジ [〃] M5X8	Screw M5X8	1
C 901		MF00E0550	チョウセツキクミタテ	Thread tension regulator assy	1
C 902		MA16E0210	チョウセツキクミタテ	Thread tension regulator assy	1

D 本体関係(3)
 ARM BED & IT'S ACCESSORIES(3)

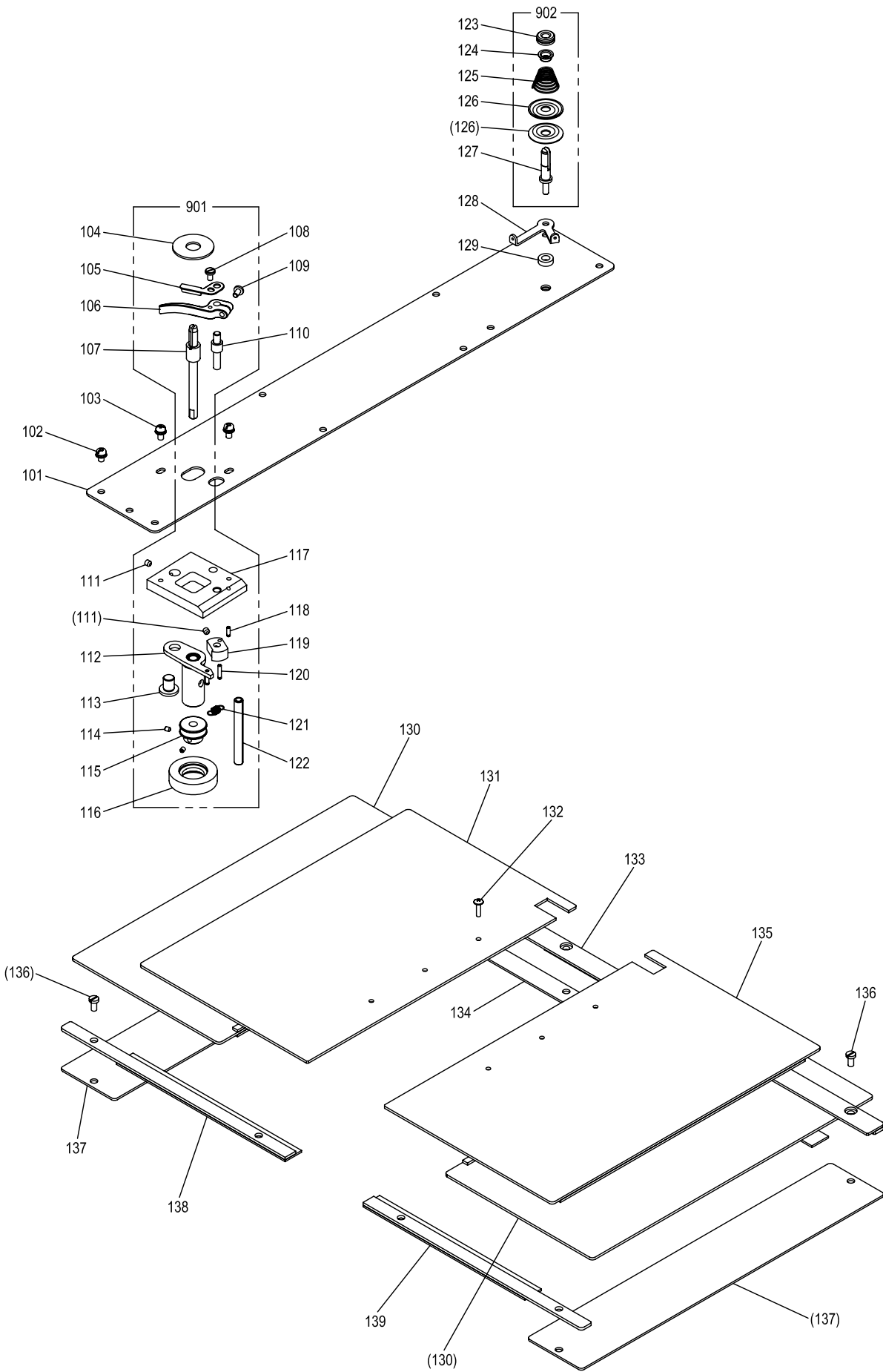

[D]本体関係(3)

ARM BED & IT'S ACCESSORIES(3)

Fig no.	変更 Mod.	部品コード Parts no.	品名	Description	数量 Amt. Req.
D 101		ME27A0600	トップカバー	Top cover	1
D 102		M91054004	SW-PWフライナベネジ M4X8	Screw M4X8	8
D 103		M91013004	SW-MWフライナベネジ M4X10	Screw M4X10	2
D 104		MA20A0476	スペーサ	Spacer	1
D 105		ME25A0551	チョウセツイタ	Adjuster plate	1
D 106		ME25A0950	レバー	Lever	1
D 107		MA16A0530	ダンツクシク D	Driven shaft	1
D 108		M90920002	ヒラネジ 9/64(40)X6.5	Screw 9/64(40)X6.5	1
D 109		M90939002	ヒラネジ 9/64(40)X11	Screw 9/64(40)X11	1
D 110		ME25A0530	ダンツクシク	Shaft	1
D 111		M91055020	ロツカクアナツキトメネジ M4X4	Screw M4X4	2
D 112		MB61E0750	レバークミタテ	Lever	1
D 113		M99006063	ピン	Pin	1
D 114		M91057020	ロツカクアナツキトメネジ M3X4	Screw M3X4	2
D 115		MA20A0194	イマキグルマ	Wheel	1
D 116		MS03A0417	ゴムワ	Tire	1
D 117		MB60A1601	トリツケイタ	Bracket	1
D 118		M91004067	ミゾツキピン BXガタ φ2.5X8	Pin φ2.5X8	1
D 119		MS14A0350	カム	Cam	1
D 120		M91005067	ミゾツキピン BXガタ φ2.5X12	Pin φ2.5X12	1
D 121		MS14A0572	ツルマキバネ	Spring	1
D 122		M90602064	スプリングピン φ6X40	Pin φ6X40	1
D 123		M91602046	ツマミナット	Thumb nut	1
D 124		MM11A0702	バネアンナイ	Spring guide	1
D 125		MM11A0245	エンスイバネ	Thread tension spring	1
D 126		MF10A0555	チョウシザラ	Thread tension discs	2
D 127		MS14A0553	チョウシホウ	Thread tension stud	1
D 128		MS14A1180	イアンナイ	Thread guide	1
D 129		MG75A1476	スペーサ	Spacer	1
D 130		MB25A2339	Xイトウカバークミタテ	X-movable plate assy	2
D 131		MB25B1339	Xカバーイタクミタテ (ヒタリ)	X-cover plate assy (L)	1
D 132		MB25A1339	Xカバーイタクミタテ (ミキ)	X-cover plate assy (R)	1
D 133		M90103036	Ptrラスネジ M3X12	Screw M3X12	6
D 134		MB25A0359	カバーガイドクミタテ (ウシロ)	Cover guide assy (rear)	1
D 135		MB25A0476	スペーサ	Spacer	1
D 136		M90990002	ヒラネジ M4X8	Screw M4X8	8
D 137		MB25A3339	X-Yカバー	X-Y cover	2
D 138		MB25B1476	スペーサクミタテ (ヒタリ)	Spacer assy (L)	1
D 139		MB25A1476	スペーサクミタテ (ミキ)	Spacer assy (R)	1
D 901		ME20E0190	イマキソウチクミタテ	Bobbin winder	1
D 902		MS14E0180	チョウセツキクミタテ	Thread tension Regulator assy	1

E 縫い機構(1)
SEWING MECHANISM(1)

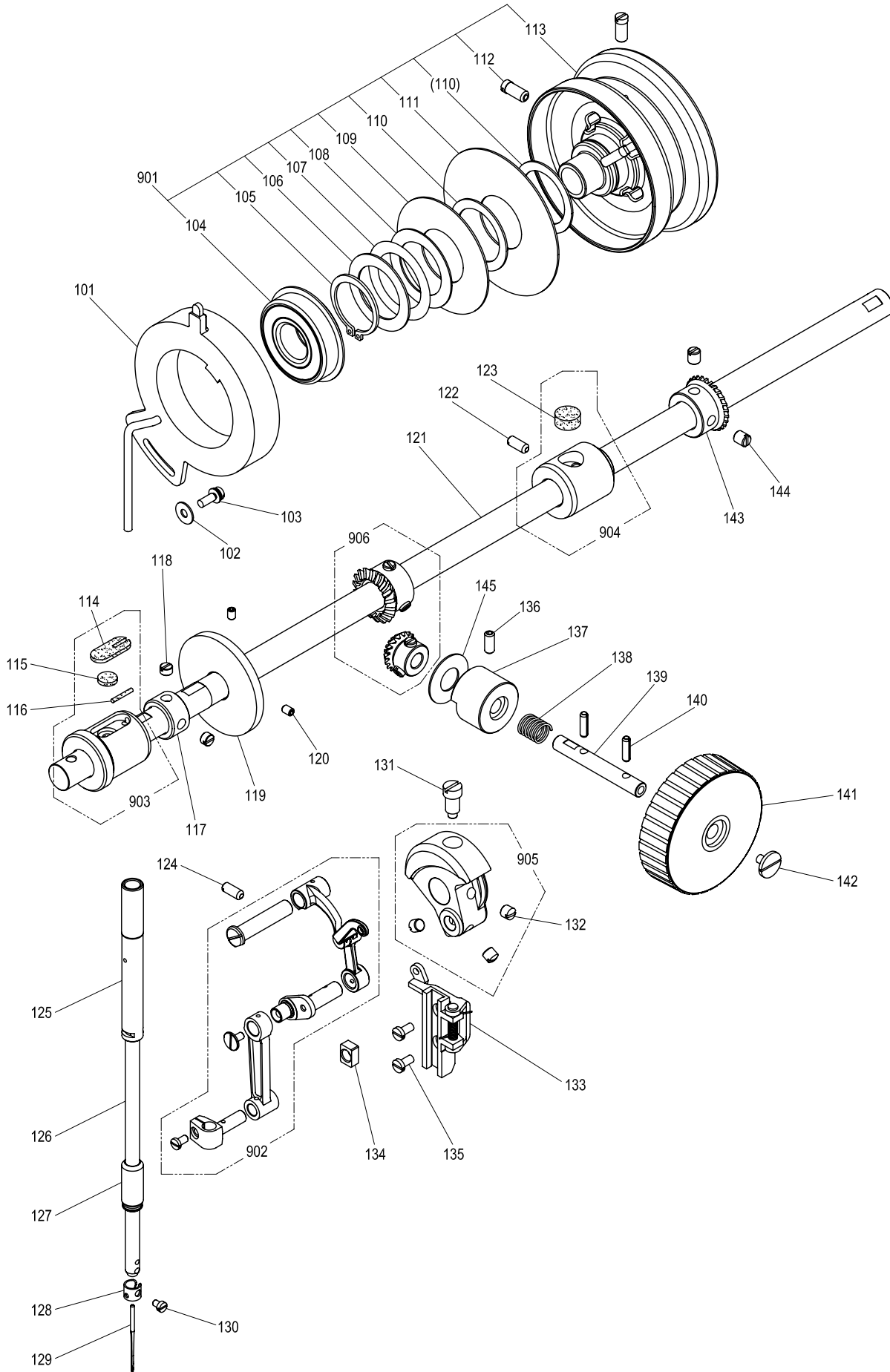

[E]縫い機構(1)

SEWING MECHANISM(1)

Fig no.	変更 Mod.	部品コード Parts no.	品名	Description	数量 Amt. Req.
E 101		ME20A0406	ウワジクセンシュツキ	Detector	1
E 102		M90421050	ザガネ 4	Washer 4	1
E 103		M91059004	SW-PWフライマインネジ M4X12	Screw M4X12	1
E 104		MN10A1456	ボールベアリング	Ball bearing	1
E 105		M90330065	Cガ外ワ 30	C-type retaining ring 30	1
E 106		M93001050	ザガネ	Washer	1
E 107		MF01A0259	ナミザガネ	Wave washer	1
E 108		MF01A1476	スぺーサ B	Spacer B	1
E 109		MN72A1694	ハンシャパン F20 (ウワイチ)	Command disk F20 (up)	1
E 110		MF01A0476	スぺーサ A	Spacer A	2
E 111		MB60A0694	ハンシャパン K10 (シタイチ)	Command disk K10 (down)	1
E 112		M91520002	ヒラネジ 15/64(28)X12	Screw 15/64(28)X12	2
E 113		MB60E0682	プーリ	Pulley	1
E 114		MG50A0740	フェルト	Felt	1
E 115		MS10A1740	フェルト	Felt	2
E 116		MV88A0740	フェルト	Felt	1
E 117		MF70A0352	カラー	Collar	1
E 118		M91602001	トメネジ 1/4(40)X4	Screw 1/4(40)X4	2
E 119		MS14A0682	イトマキプーリ	Pulley	1
E 120		M91053020	ロッカクアナツキトメネジ M4X6	Screw M4X6	2
E 121		MB25A0230	ウワジク	Drive shaft	1
E 122		M95003001	トメネジ M5X12	Screw M5X12	1
E 123		MB61A0740	フェルト	Felt	1
E 124		M91221001	トメネジ M5X12	Screw M5X12	1
E 125		MS10A0663	ハリホウメタル (ウエ)	Needle bar bushing (upper)	1
E 126		MA25A0660	ハリホウ	Needle bar	1
E 127		MF10A0664	ハリホウメタル (シタ)	Needle bar bushing (lower)	1
E 128		MG42A0181	イトアンナイ	Thread guide	1
E 129		MS02A0128	ミシンハリ DPX17#18	Needle DPX17#18	1
E 130		M90815002	ヒラネジ 1/8(44)X4.5	Screw 1/8(44)X4.5	1
E 131		M91802006	ヒラネジホウサキ 9/32(28)	Set screw 9/32(28)	1
E 132		M91606001	トメネジ 1/4(40)X6	Screw 1/4(40)X6	3
E 133		MG44E0662	ハリカイトクミタテ	Guide assy	1
E 134		MF10A0325	カクコマ	Square block	1
E 135		M90990002	ヒラネジ M4X8	Screw M4X8	2
E 136		M95006020	ロッカクアナツキトメネジ M5X12	Screw M5X12	1
E 137		ME25A1833	メタル	Bushing	1
E 138		MA35A2572	ツルマキハネ	Spring	1
E 139		ME25A0454	ジク	Shaft	1
E 140		M90406064	スプリングピン φ4X14	Pin φ4X14	2
E 141		ME25A0682	テマワシプーリ	Hand pulley	1
E 142		M91119002	ヒラネジ	Screw M4X8	1
E 143		MF40A0331	ウワジクカサハグルマ	Bevel gear for arm shaft	1
E 144		M91610001	トメネジ 1/4(40)X7	Screw 1/4(40)X7	2
E 145		ME25A0416	カンショウゴム	Rubber plate	1
E 901		MB60E1682	プーリクミタテ	Pulley assy	1
E 902		MS05E0580	テンビンハリクミタテ	Thread take-up lever assy	1
E 903		MS10A0232	ウワジクメタル(ヒタリ)クミ	Drive shaft bushing L assy	1
E 904		MB61E0234	ウワジクメタル(ナカ)クミ	Drive shaft bushing C assy	1
E 905		MF60A1383	クランククミ	Crank assy	1
E 906		ME25E0331	カサハグルマクミ	Bevel gear assy	1

F 縫い機構(2)
SEWING MECHANISM(2)

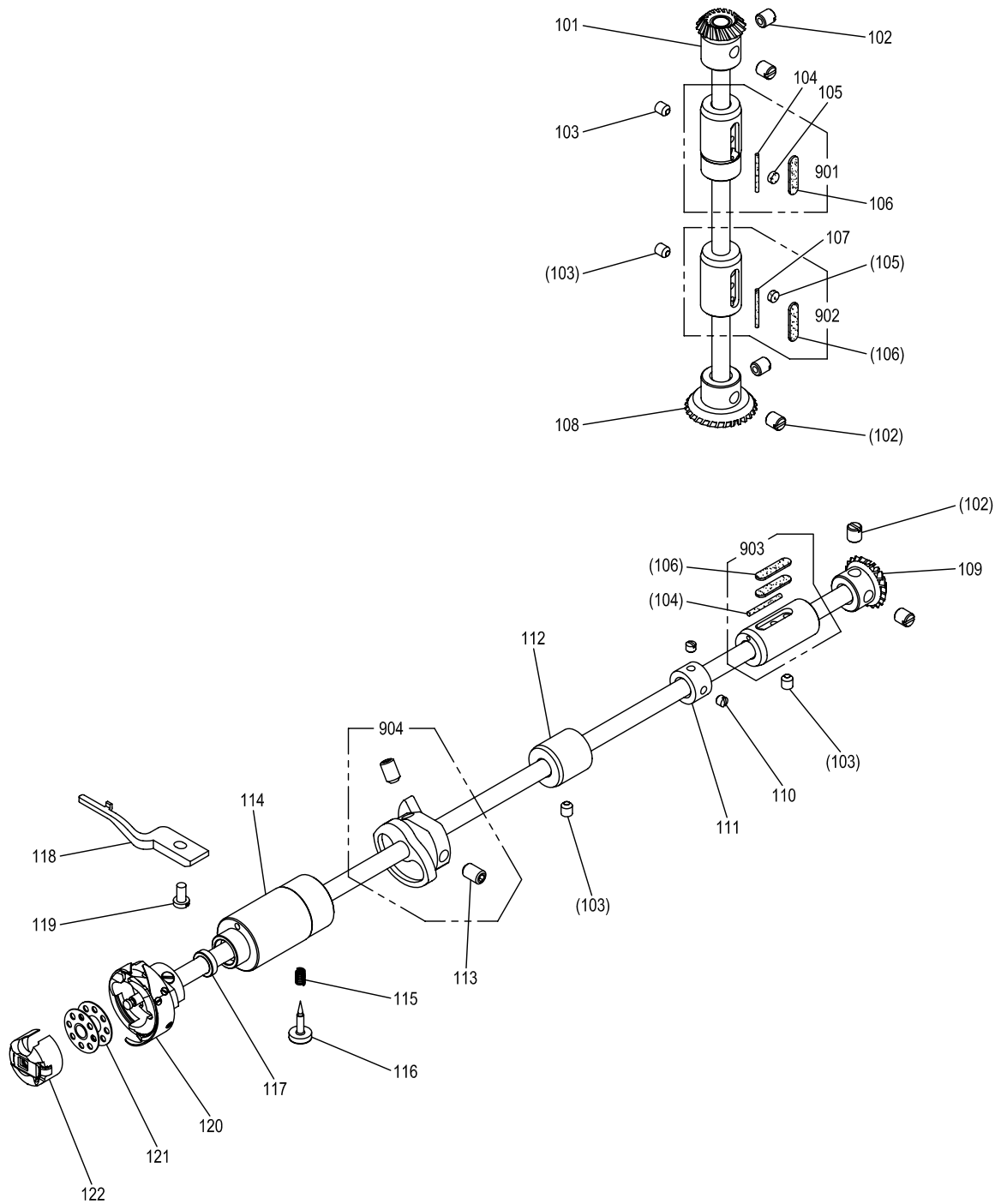

[F]縫い機構(2)

SEWING MECHANISM(2)

Fig no.	変更 Mod.	部品コード Parts no.	品名	Description	数量 Amt. Req.
F 101		MF40A0333	タテジカサハグルマ (ウエ)	Bevel gear for vertical shaft (upper)	1
F 102		M91610001	トメネジ 1/4(40)X7	Screw 1/4(40)X7	6
F 103		M95002020	ロッククアナツキトメネジ M5X6	Screw M5X6	4
F 104		MB61A0148	ヒモ	Felt	2
F 105		MS10A0740	フェルト	Felt	2
F 106		MF60A0740	フェルト	Felt	4
F 107		MN70E1148	ヒモ	Felt	1
F 108		MF10A0334	タテジカサハグルマ (シタ)	Bevel gear for vertical shaft (lower)	1
F 109		MF10A0332	シタジカサハグルマ	Bevel gear for hook shaft	1
F 110		M91106001	トメネジ 11/64(40)X3.7	Screw 11/64(40)X3.7	2
F 111		MF01E0352	カラー	Collar	1
F 112		MF00A0453	シタジクメタル (ナカ)	Hook shaft bushing (M)	1
F 113		M91602020	ロッククアナツキトメネジ 1/4(40)X10	Screw 1/4(40)X10	2
F 114		MS10A0451	シタジクメタル (ヒタリ)	Hook shaft bushing (L)	1
F 115		MG30A0700	ツルマキハネ	Spring	1
F 116		M90801006	ヒラネジホウサキ M3X9.5	Screw M3X9.5	1
F 117		M90800086	オイルシール	Oil seal	1
F 118		MF20A0229	ウチカマドメ	Hook positioner	1
F 119		M90990002	ヒラネジ M4X8	Screw M4X8	1
F 120		ME20A0120	カマクミタテ	Hook complete	1
F 121		MF25B0123	ホビン	Bobbin	1
F 122		MG44E0125	ホビンケース	Bobbin case	1
F 901		MB61E0521	タテジクメタル(ウエ)クミタテ	Vertical shaft bushing (upper) assy	1
F 902		MB25E0522	タテジクメタル(シタ)クミタテ	Vertical shaft bushing (lower) assy	1
F 903		MB61E0452	シタジクメタル(ミキ)クミタテ	Hook shaft bushing (R) assy	1
F 904		MF01E0350	イトキリカム	Thread trimmer cam	1

G 中押え機構
PRESSER BAR LIFTING MECHANISM

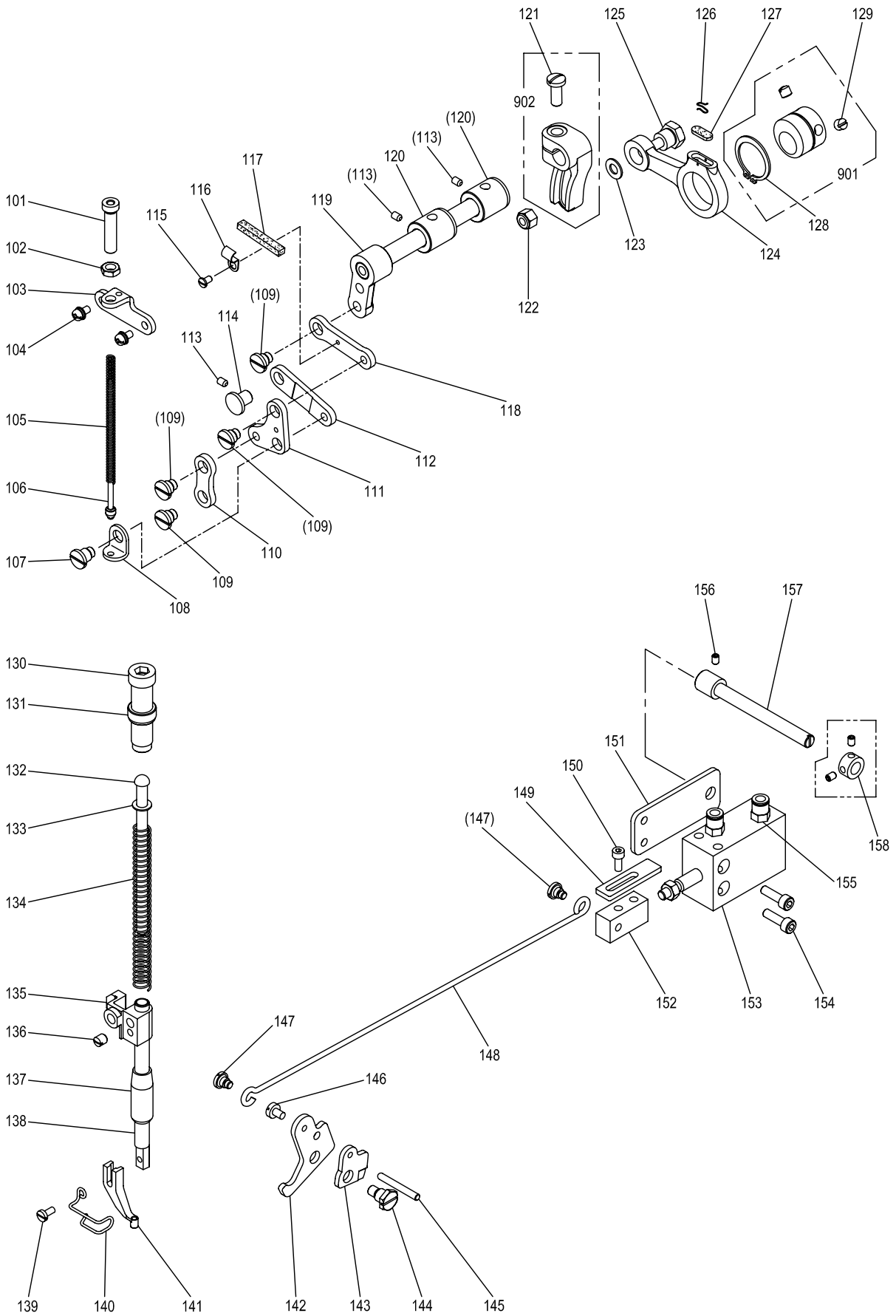

[G]中押え機構

PRESSER BAR LIFTING MECHANISM

Fig no.	変更 Mod.	部品コード Parts no.	品名	Description	数量 Amt. Req.
G 101		M91801035	ツマミネジ 9/32(28)X35	Thumb screw 9/32(28)X35	1
G 102		M91802045	ナット 9/32(28)	Nut 9/32(28)	1
G 103		ME10A0261	オサエチヨウセツダイ	Bracket	1
G 104		M91056004	SW-PWアラマイナベネジ M4X10	Screw M4X10	2
G 105		ME10A0572	ツルマキハネ	Spring	1
G 106		MS03A6154	アンナイガネ	Spring guide bar	1
G 107		M91689015	ヒラネジダンツキ 1/4(40)	Screw 1/4(40)	1
G 108		ME20A0426	オサエイタサエ	Supporter	1
G 109		M91688015	ヒラネジダンツキ 1/4(40)	Screw 1/4(40)	4
G 110		ME10A6910	リンク	Link	1
G 111		ME10A0763	ベルクランク	Bell crank	1
G 112		ME10A7910	リンク	Link	1
G 113		M91058020	ロツカクアナツキトメネジ M4X10	Screw M4X10	3
G 114		M99006063	ツハツキシク	Pin	1
G 115		M90909003	マルヒラネジ 9/64(40)X6	Screw 9/64(40)X6	1
G 116		MN70A1780	ホルダ	Holder	1
G 117		MG30A0740	フェルト	Felt	1
G 118		ME10A1956	レンセツカン	Link	1
G 119		MS02E0460	ウデクミタテ	Arm shaft assy	1
G 120		MG30A0833	メタル	Bushing	2
G 121		M91603003	マルヒラネジ 1/4(40)X16	Screw 1/4(40)X16	1
G 122		M91572045	U ナット 6X0.75	U-nut 6X0.75	1
G 123		M90631050	サガネ 6	Washer 6	1
G 124		ME10A0956	レンセツカン	Crank rod	1
G 125		M91551015	ホルトダンツキ M6	Bolt M6	1
G 126		MF60A0700	センサイクハネ	Holder	1
G 127		MG30B0740	フェルト	Felt	1
G 128		M90325065	Cガ外メワ 25	C-type retaining ring 25	1
G 129		M91606001	トメネジ 1/4(40)X6	Screw 1/4(40)X6	2
G 130		M93220035	ツマミネジ 1/2(28)X43	Thumb screw 1/2(28)X43	1
G 131		M93202047	ナット 1/2(28)	Nut 1/2(28)	1
G 132		MF20A0703	アンナイホウ	Presser bar guide	1
G 133		M90632050	コサガネ 6	Washer 6	1
G 134		MS02A0259	ツルマキハネ	Spring	1
G 135		MG75A0265	オサエホウダキ	Presser bar holder	1
G 136		M91506001	トメネジ 15/64(28)X6	Screw 15/64(28)X6	1
G 137		MF10A0267	オサエホウメタル	Bushing	1
G 138		MS03A0262	オサエホウ	Presser bar	1
G 139		M90922002	ヒラネジ 9/64(40)X8	Screw 9/64(40)X8	1
G 140		MB62A0626	ニードルガード	Needle guard	1
G 141		MV30A0256	オサエ φ3	Presser foot φ3	1
G 142		ME10A1252	オサエアケレバ	Lifting lever	1
G 143		MF70A0350	イトユルメカム	Plate cam	1
G 144		M91504031	ホルト 15/64(28)	Bolt 15/64(28)	1
G 145		M90423060	イトユルピン	Pin	1
G 146		M91131002	ヒラネジ 11/64(40)X6.5	Screw 11/64(40)X6.5	1
G 147		M91219015	ヒラネジダンツキ 3/16(28)	Screw 3/16(28)	2
G 148		ME27A0738	ヒキホウ	Link	1
G 149		ME25A0477	ストッパ	Stopper	1
G 150		M95003017	セフティソケット M5X8	Bolt M5X8	2
G 151		ME25A0601	トリツケイタ	Adapter	1
G 152		ME25A0571	ジョイント	Joint	1
G 153		ME25A0434	エアシリンダ	Air cylinder	1
G 154		M95006017	セフティソケット M5X22	Bolt M5X22	2
G 155		ME40A0571	ワンタッチツギテ	Connector	1
G 156		M95004020	ロツカクアナツキトメネジ M5X8	Screw M5X8	1
G 157		ME20A0530	ダンツキシク	Shaft	1
G 158		ME20A0352	カラー	Collar	1
G 901		MG30A0760	ヘンシンリンクミタテ	Eccentric cam assy	1
G 902		MS02A0463	ウデ (ミキ)	Arm (right)	1

H 糸切り機構
 THREAD TRIMMING MECHANISM

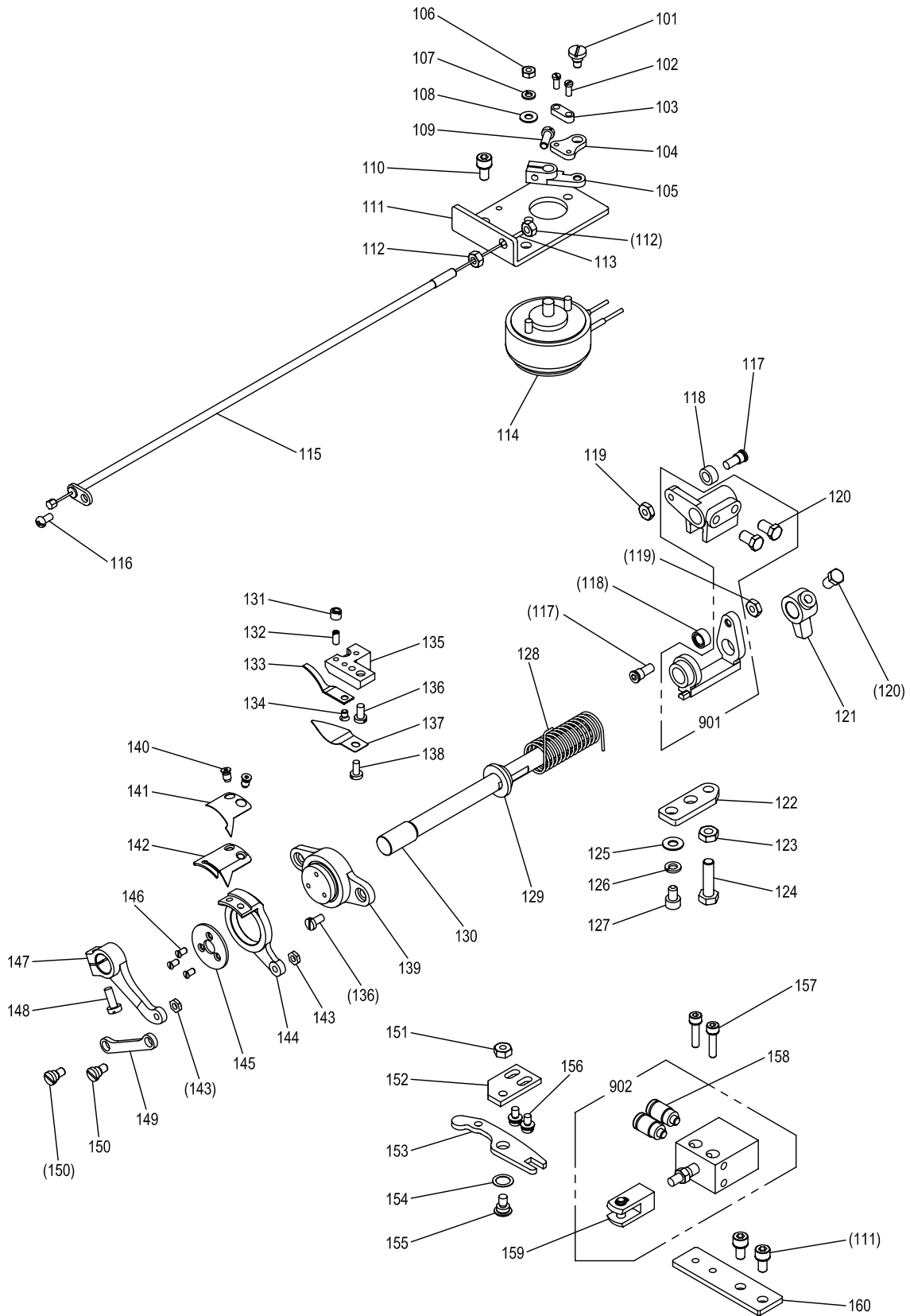

[H]糸切り機構

THREAD TRIMMING MECHANISM

Fig no.	変更 Mod.	部品コード Parts no.	品名	Description	数量 Amt. Req.
H 101		M91127015	ヒラネジ ^ダ ツキ 11/64(40)·····	Screw 11/64(40)·····	1
H 102		M90802002	ヒラネジ 1/8(44)X7·····	Screw 1/8(44)X7·····	2
H 103		MF36A0750	ホルダ·····	Holder·····	1
H 104		MF90A0361	カケガネ·····	Bracket·····	1
H 105		MS07A0228	ウデ·····	Crank·····	1
H 106		M91007045	ナット M4·····	Nut M4·····	2
H 107		M90424053	ハネサガネ 4·····	Spring washer 4·····	2
H 108		M90421050	サガネ 4·····	Washer 4·····	2
H 109		M91112002	ヒラネジ 11/64(40)X12·····	Screw 11/64(40)X12·····	1
H 110		M95005017	セフティソケット M5X10·····	Bolt M5X10·····	4
H 111		MA20A0603	ソレノイドトリツケイタ·····	Solenoid bracket·····	1
H 112		M91382045	ナット M5·····	Nut M5·····	2
H 113		MN60A0750	ブッシュ·····	Pipe·····	1
H 114		ME27E0519	イトユルメソレノイド·····	Solenoid (thread release)·····	1
H 115		ME27E0746	フレキシブルワイヤ クミ·····	Flexible wire assy·····	1
H 116		M91069004	プ ^ラ マイナ ^ハ ネジ M4X8·····	Screw M4X8·····	1
H 117		MF00A0412	コロンク·····	Roller stud·····	2
H 118		MF00A0411	コロ·····	Roller·····	2
H 119		M91201045	ナット 3/16(28)·····	Nut 3/16(28)·····	2
H 120		M91501022	ホルト 15/64(28)X10·····	Bolt 15/64(28)X10·····	3
H 121		ME20E0477	ストッパ·····	Stopper·····	1
H 122		MF00A1477	ストッパ ^イ タ·····	Stopper plate·····	1
H 123		M91502045	ナット 15/64(28)·····	Nut 15/64(28)·····	1
H 124		M91512022	ホルト 15/64(28)X20·····	Bolt 15/64(28)X20·····	1
H 125		M90552050	サガネ 5·····	Washer 5·····	2
H 126		M90501053	ハネサガネ 5·····	Spring washer 5·····	2
H 127		M95009021	ロツカクアナツキホルト M5X8·····	Bolt M5X8·····	2
H 128		MA25A0572	ツルマキハネ·····	Spring·····	1
H 129		MF00A0750	ブッシュ·····	Bushing·····	1
H 130		MA25A0891	メスユウト ^ウ シク·····	Knife driving shaft·····	1
H 131		M91110045	ナット 9/64(40)·····	Nut 9/64(40)·····	1
H 132		M90913001	トメネジ 9/64(40)X8.5·····	Screw 9/64(40)X8.5·····	1
H 133		MS10A0838	コテイメス·····	Fixed blade·····	1
H 134		M90907010	サラネジ 9/64(40)X5·····	Screw 9/64(40)X5·····	1
H 135		MF00A1603	トリツケ ^ダ イ·····	Bracket for fixed blade·····	1
H 136		M90990002	ヒラネジ M4X8·····	Screw M4X8·····	3
H 137		MS07A0180	イトアンナイ·····	Thread guide·····	1
H 138		M90921002	ヒラネジ 9/64(40)X8·····	Screw 9/64(40)X8·····	1
H 139		MF00A1527	ダイサ·····	Knife holding bracket saddle·····	1
H 140		M91151010	サラネジ 11/64(40)X7·····	Screw 11/64(40)X7·····	2
H 141		MF02A0834	メス (ヒ ^ダ リ)·····	Movable knife (left)·····	1
H 142		MS07A0782	ホコ ^イ タ·····	Guard plate·····	1
H 143		M91107045	ナット 11/64(40)·····	Nut 11/64(40)·····	2
H 144		MS07A0836	メスタ ^イ (ヒ ^ダ リ)·····	Knife base (left)·····	1
H 145		M94006052	サガネ·····	Washer·····	1
H 146		M90803010	サラネジ 1/8(44)X6·····	Screw 1/8(44)X6·····	3
H 147		MF00A0392	ク ^ト ウ ^イ タ·····	Knife driving crank·····	1
H 148		M91117002	マルヒラネジ 11/64(40)X13·····	Screw 11/64(40)X13·····	1
H 149		MF00A8910	リンク·····	Link·····	1
H 150		M91111015	ヒラネジ ^ダ ツキ 11/64(40)·····	Screw 11/64(40)·····	2
H 151		M91202045	ナット 3/16(28)·····	Nut 3/16(28)·····	1
H 152		MS07A1603	トリツケ ^イ タ·····	Adapter·····	1
H 153		MF00A0391	ク ^ト ウ ^イ タ·····	Flexible·····	1
H 154		M90834050	シム·····	Washer·····	1
H 155		M91212015	ヒラネジ ^ダ ツキ 3/16(28)·····	Screw 3/16(28)·····	1
H 156		M91054004	SW-PW ^ラ マイナ ^ハ ネジ M4X8·····	Screw M4X8·····	2
H 157		M94018017	セフティソケット M4X18·····	Bolt M4X18·····	2
H 158		MA20A5571	ワ ^ン タ ^ツ チ ^ツ キ ^テ ·····	Connector·····	2
H 159		MA16A0621	ナツツル·····	Knuckle·····	1
H 160		MA25A0601	シリンダ ^ト リツケ ^イ タ·····	Cylinder bracket·····	1
H 901		MB61E0351	カムツイジ ^ユ ウ ^ウ テ ^ク ミ ^タ テ·····	Cam follower crank assy·····	1
H 902		MB61E0434	エアシリンダ ^ク ミ ^タ テ·····	Air sylander assy·····	1

J X-Yテーブル機構
X-Y TABLE MECHANISM

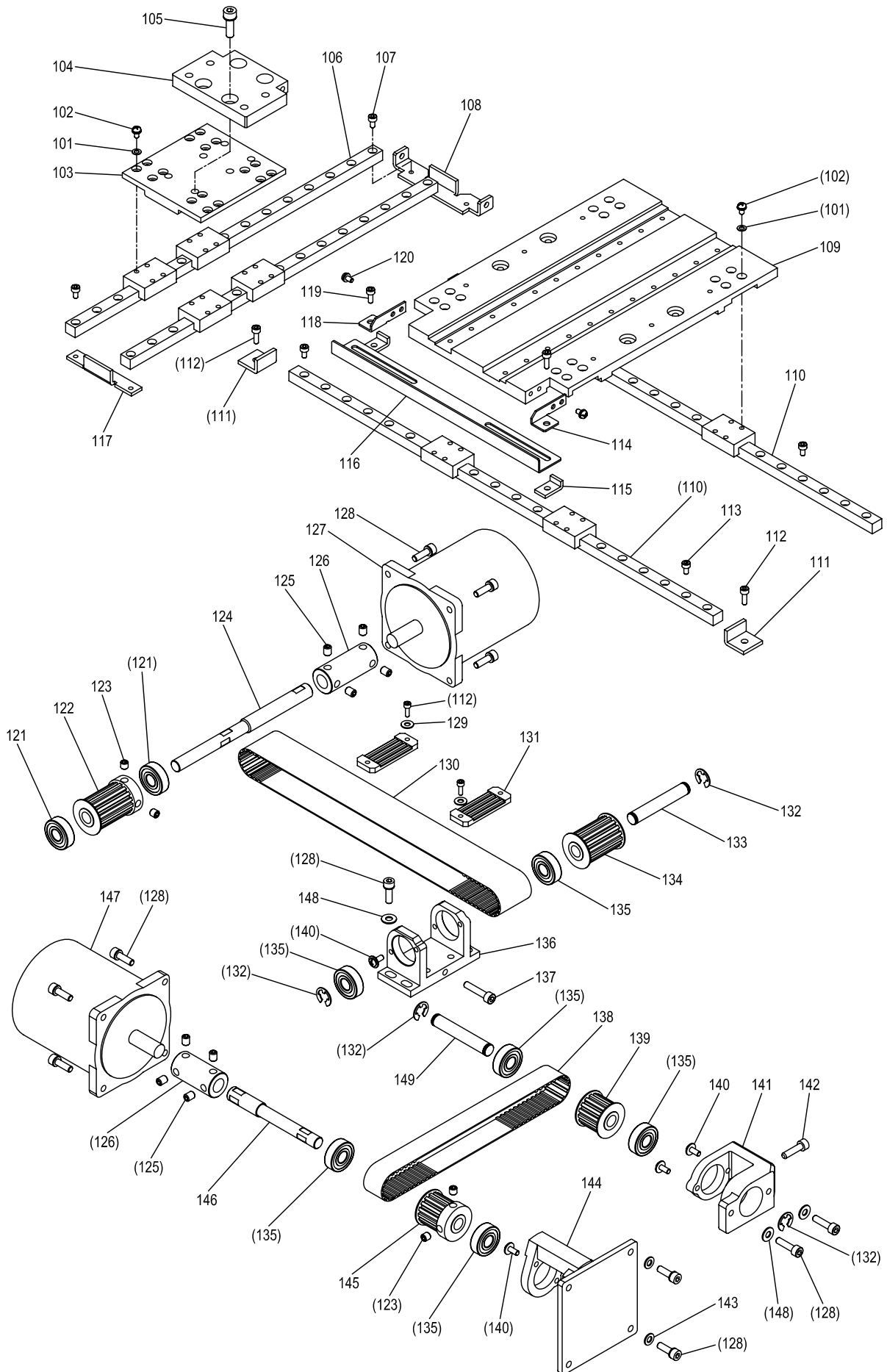

[J]X-Yテーブル機構
X-Y TABLE MECHANISM

Fig no.	変更 Mod.	部品コード Parts no.	品名	Description	数量 Amt. Req.
J 101		M90317050	ザガネ 3	Washer 3	32
J 102		M90814004	プラマイナベネジ M3X5.2	Screw M3X5.2	32
J 103		MB62E0957	Yジクイトウレース	Y-movable race	1
J 104		MB25A4601	オサエタイトリツケイタ	Clamp adapter	1
J 105		M95002017	セフティソケット M5X12	Bolt M5X12	4
J 106		MA20A5920	リニアウェイ (Y)	Y-liner way	2
J 107		M93004021	ロッカクアナツキホルト M3X5	Bolt M3X5	26
J 108		MB25A0477	Yジクストッパ	Y-stopper	1
J 109		MB62E1957	Xジクイトウレース	X-movable race	1
J 110		MA20A4920	リニアウェイ (X)	X-linear way	2
J 111		MB62E2477	Xジクストッパ	X-stopper	2
J 112		M94001017	セフティソケット M4X10	Bolt M4X10	6
J 113		M95013021	ロッカクアナツキホルト M3X10	Bolt M3X10	24
J 114		MB60A1429	ケンシュツハンササエ (R)	Bracket (right)	1
J 115		MB60A2601	ケンシュツハンソトリツケイタ	Bracket	2
J 116		MB62A2407	Xジクケンシュツハン	Detector plate X	1
J 117		MB25A1477	Yジクストッパ (マエ)	Y-stopper (front)	1
J 118		MB60A0429	ケンシュツハンササエ (L)	Bracket (left)	1
J 119		M94008017	セフティソケット M4X6	Bolt M4X6	2
J 120		M90816004	SW-PWプラマイナベネジ M3X8	Screw M3X8	4
J 121		MB62A0456	ベアリング 6000ZZNR	Bearing	2
J 122		MB45A0767	ベルトグルマ	Cog pulley	1
J 123		M96001001	ロッカクアナツキメネジ M6X8	Screw M6X8	4
J 124		MB25A0390	Xクトウジク	X-drive shaft	1
J 125		MB61A0571	ジクツギテ	Coupling	2
J 126		M96002001	ロッカクアナツキメネジ M6X6	Screw M6X6	8
J 127		M95044095	ステッピングモータクミタテ (X)	Motor complete (X)	1
J 128		M95004017	セフティソケット M5X16	Bolt M5X16	18
J 129		M90421050	ザガネ 4	Washer 4	4
J 130		MB62A0523	ハダカベルト (Xジク)	Cog belt (X)	1
J 131		MA35A1781	ベルトオサエ (X)	Belt clasper (X)	2
J 132		M90604065	Eカタメワ 8	E-type retaining ring 8	4
J 133		MA21P0454	ジク	Shaft	1
J 134		MB62A0767	ベルトグルマ	Cog pulley	1
J 135		MS02A2456	シールドボールベアリング	Ball bearing	6
J 136		MA35A6758	ブラケット	Bracket	1
J 137		M95015021	ロッカクアナツキホルト M5X20	Bolt M5X20	1
J 138		MB62A1523	ハカタベルト (Yジク)	Cog belt (Y)	1
J 139		MB61A0767	ベルトグルマ	Cog pulley	1
J 140		M91071004	SW-MWプラマイナベネジ M4X8	Screw M4X8	8
J 141		MB61A0758	ブラケット	Bracket	1
J 142		M95011021	ロッカクアナツキホルト M5X25	Bolt M5X25	1
J 143		M90512050	ザガネ 5	Washer 5	4
J 144		MB61A1758	ブラケット	Bracket	1
J 145		MB61A2767	ベルトグルマ	Cog pulley	1
J 146		MB61A1454	Yクトウジク	Y-drive shaft	1
J 147		M95043095	ステッピングモータクミタテ (Y)	Motor complete (Y)	1
J 148		M90511050	ザガネ 5	Washer 5	6
J 149		MS02A1454	ジク	Shaft	1

K 外押え機構(1)
WORK HOLDER MECHANISM(1)

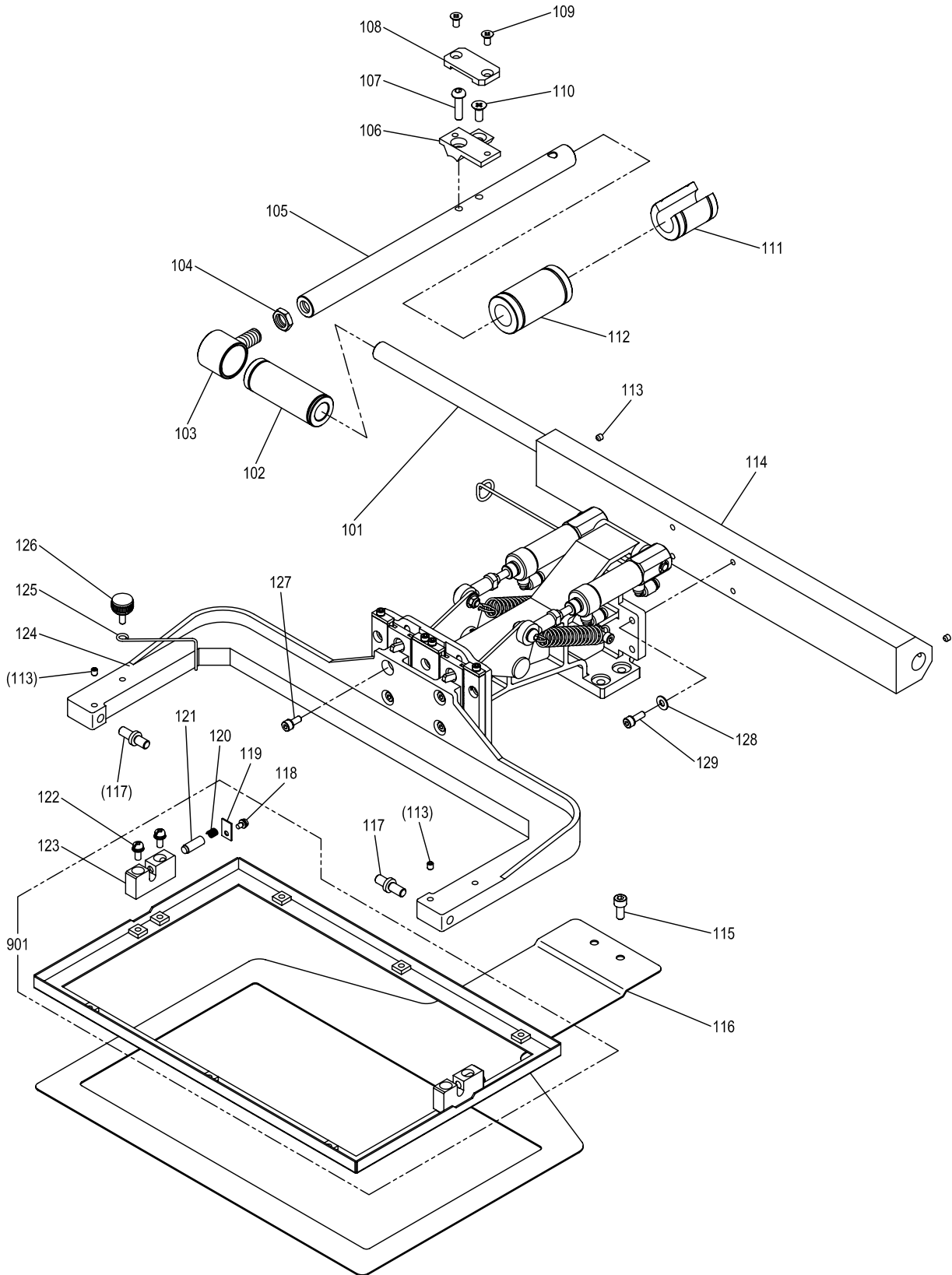

[K]外押え機構(1)

WORK HOLDER MECHANISM(1)

Fig no.	変更 Mod.	部品コード Parts no.	品名	Description	数量 Amt. Req.
K 101		MB62A2454	ジク	Shaft	1
K 102		MB62A0921	リニアブッシュ	Bearing	1
K 103		ME25A0692	ジクウケハウジング	Bearing housing	1
K 104		M92514045	ロックナット M10	Nut M10	1
K 105		ME27A0390	Yクトウジク	Y-drive shaft	1
K 106		ME25A0781	Yベルトダイ	Y-belt holder	1
K 107		M95031021	ロックアナツキボルト M5X12	Bolt M5X12	1
K 108		MS02A0778	ベルトオサエ	Belt clasper	1
K 109		M90448037	Pサラネジ M4X12	Screw M4X12	2
K 110		M90505037	Pサラネジ M5X12	Screw M5X12	1
K 111		ME25A0921	リニアブッシュ LM-16UU-OP	Bearing LM-16UU-OP	1
K 112		MB62A2921	リニアブッシュ N-16VUU	Bearing N-16VUU	1
K 113		M91053020	ロックアナツキメネジ M4X6	Screw M4X6	4
K 114		MB62A0455	ジクササエ	Shaft holder	1
K 115		M99002022	8Tロックホルト サラハネツキ M5X10	Bolt M5X10	2
K 116		MB25A0272	シタオサエイタ	Feed plate	1
K 117		ME40A0454	オサエジク	Clamp stud	2
K 118		M90859004	SW-PWプライネジ M3X6	Screw M3X6	2
K 119		MS02B0257	オサエイタ	Holder plate	2
K 120		MS13A0572	ツルマキハネ	Coil spring	2
K 121		M90611060	ピン	Pin	2
K 122		M91081004	SW-PWプライネジ M4X18	Screw M4X18	4
K 123		MB25B1426	ササエ	Support	2
K 124		MB62A0228	オサエウデ	Clamp adapter	1
K 125		ME27A0477	ストッパ	Stopper	1
K 126		MA20A0650	ナールノブ	Knurled knob	1
K 127		M95005017	セフティソケット M5X10	Bolt M5X10	4
K 128		M90421050	ワッシャ 4	Washer 4	4
K 129		M94006017	セフティソケット M4X16	Bolt M4X16	4
K 901		MB25E0105	ソトオサエクミタテ	Clamp frame assy	1

L 外押え機構(2)
WORK HOLDER MECHANISM(2)

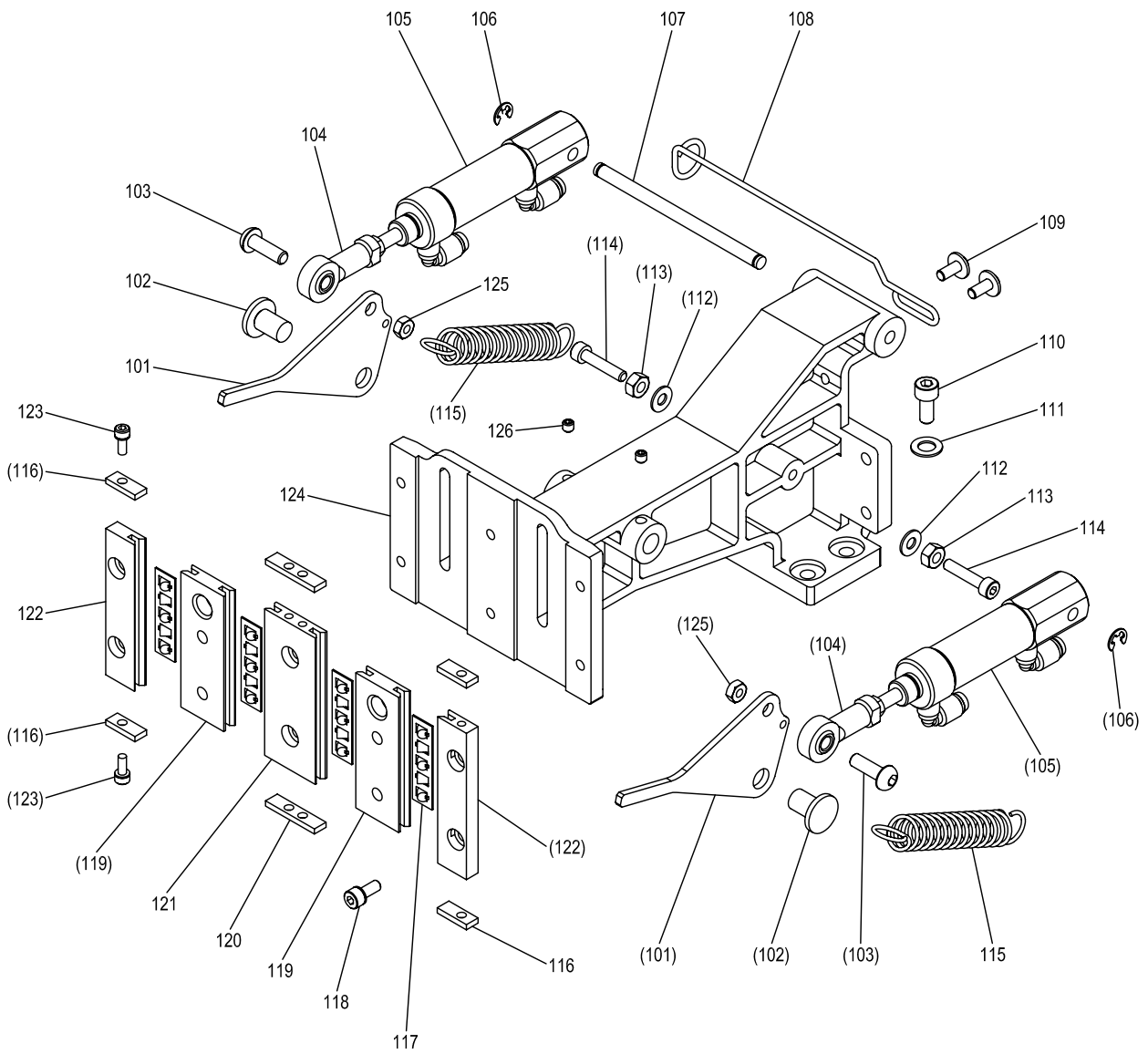

[L]外押え機構(2)

WORK HOLDER MECHANISM(2)

Fig no.	変更 Mod.	部品コード Parts no.	品名	Description	数量 Amt. Req.
L 101		MB62A0950	オサエレバー	Pushing lever	2
L 102		MB61A3454	ツハツキシク	Shaft	2
L 103		M95037021	ロックアナツキボルト M5X16	Bolt M5X16	2
L 104		MN55A0975	ロッドエンド	Connecting link	2
L 105		MB62A1434	エアシリンダ (ワンタッチツキテツキ)	Air cylinder (with quick joint)	2
L 106		M90504065	Eタイプメワ 4	E-type retaining ring 5	2
L 107		M90532060	ピン	Pin	1
L 108		MB62A0707	ハンガー	Hanger	1
L 109		M91013004	SW-MWプラマイナヘネジ M4X10	Screw M4X10	2
L 110		M95001017	セフティソケット M5X20	Bolt M5X20	4
L 111		M90511050	ワッシャ 5	Washer 5	4
L 112		M90421050	ワッシャ 4	Washer 4	2
L 113		M91007045	ナット M4	Nut M4	2
L 114		M94015021	ロックアナツキボルト M4X20	Screw M4X20	2
L 115		MB62A0572	ツルマキハネ	Spring	2
L 116		MB61A1477	ストッパ	Stopper	4
L 117		M94008070	ローラリテーナ	Slide bearing	4
L 118		M94001017	セフティソケット M4X10	Bolt M4X10	6
L 119		MB62A1957	イトウレース	Movable race	2
L 120		MA22A0477	ストッパ	Stopper	2
L 121		MA22A2957	コテイレース	Fixed race	1
L 122		MB62A0957	コテイレース	Fixed race	2
L 123		M94012017	セフティソケット M3X8	Bolt M3X8	8
L 124		MB62A0263	オサエタイ	Clamp bracket	1
L 125		M91382045	ナット M5	Nut M5	2
L 126		M91055020	ロックアナツキメネジ M4X4	Screw M4X4	2

M ワイパー機構
WIPER MECHANISM

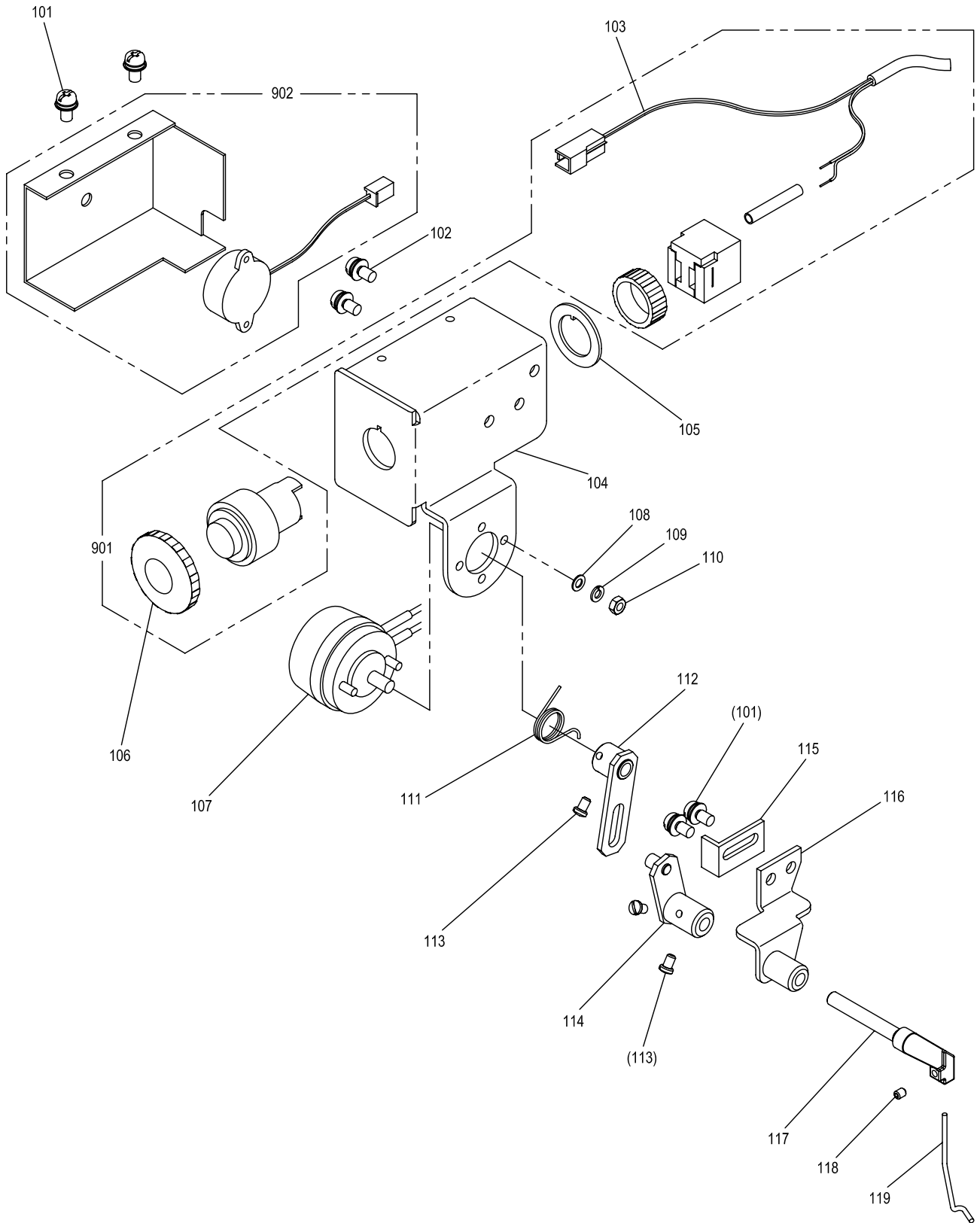

[M]ワイパー機構
WIPER MECHANISM

Fig no.	変更 Mod.	部品コード Parts no.	品名	Description	数量 Amt. Req.
M 101		M91054004	SW-PW ^ラ マイナ ^ベ ネジ ^{M4X8}	Screw M4X8.....	2
M 102		M91056004	SW-PW ^ラ マイナ ^ベ ネジ ^{M4X10}	Screw M4X10.....	4
M 103		M97356099	セツク ^テ ンセン.....	Cable (stop BZ).....	1
M 104		ME10E3601	トリツケ ^イ タ.....	Bracket.....	1
M 105		MB60A0915	ロック ^リ ング.....	Lock ring.....	1
M 106		ME03A0270	プッシュ ^ホ タン.....	Push button.....	1
M 107		MB61E1519	ワイパ ^ー ソレノ ^イ ド.....	Solenoid (wiper).....	1
M 108		M90317050	ザガ ^ネ 3.....	Washer 3.....	2
M 109		M90307053	ハネサ ^ガ ネ 3.....	Spring washer 3.....	2
M 110		M90875045	ナツ ^ト M3.....	Nut M3.....	2
M 111		MS02A4729	ヒネ ^リ ハ ^ネ	Spring.....	1
M 112		MS02E0983	ク ^ト ウ ^イ タ.....	Wiper crank.....	1
M 113		M90802003	マルヒ ^ラ ネジ ^{1/8(44)X4.5}	Screw 1/8(44)x4.5.....	4
M 114		MB61A0436	シュウ ^ト ウ ^イ タ.....	Wiper crank.....	1
M 115		MS02A1477	ストッ ^パ	Stopper.....	1
M 116		MS10A0982	ワイパ ^ー ダ ^イ	Wiper adapter.....	1
M 117		MB61E0982	ワイパ ^ー シ ^フ ク.....	Wiper shaft.....	1
M 118		M91057020	ロック ^ク ア ^ナ ツキ ^ト メ ^ネ ジ ^{M3X4}	Screw M3X4.....	1
M 119		MA20A0980	ワイパ ^ー	Wiper.....	1
M 901		ME10E0270	オン ^ホ タ ^ン ス ^イ ツ ^チ ク ^ミ	Switch assy.....	1
M 902		MB60E3339	カバ ^ー ク ^ミ (ブ ^ザ ー ^ツ キ).....	Cover assy (with buzzer).....	1

N 給油機構
OIL LUBRICATION MECHANISM

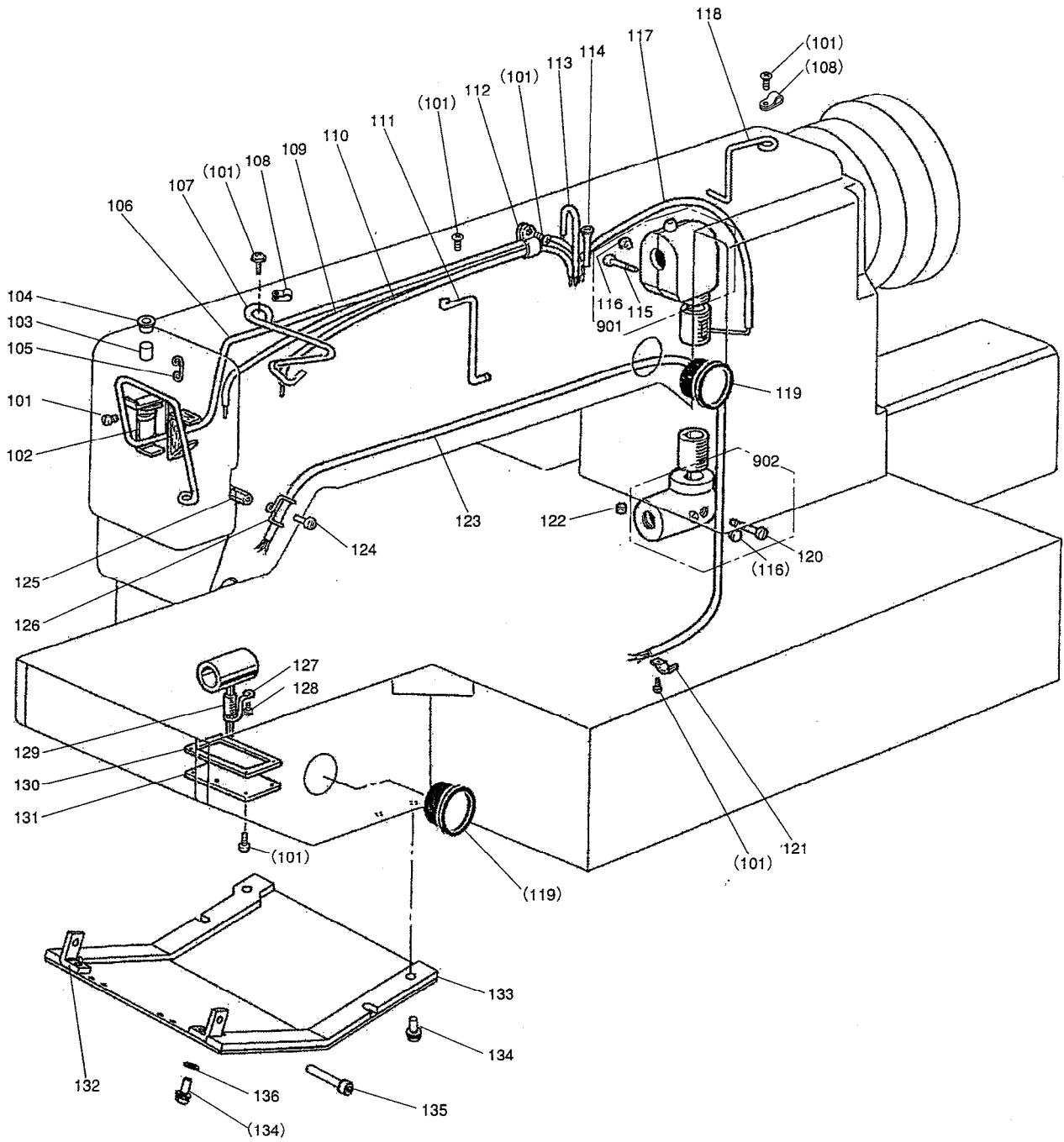

[N]給油機構

OIL LUBRICATION MECHANISM

Fig no.	変更 Mod.	部品コード Parts no.	品名	Description	数量 Amt. Req.
N 101		M91054004	SW-PWﾌﾟﾗﾏｲﾅﾍﾞﾈｼﾞ M4×8	Screw M4X8	9
N 102		ME10A1780	ホルﾀﾞ	Holder	1
N 103		MF10A2740	ﾌﾞﾙﾄ	Felt	1
N 104		MF60A0742	ﾌﾀ	Cap	1
N 105		MS03A2780	ホルﾀﾞ	Holder	1
N 106		MB25E0688	ﾊﾞｲﾌﾟﾋﾞｼﾞｮﾝ	Oil pipe complete	1
N 107		MB61A0780	ホルﾀﾞ	Holder	1
N 108		MS14A1620	ﾅｲﾛﾝｸﾘｯﾌﾟ AB-4N	Nylon clip AB-4N	2
N 109		MB25E1688	ﾊﾞｲﾌﾟﾋﾞｼﾞｮﾝ	Oil pipe complete	1
N 110		MB25E2688	ﾊﾞｲﾌﾟﾋﾞｼﾞｮﾝ	Oil pipe complete	1
N 111		MS10A0780	ホルﾀﾞ	Holder	1
N 112		MN60A0620	ﾅｲﾛﾝｸﾘｯﾌﾟ AB-5N	Nylon clip AB-5N	2
N 113		MB25E3688	ﾊﾞｲﾌﾟﾋﾞｼﾞｮﾝ	Oil pipe complete	1
N 114		MS10A0688	ﾊﾞｲﾌﾟ	Pipe	1
N 115		M90531037	Pﾏﾍﾞﾈｼﾞ M5X14	Screw M5X14	1
N 116		M90573080	ｺﾞﾑｾﾝ	Rubber plug	2
N 117		MB61E1688	ﾊﾞｲﾌﾟﾋﾞｼﾞｮﾝ	Oil pipe complete	1
N 118		ME20A2780	ホルﾀﾞ	Holder	1
N 119		MN10A0135	ｱﾌﾞﾗﾏﾄﾞ	Oil gauge	2
N 120		M95014021	ﾛｯｶﾞｱﾅﾅｯｷﾎﾙﾄ M5X14	Bolt M5X14	1
N 121		MF80A0780	ホルﾀﾞ	Holder	1
N 122		MF10A2740	ﾌﾞﾙﾄ	Felt	1
N 123		MA25E3688	ﾊﾞｲﾌﾟﾋﾞｼﾞｮﾝ	Oil pipe complete	1
N 124		M91015004	ﾌﾟﾗﾏｲﾅﾍﾞﾈｼﾞ M4X12	Screw M4X12	1
N 125		M91007045	ﾅｯﾄ M4	Nut M4	1
N 126		MF36A0689	ホルﾀﾞ	Holder	1
N 127		MG43A0689	ｾﾝｻｲｸﾊﾞﾈ	Pipe holder	1
N 128		M91058004	SW-PWﾌﾟﾗﾏｲﾅﾍﾞﾈｼﾞ M4X6	Screw M4X6	1
N 129		MB61E0688	ﾊﾞｲﾌﾟﾌﾞﾙﾄ	Oil pipe complete	1
N 130		MS10A1691	ｶﾞｽｹｯﾄ	Gasket	1
N 131		MS10A1742	ｱﾌﾞﾗﾌﾀ	Cap	1
N 132		ME27A0601	ﾄﾘｯﾌﾟ	Adapter	2
N 133		ME27E0742	ﾌﾀ	Cap assy	1
N 134		M91056004	SW-PWﾌﾟﾗﾏｲﾅﾍﾞﾈｼﾞ M4X10	Screw M4X10	6
N 135		M94024017	ｾﾌﾃｲﾝ	Bolt M4X20	1
N 136		M90422050	ｻﾞｶﾞﾈ 4	Washer 4	1
N 901		MB61E0711	ﾊﾞｲﾌﾟ	Arm shaft bevel gear box complete	1
N 902		MB61E0712	ﾊﾞｲﾌﾟ	Hook shaft bevel gear box complete	1

P 配線配管関係
CABLE COMPONENT & PNEUMATIC CONTROL UNIT

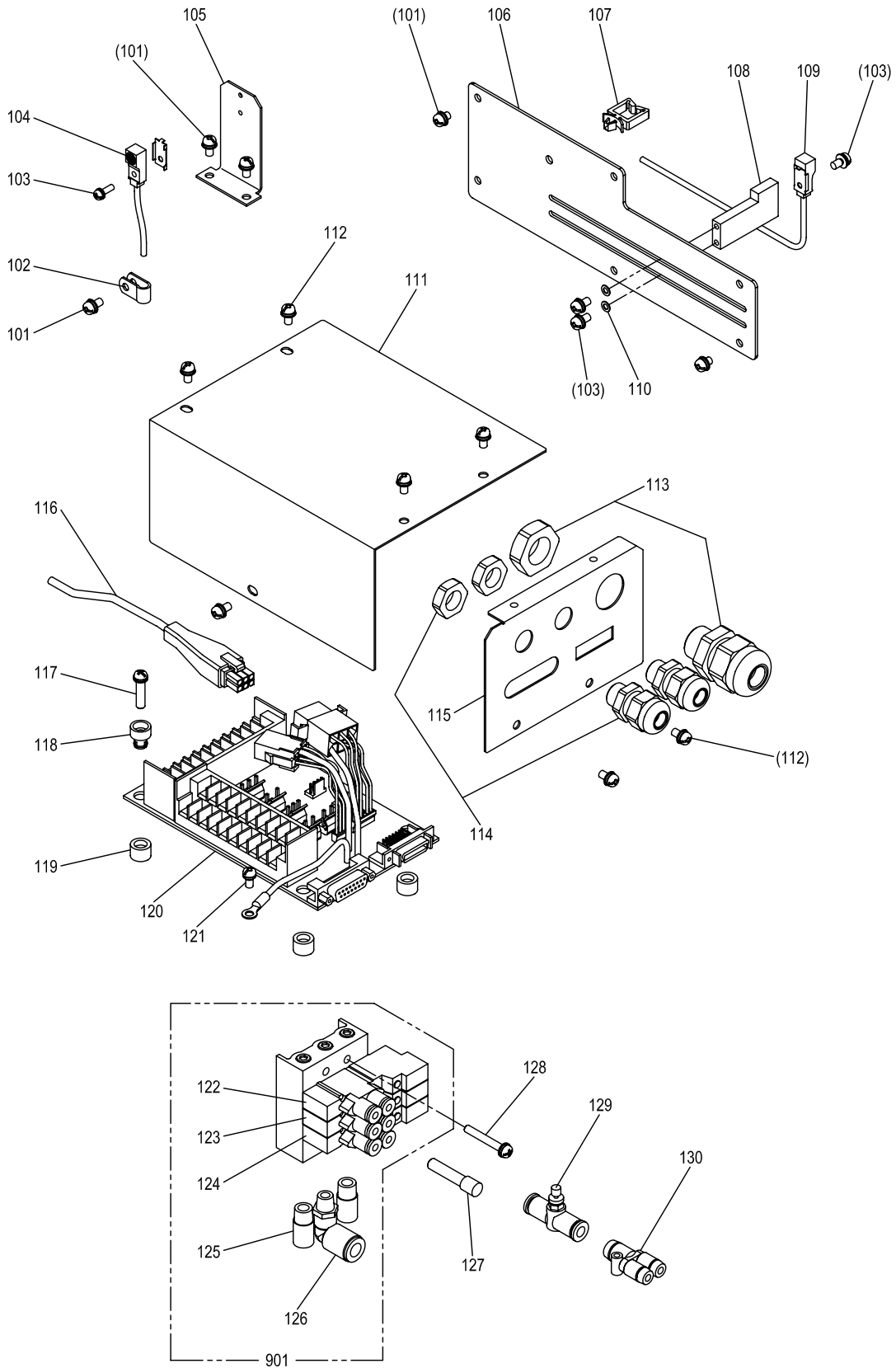

[P]配線・配管関係

CABLE COMPONENT & PNEUMATIC CONTROL UNIT

Fig no.	変更 Mod.	部品コード Parts no.	品名	Description	数量 Amt. Req.
P 101		M91054004	SW-PWﾌﾟﾗﾏｲﾅへﾞﾈｼﾞ M4X8	Screw M4X8	12
P 102		M94003099	ﾅｲﾛﾝｸﾘｯﾌﾟ AB-3N	Nylon clip AB-3N	4
P 103		M90971004	SW-PWﾌﾟﾗﾏｲﾅへﾞﾈｼﾞ M3X10	Screw M3X10	4
P 104		ME25A1484	ｷﾝｾｯｽｲｯﾁ X	Detector X	1
P 105		ME10A0408	ｹﾝｼﾞｬｯﾀﾞｲ X	Detector bracket X	1
P 106		ME25A2339	ｶﾊﾞｰ	Cover	1
P 107		ME25A0389	ｹｰﾌﾞﾙｸﾗﾝﾌﾟ	Cable clamp	1
P 108		ME25A0408	ｹﾝｼﾞｬｯﾀﾞｲ Y	Detector bracket Y	1
P 109		ME25A0484	ｷﾝｾｯｽｲｯﾁ Y	Detector Y	1
P 110		M90316050	ｻﾞｶﾞﾈ 3	Washer 3	2
P 111		MB60A5339	Pﾊﾞﾝｶﾊﾞｰ	Circuit board cover	1
P 112		M91071004	SW-MWﾌﾟﾗﾏｲﾅへﾞﾈｼﾞ M4X8	Screw M4X8	7
P 113		MB60A5780	ｺｰﾄﾞﾌﾞｯｼﾞ ﾀﾞｲ	Cord bushing (large)	1
P 114		MB60A6780	ｺｰﾄﾞﾌﾞｯｼﾞ ｼｮｰ	Cord bushing (small)	2
P 115		MB60A5601	ｺﾈｸﾀ外ﾘｯﾁ	Connector panel	1
P 116		K14M71725402	ｹｰﾌﾞﾙ (ｴﾝｺｰﾀﾞ)	Cable (encoder)	1
P 117		M91057004	SW-PWﾌﾟﾗﾏｲﾅへﾞﾈｼﾞ M4X20	Screw M4X20	4
P 118		MB60A0366	ﾜﾝﾀｯﾁﾌﾞｯｼﾞ	Nylon bush	4
P 119		MB60A2352	ﾜﾝﾀｯﾁﾌﾞｯｼﾞ	Nylon bush	4
P 120		M800E2CON	Pﾊﾞﾝｸﾐﾀﾞ	Print circuit board	1
P 121		M90439037	SWﾌﾟﾗﾏｲﾅへﾞﾈｼﾞ M4X8	Screw M4X8	1
P 122		MB62A1599	ﾃﾞﾝｼﾞｮﾞﾞ (ﾅｶｵｻｴ)	Solenoid valve (presser bar lifting)	1
P 123		MB62A2599	ﾃﾞﾝｼﾞｮﾞﾞ (ｼﾄｵｻｴ)	Solenoid valve (work holder)	1
P 124		MB62A3599	ﾃﾞﾝｼﾞｮﾞﾞ (ｲﾄｷﾘ)	Solenoid valve (Thread trimming)	1
P 125		M91035089	ｻｲﾚﾝｻ AN101-01	Muffler	2
P 126		MA20A8571	Lｶﾞﾀｯｷﾞ ｸﾞ KQL08-01S	L-type quick joint	1
P 127		MB62A0757	ﾌﾟﾗｸﾞ	Plug	1
P 128		M91276004	SW-PWﾌﾟﾗﾏｲﾅへﾞﾈｼﾞ M4X30	Screw M4X30	4
P 129		MA16A0495	ｽﾋﾟｰﾄﾞｺﾝﾄﾛｰﾗ AS1001-F06	Speed controller	1
P 130		MA20A6571	ｲｹｲｳﾆｵﾝ Y KJU04-06	Y-type quick joint	1
P 901		MB25E0599	ﾃﾞﾝｼﾞｮﾞﾞ ｸﾞ ｸﾐﾀﾞ	Solenoid valve assy	1

Q テーブル関係
TABLE & STAND

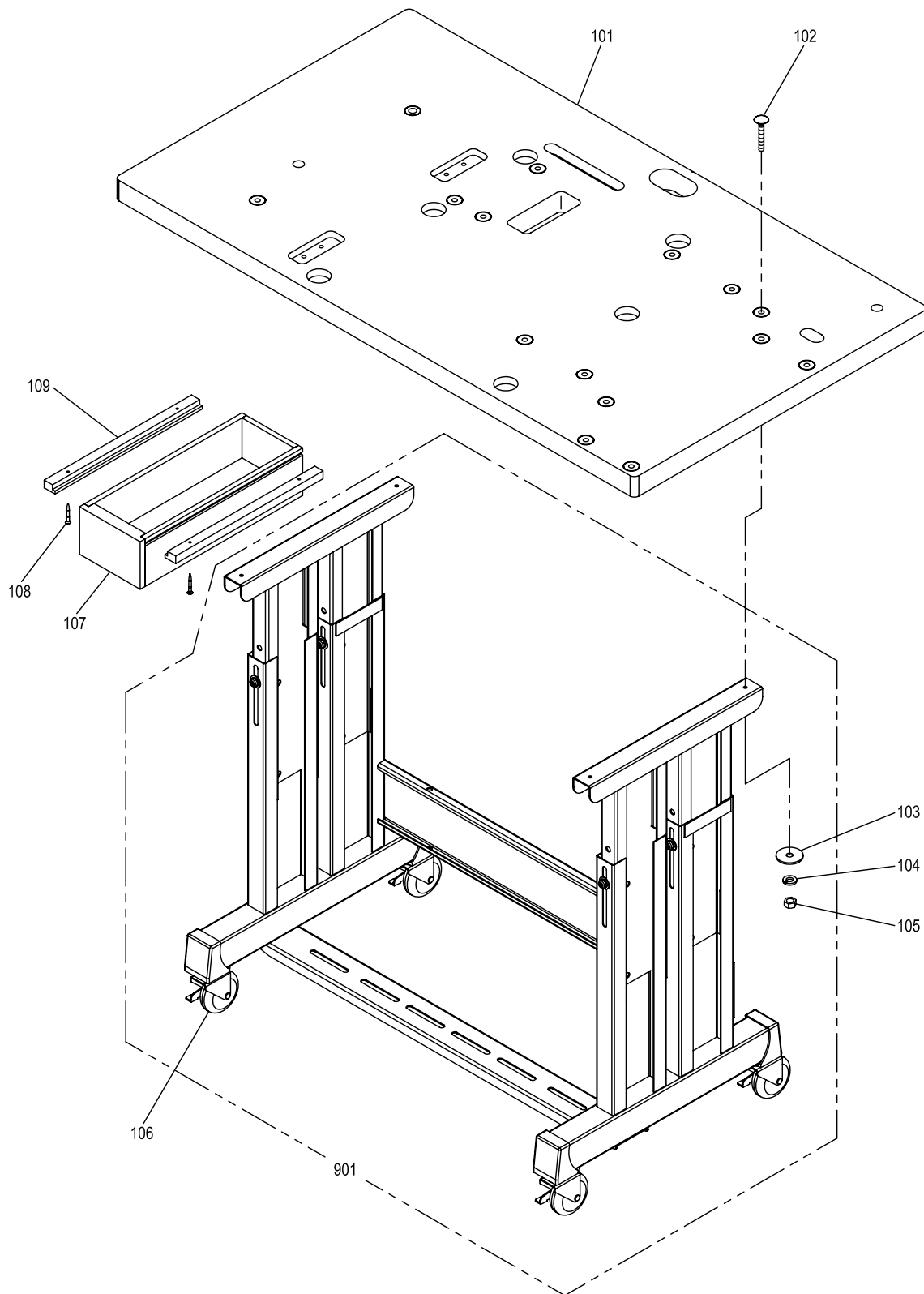

[Q]テーブル関係
TABLE & STAND

Fig no.	変更 Mod.	部品コード Parts no.	品名	Description	数量 Amt. Req.
Q 101		MB25A0595	テシイタ	Table top	1
Q 102		M98011022	トリツケホルト M8X60	Mounting bolt M8X60	4
Q 103		M90710050	トクシユサガネ 8	Special washer 8	4
Q 104		M90802053	ハネサガネ 8	Spring washer 8	4
Q 105		M92008045	ナツト M8	Nut M8	4
Q 106		MB60A1368	キャスト	Caster	4
Q 107		MB60A0719	ヒキタシ	Drawer	1
Q 108		M90406040	Pサラモクネジ φ4.5X38	Wooden screw φ4.5X38	4
Q 109		MB60A3957	レール	Rail	2
Q 901		MB60E0150	キヤククミタテ	Leg assy	1

R 付属品(1)
ACCESSORIES(1)

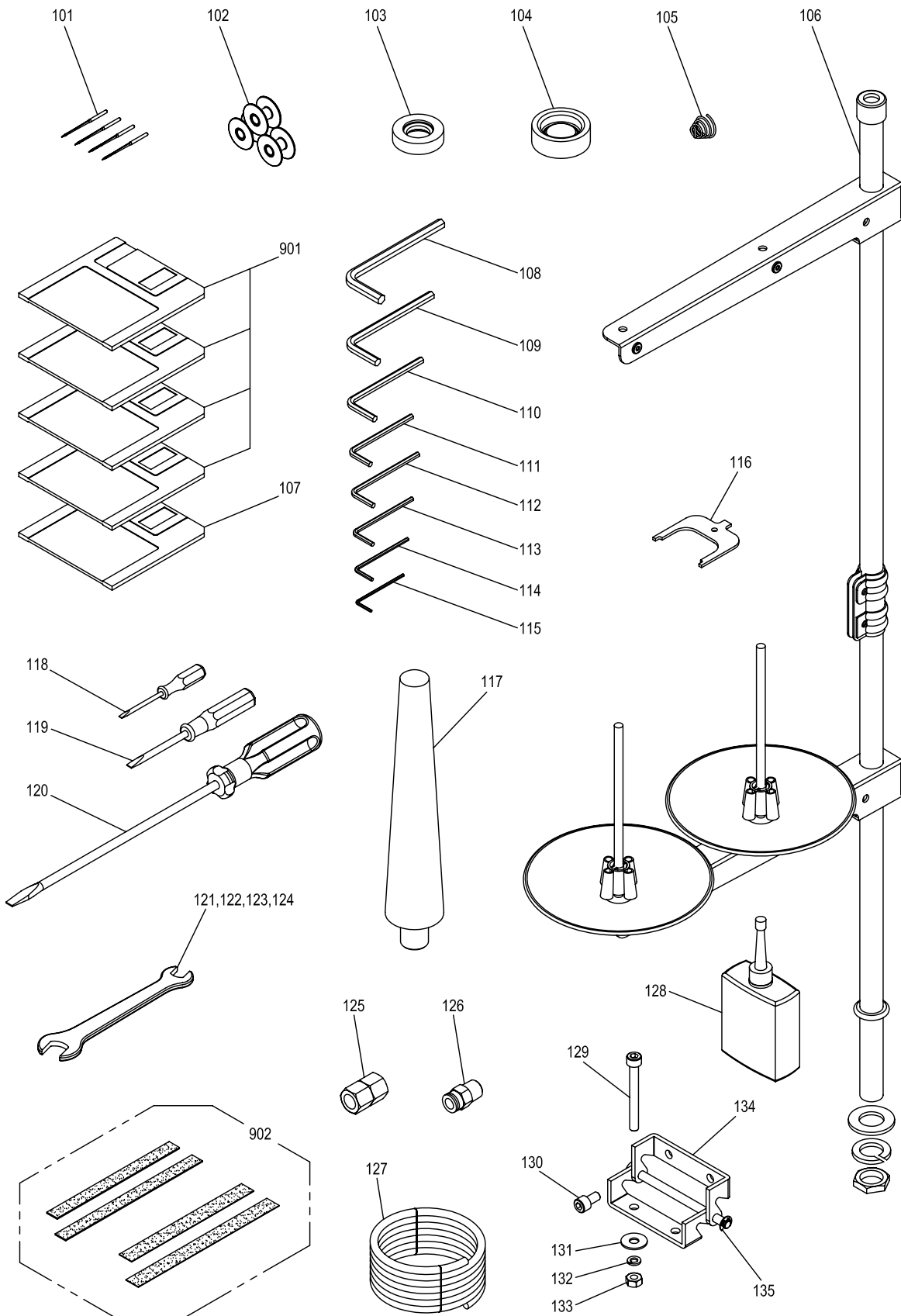

[R] 付属品(1)
ACCESSORIES(1)

Fig no.	変更 Mod.	部品コード Parts no.	品名	Description	数量 Amt. Req.
R 101		MS02A0128	ミシンハリ DPX17#18	Needle DPX17#18	4
R 102		MF25B0123	ホビン	Bobbin	3
R 103		MS03A0417	ゴムワ (イマキヨウ)	Tire (for bobbin winder)	1
R 104		MB60A0419	ホウシンゴム	Rubber cushion	6
R 105		MN52A1245	エンスイバネ	Tension spring	1
R 106		MF40E0193	イタテダイクミタテ	Cotton stand assy	1
R 107		MB60A1990	データフロッピーディスク	Pattern data F/D	1
R 108		MS05A1976	ロッカホウレンチ 6	Hexagonal wrench 6	1
R 109		MS05A0976	ロッカホウレンチ 5	Hexagonal wrench 5	1
R 110		MF90A0976	ロッカホウレンチ 1/8"	Hexagonal wrench 1/8"	1
R 111		MS01A1976	ロッカホウレンチ 4	Hexagonal wrench 4	1
R 112		MS02A2976	ロッカホウレンチ 3	Hexagonal wrench 3	1
R 113		MS02A1976	ロッカホウレンチ 2.5	Hexagonal wrench 2.5	1
R 114		MS02A0976	ロッカホウレンチ 2	Hexagonal wrench 2	1
R 115		MS10A0976	ロッカホウレンチ 1.5	Hexagonal wrench 1.5	1
R 116		MF01A0565	カドチョウセイグ	Speed command disk adjusting plate	1
R 117		MB25A0613	トウフササエ	Head rest	1
R 118		MB02A1608	ドライバ (ショウ)	Screw driver (small)	1
R 119		MB02A0608	ドライバ (チュウ)	Screw driver (middle)	1
R 120		MF00A0608	ドライバ (ダイ)	Screw driver (large)	1
R 121		MS02A0479	スパナ 13-17	Spanner 13-17	1
R 122		MM10A1479	スパナ 10-14	Spanner 10-14	1
R 123		MS10A1976	スパナ 8-9	Spanner 8-9	1
R 124		MS10A2976	スパナ 6-7	Spanner 6-7	1
R 125		M91010089	ロッカクソケット YST-2ガタ NP-202	Socket	1
R 126		MA30A0571	ワンタッチツギテ KQH08-02S	Quick joint	1
R 127		MS06A0567	エアチューブ	Air tube	1
R 128		MF10A0149	アブラサシ	Oiler with oil	1
R 129		M96020021	ロッカクアナツキボルト M6X55	Bolt M6x55	4
R 130		M96002017	セフティソケット M6X12	Bolt M6x12	4
R 131		M90630050	サガネ 6.5-18	Washer 6.5-18	4
R 132		M90624053	バネサガネ 6	Spring washer 6	4
R 133		M91576045	ナット M6	Nut M6	4
R 134		MB60A0560	チョウハン	Hinge	2
R 135		M90809065	Eガタメワ 5	E-type retaining ring 5	1
R 901		ME20E0990	システムフロッピーディスク (4マイ)	System F/D (4discs)	1
R 902		ME25E0691	ハッキンセット	Clamp pad set	1

S 付属品(2)
ACCESSORIES(2)

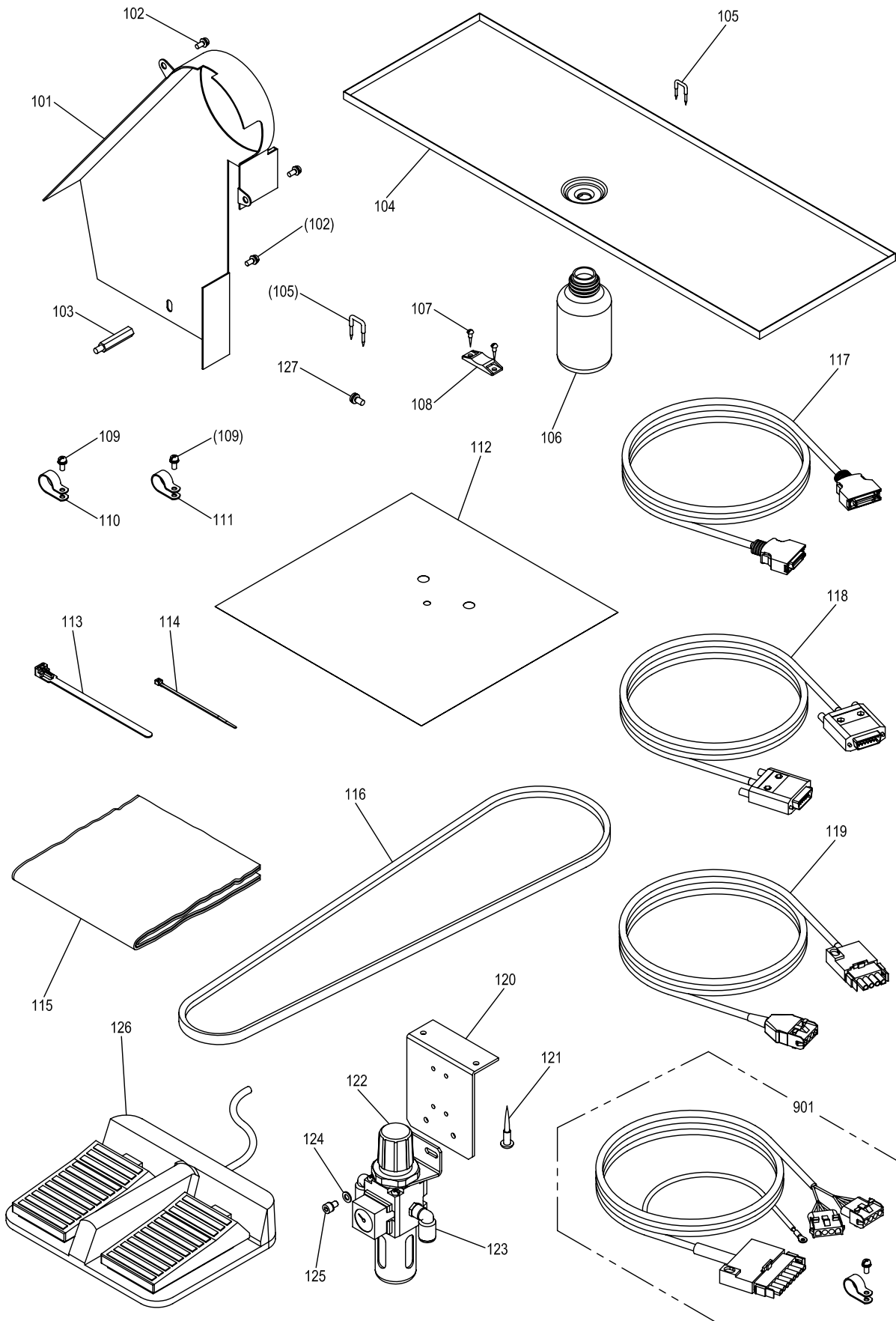

[S] 付属品(2)
ACCESSORIES(2)

Fig no.	変更 Mod.	部品コード Parts no.	品 名	Description	数量 Amt. Req.
S 101		MB62E0776	ベルトカバー	Belt cover	1
S 102		M91067004	SW-PWネジ M5X10	Screw M5X10	3
S 103		M95001031	トクショボルト M5	Special bolt M5	1
S 104		MB25E0131	アブラウケ	Oil pan	1
S 105		M90001043	ステッフル	Staple	7
S 106		MF20A0130	アブラビン	Oil bottle	1
S 107		M90306041	マルモクネジ 3.1X16	Wood screw 3.1x16	4
S 108		MB60A0420	コタイゲ	Tie holder	2
S 109		M91056004	SW-PWネジ M4X10	Screw M4X10	2
S 110		MB60A2620	ナイロンクリップ AB-10N	Nylon clip AB-10N	1
S 111		MB60A1620	ナイロンクリップ AB-8N	Nylon clip AB-8N	1
S 112		MB62A0797	ホゴフィルム	Film sheet	1
S 113		MB60A0201	ハインダー	Cord tie	2
S 114		MG51A0201	ハインダー	Cord tie	1
S 115		MA20A0734	ビニルカバー	Polyethylene cover	1
S 116		MB62A0777	Vベルト M46	V-belt M46	1
S 117		M97319099	ケーブル (ニューリヨクシンコウ)	Cable (input signal)	1
S 118		M97320099	ケーブル (ソレノイド)	Cable (solenoid)	1
S 119		M97318099	ケーブル (サーボモータデンゲン)	Cable (servo motor)	1
S 120		MB61A5601	レギュレータリツケイタ	Filter regulator adapter	1
S 121		M90409041	マルモクネジ 4.5X20	Screw 4.5X20	2
S 122		ME40A0963	フィルタレギュレータ (ステーツキ)	Filter regulator	1
S 123		MA20A8571	Lカタツキテ KQL08-01S	L-type quick joint	2
S 124		M90511050	ザガネ 5	Washer 5	2
S 125		M95003017	セフティソケット M5X8	Bolt M5X8	2
S 126		M860A0FSW	フットスイッチ	Foot switch	1
S 127		M90439037	SWネジ M4X8	Screw M4X8	1
S 901		M97321099	ケーブル (パルスモータ)	Cable (pulse motor)	1

T オプションパーツ
OPTION PARTS

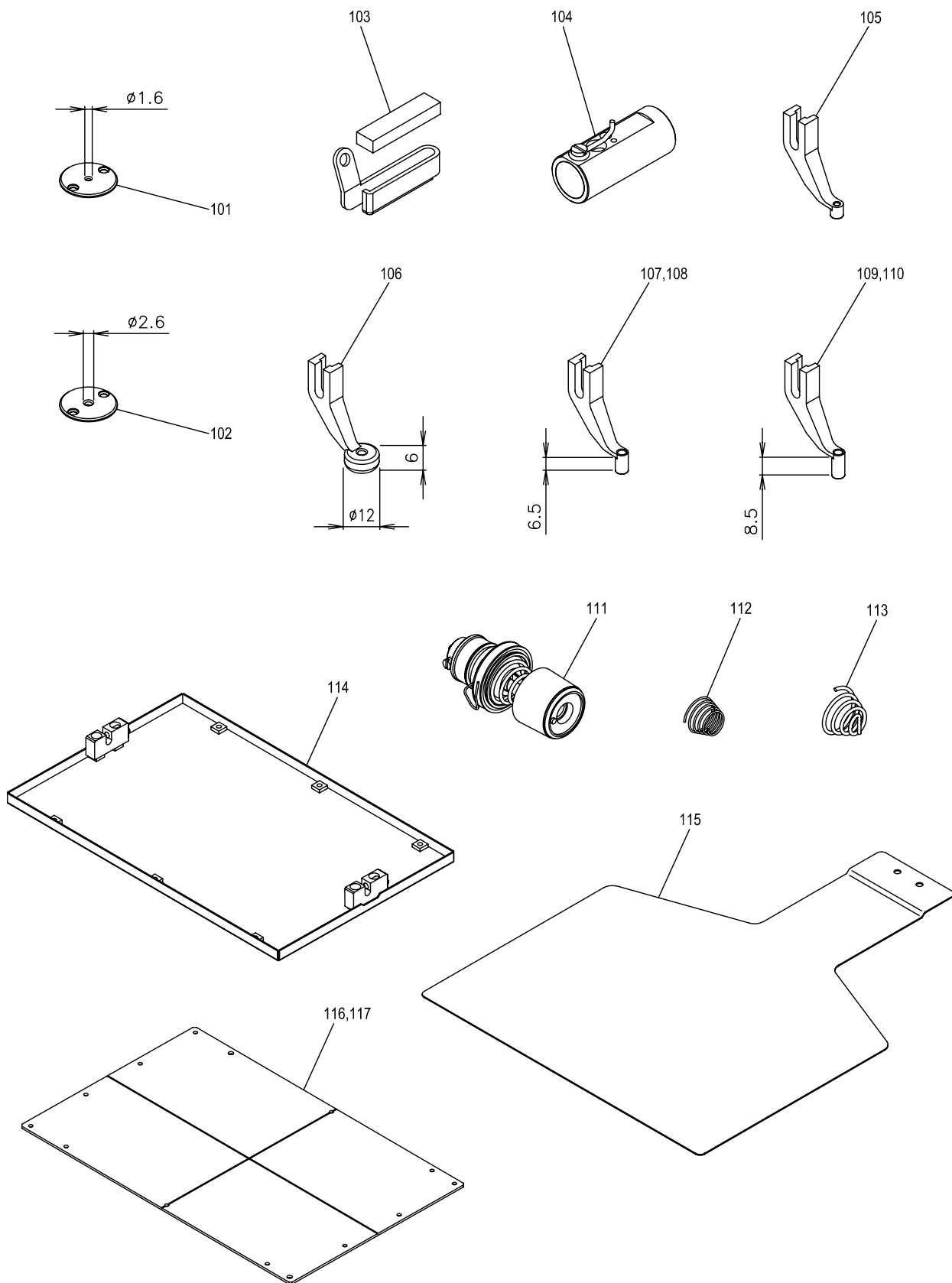

[T]オプションパーツ
OPTION PARTS

Fig no.	変更 Mod.	部品コード Parts no.	品 名	Description	数量 Amt. Req.
T 101		MS02A0101	ハリイタ φ1.6	Needle plate φ1.6	1
T 102		MS02A1101	ハリイタ φ2.6	Needle plate φ2.6	1
T 103		MS03A0181	イトアンナイ	Thread guide	1
T 104		MS10A0180	イトアンナイ	Thread guide	1
T 105		MV30A1256	ナカオサエ (ウスモノヨウ)	Presser foot (for light)	1
T 106		MV35A0106	サラオサエ φ3	Presser foot φ3	1
T 107		MS03A0256	ナカオサエ φ3	Presser foot φ3	1
T 108		MS03A1256	ナカオサエ φ2	Presser foot φ2	1
T 109		MA35A0256	ナカオサエ φ3	Presser foot φ3	1
T 110		MA35A1256	ナカオサエ φ2	Presser foot φ2	1
T 111		MS04E1210	ウワイトチョウセツキ (クミ)	Thread tension regulator assy	1
T 112		MF10A1245	エンスイハネ (プリテンションヨウ)	Spring (for pretension)	1
T 113		MN10A3245	エンスイハネ (ウワイトチョウセツキヨウ)	Spring (for thread tension regulator)	1
T 114		MB25E1105	ソトオサエクミタテ (アナナシ)	Clamp frame assy (blank)	1
T 115		MB25A1272	シタオサエイタ (アナナシ)	Feed plate (blank)	1
T 116		MB62A0762	ナカオサエイタ (2T,ケガキセンアリ)	Clamp plate (with line)	1
T 117		MB62A1762	ナカオサエイタ (2T,ケガキセンナシ)	Clamp plate	1

索引
INDEX-1

部品コード Parts No.	ページ Page	Fig No.	部品コード Parts No.	ページ Page	Fig No.	部品コード Parts No.	ページ Page	Fig No.	部品コード Parts No.	ページ Page	Fig No.
K14M71725402	...	P27	...	P	116	M90803010	...	P15	...	H	146
M800E2CON	...	P27	...	P	120	M90806002	...	P3	...	B	123
M860A0FSW	...	P33	...	S	126	M90809065	...	P31	...	R	135
M90001043	...	P33	...	S	105	M90814004	...	P17	...	J	102
M90103036	...	P7	...	D	133	M90815002	...	P9	...	E	130
M90204060	...	P5	...	C	127	M90816004	...	P17	...	J	120
M90306041	...	P33	...	S	107	M90823050	...	P3	...	B	108
M90307053	...	P23	...	M	109	M90834050	...	P15	...	H	154
M90316050	...	P27	...	P	110	M90859004	...	P3	...	B	119
M90317050	...	P23	...	M	108	↑	...	P19	...	K	118
↑	...	P17	...	J	101	↑	...	P5	...	C	104
M90325065	...	P13	...	G	128	M90875045	...	P23	...	M	110
M90330065	...	P9	...	E	105	M90883080	...	P3	...	B	106
M90406040	...	P29	...	Q	108	M90901002	...	P5	...	C	123
M90406064	...	P9	...	E	140	M90906003	...	P3	...	B	131
M90409041	...	P33	...	S	121	M90907010	...	P15	...	H	134
M90421050	...	P15	...	H	108	M90909003	...	P13	...	G	115
↑	...	P9	...	E	102	↑	...	P5	...	C	115
↑	...	P17	...	J	129	M90913001	...	P15	...	H	132
↑	...	P19	...	K	128	M90920002	...	P7	...	D	108
↑	...	P21	...	L	112	M90921002	...	P15	...	H	138
M90422050	...	P25	...	N	136	M90922002	...	P13	...	G	139
M90423060	...	P13	...	G	145	M90939002	...	P7	...	D	109
M90424053	...	P15	...	H	107	M90971004	...	P27	...	P	103
M90439037	...	P27	...	P	121	M90990002	...	P7	...	D	136
↑	...	P33	...	S	127	↑	...	P15	...	H	136
M90448037	...	P19	...	K	109	↑	...	P3	...	B	138
M90501053	...	P15	...	H	126	↑	...	P9	...	E	135
M90504065	...	P21	...	L	106	↑	...	P11	...	F	119
M90505037	...	P19	...	K	110	M91004067	...	P7	...	D	118
M90511050	...	P21	...	L	111	M91005067	...	P7	...	D	120
↑	...	P33	...	S	124	M91007045	...	P15	...	H	106
↑	...	P3	...	B	144	↑	...	P21	...	L	113
↑	...	P17	...	J	148	↑	...	P25	...	N	125
M90512050	...	P17	...	J	143	M91010089	...	P31	...	R	125
M90531037	...	P25	...	N	115	M91011004	...	P5	...	C	110
M90532060	...	P21	...	L	107	M91013004	...	P21	...	L	109
M90552050	...	P15	...	H	125	↑	...	P7	...	D	103
M90573080	...	P3	...	B	117	M91015004	...	P25	...	N	124
↑	...	P25	...	N	116	M91035089	...	P27	...	P	125
M90602064	...	P7	...	D	122	M91053020	...	P5	...	C	117
M90604065	...	P17	...	J	132	↑	...	P19	...	K	113
M90605010	...	P3	...	B	136	↑	...	P9	...	E	120
M90611060	...	P19	...	K	121	M91054004	...	P15	...	H	156
M90624053	...	P31	...	R	132	↑	...	P7	...	D	102
M90630050	...	P31	...	R	131	↑	...	P23	...	M	101
M90631050	...	P13	...	G	123	↑	...	P25	...	N	101
↑	...	P3	...	B	114	↑	...	P27	...	P	101
M90632050	...	P13	...	G	133	↑	...	P3	...	B	103
M90710050	...	P29	...	Q	103	M91055004	...	P3	...	B	121
M90800086	...	P11	...	F	117	M91055020	...	P21	...	L	126
M90801006	...	P11	...	F	116	↑	...	P7	...	D	111
M90802002	...	P15	...	H	102	M91056004	...	P25	...	N	134
M90802003	...	P23	...	M	113	↑	...	P23	...	M	102
M90802053	...	P29	...	Q	104	↑	...	P13	...	G	104
M91056004	...	P33	...	S	109	M91057004	...	P27	...	P	117
M91057004	...	P27	...	P	117	M91057020	...	P23	...	M	118
M91057020	...	P23	...	M	118	↑	...	P7	...	D	114
↑	...	P7	...	D	114	M91058004	...	P3	...	B	129
M91058004	...	P3	...	B	129	↑	...	P5	...	C	102
↑	...	P5	...	C	102	↑	...	P25	...	N	128
↑	...	P25	...	N	128	M91058020	...	P13	...	G	113
M91058020	...	P13	...	G	113	M91059004	...	P9	...	E	103
M91059004	...	P9	...	E	103	M91066004	...	P3	...	B	128
M91066004	...	P3	...	B	128	M91067004	...	P33	...	S	102
M91067004	...	P33	...	S	102	↑	...	P3	...	B	116
↑	...	P3	...	B	116	M91069004	...	P15	...	H	116
M91069004	...	P15	...	H	116	M91071004	...	P27	...	P	112
M91071004	...	P27	...	P	112	↑	...	P17	...	J	140
↑	...	P17	...	J	140	↑	...	P3	...	B	102
↑	...	P3	...	B	102	M91081004	...	P19	...	K	122
M91081004	...	P19	...	K	122	M91101046	...	P5	...	C	122
M91101046	...	P5	...	C	122	M91106001	...	P11	...	F	110
M91106001	...	P11	...	F	110	M91107045	...	P15	...	H	143
M91107045	...	P15	...	H	143	M91110002	...	P3	...	B	122
M91110002	...	P3	...	B	122	M91110045	...	P15	...	H	131
M91110045	...	P15	...	H	131	M91111015	...	P15	...	H	150
M91111015	...	P15	...	H	150	M91112002	...	P15	...	H	109
M91112002	...	P15	...	H	109	M91117002	...	P15	...	H	148
M91117002	...	P15	...	H	148	M91119002	...	P9	...	E	142
M91119002	...	P9	...	E	142	M91127015	...	P15	...	H	101
M91127015	...	P15	...	H	101	M91131002	...	P13	...	G	146
M91131002	...	P13	...	G	146	M91151010	...	P15	...	H	140
M91151010	...	P15	...	H	140	M91182080	...	P5	...	C	116
M91182080	...	P5	...	C	116	M91201045	...	P15	...	H	119
M91201045	...	P15	...	H	119	M91202045	...	P15	...	H	151
M91202045	...	P15	...	H	151	M91212015	...	P15	...	H	155
M91212015	...	P15	...	H	155	M91219015	...	P13	...	G	147
M91219015	...	P13	...	G	147	M91221001	...	P9	...	E	124
M91221001	...	P9	...	E	124	M91276004	...	P27	...	P	128
M91276004	...	P27	...	P	128	M91304080	...	P3	...	B	105
M91304080	...	P3	...	B	105	M91382045	...	P21	...	L	125
M91382045	...	P21	...	L	125	↑	...	P15	...	H	112
↑	...	P15	...	H	112	M91501022	...	P15	...	H	120
M91501022	...	P15	...	H	120	M91502045	...	P15	...	H	123
M91502045	...	P15	...	H	123	M91504031	...	P13	...	G	144
M91504031	...	P13	...	G	144	M91506001	...	P13	...	G	136
M91506001	...	P13	...	G	136	M91512022	...	P15	...	H	124
M91512022	...	P15	...	H	124	M91520002	...	P9	...	E	112
M91520002	...	P9	...	E	112	M91551015	...	P13	...	G	125
M91551015	...	P13	...	G	125	M91572045	...	P13	...	G	122
M91572045	...	P13	...	G	122	M91576045	...	P31	...	R	133
M91576045	...	P31	...	R	133	M91602001	...	P9	...	E	118
M91602001	...	P9	...	E	118	M91602020	...	P11	...	F	113
M91602020	...	P11	...	F	113	M91602046	...	P7	...	D	123
M91602046	...	P7	...	D	123	M91603003	...	P13	...	G	121
M91603003	...	P13	...	G	121	M91606001	...	P13	...	G	129
M91606001	...	P13	...	G	129	↑	...	P9	...	E	132
↑	...	P9	...	E	132	M91610001	...	P11	...	F	102
M91610001	...	P11	...	F	102	M91610001	...	P9	...	E	144
M91610001	...	P9	...	E	144	M91610046	...	P5	...	C	132
M91610046	...	P5	...	C	132	M91688015	...	P13	...	G	109
M91688015	...	P13	...	G	109	M91689015	...	P13	...	G	107
M91689015	...	P13	...	G	107	M91801035	...	P13	...	G	101
M91801035	...	P13	...	G	101	M91802006	...	P9	...	E	131
M91802006	...	P9	...	E	131	M91802045	...	P13	...	G	102
M91802045	...	P13	...	G	102	M91803022	...	P3	...	B	111
M91803022	...	P3	...	B	111	M91910080	...	P5	...	C	111
M91910080	...	P5	...	C	111	M92008045	...	P29	...	Q	105
M92008045	...	P29	...	Q	105	M92514045	...	P19	...	K	104
M92514045	...	P19	...	K	104	M93001050	...	P9	...	E	106
M93001050	...	P9	...	E	106	M93004021	...	P17	...	J	107
M93004021	...	P17	...	J	107	M93202047	...	P13	...	G	131
M93202047	...	P13	...	G	131	M93220035	...	P13	...	G	130
M93220035	...	P13	...	G	130	M94001017	...	P17	...	J	112
M94001017	...	P17	...	J	112	↑	...	P21	...	L	118
↑	...	P21	...	L	118	M94003099	...	P27	...	P	102
M94003099	...	P27	...	P	102	M94006017	...	P19	...	K	129
M94006017	...	P19	...	K	129	M94006052	...	P15	...	H	145
M94006052	...	P15	...	H	145	M94008017	...	P17	...	J	119
M94008017	...	P17	...	J	119	M94008070	...	P21	...	L	117
M94008070	...	P21	...	L	117	M94012017	...	P21	...	L	123
M94012017	...	P21	...	L	123	M94015021	...	P21	...	L	114
M94015021	...	P21	...	L	114	M94018017	...	P15	...	H	157
M94018017	...	P15	...	H	157	M94024017	...	P25	...	N	135
M94024017	...	P25	...	N	135	M95001017	...	P21	...	L	110
M95001017	...	P21	...	L	110	M95001031	...	P33	...	S	103
M95001031	...	P33	...	S	103	M95002017	...	P3	...	B	143
M95002017	...	P3									

索引
INDEX-2

部品コード Parts No.	ページ Page	Fig No.	部品コード Parts No.	ページ Page	Fig No.	部品コード Parts No.	ページ Page	Fig No.	部品コード Parts No.	ページ Page	Fig No.
M97318099	... P33	... S 119	MB25A1476	... P7	... D 139	MB61A0740	... P9	... E 123	MB62E1957	... P17	... J 109
M97319099	... P33	... S 117	MB25A1477	... P17	... J 117	MB61A0758	... P17	... J 141	MB62E2477	... P17	... J 111
M97320099	... P33	... S 118	MB25A1601	... P5	... C 101	MB61A0767	... P17	... J 139	ME03A0270	... P23	... M 106
M97321099	... P33	... S 901	MB25A2339	... P7	... D 130	MB61A0780	... P25	... N 107	ME10A0261	... P13	... G 103
M97356099	... P23	... M 103	MB25A2601	... P5	... C 106	MB61A0797	... P3	... B 139	ME10A0408	... P27	... P 105
M98011022	... P29	... Q 102	MB25A3339	... P7	... D 137	MB61A1454	... P17	... J 146	ME10A0572	... P13	... G 105
M99002022	... P19	... K 115	MB25A3601	... P5	... C 107	MB61A1459	... P3	... B 134	ME10A0742	... P3	... B 104
M99006063	... P7	... D 113	MB25A4601	... P17	... J 104	MB61A1477	... P21	... L 116	ME10A0763	... P13	... G 111
↑	... P13	... G 114	MB25B1339	... P7	... D 131	MB61A1601	... P3	... B 125	ME10A0956	... P13	... G 124
MA16A0495	... P27	... P 129	MB25B1426	... P19	... K 123	MB61A1758	... P17	... J 144	ME10A1252	... P13	... G 142
MA16A0530	... P7	... D 107	MB25B1476	... P7	... D 138	MB61A2459	... P3	... B 135	ME10A1780	... P25	... N 102
MA16A0621	... P15	... H 159	MB25E0105	... P19	... K 901	MB61A2767	... P17	... J 145	ME10A1956	... P13	... G 118
MA16E0210	... P5	... C 902	MB25E0131	... P33	... S 104	MB61A3454	... P21	... L 102	ME10A6910	... P13	... G 110
MA20A0194	... P7	... D 115	MB25E0522	... P11	... F 902	MB61A5601	... P33	... S 120	ME10A7910	... P13	... G 112
MA20A0257	... P5	... C 103	MB25E0599	... P27	... P 901	MB61E0234	... P9	... E 904	ME10E0270	... P23	... M 901
MA20A0458	... P5	... C 105	MB25E0688	... P25	... N 106	MB61E0351	... P15	... H 901	ME10E3601	... P23	... M 104
MA20A0476	... P7	... D 104	MB25E1105	... P35	... T 114	MB61E0434	... P15	... H 902	ME20A0120	... P11	... F 120
MA20A0603	... P15	... H 111	MB25E1688	... P25	... N 109	MB61E0452	... P11	... F 903	ME20A0352	... P13	... G 158
MA20A0650	... P19	... K 126	MB25E2688	... P25	... N 110	MB61E0521	... P11	... F 901	ME20A0406	... P9	... E 101
MA20A0734	... P33	... S 115	MB25E3688	... P25	... N 113	MB61E0688	... P25	... N 129	ME20A0426	... P13	... G 108
MA20A0980	... P23	... M 119	MB45A0767	... P17	... J 122	MB61E0711	... P25	... N 901	ME20A0530	... P13	... G 157
MA20A4920	... P17	... J 110	MB60A0201	... P33	... S 113	MB61E0712	... P25	... N 902	ME20A0830	... P3	... B 120
MA20A5571	... P15	... H 158	MB60A0366	... P27	... P 118	MB61E0750	... P7	... D 112	ME20A2780	... P25	... N 118
MA20A5920	... P17	... J 106	MB60A0419	... P31	... R 104	MB61E0982	... P23	... M 117	ME20E0190	... P7	... D 901
MA20A6571	... P27	... P 130	MB60A0420	... P33	... S 108	MB61E1519	... P23	... M 107	ME20E0477	... P15	... H 121
MA20A8571	... P33	... S 123	MB60A0429	... P17	... J 118	MB61E1688	... P25	... N 117	ME20E0990	... P31	... R 901
↑	... P27	... P 126	MB60A0560	... P31	... R 134	MB62A0228	... P19	... K 124	ME25A0339	... P3	... B 112
MA21P0454	... P17	... J 133	MB60A0694	... P9	... E 111	MB62A0263	... P21	... L 124	ME25A0389	... P27	... P 107
MA22A0477	... P21	... L 120	MB60A0719	... P29	... Q 107	MB62A0455	... P19	... K 114	ME25A0408	... P27	... P 108
MA22A2957	... P21	... L 121	MB60A0750	... P3	... B 109	MB62A0456	... P17	... J 121	ME25A0416	... P9	... E 145
MA25A0572	... P15	... H 128	MB60A0915	... P23	... M 105	MB62A0523	... P17	... J 130	ME25A0434	... P13	... G 153
MA25A0601	... P15	... H 160	MB60A1368	... P29	... Q 106	MB62A0572	... P21	... L 115	ME25A0454	... P9	... E 139
MA25A0660	... P9	... E 126	MB60A1429	... P17	... J 114	MB62A0626	... P13	... G 140	ME25A0477	... P13	... G 149
MA25A0891	... P15	... H 130	MB60A1601	... P7	... D 117	MB62A0707	... P21	... L 108	ME25A0484	... P27	... P 109
MA25E3688	... P25	... N 123	MB60A1620	... P33	... S 111	MB62A0757	... P27	... P 127	ME25A0530	... P7	... D 110
MA30A0571	... P31	... R 126	MB60A1990	... P31	... R 107	MB62A0762	... P35	... T 116	ME25A0551	... P7	... D 105
MA35A0256	... P35	... T 109	MB60A2352	... P27	... P 119	MB62A0767	... P17	... J 134	ME25A0571	... P13	... G 152
MA35A1256	... P35	... T 110	MB60A2601	... P17	... J 115	MB62A0777	... P33	... S 116	ME25A0601	... P13	... G 151
MA35A1781	... P17	... J 131	MB60A2620	... P33	... S 110	MB62A0797	... P33	... S 112	ME25A0682	... P9	... E 141
MA35A2572	... P9	... E 138	MB60A3957	... P29	... Q 109	MB62A0921	... P19	... K 102	ME25A0692	... P19	... K 103
MA35A6758	... P17	... J 136	MB60A5339	... P27	... P 111	MB62A0950	... P21	... L 101	ME25A0781	... P19	... K 106
MB02A0608	... P31	... R 119	MB60A5601	... P27	... P 115	MB62A0957	... P21	... L 122	ME25A0921	... P19	... K 111
MB02A1608	... P31	... R 118	MB60A5780	... P27	... P 113	MB62A1434	... P21	... L 105	ME25A0950	... P7	... D 106
MB25A0230	... P9	... E 121	MB60A6780	... P27	... P 114	MB62A1523	... P17	... J 138	ME25A1484	... P27	... P 104
MB25A0272	... P19	... K 116	MB60E0150	... P29	... Q 901	MB62A1599	... P27	... P 122	ME25A1833	... P9	... E 137
MB25A0359	... P7	... D 134	MB60E0682	... P9	... E 113	MB62A1762	... P35	... T 117	ME25A2339	... P27	... P 106
MB25A0390	... P17	... J 124	MB60E1682	... P9	... E 901	MB62A1957	... P21	... L 119	ME25E0331	... P9	... E 906
MB25A0426	... P3	... B 142	MB60E3339	... P23	... M 902	MB62A2407	... P17	... J 116	ME25E0691	... P31	... R 902
MB25A0476	... P7	... D 135	MB61A0148	... P11	... F 104	MB62A2454	... P19	... K 101	ME27A0339	... P3	... B 118
MB25A0477	... P17	... J 108	MB61A0436	... P23	... M 114	MB62A2599	... P27	... P 123	ME27A0390	... P19	... K 105
MB25A0595	... P29	... Q 101	MB61A0459	... P3	... B 133	MB62A2921	... P19	... K 112	ME27A0477	... P19	... K 125
MB25A0613	... P31	... R 117	MB61A0470	... P3	... B 140	MB62A3599	... P27	... P 124	ME27A0600	... P7	... D 101
MB25A0742	... P3	... B 107	MB61A0571	... P17	... J 125	MB62E0776	... P33	... S 101	ME27A0601	... P25	... N 132
MB25A1272	... P35	... T 115	MB61A0601	... P3	... B 115	MB62E0849	... P3	... B 101	ME27A0738	... P13	... G 148
MB25A1339	... P7	... D 132	MB61A0650	... P3	... B 132	MB62E0957	... P17	... J 103	ME27E0519	... P15	... H 114

索引
INDEX-3

部品コード Parts No.	ページ Page	Fig No.	部品コード Parts No.	ページ Page	Fig No.	部品コード Parts No.	ページ Page	Fig No.	部品コード Parts No.	ページ Page	Fig No.
ME27E0742	... P25	... N 133	MF60A0740	... P11	... F 106	MS02A1477	... P23	... M 115	MV88A0740	... P9	... E 116
ME27E0746	... P15	... H 115	MF60A0742	... P25	... N 104	MS02A1976	... P31	... R 113			
ME40A0454	... P19	... K 117	MF60A1383	... P9	... E 905	MS02A2456	... P17	... J 135			
ME40A0571	... P13	... G 155	MF70A0350	... P13	... G 143	MS02A2976	... P31	... R 112			
ME40A0963	... P33	... S 122	MF70A0352	... P9	... E 117	MS02A4729	... P23	... M 111			
MF00A0181	... P5	... C 118	MF70A1180	... P5	... C 133	MS02B0257	... P19	... K 119			
MF00A0391	... P15	... H 153	MF80A0780	... P25	... N 121	MS02E0460	... P13	... G 119			
MF00A0392	... P15	... H 147	MF90A0361	... P15	... H 104	MS02E0983	... P23	... M 112			
MF00A0411	... P15	... H 118	MF90A0553	... P5	... C 119	MS03A0181	... P35	... T 103			
MF00A0412	... P15	... H 117	MF90A0976	... P31	... R 110	MS03A0256	... P35	... T 107			
MF00A0453	... P11	... F 112	MG30A0700	... P11	... F 115	MS03A0262	... P13	... G 138			
MF00A0608	... P31	... R 120	MG30A0740	... P13	... G 117	MS03A0417	... P7	... D 116			
MF00A0750	... P15	... H 129	MG30A0760	... P13	... G 901	↑	... P31	... R 103			
MF00A1477	... P15	... H 122	MG30A0833	... P13	... G 120	MS03A1256	... P35	... T 108			
MF00A1527	... P15	... H 139	MG30B0740	... P13	... G 127	MS03A2780	... P25	... N 105			
MF00A1603	... P15	... H 135	MG42A0181	... P9	... E 128	MS03A6154	... P13	... G 106			
MF00A8910	... P15	... H 149	MG43A0181	... P5	... C 109	MS04E1210	... P35	... T 111			
MF00E0550	... P5	... C 901	MG43A0689	... P25	... N 127	MS05A0976	... P31	... R 109			
MF01A0259	... P9	... E 107	MG43A1181	... P5	... C 114	MS05A1976	... P31	... R 108			
MF01A0476	... P9	... E 110	MG44E0125	... P11	... F 122	MS05E0580	... P9	... E 902			
MF01A0565	... P31	... R 116	MG44E0662	... P9	... E 133	MS06A0567	... P31	... R 127			
MF01A1476	... P9	... E 108	MG50A0740	... P9	... E 114	MS07A0180	... P15	... H 137			
MF01E0350	... P11	... F 904	MG51A0201	... P33	... S 114	MS07A0228	... P15	... H 105			
MF01E0352	... P11	... F 111	MG75A0265	... P13	... G 135	MS07A0782	... P15	... H 142			
MF02A0834	... P15	... H 141	MG75A1476	... P7	... D 129	MS07A0836	... P15	... H 144			
MF03A0584	... P5	... C 112	MM10A1479	... P31	... R 122	MS07A1603	... P15	... H 152			
MF10A0149	... P31	... R 128	MM11A0245	... P7	... D 125	MS10A0180	... P35	... T 104			
MF10A0181	... P5	... C 113	MM11A0556	... P5	... C 129	MS10A0192	... P3	... B 141			
MF10A0187	... P5	... C 125	MM11A0702	... P7	... D 124	MS10A0232	... P9	... E 903			
MF10A0267	... P13	... G 137	MN10A0135	... P25	... N 119	MS10A0451	... P11	... F 114			
MF10A0325	... P9	... E 134	MN10A1456	... P9	... E 104	MS10A0663	... P9	... E 125			
MF10A0332	... P11	... F 109	MN10A3245	... P35	... T 113	MS10A0688	... P25	... N 114			
MF10A0334	... P11	... F 108	MN52A1245	... P31	... R 105	MS10A0740	... P11	... F 105			
MF10A0553	... P5	... C 126	↑	... P5	... C 130	MS10A0780	... P25	... N 111			
MF10A0555	... P7	... D 126	MN55A0975	... P21	... L 104	MS10A0838	... P15	... H 133			
↑	... P5	... C 128	MN60A0620	... P25	... N 112	MS10A0976	... P31	... R 115			
MF10A0664	... P9	... E 127	MN60A0750	... P15	... H 113	MS10A0982	... P23	... M 116			
MF10A0709	... P5	... C 124	MN70A1780	... P13	... G 116	MS10A1456	... P3	... B 110			
MF10A1245	... P35	... T 112	MN70E1148	... P11	... F 107	MS10A1691	... P25	... N 130			
MF10A1555	... P5	... C 120	MN72A1694	... P9	... E 109	MS10A1740	... P9	... E 115			
MF10A2740	... P25	... N 122	MS01A0160	... P3	... B 126	MS10A1742	... P25	... N 131			
↑	... P25	... N 103	MS01A0361	... P3	... B 130	MS10A1976	... P31	... R 123			
MF20A0130	... P33	... S 106	MS01A0477	... P3	... B 127	MS10A2976	... P31	... R 124			
MF20A0229	... P11	... F 118	MS01A1976	... P31	... R 111	MS13A0572	... P19	... K 120			
MF20A0703	... P13	... G 132	MS02A0101	... P35	... T 101	MS14A0350	... P7	... D 119			
MF25B0123	... P31	... R 102	MS02A0128	... P9	... E 129	MS14A0553	... P7	... D 127			
↑	... P11	... F 121	↑	... P31	... R 101	MS14A0572	... P7	... D 121			
MF36A0245	... P5	... C 121	MS02A0259	... P13	... G 134	MS14A0682	... P9	... E 119			
MF36A0689	... P25	... N 126	MS02A0463	... P13	... G 902	MS14A1180	... P7	... D 128			
MF36A0750	... P15	... H 103	MS02A0479	... P31	... R 121	MS14A1620	... P25	... N 108			
MF36A1180	... P5	... C 108	MS02A0778	... P19	... K 108	MS14E0180	... P7	... D 902			
MF40A0331	... P9	... E 143	MS02A0976	... P31	... R 114	MT60A0802	... P5	... C 131			
MF40A0333	... P11	... F 101	MS02A1101	... P3	... B 137	MV30A0256	... P13	... G 141			
MF40E0193	... P31	... R 106	↑	... P35	... T 102	MV30A1256	... P35	... T 105			
MF60A0700	... P13	... G 126	MS02A1454	... P17	... J 149	MV35A0106	... P35	... T 106			

MEMO

A series of horizontal dotted lines for writing.

MEMO

A series of horizontal dotted lines for writing.

MEMO

A series of horizontal dotted lines for writing.

 **三菱電機株式会社**

 **MITSUBISHI ELECTRIC CORPORATION**