

Teileliste und Näheinrichtungen
Spare Parts List and Sewing Equipment

550-16-23; -26

DÜRKOPP ADLER AG

550-16-23; -26

Inhaltsverzeichnis	Tafel/Table	Contents
Oberteil	1 - 5	Machine head
Säulenkopf, kpl.	6	Head for pillar, cpl.
Greifer	7	Hook
Oberteil	8, 9	Machine head
Nähantrieb	10	Motor
Gestell	11	Stand
Bedienfeld	12	Control panel
Elektronik	13	Electronics
Beipack	14	Accessoires
Nähleuchte	15	Sewing lamp
Pläne		Plans

Alle Rechte vorbehalten.

Eigentum der Dürkopp Adler AG und urheberrechtlich geschützt. Jede, auch auszugsweise Wiederverwendung dieser Inhalte ist ohne vorheriges schriftliches Einverständnis der Dürkopp Adler AG verboten.

All rights reserved.

Property of Dürkopp Adler AG and copyrighted. Reproduction or publication of the content in any manner, even in extracts, without prior written permission of Dürkopp Adler AG, is prohibited.

Copyright © Dürkopp Adler AG - 2009

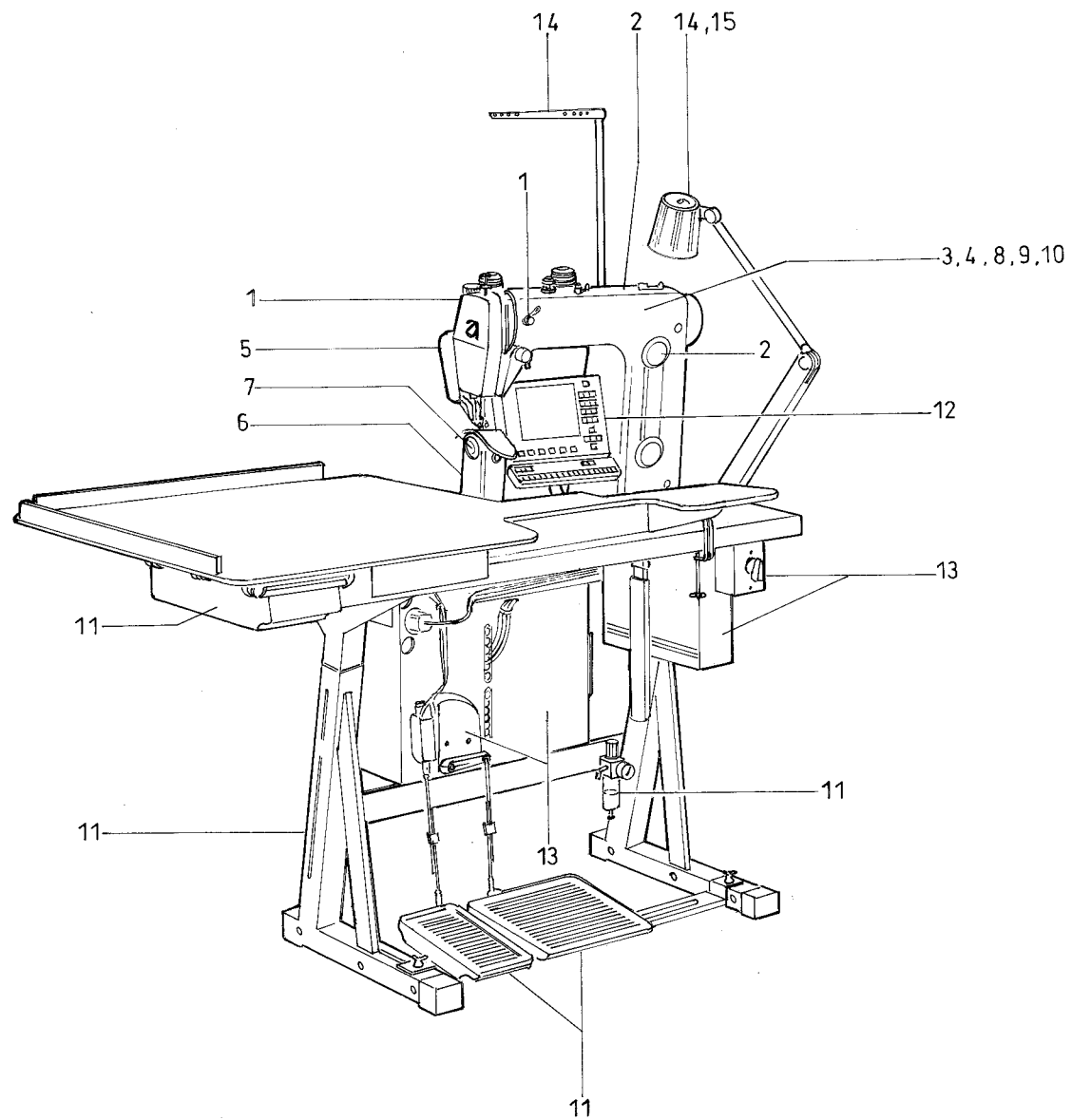

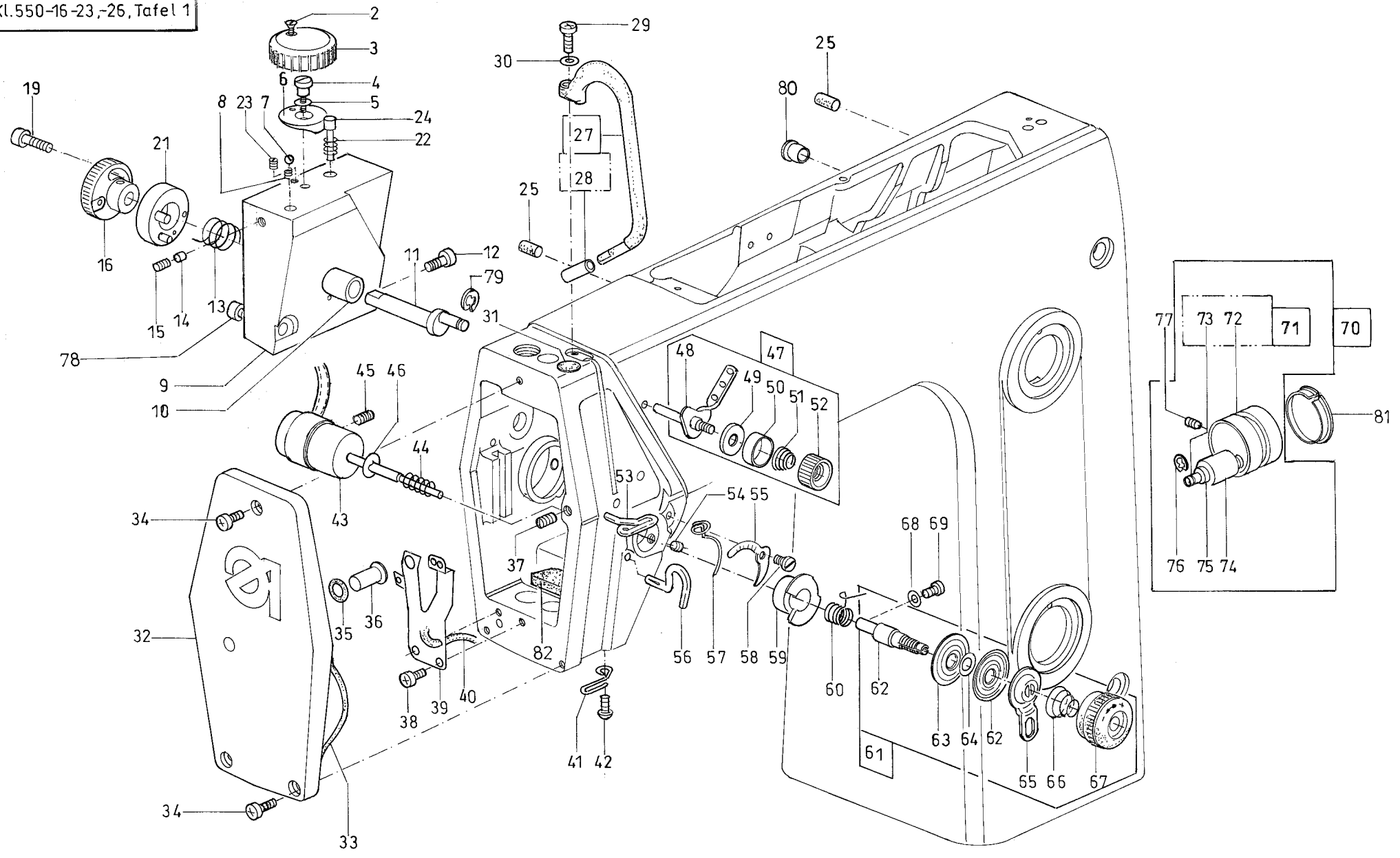

Pos.	Teile-Nr. / Part no.	Benennung	Denomination
		OBERTEIL	MACHINE HEAD
2	9203 313047	Senkschr.	countersunk screw
3	6279 340460	Einstellknopf	regulating button
4	0993 991910	Fl. Kopfschr.	screw
5	0998 881520	Passscheibe (0,5)	adjusting washer (0,5)
5	0998 885050	Passscheibe (0,15)	adjusting washer (0,15)
6	0568 340090	Einstellscheibe	regulating washer
7	0996 060250	Kugel	ball
8	0098 002990	Druckfeder	pressure spring
9	6279 130183	Lagerbock V	fit bracket cpl.
9		(Mit Pos. 10)	(with pos. 10)
10	0568 340530	Buchse	bushing
11	0271 130160	Exzenterbolzen	excentric bolt
12	9202 002093	Zyl. Schraube	cyl. screw
13	0396 342580	Drehfeder	torsion spring
14	0396 343150	Bolzen	bolt
15	9205 102178	Gew. Stift	threaded pin
16	0271 130170	Bundbuchse	bushing
19	9202 002073	Zyl. Schraube	cyl. screw
21	0396 343073	Stellscheibe	setting washer
22	0030 001340	Feder	spring
23	0271 000756	Gew. Stift	threaded pin
24	0271 130190	Piston	piston
25	0216 000288	Gummistopfen	rubber plug
27	0540 100830	Fadenhebelschutz K	guard bow cpl.
27		(Mit Pos. 28)	(with pos. 28)
28	0271 000124	Huelse	sleeve
29	9204 201668	Linsenschraube	fillister head screw
30	9330 000088	Scheibe	washer
31	0271 000029	Stopfen, Schutz	cap
32	0171 100103	Kopfdeckel	face cover
33	0271 000227	Runddichtung	rubber ring
34	9204 201677	Linsenschraube	fillister head screw
35	0216 000224	Runddichtring	rubber ring
36	0171 130010	Druckknopf	pressure pin

Pos.	Teile-Nr. / Part no.	Benennung	Denomination
37	0216 001146	Gewindestift	threaded pin
38	9204 201648	Zyl. Schr.	cyl. head screw
39	0271 000187	Blattfeder K	leaf spring
40	9041 100035	Oeldocht	oil wick
41	0271 000222	Fadenfuehrung	thread guide
42	9217 300518	Linsenschraube	fillister head screw
43	9700 100059	Zylinder, Einf.	cylinder
44	0935 103438	Druckfeder	pressure spring
45	9205 102168	Gewindestift	threaded pin
46	0271 001385	Scheibe	washer
47	0271 001391	Fadenleitwinkel K	thread angle cpl.
47		(Mit Pos. 48-52)	(with pos. 48-52)
48	0271 001392	Fadenleitwinkel V	thread angle
49	0244 000415	Spannungshuelse	tension sleeve
50	0244 000414	Spannhuelse	clamping sleeve
51	0271 001397	Druckfeder	pressure spring
52	0367 115250	Raendelmutter	knurled nut
53	0271 000217	Fadenfuehrung	thread guide
54	9205 102168	Gewindestift	threaded pin
55	0271 000215	Skalablech	scale plate
56	0211 000459	Fadenleithaken	thread guide hook
57	0271 000212	Fadenregulator	thread regulator
58	9203 113671	Zyl. Schr.	cyl. screw
59	0211 050215	Anschlaghuelse	stop sleeve
60	0271 000197	Anzugsfeder	torsion spring
61	0271 000236	Spannung K	tension cpl.
61		(Mit Pos. 62-67)	(with pos. 62-67)
62	0271 000237	Spannungsbolzen	tension bolt
63	0211 050214	Spannungsscheibe	tension washer
64	0271 000201	Ring	ring
65	0271 000199	Stegscheibe	stay disc
66	0004 000079	Spannungsfeder	tension spring
67	0540 110080	Spannungsknopf	tension wheel
68	0271 000200	Runddichtring	rubber ring
69	9203 113983	Flachkopfschr.	screw
70	0767 150144	Spannrolle K.	belt tensioner cpl.
70		(Mit Pos. 71, 74 - 76)	(with pos. 71, 74 - 76)

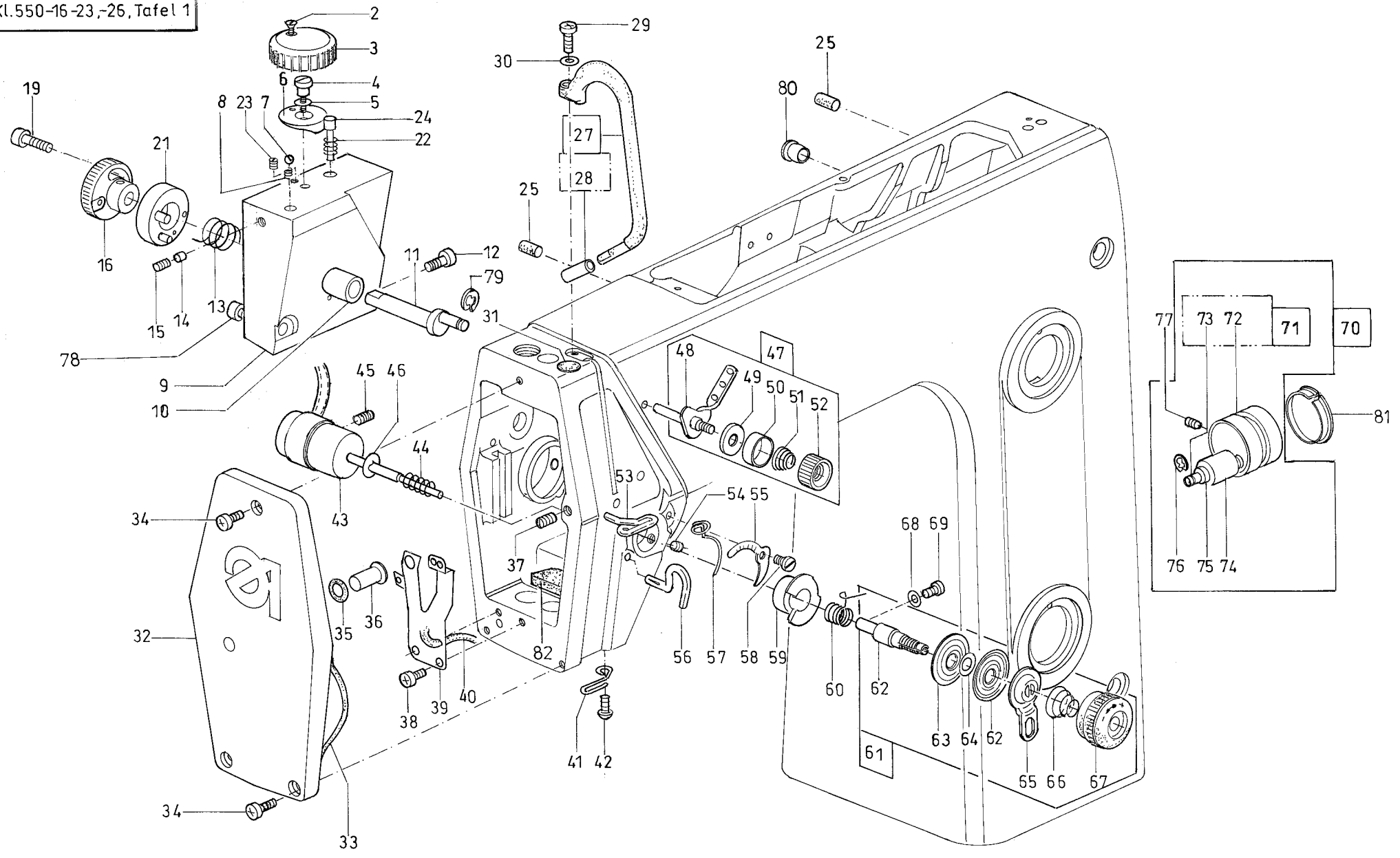

Pos.	Teile-Nr. / Part no.	Benennung	Denomination
71	0767 150143	Spannrolle V (Mit Pos. 72, 73)	belt tensioner cpl. (with pos. 72, 73)
72	0767 150140	Spannr. Lager	belt tension bearing
73	0767 150150	Bolzen	bolt
74	0296 150013	Lager	bearing
75	0053 000350	Scheibe	washer
76	9357 000090	Sich. Scheibe	safety bands
77	9205 102788	Gew. Stift	threaded stud
78	9202 002507	Zyl. Schr.	cyl. screw
79	9357 000060	Sich. Scheibe	safety bands
80	9390 000010	Stopfen	plug
81	6279 340500	Abdeckkappe	cover
82	0271 000009	Filz	felt

Pos.	Teile-Nr. / Part no.	Benennung	Denomination
------	----------------------	-----------	--------------

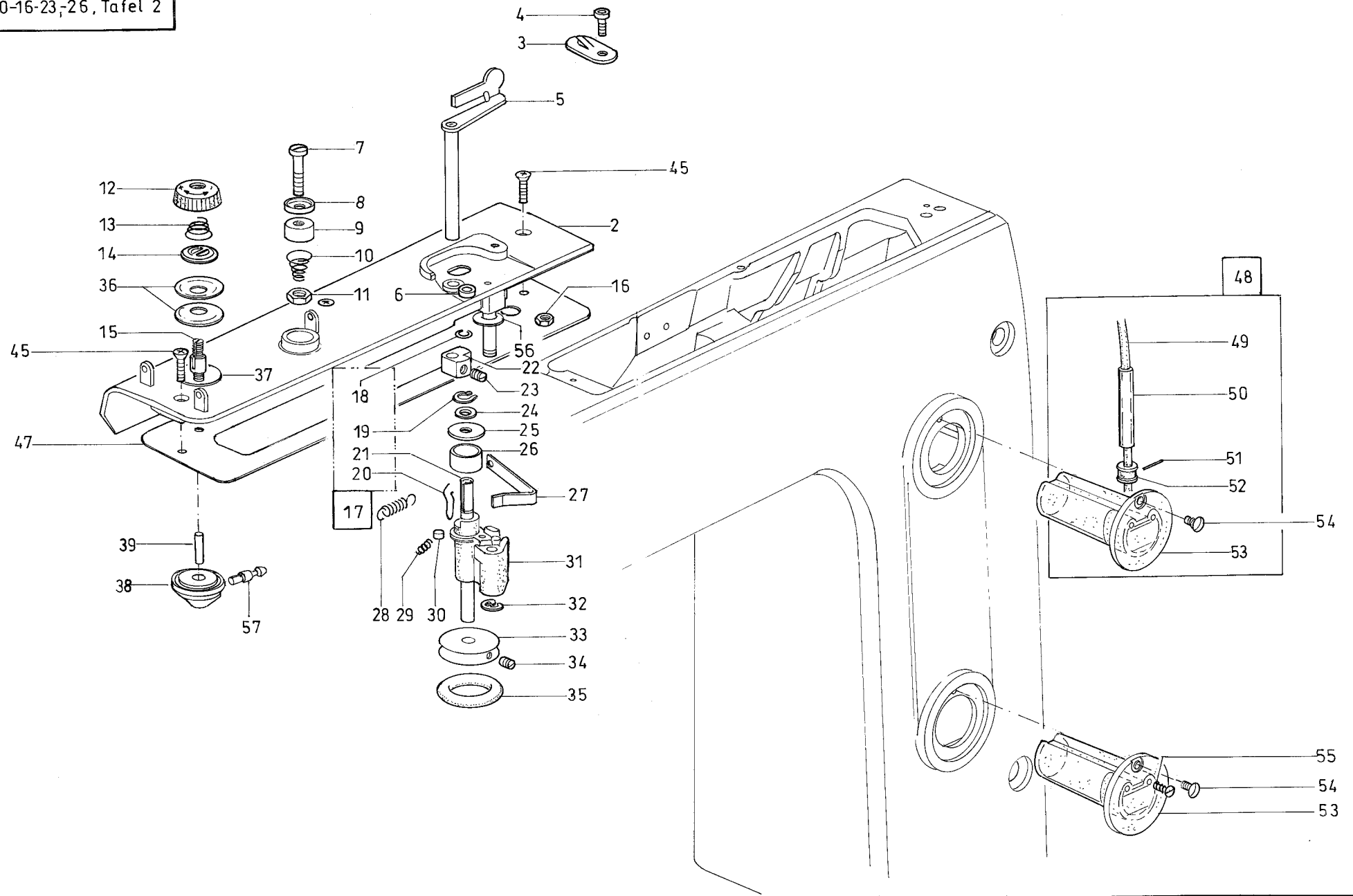

Pos.	Teile-Nr. / Part no.	Benennung	Denomination
		OBERTEIL	MACHINE HEAD
2	6279 100040	Spulerdeckel	bobbin winder
3	0271 000260	Abreissmesser	tear off knife
4	9217 300528	Linsenschr.	fillister head screw
5	0271 000262	Spulerklappe V	bobbin case flap
6	0002 008930 0100	Oelschlauch	oil hose
7	9204 201723	Linsenschr.	fillister head screw
8	0244 000415	Spannungshulse	tension sleeve
9	0244 000414	Spannhuelse	tension sleeve
10	0271 001397	Druckfeder	pressure spring
11	9231 000378	6Kt. Mutter	hexagonal nut
12	0540 110080	Skalaknopf	tension wheel
13	0004 000079	Spannungsfeder	tension spring
14	0114 000202	Stegscheibe	stay disc
15	0171 003043	Spann. Bolzen	tension bolt
16	9231 110058	6Kt. Mutter	hexagonal nut
17	0271 000273	Spulerspindel K	bobbin spindle cpl.
17		(Mit Pos. 18-21)	(with pos. 18-21)
18	0271 000276	Sprengring	spring ring
19	9352 000060	Sich. Ring	lock ring
20	0271 000275	Spulenfeder	bobbin winder spring
21	0271 000274	Spulerspindel	bobbin spindle cpl.
22	0216 000603	Schaltkloben	tripping block .
23	0223 000648	Gew. Stift	threaded stud
24	0244 000396	Scheibe	washer
25	0244 000401	Scheibe	washer
26	0244 000398	Ring	ring
27	0244 000403	Blattfeder	leaf spring
28	0244 000404	Zugfeder	draw spring
29	0244 000400	Druckfeder	pressure spring
30	0244 000399	Zylinderrolle	cylinder roller
31	0246 000466	Spulerbock	bobbin winder support
32	9357 000070	Sich. Scheibe	lock washer
33	1001 003102	Spulerrad	bobbin winder wheel
34	9205 023658	Gewindestift	threaded stud

Pos.	Teile-Nr. / Part no.	Benennung	Denomination
35	0216 000591	Friktionsbelag	frictioning
36	0211 050214	Spannungsscheibe	tension washer
37	6279 110010	Scheibe	washer
38	0195 350014	Zylinder V	cylinder cpl.
39	0933 002284	Nadelrolle	roller
45	0271 000298	Linsensenkschr.	screw
47	0271 000300	Dichtung	gasket
48	0271 000301	Oelbehälter K	oil container cpl.
48		(Mit Pos. 49-53)	(with pos. 49-53)
49	9041 100030	Oeldocht	oil wick
50	9731 001035	Oelschlauch	oil hose
51	0620 760092	Draht	wire pin
52	0211 000013	Kunstst. Muffe	bushing
53	0933 001533	Oelbehälter V	oil container cpl.
54	0219 000353	Linsenschr.	fillister head screw
55	9203 100001	Linsenschr.	screw
56	0998 881020	Scheibe	washer
57	0797 002205	Verbindung	coupling

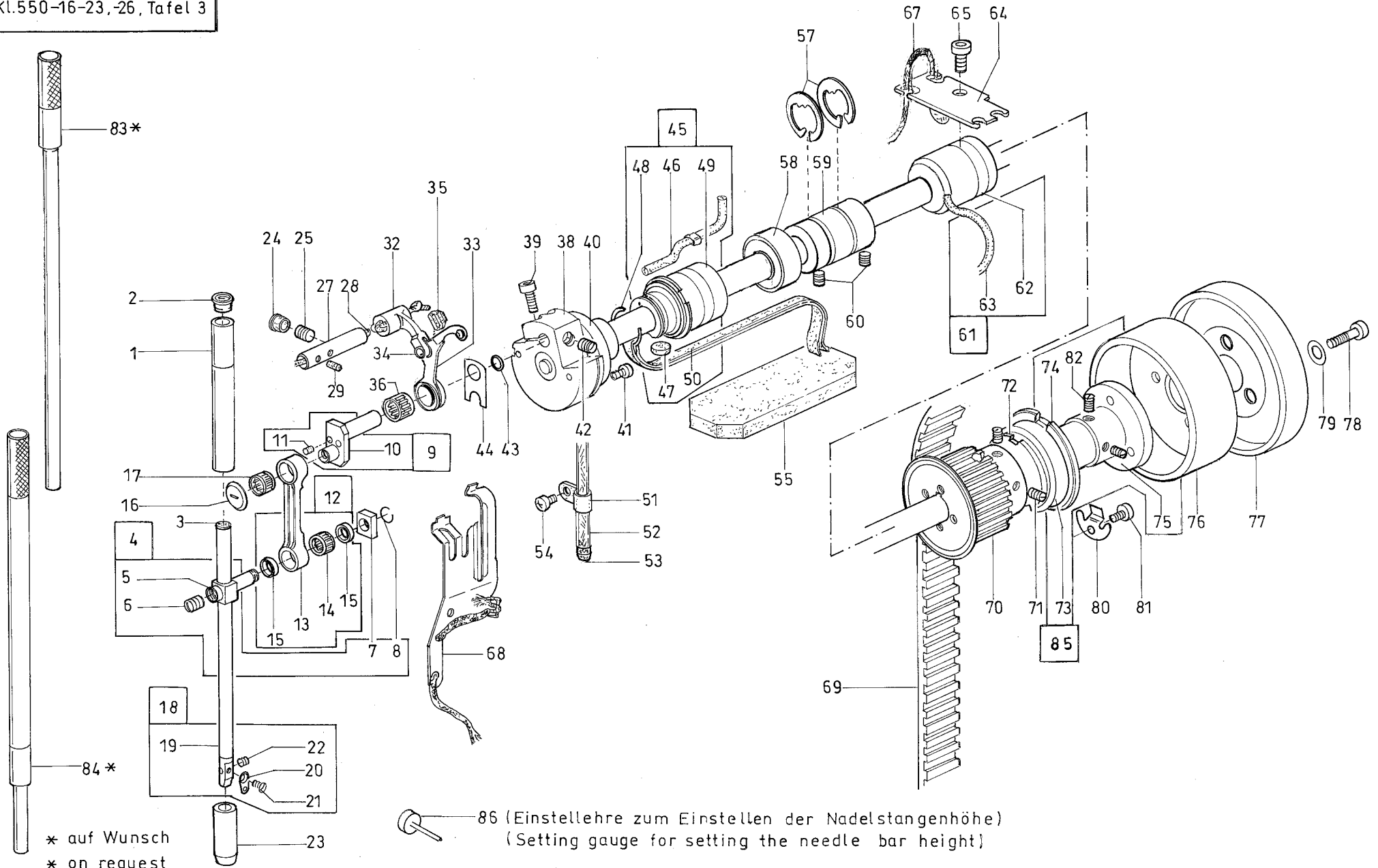

Pos.	Teile-Nr. / Part no.	Benennung	Denomination
		OBERTEIL	MACHINE HEAD
1	0211 000376	Nadelstg. Buchse	needle bar bush
2	1001 001162	Stopfen	plug
3	0570 010007	Gummistopfen	rubber plug
4	0212 000151	Kreuzkopf K	cross head cpl.
4		(Mit Pos. 5-8)	(with pos. 5-8)
5	0211 000152	Kreuzkopf	cross hesd
6	0223 000646	Gew. Stift	threaded stud
7	0211 000394	Gleitstein	slide block
8	0211 000395	Sprengring	spring ring
9	0271 000095	Kurbelzapfen K	crank pin cpl.
9		Kurbelzapfen K (Mit Pos. 10,11)	(with pos. 10,11)
10	0271 000096	Kurbelzapfen	crank pin
11	0002 008308 3325	Rundfilz	felt
12	0211 000390 K	Nadelzugstange K	needle draw bar cpl.
12		(Mit Pos. 13-15)	(with pos. 13-15)
13	0211 000390 A	Nadelzugstange	needle draw bar
14	0211 000208	Nadelkranz	needle bearing
15	0211 000391 A	Scheibe	washer
16	0211 000398	Schraube	screw
17	0211 000397	Nadelkranz	needle bearing
18	0211 000339	Nadelstange K	needle bar cpl.
18		(Mit Pos. 19-22)	(with pos. 19-22)
19	0271 120133	Nadelstange V	needle bar
20	0291 000159	Fadenfuehrung	thread guide
21	9203 312411	Senkschr.	countersunk screw
22	0556 000148	Gew. Stift	threaded stud
23	6279 130150	Nadelst. Buchse	needle bar bush
24	0271 000029	Schutzstopfen	cap
25	9205 102478	Gew. Stift	threaded stud
27	0211 000412 A	Fadenhebel Achse	thread lever shaft
28	9041 100030	Oeldocht, rund	oil wick
29	9041 102025	Rundfilz	felt
32	0211 000405	Fadenhebel Gelenk	thread articulation
33	0271 001069	Fadenhebel V	thread lever

Pos.	Teile-Nr. / Part no.	Benennung	Denomination
34	0211 000406	Nadelrolle	needle
35	0271 000119	Manschette	packing
36	0211 000408	Nadelkranz	needle bearing
38	0271 001064	Armwelle V	arm shaft
39	9202 002488	Zyl. Schr.	cyl. screw
40	0211 000332	Ring	ring
41	9203 003653	Zyl. Schr.	cyl. screw
42	0223 000646	Gew. Stift	threaded stud
43	0211 000331	Runddichtring	rubber ring
44	0211 000407	Anlageplatte	distance plate
45	0271 000014	Armlager K	arm bearing cpl.
45		(Mit Pos. 46-50)	(with pos. 46-50)
46	0271 000026	Runddocht	oil wick
47	0211 000305 A	Filzteil	felt
48	0212 000016 B	Federring	spring ring
49	0211 000302 B	Armlager V	arm bearing
50	0002 005889 0700	Flachdocht	oil wick
51	9840 120026	Bef. Schelle	clip
52	0002 008930 0070	Oelschlauch	oil hose
53	0999 220752	Filtereinsatz	filter
54	9204 201648	Linsenschr.	fillister head screw
55	0211 000299	Filzteil	felt
57	9352 500070	Sich. Ring	lock ring
58	9122 200150	Nadelhuelse	needle bush
59	0271 130140	Exzenter	eccentric
60	0570 000055	Gew. Stift	threaded stud
61	0211 000316	Armlager K	arm bearing cpl.
61		(Mit Pos. 62,63)	(with pos. 62,63)
62	0211 000317	Armlager	arm bearing
63	9041 100050	Oeldocht	oil wick
64	0271 000054	Lasche	shackle
65	9204 201668	Linsenschr.	fillister head screw
67	9041 100203	Baumwolldocht	oli wick
68	0271 380034	Oelfangblech	oil plate
69	9130 221052	Zahnriemen	toothed belt
70	6279 350030	Zahnriemenrad	toothed belt wheel
71	9205 102473	Gew. Stift	threaded stud

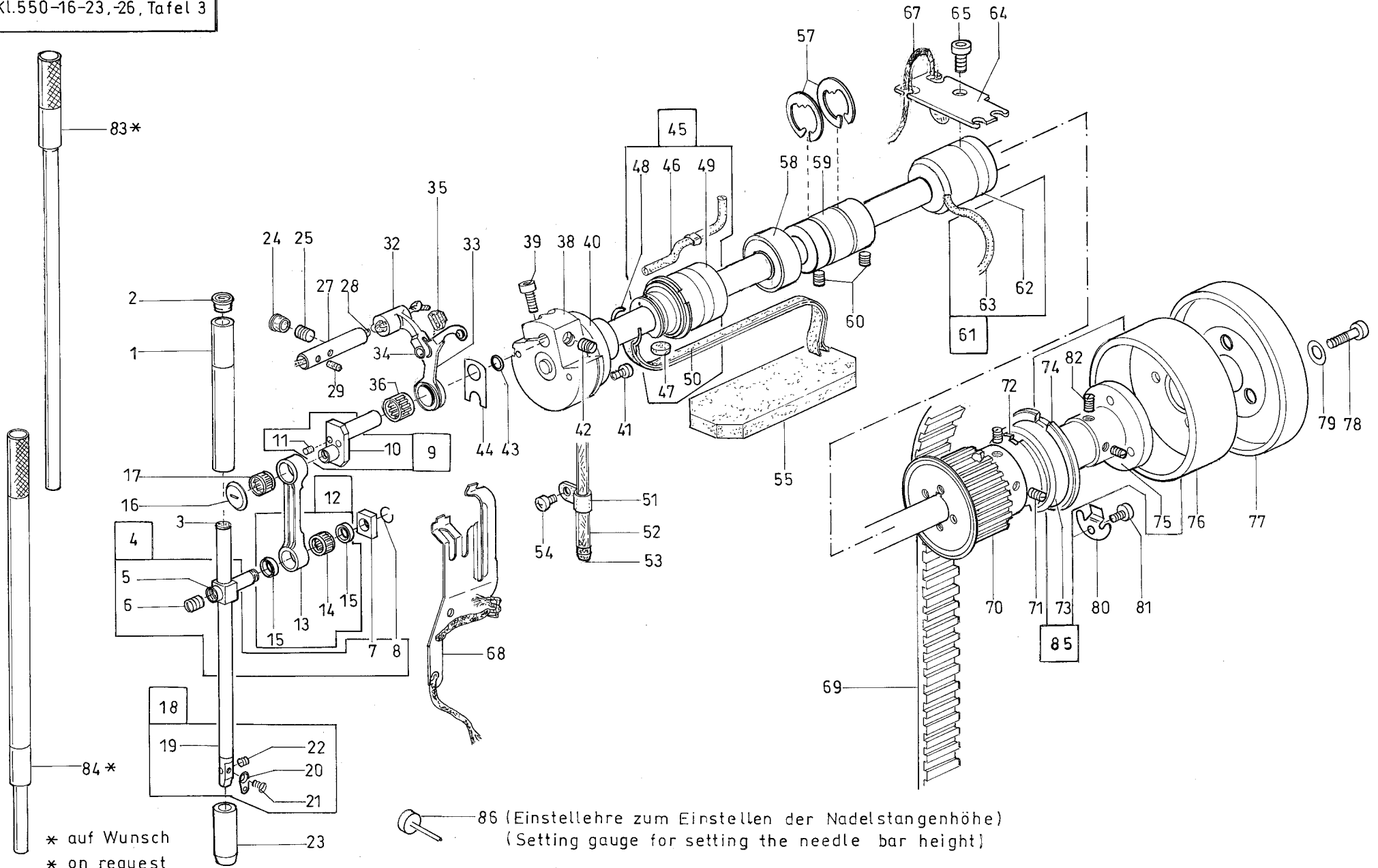

Pos.	Teile-Nr. / Part no.	Benennung	Denomination
72	0271 000072	Einstellring	setting ring
73	9120 080250	Rillenkugellager	ball bearing
74	9129 016060	Sprengring	spring ring
75	6279 100020	Flansch	flange
76	6279 100050	Topf	cover
77	0271 000100	Handrad	hand wheel
78	9204 201977	Linsenschr.	fillister head screw
79	0791 001093 A	Scheibe	washer
80	0933 000075	Haltefeder	locking spring
81	9204 201648	Linsenschr.	fillister head screw
82	9205 102473	Gew. Stift	threaded stud
83	0271 000316	Montagedorn zu Pos. 1	assembling jig. to pos. 1
84	0271 000318	Montagedorn zu Pos. 23	assembling jig. to pos. 23
85	6279 100054	Flansch K.	flange cpl.
85		(Mit Pos. 73-75, 82)	(with pos. 73-75, 82)
86	6279 290010	Einstellehre	setting gauge

Pos.	Teile-Nr. / Part no.	Benennung	Denomination
------	----------------------	-----------	--------------

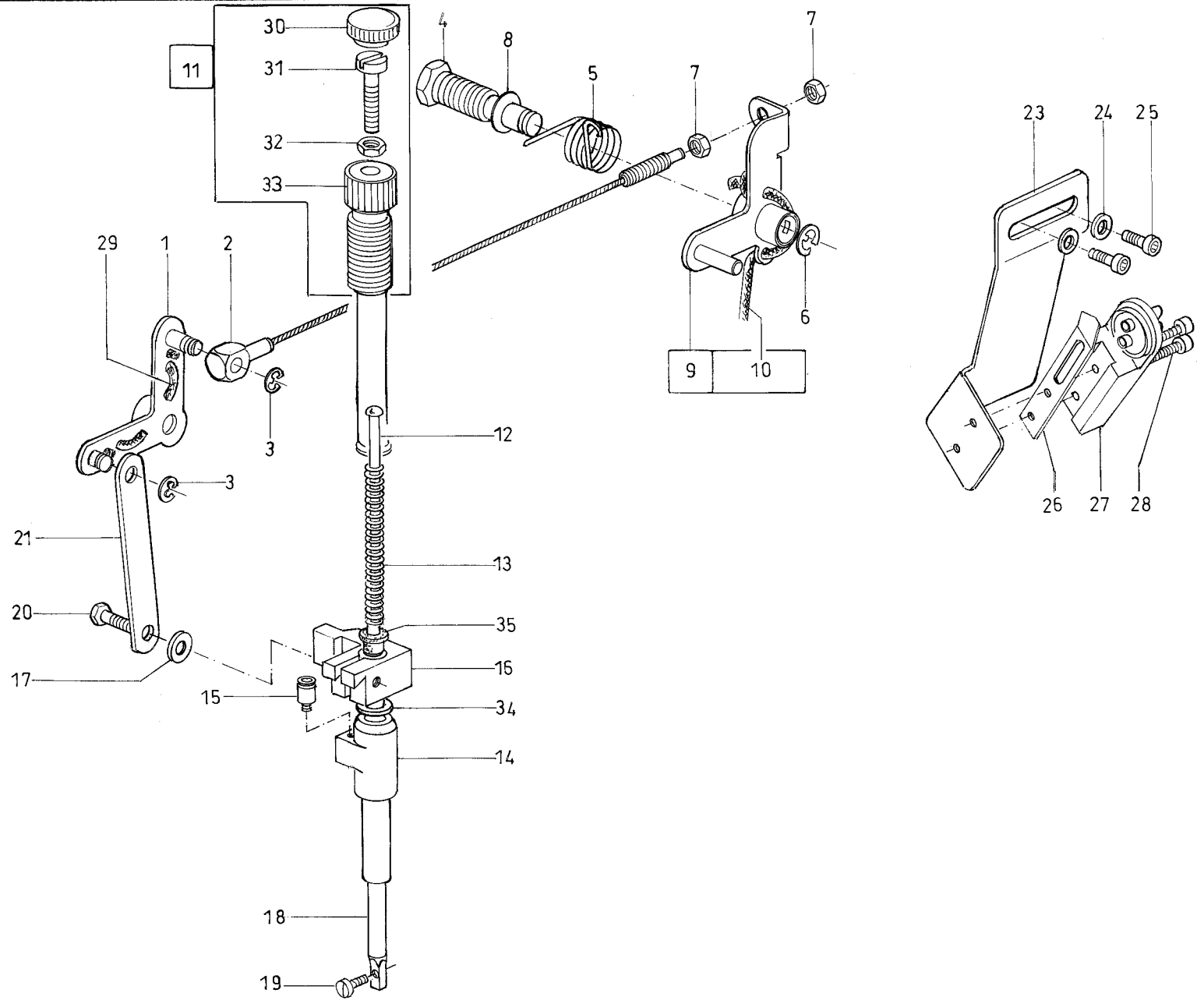

Pos.	Teile-Nr. / Part no.	Benennung	Denomination
		OBERTEIL	MACHINE HEAD
1	6279 130253	Winkelhebel V	bent lever
2	6279 130123	Zugseil V	draw
3	9357 000060	Sich. Scheibe	lock washer
4	6279 130040	Bolzen	bolt
5	0271 130130	Drehfeder	torsion spring
6	9352 000080	Sich. Ring	lock ring
7	9231 000368	6Kt. Mutter	hexagonal nut
8	0998 881080	Scheibe	washer
9	6279 130093	Winkelhebel	bent lever
9		(Mit Pos. 10)	(with pos. 10))
10	9041 100025	Oeldocht	oil wick
11	6279 130144	Regulierbuchse K.	adjustment bush cpl.
11		(Mit Pos. 30-33)	(with pos. 30-33)
12	0211 000440	Halbrd. Niet	bolt
13	0211 000439	Druckfeder	pressure spring
14	9700 100033	Zylinder, einf.	cylinder
15	9790 200000	Verschr. Gd.-E	coupling
16	6279 130070	Luefterkloben	lifting block
17	9334 102110	Scheibe	washer
18	0211 000438	Stoffstange	cloth bar
19	9202 002073	Zyl. Schr.	cyl. screw
20	0271 130030	Ansatzschr.	shoulder screw
21	6279 130080	Zugstange	draw bar
23	6279 130200	Winkel	angle
24	9330 000088	Scheibe	washer
25	9202 002073	Zyl. Schr.	cyl screw
26	6279 130210	Blattfeder	spring
27	0933 001544	Pumpe K	pump cpl.
28	9203 100631	Flachkopfschr.	filister head screw
29	9041 100025	Oeldocht	oil wick
30	9400 100009	Raendelschr. Kopf	knurled screw head
31	9202 002497	Zyl. Schr.	cyl. screw
32	9231 110107	6Kt. Mutter	hexagonal nut
34	0558 010052	Scheibe	washer

Pos.	Teile-Nr. / Part no.	Benennung	Denomination
35	0271 000165	Stopfen	plug

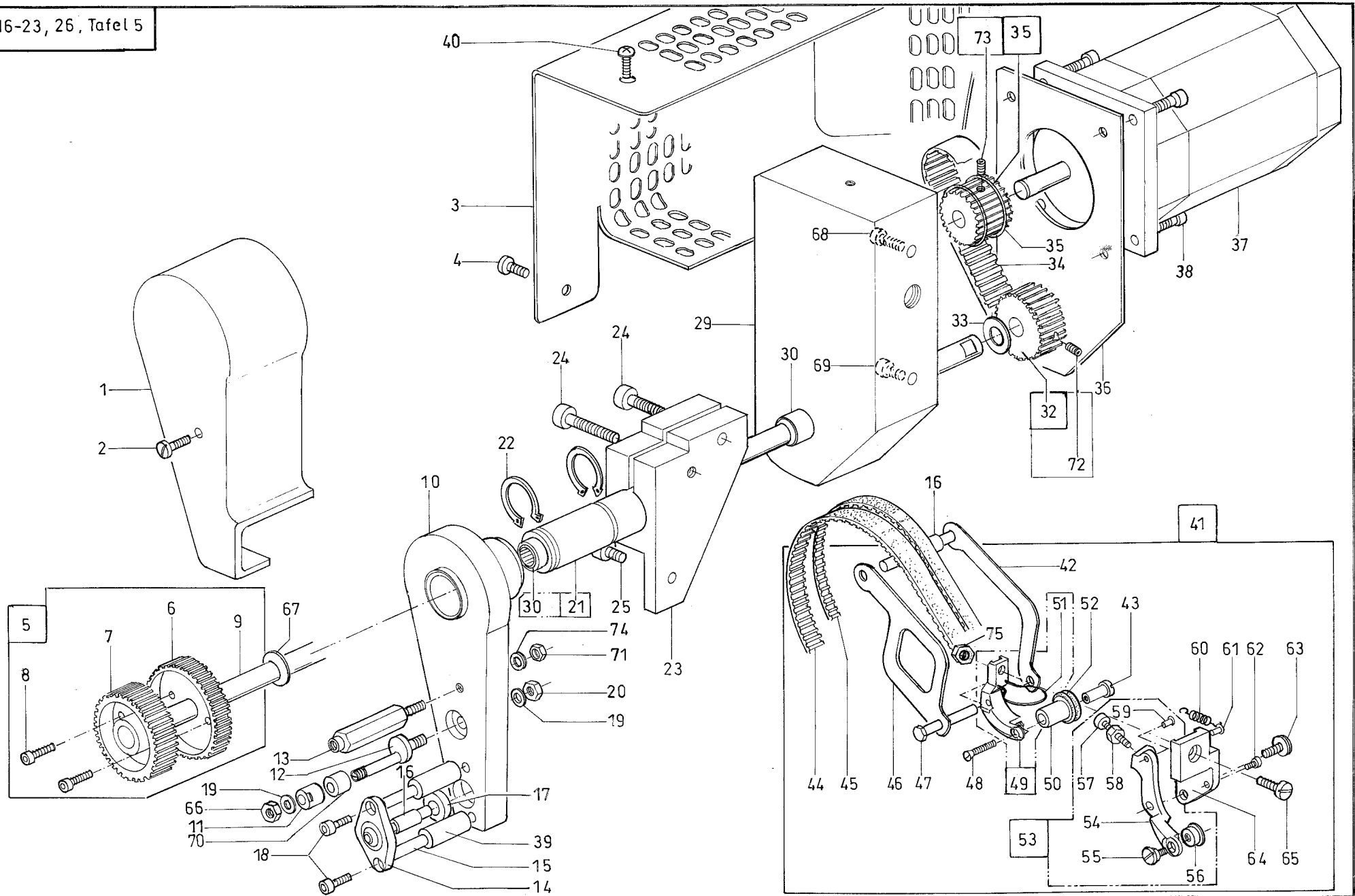

Pos.	Teile-Nr. / Part no.	Benennung	Denomination
		OBERTEIL	MACHINE HEAD
1	6279 340440	Kappe	cap
2	0219 000353	Linsenschr.	screw
3	6279 340360	Kappe	cap
4	9204 101658	Li. Zyl. Schraube	fillister head screw
5	6279 340183	Zahnriemenrad V	belt pulley
5		(Mit Pos. 6 - 9)	(with pos. 6 - 9)
6	6279 340190	Zahnriemenrad	belt pulley
7	6279 340200	Zahnriemenrad	belt pulley
8	9202 002068	Zyl. Schraube	cyl. screw
9	6279 340210	Welle	shaft
10	6279 340543	Lagerplatte (bis 10.2000)	bearing plate (up to 10.2000)
10	6279 340283	Lagerplatte (ab 11.2000)	bearing plate (from 11.2000)
11	6279 340510	Spannstueck	falter
12	6279 340520	Exz. Bolzen	excentric bolt
13	6279 340350	Distanzbolzen	spacer bolt
14	6279 340553	Lasche V (bis10.2000)	shackle cpl. (up to 10.2000)
14	6279 340333	Lasche V (ab 11.2000)	shackle cpl. (from 11.2000)
15	6279 340320	Bolzen	bolt
16	6279 340340	Bolzen	bolt
17	0999 210569	Gelenklager	bearing
18	9202 001658	Zyl. Schraube	cyl. screw
19	9330 000098	Scheibe	washer
20	9231 110108	6Kt. Mutter	hexagonal nut
21	6279 340153	Huelse	bush
21		(Mit Pos. 30)	(with pos. 30)
22	9352 000180	Sich. Ring	circlip
23	6279 340220	Bock	block
24	9202 002508	Zyl. Schraube	cyl. screw
25	9202 002488	Zyl. Schraube	cyl. screw
29	6279 340134	Halter	holder
30	0744 001369	Nadelhuelse	needle bush
32	6279 340633	Zahnriemenrad V	belt pulley cpl.
32		(Mit Pos. 72)	(with pos. 72)
33	0998 881080	Paszscheibe	adjusting washer

Pos.	Teile-Nr. / Part no.	Benennung	Denomination
34	9130 244200	Zahnriemen	toothed belt
35	6279 340623	Zahnriemenrad V	belt pulley cpl.
35		(Mit Pos. 73)	(with pos. 73)
36	6279 340140	Deckel	cover
37	9800 580011	Motor, Schritt	motor
38	9202 002093	Zyl. Schraube	cyl. screw
39	6279 340530	Gleitstueck	slide part
40	9204 101658	Linsenschraube	screw
41	6279 220014	Drueckerfuss K.	presser foot cpl.
41		(Mit Pos. 42 - 53, 60 - 66, 75)	(with pos. 42 - 53, 60 - 66, 75)
42	6279 220020	Hebel	lever
43	0396 222530	Ansatzbolzen	bolt
44	9130 240010	Zahnriemen (bis 05. 2009)	toothed belt (up to 05. 2009)
44	9130 240070	Zahnriemen (ab 06. 2009)	toothed belt (from 06. 2009)
45	0396 342880	Zahnriemen (bis 10. 2000)	toothed belt (up to 10.2000)
45	9130 240060	Zahnriemen (ab 06. 2009)	toothed belt (from 06. 2009)
45	9130 240400	Zahnriemen (11.00 - 05.09)	toothed belt (11.00 - 05.09)
46	6279 220040	Hebel	lever
47	6279 220050	Achse	shaft
48	9203 312451	Senkschr.	countersunk screw
49	6279 220013	Drueckerfuss	presser foot
49		(Mit Pos. 51)	(with pos. 51)
50	0568 220440	Rolle	roller
51	0568 220140	Fingerschutz	finger protection
52	0998 860280	0-Ring	0-ring
53	6279 220073	Rollenhebel V	roller lever cpl.
53		(Mit Pos. 54 - 59)	(with pos. 54 - 59)
54	6279 220070	Rollenhebel	roller lever
55	6279 220090	Rolle	roller
56	6279 220080	Rolle	roller
57	9202 001698	Zyl. Schr.	cyl. screw
58	9231 110038	6Kt. Mutter	hexagonal nut
59	9303 700607	Halbrd. Kb. Nagel	nail
60	0170 150610	Zugfeder	spring
61	9303 700607	Halbrd. Kb. Nagel	nail
62	9203 001808	Zyl. Schr.	cyl. screw
63	0992 023677	Li. Zyl. Schr.	screw

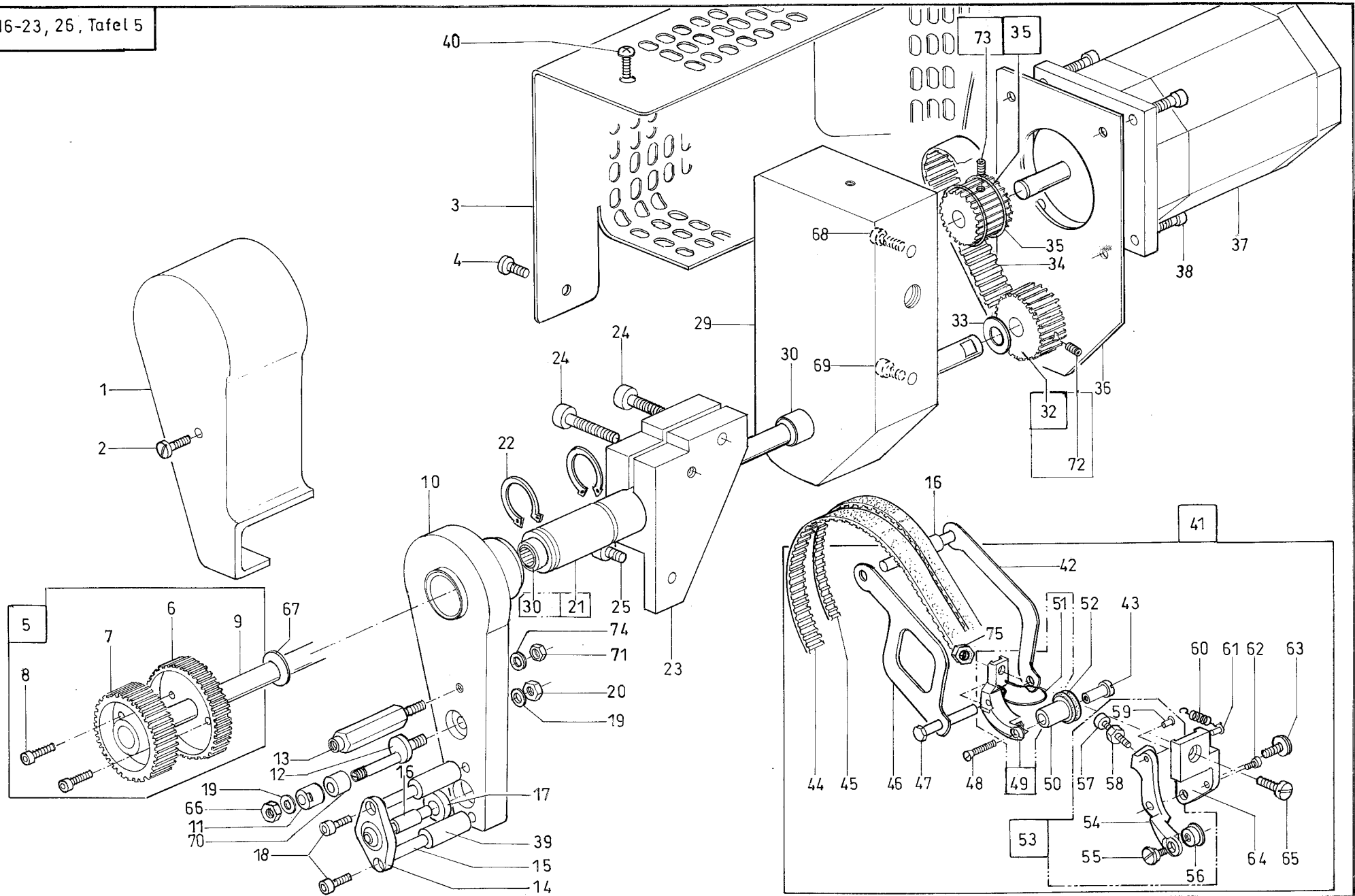

Pos.	Teile-Nr. / Part no.	Benennung	Denomination
64	6279 220030	Fuss Oberteil	foot part
65	9202 002073	Zyl. Schr.	cyl. screw
66	9231 000377	6Kt. Mutter	hexagonal nut
67	0998 882080	Paszscheibe	adjusting washer
68	9202 002508	Zyl. Schr.	cyl. screw
69	9202 002488	Zyl. Schr.	cyl. screw
70	6279 340530	Gleitstueck	sliding block
71	9231 110058	6Kt. Mutter	hexagonal nut
72	0271 000756	Gew. Stift	threaded pin
73	9205 102143	Gew. Stift	threaded pin
74	9330 000088	Scheibe	washer
75	9231 110053	6Kt. Mutter	hexagonal nut

Pos.	Teile-Nr. / Part no.	Benennung	Denomination
------	----------------------	-----------	--------------

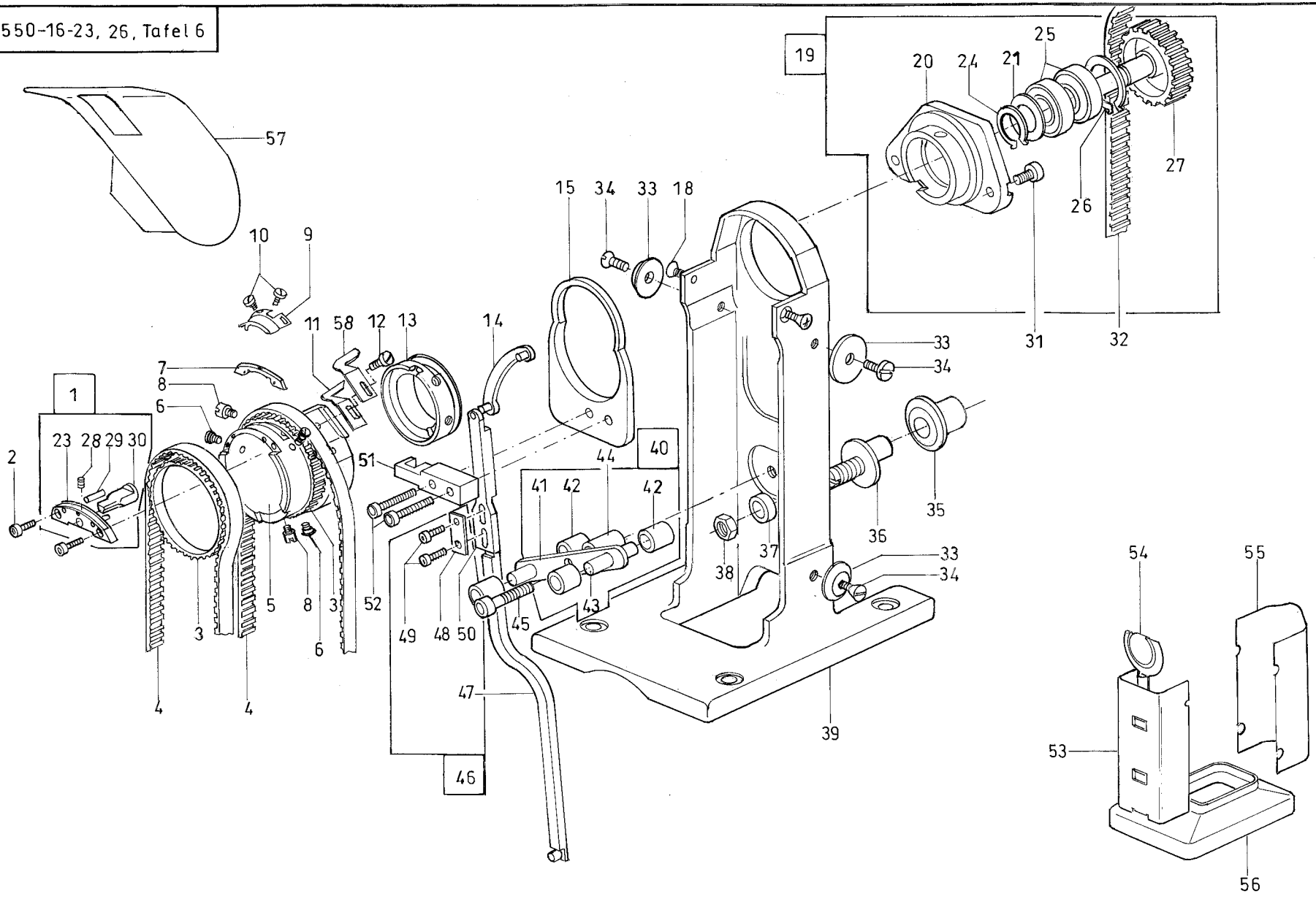

Pos.	Teile-Nr. / Part no.	Benennung	Denomination
		SAEULENKOPF K.	HEAD FOR PILLAR CPL.
1	0568 140713	Fuehrungsstueck V (Mit Pos. 23, 28 - 30)	guide block cpl. (with pos. 23, 28 - 30)
2	9202 001658	Zyl. Schr.	cyl. screw
3	0568 341130	Zahnkranz	tooth pointing
4	0568 340570	Zahnriemen (bis 05.2009)	toothed belt (up to 05.2009)
4	9130 240050	Zahnriemen (ab 06.2009)	toothed belt (from 06.2009)
5	0568 140690	Saeulenkopf	head for pillar
6	0742 055716	Senkschr.	countersunk screw
8	9203 401870	Zapfenschr.	screw
7	0568 200320	Stichplatte	throat plate
9	0568 350360	Fadenz. Messer	thread knife
10	9203 003042	Zyl. Schr.	cyl. screw
11	0568 350370	Gegenmesser	counter - knife
12	0992 024358	Zyl. Schr.	cyl. screw
13	0568 350340	Lagerring	bearing ring
14	0396 350400	Gelenk	articulation
15	6279 350090	Halter	holder
18	9225 201750	Senkschr.	countersunk screw
19	6279 150014	Greiferlager K.	hook bearing cpl.
19		(Mit Pos. 20 ,21,24-27)	(with pos. 20 ,21,24-27)
20	6279 150010	Greiferlager	hook bearing
21	0998 880580	Paszseibe (0,1)	washer (0,1)
21	9099 888255 0	Paszscheibe (0,2)	washer (0,2)
23	0568 140710	Fuehrungsstueck	guide block
24	9352 000080	Sich. Ring	circlip
25	9120 030084	Rillenkugellager	bearing
26	0212 004786	Sich. Ring	circlip
27	6279 150023	Greiferw. Rad V.	hook shaft wheel
28	9205 101848	Gew. Stift	threaded stud
29	9301 100981	Zyl. Stift	cyl. stud
30	0568 150710	Mittelteiler	middle piece holder
31	9202 042477	Zyl. Schr.	cyl. screw
32	0568 150150	Zahnriemen	toothed belt
33	0971 411950	Scheibe	washer

Pos.	Teile-Nr. / Part no.	Benennung	Denomination
34	9203 123682	Zyl. Schr.	cyl. screw
35	0568 150700	Rolle	pulley
36	0568 150660	Exz. Bolzen	eccentric bolt
37	9330 000127	Scheibe	washer
38	9231 110137	6Kt. Mutter	hexagonal nut
39	0568 140600	Saeule	pillar
40	6279 340244	Spanner K.	falter cpl.
40		(Mit Pos. 41 - 43)	(with pos. 41 - 43)
41	6279 340240	Spanner	falter
42	0568 340940	Gleitstueck	sliding block
43	9301 102211	Zyl. Stift	cyl. pin
44	6279 340260	Huelse	bush
45	9202 002527	Zyl. Schr.	cyl. screw
46	0568 350394	Zugstange K.	traction rod cpl.
46		(Mit Pos. 47 - 50)	(with pos. 47 - 50)
47	0568 350383	Zugst. Unterteil V.	traction rod underpart cpl.
48	0568 350310	Lasche	shackle
49	9202 001658	Zyl. Schr.	cyl. screw
50	0568 350280	Zugst. Oberteil	traction rod overpart
51	6279 350100	Zugst. Fuehrung	traction rod guide
52	9202 002093	Zyl. Schr.	cyl. screw
53	6279 140060	Abdeckkappe	cap
54	6279 140050	Deckel	cap
55	0568 140642	Abdeckkappe	cap
56	6279 140030	Kappe	cap
57	6279 140093	Auflage	rest
58	6279 350140	Deckblech	cover plate

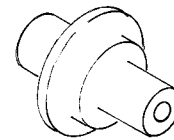
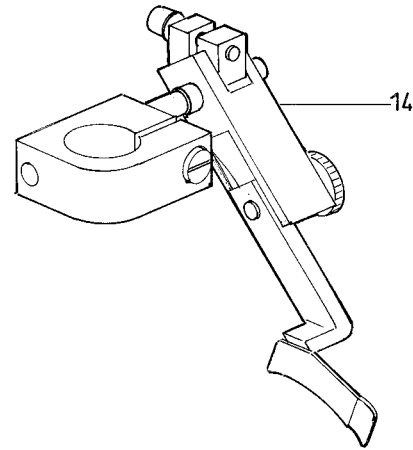
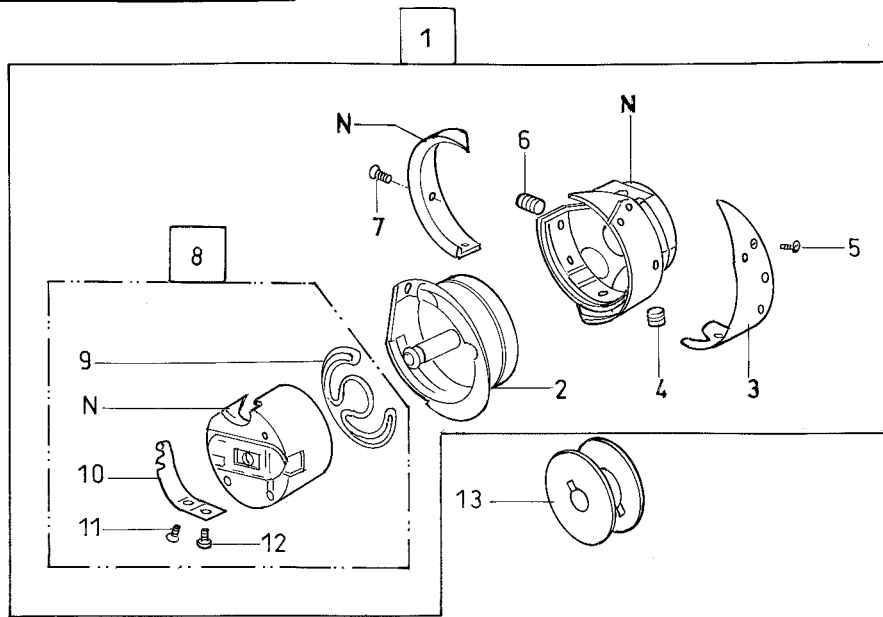

15 (Einstellehre zur Zentrierung der Greiferlager-
achse)
(Setting gauge for centering the hook shaft)

N— nicht als Einzelteil lieferbar
not available as separate part

Pos.	Teile-Nr. / Part no.	Benennung	Denomination
		GREIFER	HOOK
1	0271 150034	Greifer K.	hook cpl.
1		(Mit Pos. 2 - 8)	(with pos. 2 - 8)
2	0271 150040	Spgh. Unterteil	bobbin winder frame part
3	0271 000759	Fadenz. Blech	threaded pulling sheet
4	0271 000756	Gew. Stift	threaded stud
5	0271 150090	Senkschraube	countersunk screw
7	0271 150080	Senkschraube	countersunk screw
8	0271 150054	Spgh. Oberteil	bobbin case upper part
8		(Mit Pos. 9 - 12)	(with pos. 9 - 12)
9	0271 150060	Bremsfeder	brake spring
10	0211 001127	Spannungsfeder	tension spring
11	0271 150070	Senkschraube	countersunk screw
12	0211 001129	Zyl. Schraube	cyl. screw
13	0204 000230 A	Spule (Alu)	bobbin
14	N800 045144	Kantenanschlag	edge guide
15	6279 290020	Einstellehre	setting gauge

Pos.	Teile-Nr. / Part no.	Benennung	Denomination
------	----------------------	-----------	--------------

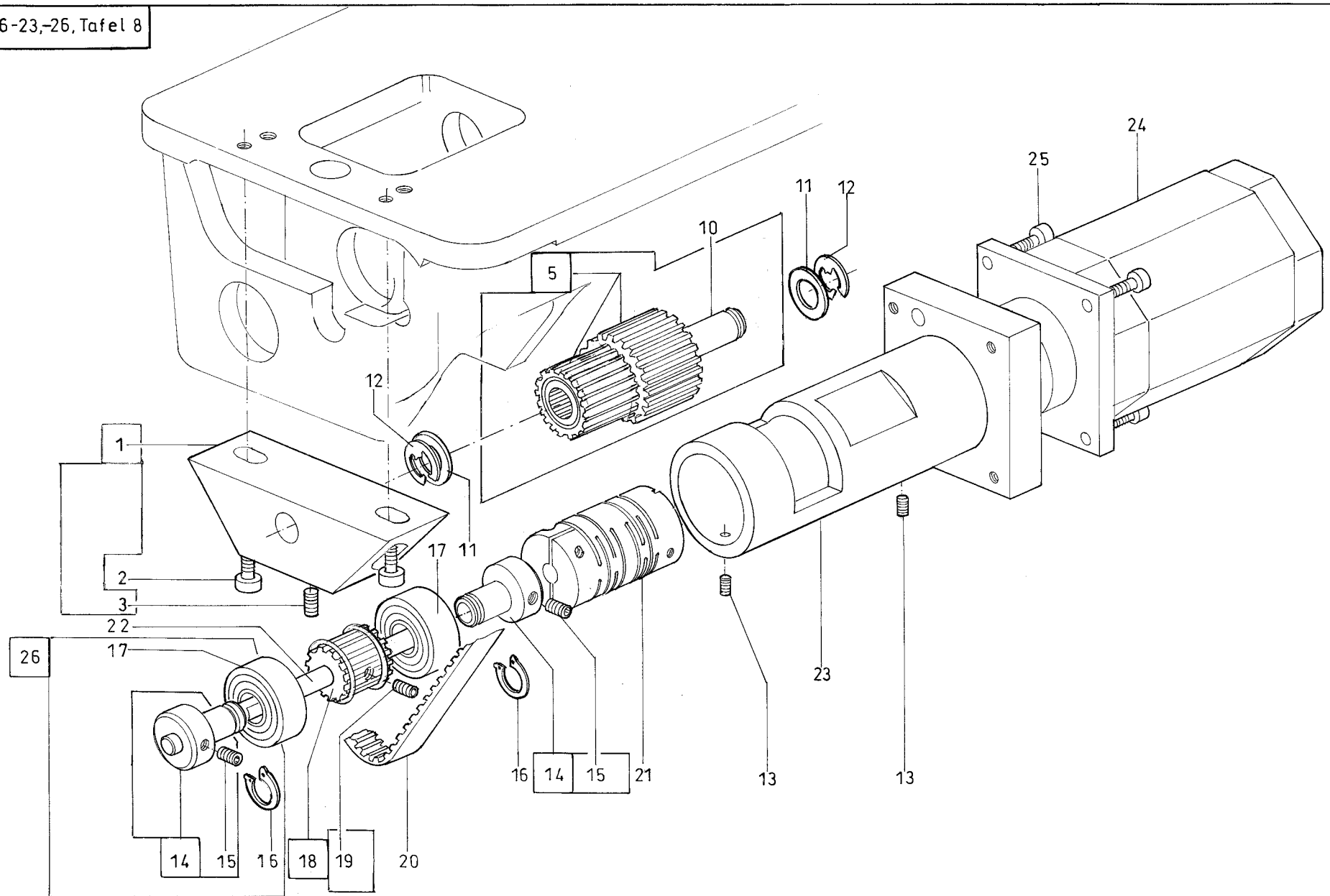

Pos.	Teile-Nr. / Part no.	Benennung	Denomination
		OBERTEIL	MACHINE HEAD
1	6279 340083	Bock	bracket
1		(Mit Pos. 3)	(with pos. 3)
2	9202 002888	Zyl. Schraube	cyl. screw
3	9205 102188	Gew. Stift	threaded pin
5	6279 340603	Zahnriemenrad K.	belt pulley cpl.
10	6279 340070	Welle	shaft
11	0998 881610	Paszscheibe	adjusting washer
12	9352 000120	Sich. Ring	circlip
13	9205 102188	Gew. Stift	threaded pin
14	6279 340023	Lagerhuelse V	bearing sleeve
14		(Mit Pos. 15)	(with pos. 15)
15	0271 000756	Gew. Stift	threaded pin
16	9352 000120	Sich. Ring	circlip
17	9120 030121	Rillenkugellager	grooved ball bearing
18	6279 340613	Zahnriemenrad V	belt pulley cpl.
18		(Mit Pos. 19)	(with pos. 19)
19	9205 102143	Gew. Stift	threaded pin
20	9130 244201	Zahnriemen	toothed belt
21	9110 000010	Kupplung	coupler
22	6279 340030	Welle	shaft
23	6279 340010	Huelse	bush
24	9800 580011	Motor, Schritt	motor
25	9202 002097	Zyl. Schraube	cyl. screw
26	6279 340024	Lagerhuelse K.	bearing sleeve cpl.
26		(Mit Pos. 14,16,17)	(with pos. 14,16,17)

Pos.	Teile-Nr. / Part no.	Benennung	Denomination
------	----------------------	-----------	--------------

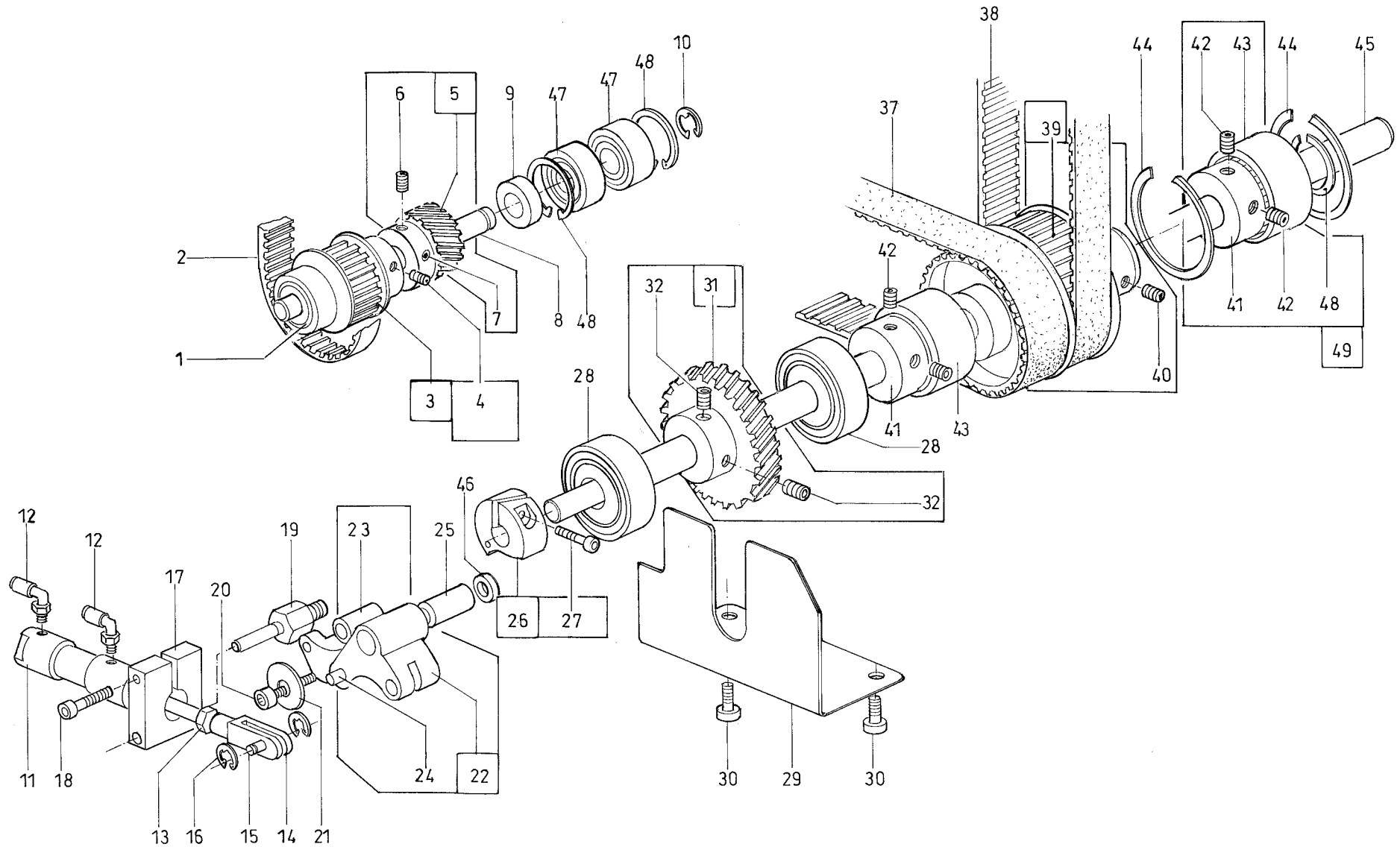

Pos.	Teile-Nr. / Part no.	Benennung	Denomination
		OBERTEIL	MACHINE HEAD
1	9120 030081	Rillenkugellager	ball bearing
2	0568 150150	Zahnriemen	thooted belt
3	6279 150053	Zahmriemenrad V	bellt pulley cpl.
3		(Mit Pos. 4)	(with pos. 4)
4	0556 005040	Gew. Stift	threaded pin
5	0211 000018	Zahnrad V	cog weehl cpl.
5		(Mit Pos. 6, 7)	(with pos. 6, 7)
6	0223 000237	Gew. Stift	threaded pin
7	0223 000238	Gew. Stift	threaded pin
8	6279 150040	Welle	shaft
9	6279 350070	Scheibe	washer
10	9352 000080	Sich. Ring	circlip
11	0999 220756	Zylinder, Doppel	cylinder
12	9790 201000	Verschr. Wi.- E	coupling
13	9231 000378	6Kt. Mutter	hexagonal nut
14	0396 351730	Gabelkopf	fork head
15	0504 330920	Bolzen	bolt
16	9357 000050	Sich. Scheibe	locking washer
17	0396 351680	Lagerbock	fit bracket
18	9202 002097	Zyl. Schraube	cyl. screw
19	6279 350060	Zapfen	stud
20	9202 002937	Zyl. Schraube	cyl. screw
22	0396 351713	Antr. Segment V	driving segment cpl.
22		(Mit Pos. 23, 24)	(with pos. 23, 24)
23	0396 351720	Rolle	roller
24	9301 101611	Zyl. Stift	cyl. pin
25	0396 350660	Huelse	bush
26	6279 350083	Steuerkurve V	control cam cpl.
26		(Mit Pos. 27)	(with pos. 27)
27	9202 002073	Zyl. Schr.	cyl. screw
28	9120 030121	Rillenkugellager	ball bearing
29	6279 340390	Schutzblech	guard plate
30	9202 002063	Zyl. Schraube	cyl. screw
31	0216 000070	Zahnrad V	tooth wheel

Pos.	Teile-Nr. / Part no.	Benennung	Denomination
31		(Mit Pos. 32)	(with pos. 32)
32	0244 000700	Gew. Stift	threaded pin
37	9130 221051	Zahnriemen	toothed belt
38	9130 221052	Zahnriemen	toothed belt
39	6279 350023	Zahnriemenrad V	bellt pulley
39		(Mit Pos. 40)	(with pos. 40)
40	9205 102473	Gew. Stift	threaded stud
41	0271 140070	Lagerhuelse	bearing sleeve
42	9205 102473	Gew. Stift	threaded pin
43	9120 030151	Rillenkugellager	ball bearing
44	0744 020505	Sich. Ring	circlip
45	6279 350010	Welle	shaft
46	6279 350050	Scheibe	washer
47	0211 000025	Rillenkugellager	ball bearing
48	9352 000150	Sich. Ring	circlip
49	6279 140164	Lagerhuelse K.	bearing sleeve cpl.
49		(Mit Pos. 41-43, 48)	(with pos. 41-43, 48)

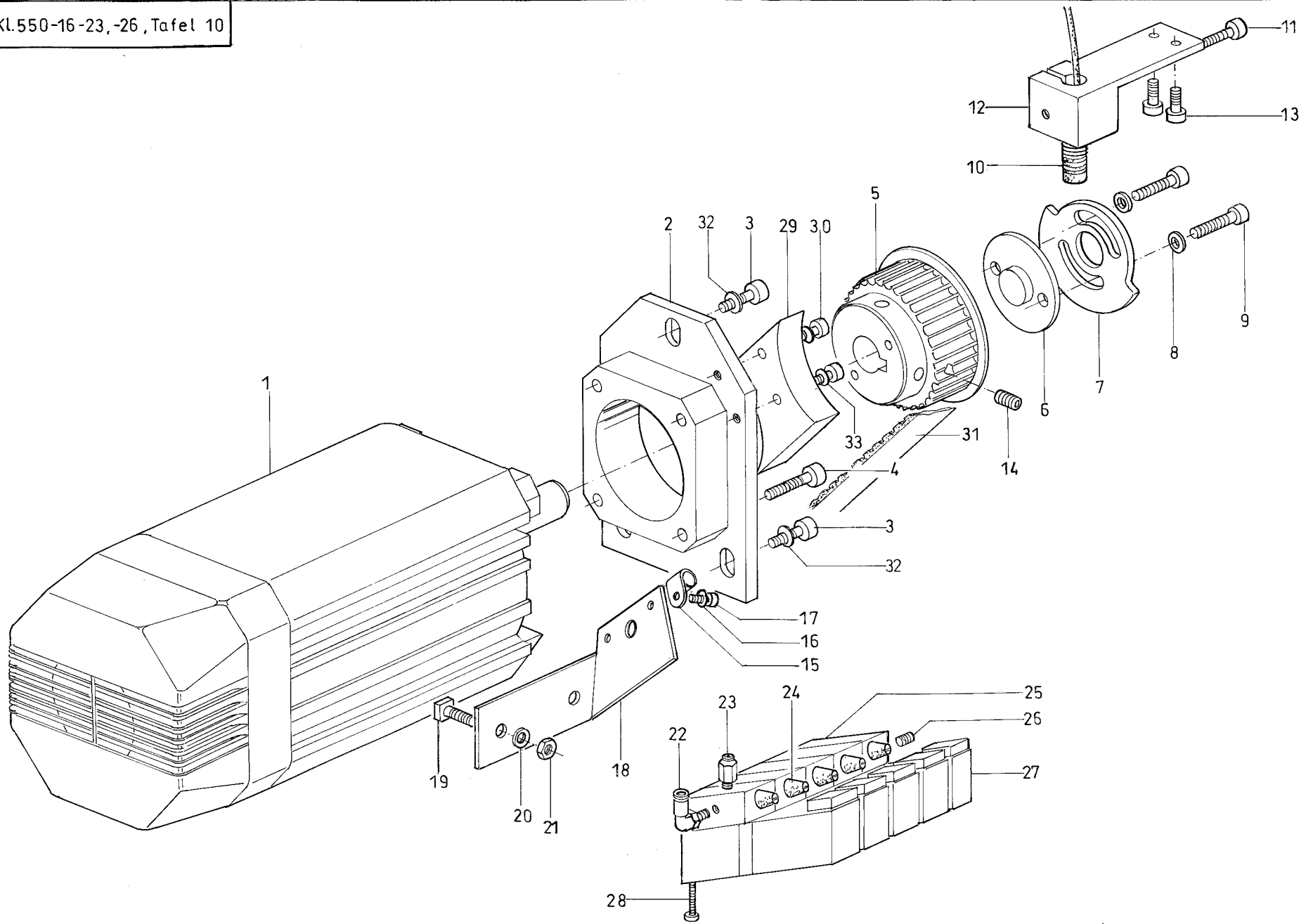

Pos.	Teile-Nr. / Part no.	Benennung	Denomination
		NAEHANTRIEB	MOTOR
1	9800 130103	Naehantrieb (ohne Steuerkasten)	motor (without control box)
2	6279 340100	Platte	plate
3	9202 002498	Zyl. Schraube	cyl. screw
4	9202 002508	Zyl. Schraube	cyl. screw
5	6279 350030	Zahnriemenrad	belt pulley
6	6279 340420	Adapter	adapter
7	0935 150010	Kurvenscheibe	disc cam
8	9330 000098	Scheibe	washer
9	9202 002493	Zyl. Schraube	cyl. screw
10	9815 710203	Induktivgeber	proximity switch
11	9202 002093	Zyl. Schraube	cyl.screw
12	6279 340410	Klemmkloben	clamping block
13	9202 002063	Zyl. Schraube	cyl. screw
14	9205 102473	Gew. Stift	threaded stud
15	9840 120027	Bef. Schelle	clip
16	9330 000068	Scheibe	washer
17	9203 003042	Zyl. Schr.	cyl. screw
18	6279 340400	Halter	holder
19	9400 000138	4Kt. Schraube	screw
20	9330 000097	Scheibe	washer
21	9231 110108	6Kt. Mutter	hexagonal nut
22	9790 201000	Verschr. Wi - E	coupling
23	9790 200000	Verschr. Gd.- E	coupling
24	9710 982003	Schalldaempfer	sound absorber
25	9710 900035	Anschlussplatte	joining plate
26	0570 001847	Blindstopfen	plug
27	9710 061200	Ventil, Magnet	valve
28	9203 001917	Zyl. Schraube	cyl. screw
29	6279 340430	Riemenschutz	belt guard
30	9202 002388	Zyl. Schraube	cyl. screw
31	9130 221051	Zahnriemen	toothed belt
32	9330 000097	Scheibe	washer
33	9330 000088	Scheibe	washer

Pos.	Teile-Nr. / Part no.	Benennung	Denomination
------	----------------------	-----------	--------------

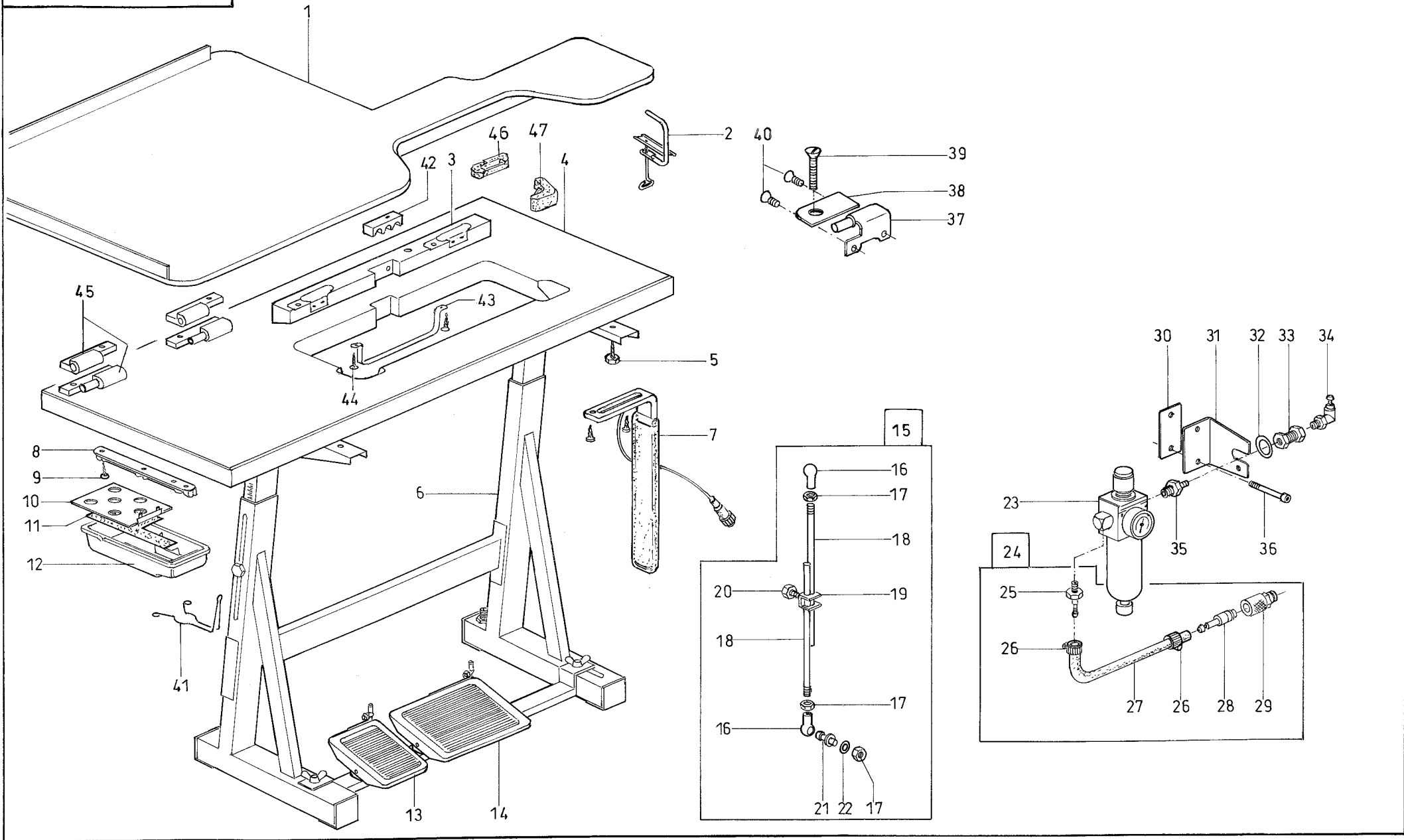

Pos.	Teile-Nr. / Part no.	Benennung	Denomination
		GESTELL	STAND
1	0568 250100	Anschiebetisch	table
2	0069 250060	Zwinge	clamp
3	0700 627902	Schraegauflage	rest
4	0700 627901	Tisch	table top
5	9206 200097	6Kt. Blechschraube	screw
6	MG55 000501	MG 55 - 3 Gestell	stand
7	9880 002002	Knieschalter K.	knee switch cpl.
8	0700 000044	Fuehrungsleiste	guide reglet
9	9207 170227	Spanpl. Schraube	screw
10	0700 000045	Platte	plate
11	0700 000050	Einlage	insert
12	0700 000043	Schubkasten	drawer
13	MG53 002521	Pedal K.	pedal cpl.
14	MG53 002501	Pedal K.	pedal cpl.
15	MG43 000451	Gestaenge K.	rods
16	9357 200106	Kugelpfanne	ball socket
17	9231 110127	6Kt. Mutter	hexagonal nut
18	0718 000254	Stange	bar
19	MG43 000403	Klemme	clamp
20	9201 250027	6Kt. Schraube	hexagonal nut
21	9357 200056	Kugelzapfen	ball stud
22	MG43 002150	Scheibe	washer
23	9780 000108	WE- Wartungseinheit K.	maintenance unit cpl.
24	0797 003031	Druckluftschlauch K.	hose cpl.
24		(Mit Pos. 25 - 29)	(with pos. 25 - 29)
25	9790 130010	Schlauchtuelle	socket
26	0742 002096	Schlauchklemme	hose clamp
27	9731 002001	Schlauch	hose
28	0744 001793 B	Kupplungsstecker	clutch clamp
29	0744 001793 A	Kupplungsdose	clutch
30	MG53 007922	Lasche	shackle
31	MG53 007921	Winkel	angle
32	9330 000167	Scheibe	washer
33	0999 240341	Doppelnippel	double nipple

Pos.	Teile-Nr. / Part no.	Benennung	Denomination
34	9790 111001	L - Verschraubung	l-coupling
35	0999 240303	Doppelnippel	double nipple
36	9207 170457	Spanpl. Schr.	screw
37	0239 000509	Scharnier	hinge
38	0700 000441	Halteblech	holding plate
39	9203 314637	Senkschr.	countersunk screw
40	9203 314257	Senkschr.	countersunk screw
41	MG43 000062	Klemme	clamp
42	6279 400070	Kabelfuehrung	cable clamp
43	6279 400030	Buegel	bow
44	9207 170847	Spanpl. Schr.	screw
45	9401 000021	Scharnier (links + rechts)	hinge (left + right)
46	0700 000056	Scharnierunterteil	hinge bottoms
47	0700 000092	Auflage	rest

Kl.550-16-23

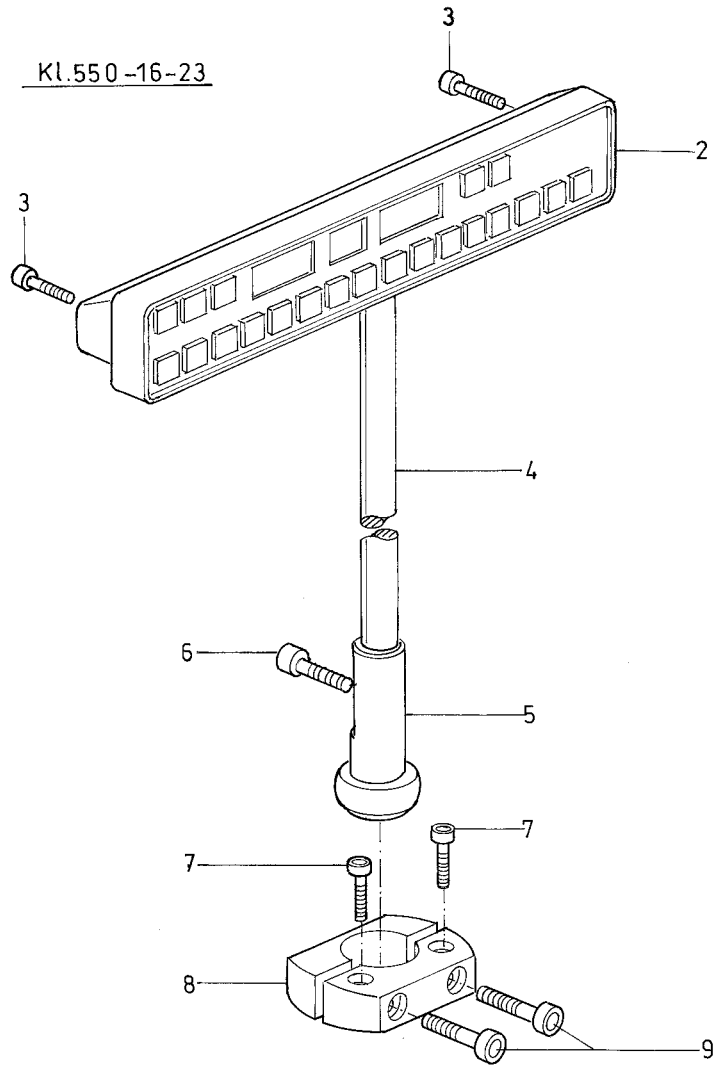

Kl.550-16-26

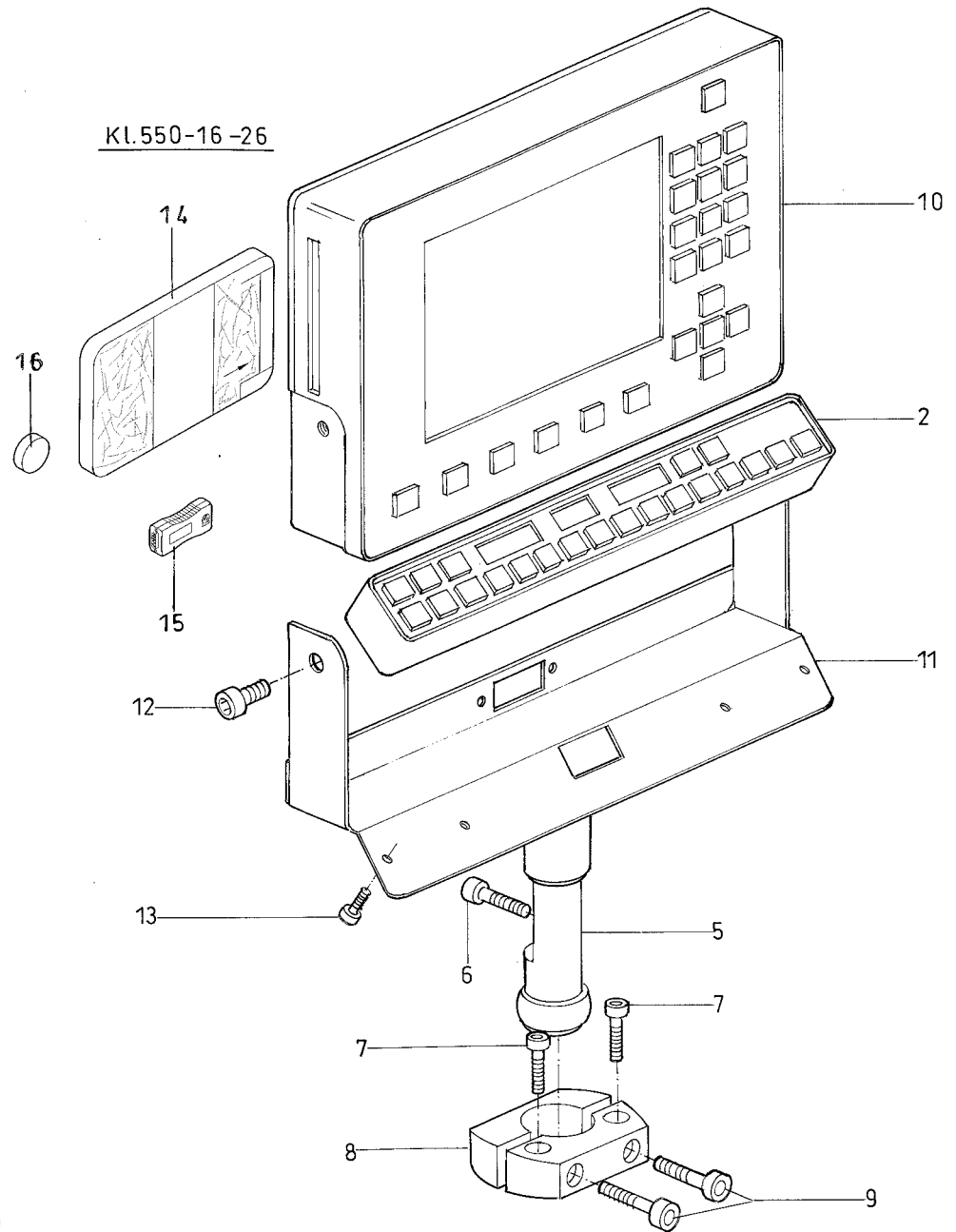

Pos.	Teile-Nr. / Part no.	Benennung	Denomination
		BEDIENFELD	CONTROL PANEL
2	9850 550054	Tastenleiste K.	key reglet cpl.
3	9202 001718	Zyl. Schraube	cyl. screw
4	6279 490063	Halterung V	holding device cpl.
5	6279 490030	Kalotte	part
6	9202 002473	Zyl. Schraube	cyl. screw
7	9202 002093	Zyl. Schraube	cyl. screw
8	6279 490020	Aufnahme	acceptance
9	9202 002938	Zyl. Schraube	cyl. Screw
10	9850 001030	Bedienfeld K. (bis 31.12.08)	control panel cpl. (up to 31.12.08)
10	9850 001080	Bedienfeld K (ab 01.01.09)	control panel cpl. (from 01.01.09)
11	6279 490013	Halterung V	holding device
12	9202 023288	Zyl. Schraube	cyl. screw
13	9202 001658	Zyl. Schraube	cyl. screw
14	9805 791114	RAM-Card (bis 31.12.08)	RAM-CARD (up to 31.12.08)
15	9805 791113	USB-Stick (ab 01.01.09)	USB-STICK (from 01.01.09)
16	9810 920003	Batterie f. RAM-Card (bis 11.2000)	Batterie f. RAM-card (up to 11.2000)
16	9810 920004	Batterie f. RAM-Card (ab 12.2000)	Batterie f. RAM-card (from 12.2000)

Pos.	Teile-Nr. / Part no.	Benennung	Denomination
------	----------------------	-----------	--------------

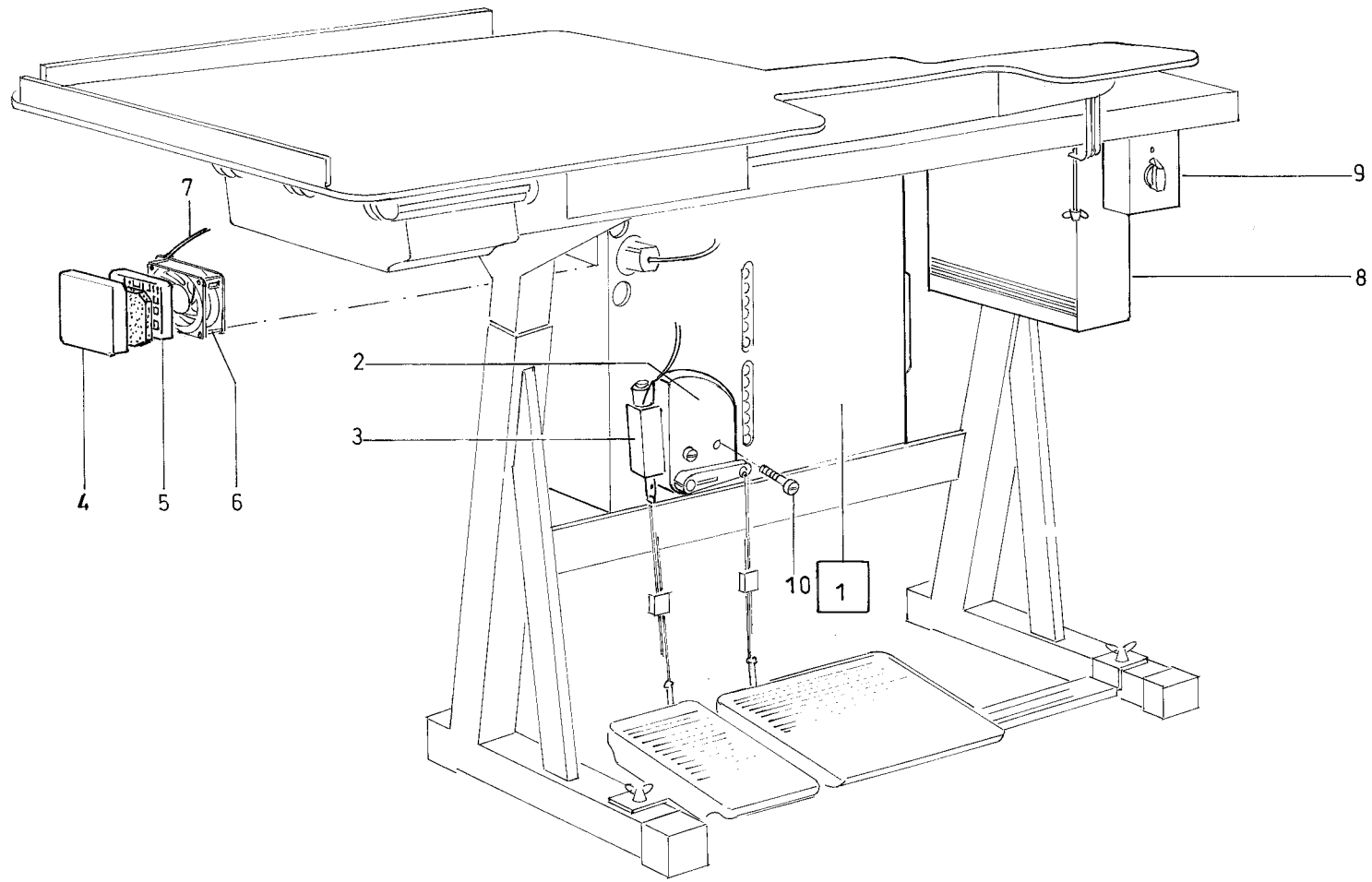

Pos.	Teile-Nr. / Part no.	Benennung	Denomination
		ELEKTRO	ELECTRIC
1	9870 550034	Schaltschrank K	switch cabinet cpl.
1		(Mit Pos. 2 - 7, 10)	(with pos. 2 - 7, 10)
2	9800 330012	Ext. Betaetigung	setpoint generator
3	9800 350002	Sollwertgeber	set value initiator
4	9800 551001	Austrittsfilter	filter
5	9800 551004	Schutzgitter	protection grid
6	9800 551000	Luefter, axial	ventilator
7	9840 502007	Leitung , Netz	cord
8	9800 331102	Steuerkasten	control box
9	9815 580008	Hauptschalter	main switch
10	9202 002957	Zyl. Schr.	cyl. Screw

Pos.	Teile-Nr. / Part no.	Benennung	Denomination
------	----------------------	-----------	--------------

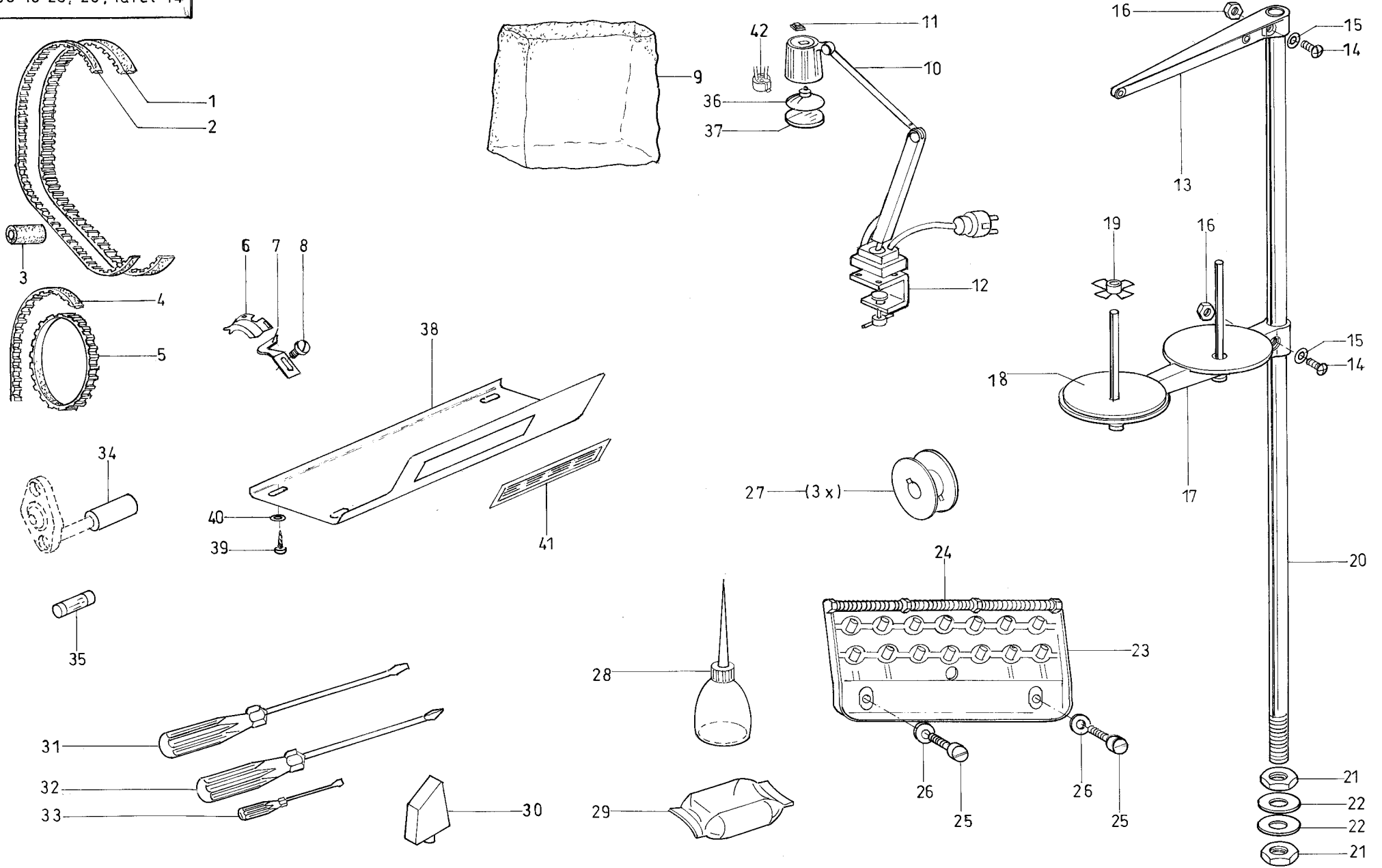

Pos.	Teile-Nr. / Part no.	Benennung	Denomination
		BEIPACK	ACCESSOIRES
1	9130 240010	Zahnriemen (bis 05.2009)	toothed belt (up to 05.2009)
1	9130 240050	Zahnriemen (ab 06.2009)	toothed belt (from 06.2009)
2	0396 342880	Zahnriemenrad (bis 05.2009)	belt pulley (up to 05.2009)
2	9130 240060	Zahnriemenrad (ab 06.2009)	belt pulley (from 06.2009)
3	0568 340320	Rolle	roller
4	0568 340570	Zahnriemen (bis 05.2009)	toothed belt (up to 05.2009)
4	9130 240070	Zahnriemen (ab 06.2009)	toothed belt (from 06.2009)
5	0568 341130	Zahnkranz	tooth pointing
6	0568 350360	Fadenz. Messer	knife
7	0568 350370	Gegenmesser	counter knife
8	0992 024358	Zyl. Schr.	cyl. screw
9	0104 250010	Haube	cap
10	9822 510000	Naehleuchte (bis 05.2007)	lamp (up to 05.2007)
10	9822 510002	Naehleuchte (ab 06.2007)	lamp (from 06.2007)
11	0002 007504 9500	Wippschalter	switch
12	9822 510011	Tischklemme	table clamp
13	0791 001200	Fadenfuehrung	thread guide
14	9204 202038	Linsenschr.	screw
15	0791 001093 A	Scheibe	washer
16	0791 001095	Mutter	nut
17	0791 001091	Garnhaltearm K.	thread reel holder cpl.
18	0077 110022 0	Auflage	rest
19	0077 110230	Zentrierstueck	centering piece
20	0791 001081	Garnst. Rohr	thread unwinder tube
21	0995 340617	6Kt. Mutter	hexagonal nut
22	9330 000177	Scheibe	washer
23	0381 170070	Spulenmagazin	bobbin hopper
24	0381 170080	Klemmfeder	lock spring
25	MG41 004073	Spanpl. Schr.	screw
26	9330 900097	Scheibe	washer
27	0204 000230 A	Spule	bobbin
28	0052 000369	Oelkanne	oil can
29	0211 000699	Oelkissen	oil pillow
30	6279 400020	Oberteilstuetze	machine head support

Pos.	Teile-Nr. / Part no.	Benennung	Denomination
31	9081 500051	Schraubendreher	cscrew driver
32	0791 000007	Schraubendreher	screw driver
33	9081 500010	Schraubendreher	screw driver
34	0568 340930	Gleitstueck	sliding block
35	9825 810410	Sicherung T0,8/250G	safety T0,8/250G
36	9822 642024	Halogenlampe (bis 05.2007)	halogen lamp (up to 05.2007)
36	9822 642027	Halogenlampe (ab 06.2007)	halogen lamp (from 06.2007)
37	9822 510012	Glasscheibe (bis 05.2007)	pane (up to 05.2007)
37	9822 510013	Glasscheibe (ab 06.2007)	pane (from 06.2007)
38	6279 340380	Oelwanne	oil wanne
39	9204 201668	Linsenschraube	screw
40	9330 000177	Scheibe	washer
41	9401 000017	Lueftungsgitter	grid
42	0002 007504 8580	Fassung, Halogen (bis 05.2007)	socket, Halogen (from 06.2007)

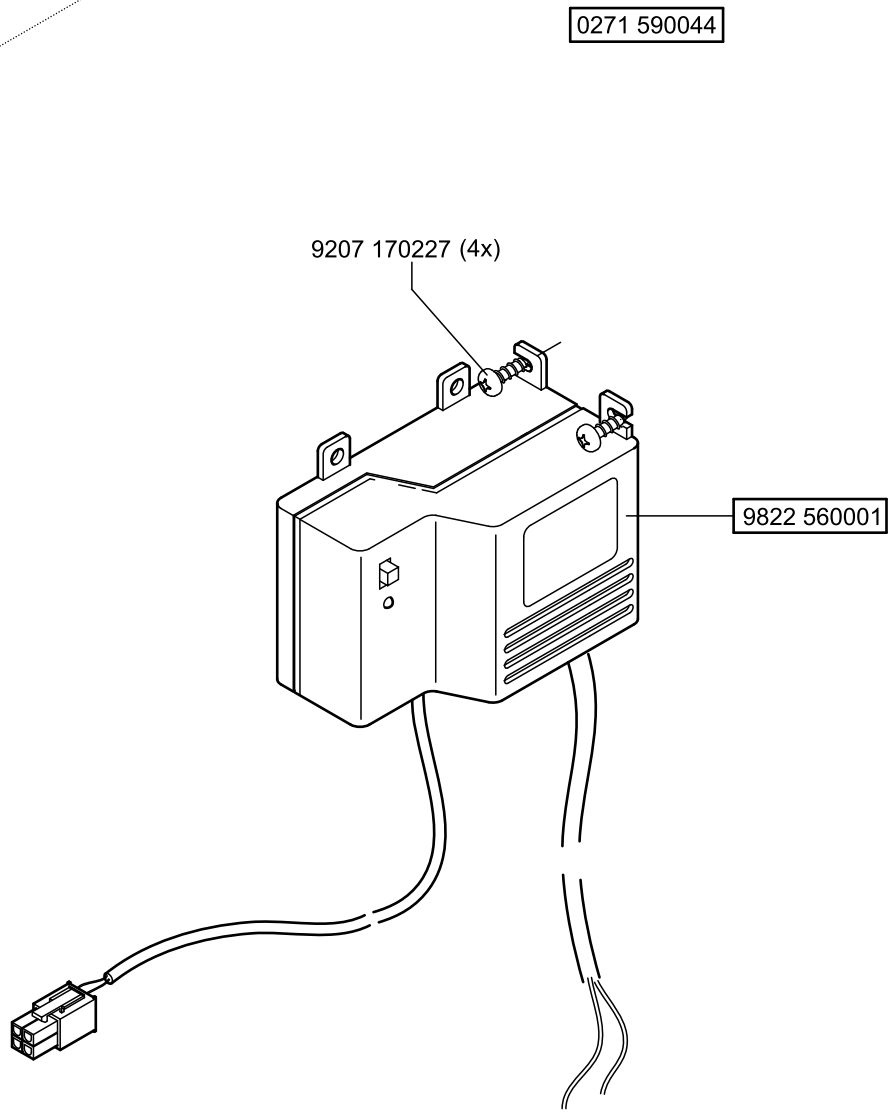
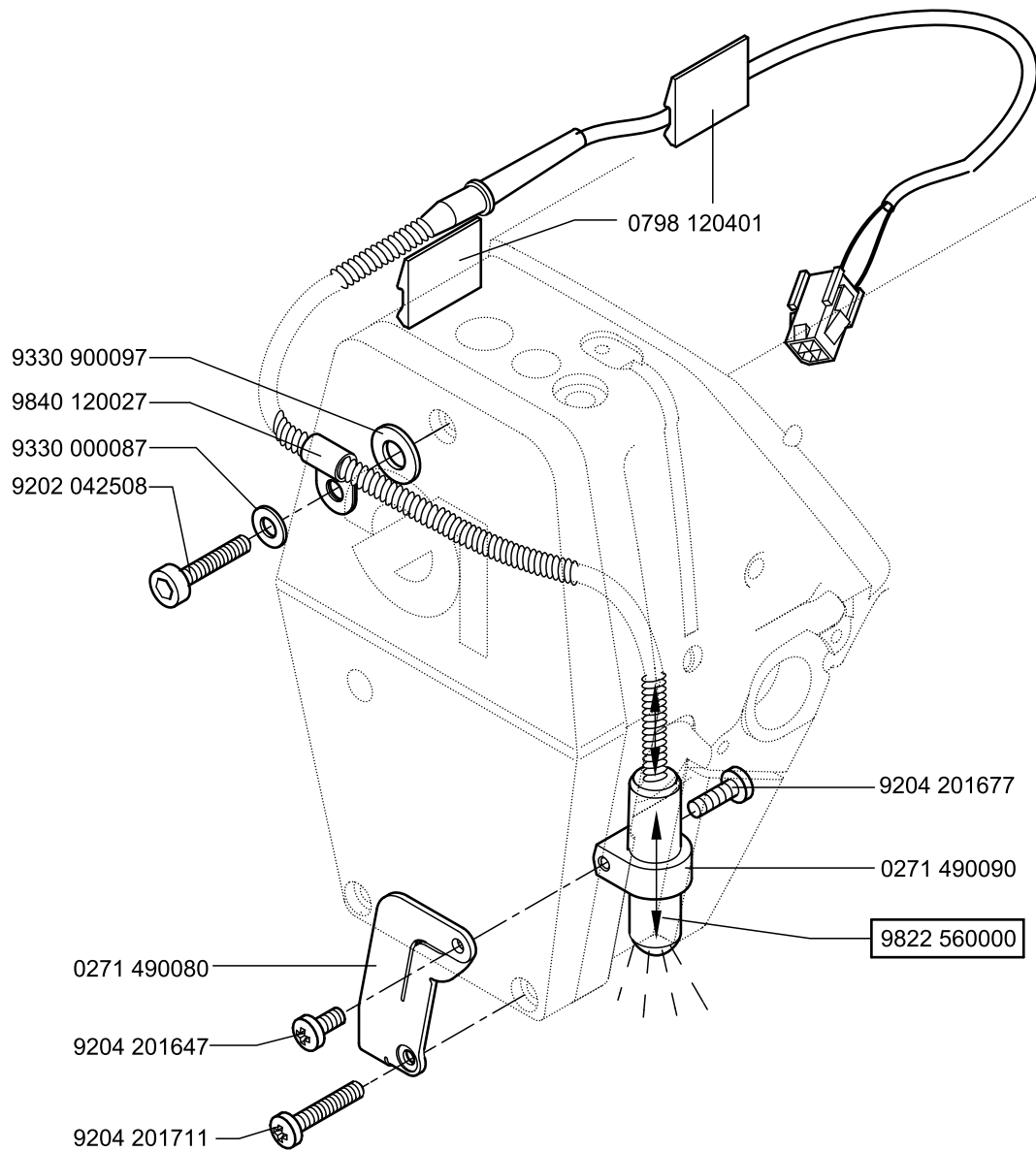

Teile-Nr. / Part no.	Tafel / Table	Teile-Nr. / Part no.	Tafel / Table	Teile-Nr. / Part no.	Tafel / Table	Teile-Nr. / Part no.	Tafel / Table
0002 005889 0700	003	0211 000390 A	003	0244 000398	002	0271 000274	002
0002 007504 8580	014	0211 000390 K	003	0244 000399	002	0271 000275	002
0002 007504 9500	014	0211 000391 A	003	0244 000400	002	0271 000276	002
0002 008308 3325	003	0211 000394	003	0244 000401	002	0271 000298	002
0002 008930 0070	003	0211 000395	003	0244 000403	002	0271 000300	002
0002 008930 0100	002	0211 000397	003	0244 000404	002	0271 000301	002
0004 000079	001, 002	0211 000398	003	0244 000414	001, 002	0271 000316	003
0030 001340	001	0211 000405	003	0244 000415	001, 002	0271 000318	003
0052 000369	014	0211 000406	003	0244 000700	009	0271 000756	001, 005, 007, 008
0053 000350	001	0211 000407	003	0246 000466	002	0271 000759	007
0069 250060	011	0211 000408	003	0271 000009	001	0271 001064	003
0077 110022 0	014	0211 000412 A	003	0271 000014	003	0271 001069	003
0077 110230	014	0211 000438	004	0271 000026	003	0271 001385	001
0098 002990	001	0211 000439	004	0271 000029	001, 003	0271 001391	001
0104 250010	014	0211 000440	004	0271 000054	003	0271 001392	001
0114 000202	002	0211 000459	001	0271 000072	003	0271 001397	001, 002
0170 150610	005	0211 000699	014	0271 000095	003	0271 120133	003
0171 003043	002	0211 001127	007	0271 000096	003	0271 130030	004
0171 100103	001	0211 001129	007	0271 000100	003	0271 130130	004
0171 130010	001	0211 050214	001, 002	0271 000119	003	0271 130140	003
0195 350014	002	0211 050215	001	0271 000124	001	0271 130160	001
0204 000230 A	007	0212 000016 B	003	0271 000165	004	0271 130170	001
0204 000230 A	014	0212 000151	003	0271 000187	001	0271 130190	001
0211 000013	002	0212 004786	006	0271 000197	001	0271 140070	009
0211 000018	009	0216 000070	009	0271 000199	001	0271 150034	007
0211 000025	009	0216 000224	001	0271 000200	001	0271 150040	007
0211 000152	003	0216 000288	001	0271 000201	001	0271 150054	007
0211 000208	003	0216 000591	002	0271 000212	001	0271 150060	007
0211 000299	003	0216 000603	002	0271 000215	001	0271 150070	007
0211 000302 B	003	0216 001146	001	0271 000217	001	0271 150080	007
0211 000305 A	003	0219 000353	002, 005	0271 000222	001	0271 150090	007
0211 000316	003	0223 000237	009	0271 000227	001	0271 380034	003
0211 000317	003	0223 000238	009	0271 000236	001	0291 000159	003
0211 000331	003	0223 000646	003	0271 000237	001	0296 150013	001
0211 000332	003	0223 000648	002	0271 000260	002	0367 115250	001
0211 000339	003	0239 000509	011	0271 000262	002	0381 170070	014
0211 000376	003	0244 000396	002	0271 000273	002	0381 170080	014

Teile-Nr. / Part no.	Tafel / Table	Teile-Nr. / Part no.	Tafel / Table	Teile-Nr. / Part no.	Tafel / Table	Teile-Nr. / Part no.	Tafel / Table
0396 222530	005	0568 350280	006	0797 002205	002	6279 130093	004
0396 342580	001	0568 350310	006	0797 003031	011	6279 130123	004
0396 342880	005, 014	0568 350340	006	0933 000075	003	6279 130144	004
0396 343073	001	0568 350360	006, 014	0933 001533	002	6279 130150	003
0396 343150	001	0568 350370	006, 014	0933 001544	004	6279 130183	001
0396 350400	006	0568 350383	006	0933 002284	002	6279 130200	004
0396 350660	009	0568 350394	006	0935 103438	001	6279 130210	004
0396 351680	009	0570 000055	003	0935 150010	010	6279 130253	004
0396 351713	009	0570 001847	010	0971 411950	006	6279 140030	006
0396 351720	009	0570 010007	003	0992 023677	005	6279 140050	006
0396 351730	009	0620 760092	002	0992 024358	006, 014	6279 140060	006
0504 330920	009	0700 000043	011	0993 991910	001	6279 140093	006
0540 100830	001	0700 000044	011	0995 340617	014	6279 140164	009
0540 110080	001, 002	0700 000045	011	0996 060250	001	6279 150010	006
0556 000148	003	0700 000050	011	0998 860280	005	6279 150014	006
0556 005040	009	0700 000056	011	0998 880580	006	6279 150023	006
0558 010052	004	0700 000092	011	0998 881020	002	6279 150040	009
0568 140600	006	0700 000441	011	0998 881080	004, 005	6279 150053	009
0568 140642	006	0700 627901	011	0998 881520	001	6279 220013	005
0568 140690	006	0700 627902	011	0998 881610	008	6279 220014	005
0568 140710	006	0718 000254	011	0998 882080	005	6279 220020	005
0568 140713	006	0742 002096	011	0998 885050	001	6279 220030	005
0568 150150	006, 009	0742 055716	006	0999 210569	005	6279 220040	005
0568 150660	006	0744 001369	005	0999 220752	003	6279 220050	005
0568 150700	006	0744 001793 A	011	0999 220756	009	6279 220070	005
0568 150710	006	0744 001793 B	011	0999 240303	011	6279 220073	005
0568 200320	006	0744 020505	009	0999 240341	011	6279 220080	005
0568 220140	005	0767 150140	001	1001 001162	003	6279 220090	005
0568 220440	005	0767 150143	001	1001 003102	002	6279 290010	003
0568 250100	011	0767 150144	001	6279 100020	003	6279 290020	007
0568 340090	001	0767 150150	001	6279 100040	002	6279 340010	008
0568 340320	014	0791 000007	014	6279 100050	003	6279 340023	008
0568 340530	001	0791 001081	014	6279 100054	003	6279 340024	008
0568 340570	006, 014	0791 001091	014	6279 110010	002	6279 340030	008
0568 340930	014	0791 001093 A	003, 014	6279 130040	004	6279 340070	008
0568 340940	006	0791 001095	014	6279 130070	004	6279 340083	008
0568 341130	006, 014	0791 001200	014	6279 130080	004	6279 340100	010

Teile-Nr. / Part no.	Tafel / Table	Teile-Nr. / Part no.	Tafel / Table	Teile-Nr. / Part no.	Tafel / Table	Teile-Nr. / Part no.	Tafel / Table
6279 340134	005	6279 350030	003, 010	9130 240070	005, 014	9203 312411	003
6279 340140	005	6279 350050	009	9130 240400	005	9203 312451	005
6279 340153	005	6279 350060	009	9130 244200	005	9203 313047	001
6279 340183	005	6279 350070	009	9130 244201	008	9203 314257	011
6279 340190	005	6279 350083	009	9201 250027	011	9203 314637	011
6279 340200	005	6279 350090	006	9202 001658	005, 006, 012	9203 401870	006
6279 340210	005	6279 350100	006	9202 001698	005	9204 101658	005
6279 340220	005	6279 350140	006	9202 001718	012	9204 201648	001, 003
6279 340240	006	6279 400020	014	9202 002063	009, 010	9204 201668	001, 003, 014
6279 340244	006	6279 400030	011	9202 002068	005	9204 201677	001
6279 340260	006	6279 400070	011	9202 002073	001, 004, 005, 009	9204 201723	002
6279 340283	005	6279 490013	012	9202 002093	001, 005, 006, 010, 012	9204 201977	003
6279 340320	005	6279 490020	012	9202 002097	008, 009	9204 202038	014
6279 340333	005	6279 490030	012	9202 002388	010	9205 023658	002
6279 340340	005	6279 490063	012	9202 002473	012	9205 101848	006
6279 340350	005	9041 100025	004	9202 002488	003, 005	9205 102143	005, 008
6279 340360	005	9041 100030	002, 003	9202 002493	010	9205 102168	001
6279 340380	014	9041 100035	001	9202 002497	004	9205 102178	001
6279 340390	009	9041 100050	003	9202 002498	010	9205 102188	008
6279 340400	010	9041 100203	003	9202 002507	001	9205 102473	003, 009, 010
6279 340410	010	9041 102025	003	9202 002508	005, 010	9205 102478	003
6279 340420	010	9081 500010	014	9202 002527	006	9205 102788	001
6279 340430	010	9081 500051	014	9202 002888	008	9206 200097	011
6279 340440	005	9099 888255 0	006	9202 002937	009	9207 170227	011
6279 340460	001	9110 000010	008	9202 002938	012	9207 170457	011
6279 340500	001	9120 030081	009	9202 002957	013	9207 170847	011
6279 340510	005	9120 030084	006	9202 023288	012	9217 300518	001
6279 340520	005	9120 030121	008, 009	9202 042477	006	9217 300528	002
6279 340530	005	9120 030151	009	9203 001808	005	9225 201750	006
6279 340543	005	9120 080250	003	9203 001917	010	9231 000368	004
6279 340553	005	9122 200150	003	9203 003042	006, 010	9231 000377	005
6279 340603	008	9129 016060	003	9203 003653	003	9231 000378	002, 009
6279 340613	008	9130 221051	009, 010	9203 100001	002	9231 110038	005
6279 340623	005	9130 221052	003, 009	9203 100631	004	9231 110053	005
6279 340633	005	9130 240010	005, 014	9203 113671	001	9231 110058	002, 005
6279 350010	009	9130 240050	006, 014	9203 113983	001	9231 110107	004
6279 350023	009	9130 240060	005, 014	9203 123682	006	9231 110108	005, 010

Teile-Nr. / Part no.	Tafel / Table	Teile-Nr. / Part no.	Tafel / Table	Teile-Nr. / Part no.	Tafel / Table	Teile-Nr. / Part no.	Tafel / Table
9231 110127	011	9731 001035	002	MG41 004073	014		
9231 110137	006	9731 002001	011	MG43 000062	011		
9301 100981	006	9780 000108	011	MG43 000403	011		
9301 101611	009	9790 111001	011	MG43 000451	011		
9301 102211	006	9790 130010	011	MG43 002150	011		
9303 700607	005	9790 200000	004, 010	MG53 002501	011		
9330 000068	010	9790 201000	009, 010	MG53 002521	011		
9330 000088	001, 004, 005, 010	9800 130103	010	MG53 007921	011		
9330 000097	010	9800 330012	013	MG53 007922	011		
9330 000098	005, 010	9800 331102	013	MG55 000501	011		
9330 000127	006	9800 350002	013	N800 045144	007		
9330 000167	011	9800 551000	013				
9330 000177	014	9800 551001	013				
9330 900097	014	9800 551004	013				
9334 102110	004	9800 580011	005, 008				
9352 000060	002	9805 791113	012				
9352 000080	004, 006, 009	9805 791114	012				
9352 000120	008	9810 920003	012				
9352 000150	009	9810 920004	012				
9352 000180	005	9815 580008	013				
9352 500070	003	9815 710203	010				
9357 000050	009	9822 510000	014				
9357 000060	001, 004	9822 510002	014				
9357 000070	002	9822 510011	014				
9357 000090	001	9822 510012	014				
9357 200056	011	9822 510013	014				
9357 200106	011	9822 642024	014				
9390 000010	001	9822 642027	014				
9400 000138	010	9825 810410	014				
9400 100009	004	9840 120026	003				
9401 000017	014	9840 120027	010				
9401 000021	011	9840 502007	013				
9700 100033	004	9850 001030	012				
9700 100059	001	9850 001080	012				
9710 061200	010	9850 550054	012				
9710 900035	010	9870 550034	013				
9710 982003	010	9880 002002	011				

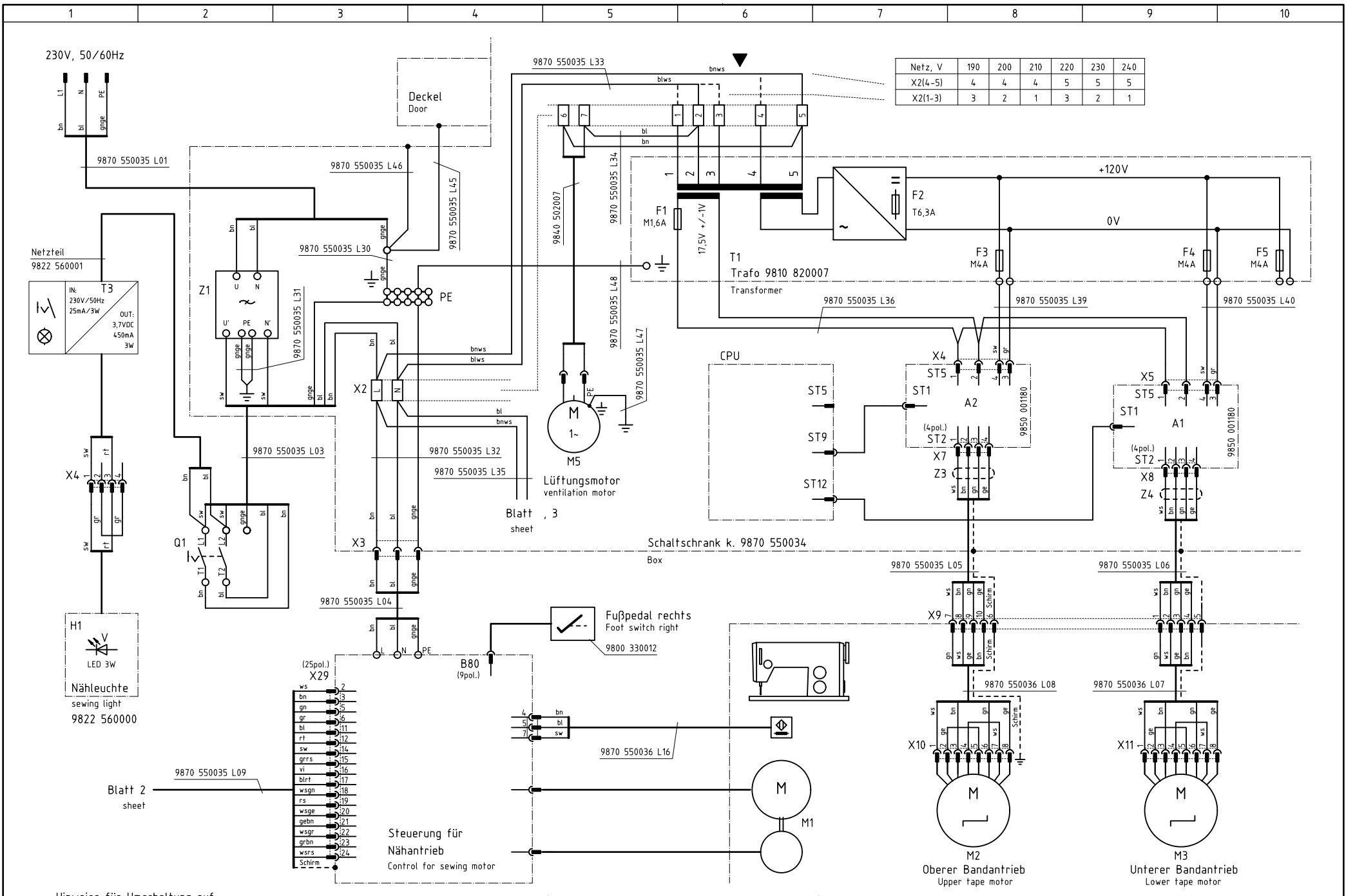

Netz, V	190	200	210	220	230	240
X2(4-5)	4	4	4	5	5	5
X2(1-3)	3	2	1	3	2	1

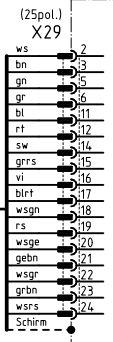
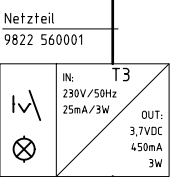

Hinweise für Umschaltung auf andere Netzspannung beachten!
 Observe the notes for changsover to other main voltages!

Zusatzausstattung
 Optional equipment

c			Datum	07.09.98
b			Bearb.	Hd
a	07.0	28.02.07	Cz	Gepr.
	Änderung	Datum	Name	Norm



DÜRKOPP
 ADLER AG
 Bielefeld

Teilfamilie	550-16-23, -26
Freigabe	0005 / 07

Bauschaltplan
 9870 550033 B

Blatt
 1/4

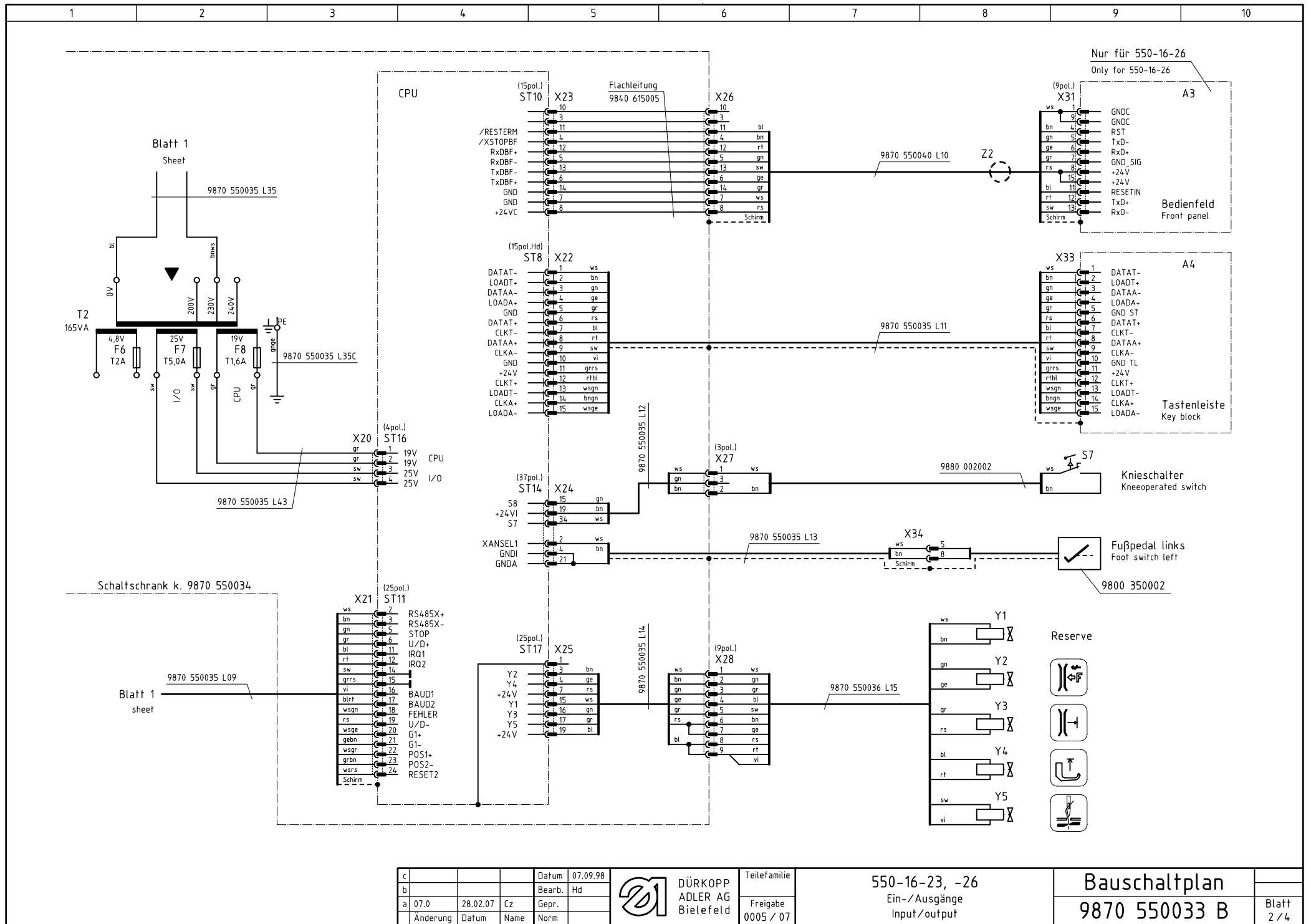

c			Datum	07.09.98
b			Bearb.	Hd
a	07.0	28.02.07	Cz	Gepr.
	Anderung	Datum	Name	Norm



DÜRKOPP
ADLER AG
Bielefeld

Teilfamilie	550-16-23, -26
Freigabe	0005 / 07

550-16-23, -26
Ein-/Ausgänge
Input/output

Bauschaltplan
9870 550033 B

Blatt
2 / 4

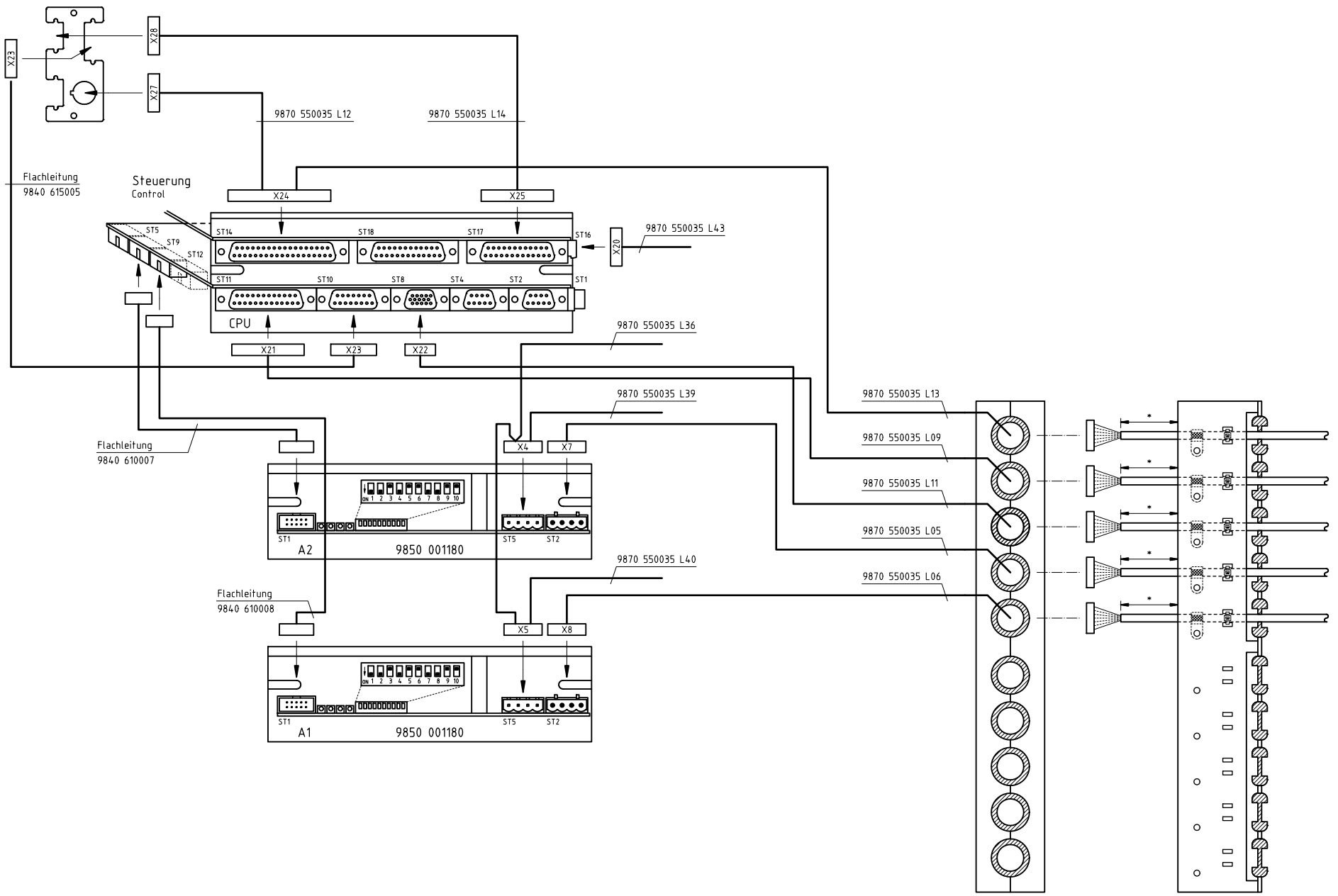

* : Maß durch Schirmbefestigung vorgegeben
Size depends on the shield attachment

c				Datum	07.09.98
b				Bearb.	Hd
a	07.0	28.02.07	Cz	Gepr.	
	Änderung	Datum	Name	Norm	



**DÜRKOPP
ADLER AG**
Bielefeld

Teilefamilie	
Freigabe	0005 / 07

550-16-23, -26
Steuerung DAC-2B, Anschlussplan
Control DAC-2B, connecting diagram

Bauschaltplan	
9870 550033 B	

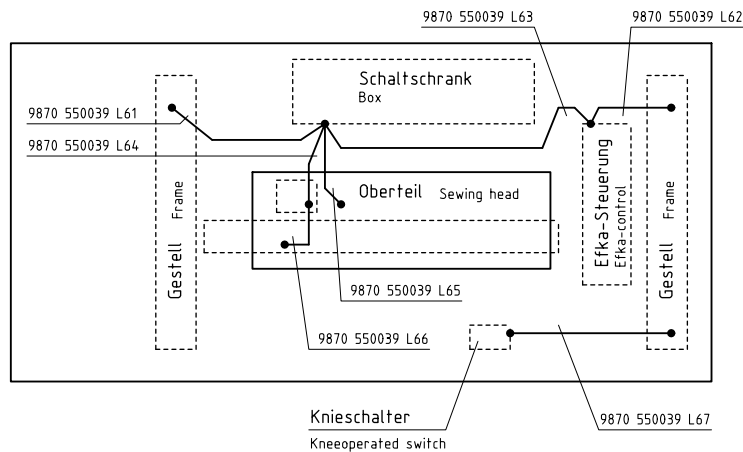
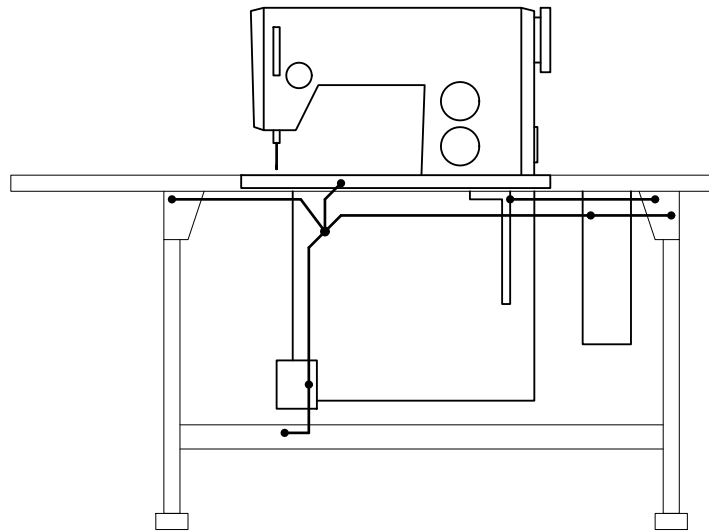

Potentialausgleich
Potential compensation

Kurzz.	Teilenummer	Benennung	denomination	Typ	Bemerkung
A1, A2	9850 001180	Verstärker, -SM	amplifier	DAC-2B	
A3	9850 001030	Bedienfeld	front panel	BF1C	
A4	9850 550054	Tastenleiste	key block		
CPU	9850 550052	CPU	cpu	DAC-2C	550-16-23
CPU	9850 550053	CPU	cpu	DAC-2C	550-16-26
F1	9825 810312	Sicherung	fuse	M1,6A	5x20mm
F2	9825 810417	Sicherung	fuse	T6,3A	5x20mm
	9825 830222	Sicherung	fuse	F12,5A	6,35x32mm
F3-F5	9825 810316	Sicherung	fuse	M4,0A	5x20mm
F7	9825 810423	Sicherung	fuse	T5,0A	5x20mm
F8	9825 810413	Sicherung	fuse	T1,6A	5x20mm
H1	9822 560000	Nähleuchte	sewing light	LED 3W	
M1	9800 130102 R	Nähantrieb	sewing motor	DC1500/AB285A	1x190-240V 50/60Hz
M1.1	9800 130103	Nähmotor	sewing motor	DC1500	
M1.2	9800 331102	Steuerkasten	control box		
M2, M3	9800 580011	Schrittmotor	step motor	MT23PM22033M8	
M5	9800 551000	Filterlüfter	ventilation motor		230VAC
M5.1	9800 551001	Austrittfilter	filter		
Q1	9815 580008	Hauptschalter	main switch		
T1	9810 820007	Transformator	transformer	120VDC 6,3A	750VA
T2	9810 820003	Transformator	transformer	19V, 25V, 4,8V	162VA
T3	9822 560001	Netzteil	power supply	3,7VDC / 3W	LED Nähleuchte
Z1	9810 711006	Netzfilter	filter	F-250V-B90, 6A	
Z2	9810 719003	Ferrit-Joch	ferrite clamp	MSFC-8	
Z3, Z4	9810 719035	Ferrit-Ringkern	ferrite		

9870 550033 B/4

c			Datum	07.09.98
b			Bearb.	Hd
a	07.0	28.02.07	Cz	Gepr.
	Anderung	Datum	Name	Norm



DÜRKOPP
ADLER AG
Bielefeld

Teilenummer	550-16-23, -26
Freigabe	0005 / 07

Potentialausgleich, Teiliste
Potential compensation, part list

Bauschaltplan
9870 550033 B