

FINEST QUALITY

Union Special[®]

LEWIS · COLUMBIA

**INDUSTRIAL
SEWING
MACHINES**

**STYLES
33700 A
33700 C**

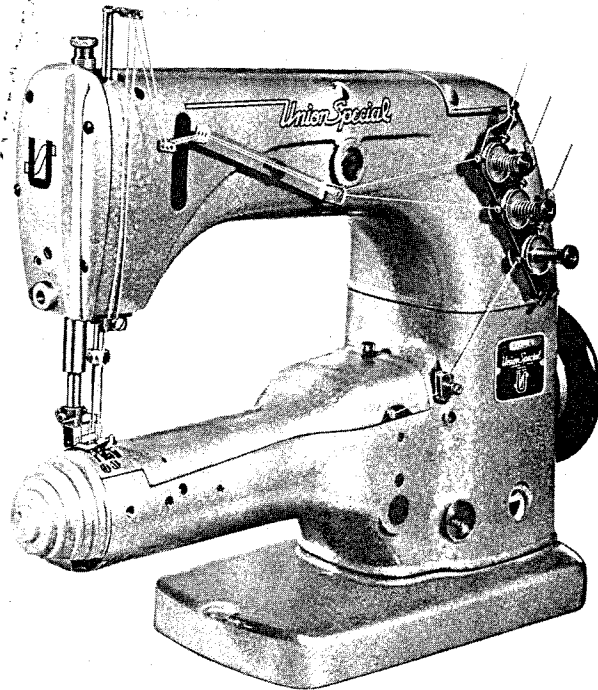

CLASS 33700

**HIGH SPEED RIGHT HAND CYLINDER BED
HEMMING MACHINES**

**CATALOG
No. 253**

Union Special **MASCHINENFABRIK** G.M.
B. H. **STUTT GART W SCHWABSTRASSE 33**

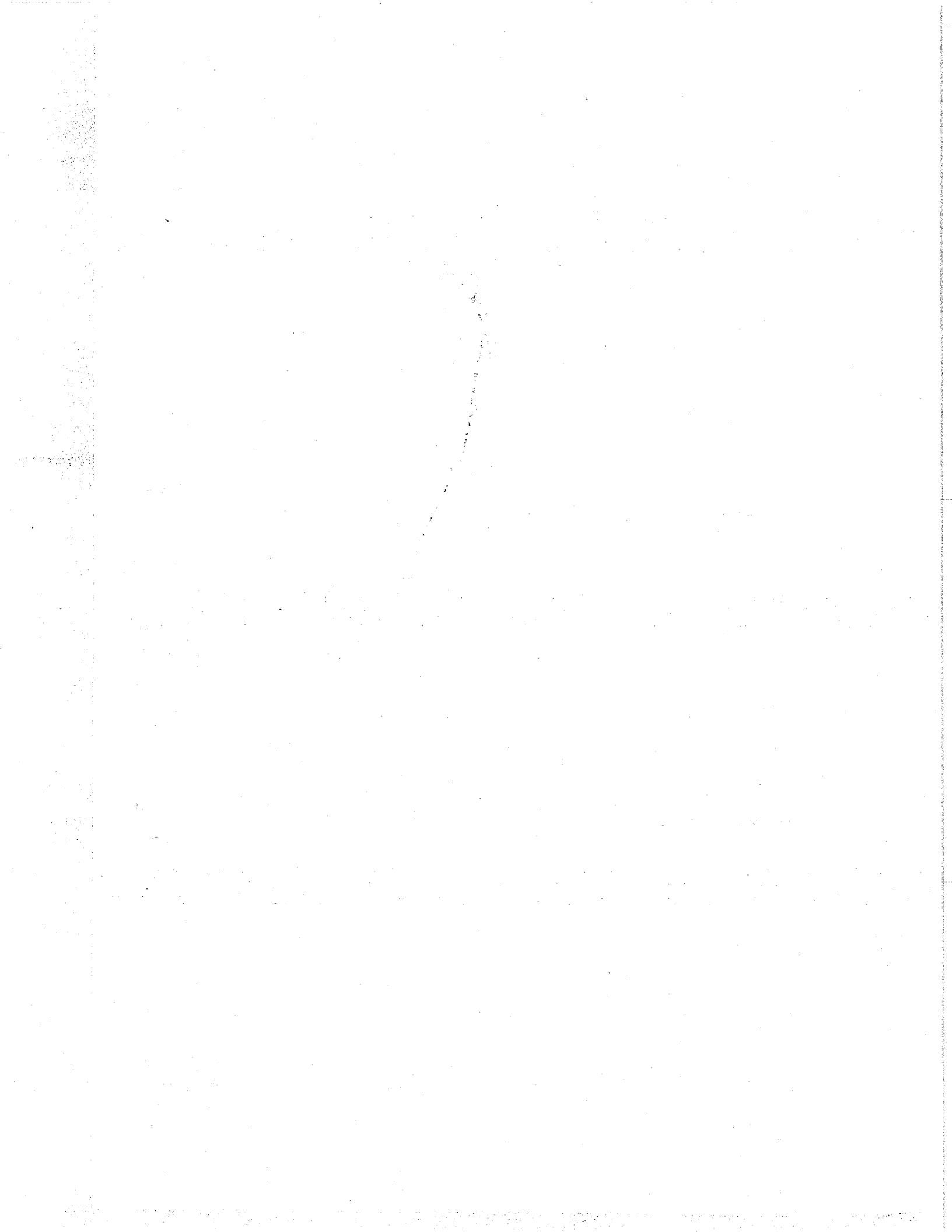

CATALOG

No. 253

INSTRUCTIONS FOR ADJUSTING AND OPERATING

LIST OF PARTS

CLASS 33700

STYLES
33700 A
33700 C

The parts listed in this catalog are furnished at list prices for repairs only.

First Edition

Printed by

Union Special **MASCHINENFABRIK** G.M. S.H. **STUTT GART-W SCHWABSTRASSE 33**

October, 1965

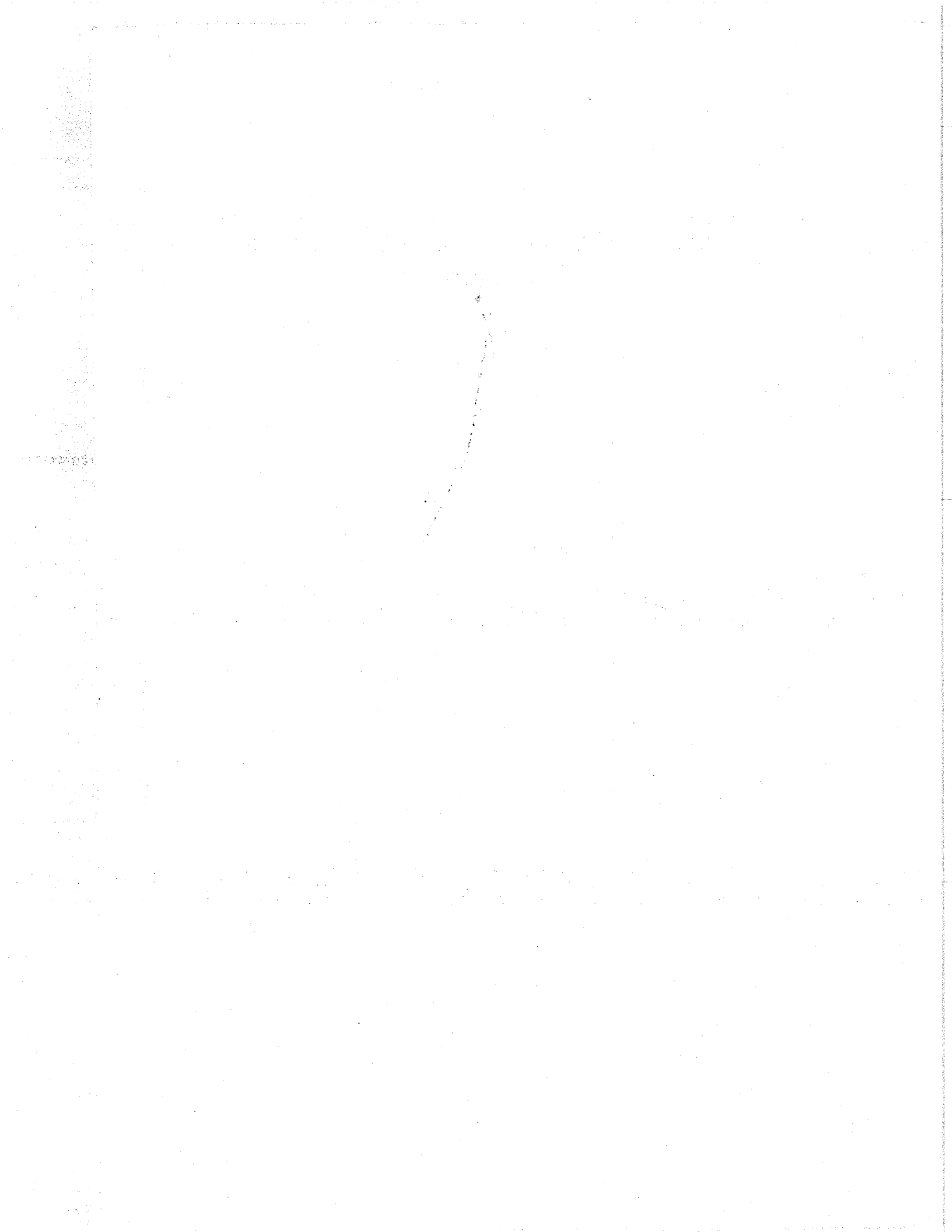

ADJUSTING INSTRUCTIONS

DESCRIPTION OF MACHINES

33700 A-16 1/2 Streamlined, plain feed, right hand cylinder machine with needle bearing crankshaft and feed drive mechanism. Two needle, one looper machine for hemming necks and armholes of bathing suits, with fabric folded next to feed dog. Split folding attachment that can be adjusted from 3/8 to 3/4 inch fold and knee press for opening same. Seam specification 406-EFa-1 (inverted). Standard gauge No. 16. Needle Type 124 B. Stitch range 8 to 14, set at 12 S.P.I.

33700 A-16-1 Same as 33700 A-16 1/2 except attachment can be adjusted from 3/4 to 1 1/2 inches of fold.

33700 C Streamlined, plain feed, right hand cylinder machine with needle bearing crankshaft and feed drive mechanism. Two needle, one looper machine for the second part of the two operation covered seam on knitted outerwear and similar garment. Seam specification 406-SSh-2. Standard gauge No. 16. Needle Type 121 GS. Stitch range 8 to 14, set at 10 S.P.I.

Speed of these machines is 4200 R.P.M.

CAUTION: Operating direction of machines is clockwise.

Needle Lever Stud

Check the location of the needle lever stud in relation to its oil grooves. The stud is set correctly when the arrow stamped on the head points vertically upward. On machines with Serial No. D 85891 to D 85910 the arrow must point upward to the left with an angle of 45°.

Lubrication

As the oil has been drained from the machine before shipment the reservoir must be filled before starting to operate. Use Gargoyle Arctic Oil C Heavy or a straight mineral oil with a Saybolt viscosity of 200 to 250 seconds at 100° Fahrenheit (Spec 83), which can be obtained from any UNION SPECIAL representation. Be sure that the oil level is always between the two red lines of the oil gauge on the right front side of the lower bed. If the level is below the lower red line, oil must be added. The oil should be renewed once a year. The reservoir is filled with oil on the right side at the top. The drain plug screw is located in the base plate on machines with serial numbers below 95731; beginning with this number the drain plug screw is located on the side of the machine, below the pulley.

Please note that only the six oil holes marked with red colour need oiling by hand twice a week. The remaining mechanism is automatically lubricated.

Cleaning of Machine

The machine must be cleaned thoroughly before oiling the six oil holes. Important: remove throat plate and clean feed dog slots. Before starting to operate remove the cover on the top of the cylinder and oil all bearings. Run machine slowly for several minutes to allow the oil wicks to carry oil to the bearings. Then repeat oiling and run the machine at the recommended speed for five minutes. Close the cover and begin to operate the machine.

Setting of Needles

Put in one pair of needles Type 124 B for Style 33700 A and Type 121 GS, for Style 33700 C size as specified and turn the needle bar so that the needles center in the front ends of the needle slots of the throat plate. The long groove of the needles must be directed towards the operator.

Looper Gauge

Adjust the looper so that the distance from the center of the right hand needle to the looper point is $3/16$ inch when the looper is in its extreme right position. Looper gauge No. 21225 $3/16$ can be used advantageously for making this adjustment.

When adjusting the looper, hexagonal screw 74 and set screw 96 B on the looper driving lever must be loosened. Then the looper drive lever can be turned until the looper has the correct distance to the needle. After again tightening the two screws the looper thread take-up must move freely in its complementary parts.

Height of Needle Bar

Set the needle bar so that the top of the left needle's eye is $3/64$ inch below the looper when the looper is moving to the left and its point is even with the left side of the left needle. Please note that no lateral motion of the looper drive lever occurs when it is turned as this would impair the clearance between take-up plate and take-up disc.

Looper Avoid Motion

When the Looper moves to the left the looper point should pass the rear of the right needle as close as possible without contacting. This adjustment of the looper avoid motion can be changed by turning the looper shaft after loosening the clamp screws in the looper avoid driving lever. These clamp screws are accessible after removing screws 3 and 4 on the rear side of the cylinder. (See oiling and threading diagram 17998 M). When inserting screws 3 and 4 use a cement material.

Looper Needle Guard

The looper needle guard is set correctly when it moves to the left and barely touches the front of the right needle and a space of .002 to .005 inch remains between the looper point and the rear side of the left needle.

Rear Needle Guard

Set the rear needle guard so that it barely contacts the needles at its most forward point of travel. Readjustment of the needle guard is necessary after every change of stitch length. For uniform feeding make sure that the entire bottom of the presser foot contacts the throat plate. Make sure that the needles do not contact when entering the needle hole in the presser foot.

Stitch Range

Regulating the desired number of stitches per inch is accomplished at the left end of the main shaft. The number of stitches can be altered after loosening the nut and turning the stitch regulating screw.

Turning it to the right lengthens the stitch, and turning to the left shortens it. To loosen the lock nut use wrench No. 21388 and turn it in operating direction.

Stitch Range (Continued)

Apply the wrench with the left hand and hold the machine pulley with the right hand. Always tighten the lock nut carefully after a change has been made.

The rear needle guard must be readjusted each time the stitch length has been altered.

Height Adjustment of Feed Dog

The feed dog is set correctly when the tips of its teeth project $\frac{3}{64}$ inch above the throat plate when the feed dog is in its highest position. When setting the height of the feed dog it is extremely important to observe the following instructions:

All the differential parts of the feed mechanism are factory set to perfect parallelism. This parallelism is essential for trouble free performance of the machine and must be maintained under all circumstances.

The proper height of the feed dog is to be adjusted only on the feed lift driving lever 33735 B.

Do not try to use the left feed rocker (11742) or right feed rocker (11743) for adjusting the height of the feed dog.

To secure the required parallelism when setting the height of the feed dog remove the two plug screws 1 and 2 on the rear side of the cylinder and loosen the two clamp screws 22569 B on the feed lift driving lever 33735 B turn the feed shaft 33734 A. When the proper height is obtained, tighten the clamp screws and use a cement material for inserting the plug screw.

Looper Thread Take-up

The looper thread is controlled by a swinging type take-up system. It consists of the double cam 33723, the double thread eyelet 33757, the thread eyelet 33758 A on the looper drive lever, the thread control finger 33704, the thread eyelet 33758 B at the front right side of the cylinder and thread eyelet 11550 at the front left side of the cylinder near the looper (see threading diagram 17988 M).

The double cam 33723 is adjustably fastened with the ball stud nut and a screw on the needle driving lever. It can be turned radial and moved vertical to the lever after loosening the nut with wrench 21388 and the screw. The screw is accessible for the screw driver through a hole in the front side of the cylinder.

The double thread eyelet 33757 is fixed to the bed and is not adjustable. The thread control finger 33704 is adjustable up and down, and the thread eyelet 33758 A to the left and to the right.

When the looper returns from the left end of its travel to the right the notch of the cam should take-up the looper thread, should keep it from being slack and give it a slight tension on its further motion before it has dropped off the thread control finger after the needle has entered the triangle of the threads.

Threading of the Machine

Draw looper and needle threads into the machine according to threading diagram 17998 M and start operating on a piece of fabric.

Check the seam produced by unravelling the stitches and check if the threads are chafed or cut. If they are, apply a triangular oil stone to the tips of those feed dog teeth which are too sharp.

Thread Tension

The tension on the needle threads should only be sufficient to produce uniform stitches on the bottom side of the fabric.

The looper thread tension should be approximately one fourth of the tension which is applied to each needle thread.

Needle Thread Take-up

Set the frame needle thread eyelet in such a way that the fastening screw is in the middle of the slot. Set the needle thread take-up wire so that the thread of the right hand needle contacts the wire when the loop of the right needle is dropped from the looper.

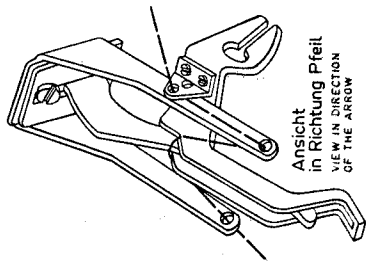

Ansicht
in Richtung Pfeil
VIEW IN DIRECTION
OF THE ARROW

Der Nadelhebelbolzen muß
so eingebaut sein, daß der
Pfeil nach oben zeigt.
THE NEEDLE LEVER STUD
MUST BE ASSEMBLED SO.

Hauptölbehälter
hier füllen.
FILL MAIN RESERVOIR HERE.

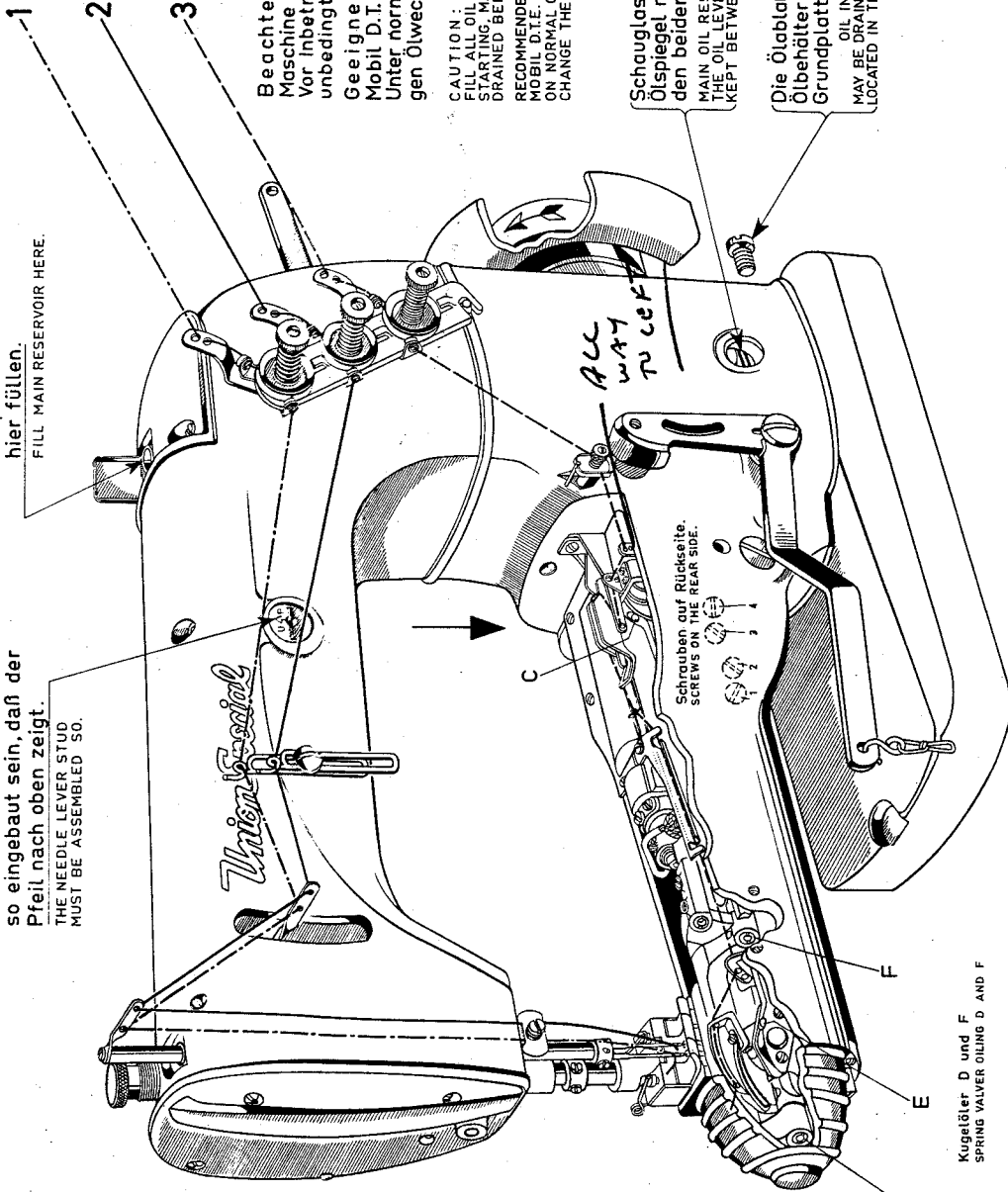

Beachte:
Maschine wird ohne Öl geliefert.
Vor Inbetriebnahme Behälter
unbedingt mit Öl füllen.
Geeignetes Öl:
Mobil D.T.E. Oil Medium.
Unter normalen Betriebsbedingun-
gen Ölwechsel 1* pro Jahr.

CAUTION:
FILL ALL OIL RESERVOIRS BEFORE
STARTING. MACHINE HAS BEEN
DRAINED BEFORE SHIPPING.

RECOMMENDED OIL:
MOBIL D.T.E. OIL MEDIUM.
ON NORMAL OPERATING CONDITIONS
CHANGE THE OIL ONCE A YEAR.

Schauglas für Hauptölbehälter.
Ölspiegel muß immer zwischen
den beiden roten Strichen sein.
MAIN OIL RESERVOIR GAUGE.
THE OIL LEVEL SHOULD BE
KEPT BETWEEN RED LINES.

Die Ölablaß-Schraube für Haupt-
ölbehälter befindet sich in der
Grundplatte unter dem Handrad.
OIL IN MAIN RESERVOIR
MAY BE DRAINED AT PLUG SCREW
LOCATED IN THE BASE PLATE.

Ölstellen A-F müssen pro
Woche 2* geölt werden.
OIL HOLES A-F MUST BE OILED
TWICE A WEEK.

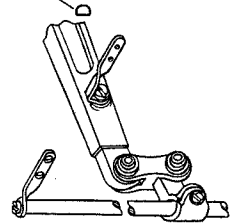

ÖL-UND EINFÄDELANLEITUNG FÜR MASCHINEN DER KLASSE 33700 A UND C
OILING-AND THREADING DIAGRAM FOR MACHINES CLASS 33700 A AND C

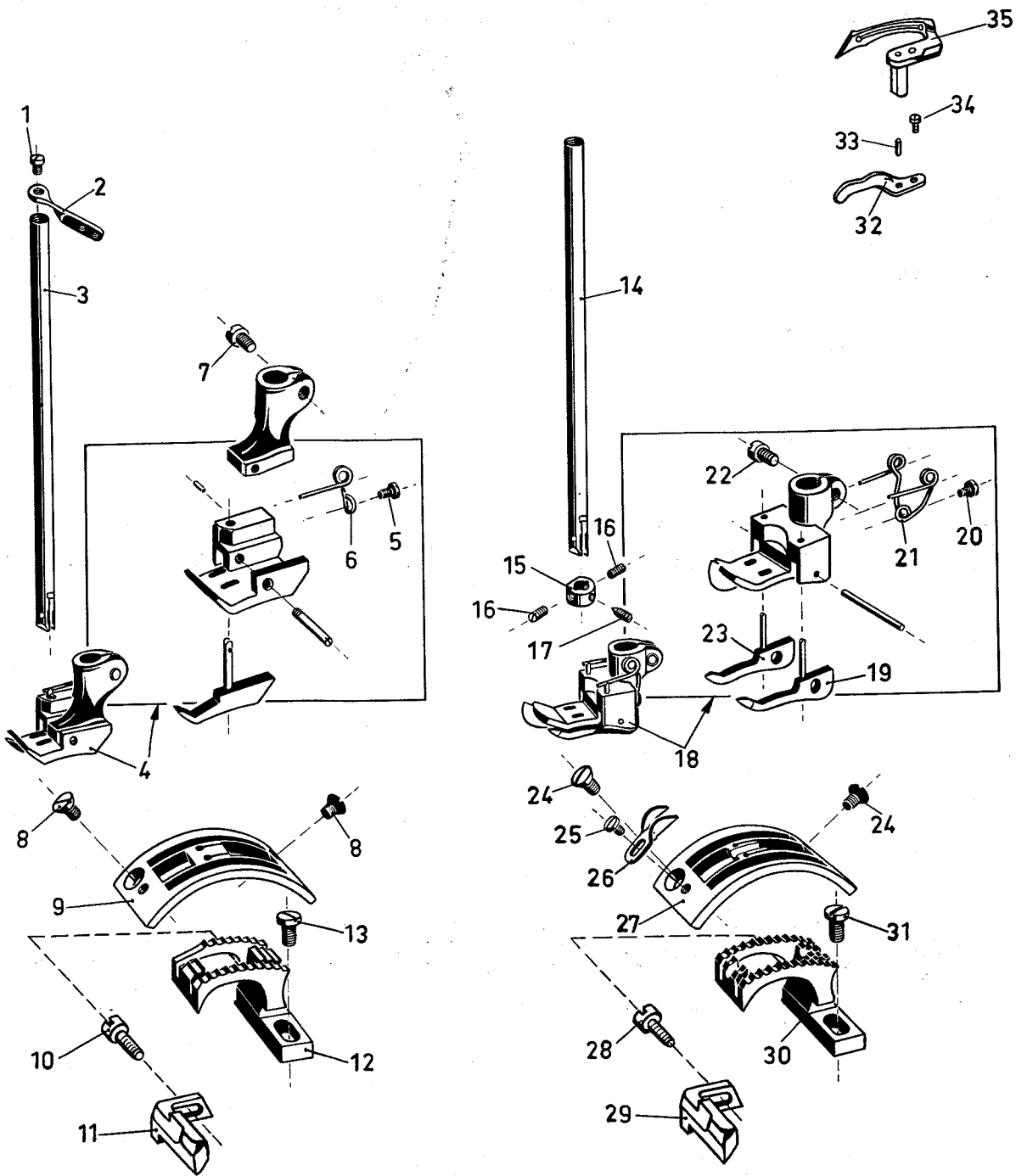

<u>Ref. No.</u>	<u>Part No.</u>	<u>Description</u>	<u>Amt. Req.</u>
1	22768	Screw	1
2	51458 51458A	Needle Lever Thread Eyelet	1
3	33717-16	Needle Bar	1
4	19320 A-16	Presser Foot complete	1
5	605	Screw	1
6	31546 A	Presser Foot Spring	1
7	91	Screw	1
8	87	Screw	2
9	19324 A-16 33724AO-16	Throat Plate	1
10	97	Screw	1
11	33725 A	Needle Guard	1
12	19305 A-16 33705AO-16	Feed Dog	1
13	93 A	Screw	1
14	33717-16	Needle Bar	1
15	12418	Needle Head	1
16	88 B	Screw	2
17	G 96	Screw	1
18	19320 C-16	Presser Foot	1
19	10642 B	Yielding Side, right	1
20	605	Screw	1
21	11940 A	Presser Foot Spring	1
22	91	Screw	1
23	10642 A	Yielding Side, left	1
24	87	Screw	2
25	187 A	Screw	1
26	23404 L	Seam Guide	1
27	19324 C-16 19324 ^{OIC} C-16	Throat Plate	1
28	97	Screw	1
29	33725 A	Needle Guard	1
30	19305 C-16	Feed Dog	1
31	93 A	Screw	1
32	729	Looper Needle Guard	1
33	1740	Pin	1
34	73 A	Screw	1
35	33709 B	Looper	1

can use this for
33724 AO-16 BUT must
cut out front of
FD slot

5

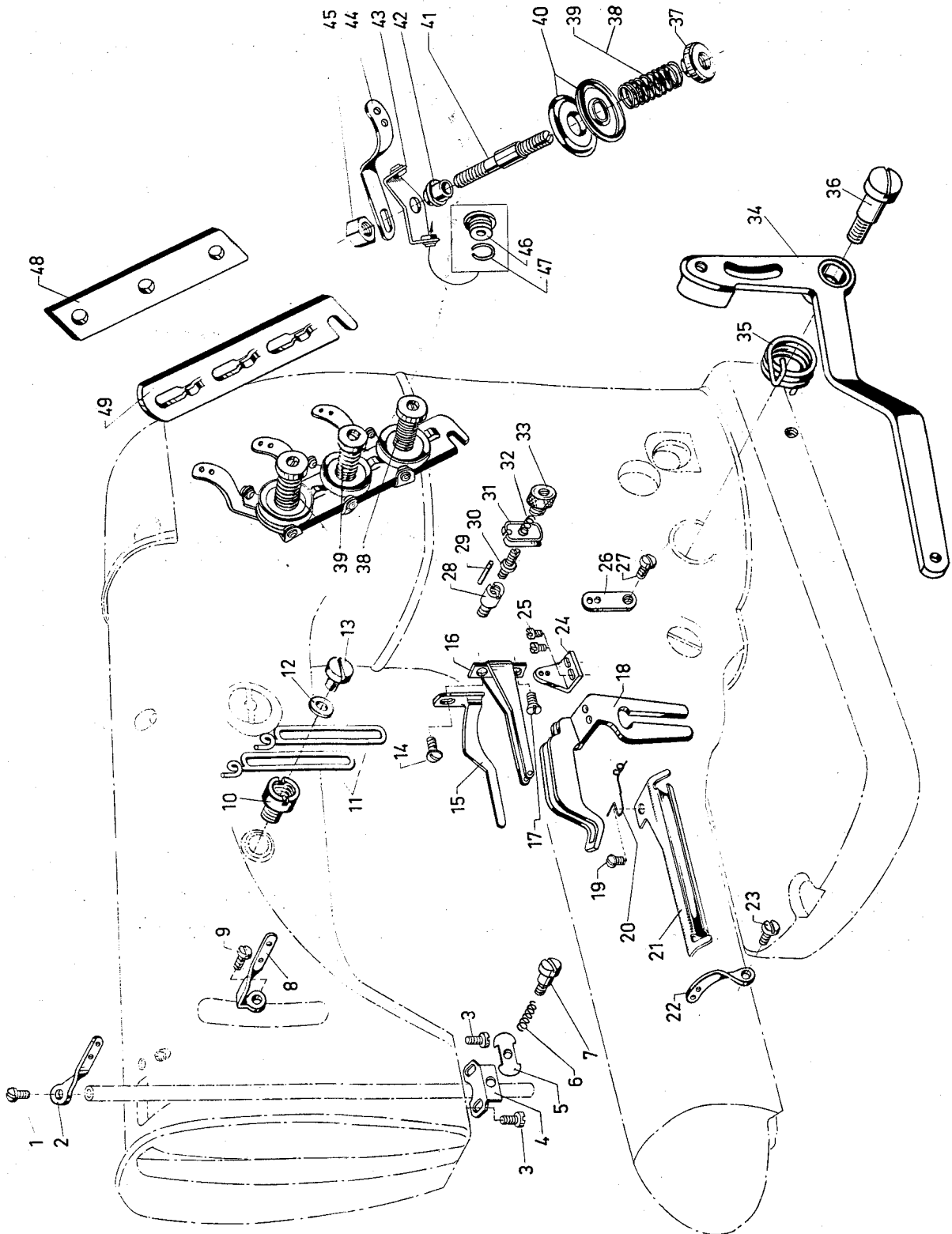

<u>Ref. No.</u>	<u>Part No.</u>	<u>D e s c r i p t i o n</u>	<u>Amt. Req.</u>
1	22768	Screw	1
2	51458 A	Needle Bar Thread Eyelet	1
3	J 87 J	Screw	2
4	33759	Nipper Spring Base	1
5	57 WB	Nipper Spring Plate	1
6	57 WC	Nipper Tension Spring	1
7	57 WD	Shoulder Screw	1
8	51458	Needle Lever Thread Eyelet	1
9	22768	Screw	1
10	22889 A	Adapter Screw	1
11	539	Frame Needle Thread Eyelet	2
12	20	Washer	1
13	22848	Screw	1
14	22849 A	Screw	1
15	33704	Looper Thread Pull-off	1
16	33757	Looper Thread Guide	1
17	22766	Screw	1
18	33723	Looper Thread Take-up	1
19	22849 A	Screw	1
20	33658 A	Looper Thread Guide	1
21	33758	Thread Channel Guide	1
22	33758 C	Cylinder Looper Thread Eyelet	1
23	22768	Screw	1
24	33758 A	Looper Thread Guide	1
25	73 A	Screw	2
26	33758 B	Looper Thread Guide	1
27	77 P	Screw	1
28	33792	Spacing Stud	1
29	G 50-153	Pin	1
30	G 1346 D	Thread Nipper Tension Post	1
31	51959 B	Thread Nipper Disc	2
32	51959 C	Thread Nipper Spring	1
33	51959 D	Thread Nipper Nut	1
34	33760 C	Lifter for Hemming Attachment (Class 33700 A)	1
35	23388 L	Torsion Spring (Class 33700 A)	1
36	90968	Screw (Class 33700 A)	1
37	51292 C	Tension Nut	3
38	51292 F-2	Tension Spring (Looper)	1
39	51292 F-8	Tension Spring (Needle)	2
40	109	Tension Disc	6
41	51292 G	Tension Post	3
42	51292 A	Tension Post Ferrule	3
43	51292 D	Tension Thread Eyelet	3
44	51491 C	Lead - in Thread Guide	3
45	43266	Nut	1
46	668-25	Eyelet	6
47	668-28	Locking Ring	6
48	52892	Tension Post Support	1
49	21657-3	Tension Disc Separator	1

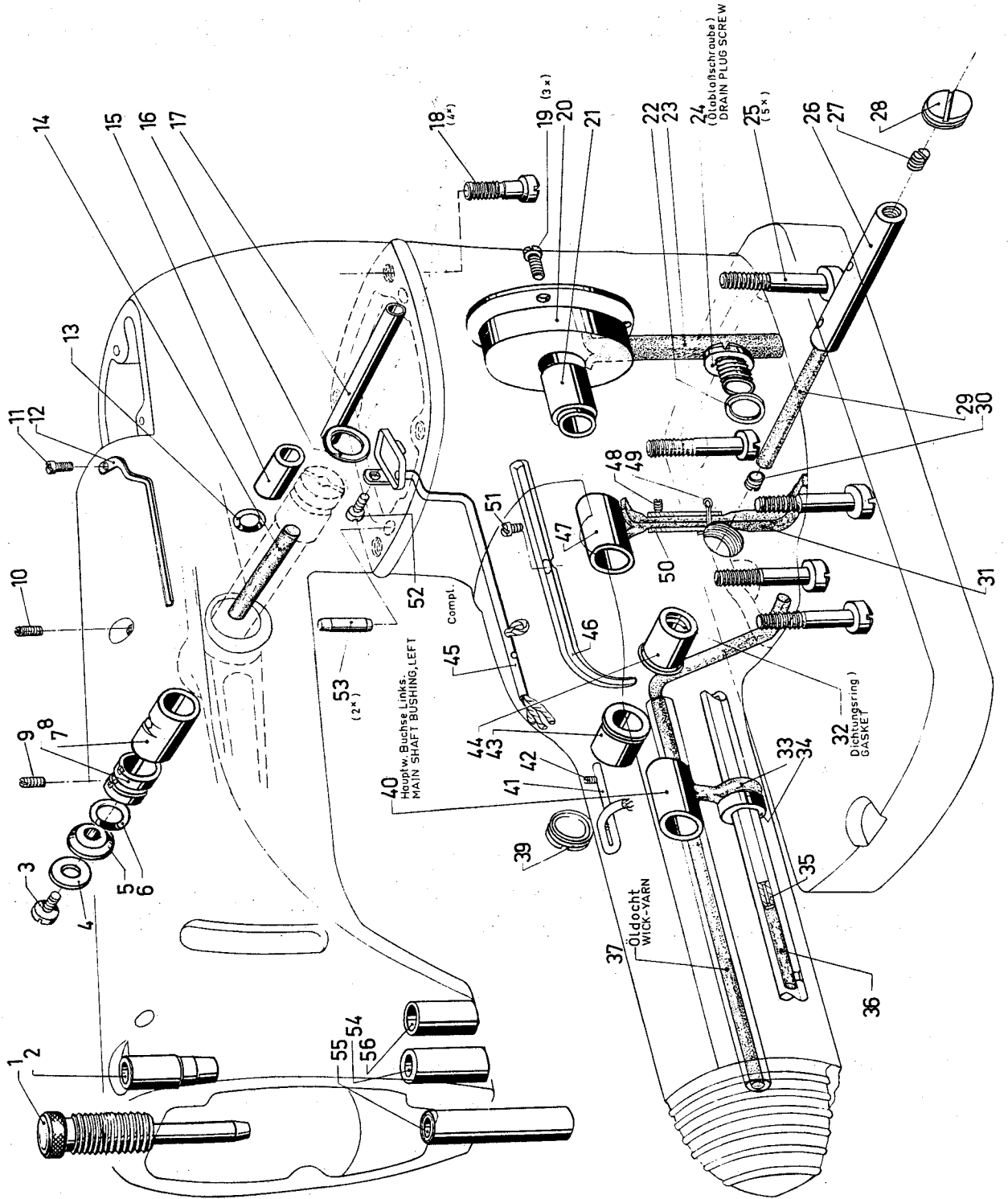

<u>Ref. No.</u>	<u>Part No.</u>	<u>Description</u>	<u>Amt. Req.</u>
1	51256 N	Presser Spring Regulating Stud	1
2	51254 C	Needle Bar Bushing	1
3	22586 R	Screw	1
4	51250 F	Gasket	1
5	51250 D	Washer	1
6	660-212	Oil Seal Ring	1
7	51250 A	Bushing	1
8	51150	Needle Lever Shaft Stop Collar	1
9	719	Screw	1
10	719	Screw	1
11	90	Screw	1
12	33782 AE	Needle Lever Bearing Oiler	1
13	660-207	Oil Seal Ring	1
14	666-170	Felt Wick	1
15	52883 R	Foot Lifter Lever Bushing	1
16	660-212	Oil Seal Ring	1
17	21657 X	Tension Release Lever Shaft Bushing	1
18	99274	Screw	4
19	22569 B	Screw	3
20	33791	Crankshaft Bearing Housing	1
21	33790 A	Bushing	1
22	41394 A	Gasket	2
23	999-4	Felt Oil Wick	1
24	22733 B	Plug Screw	1
25	90939	Screw	5
26	33742 II	Looper Drive Lever Shaft	1
27	22580	Screw	1
28	22539 C	Plug Screw	1
29	666-121	Oil Wick	1
30	22580	Screw	1
31	15430 L	Felt Wick	1
32	999-2	Gasket Ring	1
33	999-19	Felt	1
34	999-1	Retaining Ring	1
35	G 50-506	Oil Set	1
36	G 15430 L	Felt Wick	1
37	W 97	Wick-Yarn	1
39	22539 C	Plug Screw	1
40	33790 C	Main Shaft Bushing left	1
41	33794 C	Oil Tube	1
42	HA 73 B	Screw	1
43	33742 E	Bushing, rear	1
44	33742 C	Bushing, front	1
45	33794	Oil Tube	1
46	33794 A	Oil Channel	1
47	33790 B	Crankshaft Bushing middle	1
48	73 C	Screw	1
49	96300	Split Pin	1
50	33794 B	Oil Tube	1
51	22562	Screw	1
52	22585	Screw	1
53	80699 A	Dowel Pin	2
54	51254 D	Needle Bar Bushing Lower	1
55	33755 A	Presser Bar Bushing Lower	1
56	80273	Presser Foot Guide Bar Bushing	1

129
130

131

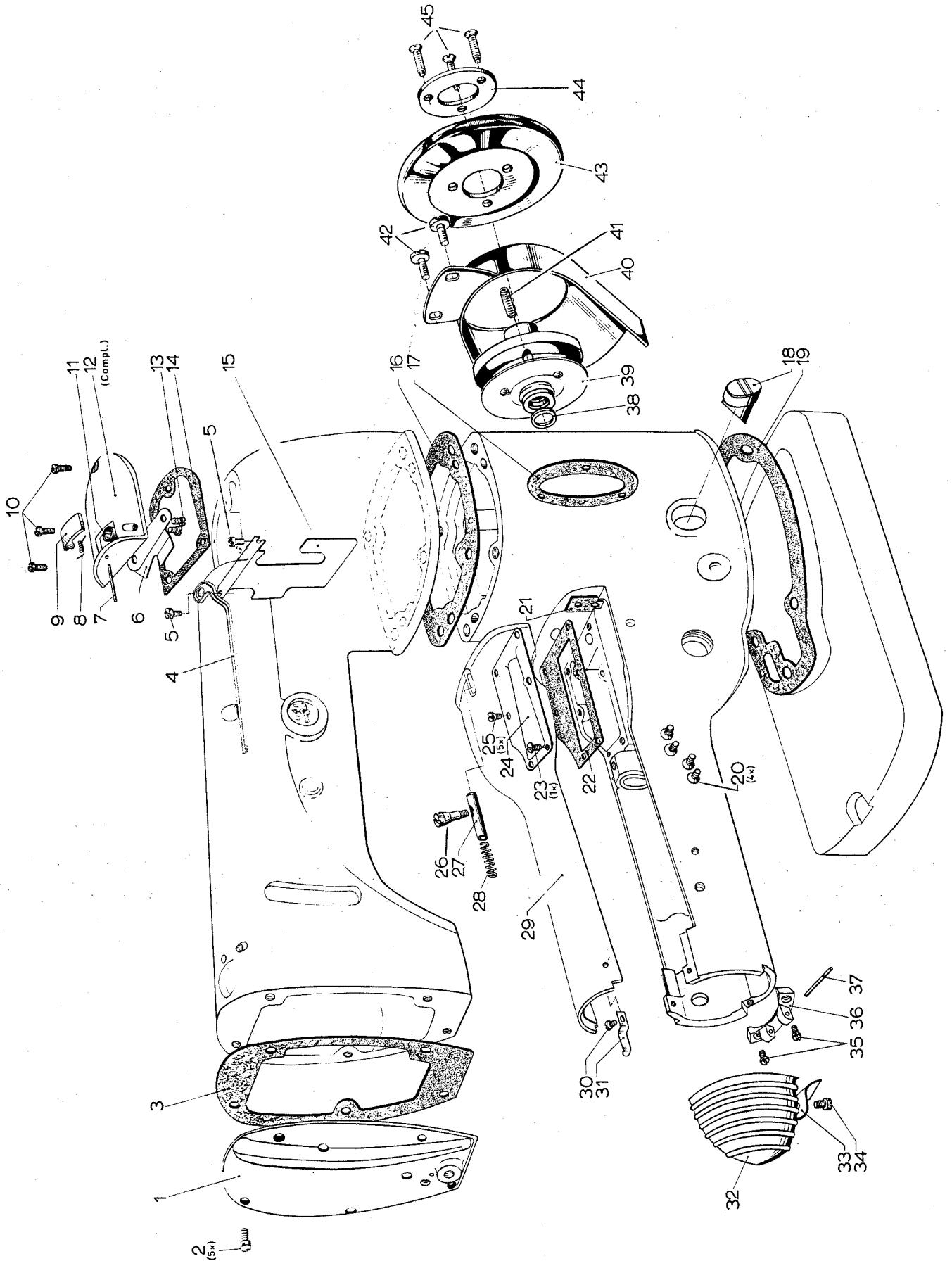

<u>Ref. No.</u>	<u>Part No.</u>	<u>D e s c r i p t i o n</u>	<u>Amt. Req.</u>
1	33782	Head Cover	1
2	22569	Screw	5
3	33782 A	Gasket	1
4	33782 AE	Needle Lever Bearing Oiler	1
5	90	Screw	2
6	52882 AA	Oil Drip Plate	1
7	50-789	Pin	1
8	52882 AC	Spring	1
9	39582 L	Oil Cap	1
10	22541 B	Screw	3
12	52882 AD	Crank Chamber Cover	1
13	90	Screw	2
14	52882 P	Gasket	1
15	33782 Y	Baffle Plate	1
16	33782 B	Gasket	1
17	51190 D	Gasket	1
18	G 50-434	Oil Sight Gauge	1
19	33782 K	Gasket	1
20	99273 A	Screw	4
21	33757 A	Gasket	1
22	33782 G	Gasket	1
23	22849	Screw	1
24	33782 F	Oil Reservoir Cover Plate	1
25	22766	Screw	5
26	525	Cylinder Cover Bolt Knob	1
27	523	Cylinder Cover Bolt	1
28	524	Spring	1
29	33785 C	Cylinder Cover	1
30	22564	Screw	1
31	33785 A	Spring	1
32	33785 B	Cylinder End Cap	1
33	G 353	Hinge Spring	1
34	357	Screw	1
35	97	Screw	2
36	352	End Cap Hinge	1
37	96851	Pin	1
38	660-202	Oil Ring	1
39	31121 A	Pulley	1
40	31175 B	Belt Guard	1
41	22894 G	Screw	1
42	22581	Screw	2
43	61321 J	Handwheel	1
44	61321 L	Washer	1
45	22574	Screw	3

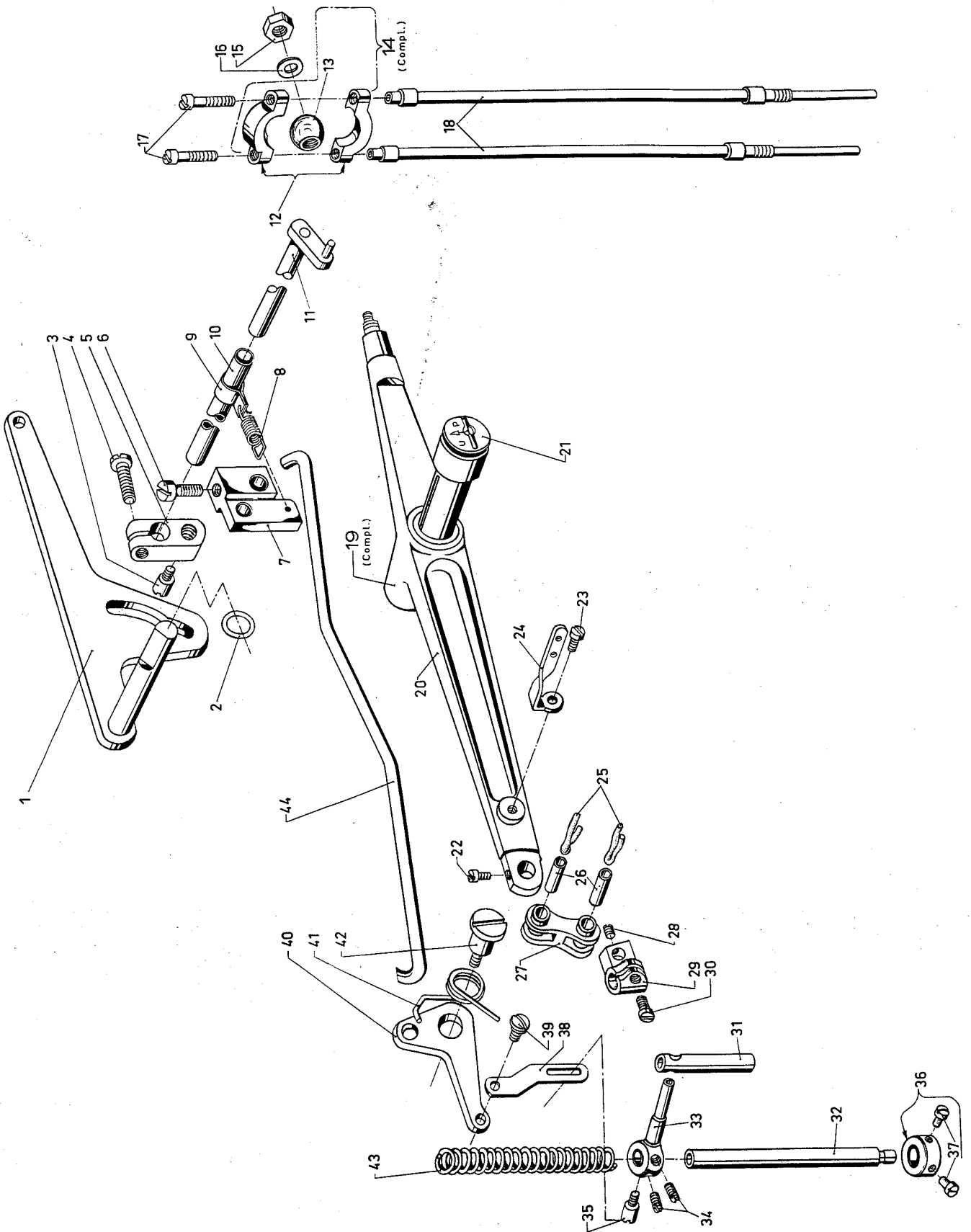

<u>Ref. No.</u>	<u>Part No.</u>	<u>D e s c r i p t i o n</u>	<u>Amt.Reg.</u>
1	33783 H	Presser Foot Lifter Lever	1
2	660-207	Oil Seal Ring	1
3	402	Screw	1
4	22596	Screw	1
5	21657 Y	Connection Link	1
6	318	Screw	1
7	33783 N	Lifter Lever internal	1
8	33783 T	Lifter Lever Return Spring	1
9	33783 U	Return Spring Holder	1
10	21657 X	Tension Release Lever Shaft Bushing	1
11	21657 W	Tension Release Lever Shaft	1
12	51216 K	Needle Lever Conn.Rod Bearing upper	1
13	51216 L	Ball Stud	1
14	29066 R	Needle Lever Connecting Rod Ball Joint Assembly upper	1
15	51216 P	Nut	1
16	51216 N	Washer	1
17	22559 G	Screw	2
18	33716 G	Needle Lever Connecting Rod	2
19	G 29348 C	Needle Lever Assembly	1
20	33715 D	Needle Lever	1
21	51250 E	Needle Lever Stud	1
22	77	Screw	1
23	22768	Screw	1
24	51458	Needle Lever Thread Eyelet	1
25	666-149	Lubricating Felt	2
26	51054	Link Pin	2
27	54	Needle Lever Link	1
28	78	Screw	1
29	51254 H	Needle Bar Connection	1
30	22562 A	Screw	1
31	33755	Presser Foot Guide Bar	1
32	51257 K	Presser Bar	1
33	33783	Presser Bar Connection	1
34	88	Screw	2
35	G 402	Shoulder Screw	1
36	52888 B	Presser Bar Stop Collar	1
37	22562	Screw	2
38	53783 A	Lifter Lever Link	1
39	22758 C	Screw	1
40	53783 L	Lifter Lever Bell Crank	1
41	33783 S	Lifter Lever Bell Crank Spring	1
42	G 22557 B	Shoulder Screw	1
43	51256 C	Presser Spring	1
44	33783 M	Lifter Lever Connecting Rod	1



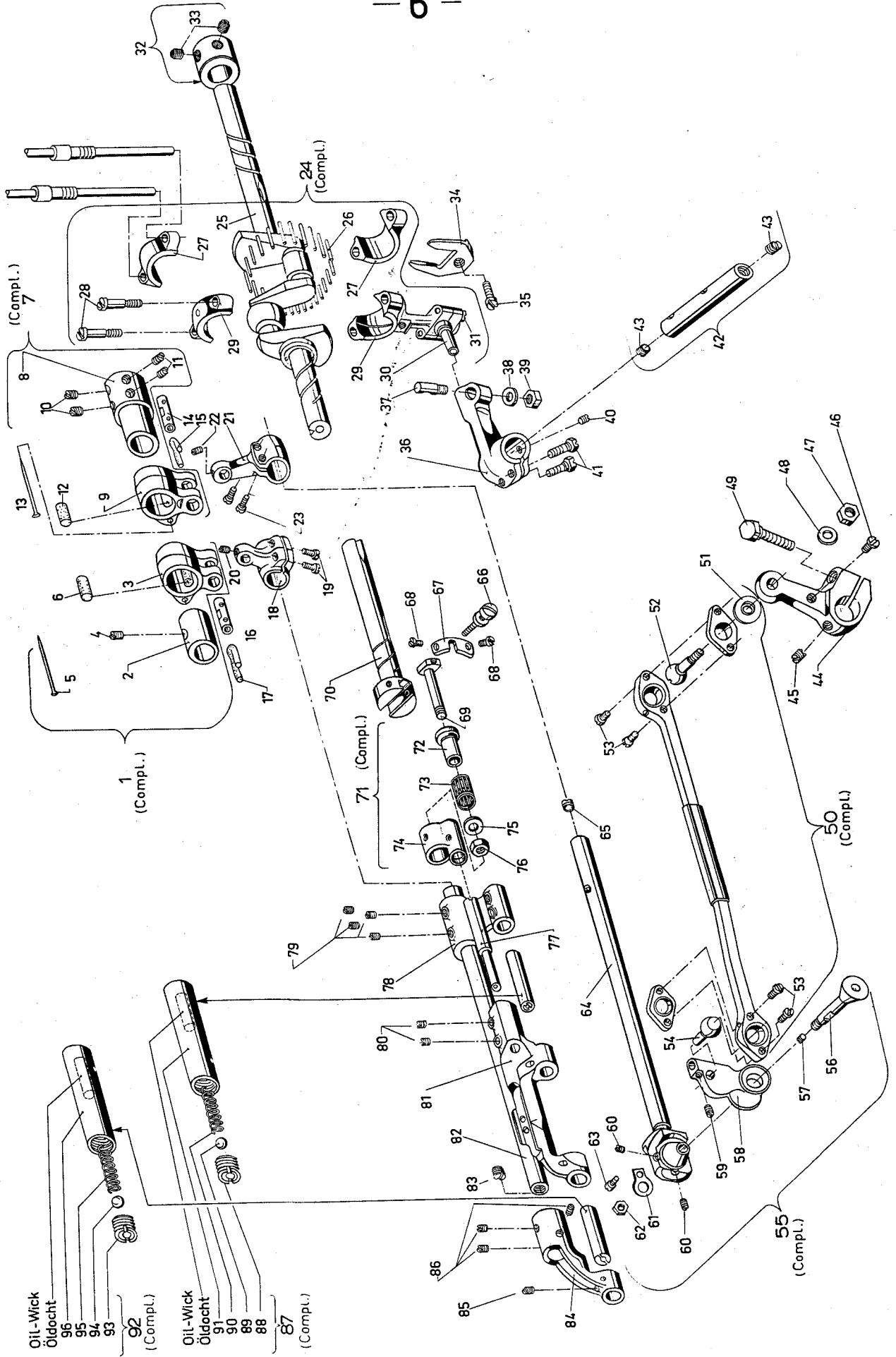

- Oil-Wick
- Öldocht
- 96
- 95
- 94
- 93
- 92 (Compl.)
- Oil-Wick
- Öldocht
- 91
- 90
- 89
- 88
- 87 (Compl.)

<u>Ref. No.</u>	<u>Part No.</u>	<u>Description</u>	<u>Am't. Req.</u>
1	G 29476 H	Feed Drive Eccentric and Link Assembly	1
2	33706	Eccentric	1
3	33735 C	Feed Drive Connecting Link	1
4	22894 D	Screw	1
5	P 1-18	Pin	1
6	666-82	Felt Wick	1
7	G 29476 GA	Looper Avoid Eccentric and Link Assembly	1
8	33714 A	Eccentric Sleeve	1
9	33745	Looper Avoid Connecting Link	1
10	22894 D	Screw	2
11	22894 D	Screw	2
12	666-82	Felt Wick	1
13	P 1-18	Pin	1
14	51236 A	Link Pin	1
15	666-149	Oil Wick	1
16	51236 A	Link Pin	1
17	666-149	Oil Wick	1
18	33735 B	Feed Drive Lever	1
19	22569 B	Screw	2
20	HA 73 B	Screw	1
21	33744 B	Looper Avoid Drive Lever	1
22	HA 73 B	Screw	1
23	22569 B	Screw	2
24	G 29476 T	Crankshaft and Needle Bearing Assembly	1
25	33722 E	Crankshaft	1
26	51216 M	Needle Bearing Roller	28
27	51216 J	Connecting Rod Bearing, lower	1
28	G 22559 C	Screw	2
29	33743	Looper Lever Bearing	1
30	33743 B	Ball Stud	1
31	97 A	Screw	2
32	33766	Stop Collar	1
33	22894 X	Screw	2
34	33743 A	Guide Fork	1
35	80175	Screw	1
36	33742 G	Looper Drive Lever	1
37	39243 H	Locking Stud	1
38	51242 M	Washer	1
39	18	Nut	1
40	89	Screw	1
41	99280	Screw	2
42	33742 H	Looper Drive Lever Shaft	1
43	22580	Screw	2
44	33742 A	Looper Drive Lever intermediate	1
45	96 B	Screw	1
46	22829 A	Screw	1
47	12538	Nut	1
48	21657 E	Washer	1
49	74 A	Screw	1
50	33737 A	Looper Lever Connecting Rod, compl.	1
51	33736	Ball Washer	1
52	33739 A	Ball Stud, right	1
53	22562	Screw	4
54	36 A	Ball Stud, left	1
55	G 29163 A	Looper Rocker Assembly	1
56	33733	Looper Rocker Cone	1
57	1096	Adjusting Screw	1
58	11513	Looper Rocker	1
59	22565	Screw	1
60	88	Screw	2
61	33744 C	Locking Washer	1
62	12982	Nut	1
63	77 A	Screw	1
64	33744	Looper Shaft	1
65	J 80 K	Locking Screw	1
66	82	Stitch Regulating Screw	1
67	304	Feed Crank Stud Cap	1
68	77 A	Screw	2
69	17	Feed Crank Stud	1
70	33722	Main Shaft	1
71	33745 A	Feed Crank Link Assembly	1
72	33745 B	Bushing	1
73	999-50	Needle Bearing	1
74	33745 A-1	Feed Drive Link	1
75	61434 G	Washer	1
76	18	Nut	1
77	305 A	Eccentric Stud	1
78	11743	Feed Rocker, right	1
79	98	Screw	4
80	88	Screw	2
81	33734	Feed Bar	1
82	33734 A	Feed Rocker Shaft	1
83	22706 A	Screw	1
84	11742	Feed Rocker, left	1
85	98	Screw	1
86	22580	Screw	2
87	33734 B	Feed Bar Driving Stud, right	1
88	80090 E	Plug Screw	1
89	12964 C	Ball	1
90	HA 1286 B	Spring	1
91	33734 B-1	Feed Bar Driving Stud	1
92	33734 C	Feed Bar Driving Stud, left	1
93	80090 E	Plug Screw	1
94	12964 C	Ball	1
95	HA 1286 B	Spring	1
96	33734 C-1	Feed Bar Driving Stud	1

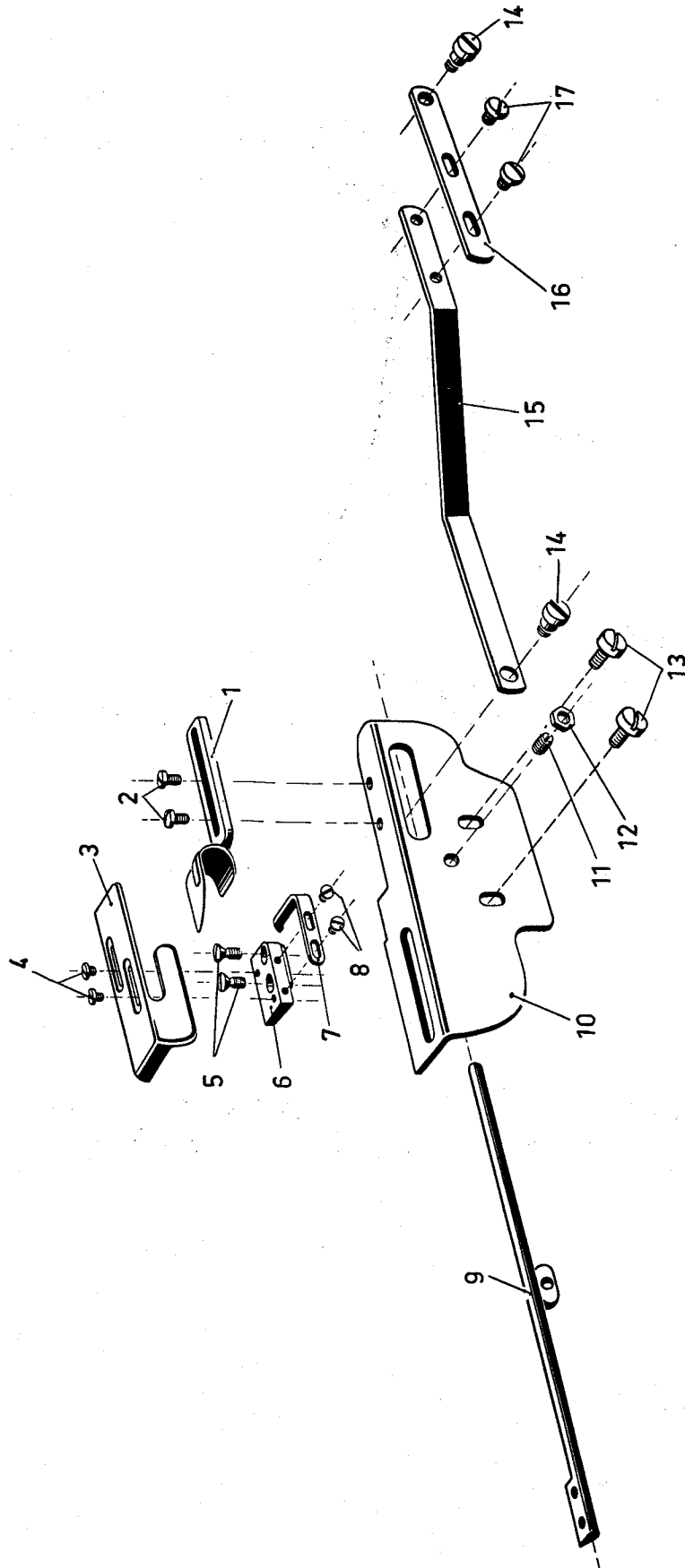

<u>Ref. No.</u>	<u>Part No.</u>	<u>D e s c r i p t i o n</u>	<u>Amt.Reg.</u>
	23389	Attachment, complete (Ref.No.1-12)	1
1	23388 C	Hemmer Scroll, adjustable	1
2	90	Screw	2
3	23389 B	Hemmer Tongue, adjustable	1
4	187 A	Screw	2
5	22524	Screw	2
6	23388 D	Hemmer Sliding Block	1
7	23388 E	Hemmer Edge Guide	1
8	605	Screw	2
9	23388 F	Hemmer Scroll Rod	1
10	23389 A	Hemmer Base	1
11	531	Screw	1
12	12934 A	Nut	1
13	22514	Screw	2
14	240	Link Stud	2
15	23388 J	Folder Rod	1
16	23388 K	Folder Rod Extension	1
17	25 CC	Screw	2

AUSRÜCKHEBEL FÜR APPARAT 23389 FÜR KNIEHEBELBETÄTIGUNG
LIFTER FOR SPLIT TUBE HEMMING ATTACHEMENT 23389
FOR KNEE PRESS-OPERATION FOR CLASS 33700 A

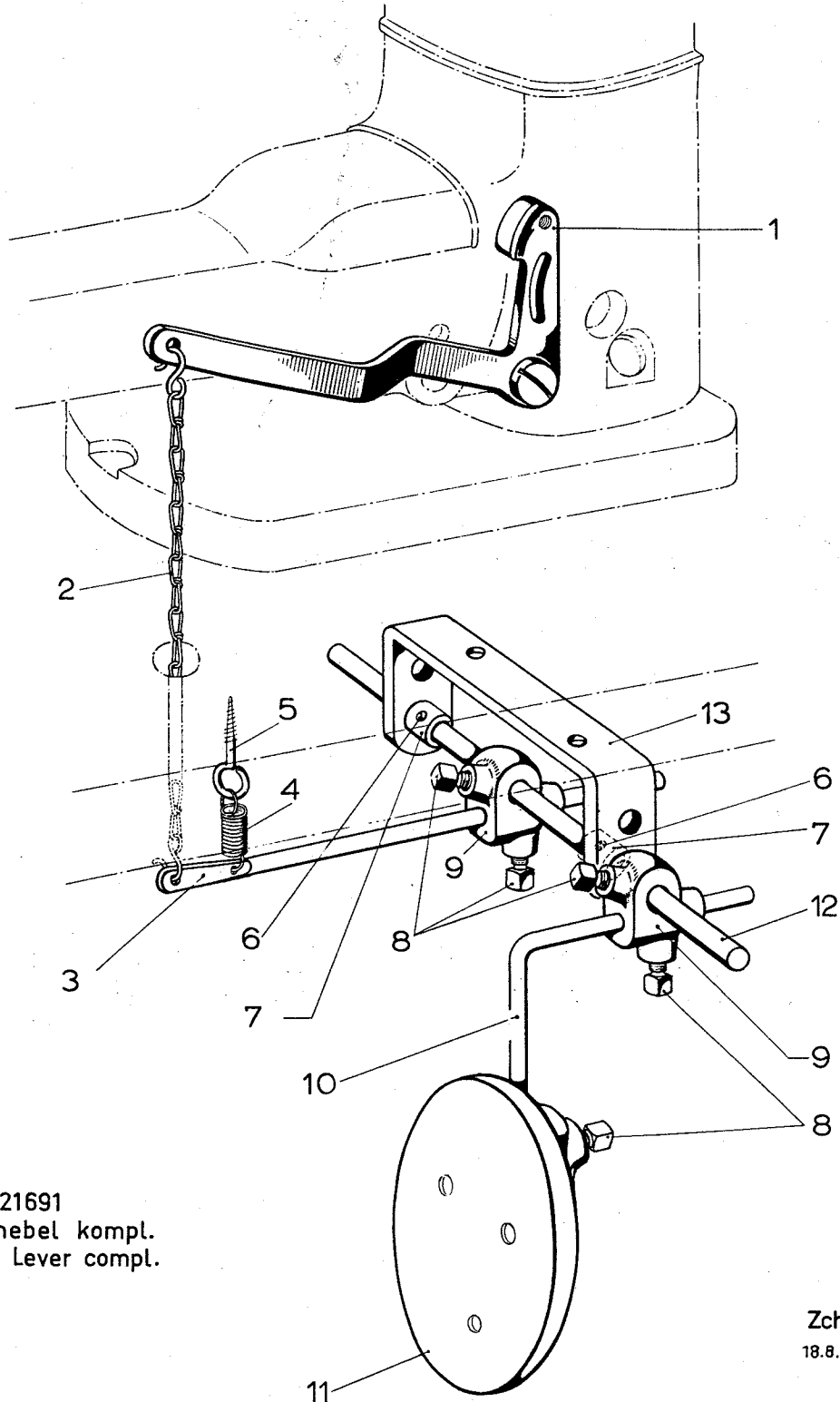

21691
Kniehebel kompl.
Knee Lever compl.

<u>Ref. No.</u>	<u>Part No.</u>	<u>D e s c r i p t i o n</u>	<u>Amt. Req.</u>
	21691	Knee Lever compl.	1
1	33760 C	Folder Operating Lever	1
2	421 D-10	Knee Press Chain	1
3	21679	Chain Rod	1
4	28505	Chain Rod Spring	1
5	660-128	Chain Rod Spring Screw Eye	1
6	98	Screw	2
7	9271	Collar	2
8	69 FD	Set Screw	5
9	21665	Chain Rod and Plate Connection	2
10	21677	Plate Rod	1
11	21664	Knee Press Plate	1
12	21661	Knee Press Bracket Shaft	1
13	21662	Knee Press Bracket	1

ÖLSIPHON / OIL SIPHON

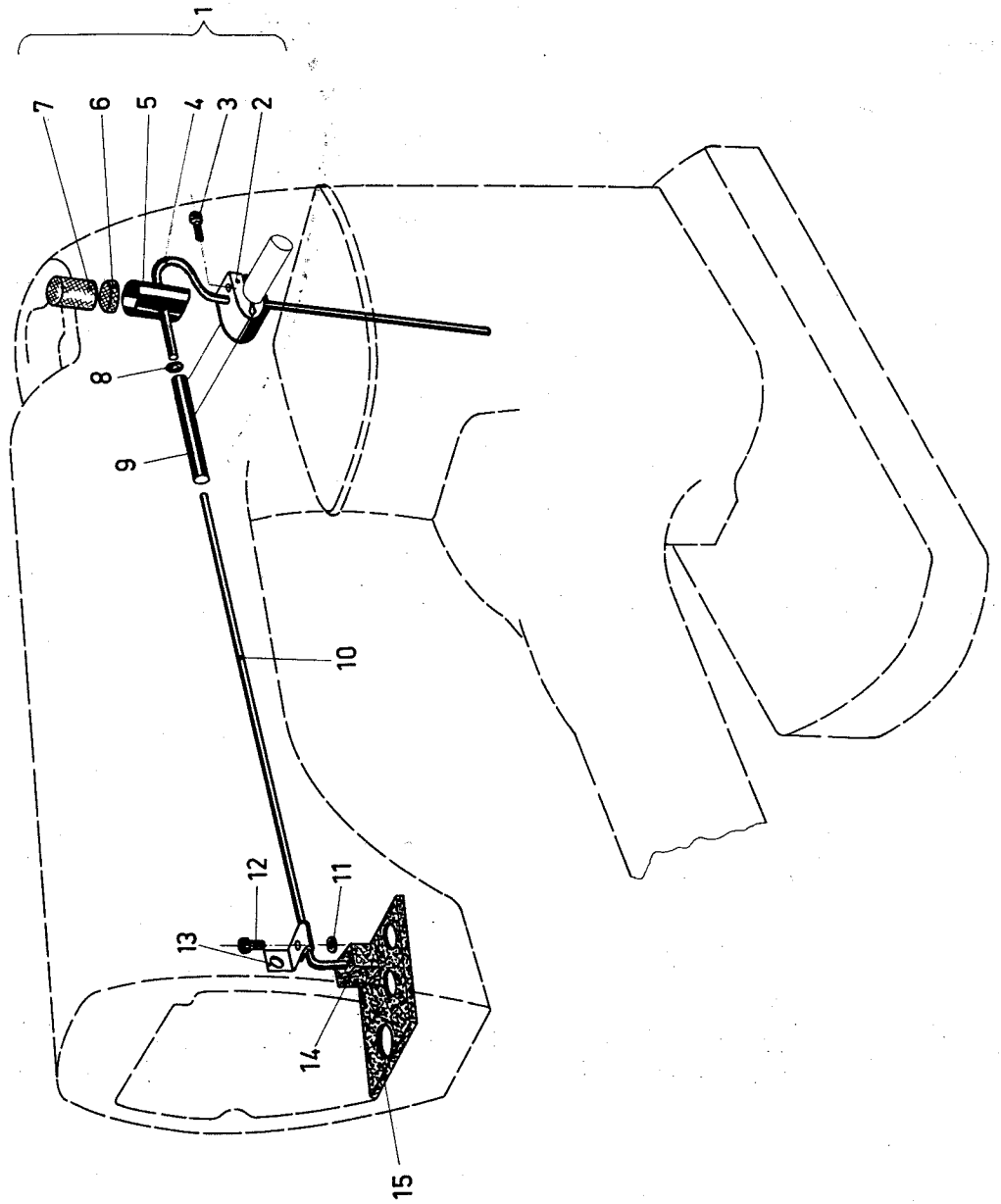

<u>Ref. No.</u>	<u>Part No.</u>	<u>D e s c r i p t i o n</u>	<u>Amt. Req.</u>
1	53394 P	Oil Siphon Assembly	1
2	53394 R	Oil Siphon Clamp	1
3	75	Screw	1
4	G 50-520	Oil Tube	1
5	G 50-521	Siphon	1
6	666-209	Siphon Cup Disc, felt	1
7	666-201	Felt Plug	1
8	21212	Oil Siphon Connection Locking	1
9	51294 N	Oil Tube Connection	1
10	31194	Oil Siphon Tube	1
11	43443 Q	Nut	1
12	87 U	Screw	1
13	31194 A	Oil Tube Clamp	1
14	666-214	Felt Lint Filter	1
15	31194 B	Felt	1

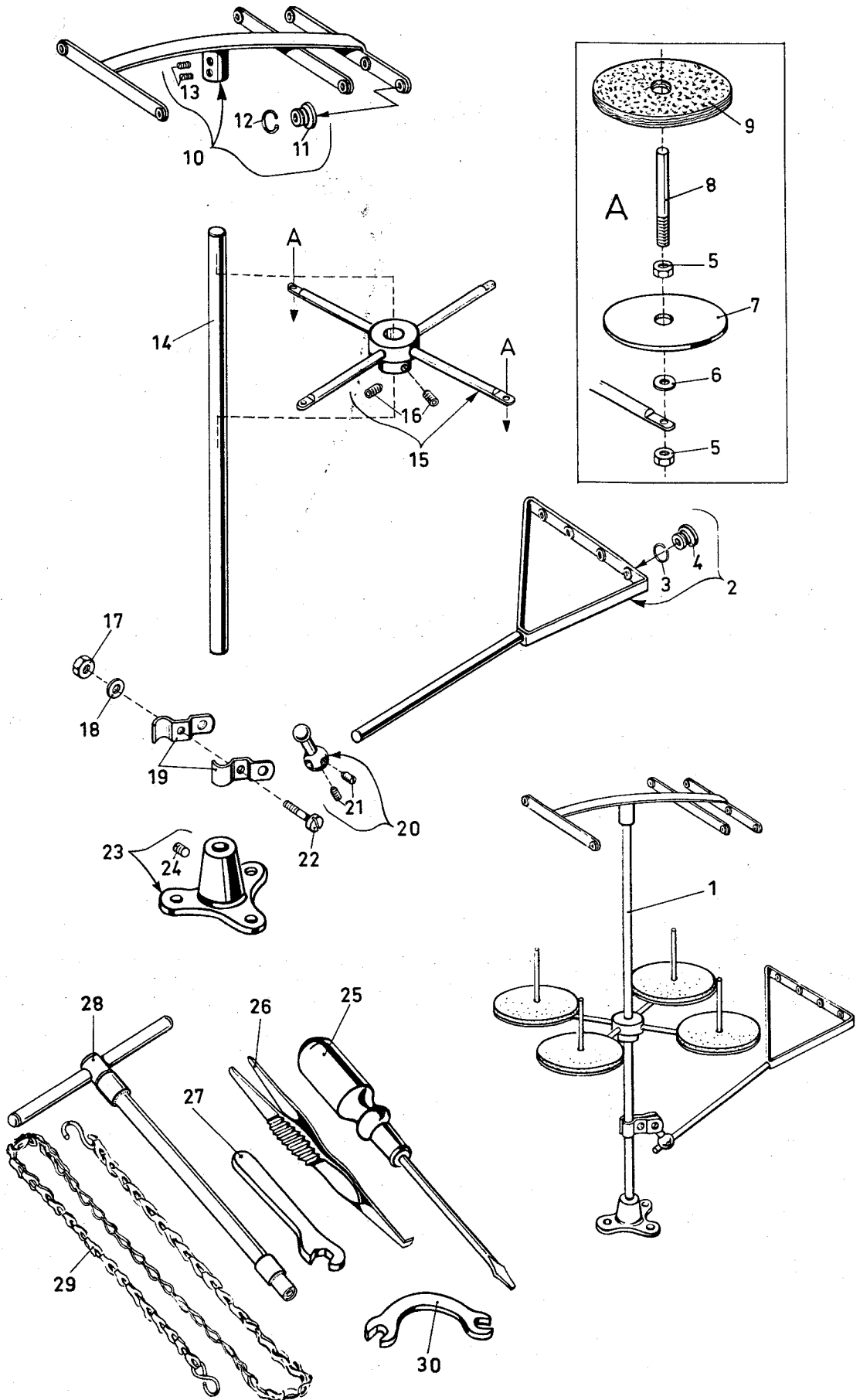

<u>Ref. No.</u>	<u>Part No.</u>	<u>Description</u>	<u>Amt. Req.</u>
1	21101 H-4	Thread Stand, complete	1
2	21114 S-4	Thread Stand Lead Eyelet	1
3	21114 M	Eyelet Locking Ring	4
4	21114 L	Eyelet	4
5	258 A	Nut	8
6	652-16	Washer	4
7	21114	Spool Seat Disc	4
8	21114 W	Spool Pin	4
9	21104 V	Pad, for thread	4
10	21114 H-4	Thread Stand Eyelet Support	1
11	21114 L	Eyelet	8
12	21114 M	Eyelet Locking Ring	8
13	22651 CD-4	Screw	2
14	21104 B-24	Thread Stand Rod	1
15	21114 D-4	Thread Stand Seat	1
16	22651 CD-5	Screw	2
17	21104 H	Nut	1
18	652-16	Washer	1
19	21114 U	Split Socket	2
20	21114 T	Lead Eyelet Socket Ball	1
21	22651 CD-4	Screw	2
22	22810	Screw	1
23	21114 A	Thread Stand Base	1
24	22651 CD-3	Screw	2
25	21201	Screw Driver, 9/64 inch round blade length over-all 7 5/8 inches	1
26	660-240	Tweezers	1
27	21388	Wrench, single end, 3/8 inch opening	1
28	21388 AE	Wrench 9/32 inch socket with extension	1
29	421 D-38	Treadle Chain	1
30	21388 W	Wrench, curved double end, 9/32 inch opening	1

NUMERICAL INDEX OF PARTS.

<u>Part No.</u>	<u>Page</u>	<u>Part No.</u>	<u>Page</u>	<u>Part No.</u>	<u>Page</u>	<u>Part No.</u>	<u>Page</u>
17.....	6	357.....	4	19305 A-16.....	1	22580.....	3,6
18.....	6	402.....	5	19305 C-16.....	1	22581.....	4
PI 18.....	6	G 402.....	5	19320 A-16.....	1	22585.....	3
20.....	2	421 D-10.....	8	19320 C-16.....	1	22586 R.....	3
25 CC.....	7	421 D-38.....	10	19324 A-16.....	1	22596.....	5
36 A.....	6	523.....	4	19324 C-16.....	1	22651 CD-3.....	10
G 50-153.....	2	524.....	4	21101 H-4.....	10	22651 CD-4.....	10
G 50-434.....	4	525.....	4	21104 B-24.....	10	22651 CD-5.....	10
G 50-506.....	3	531.....	7	21104 H.....	10	22706 A.....	6
G 50-520.....	9	539.....	2	21104 V.....	10	22733 B.....	3
G 50-521.....	9	605.....	1,7	21114.....	10	22758 C.....	5
50-789.....	4	652-16.....	10	21114 A.....	10	22766.....	2,4
54.....	5	660-128.....	8	21114 D-4.....	10	22768.....	1,2,5
57 WB.....	2	660-202.....	4	21114 H-4.....	10	22810.....	10
57 WC.....	2	660-207.....	3,5	21114 L.....	10	22829 A.....	6
57 WD.....	2	660-212.....	3	21114 M.....	10	22848.....	2
69 FD.....	8	660-240.....	10	21114 S-4.....	10	22849.....	4
73 A.....	1,2	666-82.....	6	21114 T.....	10	22849 A.....	2
HA 73 B.....	3,6	666-121.....	3	21114 U.....	10	22889 A.....	2
73 C.....	3	666-149.....	5,6	21114 W.....	10	22894 D.....	6
74 A.....	6	666-170.....	3	21201.....	10	22894 G.....	4
75.....	9	666-201.....	9	21212.....	9	22894 X.....	6
77.....	5	666-209.....	9	21388.....	10	23388 C.....	7
77 A.....	6	666-214.....	9	21388 W.....	10	23388 D.....	7
77 P.....	2	668-25.....	2	21388 AE.....	10	23388 E.....	7
78.....	5	668-28.....	2	21657-3.....	2	23388 F.....	7
J 80 K.....	6	719.....	3	21657-E.....	6	23388 J.....	7
82.....	6	729.....	1	21657 W.....	5	23388 K.....	7
87.....	1	999-1.....	3	21657 X.....	3,5	23388 L.....	2
87 U.....	9	999-2.....	3	21657 Y.....	5	23389.....	7
J 87 K.....	2	999-4.....	3	21661.....	8	23389 A.....	7
88.....	5,6	999-19.....	3	21662.....	8	23389 B.....	7
88 B.....	1	999-50.....	3	21664.....	8	23404 L.....	1
89.....	6	1096.....	6	21665.....	8	28505.....	8
90.....	3,4,7	HA 1286 B.....	6	21677.....	8	29066 R.....	5
91.....	1	G 1346 D.....	2,3	21679.....	8	G 29163 A.....	6
93 A.....	1,6	1740.....	1	21691.....	8	G 29348 C.....	5
96 B.....	6	9271.....	8	22514.....	7	G 29476 GA.....	6
G 96.....	1	10642 A.....	1	22524.....	7	G 29476 H.....	6
97.....	1,4	10642 B.....	1	22539 C.....	3	G 29476 T.....	6
W 97.....	3	11513.....	6	22541 B.....	4	31121 A.....	4
98.....	6,8	11742.....	6	G 22557 B.....	5	31175 B.....	4
109.....	2	11743.....	6	22559 G.....	5	31194.....	9
187 A.....	1,7	11940 A.....	1	G 22559 C.....	6	31194 A.....	9
240.....	7	12418.....	1	22562.....	3,5,6	31194 B.....	9
258 A.....	10	12538.....	6	22562 A.....	5	31546 A.....	1
304.....	6	12934 A.....	7	22564.....	4	33658 A.....	2
305 A.....	6	12964 C.....	6	22565.....	6	33704.....	2
318.....	5	12982.....	6	22569.....	4	33706.....	6
352.....	4	15430 L.....	3	22569 B.....	3,6	33709 B.....	1
G 353.....	4	G 15430 L.....	3	22574.....	4	33714 A.....	6

NUMERICAL INDEX OF PARTS.

<u>Part No.</u>	<u>Page</u>	<u>Part No.</u>	<u>Page</u>	<u>Part No.</u>	<u>Page</u>	<u>Part No.</u>	<u>Page</u>
33715 D.....	5	33757.....	2	39243 H.....	6	51959 B.....	2
33716 G.....	5	33757 A.....	4	39582 L.....	4	51959 C.....	2
33717-16.....	1	33758.....	2	41394 A.....	3	51959 D.....	2
33722.....	6	33758 A.....	2	43266.....	2	52882 AA.....	4
33722 E.....	6	33758 B.....	2	43443 Q.....	9	52882 AD.....	4
33723.....	2	33758 C.....	2	51054.....	5	52882 AC.....	4
33725 A.....	1	33759.....	2	51150.....	3	52882 P.....	4
33733.....	6	33760 C.....	2,8	51190 D.....	4	52883 R.....	3
33734.....	6	33766.....	6	51216 J.....	6	52888 B.....	5
33734 A.....	6	33782.....	4	51216 K.....	5	52892.....	2
33734 B.....	6	33782 A.....	4	51216 L.....	5	53394 P.....	9
33734 B-1.....	6	33782 B.....	4	51216 M.....	6	53394 R.....	9
33734 C.....	6	33782 F.....	4	51216 N.....	5	53783 A.....	5
33734 C-1.....	6	33782 G.....	4	51216 P.....	5	53783 L.....	5
33735 B.....	6	33782 K.....	4	51236 A.....	6	61321 J.....	4
33735 C.....	6	33782 Y.....	4	51242 M.....	6	61321 L.....	4
33736.....	6	33782 AE.....	3,4	51250 A.....	3	61434 G.....	6
33737 A.....	6	33783.....	5	51250 D.....	3	80090 E.....	6
33739 A.....	6	33783 H.....	5	51250 E.....	5	80175.....	6
33742 A.....	6	33783 M.....	5	51250 F.....	3	80273.....	3
33742 C.....	3	33783 N.....	5	51254 C.....	3	80699 A.....	3
33742 E.....	3	33783 S.....	5	51254 D.....	3	90939.....	3
33742 G.....	6	33783 T.....	5	51254 H.....	5	90968.....	2
33742 H.....	3,6	33783 U.....	5	51256 C.....	5	96300.....	3
33743.....	6	33785 A.....	4	51256 N.....	3	96851.....	4
33743 A.....	6	33785 B.....	4	51257 K.....	5	99273 A.....	4
33743 B.....	6	33785 C.....	4	51292 A.....	2	99274.....	3
33744.....	6	33790 A.....	3	51292 C.....	2	99280.....	6
33744 B.....	6	33790 B.....	3	51292 D.....	2		
33744 C.....	6	33790 C.....	3	51292 F-2.....	2		
33745.....	6	33791.....	3	51292 F-8.....	2		
33745 A.....	6	33792.....	2	51292 G.....	2		
33745 A-1.....	6	33794.....	3	51294 N.....	9		
33745 B.....	6	33794 A.....	3	51458.....	1,2,5		
33755.....	5	33794 B.....	3	51458 A.....	2		
33755 A.....	3	33794 C.....	3	51491 C.....	2		

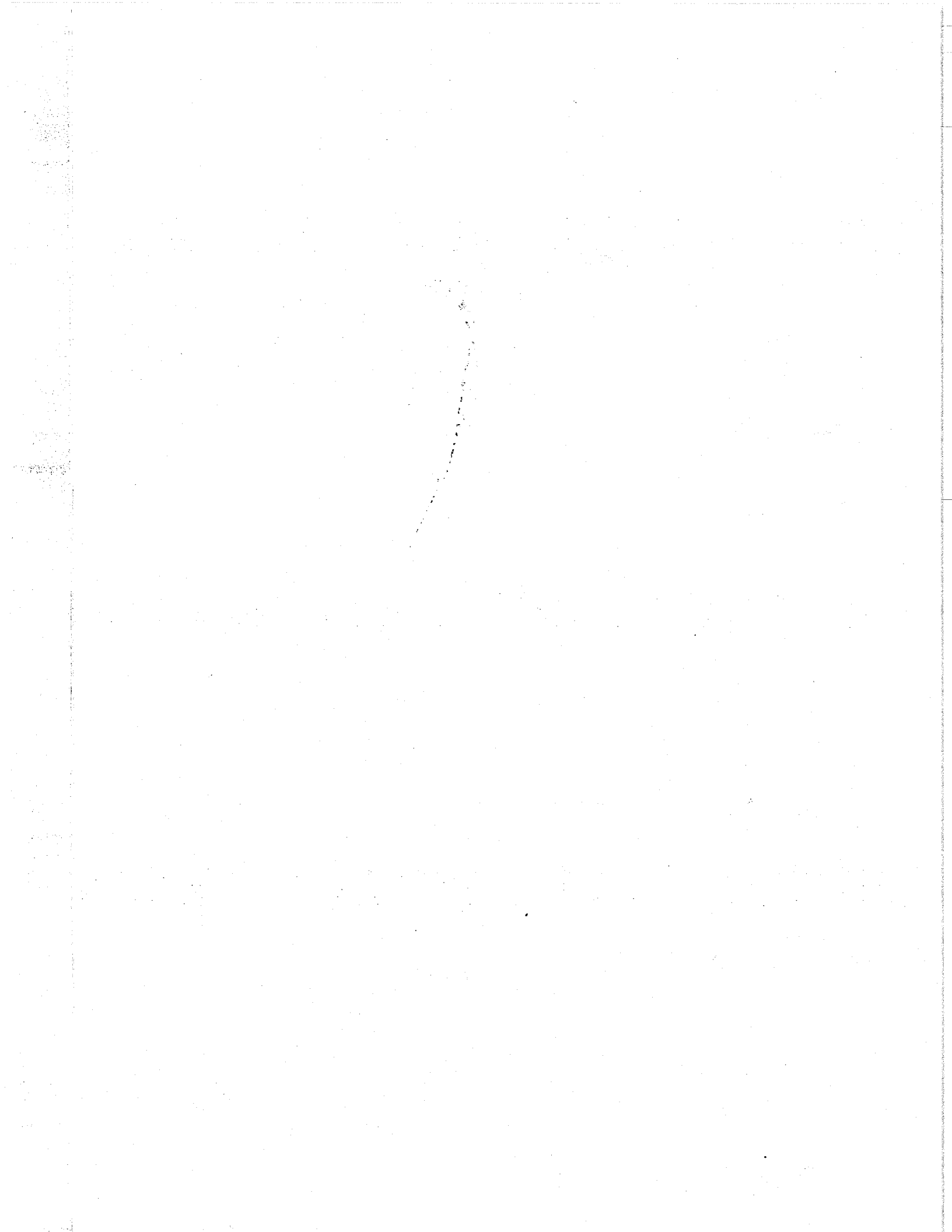

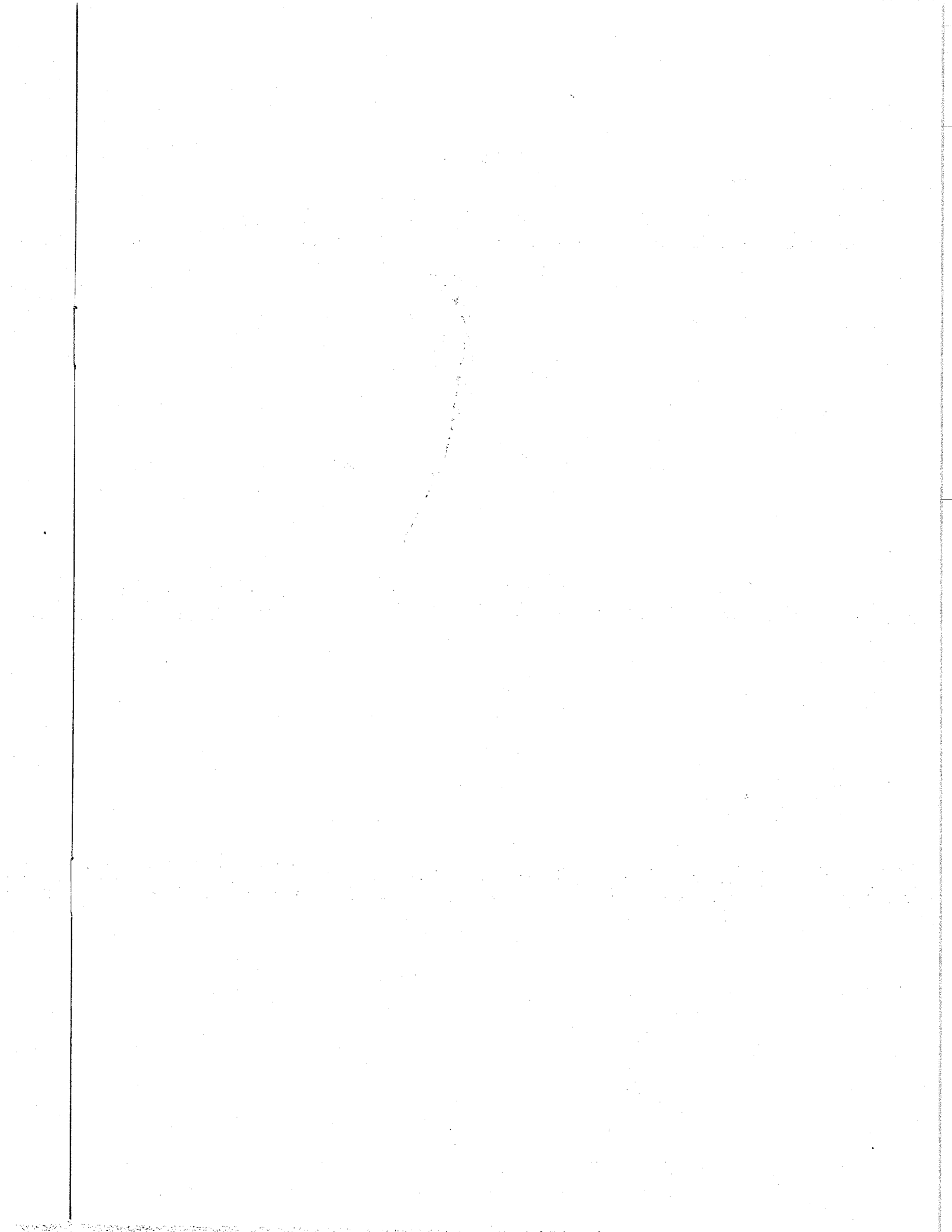

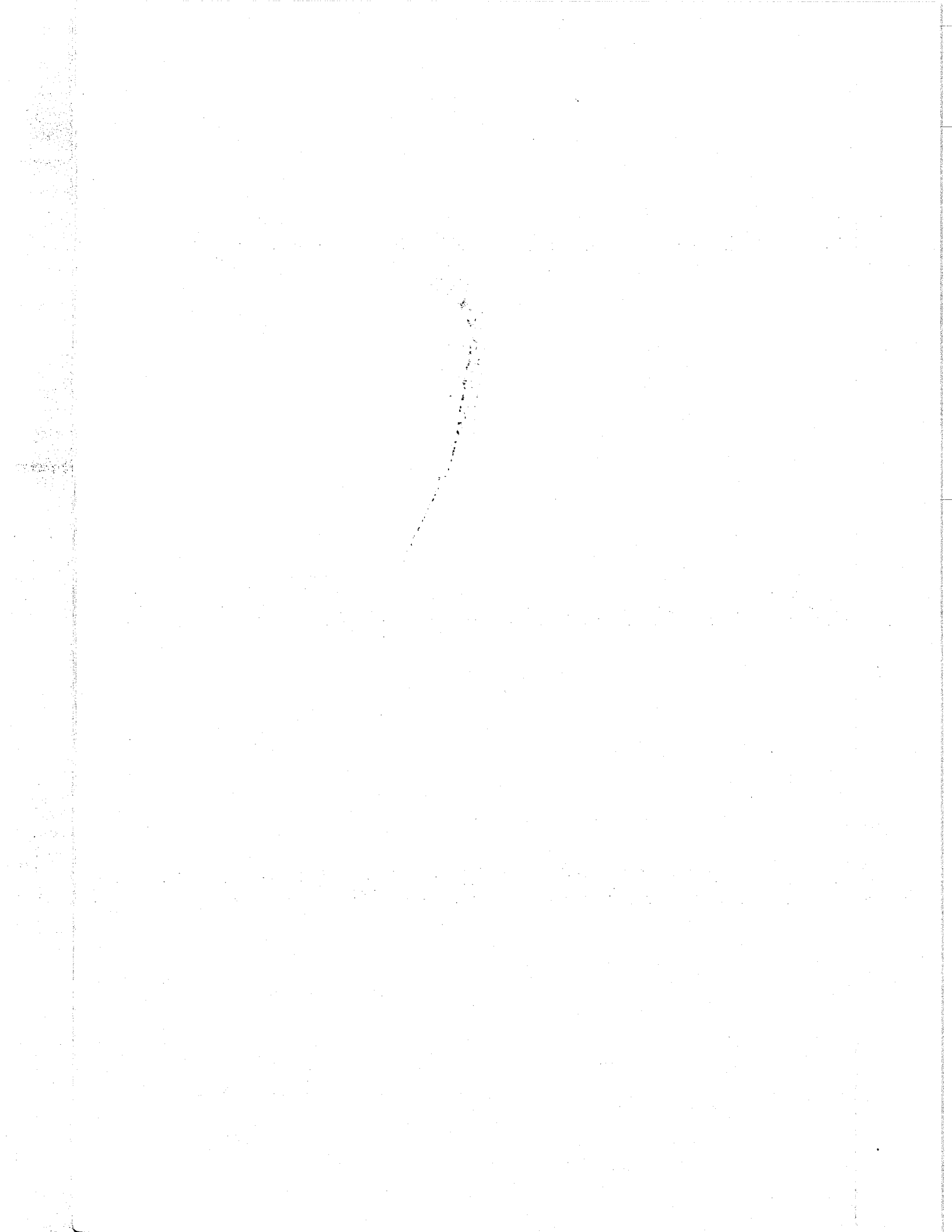

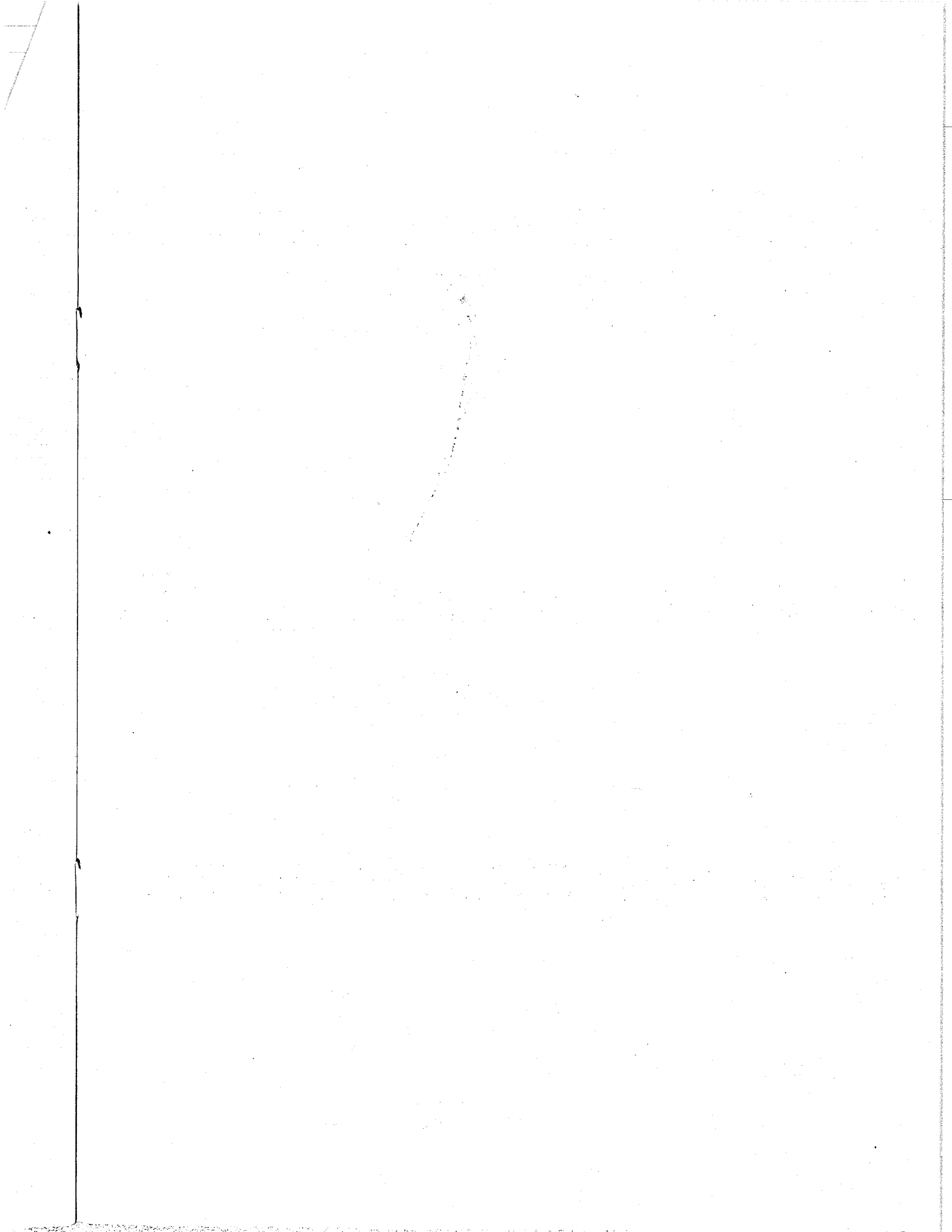



Union Special[®]
INDUSTRIAL SEWING MACHINES

UNION SPECIAL maintains sales and service facilities throughout the world. These offices will aid you in the selection of the right sewing equipment for your particular operation. Union Special representatives and service men are factory trained and are able to serve your needs promptly and efficiently. Whatever your location, there is a Union Special Representative to serve you. Check with him today.

ATLANTA, GA.

MONTREAL, CANADA

BOSTON, MASS.

TORONTO, CANADA

CHICAGO, ILL.

BRUSSELS, BELGIUM

DALLAS, TEXAS

LEICESTER, ENGLAND

LOS ANGELES, CAL.

LONDON, ENGLAND

NEW YORK, N. Y.

PARIS, FRANCE

PHILADELPHIA, PA.

STUTTGART, GERMANY

Representatives and distributors in all important industrial cities throughout the world.

Union Special
MACHINE COMPANY

Union Special[®]