

## Pneumatic Top and Bottom Thread Trimmer

# UT33

# PARTS LIST

13371802

No.1394-01

ALL PARTS NOT MENTIONED IN THIS PARTS LIST ARE SAME AS THOSE OF MODEL MF-7700. OTHER PARTS LIST RELATED TO THIS MODEL.

\*MF-7700 SERIES(NO.1375 PART NO.13370002)

### 1. THREAD TENSION COMPONENTS

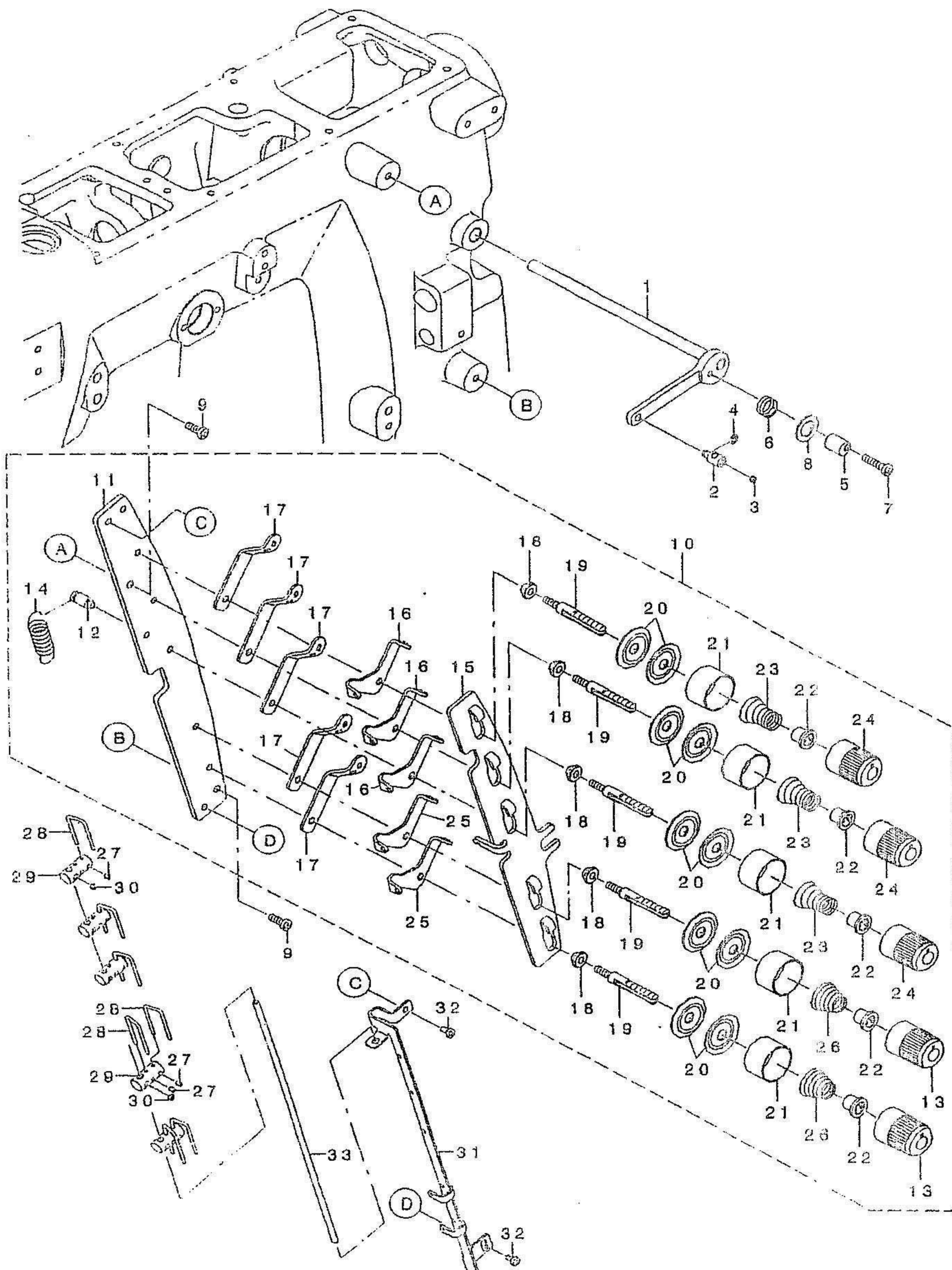



REF.NO	NOTE	PART NO.	DESCRIPTION	Qty
1		134-56553	PULL_OFF_LEVER_ASSY	1
2		134-56405	THD_PULL_OFF_BAR HOLDER	1
3		SM-8040360-TP	SCREW	1
4		RE-0300000-K0	E-RING 3	1
5		133-41409	TENS RELEASE ADJ ECC	1
6		133-41508	SPRING	1
7		SM-4041855-SP	SCREW M4 L=16	1
8		WP-0961046-SC	WASHER	1
9		SM-4041055-SP	SCREW	2
10		133-40252	THREAD TENSION ASSY	1
11		133-40203	TENSION POST SUPPORT	(1)
12		133-40302	SHOULDER SCREW	(1)
13		133-41706	KNOB	(2)
14		B2008-372-000	THREAD TENSION SPRING	(1)
15		133-40401	TENSION DISC SEPARATOR	(1)
16		133-41607	TENSION_DISC_EYELET_2	(3)
17		133-40609	THREAD LEAD IN GUIDE	(5)
18		133-40708	SPACER	(5)
19		133-40807	TENSION POST	(5)
20		229-28907	THREAD TENSION DISK	(10)
21		131-37609	THREAD TENSION DISK PRESSER	(5)
22		131-37906	SPRING BUSHING	(5)
23		131-40504	TENNSION SPRING	(3)
24		133-40906	KNOB GREEN	(3)
25		133-40500	TENSION DISC EYELET	(2)
26		B3121-804-000	TENSION SPRING	(2)
27		SM-8030412-TP	SCREW	7
28		134-56603	THD_PULL_OFF_HOOK	7
29		134-56207	THD_P_O_HOOK_GUIDE	5
30		SM-8040360-TP	SCREW	5
31		134-56009	THREAD_GUIDE	1
32		SM-4040855-SP	SCREW M4 L=6	2
33		134-56108	PULL_OFF_BAR	1

## 2. MISCELLANEOUS COVER COMPONENTS

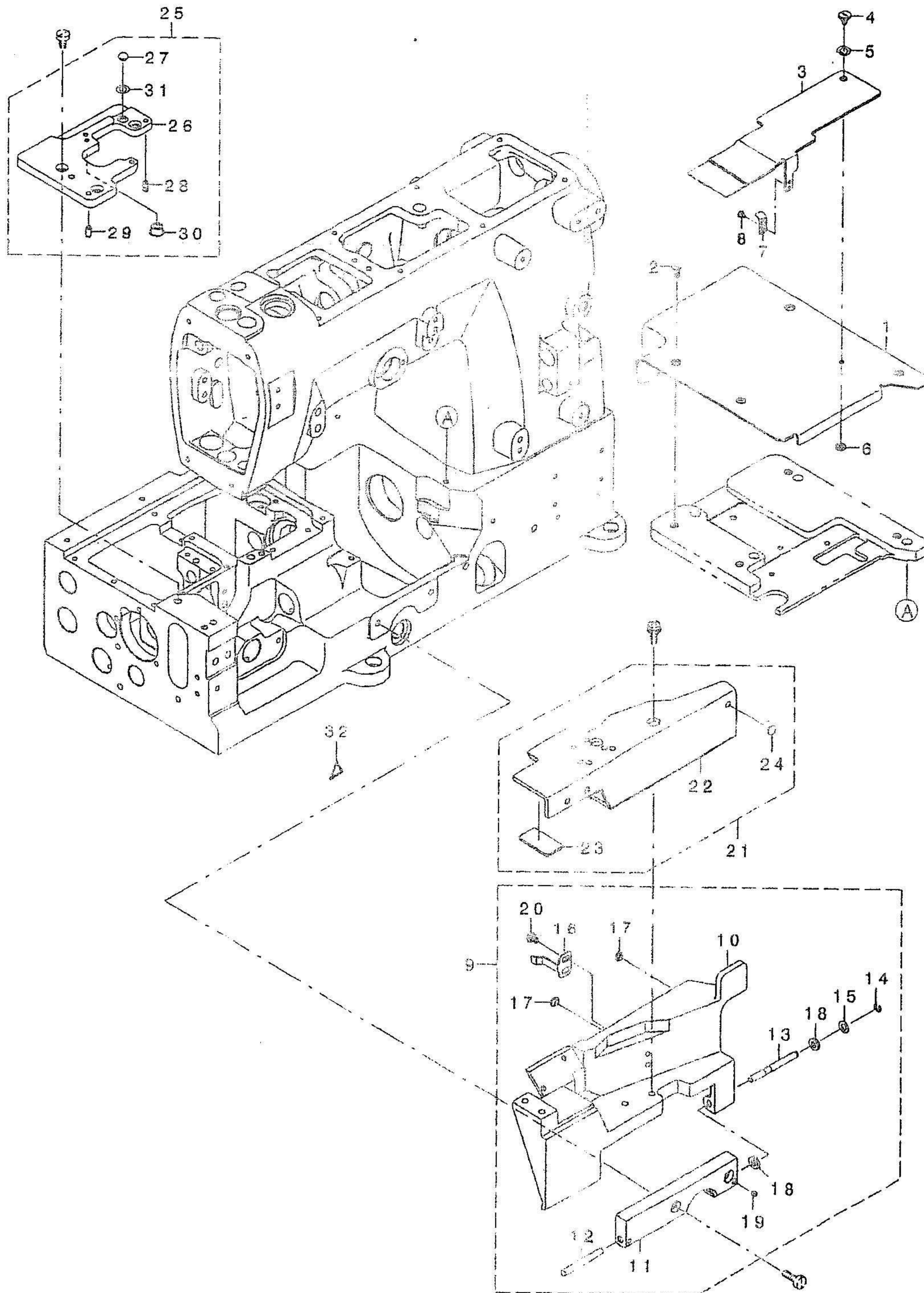



REF.NO	NOTE	PART NO.	DESCRIPTION	Qty
1		400-19324	COVER_A_UT	1
2		SM-1040800-SP	SCREW	4
3		400-19325	COVER_B_UT	1
4		SD-0600266-TP	SHOULDER SCREW D6 H2.5	1
5		WZ-0641510-KP	WAVED WASHER 6.4X11X0.3	1
6		NM-6040003-SD	NUT M4	1
7		400-19326	LATCH_SPRING_UT	1
8		SM-6850300-SP	SCREW M2.5 L=3	2
9		400-19330	ASSY_SWING_DOWN_COVER_UT	1
10		400-19329	SWING DOWN COVER UT	(1)
11		133-03508	HINGE	(1)
12		PH-0500400-CO	PARALLEL PIN	(1)
13		133-05206	PIN_FOR_S_D_COVER	(1)
14		RE-0300000-KO	E-RING 3	(1)
15		WP-0550800-SP	WASHER 5.5X10X0.8	(1)
16		133-04308	LATCH SPRING	(1)
17		133-02302	RUBBER BUMPER	(2)
18		133-02708	RUBBER_WASHER	(2)
19		SM-8040360-TP	SCREW	(2)
20		SM-4040655-SP	SCREW M4 L=6	(2)
21		400-19333	ASSY_BRACKET_UT	1
22		400-19332	BRACKET_UT	(1)
23		133-05305	RUBBER_BOARD	(1)
24		133-02302	RUBBER BUMPER	(1)
25		400-19327	ASSY_TP_SUPPORT_UT	1
26		133-03003	THROAT PLATE SUPPORT	(1)
27		133-02302	RUBBER BUMPER	(1)
28		133-01908	DOWEL PIN	(1)
29		133-02500	DOWEL PIN 2	(1)
30		TA-0850604-R0	RUBBER PLUG	(1)
31		WP-0531000-SD	WASHER M5	(1)
32		CM-3002000-01	ATTENTION SEAL	1

### 3. LOOPER THREAD TRIMMER COMPONENTS

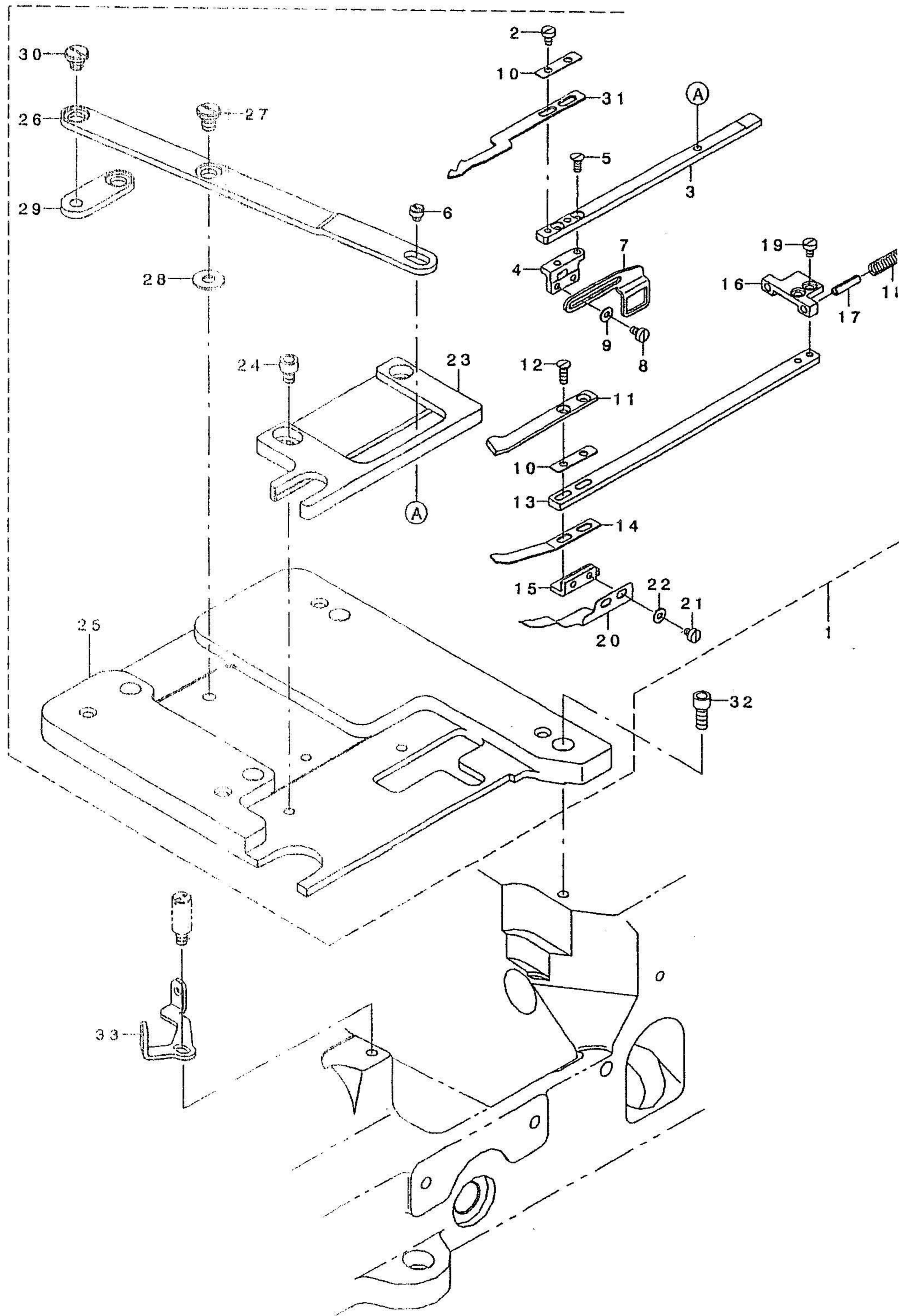



REF.NO	NOTE	PART NO.	DESCRIPTION	Qty
1		400-19336	ASSY_UNDER_TRIMMER_7700	1
2		SM-6850400-SP	SCREW M2.5 L=4	(2)
3		400-19305	LOWER_KNIFE_LEVER_UT	(1)
4		400-19306	LOWER_KNIFE_BRACKET_UT	(1)
5		SM-1850600-SP	SCREW	(2)
6		400-19307	LOWER_KNIFE_DRIVE_PIN_UT	(1)
7		400-19308	THREAD_TAKE_UP_UT	(1)
8		SM-6850400-SP	SCREW M2.5 L=4	(2)
9		WP-0250516-SD	WASHER 2.5X6X0.5	(2)
10		400-19309	PLATE WASHER UT	(2)
11		400-19310	UPPER_KNIFE_UT	(1)
12		SM-1850800-SP	SCREW M2.5 L=8	(2)
13		400-19311	UPPER_KNIFE_LEVER_UT	(1)
14		400-19312	KNIFE_SUPPORT_PLATE_UT	(1)
15		400-19313	UPPER_KNIFE_BRACKET_UT	(1)
16		400-19314	UPPER_KNIFE_STOPPER_UT	(1)
17		PS-0300122-KH	SPRING PIN 3X12	(2)
18		B1214-038-000	PLUNGER SPRING	(2)
19		SM-6850400-SP	SCREW M2.5 L=4	(2)
20		400-19315	THREAD_CLAMP_UT	(1)
21		SM-6850300-SP	SCREW M2.5 L=3	(2)
22		WP-0250516-SD	WASHER 2.5X6X0.5	(2)
23		400-19316	KNIFE_LEVER_GUIDE_UT	(1)
24		SM-6040502-TP	SCREW M4X0.7 L=5	(2)
25		400-19317	CLOTH_PLATE_RIGHT_UT	(1)
26		400-19318	LEVER_UT	(1)
27		SD-0600206-TP	SHOULDER SCREW	(1)
28		B3228-771-00B	BOBBIN WINDER SPACER	(1)
29		400-19319	LINK_UT	(1)
30		SD-0640216-TP	SHOULDER SCREW	(1)
31		400-19304	LOWER_KNIFE_UT	(1)
32		SM-6041002-TP	SCREW M4 L=10	4
33		400-19323	THREAD_GUIDE_UT	1



# 4. PNEUMATIC DRIVE & PRESSER FEED LIFTER COMPONENTS

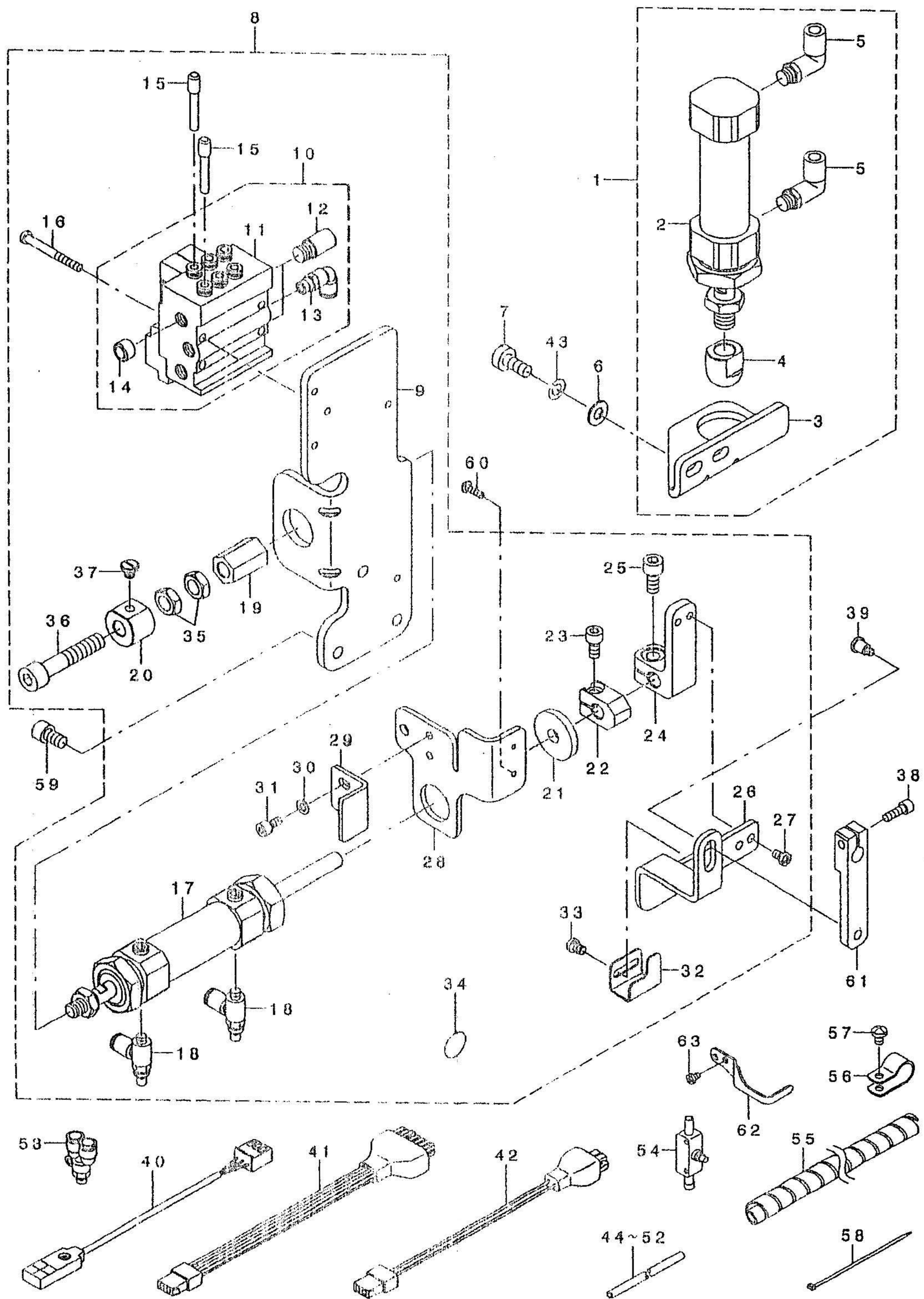



REF. NO	NOTE	PART NO.	DESCRIPTION	Qty
1		400-18079	PNEUMATIC_P_F_LIFTER_ASSY	1
2		PA-2503004-A0	AIR CYLINDER	(1)
3		134-55001	AIR_CYLINDER_BRACKET	(1)
4		134-55100	AIR_CYLINDER_CAP	(1)
5		PJ-3040451-02	ELBOW UNION, C	(2)
6		WP-0821016-SD	WASHER 6.2X13X1	2
7		SM-6061400-SP	SCREW M6 L=14	2
8		400-19337	ASSY_PNEUMATIC_DRIVE_7700	1
9		134-42504	AIR_CYLINDER_BRACKET	(1)
10		400-18080	MANIFOLD VALVE ASSY	(1)
11		PV-0351590-A0	MANIFOLD VALVE	(1)
12		PX-0551040-00	SILENCER (PT1/8)	(2)
13		PJ-3040651-01	ELBOW UNION 6XPT1/8	(1)
14		PJ-0251000-02	PLUG R1/8	(3)
15		PX-5000140-00	PLUG	(2)
16		SM-4043555-SP	SCREW	(2)
17		PA-2001802-A0	AIR CYLINDER	(1)
18		PC-0105080-00	SPEED CONTROLLER	(2)
19		400-19321	JOINT_B_UT	(1)
20		400-19320	JOINT_A_UT	(1)
21		134-43601	WASHER	(1)
22		134-42900	COLLAR	(1)
23		SM-6051002-TP	SCREW M5X0.8 L=10	(1)
24		134-43007	PLATE HOLDER	(1)
25		SM-6061202-TP	SCREW M6 L=12	(1)
26		400-19322	TENS_RELEASE_PLATE_UT	(1)
27		SM-4040655-SP	SCREW M4 L=6	(2)
28		134-42801	SENSOR HOLDER	(1)
29		134-43700	SUPPORT_PLATE_UT	(1)
30		WP-0430800-SC	WASHER M4	(2)
31		SM-6040802-TP	SCREW M4X0.7 L=8	(2)
32		134-43205	SWITCH_PLATE	(1)
33		SM-4040655-SP	SCREW M4 L=6	(2)
34		229-01805	GROUND MARK	(1)
35		NM-6080003-SD	BUT M8	(2)
36		SM-6084002-TN	SCREW M8 L=40	(1)
37		SD-0640216-TP	SHOULDER SCREW	(1)
38		SM-6041202-TP	SCREW M4X0.7 L=12	1
39		SD-0700706-TP	SHOULDER SCREW	1
40		400-21746	UNDER_TRIMMER_SENSOR_CABLE_ASM	1
41		400-18084	UNDER_TRIMMER_CABLE_ASM	1
42		400-18085	LIFT_UP_CABLE_ASM	1
43		WS-0610002-KP	SPRING WASHER	2
44		BT-0400251-EB	URETHANE HOSE, BLACK	0.27
45		BT-0400251-EB	URETHANE HOSE, BLACK	0.32
46		BT-0400251-EB	URETHANE HOSE, BLACK	0.08
47		BT-0400251-EB	URETHANE HOSE, BLACK	0.08
48		BT-0400251-EB	URETHANE HOSE, BLACK	0.42
49		BT-0400251-EB	URETHANE HOSE, BLACK	0.23
50		BT-0400251-EB	URETHANE HOSE, BLACK	0.63
51		BT-0400251-EB	URETHANE HOSE, BLACK	0.3
52		BT-0400251-EB	URETHANE HOSE, BLACK	0.22
53		PJ-3080400-06	UNION	2
54		PC-0124010-00	SPEED CONTROLLER	1
55		HX-0031400-0A	SPIRAL TUBE	0.6
56		HX-0015000-0D	CABLE CLIP	2
57		SM-4040655-SP	SCREW M4 L=6	2
58		EA-9500B01-00	CABLE BAND	3
59		SM-6061002-TP	SCREW M6 L=10	3
60		SM-4031001-SN	SCREW	1
61		134-43304	TENSION_RELEASE_LEVER	1
62		400-18259	RINGER_GUARD	1
63		SM-4030455-SP	SCREW	2



# 5. TOP COVER THREAD TRIMMER COMPONENTS

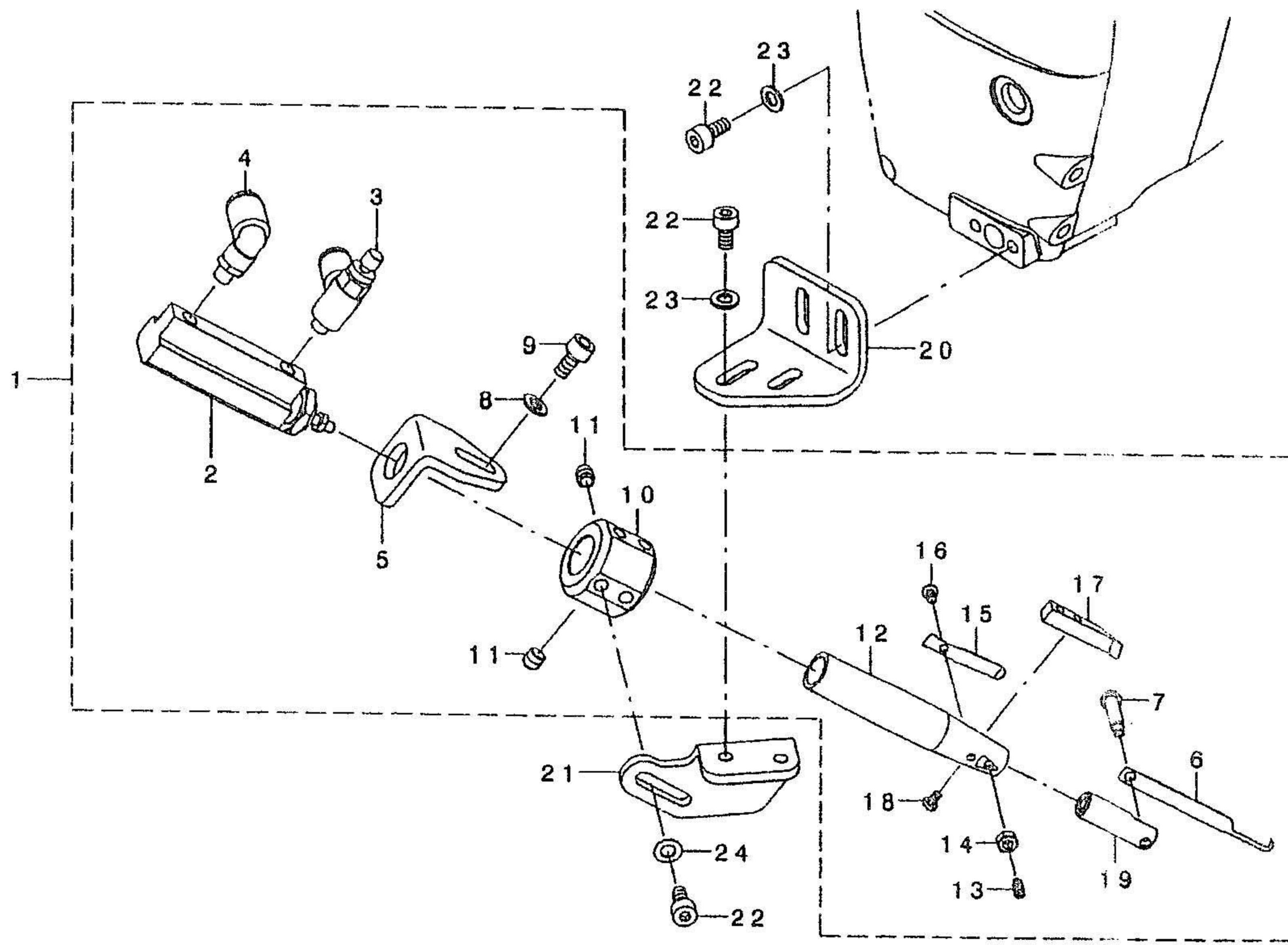



REF. NO	NOTE	PART NO.	DESCRIPTION	Qty
1		400-21279	U_L_THREAD_TRIMMER_ASSY	1
2		E2351-760-000	PIN CYLINDER	(1)
3		PC-0105080-00	SPEED CONTROLLER	(1)
4		PJ-3040405-04	ELBOW UNION	(1)
5		134-59300	AIR_CYLINDER_BRACKET	(1)
6		134-59003	MOVING_KNIFE	(1)
7		134-58104	SHOULDER_SCREW	(1)
8		WP-0430800-SC	WASHER M4	(2)
9		SM-6040802-TN	SCREW	(2)
10		134-58203	COLLAR	(1)
11		SM-8050512-TP	SCREW	(2)
12		134-58302	KNIFE HOLDER	(1)
13		SM-8030620-TP	SCREW	(1)
14		NM-6030001-SD	NUT M3X0.5	(1)
15		134-58401	SPRING	(1)
16		SM-4850455-SP	SCREW	(1)
17		134-58500	LOWER_KNIFE	(1)
18		SM-4850455-SP	SCREW	(2)
19		134-58005	MOVING_KNIFE HOLDER	(1)
20		134-58708	BRACKET_2	1
21		134-58609	BRACKET	1
22		SM-6040802-TN	SCREW	6
23		WP-0450826-SC	WASHER 4.5X10X0.8	4
24		WP-0430800-SC	WASHER M4	2



## 6. ACCESSORIE PART COMPONENTS

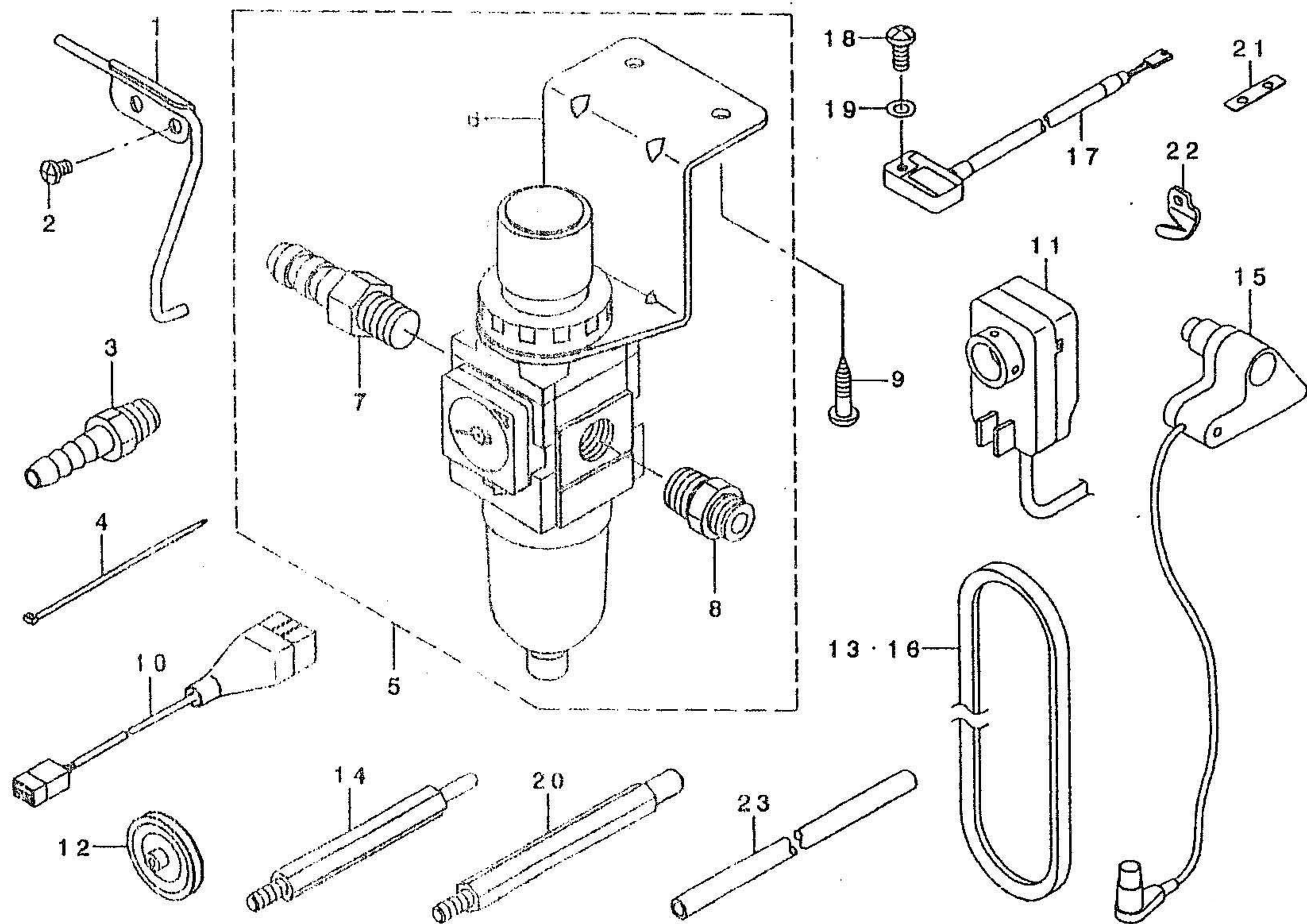



REF.NO	NOTE	PART NO.	DESCRIPTION	Qty
1		134-42058	AIR_BLOW_TUBE_ASSY	1
2		SM-4040655-SP	SCREW M4 L=6	2
3		PJ-0325260-01	HOSE NIPPLE	1
4		EA-9500B01-00	CABLE BAND	3
5		400-18052	FILTER REGULATOR ASSY	1
6		PF-0552070-C0	FILTER GEGULATOR	(1)
7		F1021-003-000	HOSE JOINT	(1)
8		PJ-3010652-01	HALF UNION 6XPT1/4	(1)
9		SK-3452001-SE	WOOD SCREW D=4.5 L=20	2
10	#01	400-21904	3P CONNECTER CONVERTER (ELCO TO	1
11	#01	MSC-M80000A0	SYNCHRONIZER ASM.	1
12	#01	MTS-P01200A0	MOTOR PULLEY ASM. P.C.D. 120	1
13	#01	MTJ-VM003600	V-BELT, 36 INCH	1
14	#01	133-08952	SYNCHRONIZER_STUD_ASSY	1
15	#02	GSY-010100A0	SY-1 UNIT A	1
16	#02	MTJ-VM003500	V-BELT, 35 INCH	1
17	#02	400-21727	RESISTOR PACK BL ASM.	1
18	#02	SM-4041055-SP	SCREW	1
19	#02	WP-0430800-SD	WASHER M4	1
20	#02	400-21897	SYNCHRONIZER STUD ASSY	1
21		400-19309	PLATE_WASHER_UT	1
22		133-16302	THREAD_TRIMMER	1
23		BT-0600401-EB	TUBE	2

Note #01....FOR SC-380  
#02....FOR SC-500