

Union Special

INDUSTRIAL SEWING EQUIPMENT

ILLUSTRATED PARTS LIST

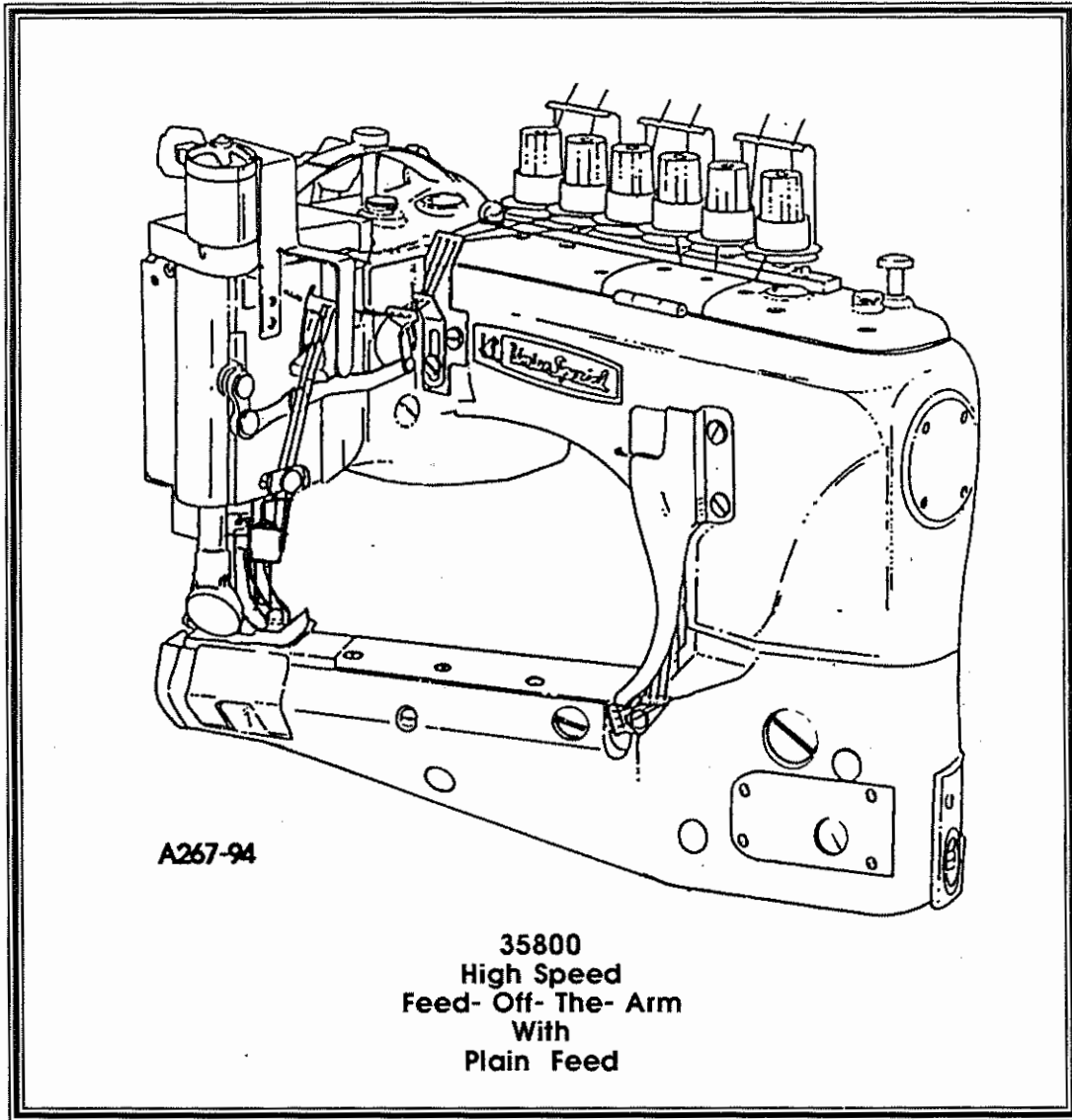

A267-94

35800
High Speed
Feed- Off- The- Arm
With
Plain Feed

MANUAL NO. PT9410

STYLES

35800DQW
35800DRW
35800DRWL

LEU1
35800 BX
DWWP9

Hopkinsville
800-826-9200

Manual No. PT9410 Illustrated Parts List for 35800 Series Machines

Fourth Edition Copyright 1994

By

Union Special Corporation Rights Reserved In All Countries

Printed in U.S.A. June 1994

PREFACE

This parts manual has been prepared to assist you in locating individual parts or assemblies on 35800 Series machines. It can be used in conjunction with Union Special Adjusting Manual IN9409.

It is the desire of Union Special that each machine run at its optimum performance. Parts listed in this manual are designed specifically for your machine and are manufactured with utmost precision to assure long lasting service.

This manual has been comprised on the basis of available information. Changes in design and/or improvements may incorporate a slight modification of configuration in illustrations or part numbers.

On the following pages are illustrations and terminology used in describing the parts used on 35800 Series machines.

SAFETY RULES



General Operating Directions

The sewing machines described in this instruction manual are prohibited from being put into service until it has been ascertained that the sewing units, in which these sewing machines will be built-in have conformed with the EC Council Directives (89/392/EEC, Annex II B).

1. Before putting the machines described in this manual into service, carefully read the instructions. The starting of each machine is only permitted after taking notice of the instructions and by qualified operators.

IMPORTANT! Before putting the machine into service, also read the safety rules and instruction from the motor supplier.

2. Observe the national safety rules valid for your country.
3. Each machine is only allowed to be used as foreseen. The foreseen use of the particular machine is described in paragraph "STYLES OF MACHINES" of this instruction manual. Another use, going beyond the description, is not as foreseen.
4. All safety devices must be in position when the machine is ready for work or in operation. Operation of the machine without the appertaining safety devices is prohibited.
5. The following safety devices are components of the sewing machines: Sewing guard, needle lever eyelet guard, needle bar guard, needle break protection shield and handwheel-belt guard.
6. When gauge parts are exchanged (e.g. needle, presser foot, needle plate, feed dog and bobbin) during threading, when the operator leaves the workplace, and during service work, the machine must be isolated form the mains by switching off the main switch or disconnecting the main plug. On mechanically operated clutch motors without a start inhibitor it is necessary to wait until the motor has stopped.

7. Wear safety glasses.
8. In case of machine conversions and changes all valid safety rules must be considered. Conversions and changes are made at your own risk.
9. Commissioning of the sewing head is prohibited until such time as the entire sewing unit is found to comply with EC regulations.
10. The warning hints in the instructions are marked with one of these two symbols:



Items require special attention



Danger of injury to operative or service staff

Be sure to observe and adhere to these indications and to the generally applicable regulations.

Special Operating Directions

11. For the following the machine has to be disconnected from the power supply by turning off the main switch or by pulling out the main plug:
 - 11.1 For threading needle(s), looper, spreader etc.
 - 11.2 For replacing sewing tools such as needle, presser foot, throat plate, looper, spreader, feed dog, needle guard, folder, fabric guide etc.
 - 11.3 When leaving the workplace and when the workplace is unattended.
 - 11.4 For maintenance work.
 - 11.5 When using clutch motors without actuation lock, wait until the motor is stopped totally.

General Maintenance Directions

12. Maintenance, repair and conversion work (see item 8) must be done only by trained technicians or special skilled personnel under consideration of the instructions.
13. Any work on the electrical equipment must be done by an electrician or under direction and supervision of special skilled personnel.

Special Maintenance Directions

14. Work on parts and equipment under electrical tension is not permitted. Permissible exceptions are described in the applicable sections of standard sheet DIN VDE 0105.
15. Before doing maintenance and repair work on the pneumatic equipment, the machine has to be disconnected from the compressed air supply. In case of existing residual air pressure after disconnecting from compressed air supply (e.g. pneumatic equipment with air tank), the pressure has to be removed by bleeding.

Exceptions are only allowed for adjusting work and function checks done by special skilled personnel.

Standards

17. The sewing machines described in this manual are built according to the following standards:
 - EN292-2 Safety of machinery-basic concepts, general principles for design.
 - IEC204-3-1/EN60204-3-1 Electrical equipment of industrial machines. Part 3: Particular requirements for sewing machines, units and systems.

CONTENTS

•IDENTIFICATION OF MACHINES	5
•CLASS DESCRIPTION	5
•STYLE OF MACHINES	5
•ILLUSTRATIONS	5
•ILLUSTRATIONS (CONT.)	6
•IDENTIFYING PARTS	6
•NEEDLES	6
•TERMS	6
EXPLODED VIEWS	
•MAIN FRAME, CAST-OFF PLATE, EYELETS, MISCELLANEOUS COVERS AND BUSHINGS	9
•MAIN FRAME, CAST-OFF PLATE, EYELETS, MISCELLANEOUS COVERS AND BUSHINGS (CONT.)	11
•CYLINDER COVERS AND BUSHINGS	13
•CYLINDER COVERS AND BUSHINGS (CONT.) (ALL GAUGES)	15
•NEEDLE BAR, NEEDLE HEAD, DETACHABLE HEAD AND MISCELLANEOUS COVERS	17
•MISCELLANEOUS OILING, NEEDLE LEVER, CRANKSHAFT AND MAIN SHAFT PARTS	19
•MISCELLANEOUS FEED PARTS, AND NEEDLE GUARDS	21
•MISCELLANEOUS FEED PARTS, LOOPER DRIVE PARTS AND LOOPERS	23
•UPPER ROLLER FEED, FOOT LIFTER AND THREAD TENSION PARTS	25
•UPPER ROLLER FEED, FOOT LIFTER AND THREAD TENSION PARTS (CONT.)	27
•PULLEY, CRANKSHAFT, CLUTCH AND CLUTCH DRIVING MECHANISM	29
•PULLEY, CRANKSHAFT, CLUTCH AND CLUTCH DRIVING MECHANISM (CONT.)	31
•PRESSER FOOT, THROAT PLATE, FEED DOGS	33
•THREAD STAND	35
•ACCESSORIES	36
•NOTES	37
•NOTES	38
•NOTES	39
•NOTES	40
•NOTES	41
•NUMERICAL INDEX OF PARTS	42
•NUMERICAL INDEX OF PARTS	43

IDENTIFICATION OF MACHINES

Each UNION SPECIAL machine is identified by a style number, which is stamped into the style plate affixed to the middle of the machine under the tension assembly.

The serial number is stamped in the casting at the right rear base of the machine.

CLASS DESCRIPTION

High Speed, Feed-Off-The-Arm High Throw Machines, Three Needle, Left Needle In Front. Light Weight Presser Bar Mechanism, Adjustable Looper Avoid, Space in Front of Needles 8" (203.2 mm), Single Disc Looper Thread Take-Up, Automatic Enclosed Type Oiling System and Filter Type Oil Pump, Visual Sight Oil Action and Supply Gauges, .558" wide roller.

STYLE OF MACHINES

- 35800DQW** **DOUBLE LAP SEAM.** Three needle high capacity, plain feed upper driven, roller feed (wide roller). -Typical Application- For in and out seams on medium weight denim garments. Seam Specification 401 LSc-3. Standard gauge Numbers 8, (1/8") (3.2mm) and 9, (9/64") (3.6mm). Recommended needle 130GS, size 125/049. Maximum recommended speed 4500 R.P.M.. .040 step parts.
- 35800DRW** **DOUBLE LAP SEAM.** Three needle, high capacity, plain feed, upper driven, roller feed (wide roller). Feeds have higher teeth on front of feeds. - Typical Application- For seat seaming, in and out seams on medium to heavy weight denim garments. Seam Specifications 401LSc-3. Standard gauge Numbers 8, (1/8") (3.2mm) and 9, (9/64") (3.6mm). Recommended needle 130GS, size 140/054. Maximum recommended speed 4500 R.P.M.. .094 step parts.
- 35800DRWL** **DOUBLE LAP SEAM.** *Same as 35800DRW without the folder.* Three needle, high capacity plain feed upper driven, roller feed (wide roller). Feeds have higher teeth on front of feeds. - Typical Application- For seat seaming, in and out seams on medium to heavy weight denim garments. Seam Specifications or 401 LSc-3. Standard gauge Numbers 8, (1/8") (3.2mm) and 9, (9/64") (3.6mm). Recommended needle 130GS, size 140/054. Recommended speed 4500 R.P.M.. .094 step parts.

ILLUSTRATIONS

This manual has been arranged to simplify ordering repair parts. Exploded views of various sections of the mechanism are shown so that the parts may be seen in their actual position in the machine. On the page opposite the illustration will be found a listing of the parts with their part numbers, description and the number of pieces required in the particular view being shown.

Numbers in the first column are reference numbers only, and merely indicate the position of the part in the illustration. The reference number should never be used in ordering parts. Always use the part number listed in the second column.

Component parts of sub-assemblies which can be furnished for repairs are indicated by indenting their descriptions under the description of the main sub-assembly. As an example refer to the following text.

9.	29126 EC	Upper Looper Drive Shaft Assembly	1
10.	22503 F	Screw	1
11.	39543 E	Cam Follower Locking Clamp	1

ILLUSTRATIONS (CONT.)

It will be noted in the previous example that the cam follower, bushing and cam guide and the upper looper drive shaft are not listed. The reason is that replacement of these parts individually is not recommended, so the complete upper looper drive shaft assembly should be ordered.

When a part is common to all machines covered in this manual, no specific usage will be mentioned in the description. However, when the parts for the various machines are not the same, the specific usage will be mentioned in the description and, if necessary, the difference will be shown in the illustration.

A numerical index of all the parts shown in this manual is located at the back. This will facilitate locating the illustration and description when only a part number is known.

IDENTIFYING PARTS

Where the construction permits, each part is stamped with its part number. On some of the smaller parts and on those where construction does not permit, an identification letter is stamped in to distinguish the part from similar ones.

PLEASE NOTE: Part numbers represent the same part, regardless of which manual they appear. On all orders please include part number, name and style of machine for which the part was ordered.

NEEDLES

Each needle has both a type and size number. The type number denotes the kind of shank, point, length, groove, finish and other details. The size number, stamped on the needle shank, denotes the largest diameter of the blade measured between the shank and the eye. Collectively, the type number and size number represent the complete symbol which is given on the label of all needles packed and sold by Union Special.

TYPE

DESCRIPTION

130 GS	Short, double groove, struck groove, ball eye, spotted, government point, chromium plated- Sizes available 080/032, 090/036, 100/040, 110/044, 125/049, 140/054, 150/060.
--------	---

To have needles promptly and accurately filled, an empty package, a needle sample, or the type and size number should be forwarded. Use the description on the label. A complete order should read as follows: "100 needles, type 130 GS, size 125/049".

TERMS

Prices are net cash and subject to change without notice. All shipments are forwarded F.O.B. shipping point. A charge is made to cover postage and insurance.

An exploded view diagram of a mechanical assembly, likely a multi-cylinder engine. The diagram shows various components such as cylinders, pistons, valves, and a crankshaft, arranged in their relative positions as they would be assembled. The drawing is a technical line drawing with a stippled or dotted background.

EXPLODED VIEWS ...

A267-94

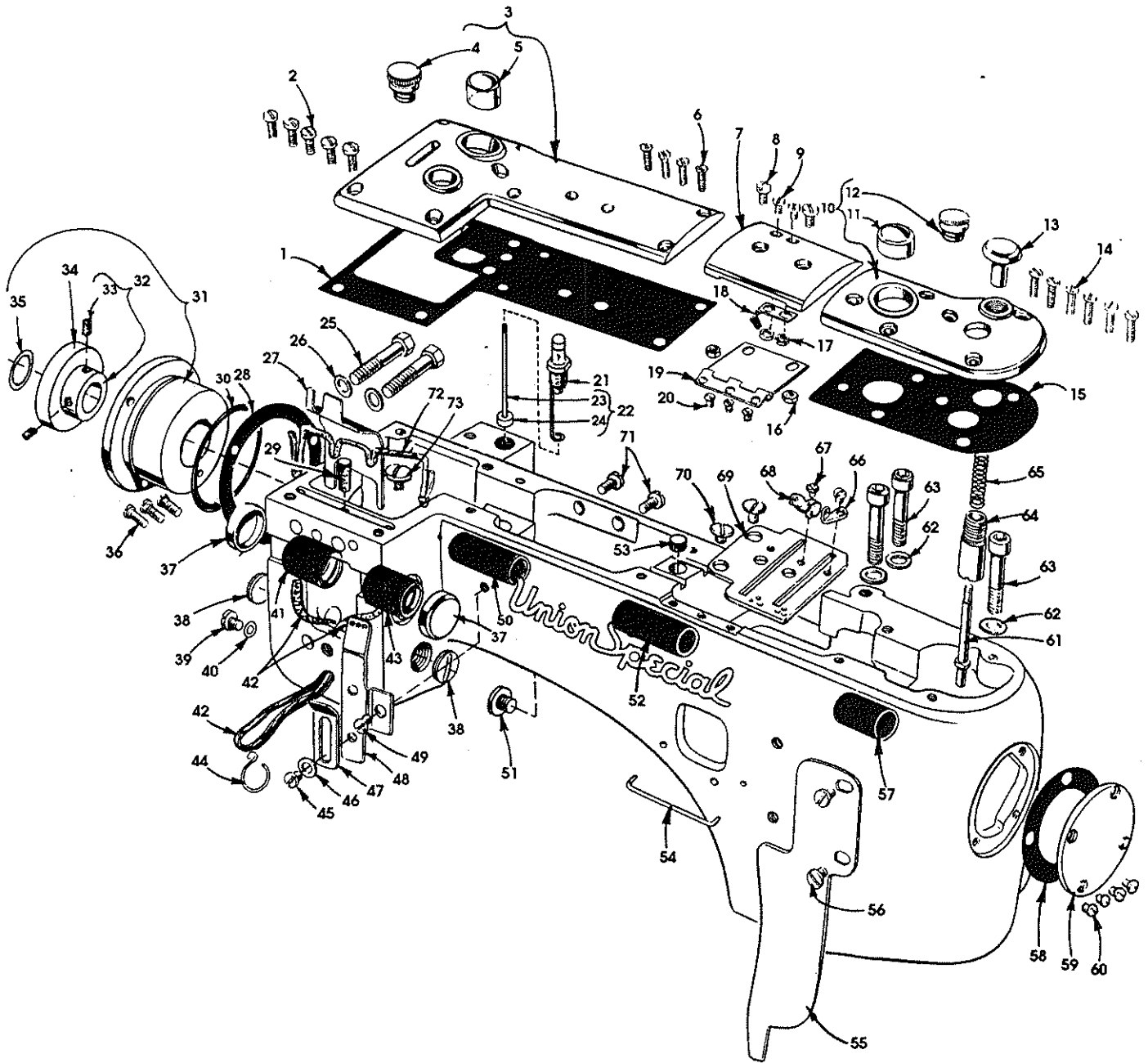

P180-94

MAIN FRAME, CAST-OFF PLATE, EYELETS, MISCELLANEOUS COVERS AND BUSHINGS

Ref. No.	Part No.	Description	Amt. Req.
1.	35888 P	Gasket	1
2.	93	Screw	5
3.	35888 NR	Crank Chamber Cover	1
4.	18-1426	Screw	1
5.	50-537 BLK	Oil Sight Gauge	1
6.	22516 A	Screw	4
7.	35887 X	Top Cover, middle	1
8.	93 A	Screw	2
9.	90	Screw	2
10.	35887 AE	Top Cover, front	1
11.	50-537 BLK	Oil Sight Gauge	1
12.	18-1426	Screw	1
13.	35853 Z	Looper Throw-Out Plunger Knob	1
14.	22516 A	Screw	6
15.	35887 AD	Gasket	1
16.	12934 A	Nut	2
17.	41071 G	Nut	2
18.	35887 M	Spring, top cover	1
19.	35887 R	Middle Top Cover Hinge	1
20.	22564 B	Screw	3
21.	36293 B	Oil Sight Gauge	1
22.	36293 F	Oil Sight Gauge Indicator Assembly	1
23.	36293 E	Oil Sight Indicator	1
24.	39593 C	Oil Gauge Float	1
25.	22759 A	Screw	2
26.	6042 A	Washer	2
27.	35889 H	Oil Shield	1
28.	56390 E	Gasket	1
29.	C 067 E	Cork	1
30.	660-1014	"O" Ring	1
31.	35890 M	Bearing Housing Assembly	1
32.	35890 L	Shaft Coupling	1
33.	22894 F	Screw	2
34.	660-1016	Bearing	1
35.	660-206	"O" Ring	1
36.	22569 B	Screw	3
37.	35761 D	Bushing Cap, plastic	2
38.	22539 T	Plug Screw	2
39.	22733 B	Oil Drain Screw	1
40.	660-935	"O" Ring	1
41.	35760 E	Needle Lever Shaft Bushing, rear	1
42.	CL 21	Oil Wick	1
43.	35760 D	Needle Lever Shaft Bushing, front	1
44.	35897 AW	Oil Wicking Hook, upper	1
45.	22570	Screw	1
46.	8372 A	Washer	1
47.	35871 A	Needle Thread Eyelet, three holes	1
48.	35871 B	Needle Thread Eyelet, three holes	1
49.	22570 A	Screw	1
50. thru 73. See following page			

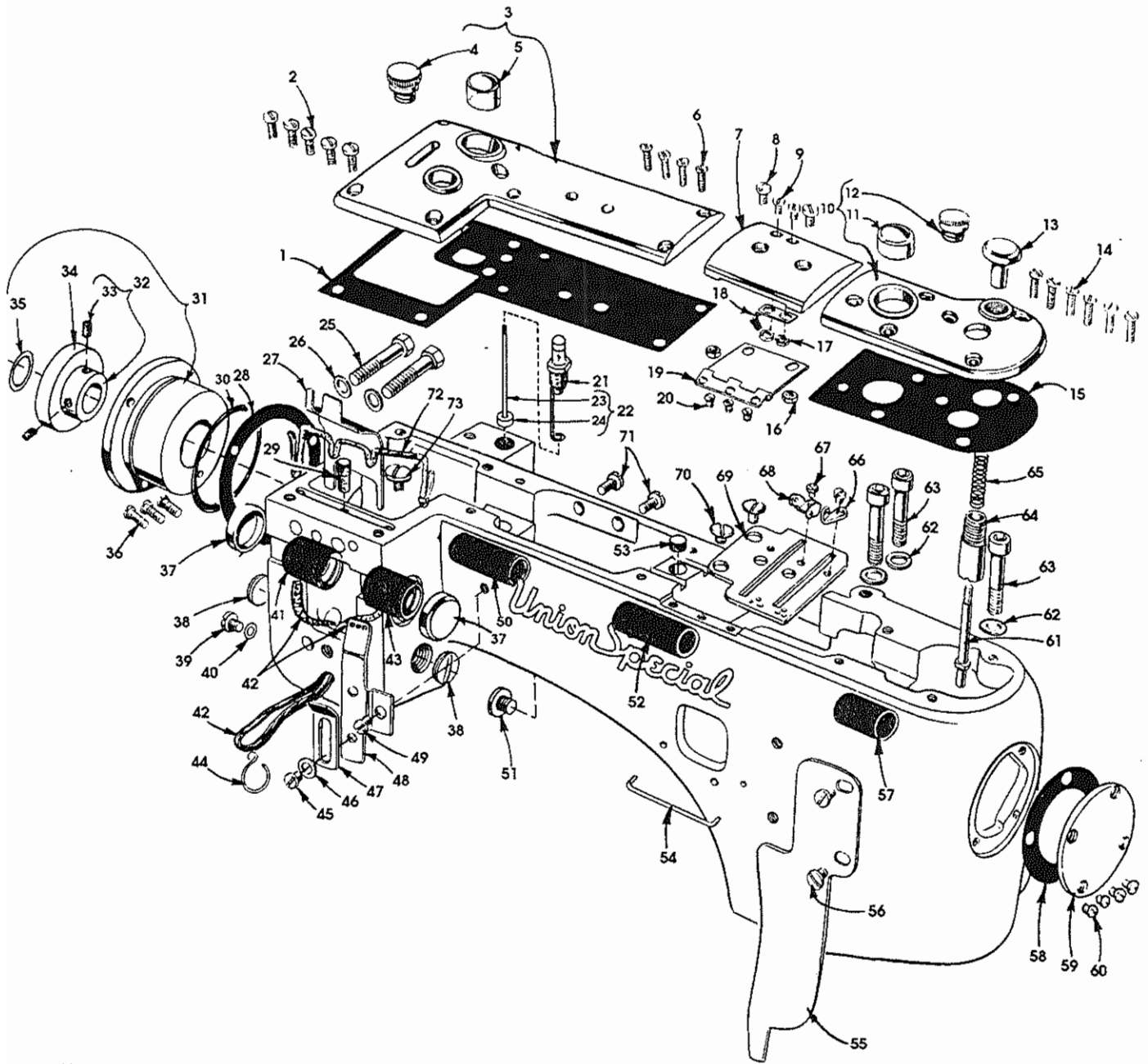

P180-94

MAIN FRAME, CAST-OFF PLATE, EYELETS, MISCELLANEOUS COVERS AND BUSHINGS (CONT.)

Ref. No.	Part No.	Description	Amt. Req.
	1. thru 49. See preceding page		
50.	35890 E	Crankshaft Bushing, front	1
51.	22733 B	Plug Screw	1
52.	35890 D	Main Shaft Bushing, rear	1
53.	50-539 BLK	Plug	1
54.	35781 D	Looper Thread Guide Wire	1
55.	35856 AA	Looper Thread Shield	1
56.	22829	Screw	2
57.	36290 B	Main Shaft Bushing, front	1
58.	35887 V	Gasket	1
59.	35887 Z	Main Frame End Cover	1
60.	22564 B	Screw	4
61.	35853 W	Looper Throw-Out Plunger	1
62.	35876 U	Washer	3
63.	22653 E-20	Screw	3
64.	35853 AA	Looper Throw-Out Plunger Bushing	1
65.	35853 Y	Looper Throw-Out Plunger Spring	1
66.	35772 T	Cast-Off Plate Eyelet, front	1
67.	28	Screw	2
68.	35772 S	Cast-Off Plate Eyelet, rear	1
69.	35704 C	Cast-Off Plate	1
70.	22730	Screw	2
71.	93	Screw, for rotary pump housing	2
72.	CL 21	Oil Wick	1
73.	22711	Screw, for oil wick	1

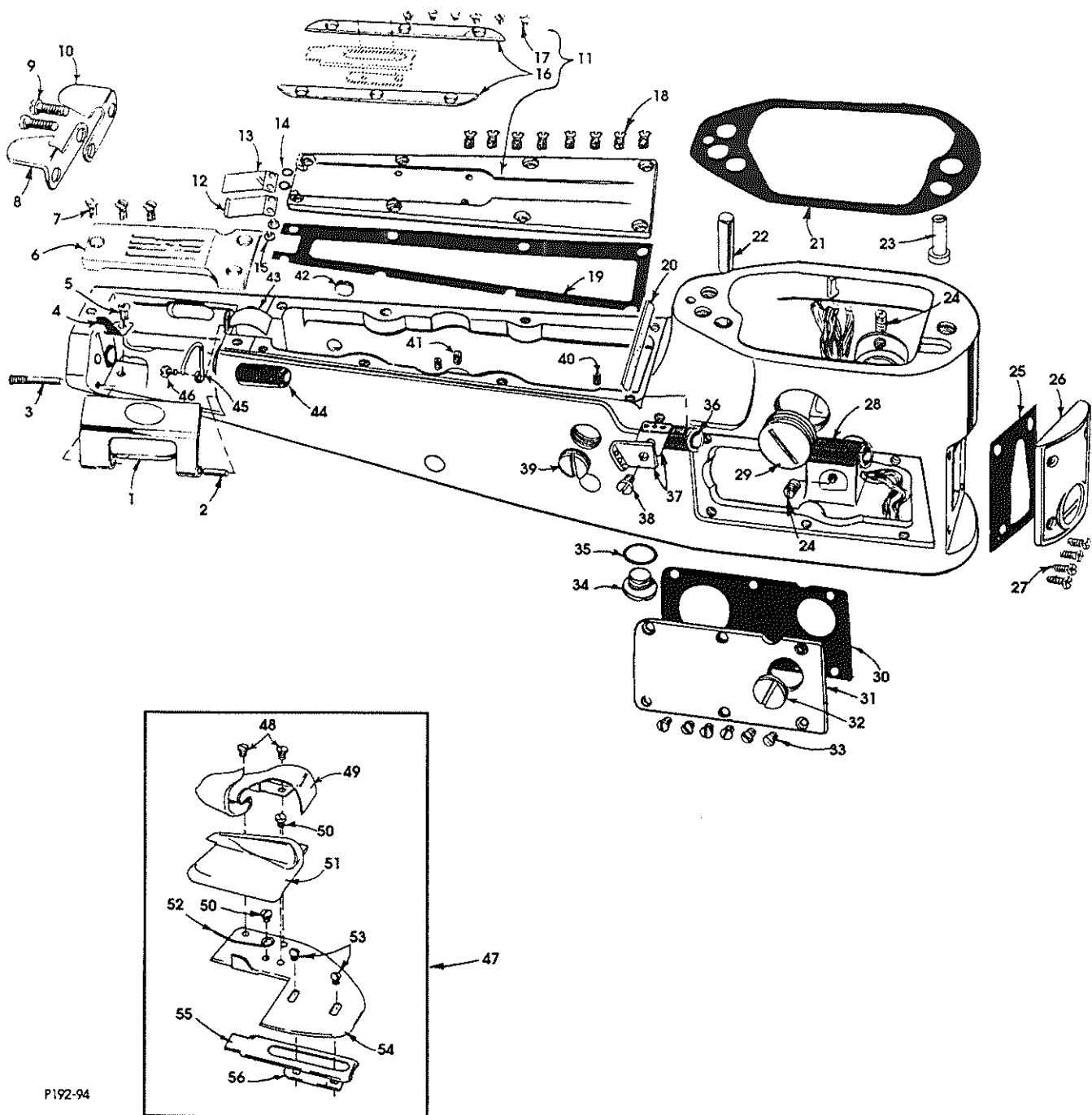

P192-94

CYLINDER COVERS AND BUSHINGS

Ref. No.	Part No.	Description	Amt. Req.
1.	35883 H	Cylinder Hinged Cover	1
2.	35883 G	Pin	1
3.	35883 F	Screw Pin	1
4.	35883 E	Spring	1
5.	90	Screw	1
6.	-----	Throat Plate (see to page 33)	1
7.	22524	Screw, for all throat plates	3
8.	35796 B	Chain Cutter Blade, upper	1
9.	22747	Screw	2
10.	35796 C	Chain Cutter Blade, lower	1
11.	35883 A	Cylinder Cover	1
12.	35884 E	Cylinder Lint Shield, upper	1
13.	35884 F	Cylinder Lint Shield Spring	1
14.	27-435 BLK	Washer	2
15.	22798	Screw	2
16.	35883 J	Cylinder Cover Adjustable Gib	2
17.	22561 A	Screw	6
18.	22526 B	Screw	8
19.	35883 M	Gasket	1
20.	35883 V	Gasket	1
21.	36284	Gasket	1
22.	667 D-16	Dowel Pin, straight	1
23.	664 F-24	Dowel Pin, tapered	1
24.	531	Screw	2
25.	35884 D	Gasket	1
26.	35884 H	Cylinder Cover and Oil Gauge	1
27.	J 87 J	Screw	4

28. thru 56. See following page

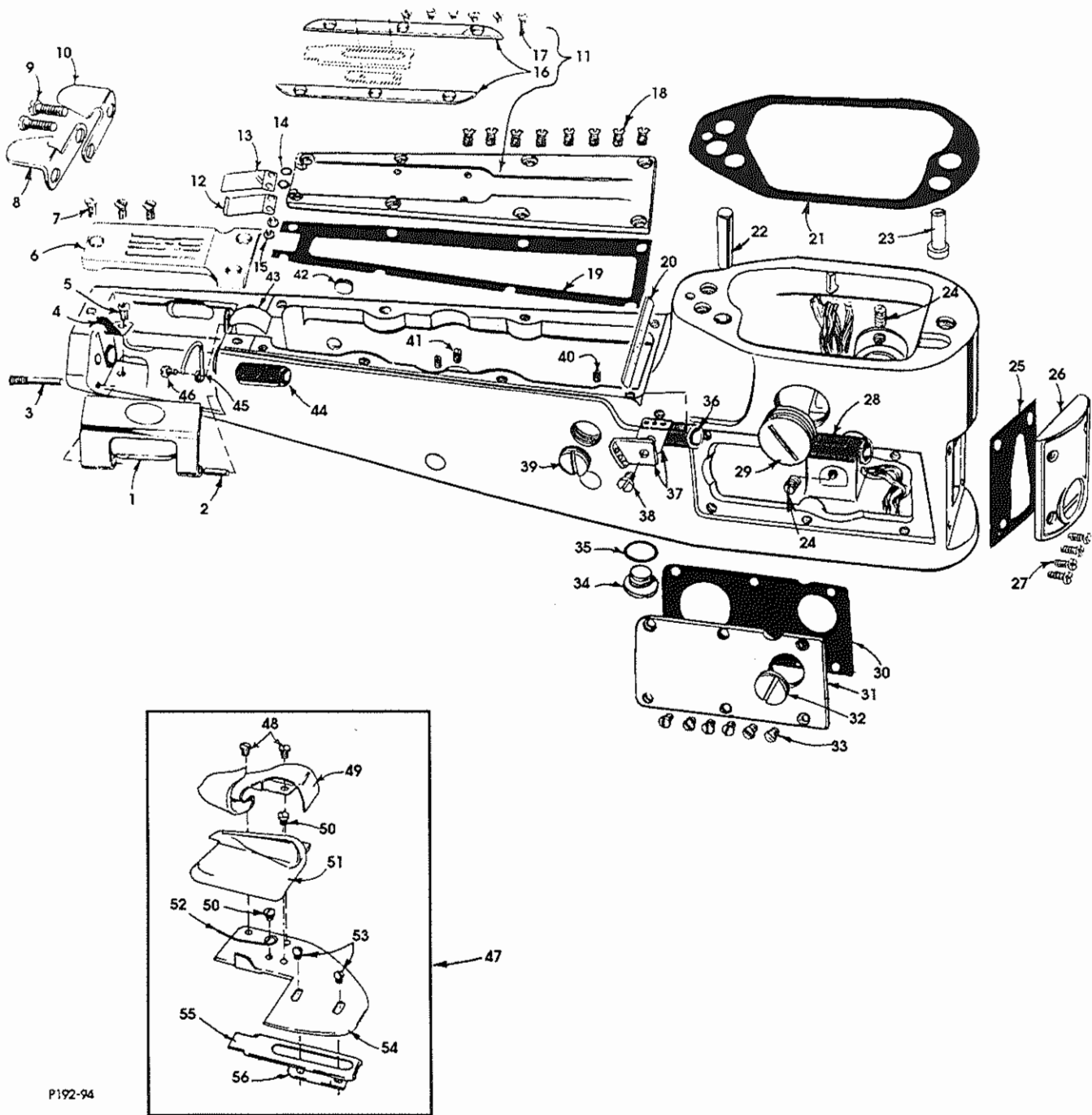

P192-94

**CYLINDER COVERS AND BUSHINGS (CONT.)
(ALL GAUGES)**

Ref. No.	Part No.	Description	Amt. Req.
1. thru 27. See preceding page			
28.	35850 C	Looper Shaft Bushing, front	1
29.	22539 D	Plug Screw	1
30.	35886 B	Gasket	1
31.	35886 C	Cylinder Side Cover	1
32.	22539 C	Plug Screw	1
33.	22564 B	Screw	6
34.	22733 A	Oil Drain Plug Screw	1
35.	35897 AX	Gasket	1
36.	35850 B	Looper Shaft Bushing, middle	1
37.	35856 Y	Looper Thread Eyelet	2
38.	22849 A	Screw	1
39.	22539 H	Plug Screw	1
40.	88	Screw, for feed rocker shaft	1
41.	531	Screw, for feed lifter lever shaft	2
42.	22571 A	Plug Screw	1
43.	35884 P	Lower Lint Shield	1
44.	35850 D	Looper Shaft Bushing, rear	1
45.	36256 B	Looper Thread Guide Wire	1
46.	22849	Screw	1
47.	23420 CC 18-1/8	Folder Assembly, for all Styles except 35800DRWL	1
48.	22513	Screw	2
49.	23421 CC 18-1/8	Upper Scroll	1
50.	22760 A	Screw	2
51.	23422 CC18-1/8	Lower Scroll	1
52.	23424 S	Spring	1
53.	22849 A	Screw	2
54.	642-423 BLK	Base	1
55.	23423 V	Sliding Base	1
56.	23423 W	Clamp, for sliding base	1

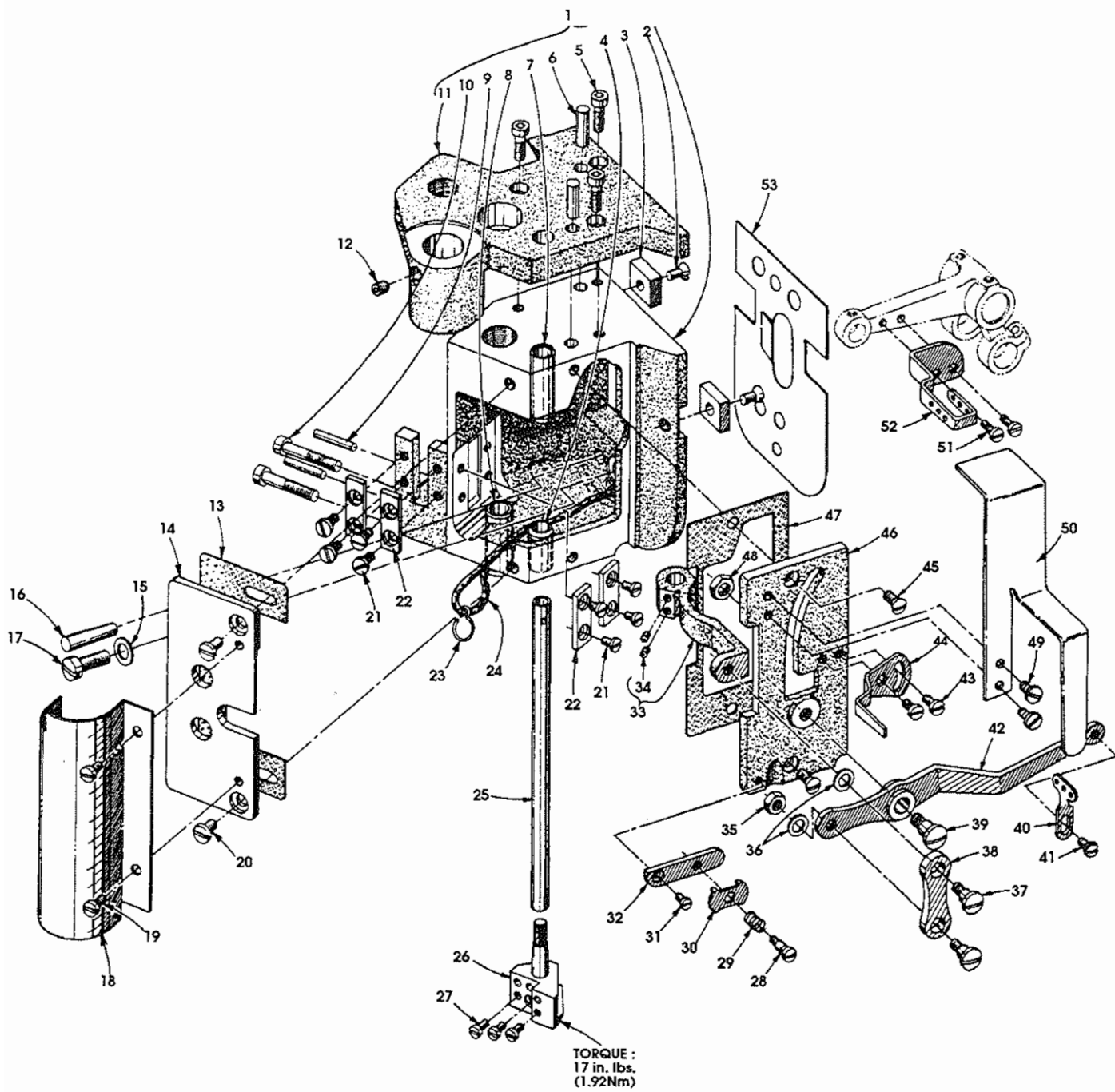

P178-94

NEEDLE BAR, NEEDLE HEAD, DETACHABLE HEAD AND MISCELLANEOUS COVERS

Ref. No.	Part No.	Description	Amt. Req.
1.	35829 AC	Detachable Head	1
2.	22524	Screw	2
3.	35767	Sewing Head Key	2
4.	35859 L	Needle Bar Bushing, lower	1
5.	22653 B-8	Screw	3
6.	667 C-12	Dowel Pin	2
7.	35859 K	Needle Bar Bushing, upper	1
8.	35831 G	Presser Bar Bushing, lower	1
9.	667 B-20	Dowel Pin	2
10.	22653 B-16	Screw	2
11.	35876 AA	Puller Clutch Bracket	1
12.	22894 C	Screw	1
13.	35889 AA	Gasket	1
14.	35889 Y	Detachable Head Cover	1
15.	6042 A	Washer	1
16.	664 F-16	Dowel Pin, tapered	1
17.	318	Screw	1
18.	35889 Z	Detachable Head Cover	1
19.	22564 B	Screw	2
20.	22829	Screw	2
21.	22513	Screw	8
22.	35731 A	Presser Bar Guide Plate	4
23.	35897 AW	Oil Wicking Hook	1
24.	CL 21	Oil Wick	1
25.	35817 E	Needle Bar, marked "DY"	1
26.	35818 BY-8	Needle Bar Head, marked "V-8", for all 8 gauge styles	1
-	35818 BY-9	Needle Bar Head, marked "V-9", for all 9 gauge styles	1
27.	605	Screw	3
28.	57 WD	Screw	1
29.	15438 C	Needle Thread Nipper Spring	1
30.	57 WB	Needle Thread Nipper Spring Plate	1
31.	605	Screw	1
32.	43296	Needle Thread Nipper Base	1
33.	35869 L	Thread Controller Arm	1
34.	89	Screw	2
35.	12934 A	Nut	1
36.	69 H	Washer	2
37.	22758 E	Screw	2
38.	35869 D	Control Lever Connection Link	1
39.	22557 A	Screw	1
40.	35869 K	Needle Thread Lever Control Eyelet	1
41.	25 B	Screw	1
42.	35869 C	Needle Thread Control Lever	1
43.	22768	Screw	2
44.	35870	Needle Thread Take-up	1
45.	22524	Screw	2
46.	35889 X	Detachable Head Cover, front	1
47.	35889 B	Gasket	1
48.	12982	Nut	1
49.	22768	Screw	2
50.	35854	Needle Bar Guard	1
51.	77	Screw	2
52.	35864 F	Needle Lever Thread Eyelet	1
53.	35889 G	Baffle Plate	1

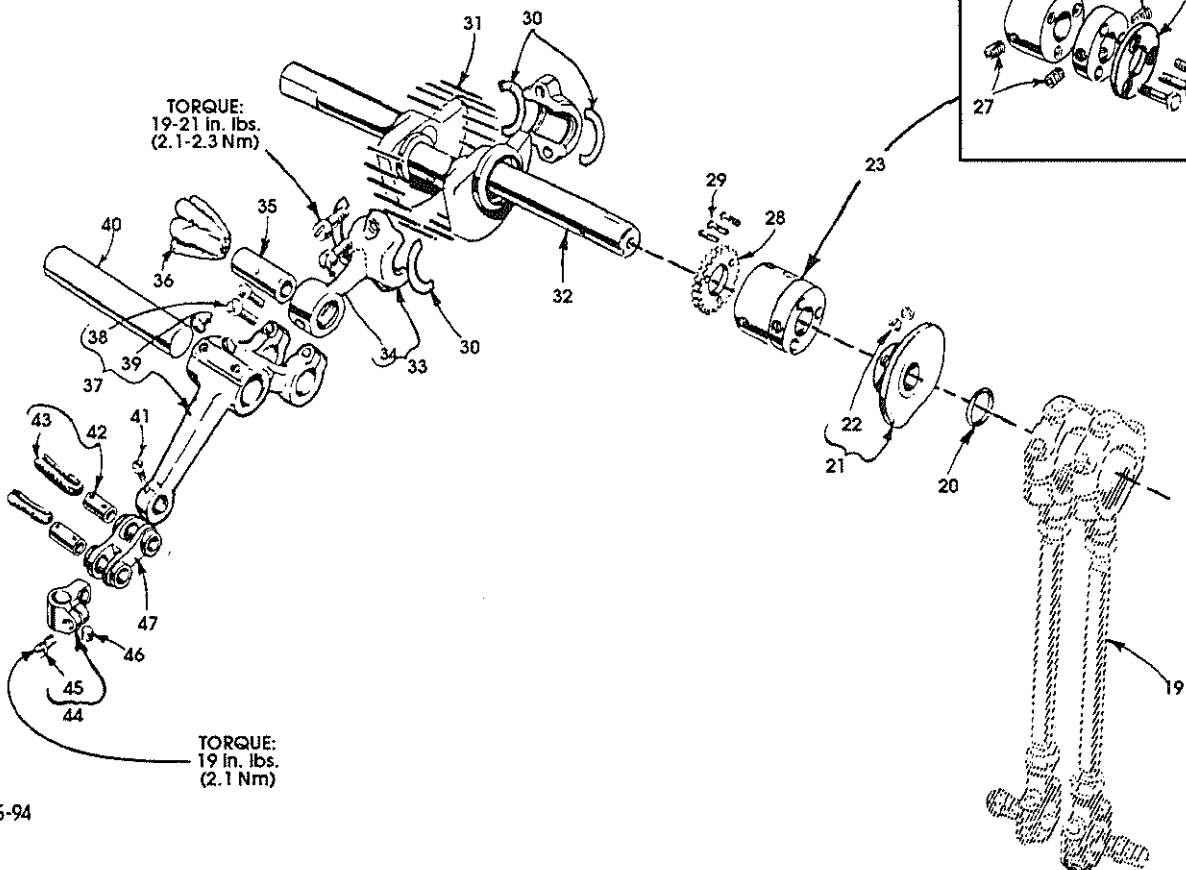
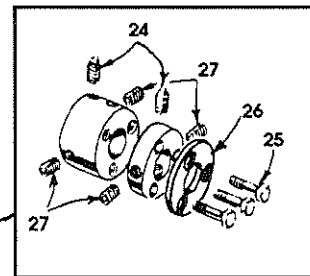
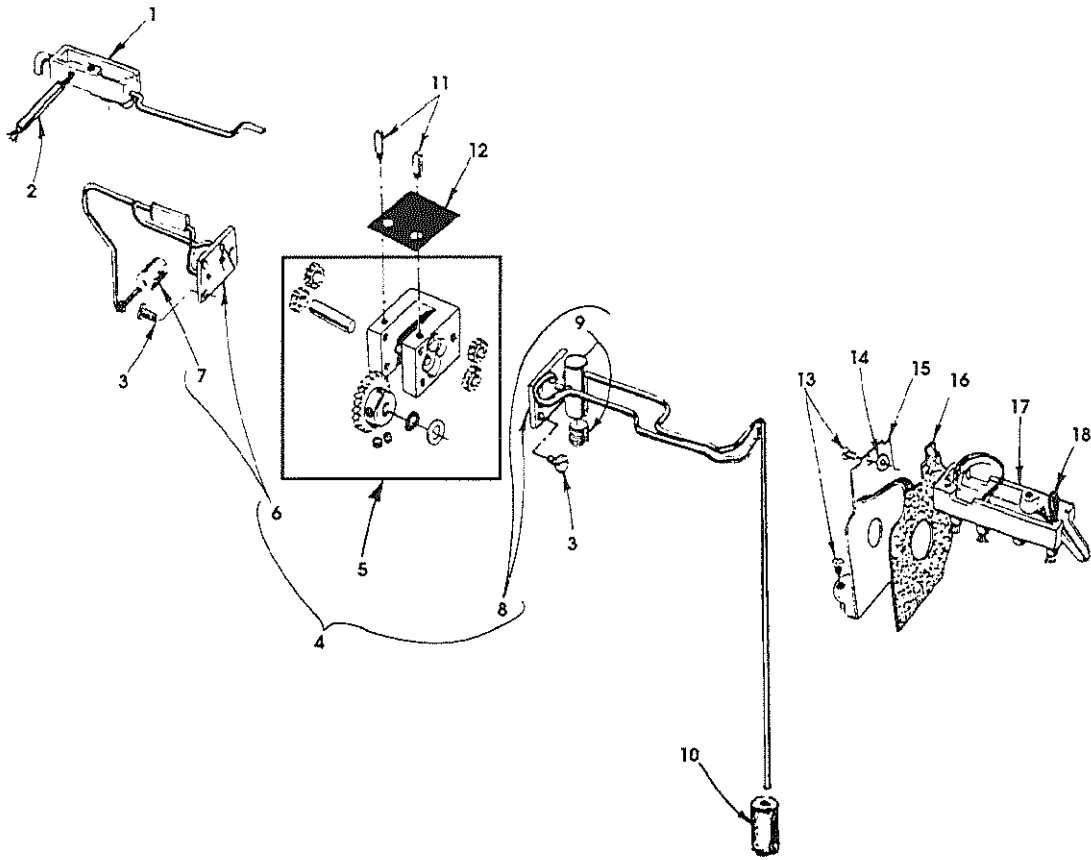

MISCELLANEOUS OILING, NEEDLE LEVER, CRANKSHAFT AND MAIN SHAFT PARTS

Ref. No.	Part No.	Description	Amt. Req.
1.	35894 V	Oil Reservoir, back	1
2.	35897 BU	Oil Reservoir Outlet Tube	1
3.	22585 A	Screw	6
4.	29472 AA	Oil Pump Assembly	1
5.	29472 AC	Pump Assembly	1
6.	35897 CC	Oil Pump Assembly Cover, rear, for oil pump assembly	1
7.	35897 BV	Intake Filter	1
8.	35897 BM	Oil Pump Housing Cover, front	1
9.	22571 B	Plug Scw	1
10.	35897 BV	Intake Filter	1
11.	21756 G	Vent Screw, for oil pump	2
12.	35897 BW	Gasket	1
13.	90	Screw	1
14.	80265	Spacer Washer	1
15.	36261 B	Take-up Shield	1
16.	35861 D	Gasket	1
17.	35894 K	Oil Reservoir, front	1
18.	WO 3	Oil Wick	1
19.	29478 BD	Connecting Rod Assembly (see page 21, ref. no. 23)	1
20.	660-202	Oil Seal Ring.....	1
21.	35723 C	Looper Thread Take-Up	1
22.	22580 D	Screw	2
23.	35895 W	Main Shaft and Crankshaft Coupling	1
24.	22894 K	Spot Screw	2
25.	22519 F	Screw	3
26.	35895 Z	Washer Plate	1
27.	22894 J	Set Screw	4
28.	35897 BY	Oil Pump Driving Gear	1
29.	22797	Screw	3
30.	35763 G	Needle Bearing Retainer	4
31.	35763 F	Needle Bearing	28
32.	35822 W	Crankshaft	1
33.	35862	Needle Lever Connecting Rod	1
34.	22587 B	Screw	2
35.	35763	Needle Lever Connecting Rod Pin	1
36.	WO 3	Oil Wick	1
37.	35815 A	Needle Lever	1
38.	22729	Screw	2
39.	22596 B	Screw	2
40.	35761	Needle Lever Shaft	1
41.	77	Screw	1
42.	51054	Link Pin	2
43.	666-149	Oil Wick	2
44.	51254 J	Needle Bar Connection	1
45.	22562 A	Screw	1
46.	22564	Screw	1
47.	56354 A	Needle Lever Link	1

Ref. No.'s 25 & 27
 TORQUE:
 19-21 in. lbs.
 (2.1-2.3 Nm)

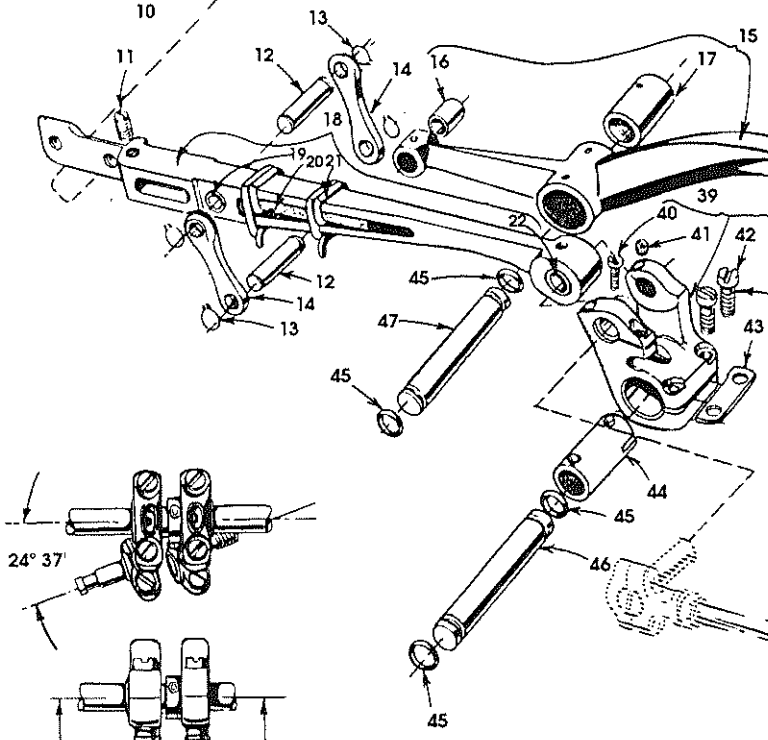
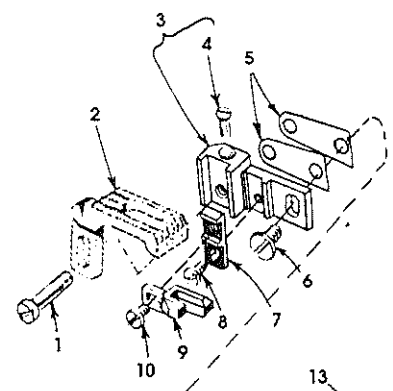

Ref. No.'s 33 & 35
 TORQUE:
 19-21 in. lbs.
 (2.1-2.3 Nm)

TORQUE:
 25 in. lbs.
 (2.8 Nm)

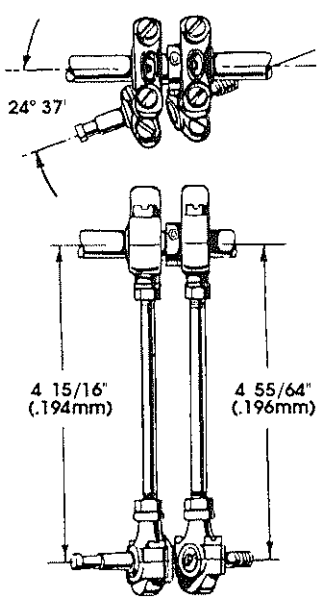

P189-94

MISCELLANEOUS FEED PARTS, AND NEEDLE GUARDS

Ref. No.	Part No.	Description	Amt. Req.
1.	22874 C	Screw, for all feed dogs	1
2.	-----	Feed Dog (see page 33)	1
3.	35834 U	Feed Dog Holder	1
4.	538	Screw, for adjusting feed dog height	1
5.	35834 V-3	Feed Dog Holder Shim	2
6.	376	Screw	1
7.	35835 B	Needle Guard Holder	1
8.	22768	Screw	1
9.	35825 AC	Needle Guard	1
10.	87 U	Screw, for needle guard	1
11.	22580 A	Feed Dog Support Screw	1
12.	35844 E	Link Pin	2
13.	660-199	Retaining Ring	4
14.	35844 D	Link, right and left (pair)	1
15.	35844	Feed Lifter Lever	1
16.	35844 C	Bushing	1
17.	35736 A	Bushing	1
18.	35834 R	Feed Bar	1
19.	35834 N	Bushing	1
20.	666-47	Oil Wicking	1
21.	660-548	Wire Spring Clip	2
22.	35834 G	Bushing	1
23.	29478 BD	Connecting Rod Assembly	1
24.	29101 G	Avoid Eccentric	1
25.	22578 E	Screw	4
26.	88	Screw	1
27.	22764	Screw	1
28.	269	Nut, left thread	2
29.	35847 E	Feed Lift Eccentric Connecting Rod	1
30.	43246	Feed Rocker and Looper Avoid Eccentric Connecting Rod	1
31.	18	Nut, right thread	2
32.	35846	Ball Joint	1
33.	22729 C	Screw	2
34.	35841 B	Ball Joint	1
35.	22729 C	Screw	2
36.	41355 U-4	Shim, .004 inch (0.10 mm) thick	as required
-	41355 U-5	Shim, .005 inch (0.13 mm) thick	as required
-	41355 U-6	Shim, .006 inch (0.15 mm) thick	as required
-	41355 U-7	Shim, .007 inch (0.18 mm) thick	as required
-	41355 U-8	Shim, .008 inch (0.20 mm) thick	as required
-	41355 U-9	Shim, .009 inch (0.23 mm) thick	as required
37.	35746 A	Washer	1
38.	258	Nut	1
39.	35836	Feed Rocker	1
40.	22747	Screw	1
41.	22743	Screw	1
42.	22572	Screw	2
43.	35736 B	Feed Rocker Bushing Key	1
44.	35736 A	Feed Rocker Bushing	1
45.	660-221	"O" Ring	4
46.	35843 B	Feed Rocker Shaft	1
47.	35845 D	Feed Lift Lever Shaft	1

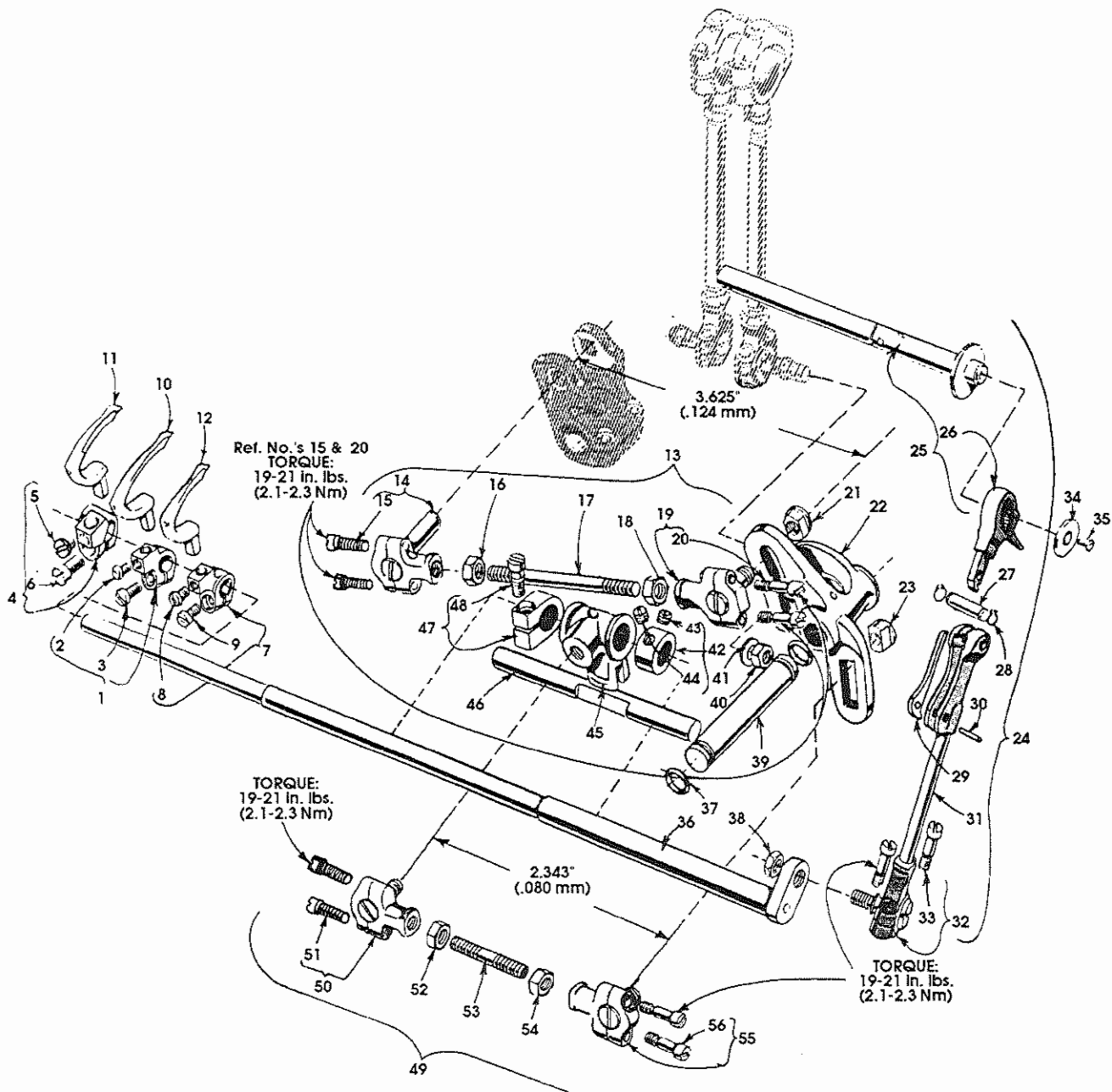

MISCELLANEOUS FEED PARTS, LOOPER DRIVE PARTS AND LOOPERS

Ref. No.	Part No.	Description	Amt. Req.
1.	35848 D	Looper Holder, for middle looper, marked "C"	1
2.	22562 A	Screw	1
3.	22564	Screw	1
4.	35848 E	Looper Holder, for right looper, marked "D"	1
5.	22562 A	Screw	1
6.	22564	Screw	1
7.	35848 B	Looper Holder, for left looper, marked "A"	1
8.	22562 A	Screw	1
9.	22564	Screw	1
10.	35809 AY	Looper, middle, marked "AV"	1
11.	35809 BY	Looper, left, marked "AY"	1
12.	35808 AY	Looper, right, marked "AU"	1
13.	29478 AH	Feed Rocker Connecting Rod Assembly	1
14.	35837 A	Ball Joint	1
15.	22729 C	Screw	2
16.	18	Nut, right thread	1
17.	39141	Connecting Rod	1
18.	269	Nut, left thread	1
19.	35837 N	Ball Joint	1
20.	22729 C	Screw	2
21.	35866	Nut	1
22.	35842	Feed Rocker and Looper Avoid Lever	1
23.	35766 A	Nut	1
24.	29478 DZ	Looper Drive Connecting Rod Assembly	1
25.	35722 AF	Main Shaft Assembly	1
26.	35853 AJ	Looper Drive Connection	1
27.	35853 V-156	Hinge Pin	1
28.	660-310	Tru-Arc Ring	2
29.	56341 G	Locking Spring	1
30.	50-458 BLK	Pin	1
31.	35853 AK	Looper Drive Connecting Rod	1
32.	35853 AD	Ball Joint, looper shaft	1
33.	22729 D	Screw	2
34.	35895 V	Washer	1
35.	22526	Screw	1
36.	35842 H	Feed Rocker and Looper Lever Shaft	1
37.	660-220	Oil Seal Ring	2
38.	258 A	Nut	1
39.	35849 B	Looper Rocker Shaft	1
40.	258	Nut	1
41.	35746 A	Washer	1
42.	35751 F	Looper Shaft Collar	1
43.	88	Screw	1
44.	89	Screw	1
45.	35751	Looper Rocker Shaft Cross Head	1
46.	35751 B	Cross Head Guide Shaft	1
47.	35751 G	Thrust Collar	1
48.	22752 B	Screw	1
49.	29478 AJ	Connecting Rod Assembly	1
50.	35851 A	Ball Joint	1
51.	22729 C	Screw	2
52.	18	Nut, right thread	1
53.	35851 G	Connecting Rod	1
54.	269	Nut, left thread	1
55.	35851	Ball Joint	1
56.	22729 C	Screw	2

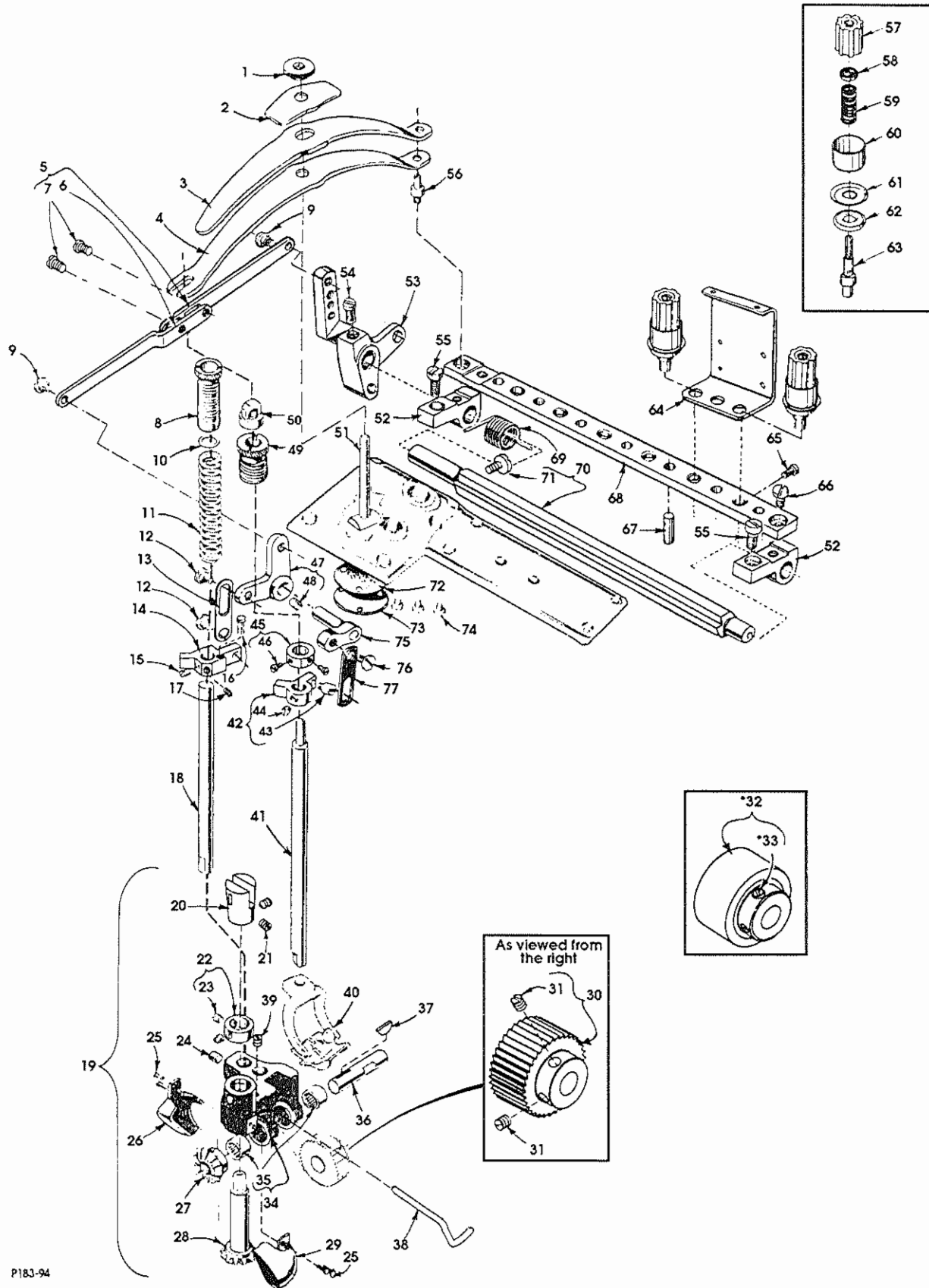

P183-94

UPPER ROLLER FEED, FOOT LIFTER AND THREAD TENSION PARTS

Ref. No.	Part No.	Description	Amt. Req.
1.	35733 B	Presser Regulating Nut	1
2.	35833 C	Presser Spring Plate	1
3.	35833 E	Presser Spring, upper	1
4.	35833 D	Presser Spring, lower	1
5.	36280 V	Lifter Lever Link Assembly	1
6.	36280 U	Lifter Lever Link	1
7.	22585 C	Screw	2
8.	35857 W	Roller Presser Spring Regulator	1
9.	86	Screw	2
10.	61256 G	Roller Presser Spring Washer	1
11.	35873 Z	Roller Presser Spring	1
12.	22758 C	Screw	2
13.	35880 K	Lifter Lever Bell Crank Link	1
14.	35873 AH	Presser Bar Connection Guide	1
15.	89	Screw	1
16.	22764	Screw	1
17.	22764 A	Screw	1
18.	35873 W	Roller Presser Bar	1
19.	29478 ED	Puller Assembly	1
20.	54274 C	Feed Roller Lower Connection	1
21.	22894 W	Screw	2
22.	14649	Drive Gear Collar	1
23.	88	Screw	2
24.	22894 C	Screw	1
25.	22738	Screw	4
26.	35875 AA	Gear Guard, front	1
27.	35875 X	Driven Miter Gear	1
28.	35875 Y	Drive Miter Gear	1
29.	35875 Z	Gear Guard, rear	1
30.	35826 X	Feed Roller	1
31.	22560 B	Screw	2
*32.	35826 DZ	Wide Rubber Roller	1
*33.	22560 B	Screw	2
34.	35873 AJ	Feed Roller Frame	1
35.	660-303	Needle Bearing	2
36.	35873 AK	Feed Roller Shaft	1
37.	35877 AA	Woodruff Key	1
38.	21237 ES	Air Blower Tube	1
39.	73 A	Screw	1
40.	-----	Presser Foot (see to page 33)	1
41.	35878 S	Presser Bar	1
42.	35831 C	Presser Bar Lifter and Guide	1
43.	402	Screw	1
44.	22560 B	Screw	1

45. thru 77. See following page

*Items can be purchased as an extra send charge.

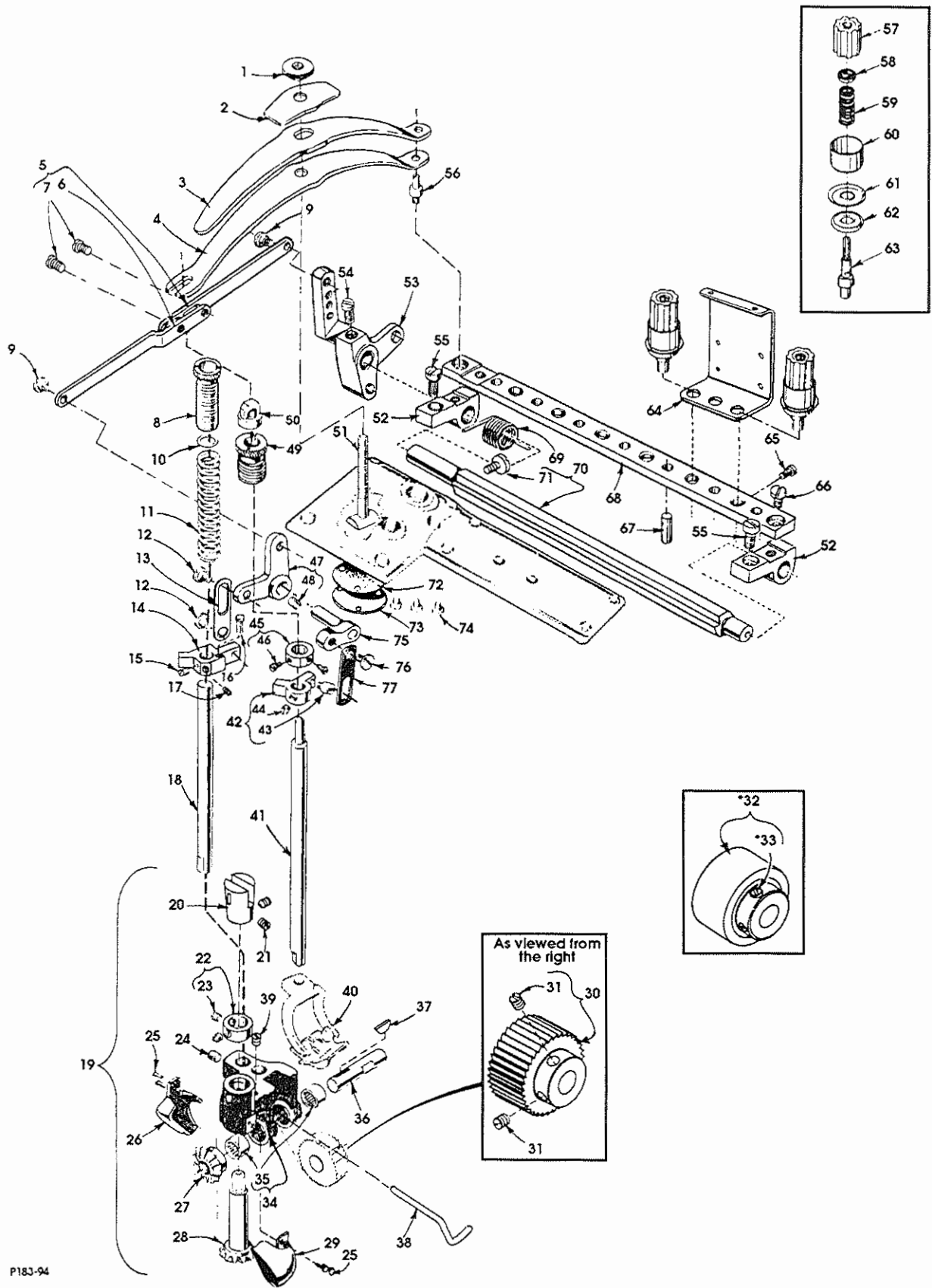

P183-94

UPPER ROLLER FEED, FOOT LIFTER AND THREAD TENSION PARTS (CONT.)

Ref. No.	Part No.	Description	Amt. Req.
	1. thru 44. See preceding page		
45.	52888 B	Collar	1
46.	22562	Screw	2
47.	35880 P	Lifter Lever Bell Crank	1
48.	22894 J	Screw	1
49.	35878 H	Presser Bar Bushing and Spring Regulator	1
50.	55287 L	Presser Spring Rest	1
51.	35878 F	Presser Spring Regulating Screw	1
52.	36292 M	Tension Plate Bracket	2
53.	36280 W	Lifter Lever	1
54.	22839 D	Screw	1
55.	136	Screw	2
56.	35833 F	Presser Spring Rest	1
57.	C 50092 S	Tension Nut	6
58.	39592 AK	Tension Post Ferrule	6
59.	51292 F-4	Looper Thread Tension Spring, for looper	3
-	110-3	Needle Thread Tension Spring, for needle	3
60.	56392 F	Shield, tension spring	6
61.	35792	Tension Disc, large	6
62.	109	Tension Disc, small	6
63.	36292 P	Tension Post	6
64.	36298 G	Tension Thread Eyelet	3
65.	22562 A	Screw	6
66.	94	Screw	1
67.	35792 T	Tension Disc Release Pin	7
68.	36298 F	Tension Support	1
69.	36292 K	Tension Release Shaft Spring	1
70.	36292 N	Tension Release Shaft	1
71.	22784 F	Screw	1
72.	35888 M	Gasket	1
73.	35888 L	Cover Plate	1
74.	98 A	Screw	3
75.	35880 N	Presser Bar Lifter Lever	1
76.	22758 C	Screw	1
77.	35880 L	Lifter Lever Connecting Link	1

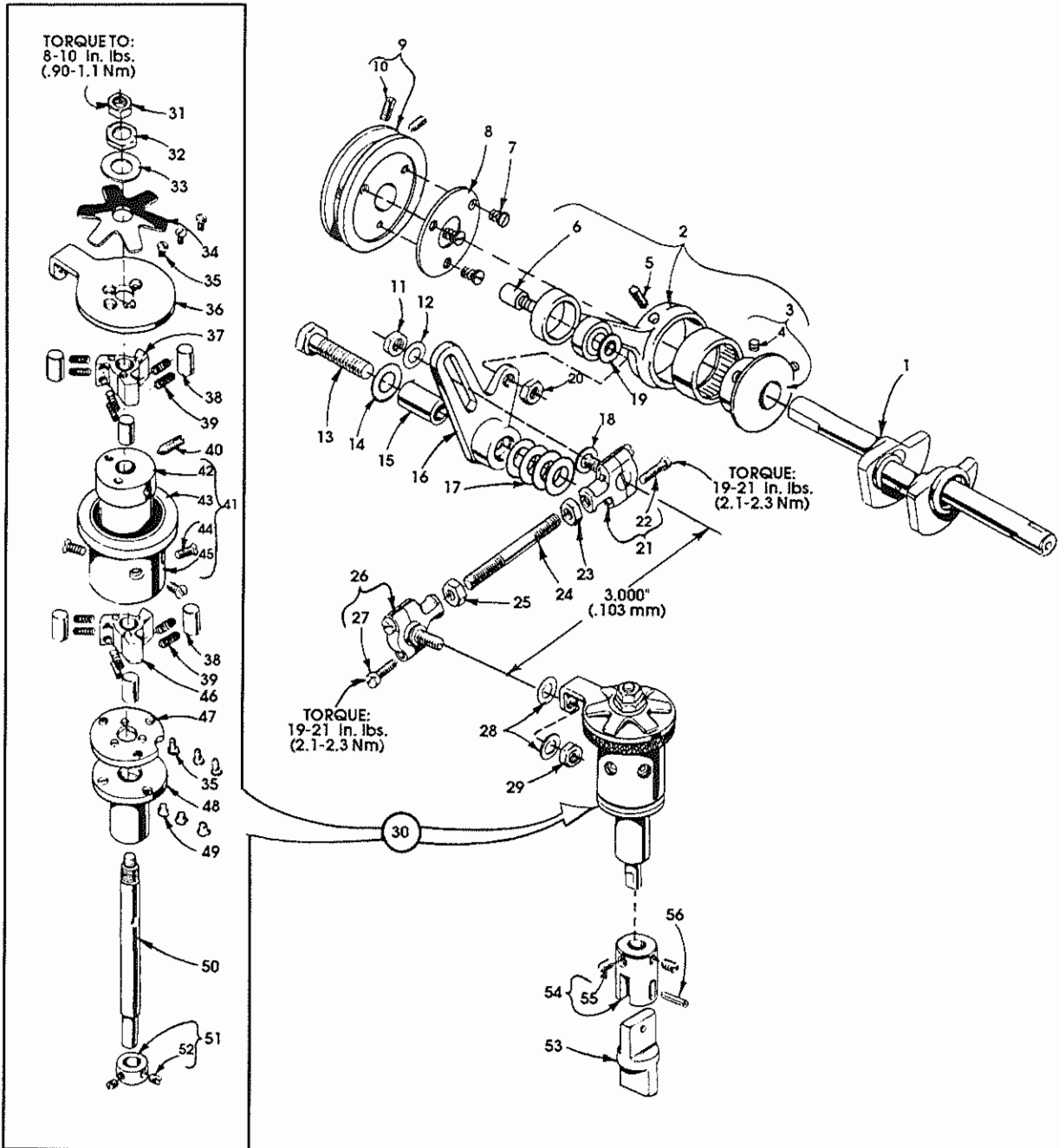

P197-94

PULLEY, CRANKSHAFT, CLUTCH AND CLUTCH DRIVING MECHANISM

Ref. No.	Part No.	Description	Amt. Req.
1.	35822 W	Crankshaft	1
2.	29480 ALY	Connecting Rod and Clutch Driving Eccentric Assembly	1
3.	35877 XA	Eccentric	1
4.	22894 C	Screw	2
5.	666-186	Oil Wick	1
6.	50342 V	Shoulder Screw	1
7.	22589	Screw	3
8.	35821 V	Washer	1
9.	35821 F	Pulley	1
10.	22894 E	Set Screw	2
11.	18	Nut	1
12.	20	Washer	1
13.	22644 K-80	Screw	1
14.	61351 C	Washer	1
15.	35877 N	Segment Lever Bushing	1
16.	35877 Z	Clutch Driving Segment Lever	1
17.	61351 C	Washer	4
18.	36 G	Washer	1
19.	6042 A	Washer	1
20.	258	Nut	1
21.	35876 V	Ball Joint Assembly, right	1
22.	22729 C	Screw	2
23.	269	Nut, for left hand thread	1
24.	4761	Roller Clutch Connecting Rod	1
25.	18	Nut, for right hand thread	1
26.	35876 W	Roller Clutch Ball Joint Assembly, left	1
27.	22729 C	Screw	2
28.	20	Washer	2
29.	18	Nut	1

30. thru 56. See following page

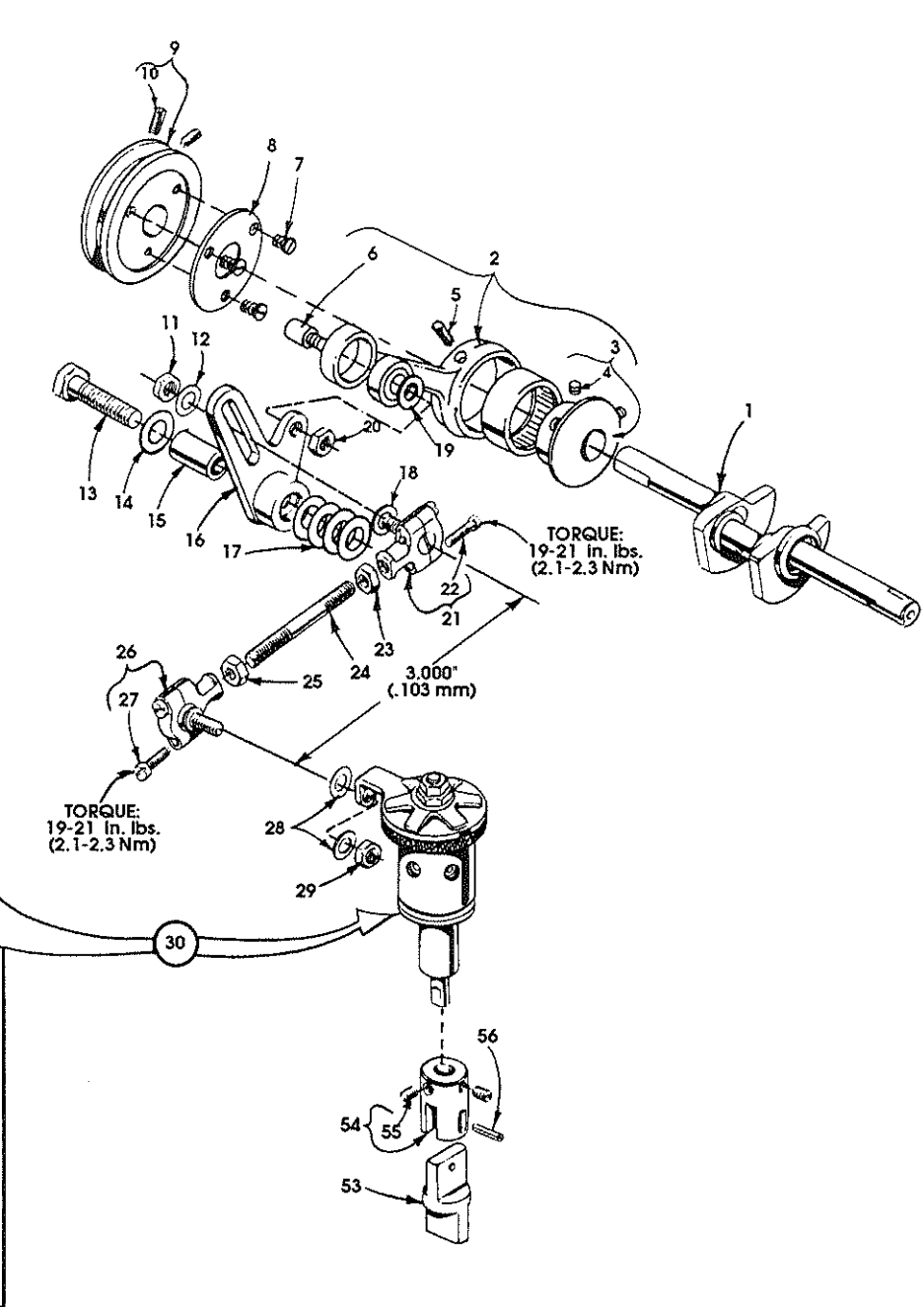
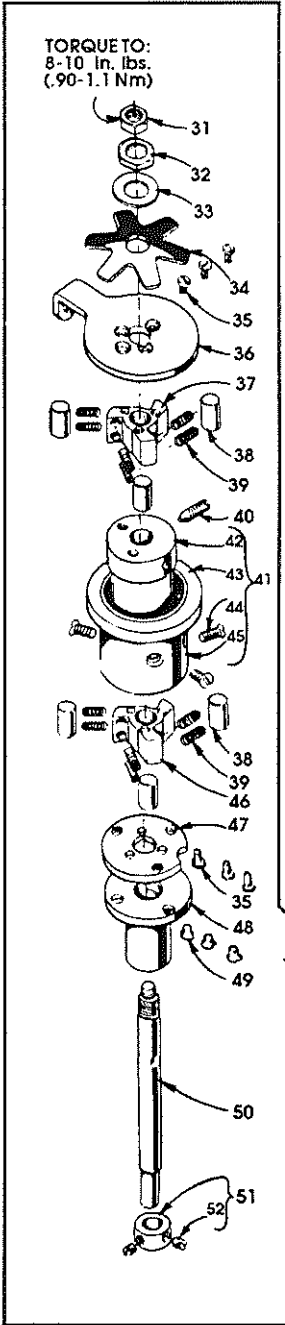

P197-94

PULLEY, CRANKSHAFT, CLUTCH AND CLUTCH DRIVING MECHANISM (CONT.)

Ref. No.	Part No.	Description	Amt. Req.
1. thru 29. See preceding page			
30.	29478 BY	Constant Wedge Angle Clutch Assembly	1
31.	18	Nut	1
32.	11638 M	Nut	1
33.	61351 C	Washer	1
34.	54274 N	Brake Spring	1
35.	605 A	Screw	6
36.	35876 AC	Clutch Drive Lever	1
37.	54274 H	Clutch Disc, upper	1
38.	54274 L	Clutch Roller	6
39.	54274 Y	Clutch Roller Spring	12
40.	22894 H	Spot Screw	1
41.	35876 AB	Barrel Assembly	1
42.	50-835 BLK	Barrel Core	1
43.	35876 AD	Drive Lever Brake	1
44.	538	Screw	3
45.	50-834 BLK	Barrel	1
46.	54274 H	Clutch Disc, lower	1
47.	35876 AG	Locking Spacer Plate	1
48.	35876 AF	Lower Bearing	1
49.	22564	Screw	3
50.	35876 AE	Feed Drive Shaft	1
51.	41363 U	Collar	1
52.	22743	Screw	2
53.	54279	Feed Roller Drive Floating Connection	1
54.	35876 AH	Feed Roller Connection, upper	1
55.	22894 W	Screw	2
56.	660-219	Roll Pin	1

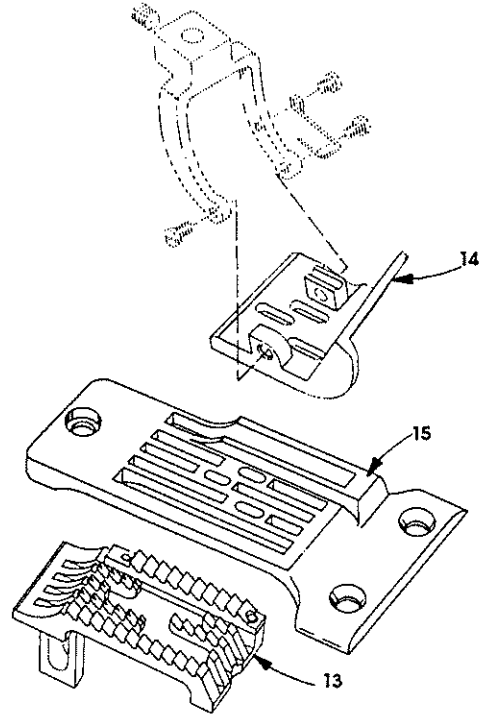
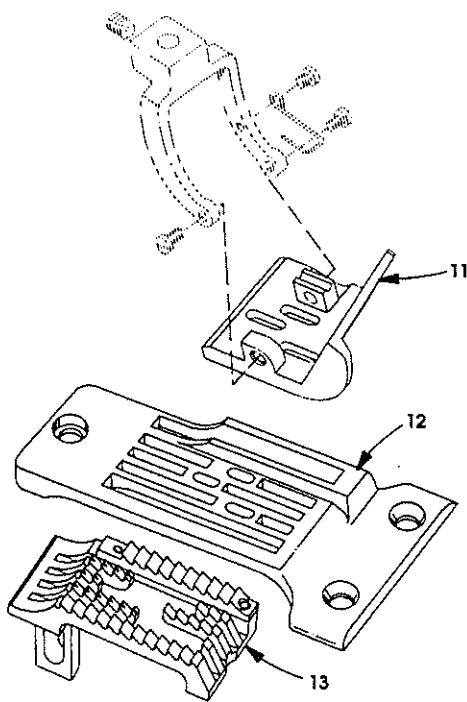
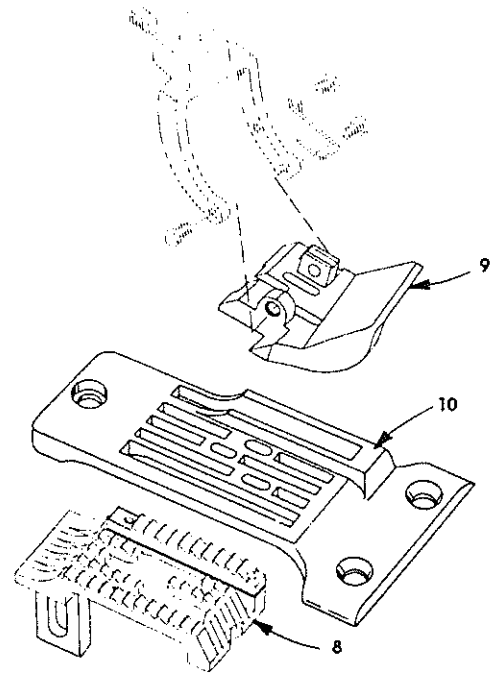
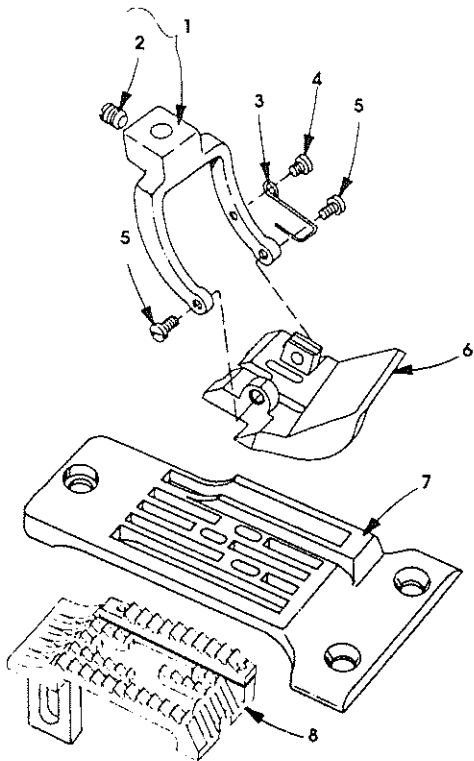

P196-94

PRESSER FOOT, THROAT PLATE, FEED DOGS

Ref. No.	Part No.	Description	Amt. Req.
1.	35874 B	Presser Foot Fork	1
2.	22894 C	Screw	1
3.	35830 K	Spring	1
4.	22599	Screw	1
5.	22845 A	Screw	2
6.	35820 BQW8	Presser Foot, for Style 35800 DQW8	1
7.	35824 BQW8	Throat Plate, for Style 35800 DQW8	1
8.	35805 BQW9	Main Feed Dog, for Styles 35800 DQW8, 9	1
9.	35820 BQW9	Presser Foot, for Style 35800 DQW9	1
10.	35824 BQW9	Throat Plate, for Style 35800 DQW9	1
11.	35830 BXW8	Presser Foot, for Styles 35800 DRW8, DRWL8	1
12.	35824 DQW8	Throat Plate, for Styles 35800 DRW8, DRWL8	1
13.	35805 BRW8	Main Feed Dog, for Styles 35800 DRW8, 9, DRWL8, 9	1
14.	35830 BXW9	Presser Foot, for Styles 35800 DRW9, DRWL9	1
15.	35824 DQW9	Throat Plate, for Styles 35800 DRW9, DRWL9	1

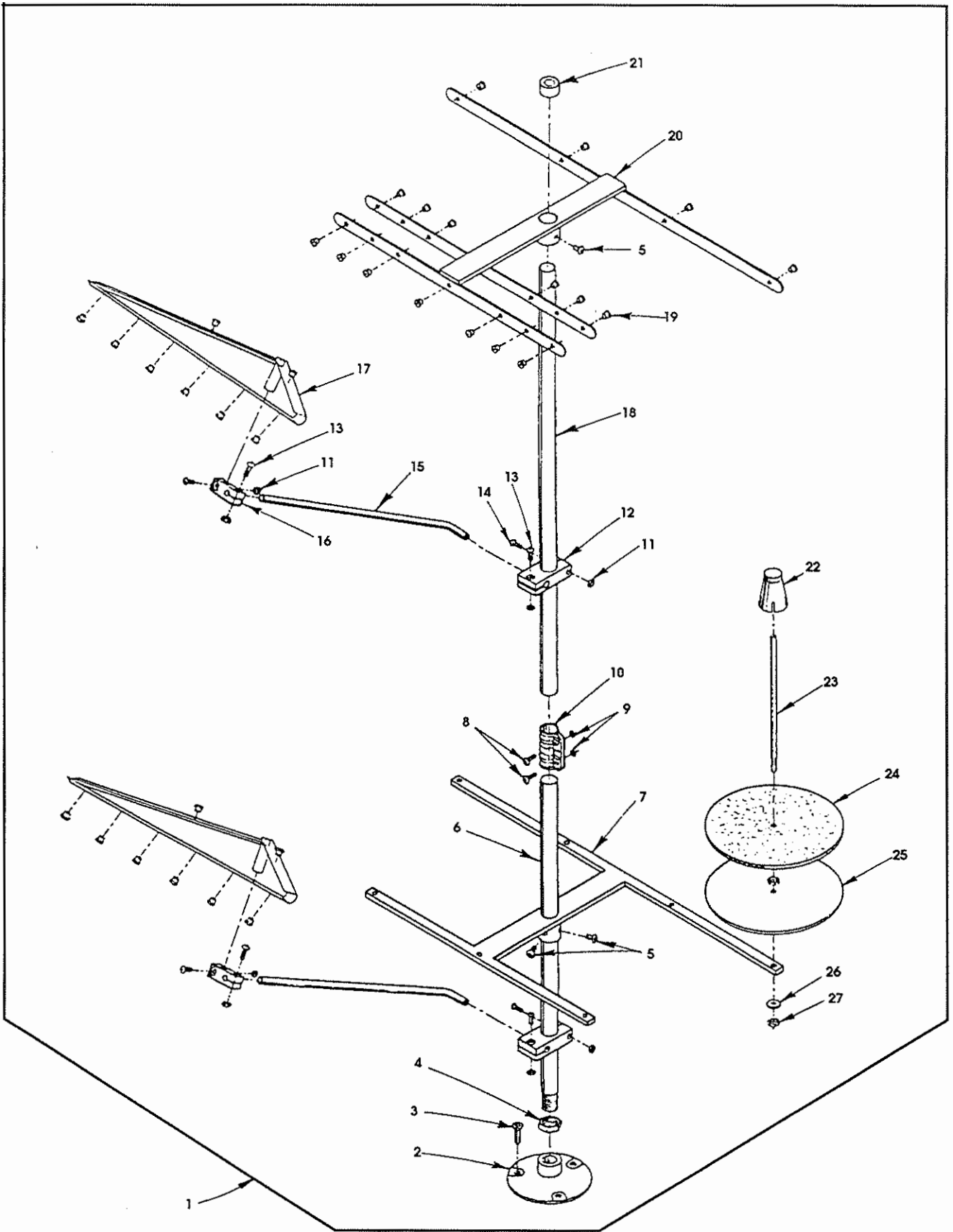

P191-94

THREAD STAND

Ref. No.	Part No.	Description	Amt. Req.
1.	21101 S7	Thread Stand, complete	1
2.		Thread Stand Base	1
3.		Screw	3
4.		Nut	1
5.		Screw	4
6.		Thread Stand Rod, short	1
7.		Base Bracket	1
8.		Screw	2
9.		Nut	2
10.		Joint	1
11.		Nut	8
12.		Holder, large	2
13.		Screw	6
14.		Screw, long	2
15.		Thread Guide Rod	2
16.		Holder, thread guide	2
17.		Thread Guide	2
18.		Thread Stand Rod, long	1
19.		Thread Eyelet	34
20.		Thread Guide	1
21.		Cap	1
22.		Spool Retainer	7
23.		Spool Pin	7
24.		Felt Disc	7
25.		Support Disc	7
26.		Spring Washer	7
27.		Nut	14

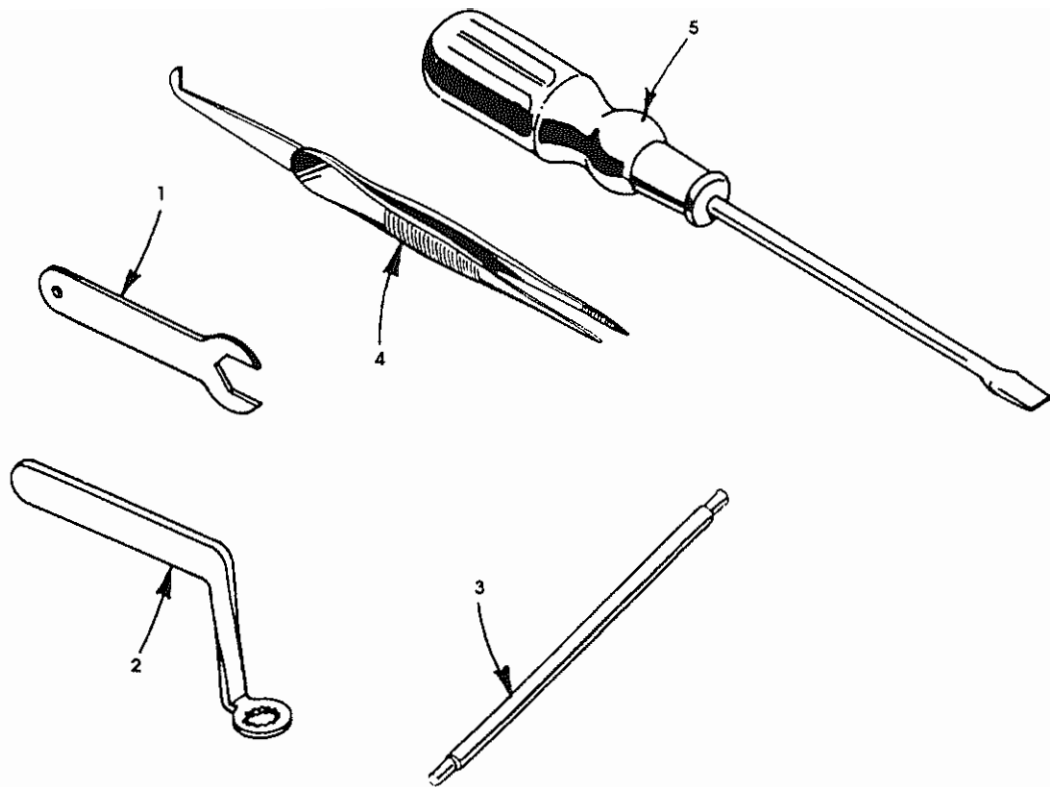

P186-94

ACCESSORIES

Ref. No.	Part No.	Description	Amt. Req.
1.	TT 85	Wrench, for looper avoid	1
2.	21388 AZ	Wrench, for feed bar	1
3.	21227 AR	Needle Head Torque Rod	1
4.	660-240	Thread Tweezers	1
5.	21201	Screwdriver	1
-	28604 R	Oil Can (not shown)	1
-	660-1012	Oil Nozzle (not shown)	1
-	660-457	Plastic Cover (not shown)	1
-	WR 56	Allen Wrench, size 1/4" (not shown)	1
-	WR 58	Allen Wrench, size 3/8" (not shown)	1
-	WR 60	Allen Wrench, size 1/2" (not shown)	1

NUMERICAL INDEX OF PARTS

Part No. Page No.	Part No. Page No.	Part No. Page No.	Part No. Page No.
109.....27	22733 A.....15	35736 A.....21	35834 V-3.....21
110-3.....27	22733 B.....9, 11	35736 B.....21	35835 B.....21
11638 M.....31	22738.....25	35746 A.....21, 23	35836.....21
12934 A.....9, 17	22743.....21, 31	35751.....23	35837 A.....23
12982.....17	22747.....13, 21	35751 B.....23	35837 N.....23
136.....27	22752 B.....23	35751 F.....23	35841 B.....21
14649.....25	22758 C.....25, 27	35751 G.....23	35842.....23
15438 C.....17	22758 E.....17	35760 D.....9	35842 H.....23
18.....21, 23, 29, 31	22759 A.....9	35760 E.....9	35843 B.....21
18-1426.....9	22760 A.....15	35761.....19	35844.....21
20.....29	22764.....21, 25	35761 D.....9	35844 C.....21
21101 S7.....35	22764 A.....25	35763.....19	35844 D.....21
21201.....36	22768.....17, 21	35763 F.....19	35844 E.....21
21227 AR.....36	22784 F.....27	35763 G.....19	35845 D.....21
21237 ES.....25	22797.....19	35766 A.....23	35846.....21
21388 AZ.....36	22798.....13	35767.....17	35847 E.....21
21756 G.....19	22829.....11, 17	35772 S.....11	35848 B.....23
22513.....15, 17	22839 D.....27	35772 T.....11	35848 D.....23
22516 A.....9	22845 A.....33	35781 D.....11	35848 E.....23
22519 F.....19	22849.....15	35792.....27	35849 B.....23
22524.....13, 17	22849 A.....15	35792 T.....27	35850 B.....15
22526.....23	22874 C.....21	35796 B.....13	35850 C.....15
22526 B.....13	22894 C.....17, 25, 29, 33	35796 C.....13	35850 D.....15
22539 C.....15	22894 E.....29	35805 BQW9.....33	35851.....23
22539 D.....15	22894 F.....9	35805 BRW8.....33	35851 A.....23
22539 H.....15	22894 H.....31	35808 AY.....23	35851 G.....23
22539 T.....9	22894 J.....19, 27	35809 AY.....23	35853 AA.....11
22557 A.....17	22894 K.....19	35809 BY.....23	35853 AD.....23
22560 B.....25	22894 W.....25, 31	35815 A.....19	35853 AJ.....23
22561 A.....13	23420 CC 18-1/8.....15	35817 E.....17	35853 AK.....23
22562.....27	23421 CC 18-1/8.....15	35818 BY-8.....17	35853 V-156.....23
22562 A.....19, 23, 27	23422 CC 18-1/8.....15	35818 BY-9.....17	35853 W.....11
22564.....19, 23, 31	23423 V.....15	35820 BQW8.....33	35853 Y.....11
22564 B.....9, 11, 15, 17	23423 W.....15	35820 BQW9.....33	35853 Z.....9
22569 B.....9	23424 S.....15	35821 F.....29	35854.....17
22570.....9	25 B.....17	35821 V.....29	35856 AA.....11
22570 A.....9	258.....21, 23, 29	35822 W.....19, 29	35856 Y.....15
22571 A.....15	258 A.....23	35824 BQW8.....33	35857 W.....25
22571 B.....19	269.....21, 23, 29	35824 BQW9.....33	35859 K.....17
22572.....21	27-435 BLK.....13	35824 DQW8.....33	35859 L.....17
22578 E.....21	28.....11	35824 DQW9.....33	35861 D.....19
22580 A.....21	28604 R.....36	35825 AC.....21	35862.....19
22580 D.....19	29101 G.....21	35826 DZ.....25	35864 F.....17
22585 A.....19	29472 AA.....19	35826 X.....25	35866.....23
22585 C.....25	29472 AC.....19	35829 AC.....17	35869 C.....17
22587 B.....19	29478 AH.....23	35830 BXW8.....33	35869 D.....17
22589.....29	29478 AJ.....23	35830 BXW9.....33	35869 K.....17
22596 B.....19	29478 BD.....19, 21	35830 K.....33	35869 L.....17
22599.....33	29478 BY.....31	35831 C.....25	35870.....17
22644 K-80.....29	29478 DZ.....23	35831 G.....17	35871 A.....9
22653 B-16.....17	29478 ED.....25	35833 C.....25	35871 B.....9
22653 B-8.....17	29480 ALY.....29	35833 D.....25	35873 AH.....25
22653 E-20.....11	318.....17	35833 E.....25	35873 AJ.....25
22711.....11	35704 C.....11	35833 F.....27	35873 AK.....25
22729.....19	35722 AF.....23	35834 G.....21	35873 W.....25
22729 C.....21, 23, 29	35723 C.....19	35834 N.....21	35873 Z.....25
22729 D.....23	35731 A.....17	35834 R.....21	35874 B.....33
22730.....11	35733 B.....25	35834 U.....21	35875 AA.....25
			35875 X.....25
			35875 Y.....25
			35875 Z.....25
			35876 AA.....17
			35876 AB.....31
			35876 AC.....31
			35876 AD.....31
			35876 AE.....31
			35876 AF.....31
			35876 AG.....31
			35876 AH.....31
			35876 U.....11
			35876 V.....29
			35876 W.....29
			35877 AA.....25
			35877 N.....29
			35877 XA.....29
			35877 Z.....29
			35878 F.....27
			35878 H.....27
			35878 S.....25
			35880 L.....27
			35880 N.....27
			35880 P.....27
			35883 A.....13
			35883 E.....13
			35883 F.....13
			35883 G.....13
			35883 H.....13
			35883 J.....13
			35883 M.....13
			35883 V.....13
			35884 D.....13
			35884 E.....13
			35884 F.....13
			35884 H.....13
			35884 P.....15
			35886 B.....15
			35886 C.....15
			35887 AD.....9
			35887 AE.....9
			35887 M.....9
			35887 R.....9
			35887 V.....11
			35887 X.....9
			35887 Z.....11
			35888 L.....27
			35888 M.....27
			35888 NR.....9
			35888 P.....9
			35889 AA.....17
			35889 B.....17
			35889 G.....17
			35889 H.....9
			35889 X.....17
			35889 Y.....17
			35889 Z.....17
			35890 D.....11

NUMERICAL INDEX OF PARTS

<u>Part No.</u> <u>Page No.</u>	<u>Part No.</u> <u>Page No.</u>	<u>Part No.</u> <u>Page No.</u>
35890 E.....11	52888 B.....27	C 067 E.....9
35890 L.....9	531.....13, 15	C 50092 S.....27
35890 M.....9	538.....21, 31	CL 21.....9, 11, 17
35894 K.....19	54274 C.....25	J 87 J.....13
35894 V.....19	54274 H.....31	TT 85.....36
35895 V.....23	54274 L.....31	WO 3.....19
35895 W.....19	54274 N.....31	WR 56.....36
35895 Z.....19	54274 Y.....31	WR 58.....36
35897 AW.....9, 17	54279.....31	WR 60.....36
35897 AX.....15	55287 L.....27	
35897 BM.....19	56341 G.....23	
35897 BU.....19	56354 A.....19	
35897 BV.....19	56390 E.....9	
35897 BW.....19	56392 F.....27	
35897 BY.....19	57 WB.....17	
35897 CC.....19	57 WD.....17	
36 G.....29	6042 A.....9, 17, 29	
36256 B.....15	605.....17	
36261 B.....19	605 A.....31	
36280 U.....25	61256 G.....25	
36280 V.....25	61351 C.....29, 31	
36280 W.....27	642-423 BLK.....15	
36284.....13	660-1012.....36	
36290 B.....11	660-1014.....9	
36292 K.....27	660-1016.....9	
36292 M.....27	660-199.....21	
36292 N.....27	660-206.....9	
36292 P.....27	660-219.....31	
36293 B.....9	660-220.....23	
36293 E.....9	660-221.....21	
36293 F.....9	660-240.....36	
36298 F.....27	660-303.....25	
36298 G.....27	660-310.....23	
376.....21	660-457.....36	
39141.....23	660-548.....21	
39592 AK.....27	660-935.....9	
39593 C.....9	664 F-16.....17	
402.....25	664 F-24.....13	
41071 G.....9	666-149.....19	
41355 U-4.....21	666-186.....29	
41355 U-5.....21	666-47.....21	
41355 U-6.....21	667 B-20.....17	
41355 U-7.....21	667 C-12.....17	
41355 U-8.....21	667 D-16.....13	
41355 U-9.....21	69 H.....17	
41363 U.....31	73 A.....25	
43246.....21	77.....17, 19	
43296.....17	80265.....19	
4761.....29	8372 A.....9	
50-458 BLK.....23	86.....25	
50-537 BLK.....9	87 U.....21	
50-539 BLK.....11	88.....15, 21, 23, 25	
50-834 BLK.....31	89.....17, 23, 25	
50-835 BLK.....31	90.....9, 13, 19	
50342 V.....29	93.....9, 11	
51054.....19	93 A.....9	
51254 J.....19	94.....27	
51292 F-4.....27	98 A.....27	

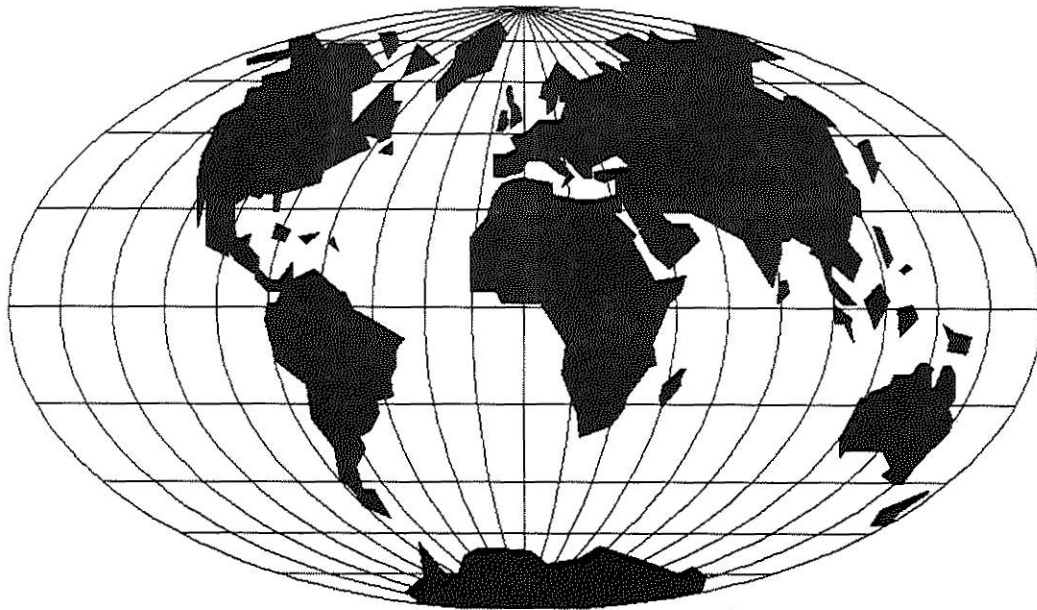

WORLDWIDE SALES AND SERVICE

Union Special Corporation maintains sales and service facilities throughout the world. These offices will aid you in the selection of the right sewing equipment for your particular operation. Union Special Corporation representatives and service technicians are factory trained and are able to serve your needs promptly and efficiently. Whatever your location, there is a qualified representative to serve you.

It is important to remember that LEWIS® machines are also products of Union Special Corporation, thus offering the Finest Quality sewing machines.

Brussels, Belgium
Commerce, CA
Leicester, England
Lille, France
Miami, FL
Möglingen, Germany
Huntley, IL
Milan, Italy
Osaka, Japan
Hong Kong
Charlotte, N.C.
Warminster, PA
Montreal, Quebec
El Paso, TX
Mission, TX

Other Representatives throughout all parts of the world.



Union Special
INDUSTRIAL SEWING EQUIPMENT