

# W600

Cylinderbed Interlock Stitch Machines  
シリンダーベッド扁平縫いミシン

**Parts Catalog**



**PEGASUS®**

## パーツカタログの見方

- このパーツカタログは、2002年3月製造中のW600シリーズのミシンを次の要領で編集しています。
- 2～87頁には部品を機構別に収録し、左頁が部品の分解図、右頁がパーツリストになっています。また、部品分解図に付されている番号は、パーツリストのREF.NO.（参照番号）を示しています。
- パーツリストの部品番号の表記がXXXXXXの部品は、特定の形式（サブクラス）にのみ使用されているゲージパーツ部品で、形式によって変わります。形式ごとの部品番号はゲージパーツ表（88～92頁）に一括して記載しています。
- 巻末には部品番号インデックスを記載し、部品番号だけで、その図解・名称などが容易に引き出せます。
- 部品を御注文いただく時は、部品番号を明示してください。なお、このパーツカタログの記載事項は改良により、予告なく変更されることがありますので、あらかじめ了承ください。

## INTRODUCTION

- This parts catalog covers the W600 series machine manufactured in March, 2002.
- The components of W600 series are arranged according to the mechanism on pages 2-87. The illustrations are on left pages and the part numbers on right pages. The illustrated part and its part number are assigned the same reference number.
- "XXXXXX" indicates gauge part numbers which vary depending on subclasses. Please refer to the gauge part list (pages 88-92).
- The index of part numbers are listed at the back of this book for quick reference.
- To place an order for any part, please specify the part number. Note that the contents of this book are subject to change without notice.

### 掲載機種 (Models covered)

#### W664 Series

---

W664-01EB,01GB,01HB,01MC

---

W664-02GB

---

W664-03FB,03FC,03GB,03GC,03KB,03LB,03MC

---

W664-05BA,05BB,05MC

---

W664-08AB,08AC,08BB,08BC,08DC,08EC,08HB,08MB,08MC,08NC

---

W664-30AB,30AC

---

W664-32AB,32BB,32AC,32BC,32DB,32DC,32EC

---

W664-33AB,33BB,33AC,33BC

---

W664-34AB,34AC

---

W664-35AB,35BB,35AC,35BC,35DC,35NB,35MC,35NC

---

W664-71AB,71AC

---

W664-81AB,AC

---

## 目次

	頁
アームベッド機構	2~3
カバー機構(1)	4~5
カバー機構(2)	6~7
下軸機構	8~9
上軸機構	10~11
針棒・針受機構	12~13
ルーパー機構	14~15
送り機構(1)	16~17
送り機構(2)	18~19
送り機構(3)	20~21
押エ機構	22~23
飾り振り機構	24~25
糸調子機構	26~27
針糸、飾り糸機構	28~29
下糸繰り機構	30~31
給油機構(1)	32~33
給油機構(2)	34~35
H.R.装置	36~37
据付附属品	38~39
糸立台	40~41
専用付属品(1) W664-01	42~43
専用付属品(2) W664-02	44~45
専用付属品(3) W664-03	46~47
専用付属品(4) W664-05/FT240,240A	48~49
専用付属品(5) W664-08	50~51
専用付属品(6) W664-30,32,33,34,35	52~53
専用付属品(7) W664-30	54~55
専用付属品(8) W664-32	56~57
専用付属品(9) W664-33A/FT221/FT241,33B/FT222/FT242A	58~59
専用付属品(10) W664-34,35	60~61
専用付属品(11) W664-71	62~63
専用付属品(12) W664-81	64~65
専用付属品(13) W664-01M,03M,05M,08M,08N,35M,35N	66~67
FT装置 W664-05,33	68~69
FT装置(1) W664-33	70~71
FT装置(2) W664-33	72~73
FT装置 W664-34A,35A,35B	74~75
布張りローラー装置(1) W664-30,34A	76~77
布張りローラー装置(2) W664-32	78~79
布張りローラー装置(3) W664-33	80~81
ゴム付装置 W664-33	82~83
RP装置(1)	84~85
RP装置(2)	86~87
ゲージパーツ表	88~92
部品番号インデックス	94~97

## TABLE OF CONTENTS

	page
MACHINE BED FRAME	2~3
COVER (1)	4~5
COVER (2)	6~7
CRANKSHAFT DRIVE MECHANISM	8~9
ARM SHAFT MECHANISM	10~11
NEEDLE BAR / GUARD MECHANISM	12~13
LOOPER DRIVE MECHANISM	14~15
FEED MECHANISM (1)	16~17
FEED MECHANISM (2)	18~19
FEED MECHANISM (3)	20~21
PRESSER FOOT MECHANISM	22~23
SPREADER MECHANISM	24~25
THREAD TENSION MECHANISM	26~27
NEEDLE & SPREADER THREAD HANDLING	28~29
LOOPER THREAD HANDLING	30~31
LUBRICATION MECHANISM (1)	32~33
LUBRICATION MECHANISM (2)	34~35
H.R. DEVICE	36~37
INSTALLATION PARTS	38~39
THREAD STAND	40~41
SPECIFIC PARTS (1) W664-01	42~43
SPECIFIC PARTS (2) W664-02	44~45
SPECIFIC PARTS (3) W664-03	46~47
SPECIFIC PARTS (4) W664-05/FT240,240A	48~49
SPECIFIC PARTS (5) W664-08	50~51
SPECIFIC PARTS (6) W664-30,32,33,34,35	52~53
SPECIFIC PARTS (7) W664-30	54~55
SPECIFIC PARTS (8) W664-32	56~57
SPECIFIC PARTS (9) W664-33A/FT221/FT241,33B/FT222/FT242A	58~59
SPECIFIC PARTS (10) W664-34,35	60~61
SPECIFIC PARTS (11) W664-71	62~63
SPECIFIC PARTS (12) W664-81	64~65
SPECIFIC PARTS (13) W664-01M,03M,05M,08M,08N,35M,35N	66~67
FT DEVICE W664-05,33	68~69
FT DEVICE (1) W664-33	70~71
FT DEVICE (2) W664-33	72~73
FT DEVICE W664-34A,35A,35B	74~75
FABRIC TENSIONER DEVICE (1) W664-30,34A	76~77
FABRIC TENSIONER DEVICE (2) W664-32	78~79
FABRIC TENSIONER DEVICE (3) W664-33	80~81
ELASTIC ATTACHING DEVICE W664-33	82~83
RP DEVICE (1)	84~85
RP DEVICE (2)	86~87
GAUGE PARTS LIST	88~92
PART NUMBER INDEX	94~97

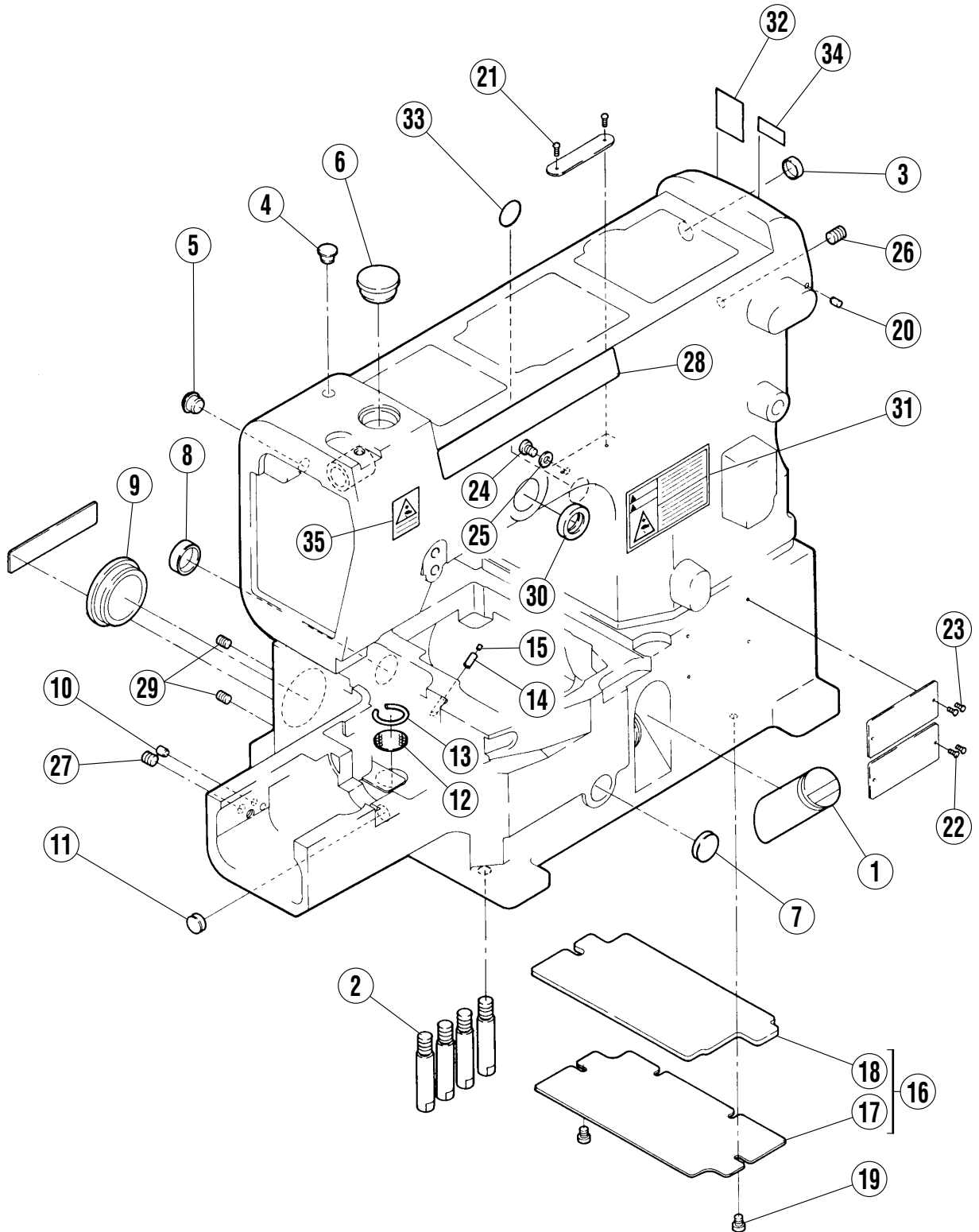

## アームベット機構

## MACHINE BED FRAME

REF.NO.	PART NO.	部品名称	DESCRIPTION	QT.
1	2065900	オイルゲージ	OIL LEVEL GAUGE	1
2	2501170	足ピン	BED PIN	4
3	2402280	栓	PLUG	1
4	2400520	栓	PLUG	1
5	2402270	栓	PLUG	1
6	2401100	栓	PLUG	1
7	2100031	栓	PLUG	1
8	2090840	蓋	COVER	1
9	2402261	栓	PLUG	1
10	2400450	栓	PLUG	1
11	2050881	栓	PLUG	1
12	2501480	フィルタ	FILTER	1
13	2400010	止メ輪	RING	1
14	2551080	テーパーピン	PIN	1
15	2073580	フェルト	FELT	1
16	250158-910	カバー	COVER	1
17	2500200	カバー	COVER	1
18	2501570	スポンジ	SPONGE	1
19	007017A0	平ネジ/M4×5	SCREW	2
20	2401270	合マーク	MARK	1
21	2106790	ピン	PIN	2
22	2106790	ピン	PIN	2
23	2106790	ピン	PIN	2
24	007018A0	平ネジ/M4×6	SCREW	1
25	3034480	座金	WASHER	1
26	0045410	止ネジ/M6×8	SCREW	1
27	0045220	止ネジ/M6×6	SCREW	1
28	2503880	銘板	NAME PLATE	1
29	0045390	止ネジ/M5×6	SCREW	2
30	2105860	オイルシール	OIL SEAL	1
31	9A30670	シール	SEAL	1
32	9A30690	ケガ注意ラベル	CAUTION LABEL	1
33	9A30710	シール	SEAL	1
34	9A30720	シール	SEAL	1
35	9A30690	ケガ注意ラベル	CAUTION LABEL	1

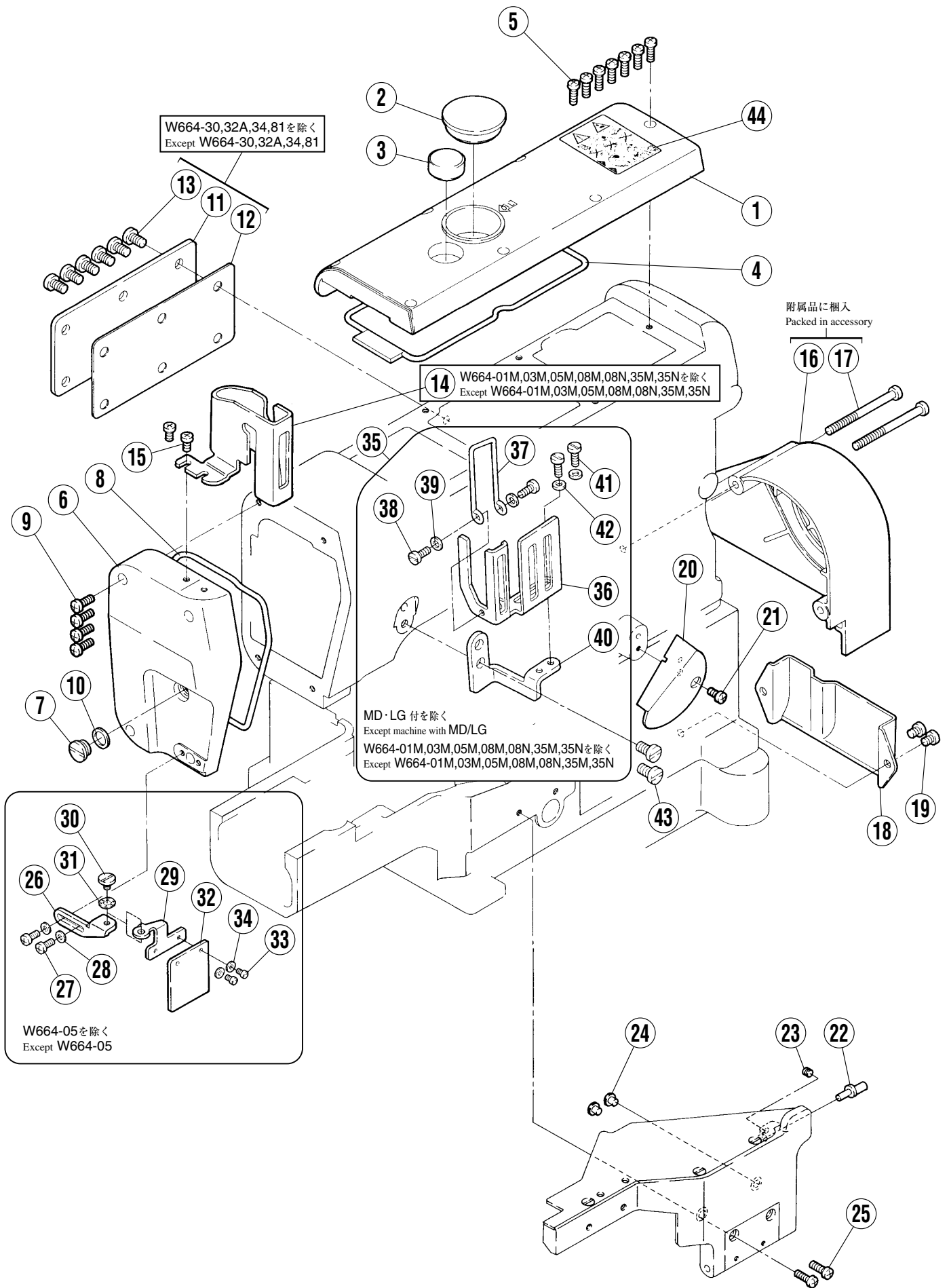

## カバ-機構(1)

## COVER(1)

REF.NO.	PART NO.	部品名称	DESCRIPTION	QT.
1	250150-PD0	ア-ムカバ- (上)	ARM COVER (TOP)	1
2	2402261	栓	PLUG	1
3	179107-050	オイル窓	OIL SIGHT WINDOW	1
4	2500190	Oリング	O RING	1
5	007021A0	平ネジ/M4×12	SCREW	7
6	250151BTD0	ア-ムカバ- (左)	ARM COVER (LEFT)	1
7	0052420	平ネジ/H11×5	SCREW	1
8	2501530	Oリング	O RING	1
9	007021A0	平ネジ/M4×12	SCREW	4
10	2402630	座金	WASHER	1
11	2501540	ア-ムカバ- (後)	ARM COVER (REAR)	1
12	2501550	ガスケット	GASKET	1
13	0070520	平ネジ/M6×10	SCREW	6
14	250224A0	針棒ガード	NEEDLE BAR GUARD	1
15	007019A0	平ネジ/M4×8	SCREW	2
16	250156-TB0	プ-リーカバ-	PULLEY COVER	1
17	0070750	平ネジ/M5	SCREW	2
18	2501590	風案内	AIR GUIDE	1
19	0070790	平ネジ/M5×6	SCREW	2
20	250234-TD0	下糸道カバ-	LOOPER THREAD GUIDE COVER	1
21	007019A0	平ネジ/M4×8	SCREW	1
22	2501810	エキセンピン	ECCENTRIC PIN	1
23	0045430	止ネジ/M4×4	SCREW	1
24	2100250	振動止メ	CUSHION	2
25	007022A0	平ネジ/M4 X 14	SCREW	2
26	2502550	ブラケット	BRACKET	1
27	007020A0	平ネジ/M4×10	SCREW	2
28	3034480	座金	WASHER	2
29	2502560	ブラケット	BRACKET	1
30	0070660	段付ネジ/M4	SCREW	1
31	2103070	波板座金	WASHER	1
32	2502570	アイガード	EYE GUARD	1
33	0070090	平ネジ/M3×5	SCREW	2
34	2028750	座金	WASHER	2
35	250231A910	糸繰リガード (組)	THREAD TAKE-UP GUARD ASSEMBLY	1
36	2502250	糸繰リガード	THREAD TAKE-UP GUARD	1
37	2502260	フィンガ-ガード	FINGER GUARD	1
38	0070180	平ネジ/M4×6	SCREW	2
39	3034480	座金	WASHER	2
40	250227A0	ブラケット	BRACKET	1
41	0070180	平ネジ/M4×6	SCREW	2
42	3034480	座金	WASHER	2
43	0070520	平ネジ/M6×10	SCREW	2
44	9A31260	シ-ル	SEAL	1

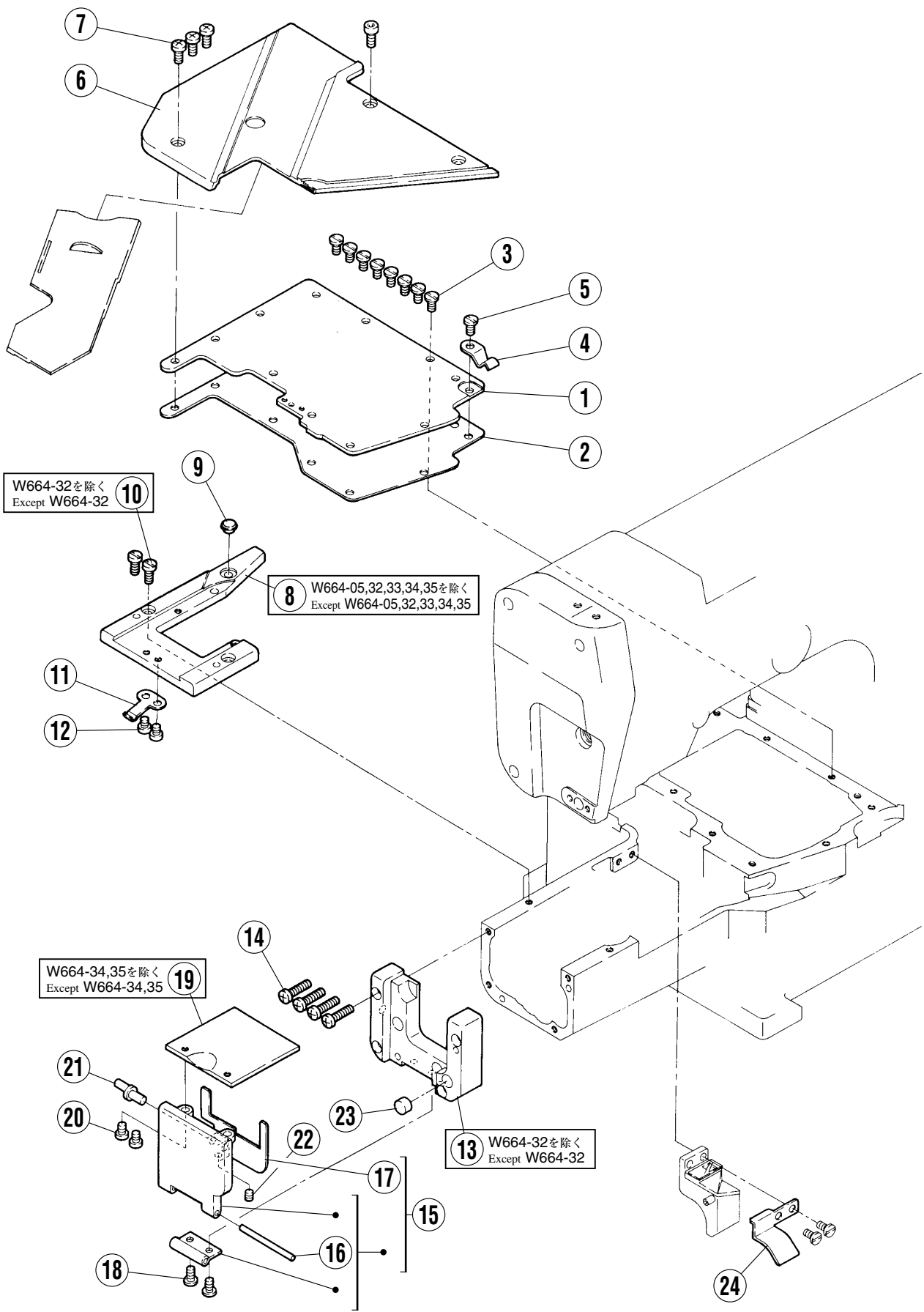



## カバー機構(2)

## COVER(2)

REF.NO.	PART NO.	部品名称	DESCRIPTION	QT.
1	2501600	上蓋	TOP COVER	1
2	2501610	ガスケット	GASKET	1
3	0070820	平ネジ/M4×8	SCREW	8
4	2501800	板バネ	FLAT SPRING	1
5	0070820	平ネジ/M4×8	SCREW	1
6	250162-PD0	平カバー	BED COVER	1
7	0070200	平ネジ/M4×10	SCREW	3
8	2501680	針板ブラケット	NEEDLE PLATE BRACKET	1
9	2100250	振動止め	CUSHION	1
10	0070200	平ネジ/M4×10	SCREW	2
11	2501760	板バネ	FLAT SPRING	1
12	007017A0	平ネジ/M4×5	SCREW	2
13	250280-PD0	横カバー	SIDE COVER	1
14	007024A0	平ネジ/M4×18	SCREW	4
15	250200-9P0	蓋(組)ノ横カバー	COVER PLATE ASSEMBLY	1
16	2501730	平行ピン	PIN	1
17	2501740	ガスケット	GASKET	1
18	0070820	平ネジ/M4×8	SCREW	2
19	2501750	クロスプレート	CLOTH PLATE	1
20	007018A0	平ネジ/M4×6	SCREW	2
21	2501810	エキセンピン	ECCENTRIC PIN	1
22	0045370	止ネジ/M4×5	SCREW	1
23	2402280	栓	PLUG	1
24	2501830	カバー(HR油除け)	COVER	1

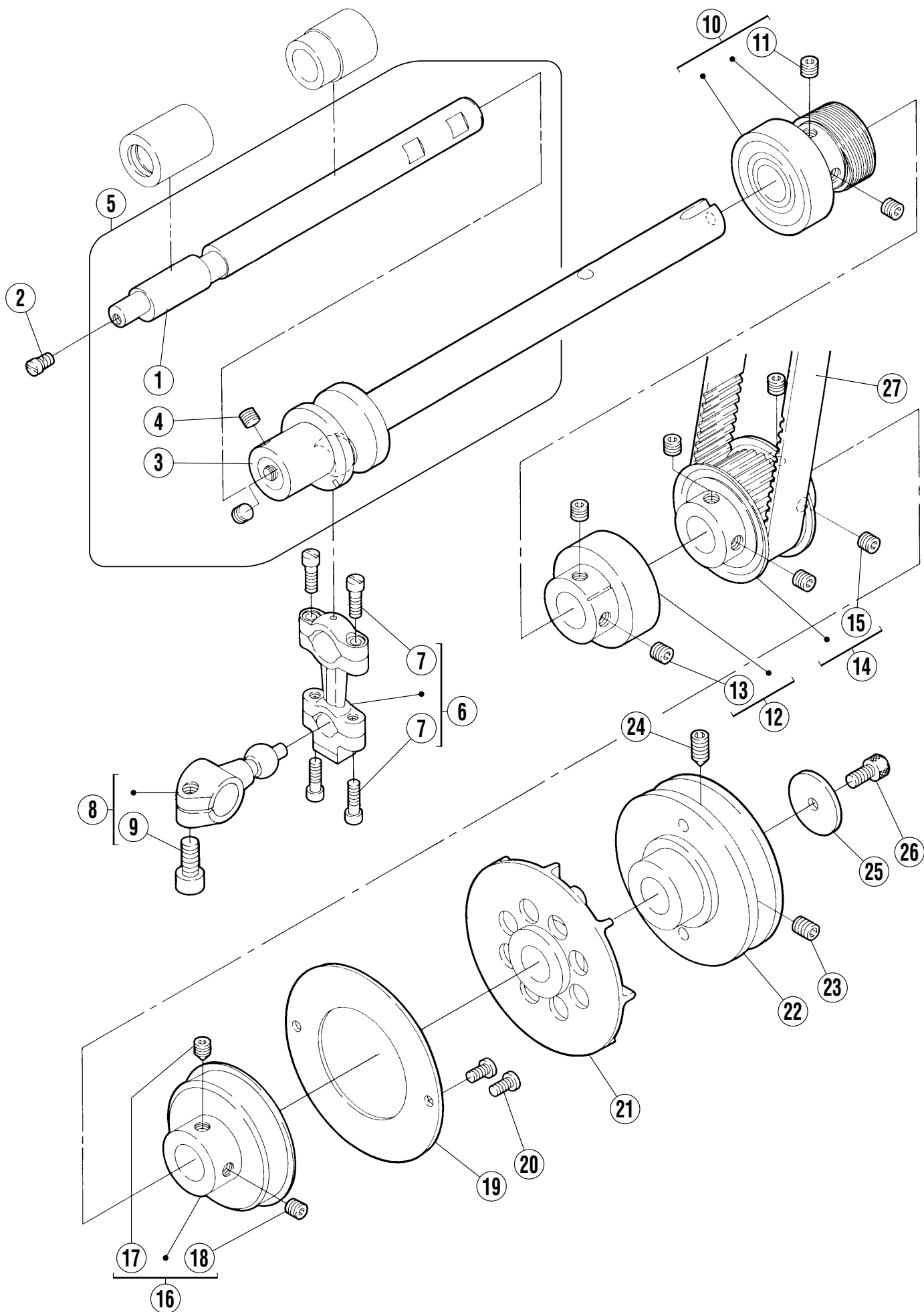

下軸機構

CRANKSHAFT DRIVE MECHANISM

REF.NO.	PART NO.	部品名称	DESCRIPTION	QT.
1	2505510	下軸	CRANKSHAFT	1
2	0070360	平ネジ/M4×6	SCREW	1
3	250554-920	クランク軸	CRANKSHAFT	1
4	0071280	止ネジ/M6×4	SCREW	2
5	250555-910	クランク軸 (組)	CRANKSHAFT ASSEMBLY	1
6	210091-920	ロッド	CONNECTION	1
7	0053760	平ネジ/C4×12.5	SCREW	4
8	252056-920	クランク	CRANK	1
9	0045340	六角穴ボルト/M6×14	BOLT	1
10	250557-910	軸受 (ブッシュ)	BUSHING	1
11	0045470	止ネジ/M6×5	SCREW	2
12	250529A910	軸受 (ブッシュ)	BUSHING	1
13	0045470	止ネジ/M6×5	SCREW	2
14	250545-910	ギヤ (下)	GEAR (LOWER)	1
15	0045470	止ネジ/M6×5	SCREW	4
16	250530-910	軸受 (ブッシュ)	BUSHING	1
17	0045550	止ネジ/M6×8	SCREW	1
18	0045470	止ネジ/M6×5	SCREW	1
19	2505140	止メ板	SET PLATE	1
20	0070820	平ネジ/M4×8	SCREW	2
21	2505560	ファン	FAN	1
22	2505610	プーリー	MACHINE PULLEY	1
23	0045410	止ネジ/M6×8	SCREW	1
24	0045560	止ネジ/M6×10	SCREW	1
25	2401260	座金	WASHER	1
26	0045000	六角穴ボルト/M5×10	BOLT	1
27	206050C0	タイミングベルト	TIMING BELT	1

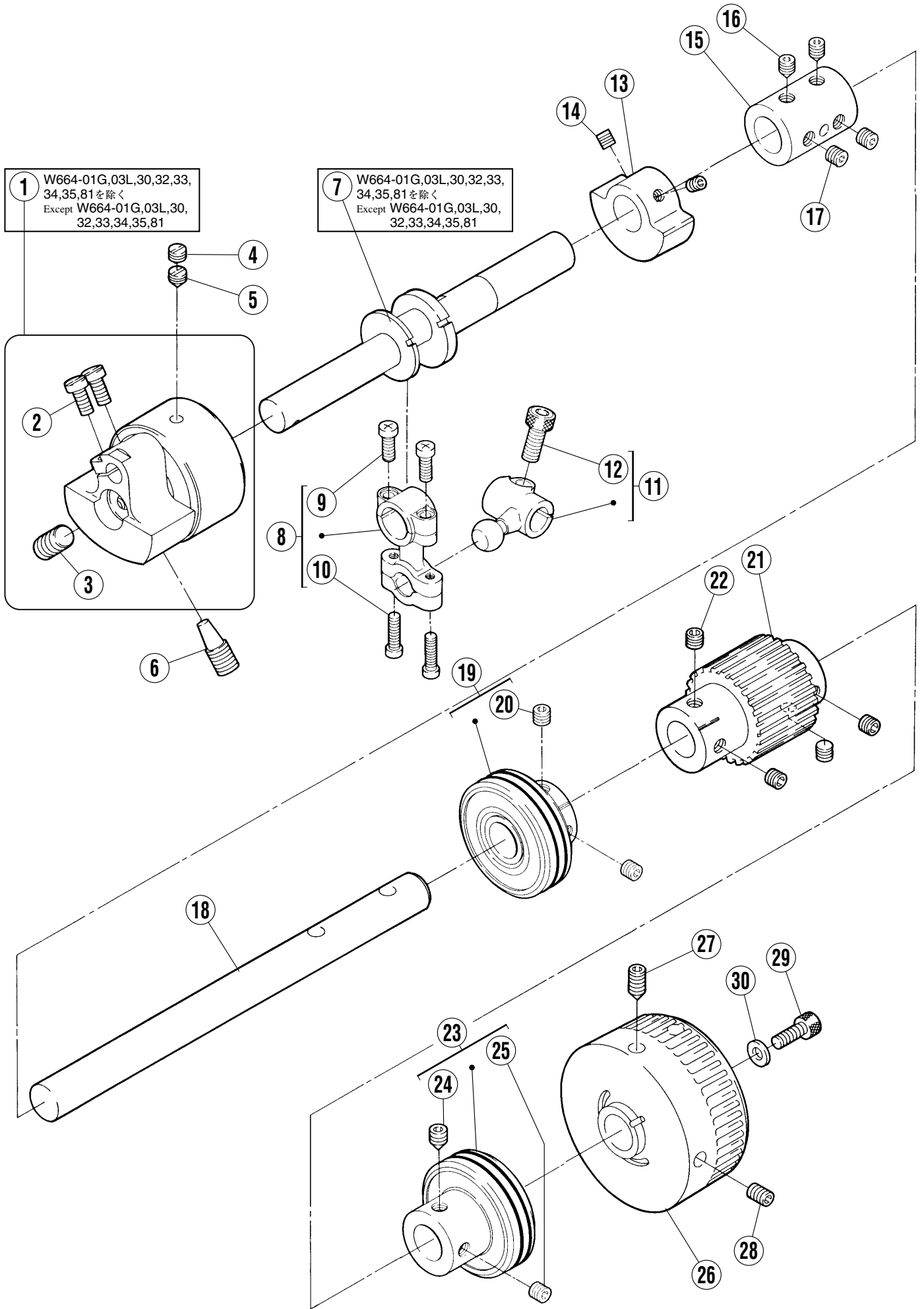

## 上軸機構

## ARM SHAFT MECHANISM

REF.NO.	PART NO.	部品名称	DESCRIPTION	QT.
1	250526B910	モーション (組)	MOTION ASSEMBLY	1
2	0070280	平ネジ/M5×10	SCREW	2
3	0045920	止ネジ/M6×12	SCREW	1
4	0071520	止ネジ/M6×4	SCREW	1
5	0071530	止ネジ/M6×6	SCREW	1
6	0072680	止ネジ/M8×10	SCREW	1
7	250560A0	クランク軸	CRANKSHAFT	1
8	253500-920	ロッド (組)	CONNECTION ASSEMBLY	1
9	007021A0	平ネジ/M4×12	SCREW	2
10	007015A0	平ネジ/M3.5×14	SCREW	2
11	253501A920	クランク (組)	CRANK ASSEMBLY	1
12	0045340	六角穴ボルト/M6×14	BOLT	1
13	2505240	バランスウエイト	BALANCE WEIGHT	1
14	0045140	止ネジ/M5×5	SCREW	2
15	2505060	継手	JOINT	1
16	0045550	止ネジ/M6×8	SCREW	2
17	0045470	止ネジ/M6×5	SCREW	2
18	2505520	軸	SHAFT	1
19	250529-910	軸受 (ブッシュ)	BUSHING	1
20	0045470	止ネジ/M6×5	SCREW	2
21	250547A0	ギヤ (上)	GEAR (UPPER)	1
22	0045470	止ネジ/M6×5	SCREW	4
23	250528-910	軸受 (ブッシュ)	BUSHING	1
24	0045550	止ネジ/M6×8	SCREW	1
25	0045470	止ネジ/M6×5	SCREW	1
26	250566-TD0	ハンドホイール	HANDWHEEL	1
27	0045410	止ネジ/M6×8	SCREW	1
28	0045560	止ネジ/M6×10	SCREW	1
29	0045010	六角穴ボルト/M5×14	BOLT	1
30	2045850	座金	WASHER	1

5 W664-01G,03L,30,32,33,  
34,35,81を除く  
Except W664-01G,03L,30,  
32,33,34,35,81

7 W664-01G,03L,30,32,33,  
34,35,81を除く  
Except W664-01G,03L,30,  
32,33,34,35,81

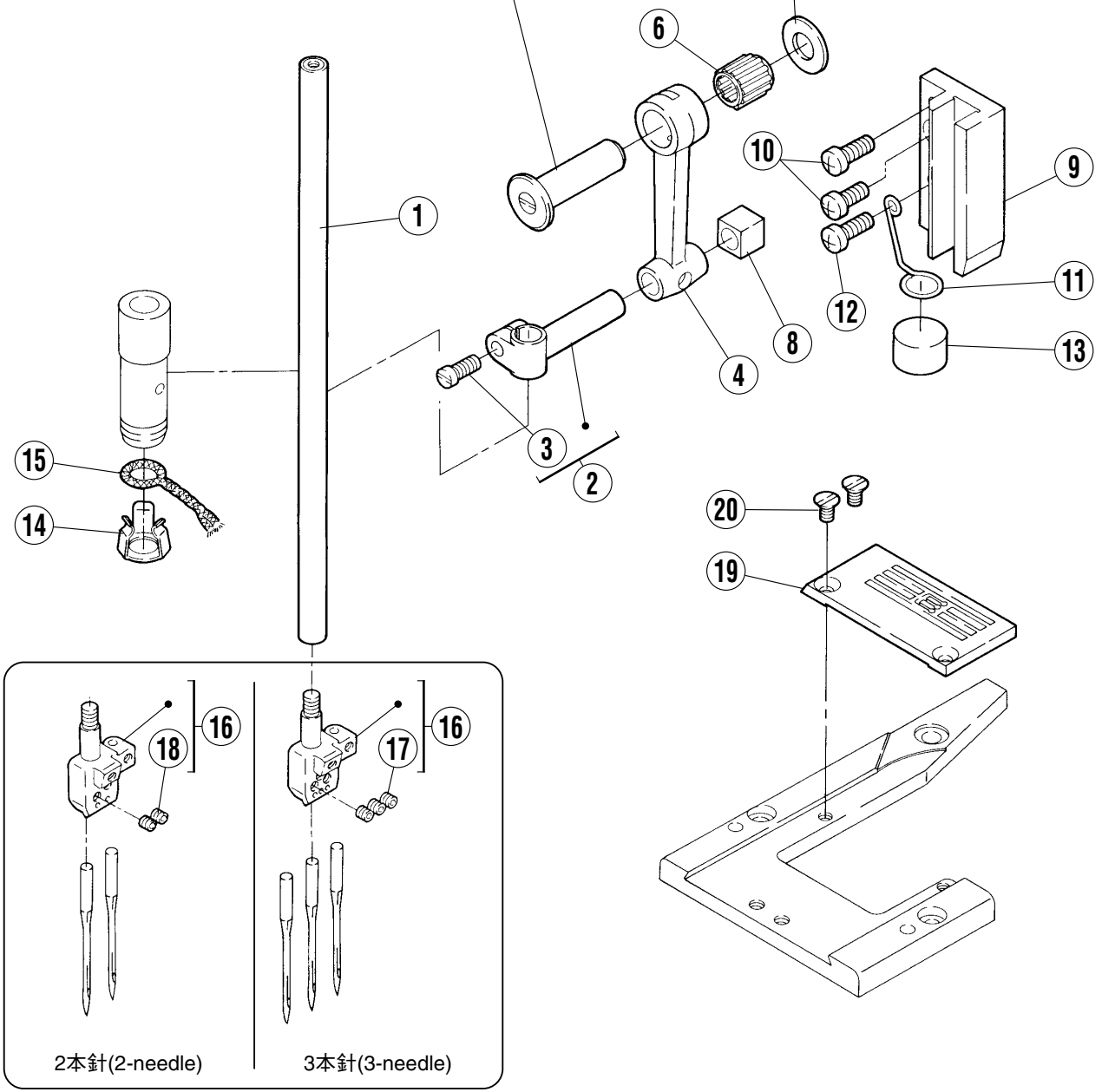

2本針(2-needle)

3本針(3-needle)

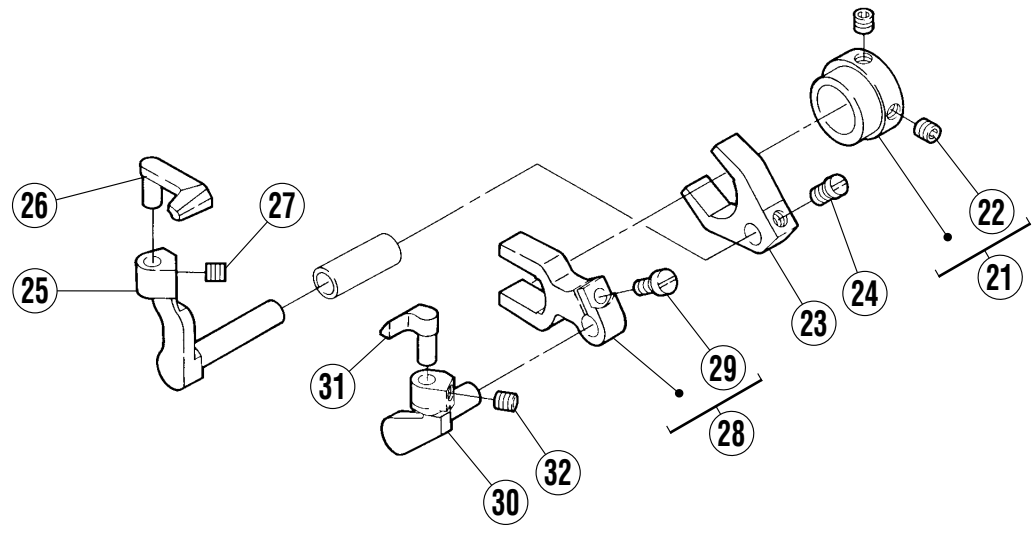

針棒・針受機構

NEEDLE BAR/GUARD MECHANISM

REF.NO.	PART NO.	部品名称	DESCRIPTION	QT.
1	251014-910	針棒	NEEDLE BAR	1
2	2060610	針棒抱キ	NEEDLE BAR CLAMP	1
3	0053250	平ネジ/C5×10	SCREW	1
4	2510160	リンク	LINK	1
5	2060530	段付ピン	PIN	1
6	240098-20	ニードルベアリング	NEEDLE BEARING	1
7	2401010	座金	WASHER	1
8	2060630	角駒	BLOCK	1
9	2510171	案内	GUIDE	1
10	007021A0	平ネジ/M4×10	SCREW	2
11	2510180	ラッチ	LATCH	1
12	007021A0	平ネジ/M4×12	SCREW	1
13	179040-050	スポンジ	SPONGE	1
14	2065240	止メ金	OIL STRING RETAINER	1
15	2121860	給油紐	OIL STRING	1
16	XXXXXX	針留	NEEDLE HOLDER	1
17	0045540	止ネジ/M3×3	SCREW	3
18	0045540	止ネジ/M3×3	SCREW	2
19	XXXXXX	針板	NEEDLE PLATE	1
20	005511-HC0	皿ネジ/C4×6.5	SCREW	2
21	251510-920	エキセン	ECCENTRIC	1
22	0045430	止ネジ/M4×4	SCREW	2
23	2515110	レバー	LEVER	1
24	0070860	平ネジ/M4×7	SCREW	1
25	2515120	針受台 (後)	NEEDLE GUARD HOLDER (REAR)	1
26	XXXXXX	針受 (後)	NEEDLE GUARD (REAR)	1
27	0045430	止ネジ/M4×4	SCREW	1
28	251513-920	レバー	LEVER	1
29	0070130	平ネジ/M3.5×8	SCREW	1
30	2515140	針受台 (前)	NEEDLE GUARD HOLDER (FRONT)	1
31	XXXXXX	針受 (前)	NEEDLE GUARD (FRONT)	1
32	0045430	止ネジ/M4×4	SCREW	1

●XXXXXXはゲージパーツです。  
部品番号は88～92頁のゲージパーツ表を  
参照してください。

●"XXXXXX" represents the gauge part.  
Please refer to the gauge part list (page 88-92).

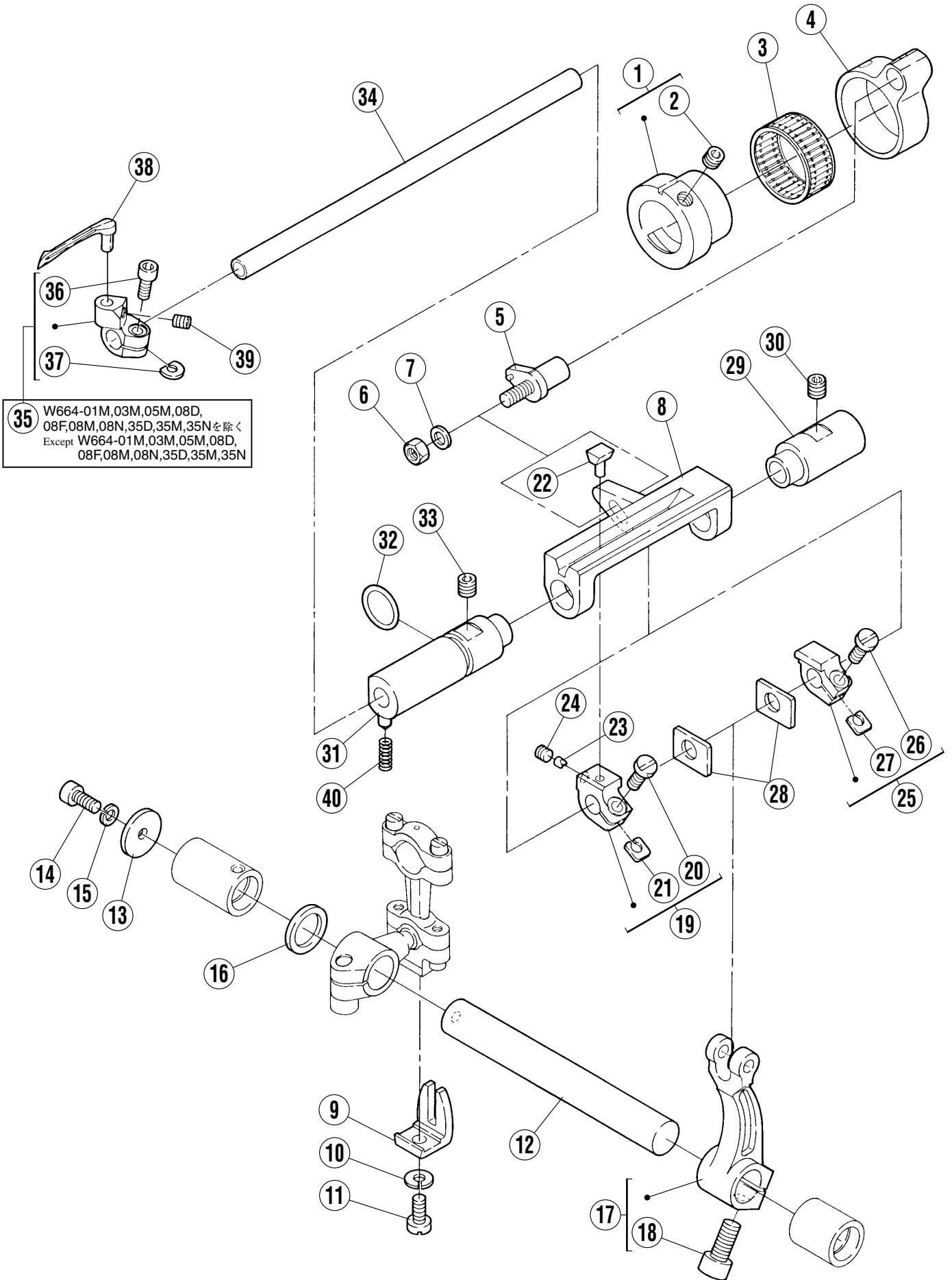



ルーパー機構

LOOPER DRIVE MECHANISM

REF.NO.	PART NO.	部品名称	DESCRIPTION	QT.
1	252036-920	エキセン	ECCENTRIC	1
2	0045470	止ネジ/M6×5	SCREW	1
3	206172-20	ニードルベアリング	NEEDLE BEARING	1
4	2520350	ロッド	ROD	1
5	252037-910	段付ピン (組)	PIN ASSEMBLY	1
6	0048050	六角ナット/M5	NUT	1
7	2400620	座金	WASHER	1
8	2520390	ルーパー軸案内	LOOPER SHAFT GUIDE	1
9	201074A0	振れ止め	GUIDE	1
10	2022860	バネ座金	SPRING WASHER	1
11	0055460	平ネジ/C5×10	SCREW	1
12	2520440	軸	SHAFT	1
13	2402320	座金	WASHER	1
14	0045240	六角穴ボルト/M4×10	BOLT	1
15	2012520	バネ座金	SPRING WASHER	1
16	2402310	座金	WASHER	1
17	252046-920	レバー	LEVER	1
18	0045340	六角穴ボルト/M6×14	BOLT	1
19	252040-920	ホルダー	HOLDER	1
20	0070210	平ネジ/M4×12	SCREW	1
21	2520410	座金	WASHER	1
22	2520420	スライダー	SLIDER	1
23	2520430	ピン	PIN	1
24	0045430	止ネジ/M4×4	SCREW	1
25	252045-920	ホルダー	HOLDER	1
26	0070210	平ネジ/M4×12	SCREW	1
27	2520410	座金	WASHER	1
28	2520470	座金	WASHER	2
29	2520520	ブッシュ	BUSHING	1
30	0045220	止ネジ/M6×6	SCREW	1
31	252049-910	ブッシュ (組)	BUSHING ASSEMBLY	1
32	2310110	Oリング	O RING	1
33	0045220	止ネジ/M6×6	SCREW	1
34	2520480	軸	SHAFT	1
35	252053-920	ルーパー台	LOOPER HOLDER	1
36	0071450	六角穴ボルト	BOLT	1
37	2520550	座金	WASHER	1
38	XXXXXX	ルーパー	LOOPER	1
39	0071290	止ネジ/M4×5	SCREW	1
40	2401310	圧縮バネ	SPRING	1

●XXXXXXはゲージパーツです。  
部品番号は88~92頁のゲージパーツ表を  
参照してください。

●"XXXXXX" represents the gauge part.  
Please refer to the gauge part list (page 88-92).

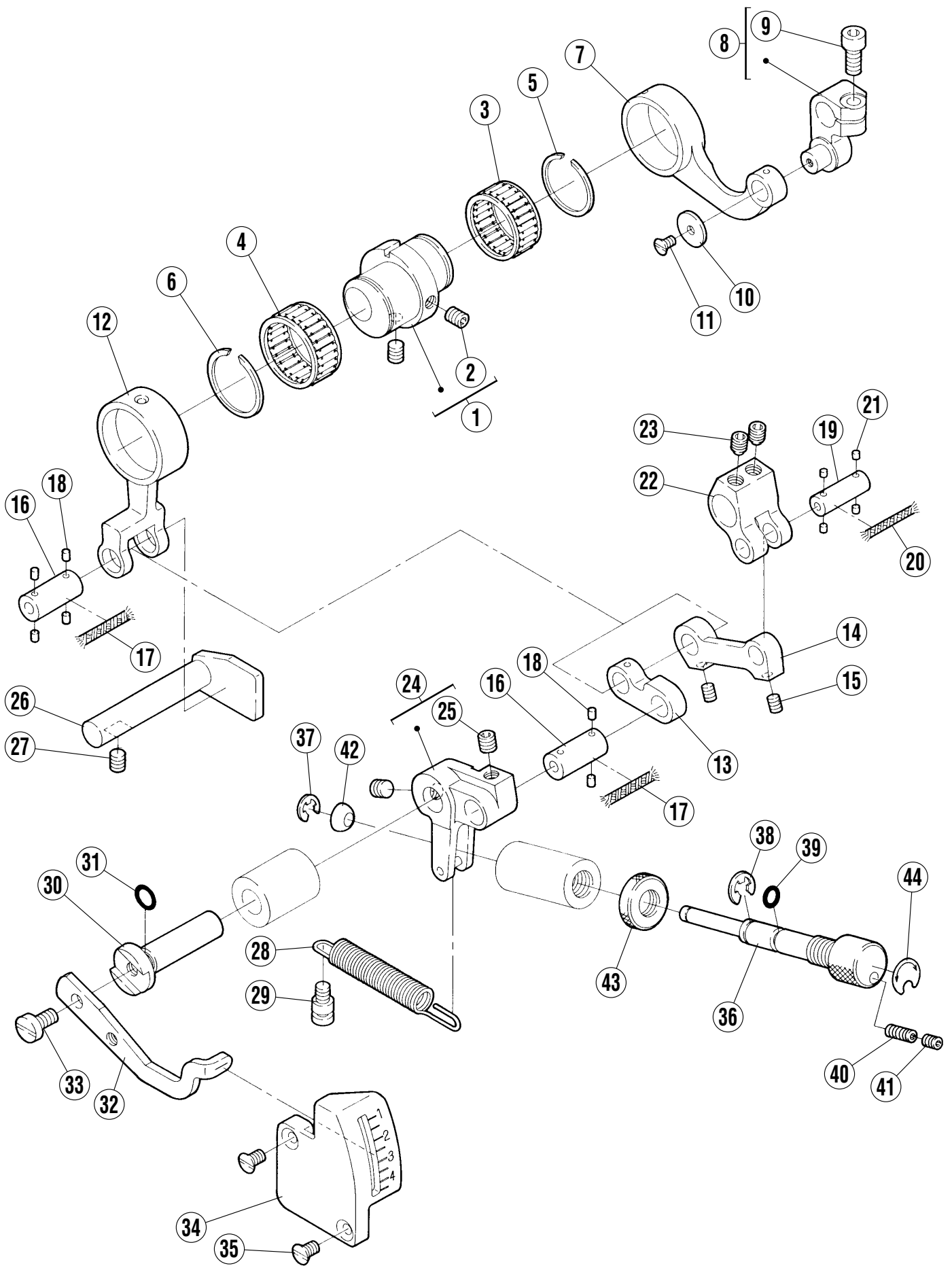

## 送り機構(1)

## FEED MECHANISM(1)

REF.NO.	PART NO.	部品名称	DESCRIPTION	QT.
1	252607-920	エキセン	ECCENTRIC	1
2	0045390	止ネジ/M5×6	SCREW	2
3	204084-20	ニードルベアリング	NEEDLE BEARING	1
4	240236-20	ニードルベアリング	NEEDLE BEARING	1
5	2402340	止メ輪	RING	1
6	2402370	止メ輪	RING	1
7	2526080	ロッド	ROD	1
8	252609-920	クランク	CRANK	1
9	0045310	六角穴ボルト/M5×12	BOLT	1
10	2400550	座金	WASHER	1
11	0070410	皿ネジ/M3×6	SCREW	1
12	2526120	ロッド	ROD	1
13	2526140	リンク	LINK	1
14	2526150	リンク	LINK	1
15	0045370	止ネジ/M4×5	SCREW	2
16	2526130	平行ピン	PIN	2
17	2021760	給油紐	OIL STRING	2
18	2073580	フェルト	FELT	6
19	2526160	平行ピン	PIN	1
20	2021760	給油紐	OIL STRING	1
21	2079250	フェルト	FELT	4
22	2526170	クランク	CRANK	1
23	0071420	止ネジ/M6×6	SCREW	2
24	252618-910	リンク	LINK	1
25	0045470	止ネジ/M6×5	SCREW	2
26	2526220	案内	GUIDE	1
27	0045390	止ネジ/M5×6	SCREW	1
28	2526200	引張りバネ	SPRING	1
29	0071310	段ネジ/M5	SCREW	1
30	2526210	軸	SHAFT	1
31	2400170	Oリング	O RING	1
32	2526230	レバー	LEVER	1
33	0070340	平ネジ/M5×10	SCREW	1
34	252624-TB0	目盛板	INDICATION PLATE	1
35	0070440	皿ネジ/M4×10	SCREW	2
36	2526250	調節ネジ	SCREW	1
37	2016290	止メ輪	RING	1
38	2009830	止メ輪	RING	1
39	2402510	Oリング	O RING	1
40	0045500	止ネジ/M4×10	SCREW	1
41	0045370	止ネジ/M4×5	SCREW	1
42	2526260	ライナー	LINER	1
43	2526600	丸ナット	NUT	1
44	2526710	シール	SEAL	1

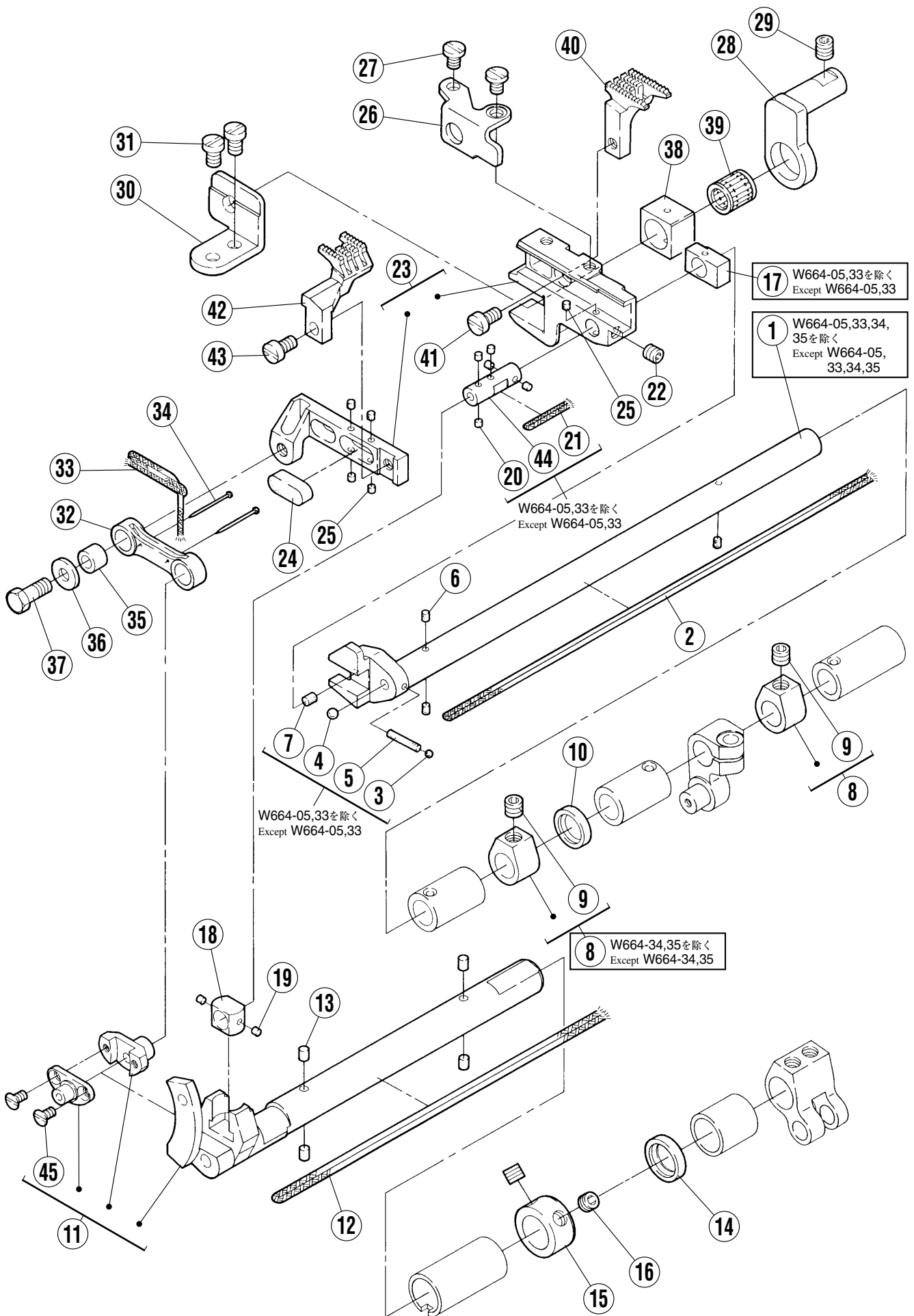

## 送り機構(2)

## FEED MECHANISM(2)

REF.NO.	PART NO.	部品名称	DESCRIPTION	QT.
1	2526100	クランク軸	CRANKSHAFT	1
2	2021750	給油紐	OIL STRING	1
3	2401480	栓	PLUG	1
4	2400970	栓	PLUG	1
5	179320-050	フェルト	FELT	1
6	2073580	フェルト	FELT	3
7	2067480	フェルト	FELT	1
8	240235-920	カラー	COLLAR	
9	0045470	止ネジ/M6×5	SCREW	
10	204052A0	オイルシール	OIL SEAL	1
11	252633-910	クランク軸	CRANKSHAFT	1
12	2021770	給油紐	OIL STRING	1
13	2067480	フェルト	FELT	4
14	2402410	オイルシール	OIL SEAL	1
15	2402390	カラー	COLLAR	1
16	0071280	止ネジ/M6×4	SCREW	2
17	2526750	角駒	BLOCK	1
18	2526310	角駒	BLOCK	1
19	2079250	フェルト	FELT	2
20	2079250	フェルト	FELT	5
21	2021760	給油紐	OIL STRING	1
22	0045140	止ネジ/M5×5	SCREW	1
23	252659-910	送り台(組)	FEED BAR ASSEMBLY	1
24	2402400	フェルト	FELT	1
25	2079250	フェルト	FELT	5
26	2526390	案内/差動送り台	DIFFERENTIAL FEED BAR GUIDE	1
27	0071430	平ネジ/M4×5.5	SCREW	2
28	2526280	案内(右)	GUIDE (RIGHT)	1
29	0045220	止ネジ/M6×6	SCREW	1
30	2526290	案内(左)	GUIDE (LEFT)	1
31	0071300	平ネジ/M4×7	SCREW	2
32	2526360	リンク	LINK	1
33	2021750	給油紐	OIL STRING	1
34	2107660	止ピン	PIN	2
35	2526370	ブッシュ	BUSHING	1
36	2400390	座金	WASHER	1
37	0070560	六角ネジ/M5×13	SCREW	1
38	2526320	角駒	BLOCK	1
39	210238-20	ニードルベアリング	NEEDLE BEARING	1
40	XXXXXX	主送り歯	MAIN FEED DOG	1
41	0070190	平ネジ/M4×8	SCREW	1
42	XXXXXX	差動送り歯	DIFF. FEED DOG	1
43	0070190	平ネジ/M4×8	SCREW	1
44	252630-C0	平行ピン	PIN	1
45	0070410	皿ネジ/M3×6	SCREW	2

●XXXXXXはゲージパーツです。  
部品番号は88～92頁のゲージパーツ表を  
参照してください。

●"XXXXXX" represents the gauge part.  
Please refer to the gauge part list (page 88-92).

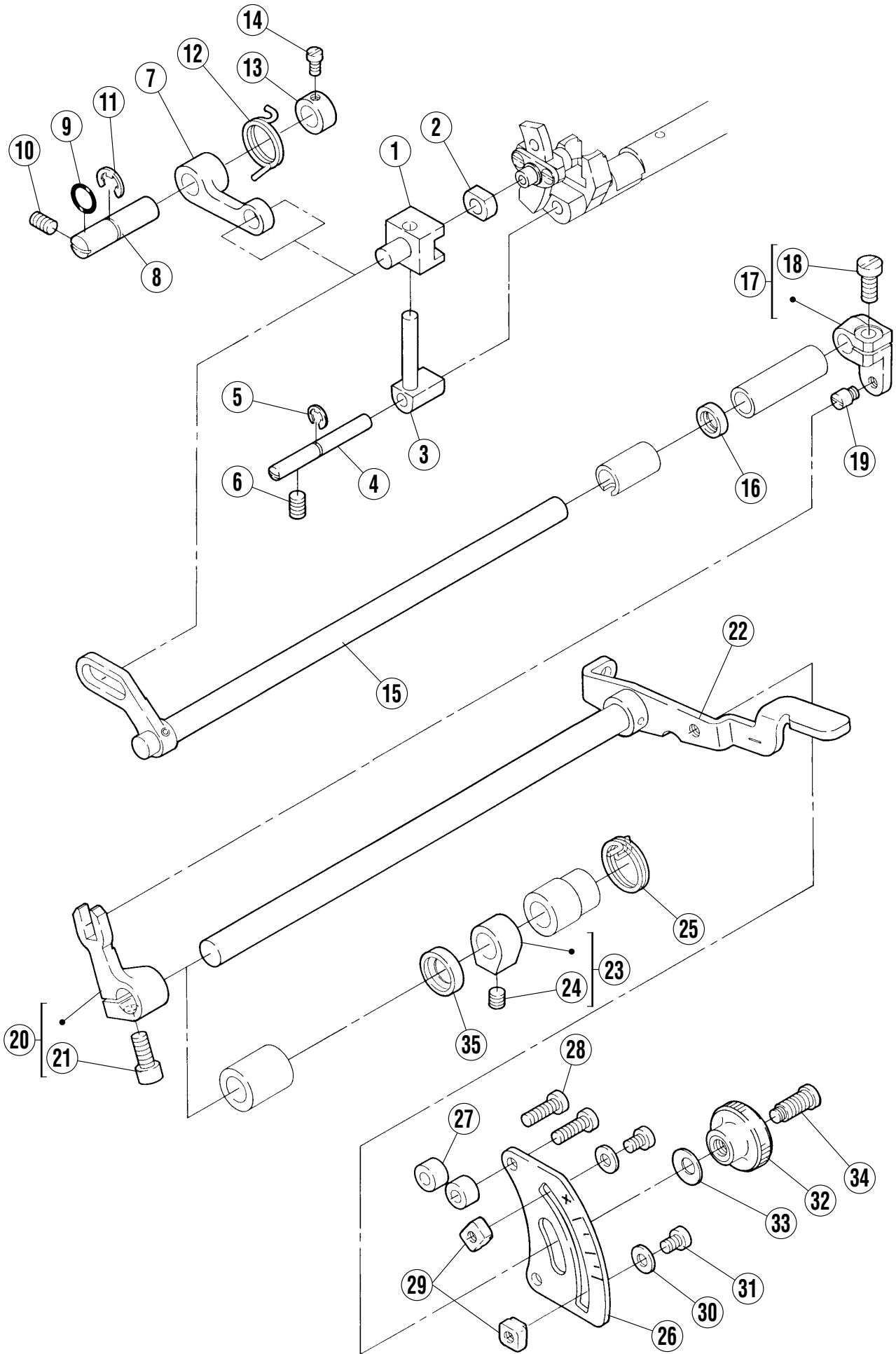

## 送り機構(3)

## FEED MECHANISM(3)

REF.NO.	PART NO.	部品名称	DESCRIPTION	QT.
1	2526410	角駒	BLOCK	1
2	2526420	案内	GUIDE	1
3	2526430	案内軸	FEED BAR PIN	1
4	2526650	軸	SHAFT	1
5	2016290	止メ輪	RING	1
6	0045400	止ネジ/M5×8	SCREW	1
7	2526440	レバー	LEVER	1
8	2526460	軸	SHAFT	1
9	2401290	Oリング	O RING	1
10	0045400	止ネジ/M5×8	SCREW	1
11	2025220	止メ輪	RING	1
12	2526450	ネジリバネ	SPRING	1
13	2325080	カラー	COLLAR	1
14	001998-20	平ネジ/C4×6	SCREW	1
15	252648-910	レバー軸	LEVER SHAFT ASSEMBLY	1
16	2069420	オイルシール	OIL SEAL	1
17	252651-920	クランク	CRANK	1
18	0070290	平ネジ/M5×12	SCREW	1
19	0071320	ピン付ネジ/M4	SCREW	1
20	252652-920	レバー	LEVER	1
21	0045310	六角穴ボルト/M5×12	BOLT	1
22	252653-910	レバー軸	LEVER SHAFT ASSEMBLY	1
23	240235-920	カラー	COLLAR	1
24	0045470	止ネジ/M6×5	SCREW	1
25	2526570	線細工バネ	SPRING	1
26	2526560	目盛板	SCALE PLATE	1
27	2401240	スペーサー	SPACER	2
28	007022A0	平ネジ/M4 X 14	SCREW	2
29	2526580	ストッパー	STOPPER	2
30	3034480	座金	WASHER	2
31	007018A0	平ネジ/M4×6	SCREW	2
32	2520690	ナット	NUT	1
33	2113010	バネ座金	SPRING WASHER	1
34	0070590	段付ネジ/M4.5	SCREW	1
35	2400630	オイルシール	OIL SEAL	1

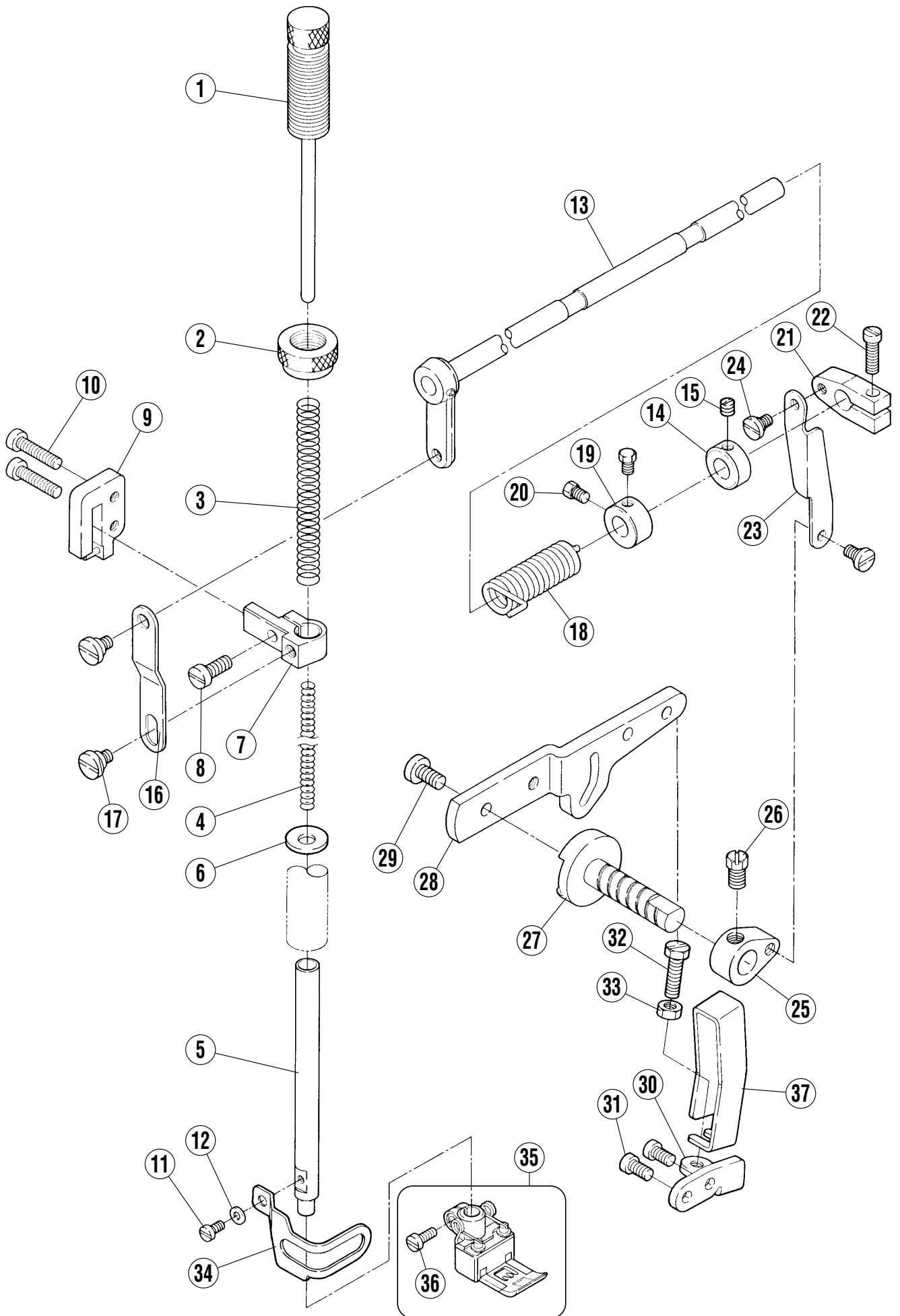



押エ機構

PRESSER FOOT MECHANISM

REF.NO.	PART NO.	部品名称	DESCRIPTION	QT.
1	253000-910	調節棒	ADJUSTING BAR	1
2	2530031	調節ナット	NUT	1
3	2402520	圧縮バネ	SPRING	1
4	2402530	圧縮バネ	SPRING	1
5	2530260	押エ棒	PRESSER BAR	1
6	2530180	油除ケ	OIL SHIELD	1
7	2061390	押エ棒抱キ	PRESSER BAR CLAMP	1
8	0051180	平ネジ/C5×12	SCREW	1
9	253005-910	案内	GUIDE	1
10	007025A0	平ネジ/M4×20	SCREW	2
11	0070100	平ネジ/M3×6	SCREW	1
12	2404740	座金	WASHER	1
13	253008-910	レバー	LEVER	1
14	1920240	カラー	COLLAR	1
15	0W00024-10	止ネジ/W2×4	SCREW	1
16	2061570	リンク	LINK	1
17	0053860	段付ネジ/C7	SCREW	2
18	2530100	ネジリバネ	SPRING	1
19	2061560	カラー	COLLAR	1
20	0050840	六角ネジ/C5 X 5.5	SCREW	2
21	2061490	クランク (上)	BELL CRANK (UPPER)	1
22	0051870	平ネジ/C5×14	SCREW	1
23	2530270	リンク	LINK	1
24	0051840	段付ネジ/C5	SCREW	1
25	2061480	クランク (下)	BELL CRANK (LOWER)	1
26	002022-40	六角ネジ/C10×9	SCREW	1
27	2530130	軸	SHAFT	1
28	2530140	レバー	LEVER	1
29	0070340	平ネジ/M5×10	SCREW	1
30	2530150	ブラケット	BRACKET	1
31	007019A0	平ネジ/M4×8	SCREW	2
32	0045810	六角ネジ/M5×20	SCREW	1
33	0048050	六角ナット/M5	NUT	1
34	2530280	フィンガーガード	FINGER GUARD	1
35	XXXXXX	押エ	PRESSER FOOT ASSEMBLY	1
36	001170-30	平ネジ/C4×9	SCREW	1
37	250230-RA0	押エ上ゲレバーガード	GUARD (PRESSER FOOT LIFT LEVER)	1

●XXXXXXはゲージパーツです。  
部品番号は88～92頁のゲージパーツ表を  
参照してください。

●"XXXXXX" represents the gauge part.  
Please refer to the gauge part list (page 88-92).

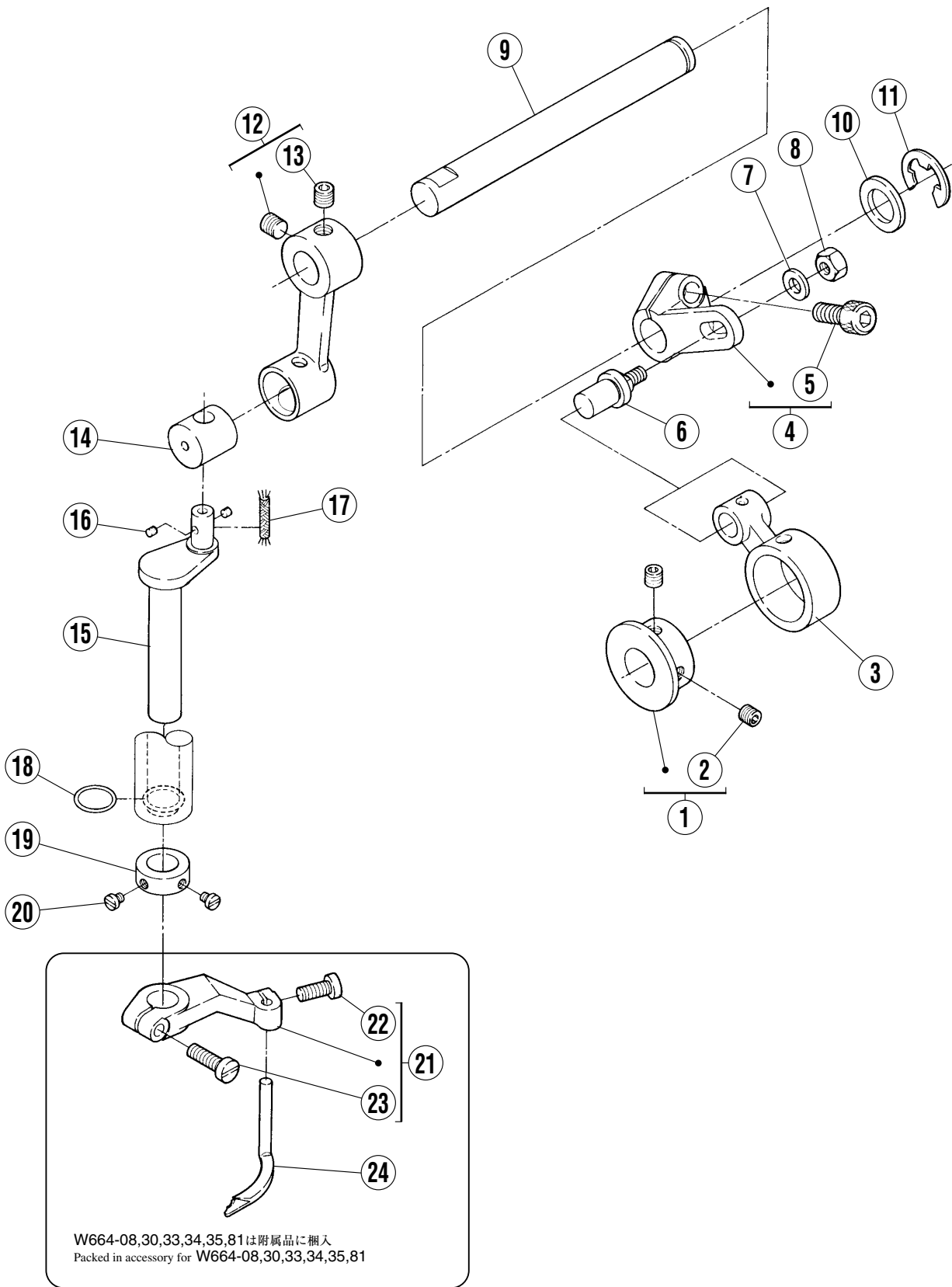

飾り振り機構

SPREADER MECHANISM

REF.NO.	PART NO.	部品名称	DESCRIPTION	QT.
1	254501A920	エキセン (組)	ECCENTRIC ASSEMBLY	1
2	0045140	止ネジ/M5×5	SCREW	2
3	2545110	ロッド	CONNECTION	1
4	254503-920	クランク	CRANK	1
5	0045340	六角穴ボルト/M6×14	BOLT	1
6	2545040	ピン付ネジ/M5	SCREW	1
7	2400620	座金	WASHER	1
8	0048050	六角ナット/M5	NUT	1
9	2545190	軸	SHAFT	1
10	2061800	座金	WASHER	1
11	3066710	止メ輪	RING	1
12	254506B0	クランク	CRANK	1
13	0045470	止ネジ/M6×5	SCREW	2
14	2545070	駒	BLOCK	1
15	2545180	クランク軸	CRANKSHAFT	1
16	2079250	フェルト	FELT	2
17	2021760	給油紐	OIL STRING	1
18	2330200	Oリング	O RING	1
19	2120390	カラー	COLLAR	1
20	0012270	平ネジ/C×3.7	SCREW	2
21	254516-920	レバー (組)	LEVER ASSEMBLY	1
22	0070200	平ネジ/M4×10	SCREW	1
23	0070220	平ネジ/M4×14	SCREW	1
24	2575650	スプレッダー	SPREADER	1

**13** 2本針 上飾り: 有り  
2-Needle. With top cover thread.

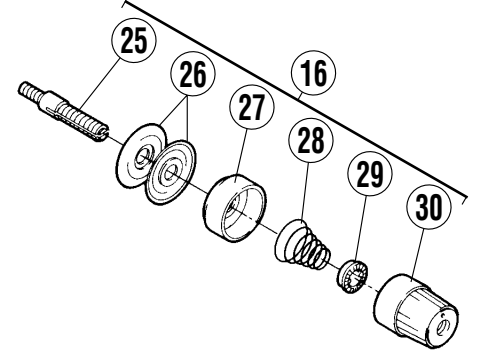
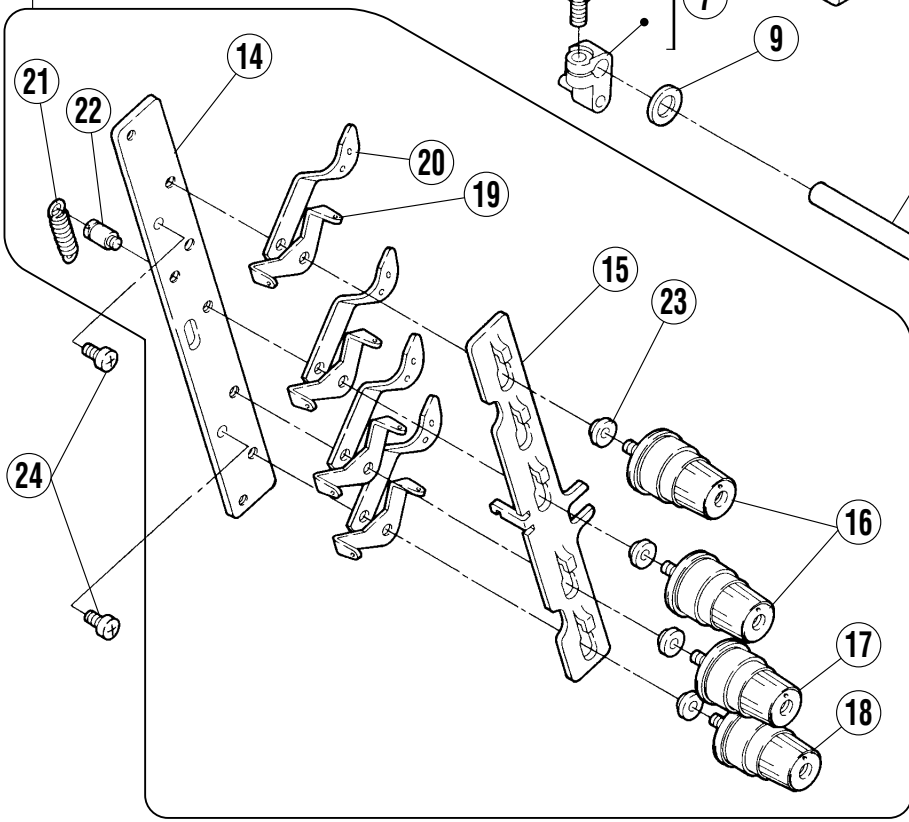

**33** 3本針 上飾り: 有り  
3-Needle. With top cover thread.

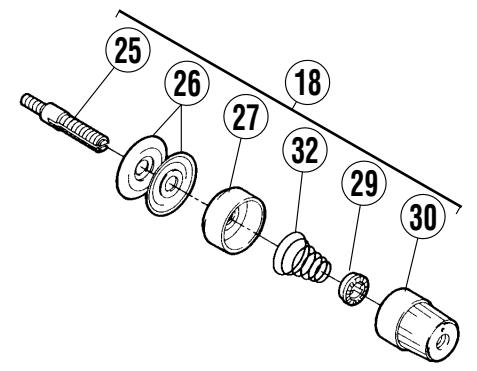
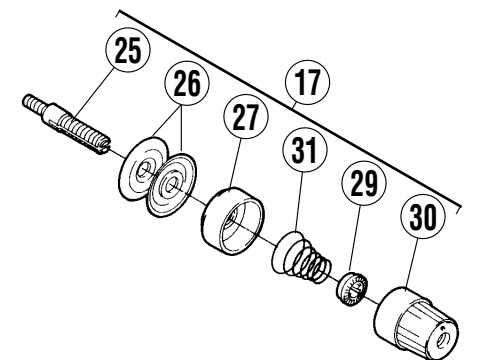
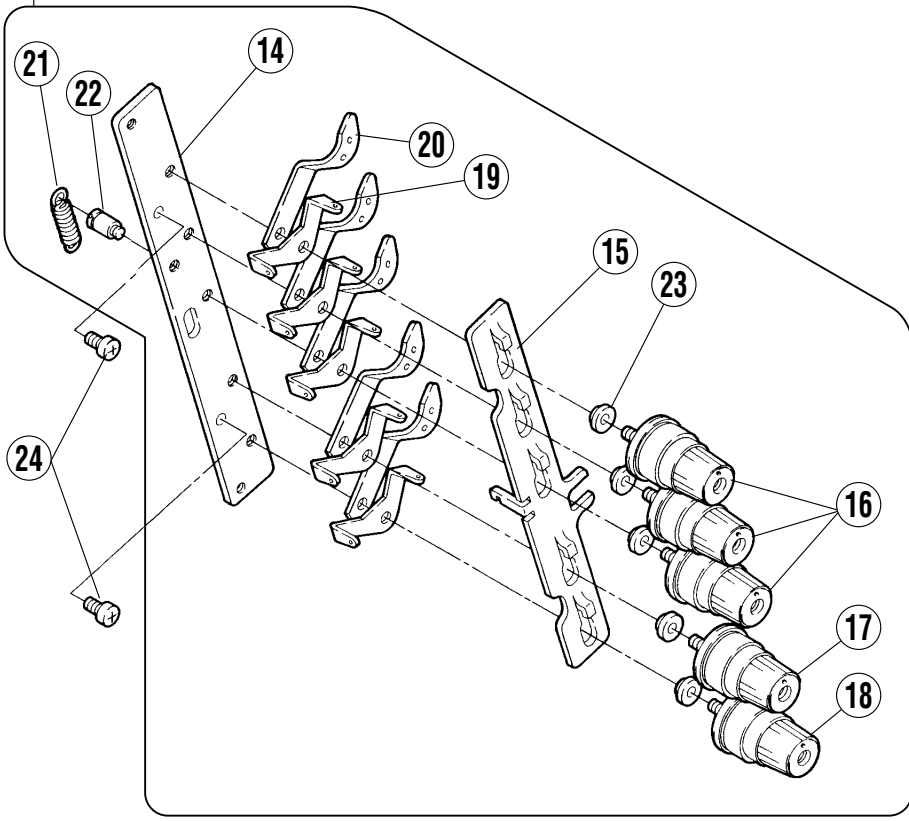

## 糸調子機構

## THREAD TENSION MECHANISM

REF.NO.	PART NO.	部品名称	DESCRIPTION	QT.
1	2540080	糸道	THREAD GUIDE	1
2	007019A0	平ネジ/M4×8	SCREW	2
3	1921200	パイプ	PIPE	2
4	2061150	ホルダー	HOLDER	2
5	007018A0	平ネジ/M4×6	SCREW	1
6	3034480	座金	WASHER	1
7	254003B910	クランク	CRANK	1
8	0045310	六角穴ボルト/M5×12	BOLT	1
9	2028680	座金	WASHER	1
10	254000-910	レバー	LEVER	1
11	2540220	カラー	COLLAR	1
12	002133-10	平ネジ/C5×12.5	SCREW	1
13	254023C9T0	テンション (組)	TENSION CONTROL MECHANISM	1
14	2540190	ブラケット	BRACKET	1
15	2540210	糸緩め	THREAD RELEASER	1
16	263542A9T0	糸調子 (組) (強)	TENSION SPRING ASSEMBLY (HEAVY)	
17	263542B9T0	糸調子 (組)	TENSION SPRING ASSEMBLY	1
18	263542C9T0	糸調子 (組) (弱)	TENSION SPRING ASSEMBLY (LIGHT)	1
19	2540200	糸道	THREAD GUIDE	
20	2062030	糸道	THREAD GUIDE	
21	3063010	引張りバネ	SPRING	1
22	0054470	段付ネジ/C5	SCREW	1
23	2062020	スペーサー	SPACER	
24	007019A0	平ネジ/M4×8	SCREW	2
25	001817-2A0	調子棒	SCREW STUD	1
26	2103190	調子皿	TENSION DISC	2
27	263544-TA0	受皿	CUP	1
28	2010370	圧縮バネ (強)	SPRING (HEAVY)	1
29	2084480	ラチェット	RATCHET	1
30	263543-TA0	調子ナット	NUT	1
31	2010860	圧縮バネ (中)	SPRING (MEDIUM)	1
32	2010680	圧縮バネ (弱)	SPRING (LIGHT)	1
33	254023E9T0	テンション (組)	TENSION CONTROL MECHANISM	1

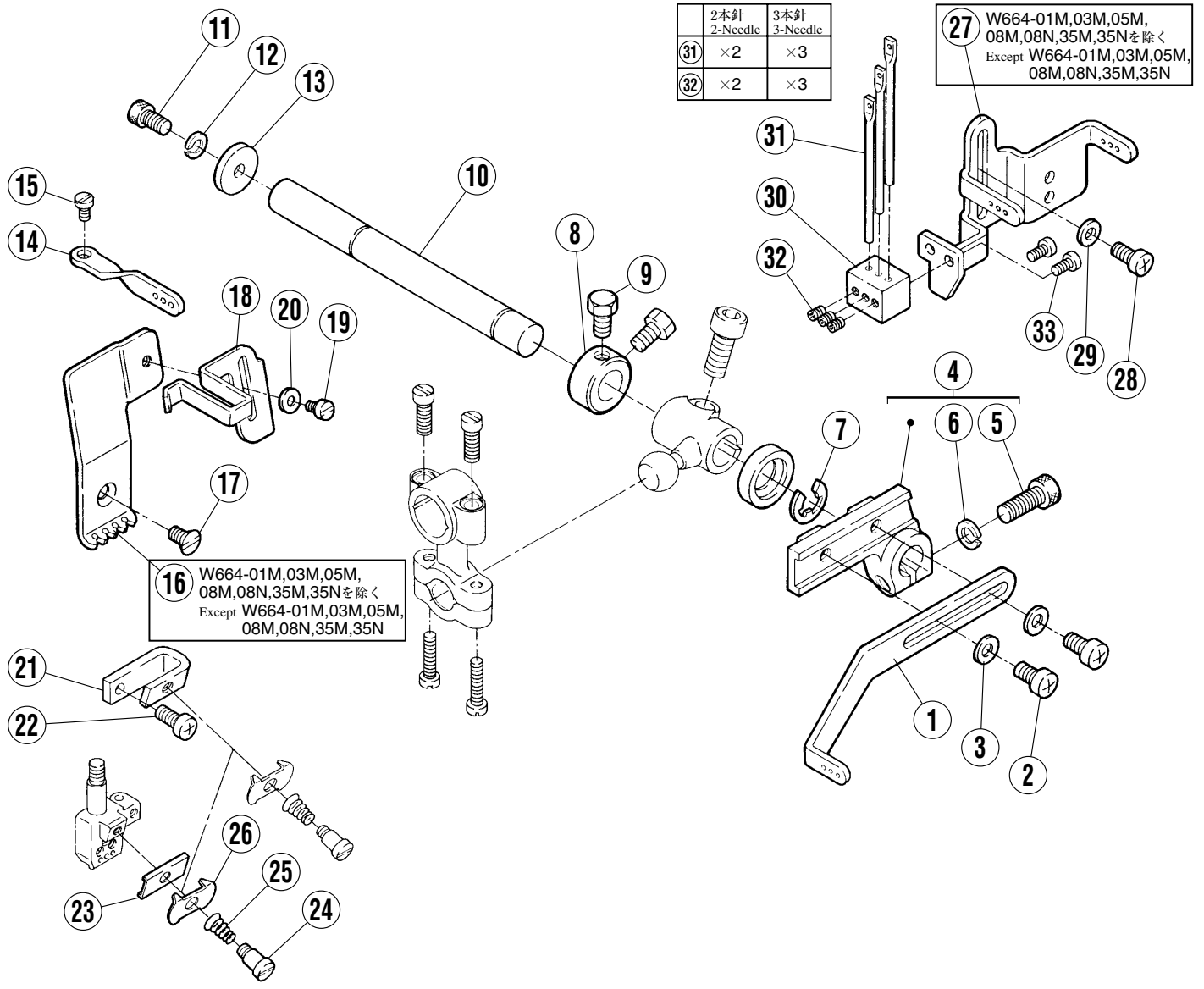

	2本針 2-Needle	3本針 3-Needle
31	×2	×3
32	×2	×3

27 W664-01M,03M,05M,  
08M,08N,35M,35Nを除く  
Except W664-01M,03M,05M,  
08M,08N,35M,35N

16 W664-01M,03M,05M,  
08M,08N,35M,35Nを除く  
Except W664-01M,03M,05M,  
08M,08N,35M,35N

W664-08,30,33,34,35,81は附属品  
Packed in accessory for W664-08,30,33,34,35,81

47 W664-01G,03L,30,32,33,34,35,81を除く  
Except W664-01G,03L,30,32,33,34,35,81

50 W664-01C,01E,02,03F,03G,03K,05,08,71を除く  
Except W664-01C,01E,02,03F,03G,03K,05,08,71

## 針糸・飾り糸機構

## NEEDLE &amp; SPREADER THREAD HANDLING

REF.NO.	PART NO.	部品名称	DESCRIPTION	QT.
1	253505A1	糸繰り	THREAD TAKE-UP	1
2	007019A0	平ネジ/M4×8	SCREW	2
3	3034480	座金	WASHER	2
4	253504-920	レバー	LEVER	1
5	0045010	六角穴ボルト/M5×14	BOLT	1
6	3030670	バネ座金	SPRING WASHER	1
7	2050610	止メ輪	RING	1
8	204754A0	カラー	COLLAR	1
9	0021930	六角ネジ/C5×8.5	SCREW	2
10	2535030	軸	SHAFT	1
11	0045270	六角穴ボルト/M4×8	BOLT	1
12	2012520	バネ座金	SPRING WASHER	1
13	2041070	座金	WASHER	1
14	2535070	糸道	THREAD GUIDE	1
15	0070090	平ネジ/M3×5	SCREW	1
16	253508A0	糸道	THREAD GUIDE	1
17	0070770	皿ネジ/M4×7	SCREW	1
18	253509A0	糸受	THREAD SUPPORT	1
19	0070080	平ネジ/M3×4	SCREW	1
20	2404740	座金	WASHER	1
21	2535160	糸調子台	THREAD TENSION BRACKET	1
22	007019A0	平ネジ/M4×8	SCREW	1
23	2345610	糸案内	THREAD GUIDE	1
24	0W09070-20	段付ネジ/W5	SCREW	1
25	2535170	調子バネ	SPRING	1
26	2535930	小調子皿	TENSION DISC	1
27	2535440	糸道	THREAD GUIDE	1
28	007019A0	平ネジ/M4×8	SCREW	1
29	3034480	座金	WASHER	1
30	2535450	ホルダー	HOLDER	1
31	2345210	糸道	THREAD GUIDE	
32	0045350	止ネジ/M3×4	SCREW	
33	0070100	平ネジ/M3×6	SCREW	2
34	2535060	糸繰り	THREAD TAKE-UP	1
35	2535140	糸道	THREAD GUIDE	1
36	007019A0	平ネジ/M4×8	SCREW	2
37	2535150	糸道	THREAD GUIDE	1
38	007019A0	平ネジ/M4×8	SCREW	1
39	253548B0	糸案内	THREAD GUIDE	1
40	0070190	平ネジ/M4×8	SCREW	2
41	3034480	座金	WASHER	2
42	2535470	糸道	THREAD GUIDE	1
43	1371080	調子皿	TENSION DISC	2
44	2113880	圧縮バネ	SPRING	1
45	0071671	段付ネジ/C3	SCREW	1
46	2750340	ツマミ	KNOB	1
47	2535110	糸道	THREAD GUIDE	1
48	0045540	止ネジ/M3×3	SCREW	1
49	2502290	糸繰りレバーガード	GUARD (THREAD TAKE-UP LEVER)	1
50	2536680	糸道	THREAD GUIDE	1

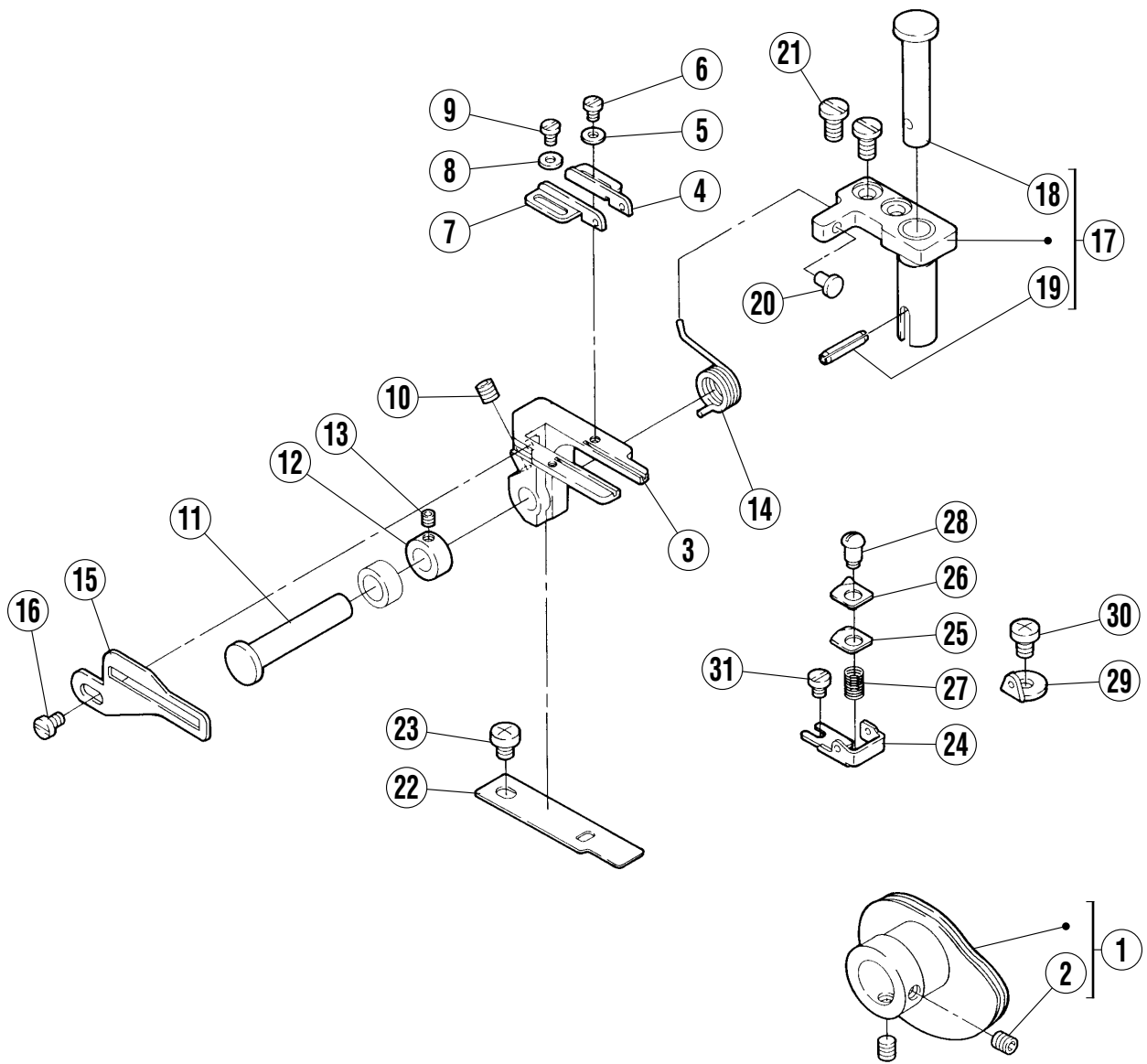



下糸繰り機構

LOOPER THREAD HANDLING

REF.NO.	PART NO.	部品名称	DESCRIPTION	QT.
1	253693-910	下糸繰り	LOOPER THREAD TAKE-UP	1
2	0045370	止ネジ/M4×5	SCREW	2
3	2535920	下糸繰り台	BRACKET (LOOPER THREAD TAKE-UP)	1
4	253534A0	糸道	THREAD GUIDE	1
5	2105850	座金	WASHER	1
6	0070310	平ネジ/M2.5×4	SCREW	1
7	253533D0	糸道	THREAD GUIDE	1
8	2105850	座金	WASHER	1
9	0070310	平ネジ/M2.5×4	SCREW	1
10	0045430	止ネジ/M4×4	SCREW	1
11	2536000	軸	SHAFT	1
12	2402610	カラー	COLLAR	1
13	0045540	止ネジ/M4×4	SCREW	1
14	253606A0	ネジリバネ	SPRING	1
15	2536800	糸案内	THREAD GUIDE	1
16	0070090	平ネジ/M3×5	SCREW	1
17	253607-910	ブラケット (組)	BRACKET ASSEMBLY	1
18	2536010	軸	SHAFT	1
19	202647A0	スプリングピン	SPRING PIN	1
20	2401230	防振ゴム	CUSHION RUBBER	1
21	0070820	平ネジ/M4×8	SCREW	2
22	2536050	板バネ	FLAT SPRING	1
23	007017A0	平ネジ/M4×5	SCREW	1
24	2535860	糸道	THREAD GUIDE	1
25	253588A0	小調子皿	TENSION DISC	1
26	2535880	小調子皿	TENSION DISC	1
27	2402420	圧縮バネ	SPRING	1
28	0071330	段付ネジ/M3	SCREW	1
29	1670790	糸道	THREAD GUIDE	1
30	007018A0	平ネジ/M4×6	SCREW	1
31	0070080	平ネジ/M3×4	SCREW	1

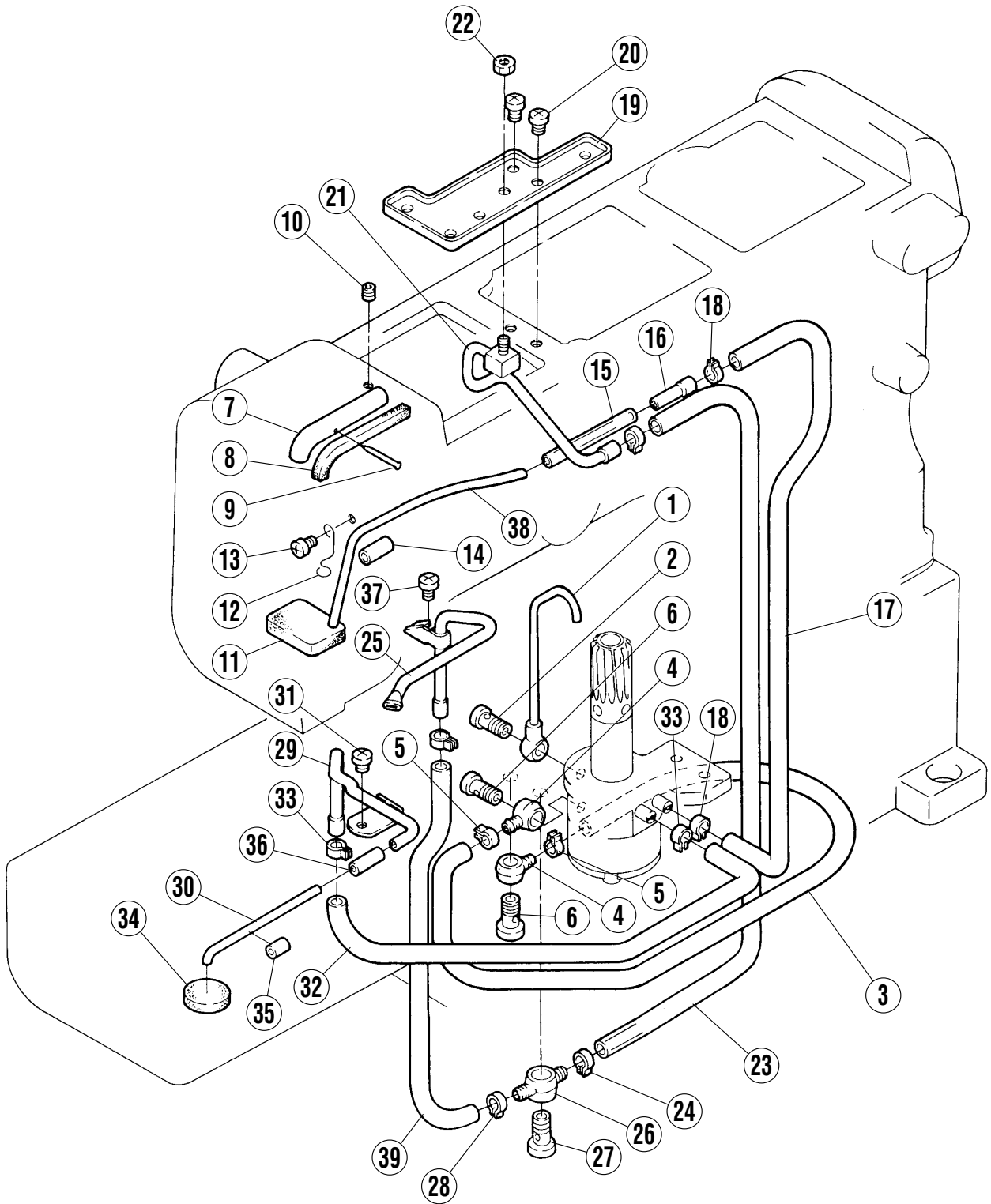

## 給油機構(1)

## LUBRICATION MECHANISM(1)

REF.NO.	PART NO.	部品名称	DESCRIPTION	QT.
1	255035-910	パイプ	PIPE	1
2	2550370	継手ネジ	JOINT SCREW	1
3	2401350	チューブ	TUBE	1
4	2001360	継手	JOINT	2
5	2021990	クランプ	CLAMP	2
6	2001520	継手ネジ	JOINT SCREW	2
7	2550030	パイプ	PIPE	1
8	2401360	フェルト	FELT	1
9	2107660	止ピン	PIN	1
10	0045140	止ネジ/M5×5	SCREW	1
11	2550210	フェルト	FELT	1
12	2550050	ラッチ	LATCH	1
13	007018A0	平ネジ/M4×6	SCREW	1
14	2401430	チューブ	TUBE	1
15	2405680	チューブ	TUBE	1
16	2550380	継手	JOINT	1
17	2401450	チューブ	TUBE	1
18	2021990	クランプ	CLAMP	2
19	2550990	油受ケ	OIL RELEASE PLATE	1
20	007018A0	平ネジ/M4×6	SCREW	2
21	255097-910	噴油管	OIL SPLASH PIPE	1
22	0048210	六角ナット/M4	NUT	1
23	2400060	チューブ	TUBE	1
24	2021990	クランプ	CLAMP	2
25	255094-910	噴油管	OIL SPLASH PIPE	1
26	2551230	継手	JOINT	1
27	2001520	継手ネジ	JOINT SCREW	1
28	2021990	クランプ	CLAMP	1
29	255100-910	排油管	OIL DRAIN PIPE	1
30	2551020	パイプ	PIPE	1
31	007017A0	平ネジ/M4×5	SCREW	1
32	2068400	チューブ	TUBE	1
33	2021990	クランプ	CLAMP	2
34	2402450	フェルト	FELT	1
35	2402440	チューブ	TUBE	1
36	2401430	チューブ	TUBE	1
37	007018A0	平ネジ/M4×6	SCREW	1
38	2550390	パイプ	PIPE	1
39	200140A0	給油パイプ	OIL TUBE	1

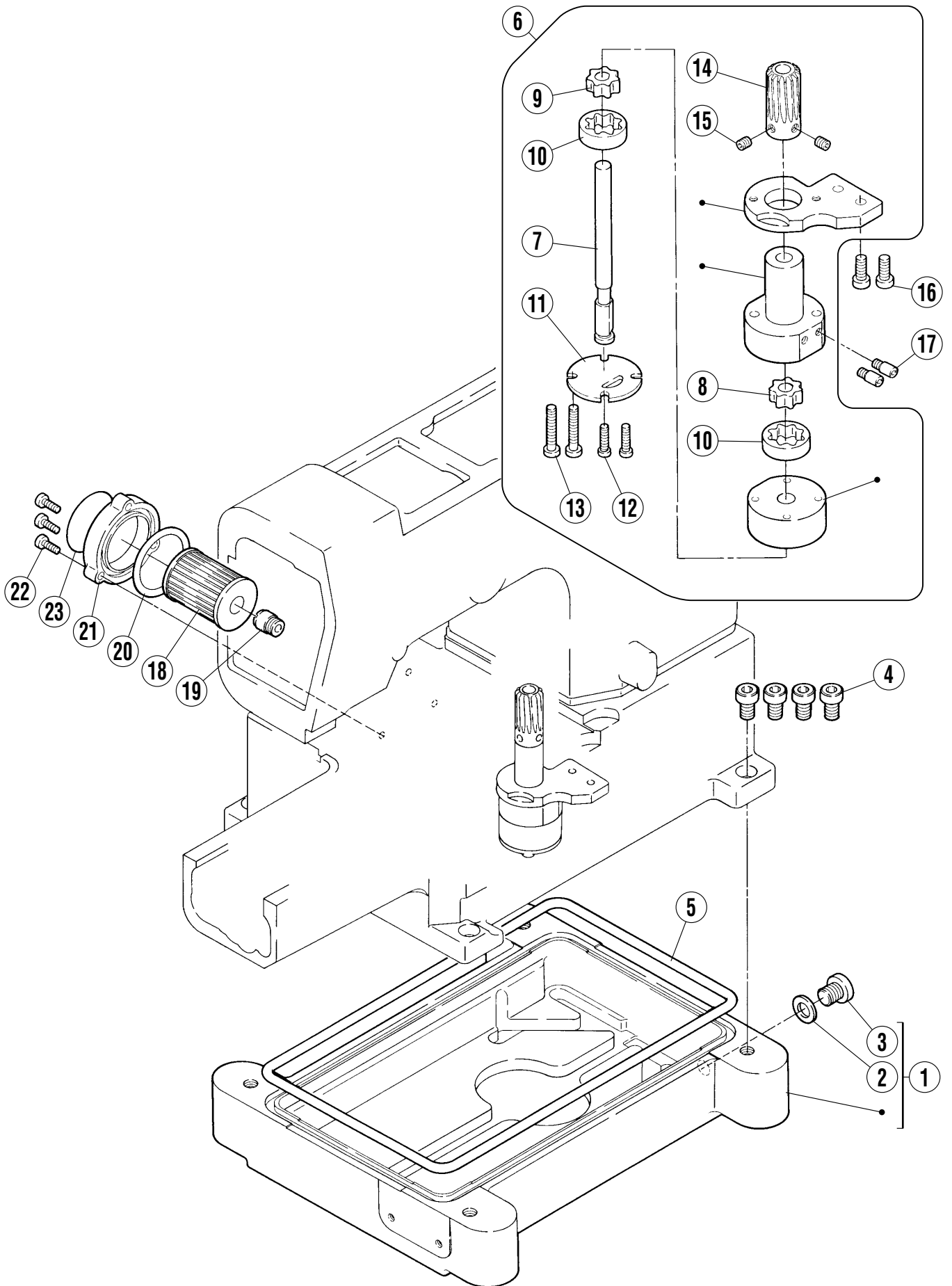

## 給油機構(2)

## LUBRICATION MECHANISM(2)

REF.NO.	PART NO.	部品名称	DESCRIPTION	QT.
1	2550410	オイルパン (組)	OIL RESERVOIR ASSEMBLY	1
2	202287A0	座金	WASHER	1
3	005138B0	平ネジ/H11×12	SCREW	1
4	0045040	六角穴ボルト/M8×20	BOLT	4
5	2551440	Oリング	O RING	1
6	255091-910	ポンプ (組)	OIL PUMP ASSEMBLY	1
7	2550240	軸	SHAFT	1
8	2550250	ローター	ROTOR	1
9	2550260	ローター	ROTOR	1
10	2550270	ローター	ROTOR	1
11	2550280	カバー	COVER	1
12	0070260	平ネジ/M4×5	SCREW	2
13	0071050	平ネジ/M4×40	SCREW	2
14	2550190	ウォームホイール	WORM WHEEL	1
15	0045140	止ネジ/M5×5	SCREW	2
16	0045310	六角穴ボルト/M5×12	BOLT	2
17	2550930	継手ネジ	JOINT SCREW	2
18	2062330	エレメント	OIL FILTER	1
19	2102000	ブラケット/フィルタ	OIL FILTER BRACKET	1
20	2064310	Oリング	O RING	1
21	210201-PD1	蓋	COVER	1
22	007021A0	平ネジ/M4×12	SCREW	3
23	9A30020	フィルタシール	FILTER SEAL	1

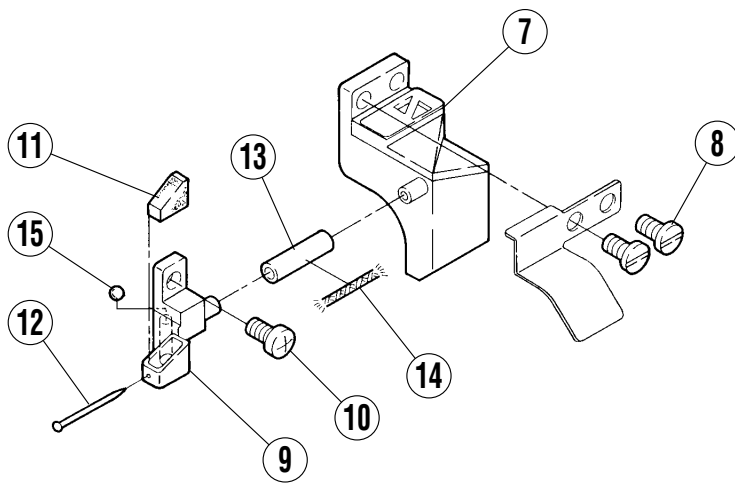
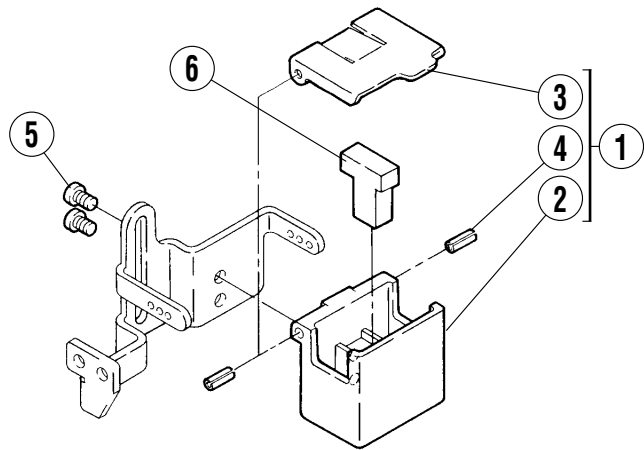

## HR装置

## HR DEVICE

REF.NO.	PART NO.	部品名称	DESCRIPTION	QT.
1	207065-9P0	シリコンタンク上 (組)	SILICONE OIL RESERVOIR (UPPER) ASSEMBLY	1
2	207066-PD0	シリコンタンク (上)	SILICONE OIL RESERVOIR (UPPER)	1
3	207067-PD0	蓋	CAP	1
4	2067810	スプリングピン	SPRING PIN	2
5	0050530	平ネジ/C4×4.8	SCREW	2
6	2070680	フェルト	FELT	1
7	255103-910	シリコンタンク (組)	SILICONE OIL RESERVOIR ASSEMBLY	1
8	0070820	平ネジ/M4×8	SCREW	2
9	2551070	針冷却器 (下)	NEEDLE COOLER (LOWER)	1
10	007019A0	平ネジ/M4×8	SCREW	1
11	2402470	フェルト	FELT	1
12	2107660	止ピン	PIN	1
13	2402460	チューブ	TUBE	1
14	2021750	給油紐	OIL STRING	1
15	2068510	栓	PLUG	1

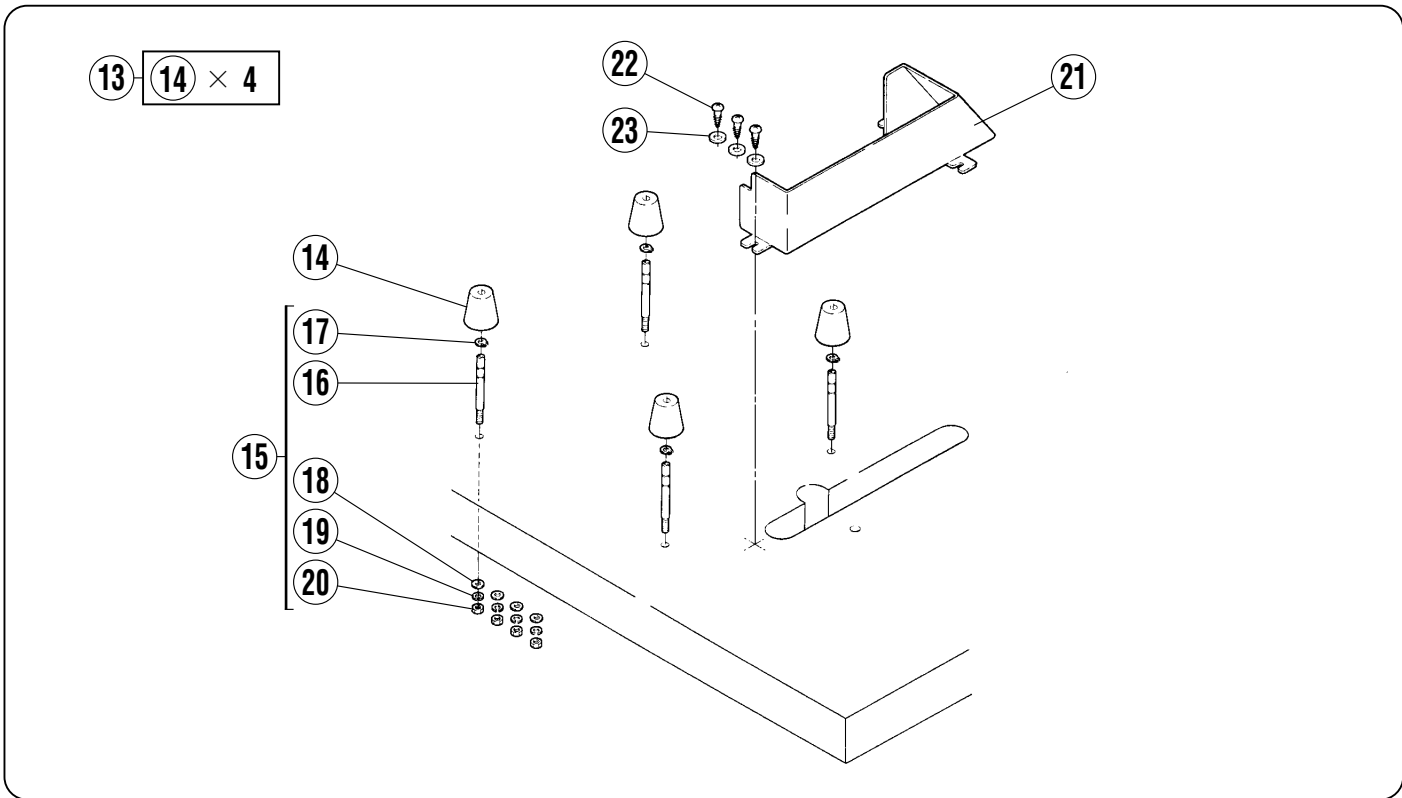
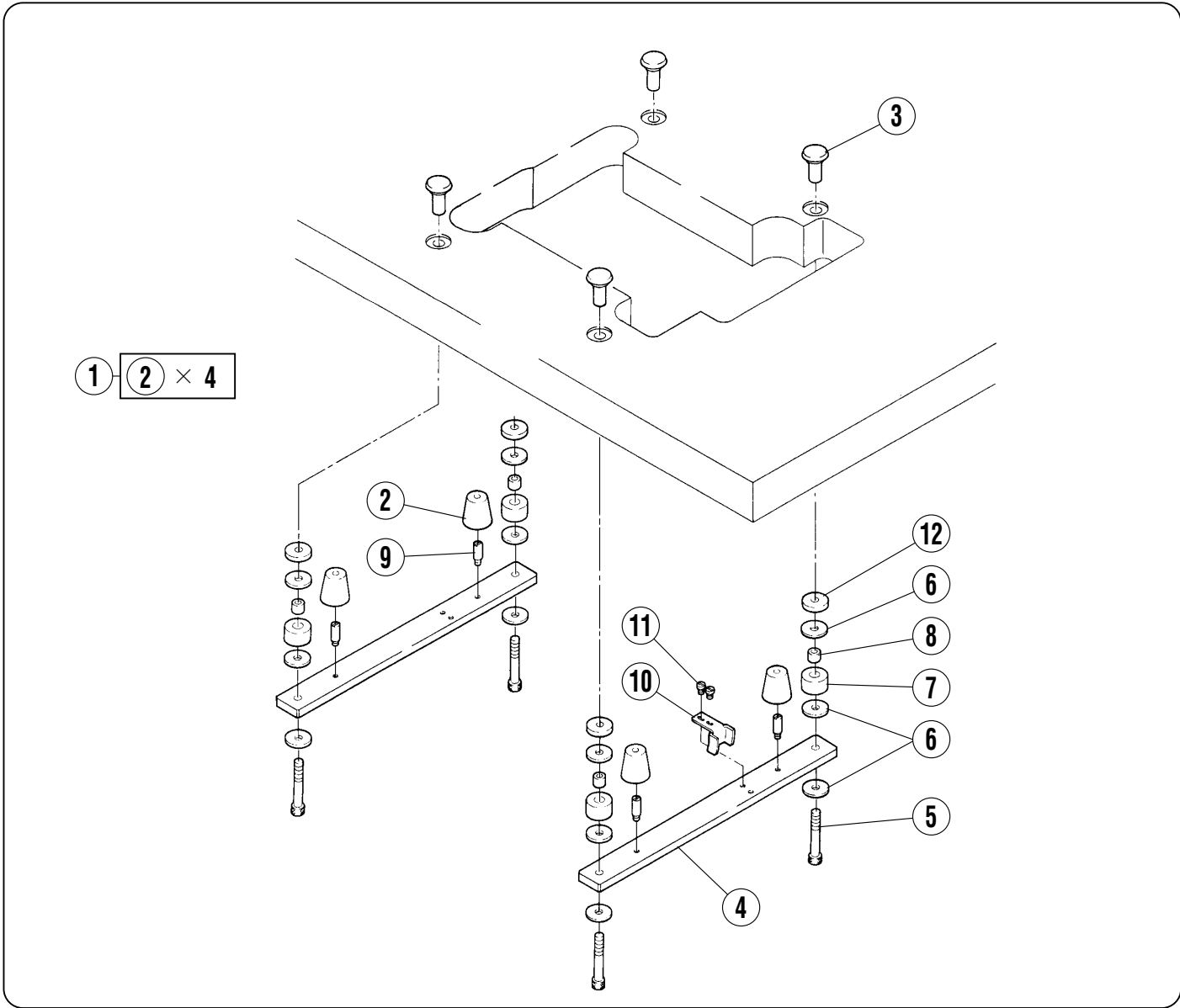



## 据付附属品

## INSTALLATION PARTS

REF.NO.	PART NO.	部品名称	DESCRIPTION	QT.
1	0090160	クッションゴム (セット)	CUSHION RUBBER (SET)	1
2	2063380	クッションゴム	CUSHION RUBBER	4
3	2063360	半沈用ナット/M8	NUT	4
4	2590000	据付台	REST BOARD	2
5	0045120	六角穴ボルト	BOLT	4
6	2063370	座金	WASHER	12
7	2057640	防振ゴム	CUSHION RUBBER	4
8	2057650	ライナー	LINER	4
9	0070930	ピン付ネジ/M5	SCREW	4
10	2063290	鎖案内	TREADLE CHAIN GUIDE	1
11	0070270	平ネジ/M5×8	SCREW	2
12	2054670	スペーサー	SPACER	4
13	0090160	クッションゴム (セット)	CUSHION RUBBER (SET)	1
14	2063380	クッションゴム	CUSHION RUBBER	4
15	0090320	ネジ (セット)	SCREW (SET)	4
16	2070730	段付ネジ/C10	SCREW	4
17	2070740	止メ輪	RING	4
18	2007280	座金	WASHER	4
19	2020450	バネ座金	SPRING WASHER	4
20	0050200	六角ナット/C10	NUT	4
21	259003-TB0	ベルトカバー	BELT COVER	1
22	0049060	木ネジ/4.8	SCREW	3
23	3033350	座金	WASHER	3

- 1 6本立  
6-spool
- 2 5本立  
5-spool

40  
SET UP INSTRUCTIONS  
取付説明書

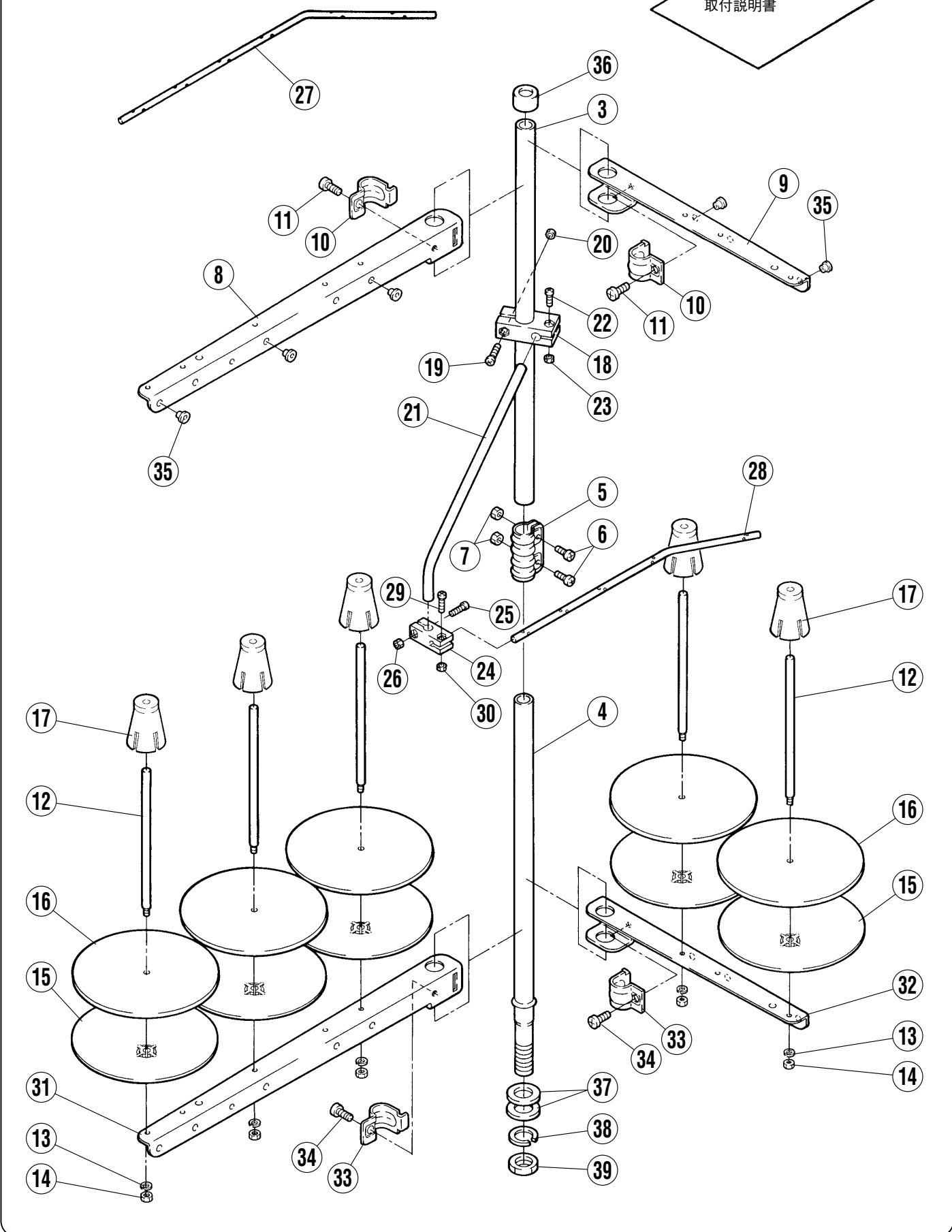

## 糸立台

## THREAD STAND

REF.NO.	PART NO.	部品名称	DESCRIPTION	QT.
1	000100-9P0	糸立て(組) (6本立)	THREAD STAND ASSY. (6-SPOOL)	1
2	000100A9P0	糸立て(組) (5本立)	THREAD STAND ASSY. (5-SPOOL)	1
3	000101-PA0	スタンド棒 (上)	COLUMN PIPE (UPPER)	1 1
4	000102-PA0	スタンド棒 (下)	COLUMN PIPE (LOWER)	1 1
5	0001030	ジョイント	JOINT	1 1
6	004066-HU0	ネジ/M5×14	SCREW	2 2
7	004067-HU0	六角ナット/M5	NUT	2 2
8	000104-PA0	ブラケット (3本立)	BRACKET (3-SPOOL)	1 2
9	000104APA0	ブラケット (2本立)	BRACKET (2-SPOOL)	1
10	0001160	ホルダー	HOLDER	2 2
11	004068-HU0	ネジ/M6×16	SCREW	2 2
12	0001050	糸立棒	SPOOL PIN	5 6
13	303067A0	バネ座金	SPRING WASHER	5 6
14	004067-HU0	六角ナット/M5	NUT	5 6
15	000106-PA0	受皿	SPOOL TRAY	5 6
16	0001070	ウレタン	SPOOL MAT	5 6
17	000108-PA0	揺れ止め	SPOOL RETAINING FIN	5 6
18	000109-PA0	ブラケット	BRACKET	1 1
19	0041130	ネジ/M4×20	SCREW	1 1
20	0048030	六角ナット/M4	NUT	1 1
21	0001100	糸道棒	THREAD GUIDE BAR	1 1
22	004065-HU0	ネジ/M4×12	SCREW	1 1
23	0048030	六角ナット/M4	NUT	1 1
24	000111-PA0	ブラケット	BRACKET	1 1
25	004065-HU0	ネジ/M4×12	SCREW	1 1
26	0048030	六角ナット/M4	NUT	1 1
27	0001120	糸道棒 (6本立)	THREAD GUIDE BAR (6-SPOOL)	1
28	000112A0	糸道棒 (5本立)	THREAD GUIDE BAR (5-SPOOL)	1
29	004065-HU0	ネジ/M4×12	SCREW	1 1
30	0048030	六角ナット/M4	NUT	1 1
31	000104-PA0	ブラケット (3本立)	BRACKET (3-SPOOL)	1 2
32	000104APA0	ブラケット (2本立)	BRACKET (2-SPOOL)	1
33	0001160	ホルダー	HOLDER	2 2
34	004068-HU0	ネジ/M6×16	SCREW	2 2
35	0001130	糸道	THREAD GUIDE	5 6
36	0001140	キャップ	ROD CAP	1 1
37	0001150	座金	WASHER	2 2
38	0001170	バネ座金	SPRING WASHER	1 1
39	007370-HU0	六角ナット/M16	NUT	1 1
40	9A21490	糸立台組立説明書	INSTRUCTIONS	1 1

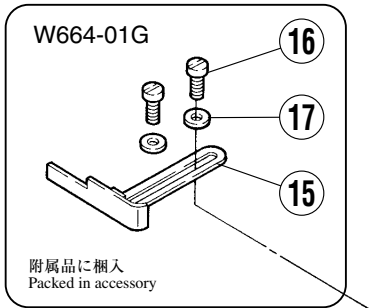
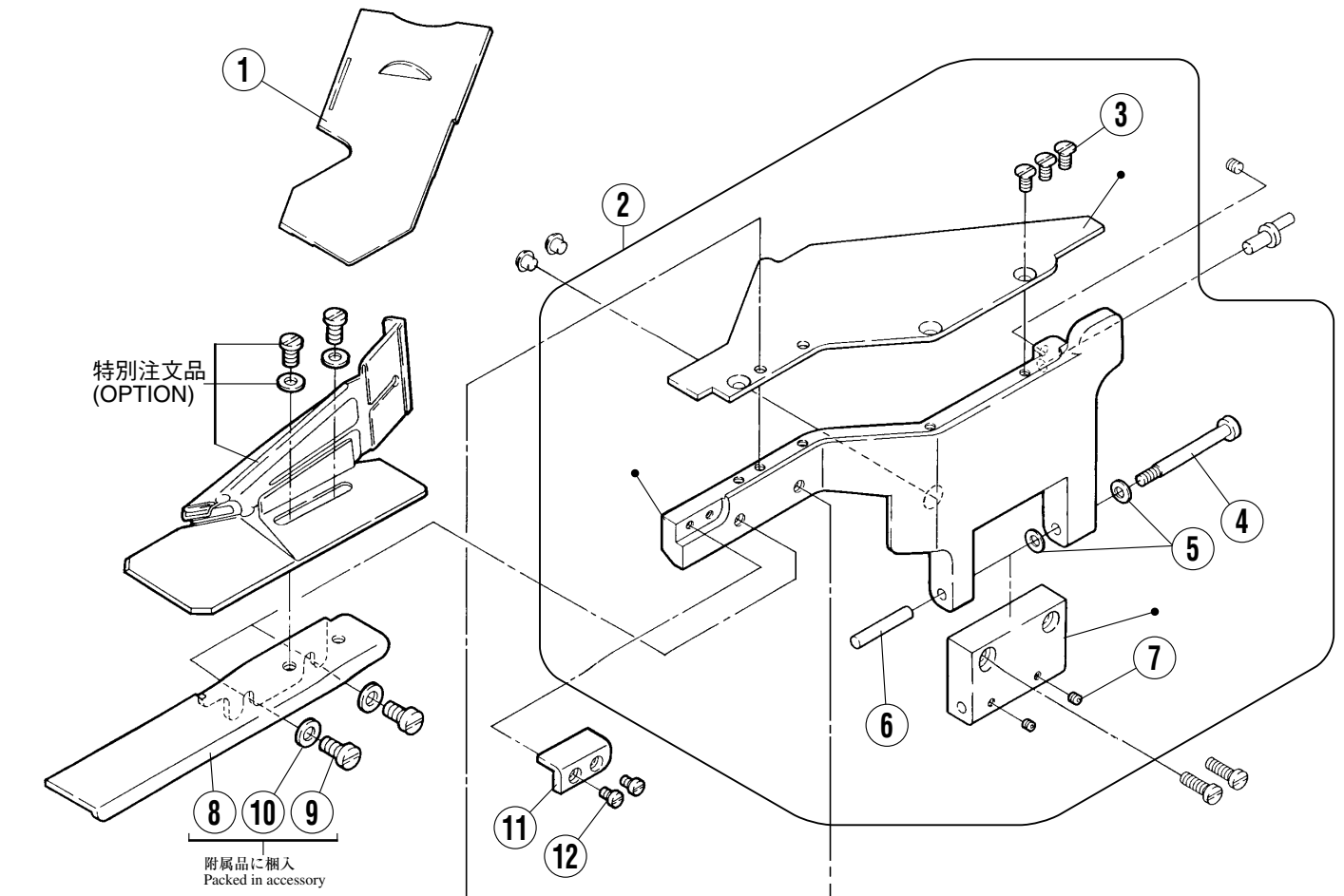

W664-01E,01G

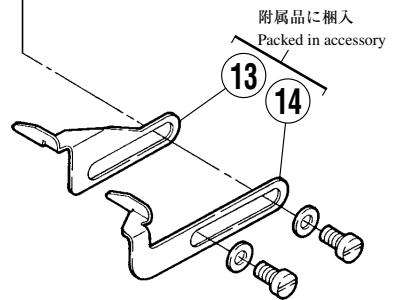
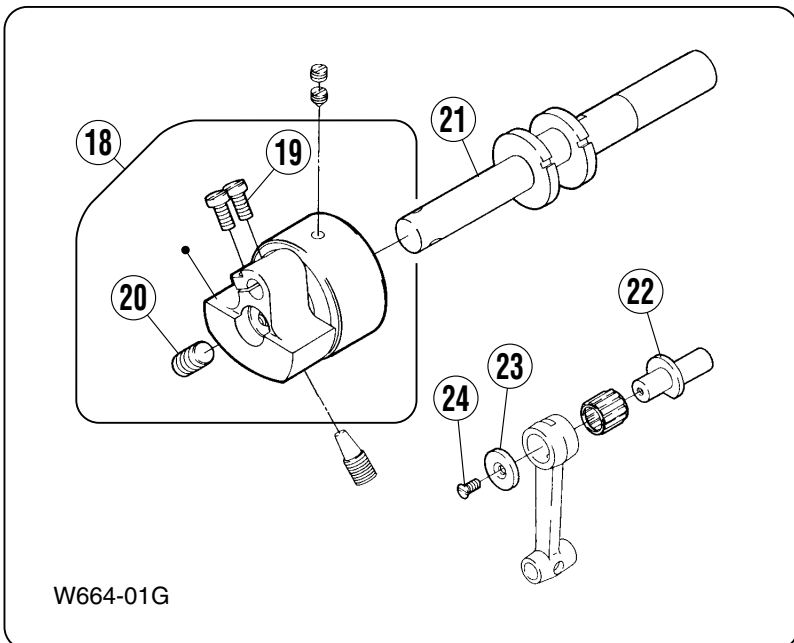

## 専用部品(1)

## SPECIFIC PARTS(1)

REF.NO.	PART NO.	部品名称	DESCRIPTION	QT.
1	2501670	差し板	SLIDE PLATE	1
2	250177BPD1	前カバー (組)	FRONT COVER ASSEMBLY	1
3	0070430	皿ネジ/M4×8	SCREW	3
4	2500130	ピン付ネジ/M4	SCREW	1
5	2011910	バネ座金	SPRING WASHER	2
6	2401980	平行ピン	PIN	1
7	0045540	止ネジ/M3×3	SCREW	2
8	6A005600000	ブラケット (組)	BRACKET ASSEMBLY	1
9	0070280	平ネジ/M5×10	SCREW	2
10	2045850	座金	WASHER	2
11	2502630	ブラケット	BRACKET	1
12	0070090	平ネジ/M3×5	SCREW	2
13	2580100	布案内 (右)	FABRIC GUIDE (RIGHT)	1
14	2580110	布案内 (左)	FABRIC GUIDE (LEFT)	1
15	258013-910	布案内	FABRIC GUIDE	1
16	0070200	平ネジ/M4×10	SCREW	2
17	3034480	座金	WASHER	2
18	250526C910	モーション (組)	MOTION ASSEMBLY	1
19	0070280	平ネジ/M5×10	SCREW	2
20	0045920	止ネジ/M6×12	SCREW	1
21	250517A0	クランク軸	CRANKSHAFT	1
22	251010A0	エキセンピン	ECCENTRIC PIN	1
23	2050970	座金	WASHER	1
24	0070410	皿ネジ/M3×6	SCREW	1

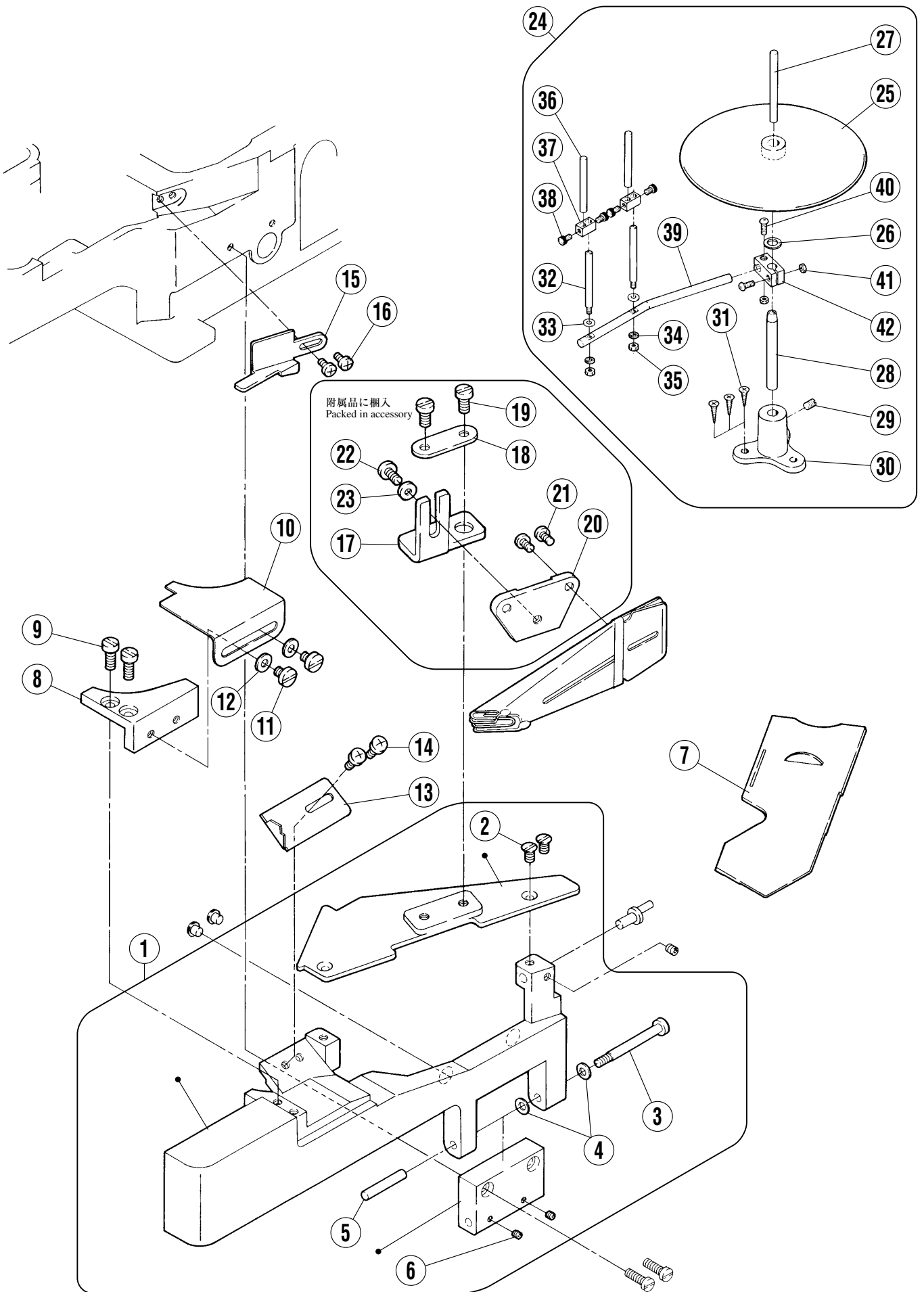

## 専用部品(2)

## SPECIFIC PARTS(2)

REF.NO.	PART NO.	部品名称	DESCRIPTION	QT.
1	250184-PD1	前カバー (組)	FRONT COVER ASSEMBLY	1
2	0070430	皿ネジ/M4×8	SCREW	2
3	2500130	ピン付ネジ/M4	SCREW	1
4	2011910	バネ座金	SPRING WASHER	2
5	2401980	平行ピン	PIN	1
6	0045540	止ネジ/M3×3	SCREW	2
7	250167A0	差し板	SLIDE PLATE	1
8	250186-PD0	前カバー (小)	FRONT COVER (SMALL)	1
9	0070270	平ネジ/M5×8	SCREW	2
10	2064390	補助板/前カバー	AUXILIARY PLATE (FRONT COVER)	1
11	0070790	平ネジ/M5×6	SCREW	2
12	2045850	座金	WASHER	2
13	2501930	衣除ケ	FABRIC GUARD	1
14	007017A0	平ネジ/M4×5	SCREW	2
15	2501960	カバー	COVER	1
16	007018A0	平ネジ/M4×6	SCREW	2
17	2501900	ブラケット	BRACKET	1
18	2064600	座金	WASHER	1
19	0070270	平ネジ/M5×8	SCREW	2
20	2501890	締付金具	CLAMP PLATE	1
21	0051130	平ネジ/C5×5.5	SCREW	2
22	0070270	平ネジ/M5×8	SCREW	1
23	2400420	座金	WASHER	1
24	000257A9S0	テープガイド (組)	TAPE GUIDE ASSEMBLY	1
25	000247-SA0	テープ台	TAPE BASE	1
26	0002700	座金	WASHER	1
27	0002530	平行ピン	PIN	1
28	0002500	取付棒 (下)	TAPE DISC POST	1
29	0014480	止ネジ/C9×5.2	SCREW	1
30	000251-SA0	ブラケット	BRACKET	1
31	0049130	木ネジ/5.8	SCREW	3
32	0002520	段付ネジ/M5	SCREW	2
33	2045850	座金	WASHER	2
34	3030670	バネ座金	SPRING WASHER	2
35	0002260	六角ナット/M5	NUT	2
36	0002530	平行ピン	PIN	2
37	0002540	ホルダー	HOLDER	2
38	0051610	平ネジ/C5×8	SCREW	4
39	0002550	取付棒/テープ案内	TAPE GUIDE BAR	1
40	007023A0	平ネジ/M4×16	SCREW	2
41	0048030	六角ナット/M4	NUT	2
42	000256-SA0	ホルダー	HOLDER	1

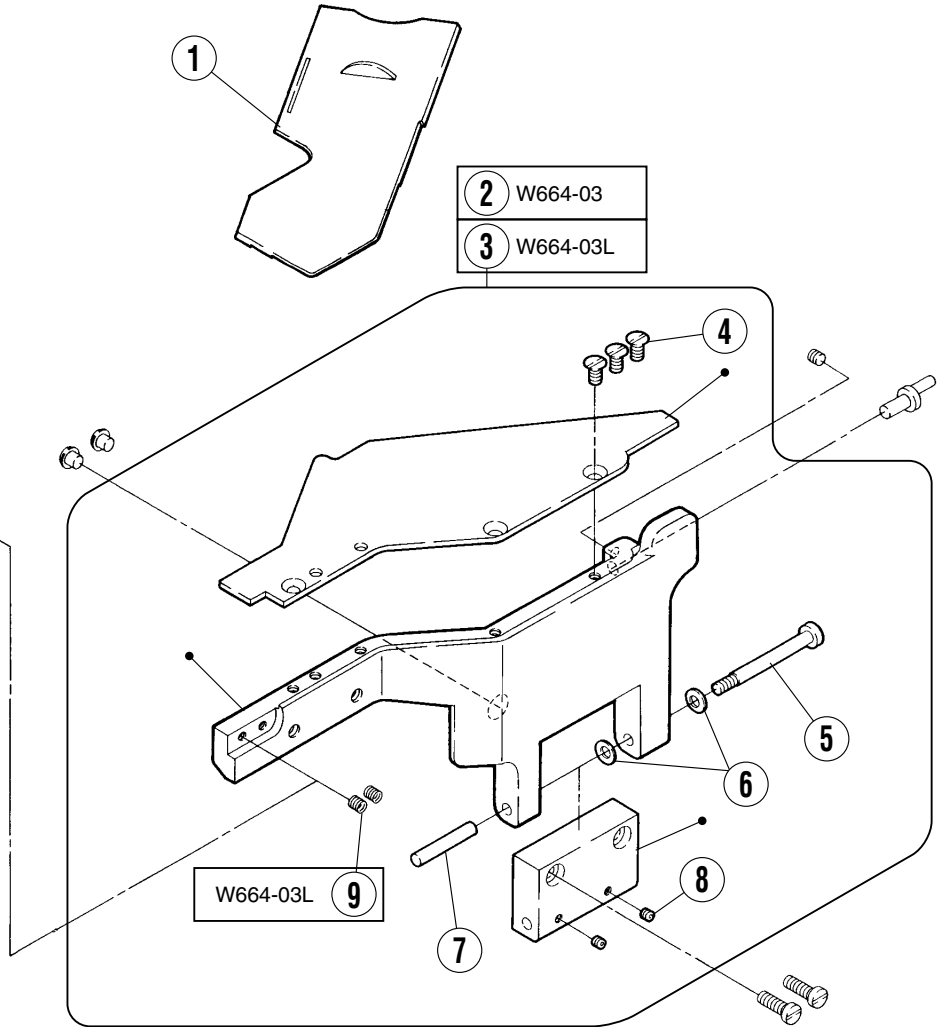
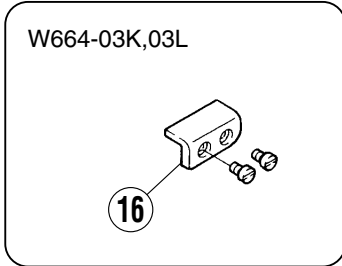
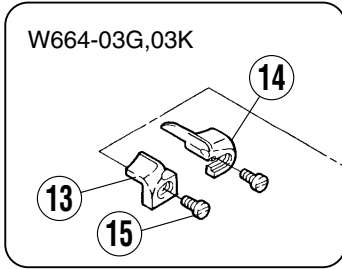
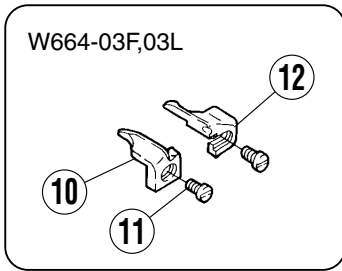

W664-03L

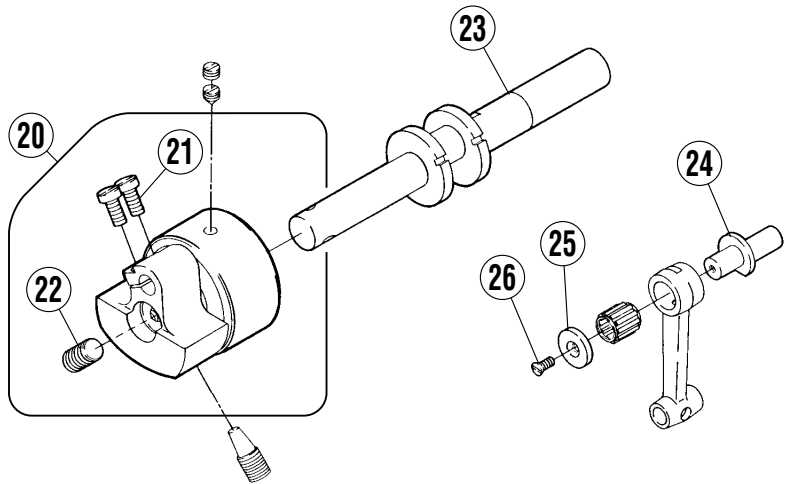
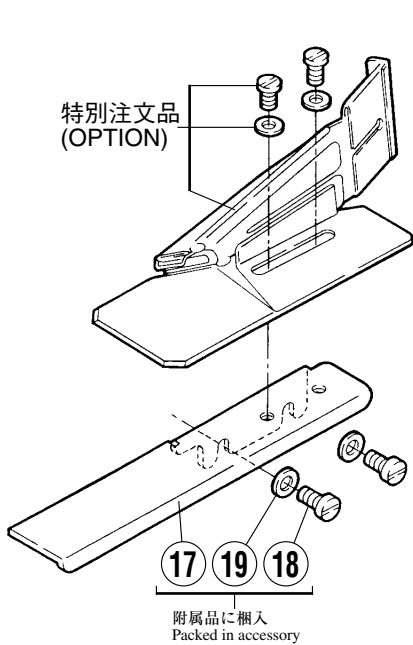



## 専用部品(3)

## SPECIFIC PARTS(3)

REF.NO.	PART NO.	部品名称	DESCRIPTION	QT.
1	2501670	差し板	SLIDE PLATE	1
2	250177BPD1	前カバー (組)	FRONT COVER ASSEMBLY	1
3	250177MPD1	前カバー (組)	FRONT COVER ASSEMBLY	1
4	0070430	皿ネジ/M4×8	SCREW	3
5	2500130	ピン付ネジ/M4	SCREW	1
6	2011910	バネ座金	SPRING WASHER	2
7	2401980	平行ピン	PIN	1
8	0045540	止ネジ/M3×3	SCREW	2
9	2400260	スプリュー	SPRUE	2
10	2575690	布案内 (左)	FABRIC GUIDE (LEFT)	1
11	0070090	平ネジ/M3×5	SCREW	2
12	2575700	布案内 (右)	FABRIC GUIDE (RIGHT)	1
13	2575750	布案内 (左)	FABRIC GUIDE (LEFT)	1
14	2575760	布案内 (右)	FABRIC GUIDE (RIGHT)	1
15	0070090	平ネジ/M3×5	SCREW	2
16	2502630	ブラケット	BRACKET	1
17	6A005600000	ブラケット (組)	BRACKET ASSEMBLY	1
18	0070280	平ネジ/M5×10	SCREW	2
19	2045850	座金	WASHER	2
20	250526C910	モーション (組)	MOTION ASSEMBLY	1
21	0070280	平ネジ/M5×10	SCREW	2
22	0045920	止ネジ/M6×12	SCREW	1
23	250517A0	クランク軸	CRANKSHAFT	1
24	251010A0	エキセンピン	ECCENTRIC PIN	1
25	2050970	座金	WASHER	1
26	0070410	皿ネジ/M3×6	SCREW	1

W664-05

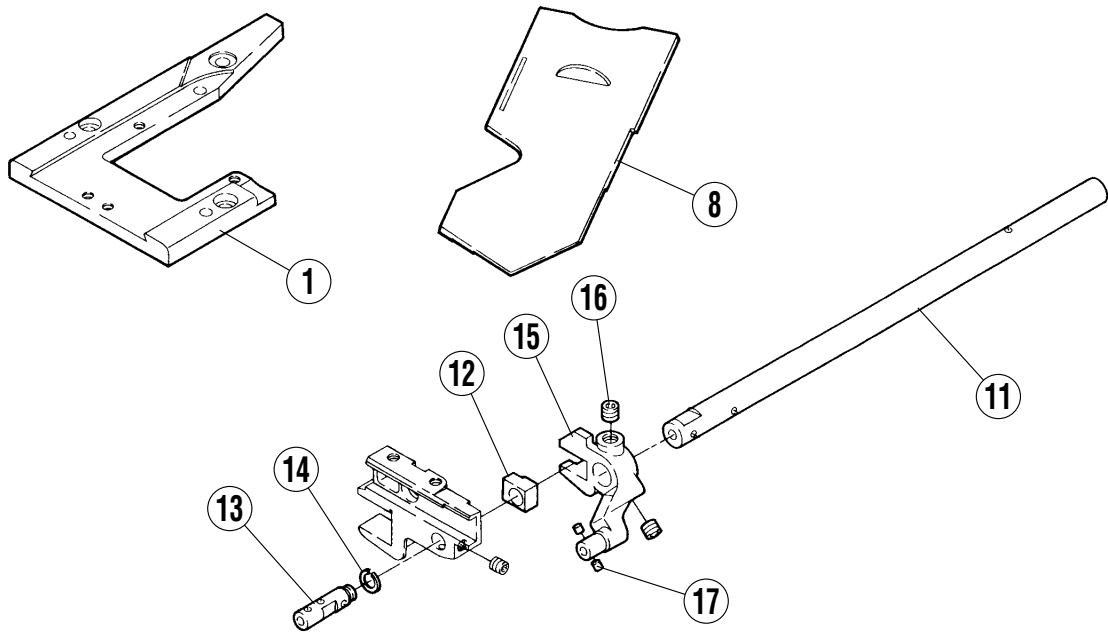

W664-05/FT240

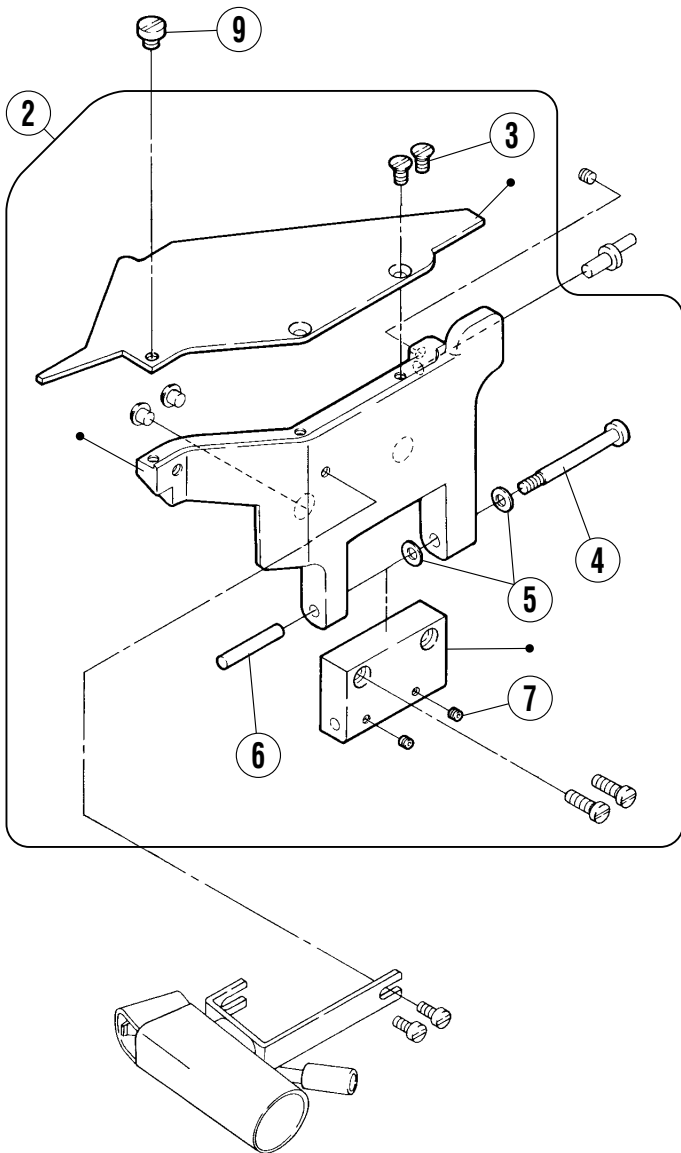

W664-05/FT240A

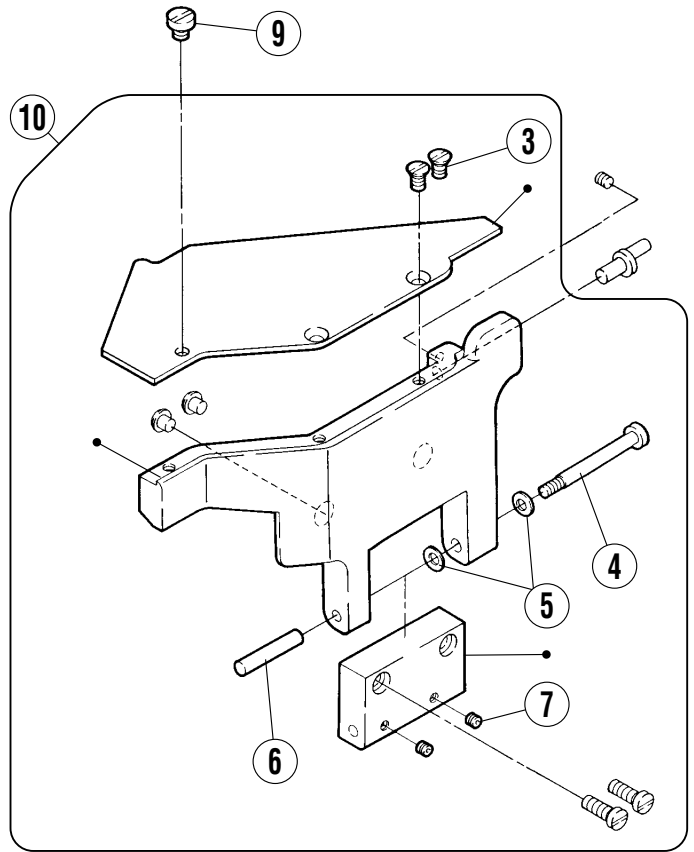

専用部品(4)

SPECIFIC PARTS(4)

REF.NO.	PART NO.	部品名称	DESCRIPTION	QT.
1	250168A0	ブラケット	BRACKET	1
2	250177CPD1	前カバー (組)	FRONT COVER ASSEMBLY	1
3	0070430	皿ネジ/M4×8	SCREW	2
4	2500130	ピン付ネジ/M4	SCREW	1
5	2011910	バネ座金	SPRING WASHER	2
6	2401980	平行ピン	PIN	1
7	0045540	止ネジ/M3×3	SCREW	2
8	250167A0	差シ板	SLIDE PLATE	1
9	0070740	平ネジ/M5×5	SCREW	1
10	250177HPD1	前カバー (組)	FRONT COVER ASSEMBLY	1
11	2555210	軸	SHAFT	1
12	252675A0	角駒	BLOCK	1
13	255523-C0	軸	SHAFT	1
14	3060110	止メ輪	RING	1
15	255522-920	クランク	CRANK	1
16	0045220	止ネジ/M6×6	SCREW	2
17	2079250	フェルト	FELT	2

W664-08A,08D

標準(Standard)  
 薄物用  
 For light weight fabric **8**  
 厚物用  
 For heavy weight fabric **9**  
 附属品に梱入  
 Packed in accessory

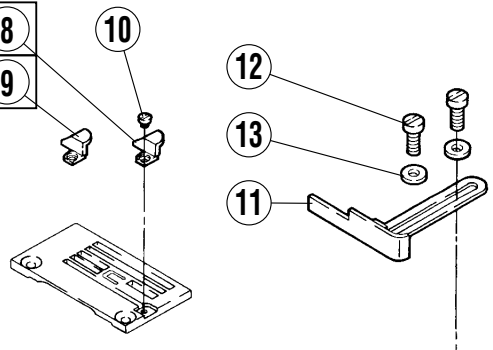

W664-08B,08E

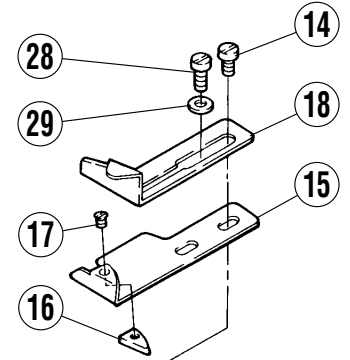
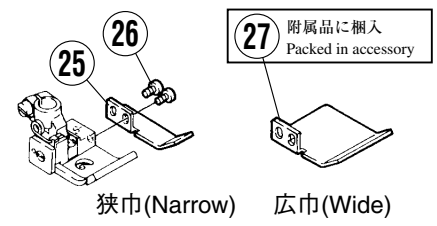

W664-08

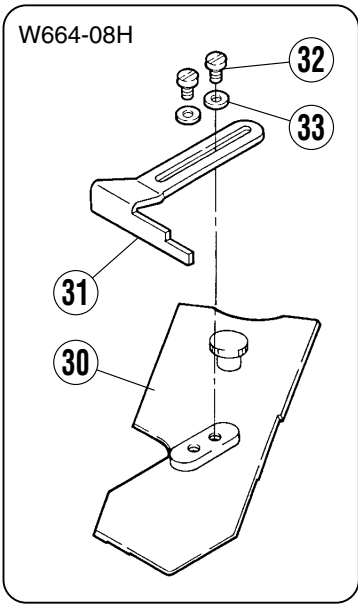

**7** W664-08Hを除く  
 Except W664-08H

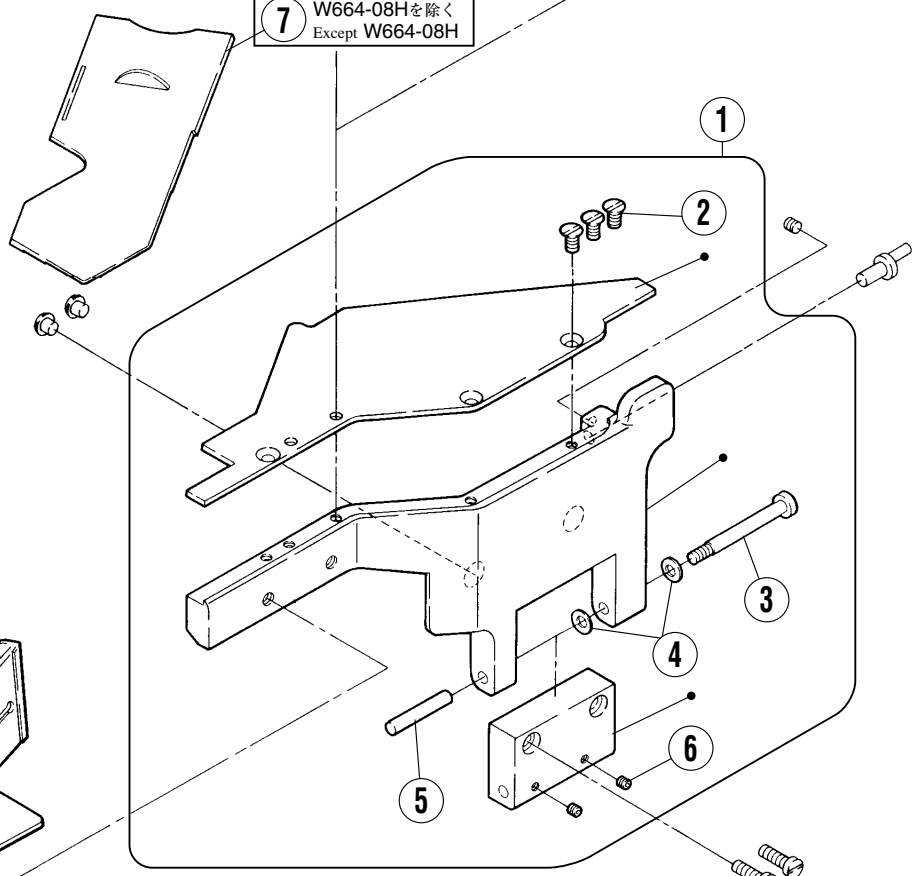

特別注文品  
 (OPTION)

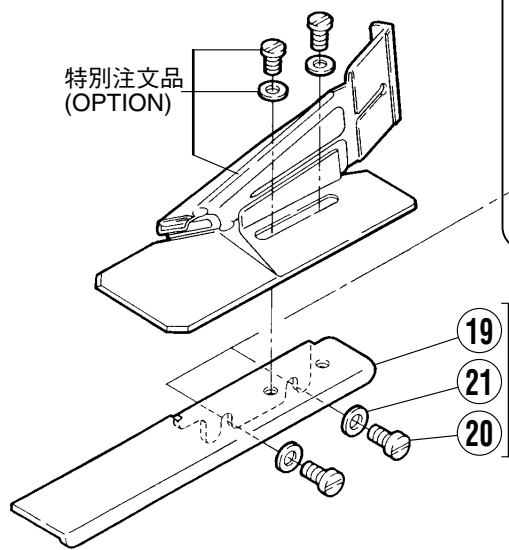

W664-08Hを除く  
 Except W664-08H  
 附属品に梱入  
 Packed in accessory

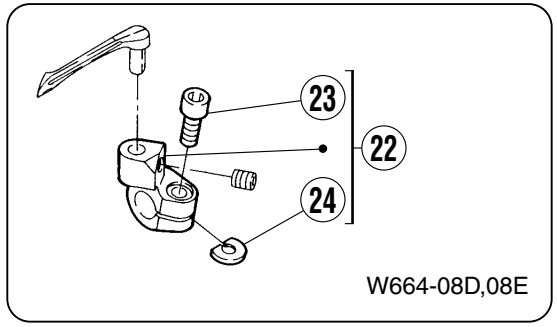

W664-08D,08E

専用部品(5)

SPECIFIC PARTS(5)

REF.NO.	PART NO.	部品名称	DESCRIPTION	QT.
1	250177APD1	前カバー (組)	FRONT COVER ASSEMBLY	1
2	0070430	皿ネジ/M4×8	SCREW	3
3	2500130	ピン付ネジ/M4	SCREW	1
4	2011910	バネ座金	SPRING WASHER	2
5	2401980	平行ピン	PIN	1
6	0045540	止ネジ/M3×3	SCREW	2
7	250167A0	差シ板	SLIDE PLATE	1
8	2575710	裾引定規	HEMMING GUIDE	1
9	2575720	裾引定規	HEMMING GUIDE	1
10	0071200	平ネジ/M2×3	SCREW	1
11	258013-910	布案内	FABRIC GUIDE	1
12	0070200	平ネジ/M4×10	SCREW	2
13	3034480	座金	WASHER	2
14	0070190	平ネジ/M4×8	SCREW	1
15	2575771	裾引定規 (左)	HEMMING GUIDE (LEFT)	1
16	2575790	スペーサー	SPACER	1
17	0070710	皿ネジ/M2×3	SCREW	1
18	2575780	裾引定規 (右)	HEMMING GUIDE (RIGHT)	1
19	6A005600000	ブラケット (組)	BRACKET ASSEMBLY	1
20	0070280	平ネジ/M5×10	SCREW	2
21	2045850	座金	WASHER	2
22	252053A920	ルーバー台	LOOPER HOLDER	1
23	0071450	六角穴ボルト	BOLT	1
24	2520550	座金	WASHER	1
25	257761A0	押工補助板	FABRIC GUIDE	1
26	0070310	平ネジ/M2.5×4	SCREW	2
27	2577610	押工補助板	FABRIC GUIDE	1
28	0070200	平ネジ/M4×10	SCREW	1
29	3034480	座金	WASHER	1
30	250321-910	差シ板 (組)	SLIDE PLATE ASSEMBLY	1
31	2580140	布案内	FABRIC GUIDE	1
32	0070180	平ネジ/M4×6	SCREW	2
33	3034480	座金	WASHER	2

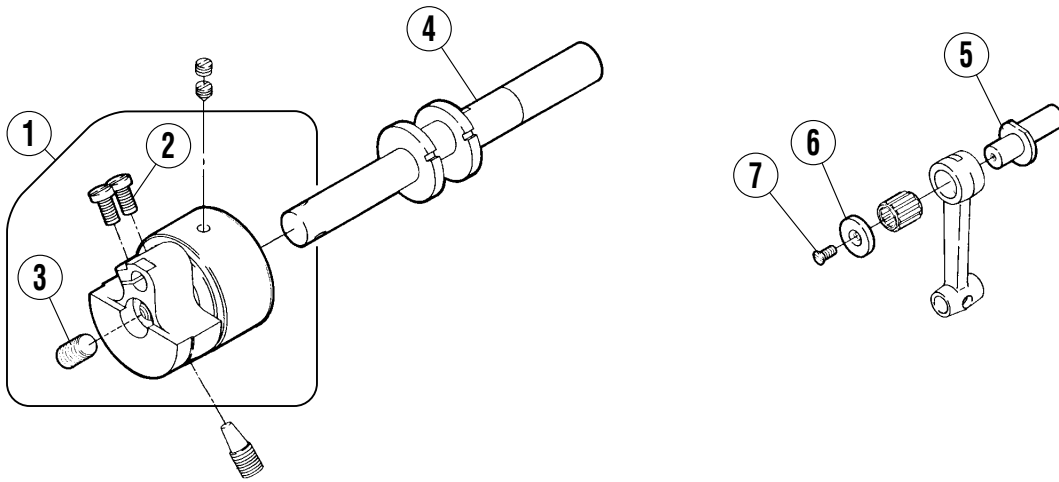

W664-34

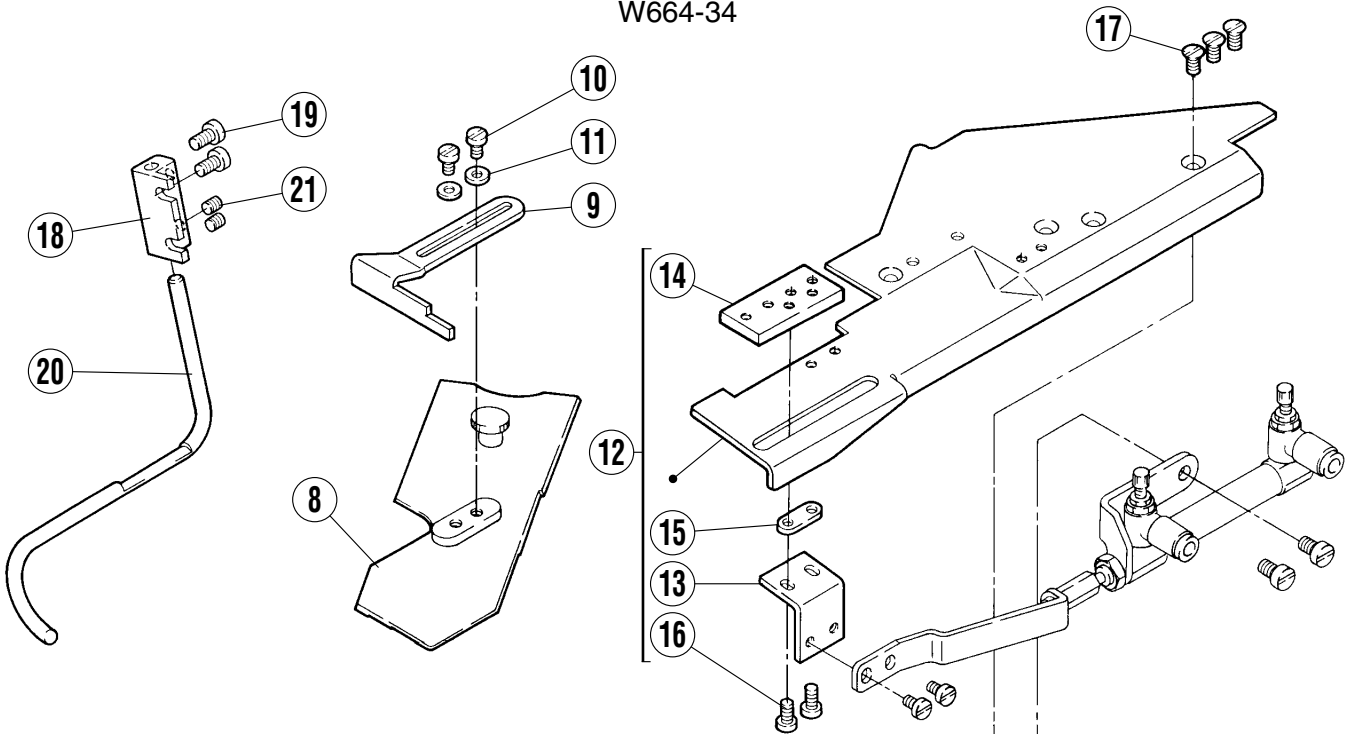

W664-34,35

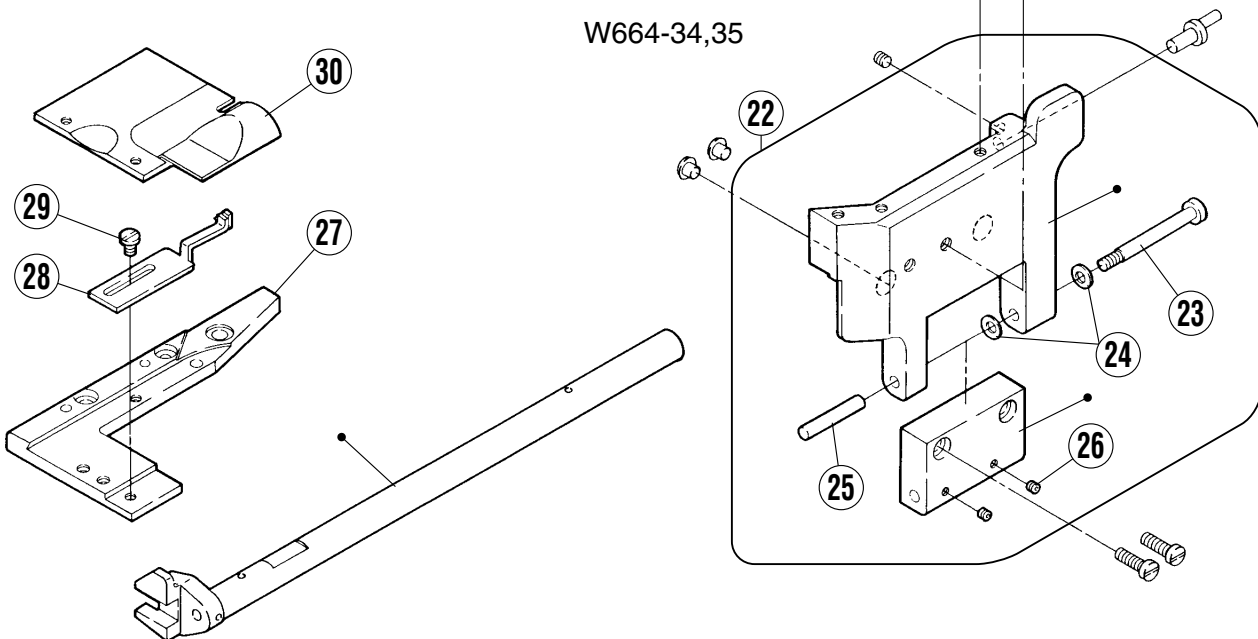

専用部品(6)

SPECIFIC PARTS(6)

REF.NO.	PART NO.	部品名称	DESCRIPTION	QT.
1	250526C910	モーション (組)	MOTION ASSEMBLY	1
2	0070280	平ネジ/M5×10	SCREW	2
3	0045920	止ネジ/M6×12	SCREW	1
4	250517A0	クランク軸	CRANKSHAFT	1
5	251010A0	エキセンピン	ECCENTRIC PIN	1
6	2050970	座金	WASHER	1
7	0070410	皿ネジ/M3×6	SCREW	1
8	250321-910	差シ板 (組)	SLIDE PLATE ASSEMBLY	1
9	2580140	布案内	FABRIC GUIDE	1
10	0070180	平ネジ/M4×6	SCREW	2
11	3034480	座金	WASHER	2
12	250264-910	補助板 (組) / 前カバー	AUXILIARY PLATE (FRONT COVER)	1
13	2580270	ブラケット	BRACKET	1
14	2580240	ブラケット	BRACKET	1
15	2580260	座金	WASHER	1
16	0070190	平ネジ/M4×8	SCREW	2
17	0070430	皿ネジ/M4×8	SCREW	3
18	2580470	ブラケット	BRACKET	1
19	007019A0	平ネジ/M4×8	SCREW	2
20	258046A0	案内棒	GUIDE BAR	1
21	0045430	止ネジ/M4×4	SCREW	2
22	250177DPD1	前カバー (組)	FRONT COVER ASSEMBLY	1
23	2500130	ピン付ネジ/M4	SCREW	1
24	2011910	バネ座金	SPRING WASHER	2
25	2401980	平行ピン	PIN	1
26	0045540	止ネジ/M3×3	SCREW	2
27	250168B0	ブラケット	BRACKET	1
28	258049-910	補助案内 (組)	AUXILIARY PLATE ASSEMBLY	1
29	0071430	平ネジ/M4×5.5	SCREW	1
30	250210-910	クロスプレート (組)	CLOTH PLATE ASSEMBLY	1

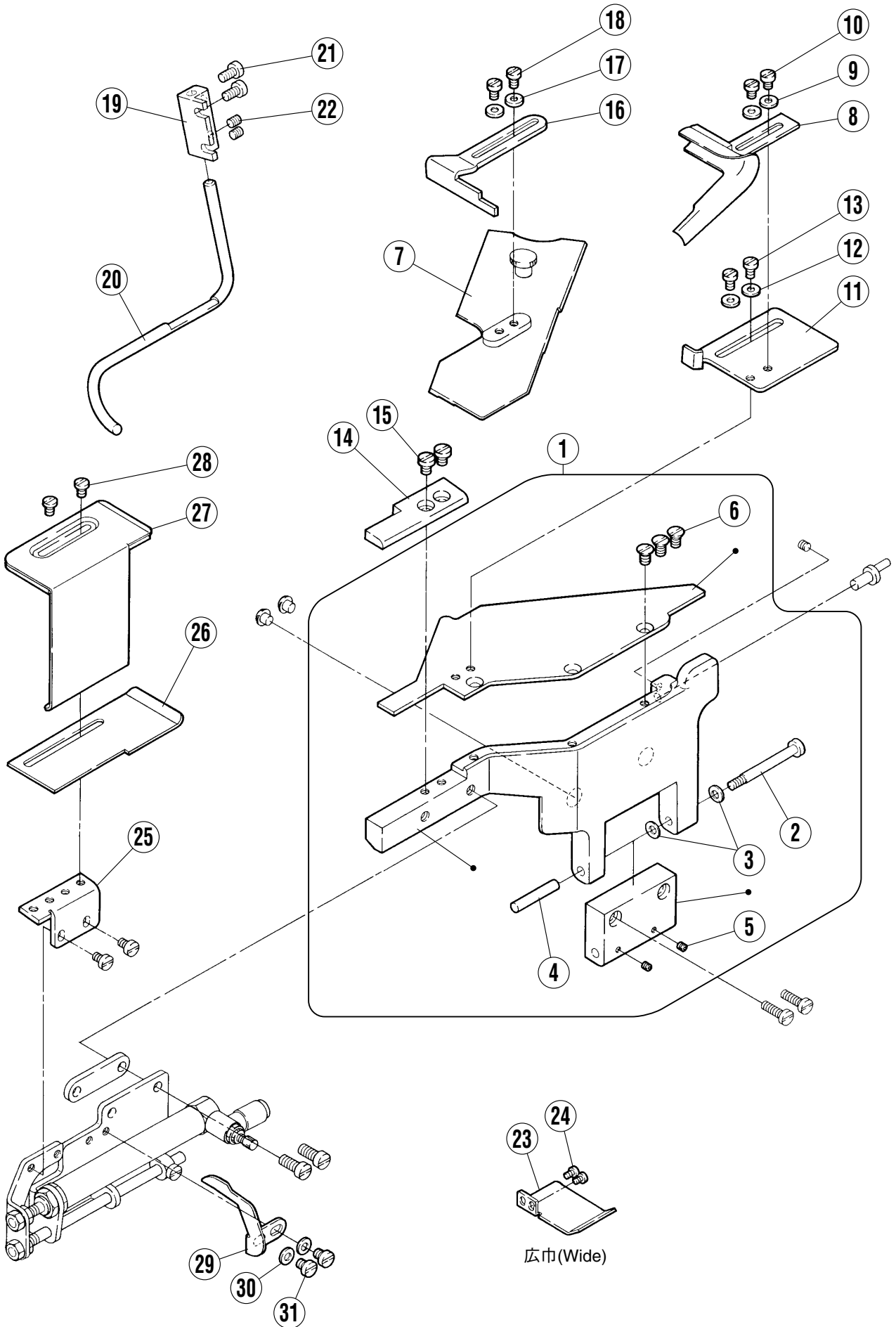



## 専用部品(7)

## SPECIFIC PARTS(7)

REF.NO.	PART NO.	部品名称	DESCRIPTION	QT.
1	250177GPD1	前カバー (組)	FRONT COVER ASSEMBLY	1
2	2500130	ピン付ネジ/M4	SCREW	1
3	2011910	バネ座金	SPRING WASHER	2
4	2401980	平行ピン	PIN	1
5	0045540	止ネジ/M3×3	SCREW	2
6	0070430	皿ネジ/M4×8	SCREW	3
7	250321-910	差し板 (組)	SLIDE PLATE ASSEMBLY	1
8	258050-910	バインダー (組)	BINDER ASSEMBLY	1
9	3034480	座金	WASHER	2
10	0070170	平ネジ/M4×5	SCREW	2
11	258015B910	布案内 (組)	FABRIC GUARD ASSEMBLY	1
12	3034480	座金	WASHER	2
13	0070180	平ネジ/M4×6	SCREW	2
14	2502540	ブラケット	BRACKET	1
15	0070180	平ネジ/M4×6	SCREW	2
16	2580140	布案内	FABRIC GUIDE	1
17	3034480	座金	WASHER	2
18	0070180	平ネジ/M4×6	SCREW	2
19	2580470	ブラケット	BRACKET	1
20	258046A0	案内棒	GUIDE BAR	1
21	007019A0	平ネジ/M4×8	SCREW	2
22	0045430	止ネジ/M4×4	SCREW	2
23	2577610	押工補助板	FABRIC GUIDE	1
24	0070310	平ネジ/M2.5×4	SCREW	2
25	2580740	ブラケット	BRACKET	1
26	2580230	バインダー	BINDER	1
27	258020A910	ゴム定規 (組)	ELASTIC GUIDE ASSEMBLY	1
28	0071430	平ネジ/M4×5.5	SCREW	2
29	2580730	布案内	FABRIC GUIDE	1
30	3034480	座金	WASHER	2
31	0070170	平ネジ/M4×5	SCREW	2

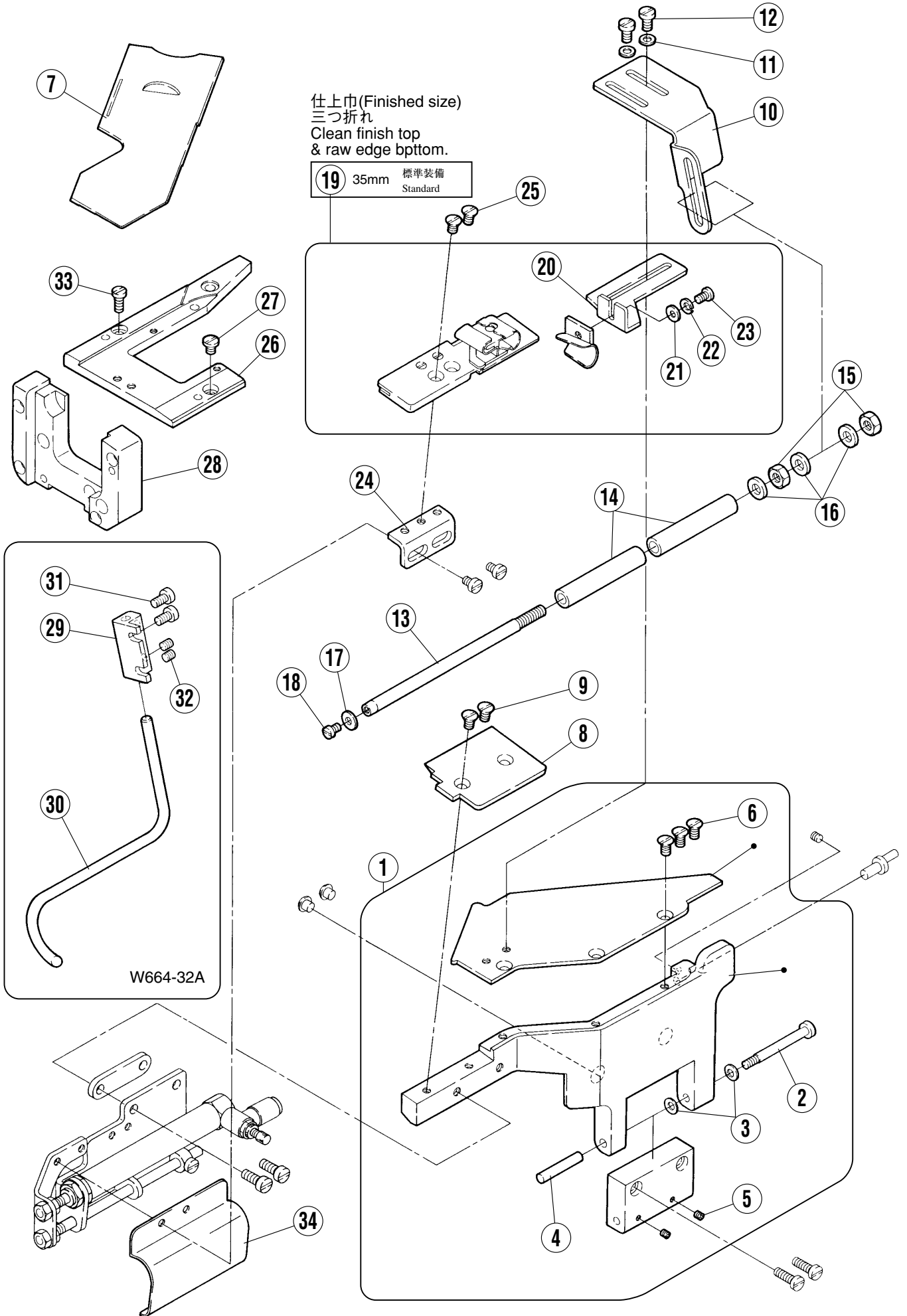

## 専用部品(8)

## SPECIFIC PARTS(8)

REF.NO.	PART NO.	部品名称	DESCRIPTION	QT.
1	250177FPD1	前カバー (組)	FRONT COVER ASSEMBLY	1
2	2500130	ピン付ネジ/M4	SCREW	1
3	2011910	バネ座金	SPRING WASHER	2
4	2401980	平行ピン	PIN	1
5	0045540	止ネジ/M3×3	SCREW	2
6	0070430	皿ネジ/M4×8	SCREW	3
7	250167A0	差し板	SLIDE PLATE	1
8	2502520	クロスプレート	CLOTH PLATE	1
9	0070770	皿ネジ/M4×7	SCREW	2
10	2580720	ブラケット	BRACKET	1
11	3034480	座金	WASHER	2
12	0070190	平ネジ/M4×8	SCREW	2
13	3069410	軸	SHAFT	1
14	3069400	ローラー	ROLLER	2
15	0031440	六角ナット/C8	NUT	2
16	2082860	座金	WASHER	3
17	1670660	座金	WASHER	1
18	0012060	平ネジ/C4×5.3	SCREW	1
19	258069B910	バインダ (組) 35mm	BINDER ASSEMBLY 35mm	1
20	2580710	ブラケット	BRACKET	1
21	1379060	座金	WASHER	1
22	2012520	バネ座金	SPRING WASHER	1
23	005328-HC0	平ネジ/C4×6.3	SCREW	1
24	2580680	ブラケット	BRACKET	1
25	0070770	皿ネジ/M4×7	SCREW	2
26	250168C0	針板ブラケット	NEEDLE PLATE BRACKET	1
27	0071430	平ネジ/M4×5.5	SCREW	1
28	250280APD0	横カバー	SIDE COVER	1
29	2580470	ブラケット	BRACKET	1
30	2580460	案内棒	GUIDE BAR	1
31	007019A0	平ネジ/M4×8	SCREW	2
32	0045430	止ネジ/M4×4	SCREW	2
33	0070200	平ネジ/M4×10	SCREW	1
34	2580930	カバー	COVER	1

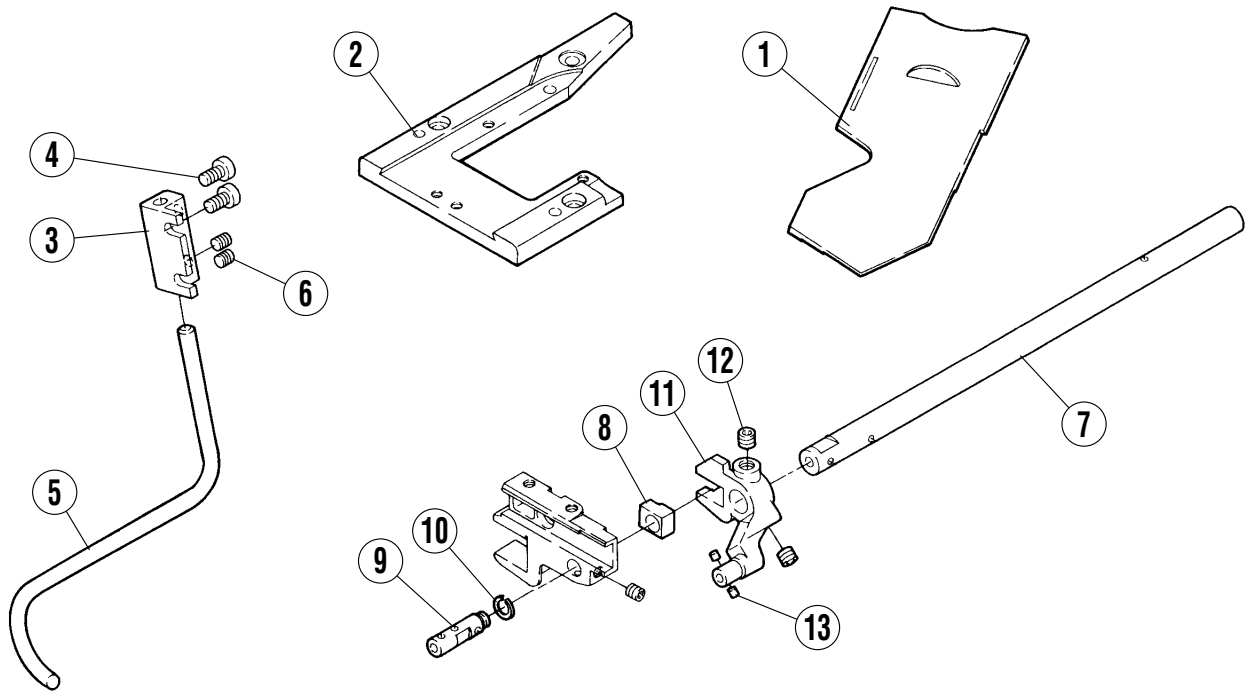

W664-33A/FT241

W664-33A/FT221  
W664-33B/FT242A, FT222

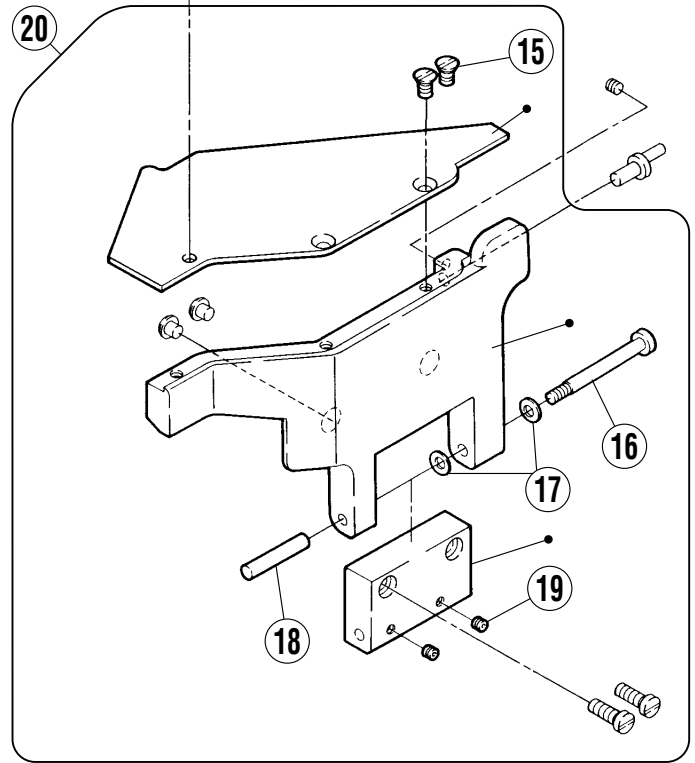
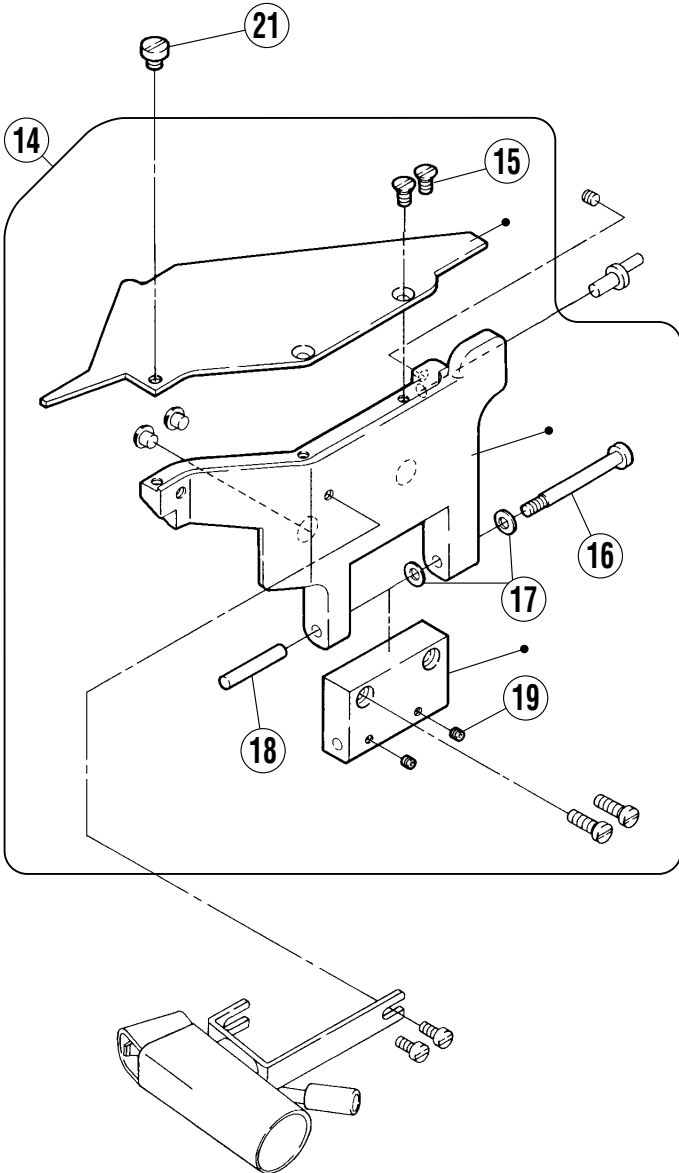

専用部品(9)

SPECIFIC PARTS(9)

REF.NO.	PART NO.	部品名称	DESCRIPTION	QT.
1	250167A0	差シ板	SLIDE PLATE	1
2	250168A0	ブラケット	BRACKET	1
3	2580470	ブラケット	BRACKET	1
4	007019A0	平ネジ/M4×8	SCREW	2
5	2580460	案内棒	GUIDE BAR	1
6	0045430	止ネジ/M4×4	SCREW	2
7	2555210	軸	SHAFT	1
8	252675A0	角駒	BLOCK	1
9	255523-C0	軸	SHAFT	1
10	3060110	止メ輪	RING	1
11	255522-920	クランク	CRANK	1
12	0045220	止ネジ/M6×6	SCREW	2
13	2079250	フェルト	FELT	2
14	250177CPD1	前カバー (組)	FRONT COVER ASSEMBLY	1
15	0070430	皿ネジ/M4×8	SCREW	2
16	2500130	ピン付ネジ/M4	SCREW	1
17	2011910	バネ座金	SPRING WASHER	2
18	2401980	平行ピン	PIN	1
19	0045540	止ネジ/M3×3	SCREW	2
20	250177HPD1	前カバー (組)	FRONT COVER ASSEMBLY	1
21	0070740	平ネジ/M5×5	SCREW	1

W664-34A,35A

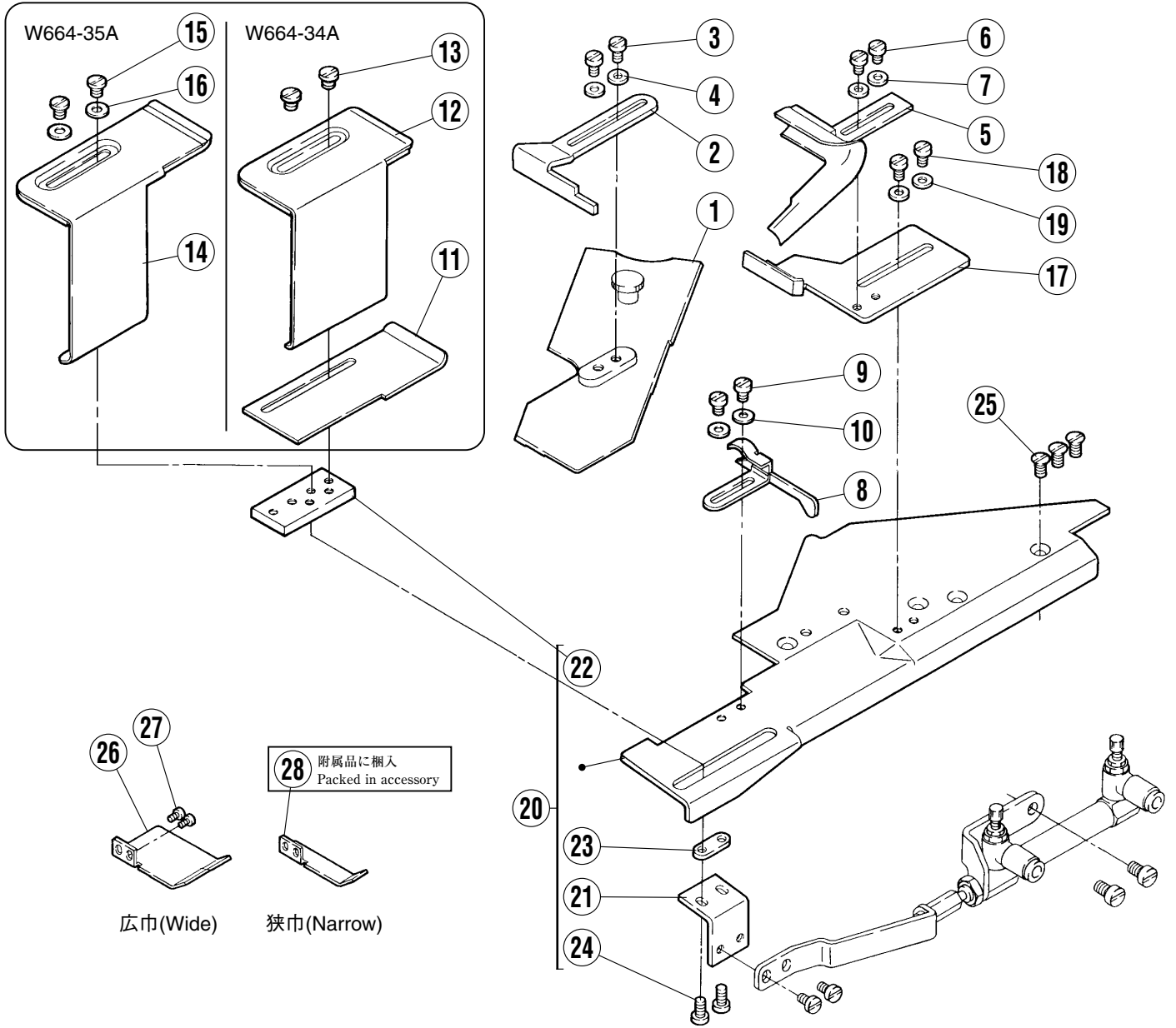

W664-35B,35D

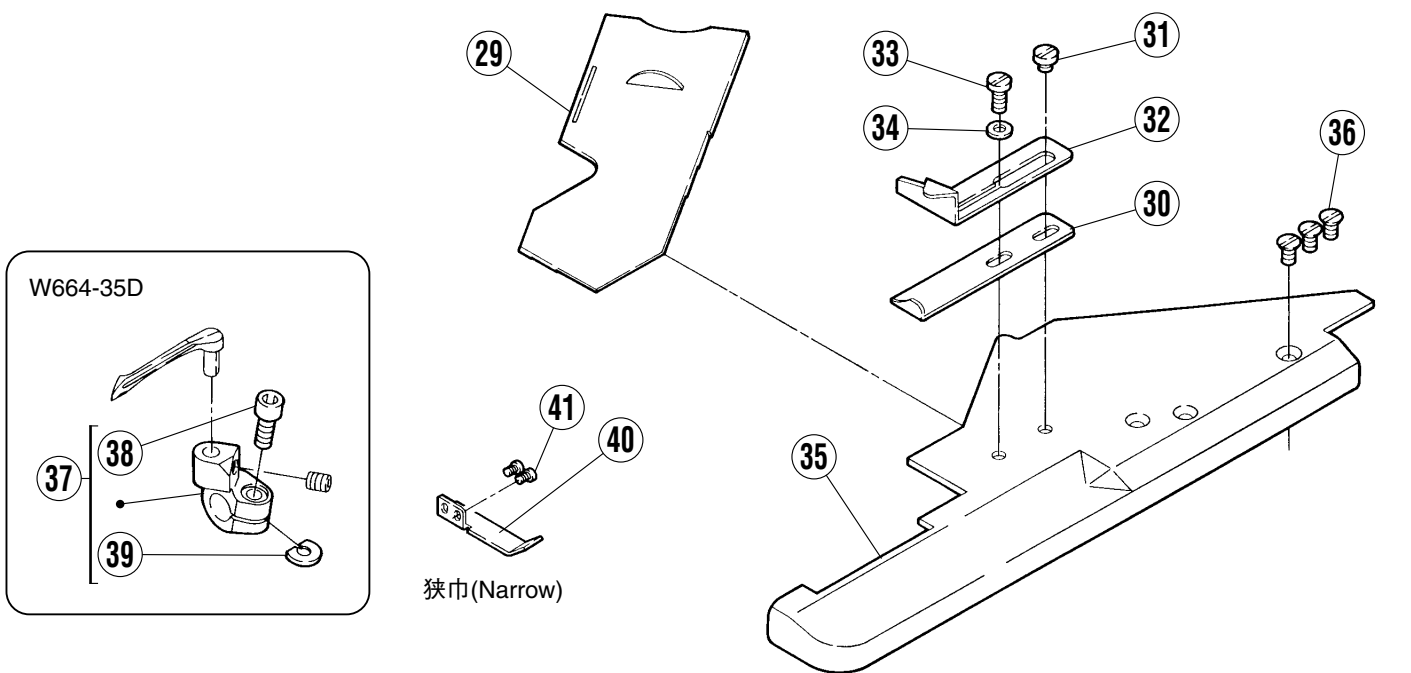

## 専用部品(10)

## SPECIFIC PARTS(10)

REF.NO.	PART NO.	部品名称	DESCRIPTION	QT.
1	250321-910	差し板 (組)	SLIDE PLATE ASSEMBLY	1
2	2580140	布案内	FABRIC GUIDE	1
3	0070180	平ネジ/M4×6	SCREW	2
4	3034480	座金	WASHER	2
5	258050-910	バインダー (組)	BINDER ASSEMBLY	1
6	0070170	平ネジ/M4×5	SCREW	2
7	3034480	座金	WASHER	2
8	258017B910	布案内 (組)	FABRIC GUARD ASSEMBLY	1
9	0070170	平ネジ/M4×5	SCREW	2
10	3034480	座金	WASHER	2
11	2580230	バインダー	BINDER	1
12	258020A910	ゴム定規 (組)	ELASTIC GUIDE ASSEMBLY	1
13	0071430	平ネジ/M4×5.5	SCREW	2
14	258020B910	ゴム定規	ELASTIC GUIDE	1
15	0071430	平ネジ/M4×5.5	SCREW	2
16	3034480	座金	WASHER	2
17	258015A910	布案内 (組)	FABRIC GUARD ASSEMBLY	1
18	0070180	平ネジ/M4×6	SCREW	2
19	3034480	座金	WASHER	2
20	250264-910	補助板 (組) / 前カバー	AUXILIARY PLATE (FRONT COVER)	1
21	2580270	ブラケット	BRACKET	1
22	2580240	ブラケット	BRACKET	1
23	2580260	座金	WASHER	1
24	0070190	平ネジ/M4×8	SCREW	2
25	0070430	皿ネジ/M4×8	SCREW	3
26	2577430	押工補助板	FABRIC GUIDE	1
27	0070310	平ネジ/M2.5×4	SCREW	2
28	257743A0	押工補助板	FABRIC GUIDE	1
29	250167A0	差し板	SLIDE PLATE	1
30	257577A0	裾引定規 (左)	HEMMING GUIDE (LEFT)	1
31	0071960	平ネジ/M4×4	SCREW	1
32	2575780	裾引定規 (右)	HEMMING GUIDE (RIGHT)	1
33	0070180	平ネジ/M4×6	SCREW	1
34	3034480	座金	WASHER	1
35	2502810	補助板 / 前カバー	AUXILIARY PLATE (FRONT COVER)	1
36	0070430	皿ネジ/M4×8	SCREW	3
37	252053A920	ルーバー台	LOOPER HOLDER	1
38	0071450	六角穴ボルト	BOLT	1
39	2520550	座金	WASHER	1
40	257743A0	押工補助板	FABRIC GUIDE	1
41	0070310	平ネジ/M2.5×4	SCREW	2

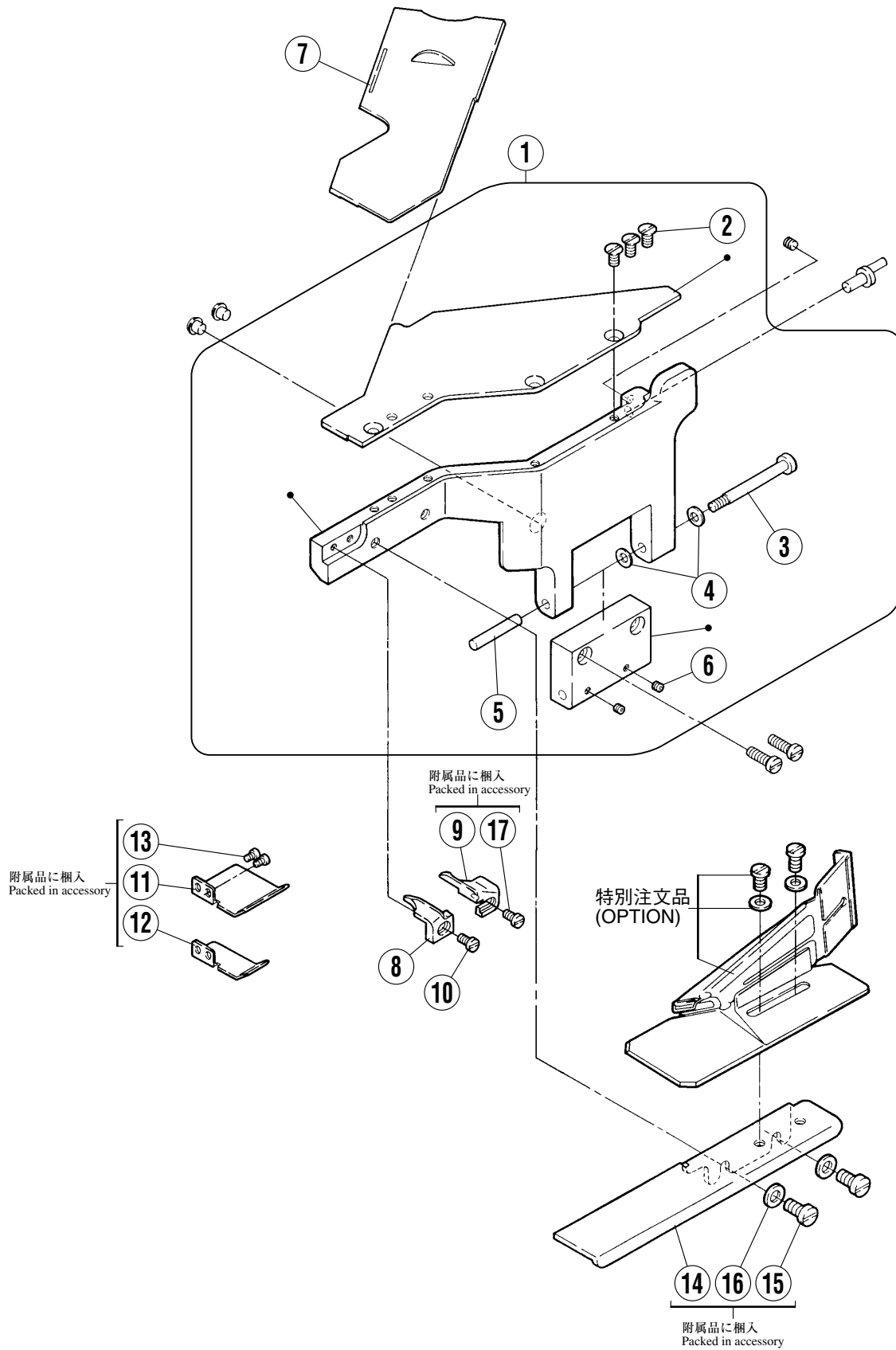



専用部品(11)

SPECIFIC PARTS(11)

REF.NO.	PART NO.	部品名称	DESCRIPTION	QT.
1	250177EPD1	前カバー (組)	FRONT COVER ASSEMBLY	1
2	0070430	皿ネジ/M4×8	SCREW	3
3	2500130	ピン付ネジ/M4	SCREW	1
4	2011910	バネ座金	SPRING WASHER	2
5	2401980	平行ピン	PIN	1
6	004554	止ネジ/M3×3	SCREW	2
7	250167A0	差し板	SLIDE PLATE	1
8	2575690	布案内 (左)	CLOTH GUIDE (LEFT)	1
9	2575700	布案内 (右)	FABRIC GUIDE (RIGHT)	1
10	0070090	平ネジ/M3×5	SCREW	1
11	2577610	押工補助板	FABRIC GUIDE	1
12	257761A0	押工補助板	FABRIC GUIDE	1
13	0070310	平ネジ/M2.5×4	SCREW	2
14	6A005600000	ブラケット (組)	BRACKET ASSEMBLY	1
15	0070280	平ネジ/M5×10	SCREW	2
16	2045850	座金	WASHER	2
17	0070090	平ネジ/M3×5	SCREW	1

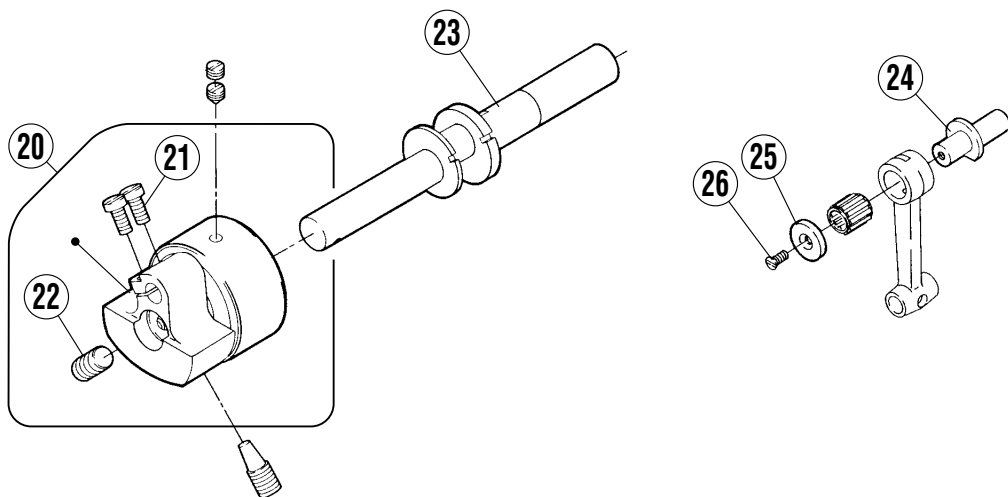
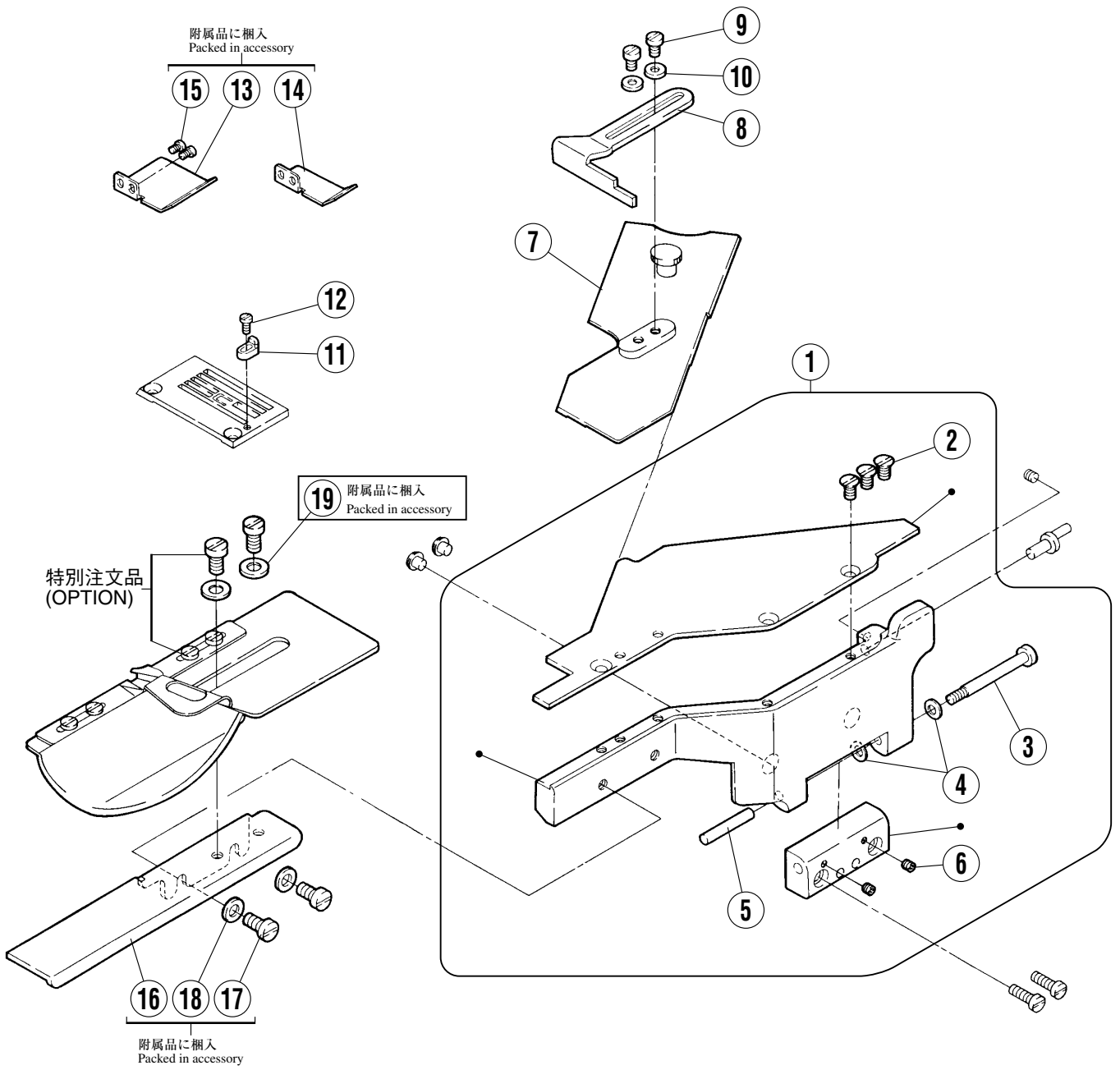

## 専用部品(12)

## SPECIFIC PARTS(12)

REF.NO.	PART NO.	部品名称	DESCRIPTION	QT.
1	350247-PD1	前カバー (組)	FRONT COVER ASSEMBLY	1
2	007040	皿ネジ/M4×8	SCREW	3
3	2500130	ピン付ネジ/M4	SCREW	1
4	2011910	バネ座金	SPRING WASHER	2
5	2401980	平行ピン	PIN	1
6	0045540	止ネジ/M3×3	SCREW	2
7	250321-910	差し板 (組)	SLIDE PLATE ASSEMBLY	1
8	2580140	布案内	FABRIC GUIDE	1
9	0070180	平ネジ/M4×6	SCREW	2
10	3034480	座金	WASHER	2
11	2077860	身頃案内	CLOTH GUIDE	1
12	0070320	平ネジ/M2.5×6	SCREW	1
13	2577610	押工補助板	FABRIC GUIDE	1
14	257761A0	押工補助板	FABRIC GUIDE	1
15	0070310	平ネジ/M2.5×6	SCREW	2
16	6A005600000	ブラケット (組)	BRACKET ASSEMBLY	1
17	0070280	平ネジ/M5×10	SCREW	2
18	2045850	座金	WASHER	2
19	2350400	座金	WASHER	2
20	250526C910	モーション (組)	MOTION ASSEMBLY	1
21	0070280	平ネジ/M5×10	SCREW	2
22	0045920	止ネジ/M6×12	SCREW	1
23	250517A0	クランク軸	CRANKSHAFT	1
24	251010A0	エキセンピン	ECCENTRIC PIN	1
25	2050970	座金	WASHER	1
26	0070410	皿ネジ/M3×6	SCREW	1

W664-01M,03M,05M,08M,08N,35M,35N

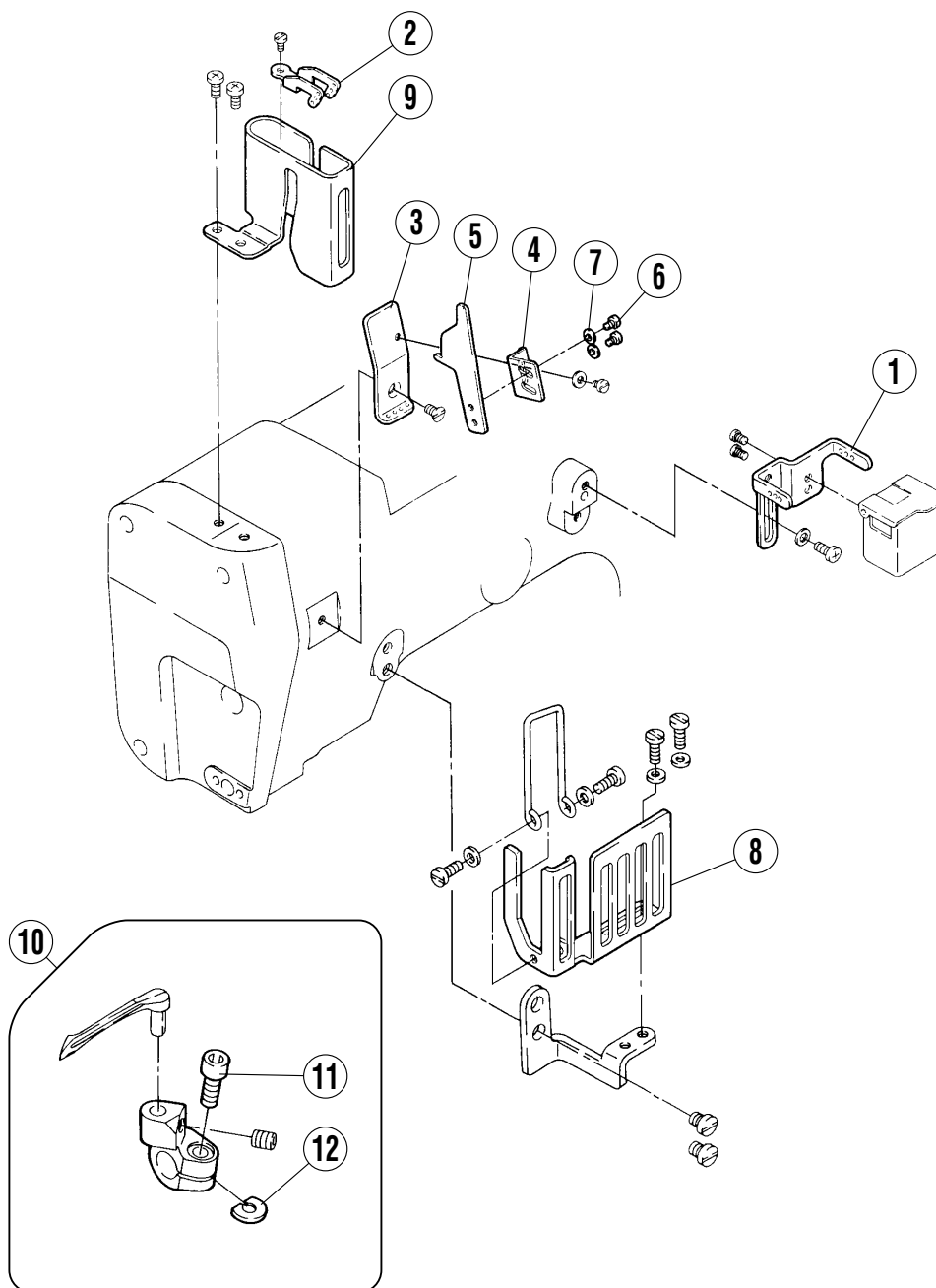

専用部品(13)

SPECIFIC PARTS(13)

REF.NO.	PART NO.	部品名称	DESCRIPTION	QT.
1	2536780	ブラケット	BRACKET	1
2	2536770	糸道	THREAD GUIDE	1
3	2536840	糸道	THREAD GUIDE	1
4	2536830	ブラケット	BRACKET	1
5	2536820	針糸カム	NEEDLE THREAD CAM	1
6	0071540	平ネジ/M3×3.5	SCREW	2
7	2028750	座金	WASHER	2
8	2504340	糸繰りガード	THREAD TAKE-UP GUARD	1
9	2504350	針棒ガード	NEEDLE BAR GUARD	1
10	252053A920	ルーパー台(組)	LOOPER HOLDER ASSEMBLY	1
11	0071450	六角穴ボルト/M3.5×9.5	BOLT	1
12	2520550	座金	WASHER	1

W664-05/FT240,FT240A  
 W664-33A/FT241  
 W664-33B/FT242A

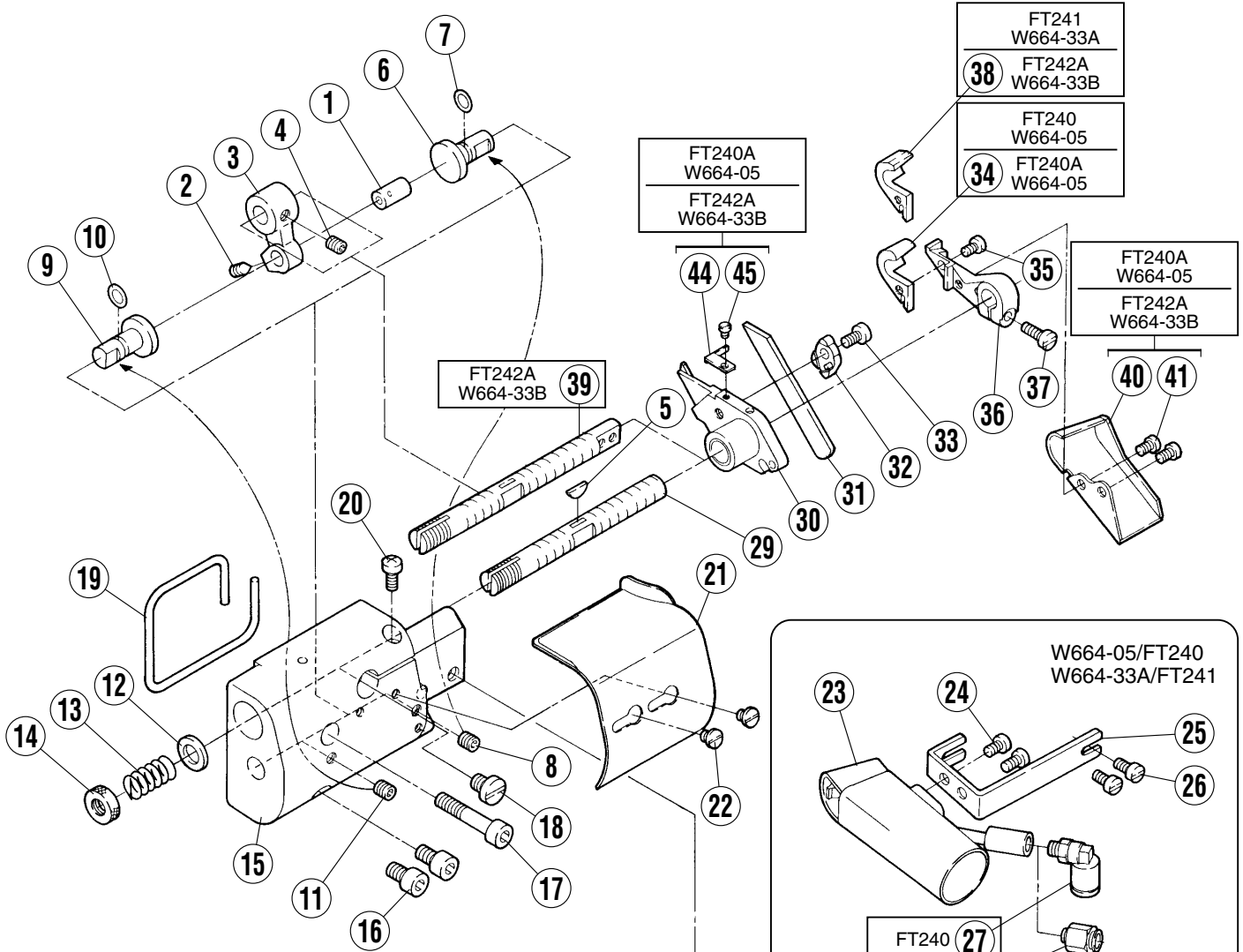

FT241 W664-33A
<b>38</b> FT242A W664-33B

FT240 W664-05
<b>34</b> FT240A W664-05

FT240A W664-05
FT242A W664-33B

FT240A W664-05
FT242A W664-33B

FT242A W664-33B
--------------------

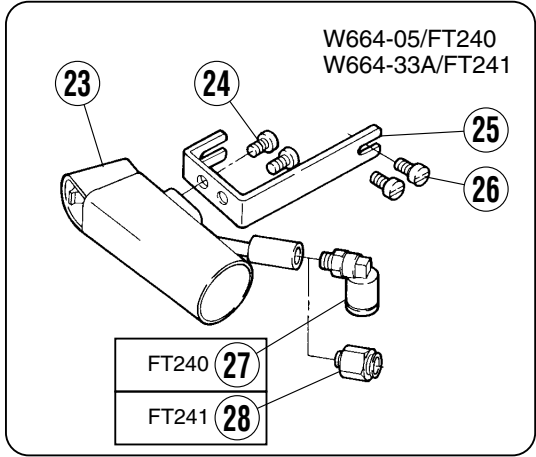

FT240	<b>27</b>
FT241	<b>28</b>

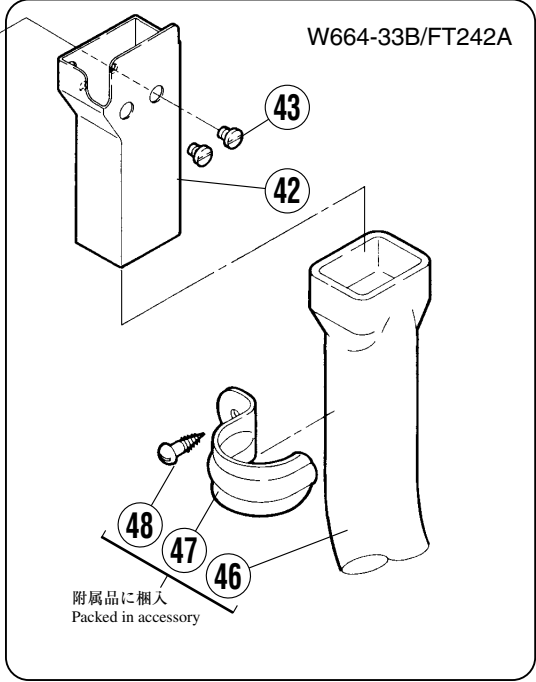
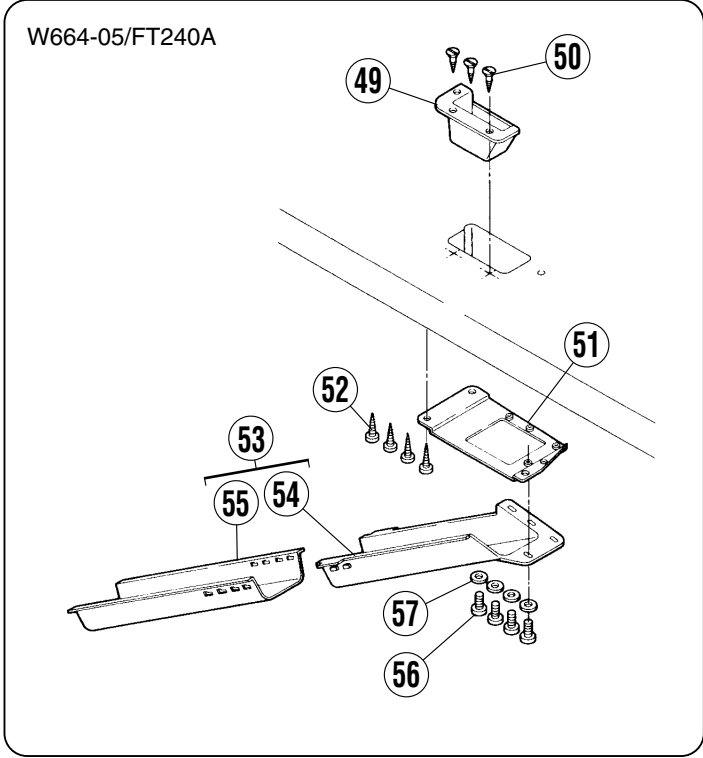

附属品に梱入  
 Packed in accessory

## FT装置 [-05,33]

## FT DEVICE [-05,33]

REF.NO.	PART NO.	部品名称	DESCRIPTION	QT.
1	2555250	平行ピン	PIN	1
2	0045530	止ネジ/M4×6	SCREW	1
3	2555260	クランク	CRANK	1
4	0045140	止ネジ/M5×5	SCREW	1
5	2400080	半月キー	KEY	1
6	2555270	案内軸 (右)	GUIDE SHAFT (RIGHT)	1
7	2402510	Oリング	O RING	1
8	0045390	止ネジ/M5×6	SCREW	1
9	2555280	案内軸 (左)	GUIDE SHAFT (LEFT)	1
10	2402510	Oリング	O RING	1
11	0045390	止ネジ/M5×6	SCREW	1
12	2300300	座金	WASHER	1
13	2555480	圧縮バネ	SPRING	1
14	2555460	丸ナット	NUT	1
15	255519-9P0	ブラケット	BRACKET	1
16	0045000	六角穴ボルト/M5×10	BOLT	2
17	0045020	六角穴ボルト/M5×10	BOLT	1
18	0070810	平ネジ/M6×3.5	SCREW	1
19	2555310	Oリング	O RING	1
20	007020A0	平ネジ/M4×10	SCREW	1
21	2556380	身頃案内	CLOTH GUIDE	1
22	0072530	平ネジ/M4×7	SCREW	2
23	255536-910	吸込管 (組)	SUCTION PIPE ASSEMBLY	1
24	007017A0	平ネジ/M4×5	SCREW	2
25	2555420	ブラケット	BRACKET	1
26	007019A0	平ネジ/M4×8	SCREW	2
27	601110A0	継手	JOINT	1
28	6011150	継手	JOINT	1
29	2555290	軸	SHAFT	1
30	255534-910	下メス台 (組)	LOWER KNIFE HOLDER ASSEMBLY	1
31	2041610	下メス	LOWER KNIFE	1
32	255533-910	下メス押エ (組)	LOWER KNIFE CLAMP ASSEMBLY	1
33	0070820	平ネジ/M4×8	SCREW	1
34	2575730	上メス	UPPER KNIFE	1
35	0070620	平ネジ/M3×6	SCREW	1
36	255545-910	上メス台 (組)	UPPER KNIFE LEVER ASSEMBLY	1
37	0070280	平ネジ/M5×10	SCREW	1
38	257573A0	上メス	UPPER KNIFE	1
39	2555860	軸	SHAFT	1
40	2555710	切屑除ケ	CHIP GUARD	1
41	0070120	平小ネジ/M3.5×6	SCREW	2
42	2555870	切屑受	WASTE CHUTE	1
43	0071430	平ネジ/M4×5.5	SCREW	2
44	2555900	切屑除ケ	CHIP GUARD	1
45	0071560	平ネジ/M2.5×3.4	SCREW	1
46	2555880	ダスターシュート	WASTE CHUTE	1
47	2555890	ラッチ	LATCH	1
48	0049100	木ネジ/5.1	SCREW	1
49	306473-UA0	切屑受	WASTE CHUTE TOP	1
50	0049040	木ネジ/3.5	SCREW	3
51	306474A0	ブラケット/切屑受	BRACKET	1
52	0049050	木ネジ/4.5	SCREW	4
53	009050-9U0	切屑受 (セット)	WASTE CHUTE SET	1
54	205468-UA0	切屑受	WASTE FUNNEL	1
55	205469-UA0	切屑受	WASTE FUNNEL	1
56	0040120	平ネジ/M4×12	SCREW	4
57	3034480	座金	WASHER	4

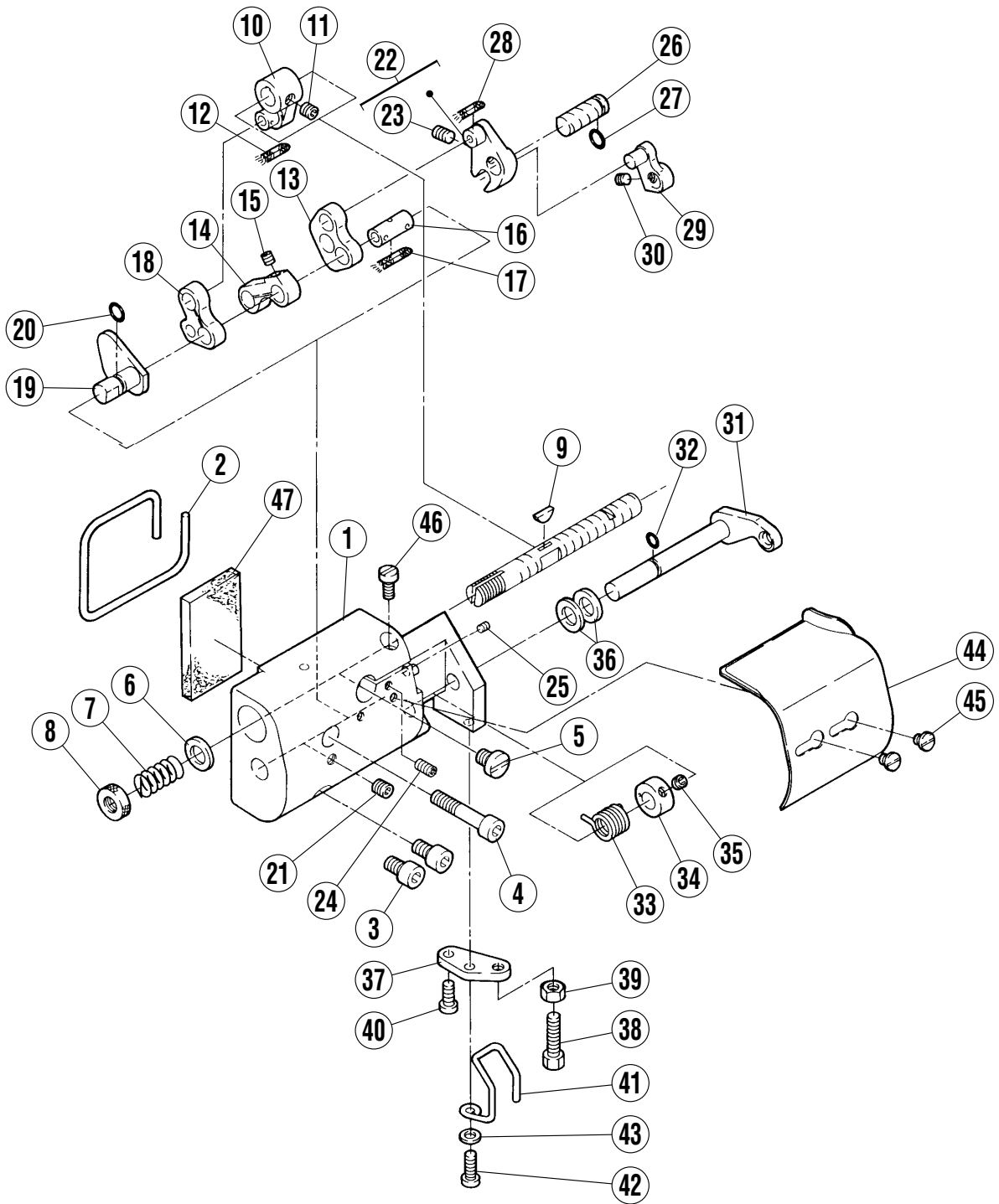



## FT装置(1) [-33]

## FT DEVICE(1) [-33]

REF.NO.	PART NO.	部品名称	DESCRIPTION	QT.
1	255519A9P0	ブラケット	BRACKET	1
2	2555310	Oリング	O RING	1
3	0045000	六角穴ボルト/M5×10	BOLT	2
4	0045020	六角穴ボルト/M5×30	BOLT	1
5	0070810	平ネジ/M6×3.5	SCREW	1
6	2300300	座金	WASHER	1
7	2555480	圧縮バネ	SPRING	1
8	2555460	丸ナット	NUT	1
9	2400080	半月キー	KEY	1
10	255574-910	クランク	CRANK	1
11	0045140	止ネジ/M5×5	SCREW	1
12	2021760	給油紐	OIL STRING	1
13	2555810	リンク (右)	LINK (RIGHT)	1
14	2555790	リンク (中)	LINK (CENTER)	1
15	0045460	止ネジ/M4×5	SCREW	1
16	2555770	軸	SHAFT	1
17	2021760	給油紐	OIL STRING	1
18	2555780	リンク (左)	LINK (LEFT)	1
19	2556030	案内 (左)	GUIDE (LEFT)	1
20	2402510	Oリング	O RING	1
21	0045390	止ネジ/M5×6	SCREW	1
22	255582-920	案内 (右)	GUIDE SHAFT (RIGHT)	1
23	0045390	止ネジ/M5×6	SCREW	1
24	0071810	止ネジ/M4×8	SCREW	1
25	0045350	止ネジ/M3×4	SCREW	1
26	2555830	軸	SHAFT	1
27	2402510	Oリング	O RING	1
28	2021760	給油紐	OIL STRING	1
29	2556040	レバー	LEVER	1
30	0045530	止ネジ/M4×6	SCREW	1
31	2556170	レバー軸	LEVER SHAFT	1
32	2089490	Oリング	O RING	1
33	2556180	ネジリバネ	SPRING	1
34	2556190	カラー	COLLAR	1
35	0045430	止ネジ/M4×4	SCREW	1
36	2102410	座金	WASHER	2
37	2556200	ブラケット	BRACKET	1
38	0045160	六角穴ボルト/M5×20	BOLT	1
39	0048050	六角ナット/M5	NUT	1
40	0070200	平ネジ/M4×10	SCREW	1
41	2556460	フィンガーガード	FINGER GUARD	1
42	0070210	平ネジ/M4×12	SCREW	1
43	3034480	座金	WASHER	1
44	2556380	身頃案内	CLOTH GUIDE	1
45	0072530	平ネジ/M4×7	SCREW	2
46	0070200	平ネジ/M4×10	SCREW	1
47	2556440	スポンジ	SPONGE	1

W664-33A/FT221  
W664-33B/FT222

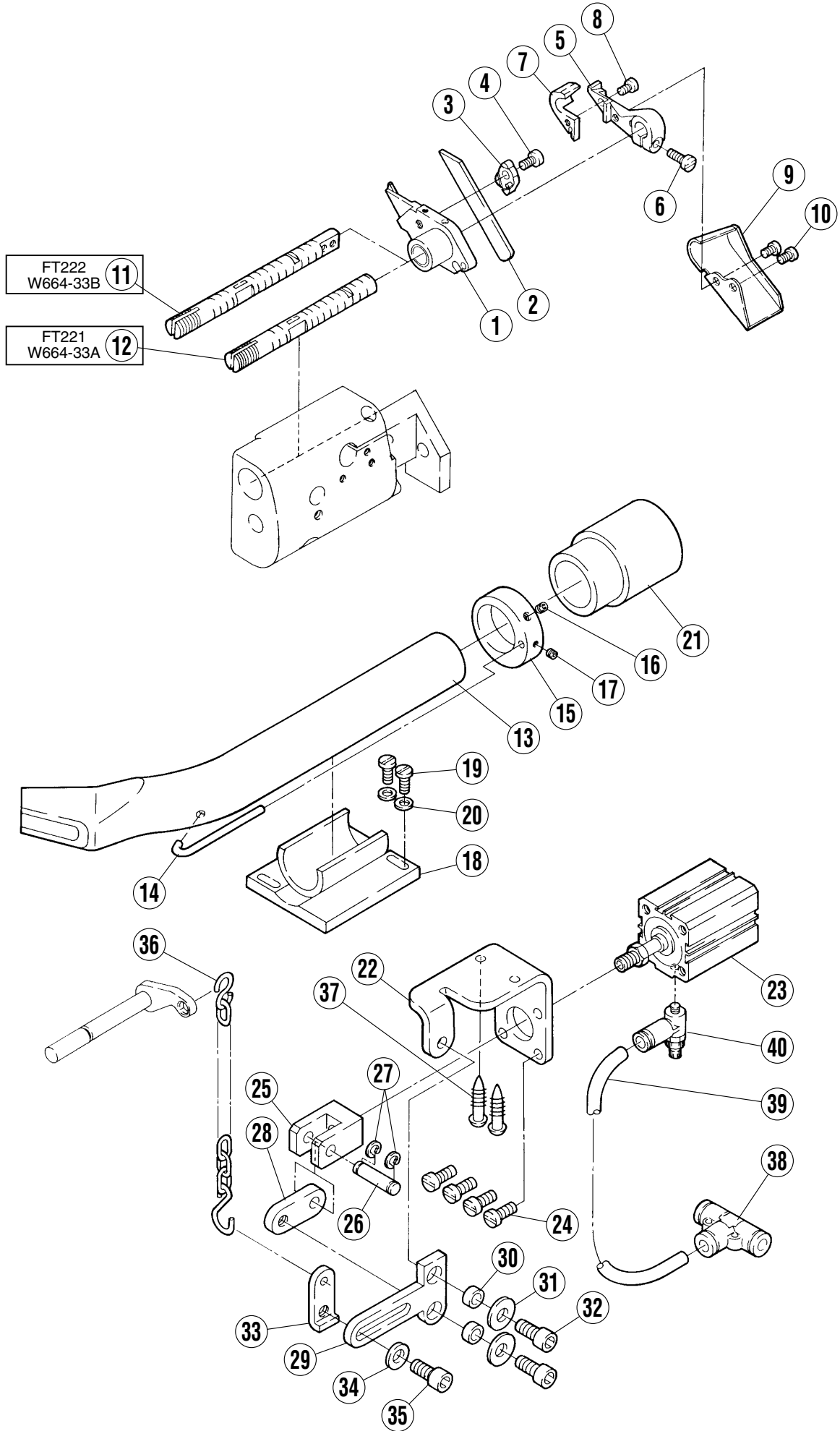

## FT装置(2) [-33]

## FT DEVICE(2) [-33]

REF.NO.	PART NO.	部品名称	DESCRIPTION	QT.
1	255534-910	下メス台 (組)	LOWER KNIFE HOLDER ASSEMBLY	1
2	2041610	下メス	LOWER KNIFE	1
3	255533-910	下メス押エ (組)	LOWER KNIFE CLAMP ASSEMBLY	1
4	0070820	平ネジ/M4×8	SCREW	1
5	255545-910	上メス台 (組)	UPPER KNIFE LEVER ASSEMBLY	1
6	0070280	平ネジ/M5×10	SCREW	1
7	257573A0	上メス	UPPER KNIFE	1
8	0070620	平ネジ/M3×6	SCREW	1
9	255571A0	切屑除ケ	CHIP GUARD	1
10	0070120	平小ネジ/M3.5×6	SCREW	2
11	255586A0	軸	SHAFT	1
12	255529A0	軸	SHAFT	1
13	2556250	吸入管	SUCTION PIPE	1
14	2556400	吹付管	AIR BLOWER	1
15	2556430	ホルダー	HOLDER	1
16	0045380	止ネジ/M4×6	SCREW	1
17	0045540	止ネジ/M3×3	SCREW	1
18	255630-910	パイプホルダー (組)	PIPE HOLDER ASSEMBLY	1
19	0070200	平ネジ/M4×10	SCREW	2
20	3034480	座金	WASHER	2
21	6010470	ゴムカウス	RUBBER CUFF	1
22	3061680	ブラケット	BRACKET	1
23	5110090	エアシリンダ	AIR CYLINDER	1
24	0070290	平ネジ/M5×12	SCREW	4
25	3028320	ナックル	KNUCKLE	1
26	3065870	ピン	PIN	1
27	3030970	止メ輪	RING	2
28	3003860	リンク	LINK	1
29	3003870	レバー	LEVER	1
30	3066760	ローラー	ROLLER	2
31	2040230	座金	WASHER	2
32	0045150	六角穴ボルト/M6×14	BOLT	2
33	3003850	ラッチ	LATCH	1
34	3033350	座金	WASHER	1
35	0045150	六角穴ボルト/M6×14	BOLT	1
36	0003900	鎖	CHAIN	1
37	0049050	木ネジ/4.5	SCREW	2
38	6011200	継手	JOINT	1
39	6001750	チューブ	TUBE	1
40	5260030	ニードルバルブ	VALVE	1

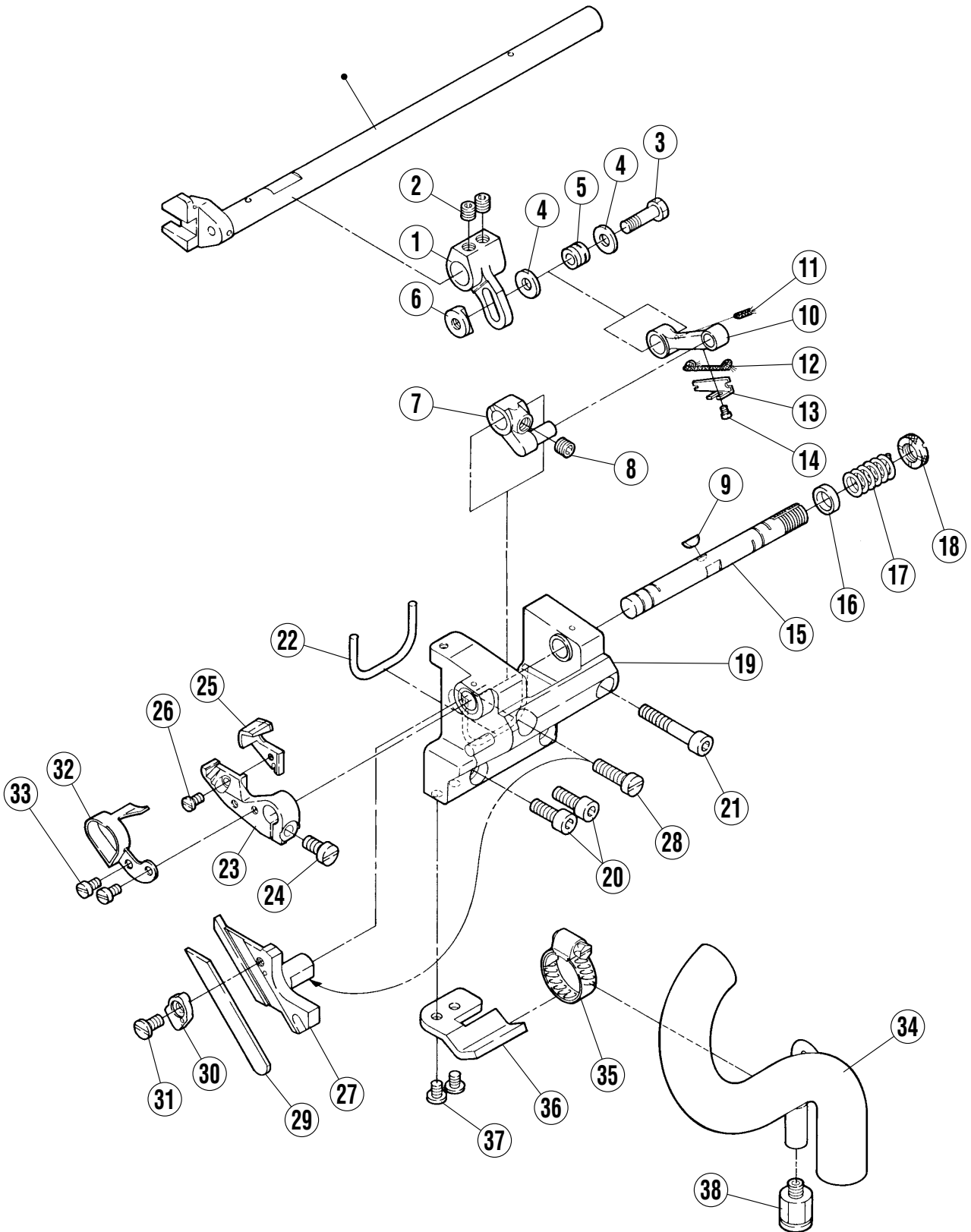

## FT装置 [-34A,35A,35B]

## FT DEVICE [-34A,35A,35B]

REF.NO.	PART NO.	部品名称	DESCRIPTION	QT.
1	2555520	クランク	CRANK	1
2	0045470	止ネジ/M6×5	SCREW	2
3	0070570	六角ネジ/M5×17	SCREW	1
4	2400390	座金	WASHER	1
5	179160-050	ブッシュ	BUSHING	1
6	2555530	ナット	NUT	1
7	2555540	クランク	CRANK	1
8	0045470	止ネジ/M6×5	SCREW	1
9	2400080	半月キー	KEY	1
10	252557A0	リンク	LINK	1
11	2021740	給油紐	OIL STRING	1
12	2021750	給油紐	OIL STRING	1
13	2550770	ラッチ	LATCH	1
14	0070610	平ネジ/M2×2.7	SCREW	1
15	2555550	軸	SHAFT	1
16	2300300	座金	WASHER	1
17	2555480	圧縮バネ	SPRING	1
18	2555460	丸ナット	NUT	1
19	255549-9P0	ブラケット (組)	BRACKET ASSEMBLY	1
20	0045010	六角穴ボルト/M5×14	BOLT	2
21	0045020	六角穴ボルト/M5×30	BOLT	1
22	2555570	ガスケット	GASKET	1
23	255564-910	上メス台 (組)	UPPER KNIFE HOLDER ASSEMBLY	1
24	0070280	平ネジ/M5×10	SCREW	1
25	2575740	上メス	UPPER KNIFE	1
26	0070620	平ネジ/M3×6	SCREW	1
27	2555600	下メス台	LOWER KNIFE HOLDER	1
28	0070300	平小ネジ/M5×18	SCREW	1
29	204161A0	下メス	LOWER KNIFE	1
30	255558-910	下メス押エ (組)	LOWER KNIFE CLAMP ASSEMBLY	1
31	0070820	平ネジ/M4×8	SCREW	1
32	2556150	切屑受	WASTE CHUTE TOP	1
33	0070120	平小ネジ/M3.5×6	SCREW	2
34	255567-910	吸込管 (組)	SUCTION PIPE ASSEMBLY	1
35	6080050	ホースバンド	HOSE BAND	1
36	2555620	ラッチ	LATCH	1
37	0071430	平ネジ/M4×5.5	SCREW	2
38	6011150	継手	JOINT	1

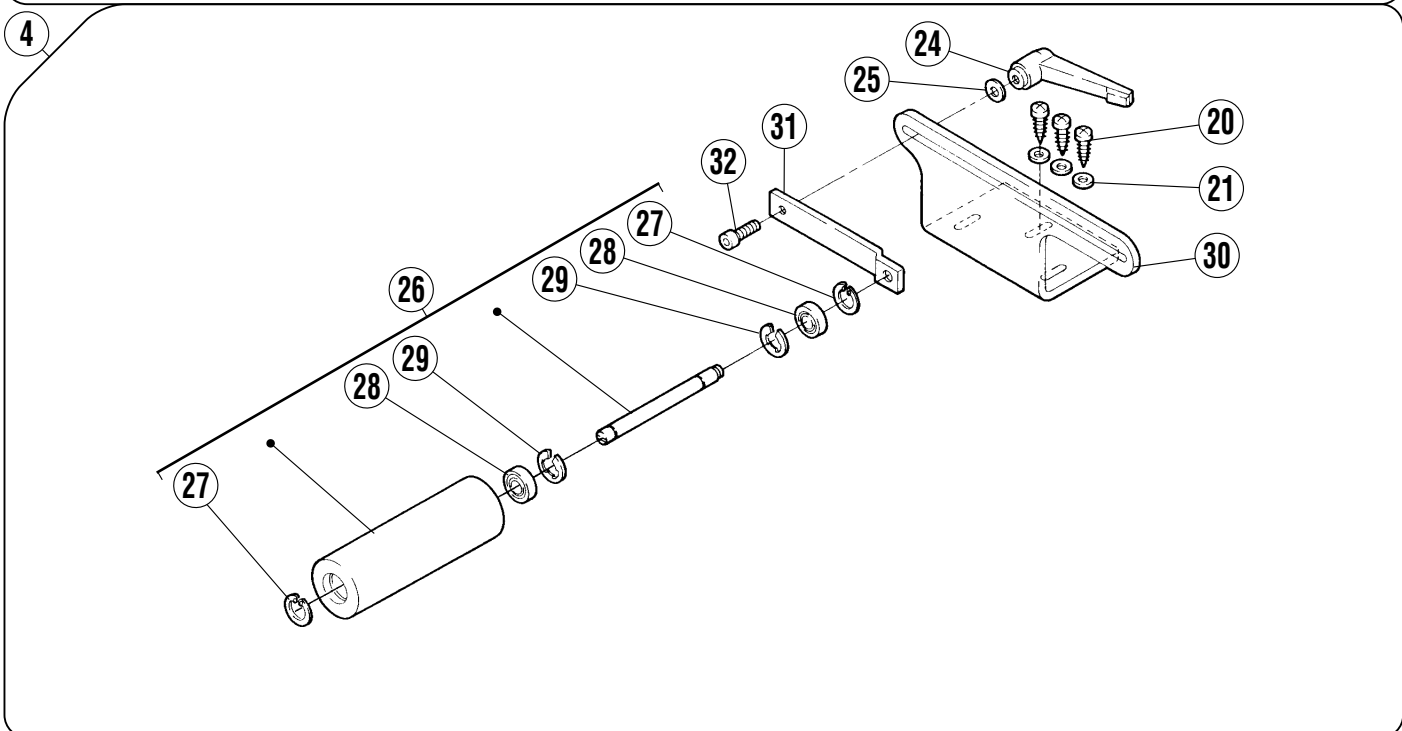
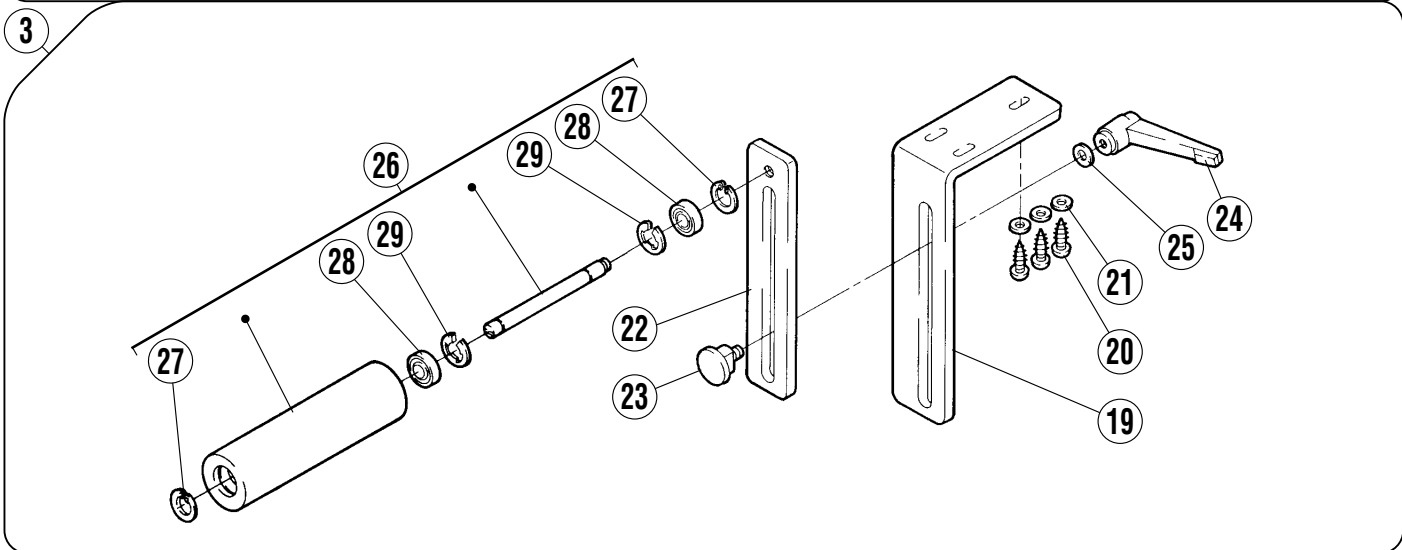
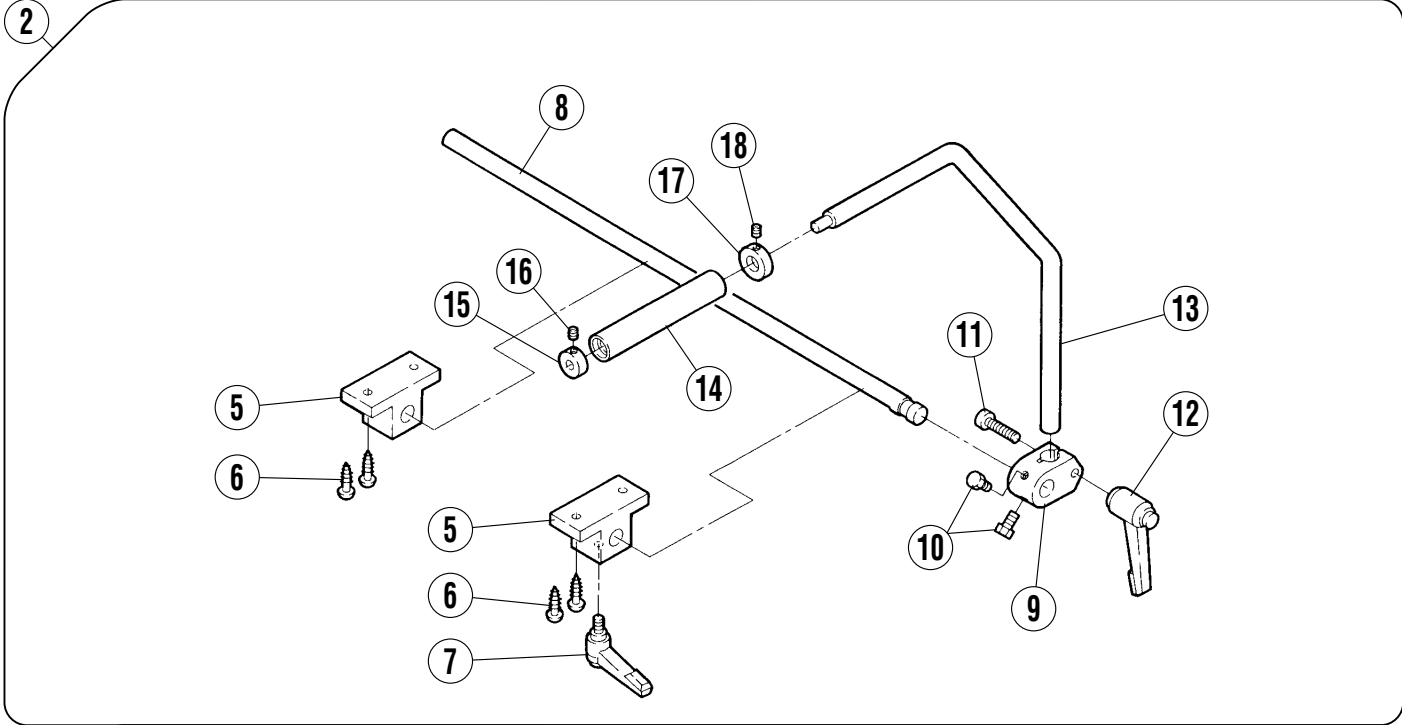

布張りローラー装置(1) [-30,34A]

FABRIC TENSIONER DEVICE(1) [-30,34A]

REF.NO.	PART NO.	部品名称	DESCRIPTION	QT.
1	259026-910	布張りローラー装置 (組)	FABRIC TENSIONER DEVICE	1
2	259021-910	前ローラー装置 (組)	FRONT ROLLER ASSEMBLY	1
3	259022-910	下ローラー装置 (組)	LOWER ROLLER ASSEMBLY	1
4	259023-910	後ローラー装置 (組)	REAR ROLLER ASSEMBLY	1
5	2590040	ブラケット	BRACKET	1
6	0049050	木ネジ/4.5	SCREW	2
7	3506220	クランプレバー	CLAMP LEVER	1
8	2590050	軸	SHAFT	1
9	2590060	継手	JOINT	1
10	0070680	六角ネジ/M5×10	SCREW	2
11	0045110	六角穴ボルト/M6×25	BOLT	1
12	259015A0	クランプレバー	CLAMP LEVER	1
13	2590120	軸	SHAFT	1
14	2590130	ローラー	ROLLER	1
15	2590200	カラー	COLLAR	1
16	0045430	止ネジ/M4×4	SCREW	1
17	2590140	カラー	COLLAR	1
18	0045430	止ネジ/M4×4	SCREW	1
19	2590070	ブラケット	BRACKET	1
20	0049050	木ネジ/4.5	SCREW	3
21	1371420	座金	WASHER	3
22	3068290	案内板	GUIDE PLATE	1
23	306830B0	締付金具	SCREW	1
24	259015A0	クランプレバー	CLAMP LEVER	1
25	2040230	座金	WASHER	1
26	259018-910	ローラー (組)	ROLLER ASSEMBLY	1
27	2402500	止メ輪	RING	2
28	2402490	ボールベアリング	BALL BEARING	2
29	2050610	止メ輪	RING	2
30	2590100	ブラケット	BRACKET	1
31	2590110	ブラケット	BRACKET	1
32	0045030	六角穴ボルト/M6×20	BOLT	1

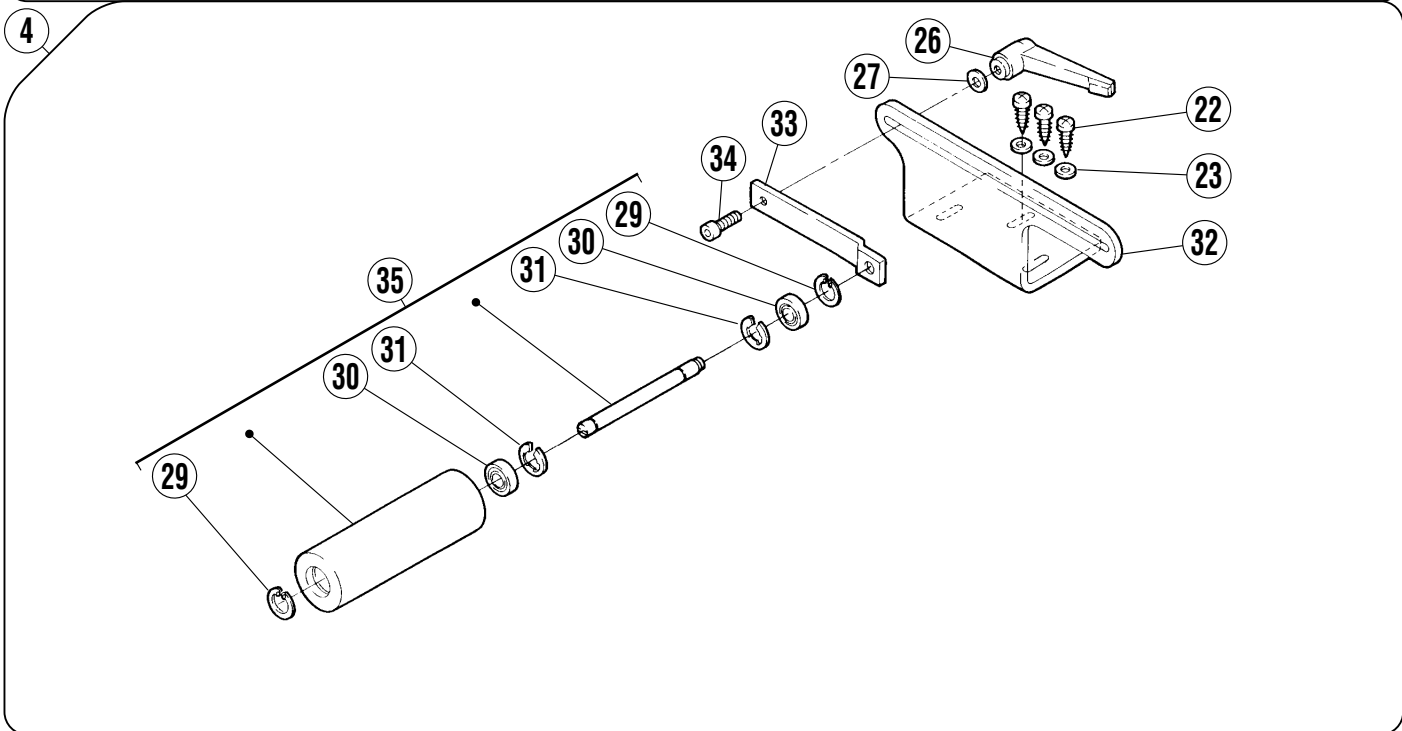
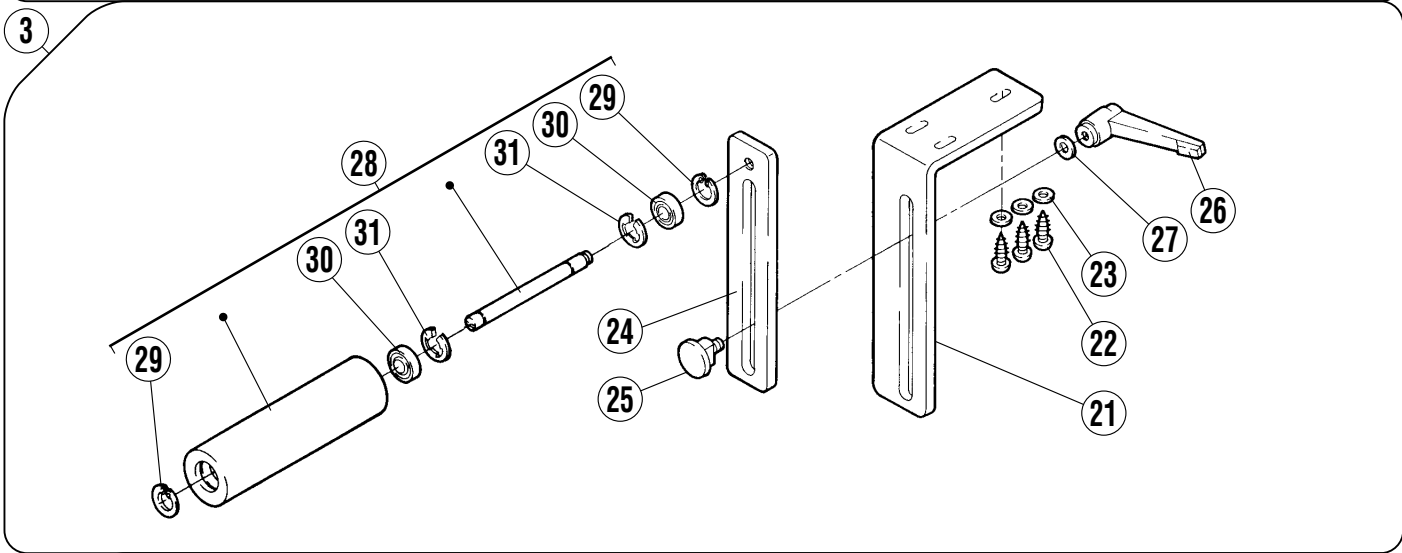
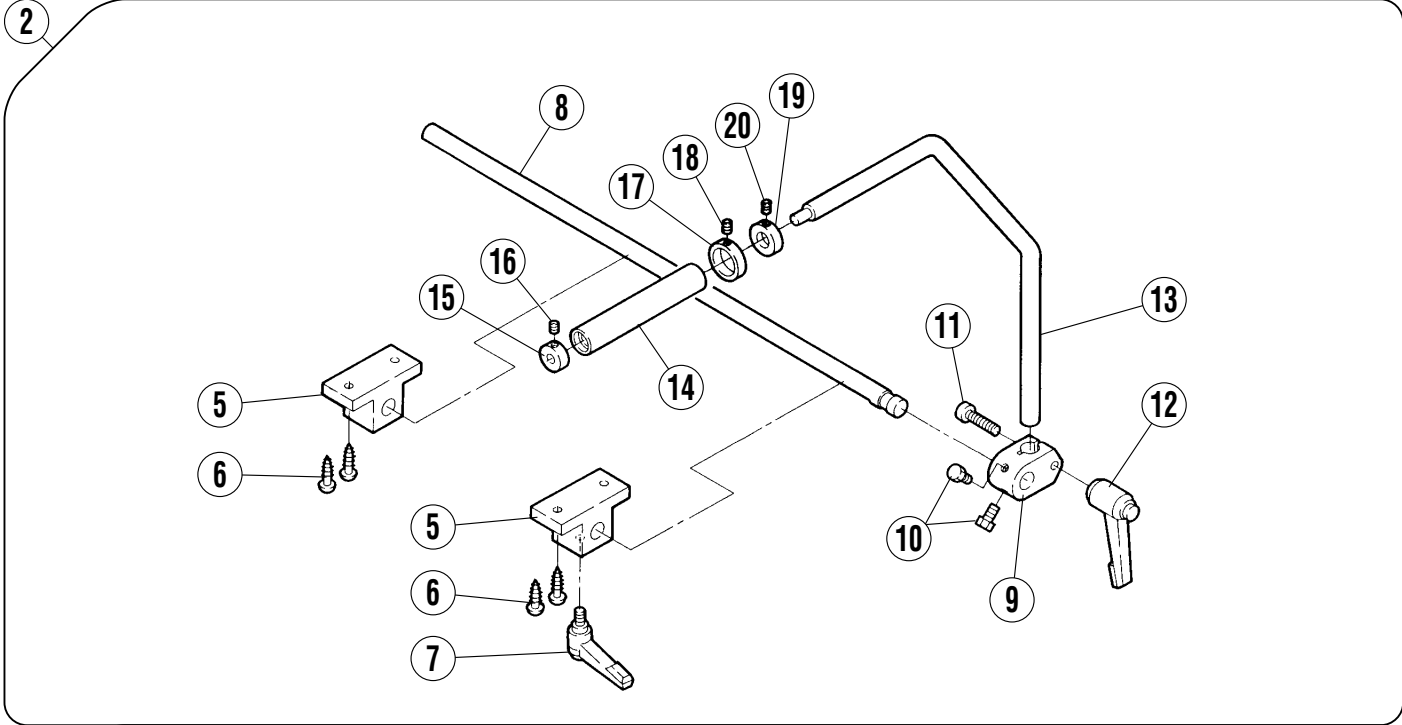



布張りローラー装置(2) [-32]

FABRIC TENSIONER DEVICE(2) [-32]

REF.NO.	PART NO.	部品名称	DESCRIPTION	QT.
1	259026A910	布張りローラー装置 (組)	FABRIC TENSIONER DEVICE	1
2	259021A910	前ローラー装置 (組)	FRONT ROLLER ASSEMBLY	1
3	259022A910	下ローラー装置 (組)	LOWER ROLLER ASSEMBLY	1
4	259023-910	後ローラー装置 (組)	REAR ROLLER ASSEMBLY	1
5	2590040	ブラケット	BRACKET	1
6	0049050	木ネジ/4.5	SCREW	2
7	3506220	クランプレバー	CLAMP LEVER	1
8	2590050	軸	SHAFT	1
9	2590060	継手	JOINT	1
10	0070680	六角ネジ/M5×10	SCREW	2
11	0045110	六角穴ボルト/M6×25	BOLT	1
12	259015A0	クランプレバー	CLAMP LEVER	1
13	2590120	軸	SHAFT	1
14	2590130	ローラー	ROLLER	1
15	2590200	カラー	COLLAR	1
16	0045430	止ネジ/M4×4	SCREW	1
17	2590280	カラー	COLLAR	1
18	0045540	止ネジ/M3×3	SCREW	1
19	2590070	ブラケット	BRACKET	1
20	0045430	止ネジ/M4×4	SCREW	1
21	2590070	ブラケット	BRACKET	1
22	0049050	木ネジ/4.5	SCREW	3
23	1371420	座金	WASHER	3
24	3068290	案内板	GUIDE PLATE	1
25	306830B0	締付金具	SCREW	1
26	259015A0	クランプレバー	CLAMP LEVER	1
27	2040230	座金	WASHER	1
28	259018A911	ローラー (組)	ROLLER ASSEMBLY	1
29	2402500	止メ輪	RING	2
30	2402490	ボールベアリング	BALL BEARING	2
31	2050610	止メ輪	RING	2
32	2590100	ブラケット	BRACKET	1
33	2590110	ブラケット	BRACKET	1
34	0045030	六角穴ボルト/M6×20	BOLT	1
35	259018-910	ローラー (組)	ROLLER ASSEMBLY	1

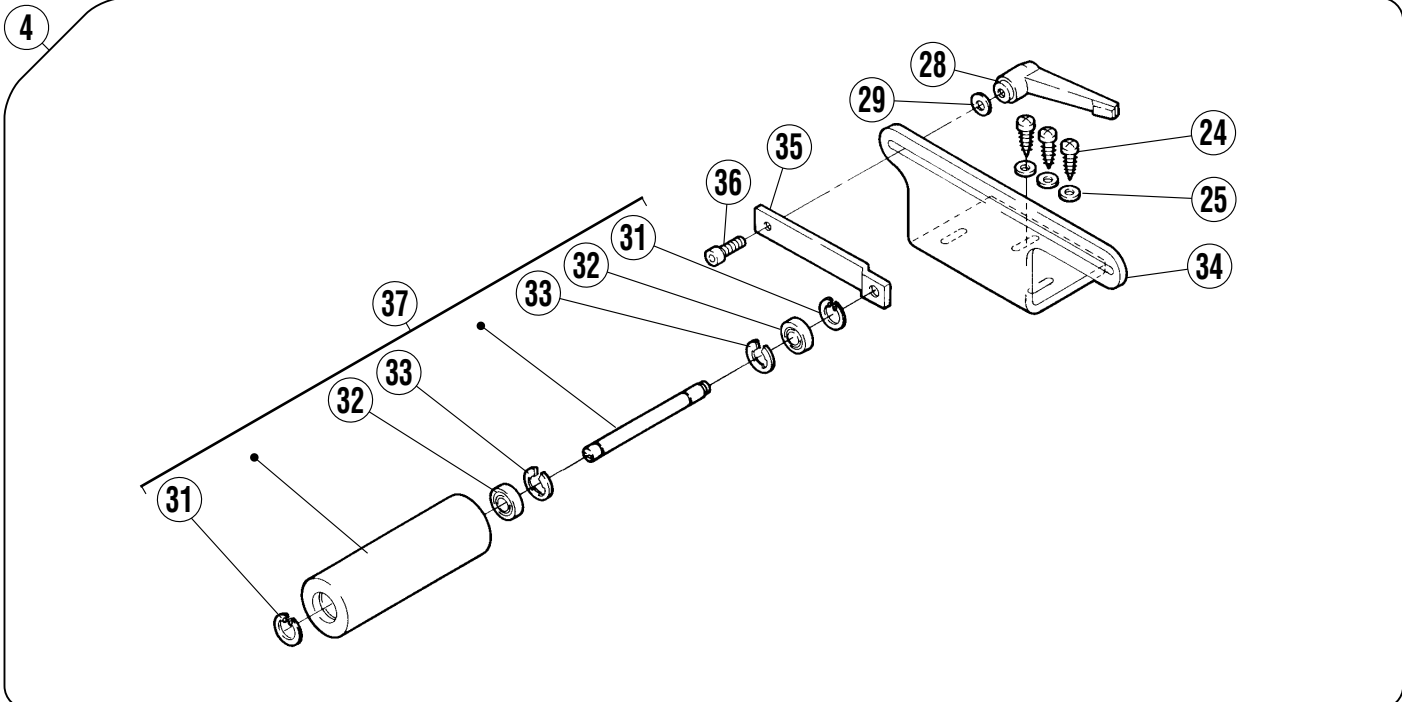
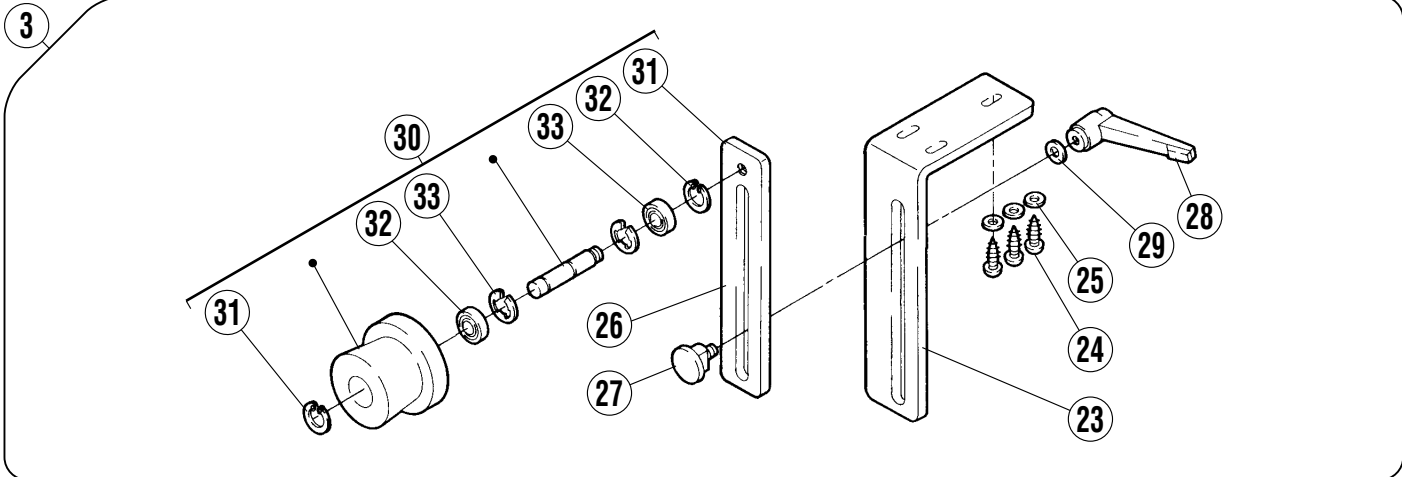
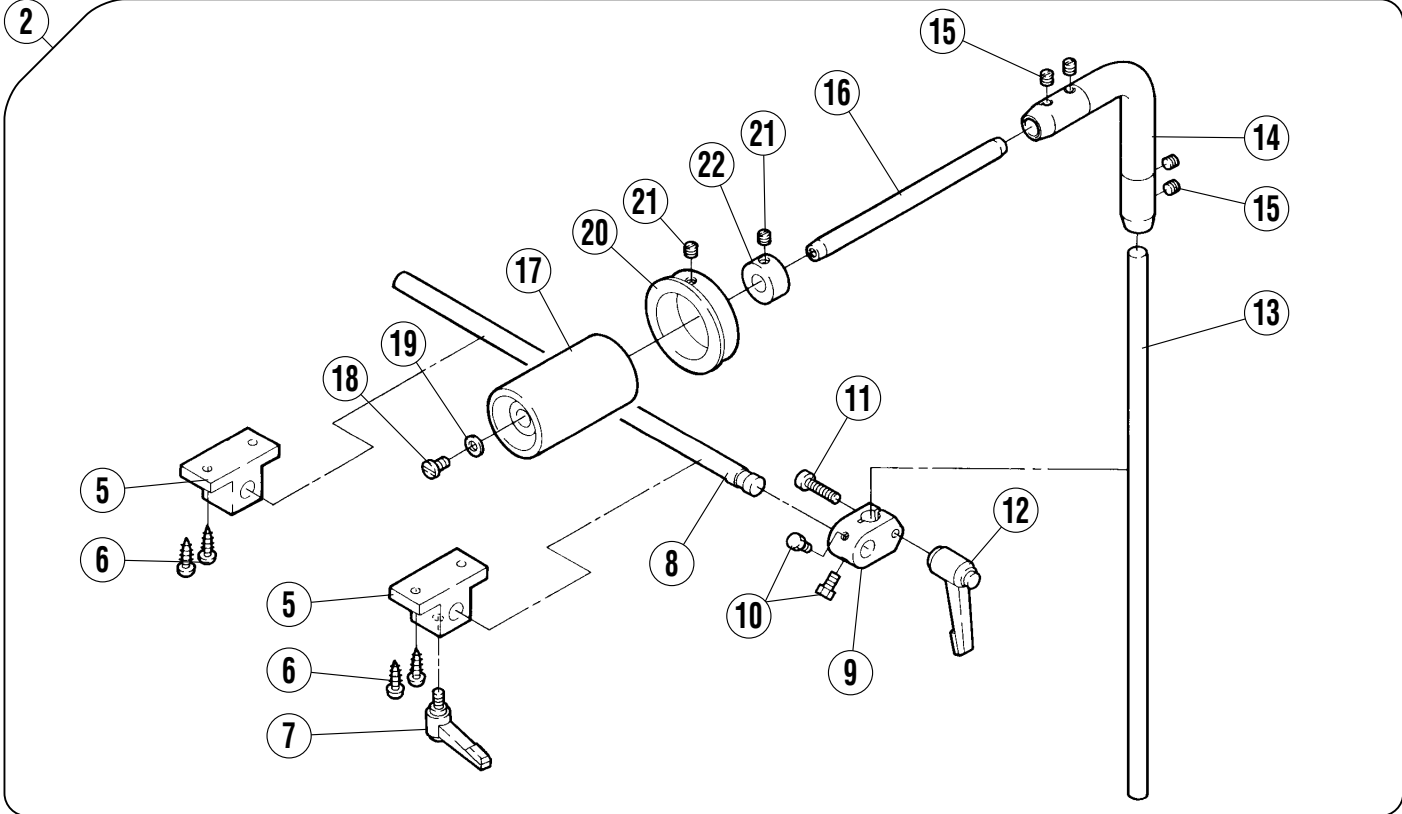

## 布張りローラー装置(3) [-33]

## FABRIC TENSIONER DEVICE(3) [-33]

REF.NO.	PART NO.	部品名称	DESCRIPTION	QT.
1	259027-910	布張りローラー装置 (組)	FABRIC TENSIONER DEVICE	1
2	259024-910	前ローラー装置 (組)	FRONT ROLLER ASSEMBLY	1
3	259025-910	下ローラー装置 (組)	LOWER ROLLER ASSEMBLY	1
4	259023-910	後ローラー装置 (組)	REAR ROLLER ASSEMBLY	1
5	2590040	ブラケット	BRACKET	1
6	0049050	木ネジ/4.5	SCREW	2
7	3506220	クランプレバー	CLAMP LEVER	1
8	259005A0	軸	SHAFT	1
9	2590060	継手	JOINT	1
10	0070680	六角ネジ/M5×10	SCREW	2
11	0045110	六角穴ボルト/M6×25	BOLT	1
12	259015A0	クランプレバー	CLAMP LEVER	1
13	3068230	軸	SHAFT	1
14	3068380	ブラケット	BRACKET	1
15	002913-10	止ネジ/C10×4.5	SCREW	4
16	2590170	軸	SHAFT	1
17	3070250	ローラー	ROLLER	1
18	0070520	平ネジ/M6×10	SCREW	1
19	2045200	座金	WASHER	1
20	3070260	身頃案内	CLOTH GUIDE	1
21	0020220	止ネジ/C10×5.5	SCREW	2
22	3068430	カラー	COLLAR	1
23	2590070	ブラケット	BRACKET	1
24	0049050	木ネジ/4.5	SCREW	3
25	1371420	座金	WASHER	3
26	3068290	案内板	GUIDE PLATE	1
27	306830B0	締付金具	SCREW	1
28	259015A0	クランプレバー	CLAMP LEVER	1
29	2040230	座金	WASHER	1
30	259019-910	ローラー (組)	ROLLER ASSEMBLY	1
31	2402500	止メ輪	RING	2
32	2402490	ボールベアリング	BALL BEARING	2
33	2050610	止メ輪	RING	2
34	2590100	ブラケット	BRACKET	1
35	2590110	ブラケット	BRACKET	1
36	0045030	六角穴ボルト/M6×20	BOLT	1
37	259018-910	ローラー (組)	ROLLER ASSEMBLY	1

W664-33A

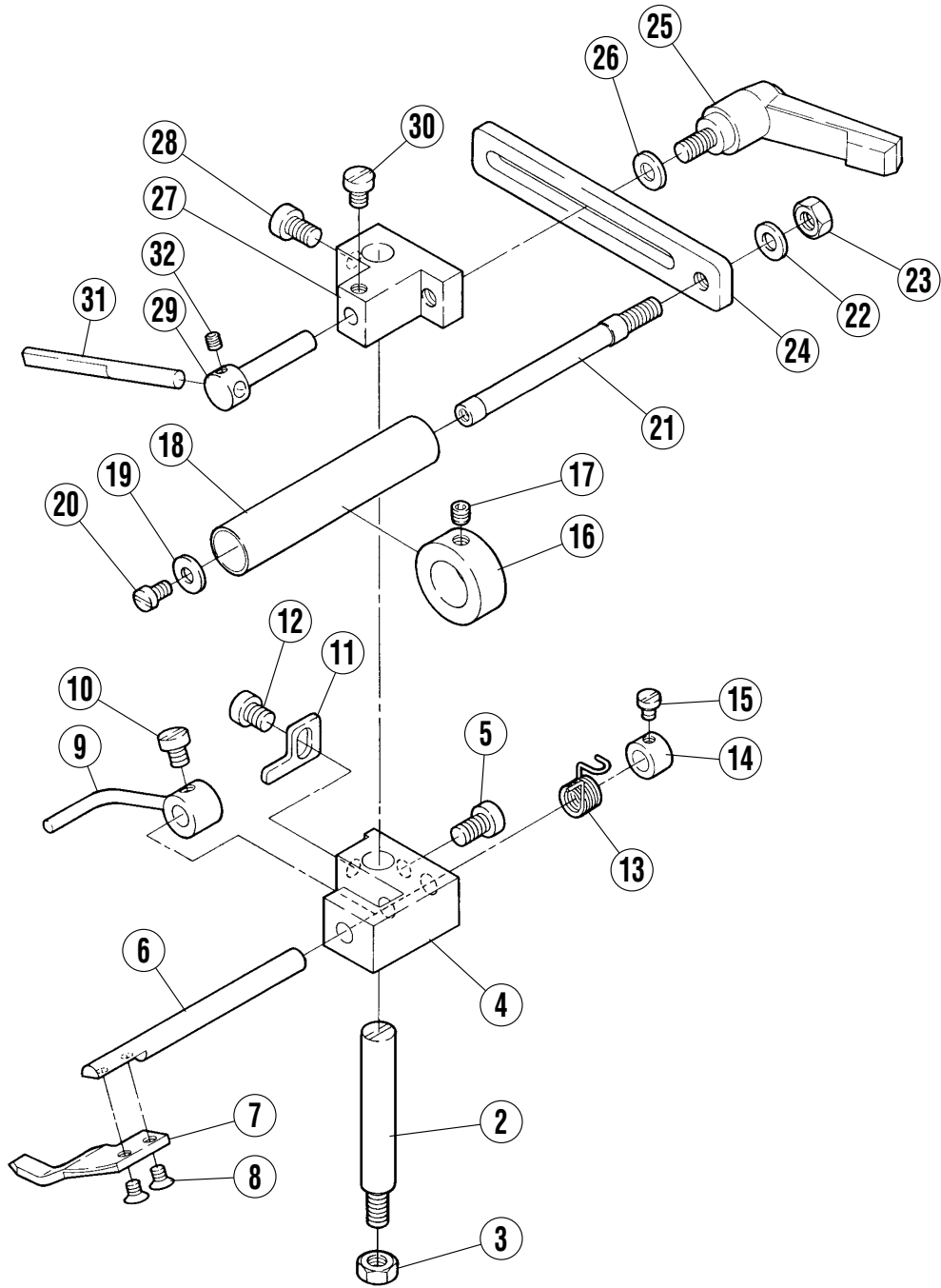

W664-33B

附属品に梱入  
Packed in accessory

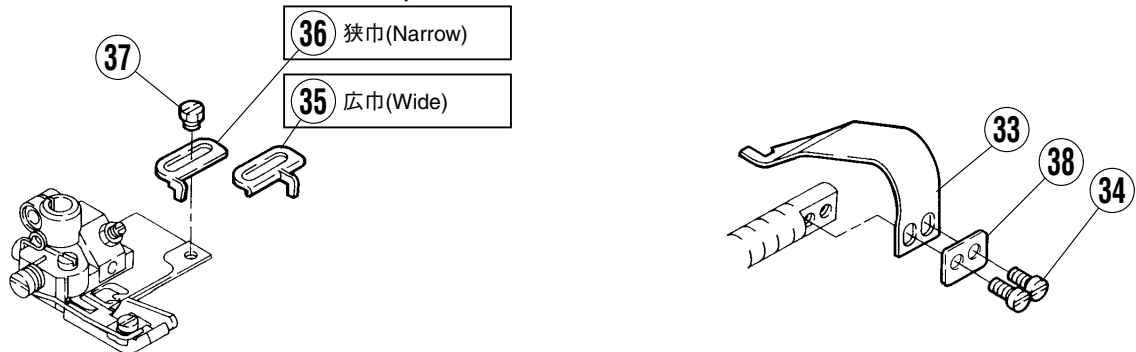

ゴム付装置 [-33]

ELASTIC ATTACHING DEVICE [-33]

REF.NO.	PART NO.	部品名称	DESCRIPTION	QT.
1	258045-910	ゴム付ケ装置 (組)	ELASTIC ATTACHING DEVICE	1
2	2580310	段付ネジ/M5	SCREW	1
3	0048200	六角ナット/M5	NUT	1
4	2580320	ブラケット	BRACKET	1
5	0070270	平ネジ/M5×8	SCREW	1
6	2580380	軸	SHAFT	1
7	2580370	ブレード	BLADE	1
8	0070400	皿ネジ/M3×4	SCREW	2
9	258039-910	レバー (組)	LEVER ASSEMBLY	1
10	0070170	平ネジ/M4×5	SCREW	1
11	2580360	ストッパー	STOPPER	1
12	0070790	平ネジ/M5×6	SCREW	1
13	2580410	線細工バネ	SPRING	1
14	2402660	カラー	COLLAR	1
15	0070080	平ネジ/M3×4	SCREW	1
16	2402670	カラー	COLLAR	1
17	0045430	止ネジ/M4×4	SCREW	1
18	2580440	ローラー	ROLLER	1
19	1670660	座金	WASHER	1
20	0070120	平小ネジ/M3.5×6	SCREW	1
21	2580430	軸	SHAFT	1
22	2045850	座金	WASHER	1
23	0048050	六角ナット/M5	NUT	1
24	2580420	ブラケット	BRACKET	1
25	2590150	クランプレバー	CLAMP LEVER	1
26	2045850	座金	WASHER	1
27	2580350	ブラケット	BRACKET	1
28	0070270	平ネジ/M5×8	SCREW	1
29	2580340	ホルダー	HOLDER	1
30	0070180	平ネジ/M4×6	SCREW	1
31	2580330	ゴム案内	ELASTIC GUIDE	1
32	0045540	止ネジ/M3×3	SCREW	1
33	3070230	ブレード	BLADE	1
34	0071680	止ネジ/M3.5×6.5	SCREW	2
35	3070190	ゴムガイド	ELASTIC GUIDE	1
36	3070180	ゴムガイド	ELASTIC GUIDE	1
37	0056310	六角ボルト	BOLT	1
38	2405880	座金	WASHER	1

※86頁参照。Refer to page 86.

形式名	ローラー表面	材質	適用機種名(標準装備機種名)
DEVICE TYPE	ROLLER SURFACE	MATERIAL	APPLICABLE MODELS (STANDARD EQUIPMENT)
RP110A	フラット Flat	ウレタンゴム Urethane rubber	W664-32AB,32AC,33AB,33BB
RP113A	ギヤ Gear (70°)	ナイロン Nylon	W664-30AB,30AC,33AB,33BB, 34AB,34AC,81AB,81AC
RP113B	ギヤ Gear (90°)	〃	Option

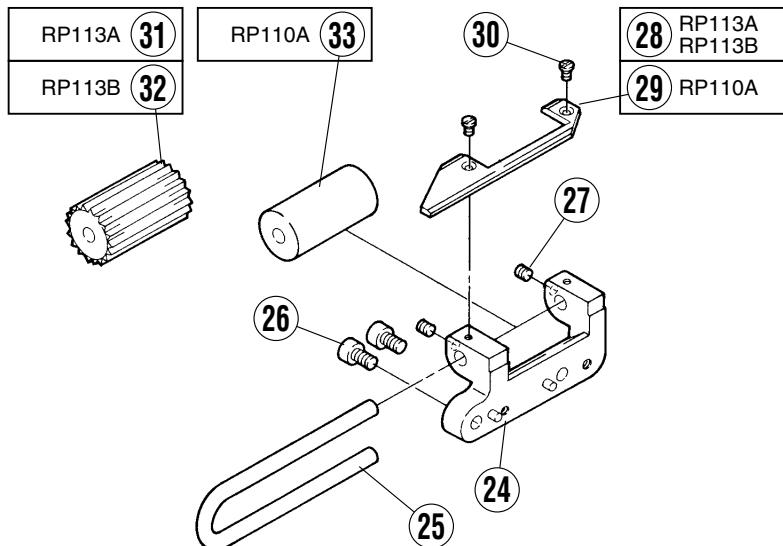
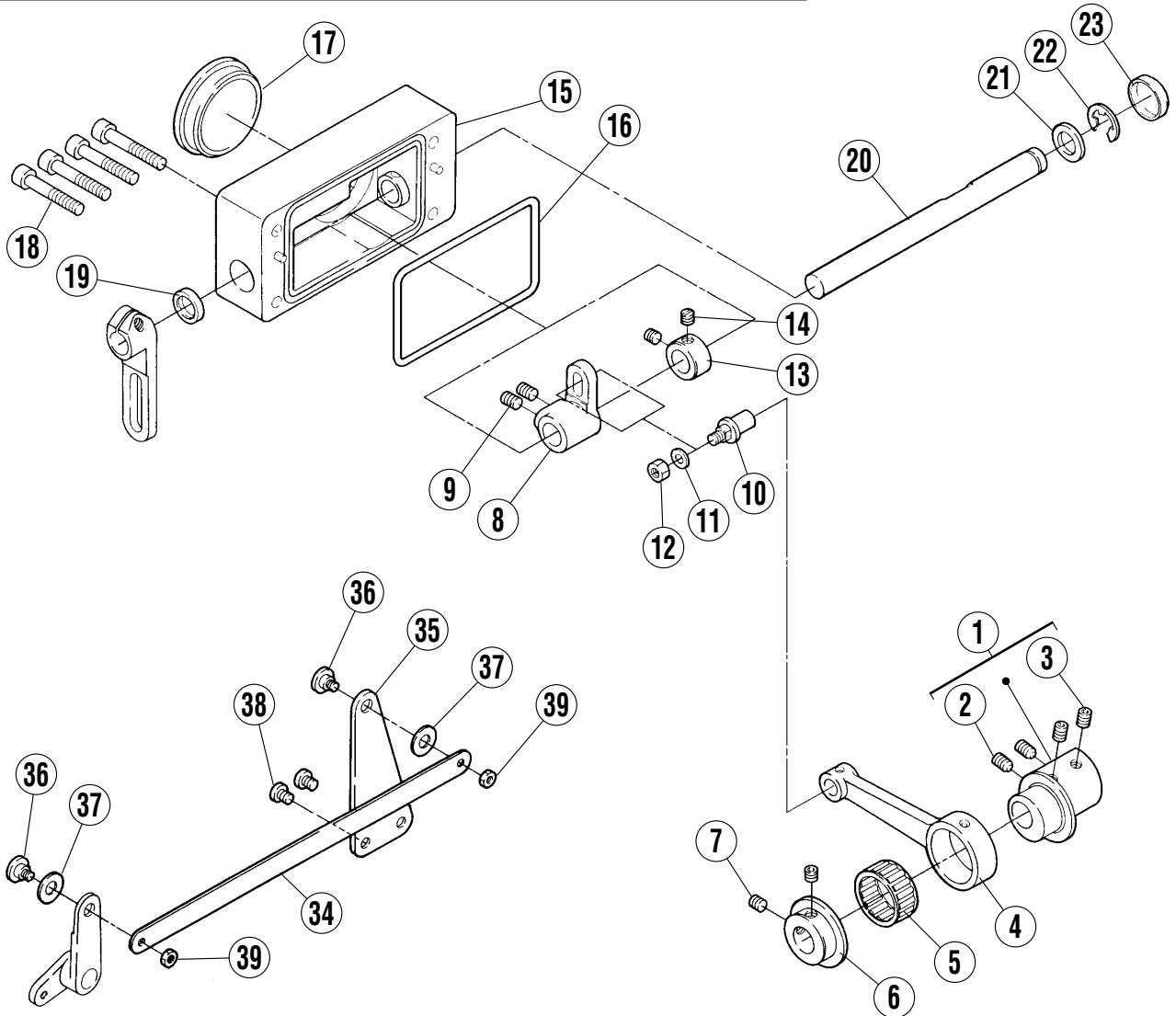

## RP装置(1)

## RP DEVICE(1)

REF.NO.	PART NO.	部品名称	DESCRIPTION	QT.
1	256500-920	エキセン	ECCENTRIC	1
2	0045550	止ネジ/M6×8	SCREW	2
3	0045480	止ネジ/M6×8	SCREW	2
4	2565010	ロッド	CONNECTION	1
5	240236-20	ニードルベアリング	NEEDLE BEARING	1
6	2565020	カラー	COLLAR	1
7	0045470	止ネジ/M6×5	SCREW	2
8	2565030	クランク	CRANK	1
9	0045480	止ネジ/M6×8	SCREW	2
10	2545040	ピン付ネジ/M5	SCREW	1
11	2400620	座金	WASHER	1
12	0048050	六角ナット/M5	NUT	1
13	2016350	カラー	COLLAR	1
14	0050600	止ネジ/C8×4.5	SCREW	2
15	256504-9P0	ブラケット (組)	BRACKET ASSEMBLY	1
16	2565070	Oリング	O RING	1
17	2565080	栓	PLUG	1
18	0045230	六角穴ボルト/M6×35	BOLT	4
19	2100690	オイルシール	OIL SEAL	1
20	2565090	軸	SHAFT	1
21	2061800	座金	WASHER	1
22	3066710	止メ輪	RING	1
23	2112470	栓	PLUG	1
24	256536-9P0	ブラケット (組)	BRACKET ASSEMBLY	1
25	2565450	案内棒	GUIDE BAR	1
26	0045180	六角穴ボルト/M6×10	BOLT	2
27	0045140	止ネジ/M5×5	SCREW	2
28	2565460	カバー	COVER	1
29	2565470	カバー	COVER	1
30	0070620	平ネジ/M3×6	SCREW	2
31	2565400	ギヤローラー (下)	LOWER TOOTHED ROLLER	1
32	2565410	ギヤローラー (下)	LOWER TOOTHED ROLLER	1
33	2565440	ローラー (下)	LOWER ROLLER	1
34	2565220	連結板	CONNECTING PLATE	1
35	2565230	レバー	LEVER	1
36	0071410	段付ネジ/M4	SCREW	2
37	3067890	防振ゴム	CUSHION RUBBER	2
38	0070790	平ネジ/M5×6	SCREW	2
39	0048210	六角ナット/M4	NUT	2

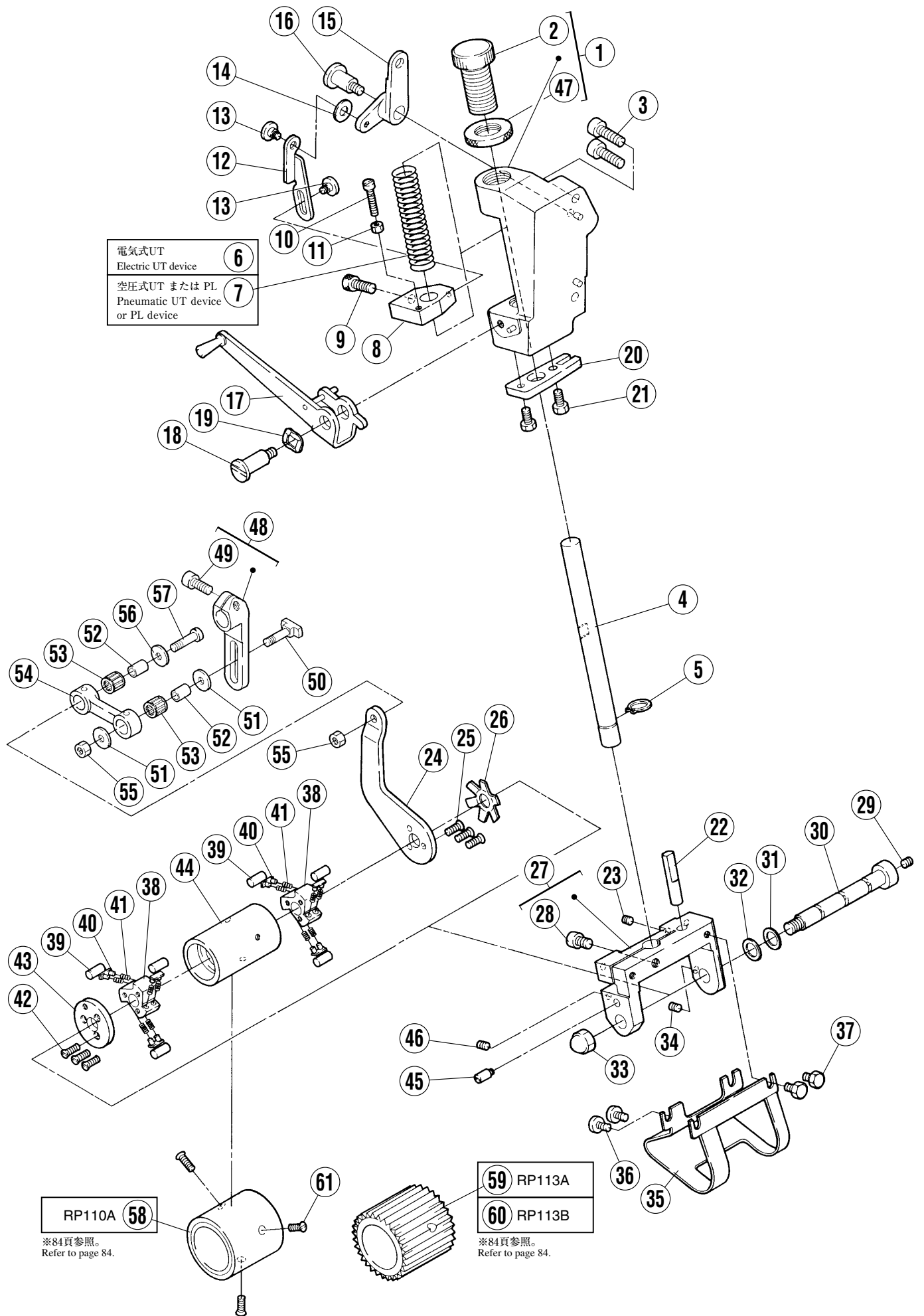



## RP装置(2)

## RP DEVICE(2)

REF.NO.	PART NO.	部品名称	DESCRIPTION	QT.
1	256510-9P0	ブラケット (組)	BRACKET ASSEMBLY	1
2	2565120	調節ネジ	SCREW	1
3	0045030	六角穴ボルト/M6×20	BOLT	2
4	2565180	軸	SHAFT	1
5	2029010	止メ輪	RING	1
6	2402570	圧縮バネ	SPRING	1
7	240257A0	圧縮バネ	SPRING	1
8	2565170	ブラケット	BRACKET	1
9	0045100	六角穴ボルト/M6×16	BOLT	1
10	007025A0	平ネジ/M4×20	SCREW	1
11	0048210	六角ナット/M4	NUT	1
12	2565190	リンク	LINK	1
13	0070660	段付ネジ/M4	SCREW	2
14	3067890	防振ゴム	CUSHION RUBBER	1
15	2565200	レバー	LEVER	1
16	2565210	段付ネジ	SCREW	1
17	256524-910	レバー	LEVER	1
18	2565270	段付ネジ	SCREW	1
19	2402580	波板座金	WASHER	1
20	256529A0	案内板	GUIDE PLATE	1
21	0070680	六角ネジ/M5×10	SCREW	2
22	256530A0	軸	SHAFT	1
23	0045140	止ネジ/M5×5	SCREW	1
24	2565310	クランク	CRANK	1
25	0070830	皿ネジ/M4×10	SCREW	3
26	2565330	板バネ	FLAT SPRING	1
27	256528-920	ブラケット	BRACKET	1
28	0045100	六角穴ボルト/M6×16	BOLT	1
29	0045390	止ネジ/M5×6	SCREW	1
30	2565320	軸	SHAFT	1
31	2402590	座金	WASHER	1
32	2401020	座金	WASHER	1
33	0071400	Uナット/M8	NUT	1
34	0045680	止ネジ/M5×8	SCREW	1
35	2565480	カバー	COVER	1
36	0070740	平ネジ/M5×5	SCREW	2
37	0070680	六角ネジ/M5×10	SCREW	2
38	2560120	クラッチ	CLUTCH	2
39	3065000	平行ピン	PIN	6
40	3062430	案内板	GUIDE PLATE	6
41	240114A0	圧縮バネ	SPRING	12
42	0070830	皿ネジ/M4×10	SCREW	3
43	2565350	クラッチ板	CLUTCH PLATE	1
44	256550-910	スリーブ (組)	SLEEVE ASSEMBLY	1
45	0071390	ピン付ネジ/M4	SCREW	1
46	0045390	止ネジ/M5×6	SCREW	1
47	2565580	丸ナット/M20	NUT	1
48	256513-920	クランク	CRANK	1
49	0045340	六角穴ボルト/M6×14	BOLT	1
50	2565140	段付ピン	PIN	1
51	1374410	座金	WASHER	2
52	2565150	ブッシュ	BUSHING	2
53	240011-20	ニードルベアリング	NEEDLE BEARING	2
54	2565160	リンク	LINK	1
55	0048050	六角ナット/M5	NUT	2
56	1374410	座金	WASHER	1
57	0071380	六角ボルト/M5×20	BOLT	1
58	2565430	ローラー (上)	UPPER ROLLER	1
59	2565380	ギヤローラー (上)	UPPER TOOTHED ROLLER	1
60	2565390	ギヤローラー (上)	UPPER TOOTHED ROLLER	1
61	0070830	皿ネジ/M4×10	SCREW	3

W600ゲージパーツ表(1)

W600 GAUGE PARTS LIST(1)

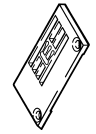

マシン形式 MACHINE TYPE /SPEC	ゲージ GAUGE	針留 NEEDLE HOLDER	針板 NEEDLE PLATE	主送り歯 MAIN FEED DOG	差動送り歯 DIFF.FEED DOG	押エ PRESSER FOOT	ルーバー LOOPER	針受け(前)		針受け(後)	スプレッダー SPREADER	針 NEEDLE
								FRONT	REAR			
W664-01EB	356	257542-561	257128B560	257243-16F1	257298-16F0	257472-560	2575660	2575680	2575670	2575650	UY128GAS #10S	
	232	257541-321	257015B320			257471-320						
	240	401	B400	257242-16F1	257289-16F0	400						
	248	481	B480			480	2575660	2575680	2575670	2575650	UY128GAS #9S	
	356	257542-561	257018B560	257243-16F1	257290-16F0	257472-560					UY128GAS #10S	
W664-01HB	364	641	B640			640						
	356	257542-561	259620B560	257242-16F1	257289-16F0	257472-560	2575660	2575680	2575670	2575650	UY128GAS #10S	
	356	257542-561	257192C563	257243-16F1	257290-16F0	257472-560	2575660	2575680	2575670	2575650	UY128GAS #10S	
	364	641	C641			640						
	232	257541-321	259628B320	259152-16F0	259267-16F0	257317A320						
W664-02GB	240	401	259629B400	259153-16F0	259268-16F0	257318A400						
	248	481	B480			A480	2575660	2575680	2575670	2575650	UY128GAS #9S	
	356	257542-561	259632B560	259154-16F0	259269-16F0	257321A560					UY128GAS #10S	
	364	641	B640			A640						
	232	257541-321	257098B320	257242-16F1		257467-320						
W664-03FB W664-03LB	240	401	B400	259214-16F0		400						
	248	481	257099B480	259102-16F1		480						
	256	257542-561	257096B560			560	2575660	2575680	2575670	2575650	UY128GAS #9S	
	264	641	B640	259103-16F1	259215-16F0	640						
	356	257542-561	257097B560			257468-560					UY128GAS #10S	
W664-03FC	364	641	B640			640						
	232	257541-321	257098C320	257242-16F1	259214-16F0	257467-320						
	240	401	C400	259102-16F1		400						
	248	481	257099C480			480						
	256	257542-561	257096C560	259103-16F1	259215-16F0	560	2575660	2575680	2575670	2575650	UY128GAS #9S	
W664-03FC	264	641	C640			640						
	356	257542-561	257097C560			257468-560					UY128GAS #10S	
	364	641	C640			640						

W600ゲージパーツ表(2)

W600 GAUGE PARTS LIST(2)

マシン形式 MACHINE TYPE /SPEC	ゲージ GAUGE	針留 NEEDLE HOLDER	針板 NEEDLE PLATE	主送り歯 MAIN FEED DOG	差動送り歯 DIFF FEED DOG	押エ PRESSER FOOT	ルーバー LOOPER	針受け(前)		針受け(後)	スプレッダー SPREADER	針 NEEDLE
								NEEDLE FRONT	NEEDLE REAR			
<b>W664-03GB</b>	240	257541-401	257103B400	257242-16F1	259211-16F0	257471-400	2575660	2575680	2575670	2575650	UY128GAS #9S	
	248	〃 481	〃 B480			〃 480						
	256	257542-561	257104B560			〃 560						
	264	〃 641	〃 B640	257243-16F1	259212-16F0	〃 640						
	356	257542-561	257105B560			257472-560						
	364	〃 641	〃 B640			〃 640						
<b>W664-03GC</b>	240	257541-401	257103C400	257242-16F1	259211-16F0	257471-400	2575660	2575680	2575670	2575650	UY128GAS #9S	
	248	〃 481	〃 C480			〃 480						
	256	257542-561	257104C560			〃 560						
	264	〃 641	〃 C640	257243-16F1	259212-16F0	〃 640						
	356	257542-561	257105C560			257472-560						
	364	〃 641	〃 C640			〃 640						
<b>W664-03KB</b>	248	257541-481	257133B480	257242-16F1	259211-16F0	257471B480	2575660	2575680	2575670	2575650	UY128GAS #11S	
	356	257542-561	257134B560	257243-16F1	259212-16F0	257472B560						
	364	257542-561	259657C560	257243-16F1	259212-16F0	257472-560						
<b>W664-03MC</b>	232	257541-321	257049A320	259104-16F1	259216-16F0	257418-320	2575660	2575680	2575670	2575650	UY128GAS #10S	
	240	〃 401	257050A400	259105-16F1	259217-16F0	257419-400						
	248	〃 481	〃 A480			〃 480						
<b>W664-05BA</b>	256	257542-561	257052A560			257420-560	2575660	2575680	2575670	2575650	UY128GAS #9S	
	264	〃 641	〃 A640	259106-16F1	259218-16F0	〃 640						
	356	257542-561	257053A560			257421-560						
	364	〃 641	〃 A640			〃 640						

W600ゲージパーツ表(3)

W600 GAUGE PARTS LIST(3)

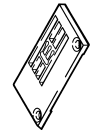

マシン形式 MACHINE TYPE /SPEC	ゲージ GAUGE	針留 NEEDLE HOLDER	針板 NEEDLE PLATE	主送り歯 MAIN FEED DOG	差動送り歯 DIFF.FEED DOG	押エ PRESSER FOOT	ルーバー LOOPER	針受け(前)		針受け(後)	スプレッダー SPREADER	針 NEEDLE
								NEEDLE GUARD FRONT	NEEDLE GUARD REAR			
<b>W664-05BB</b>	232	257541-321	257049B320	259104-16F1	259216-16F0	257418-320	2575660	2575680	2575670	2575650	UY128GAS #9S	
	240	401	257050B400	259105-16F1	259217-16F0	257419-400						
	248	481	480			480						
	256	257542-561	257052B560	259106-16F1	259218-16F0	257420-560						
	264	641	640			640						
	356	561	257053B560			257421-560						
<b>W664-05MC</b>	364	641	640			640	2575660	2575680	2575670	2575650	UY128GAS #10S	
	356	257542-561	259660C560	259106-16F1	259218-16F0	257421-560					UY128GAS #10S	
	240	257541-401	257084B400	257242-16F1	257294-16F0	257460-400					UY128GAS #9S	
	248	481	480			480	2575660	2575680	2575670	2575650	UY128GAS #10S	
	356	257542-561	257095B560	257243-16F1	257295-16F0	257461-560					UY128GAS #9S	
	364	641	640			640	2575660	2575680	2575670	2575650	UY128GAS #10S	
<b>W664-08AC</b>	240	257541-401	257084C400	257242-16F1	257294-16F0	257460-400					UY128GAS #9S	
	248	481	480			480					UY128GAS #9S	
	356	257542-561	257095C560	257243-16F1	257295-16F0	257461-560					UY128GAS #10S	
	364	641	640			640					UY128GAS #10S	
	240	257541-401	257107B400	259109-16F1	259219-16F0	257475-400					UY128GAS #9S	
	248	481	480			480	2575660	2575680	2575670	2575650	UY128GAS #10S	
<b>W664-08BB</b>	356	257542-561	257108B560	259110-16F1	259220-16F0	257476-560					UY128GAS #9S	
	364	641	640			640					UY128GAS #10S	
	240	257541-401	257107C400	259109-16F1	259219-16F0	257475-400					UY128GAS #9S	
	248	481	480			480					UY128GAS #9S	
	356	257542-561	257108C560	259110-16F1	259220-16F0	257476-560					UY128GAS #10S	
	364	641	640			640					UY128GAS #10S	
<b>W664-08DC</b>	240	257541-401	257125C402	257242-16F1	257294-16F0	257460-400					UY128GAS #9S	
	248	481	482			480	2575660	2575680	2575670	2575650	UY128GAS #9S	
	248	257541-481	257126C482	259109-16F1	259219-16F0	257475-480					UY128GAS #9S	
	356	257542-561	257108B560	259110-16F1	259220-16F0	257476-560					UY128GAS #10S	

## W600ゲージパーツ表(4)

## W600 GAUGE PARTS LIST(4)

ミシン形式 MACHINE TYPE /SPEC	ゲージ GAUGE	針留 NEEDLE HOLDER	針板 NEEDLE PLATE	主送り歯 MAIN FEED DOG	差動送り歯 DIFF FEED DOG	押エ PRESSER FOOT	ルーバー LOOPER	針受け(前) NEEDLE GUARD FRONT	針受け(後) NEEDLE GUARD REAR	スプレッダー SPREADER	針 NEEDLE
W664-08MB	248	257541-481	257125B480	257242-16F1	257294-16F0	257460-480	2575660	2575680	2575670	2575650	UY128GAS #9S
	356	257542-561	259663C561	257243-16F1	257295-16F0	257461-560	2575660	2575680	2575670	2575650	UY128GAS #10S
	364	641	641			640	2575660	2575680	2575670	2575650	UY128GAS #10S
W664-08NC	356	257542-561	257195C562	257110-16F1	259220-16F0	257476-560	2575660	2575680	2575670	2575650	UY128GAS #10S
	364	641	641	641	640	640	2575660	2575680	2575670	2575650	UY128GAS #9S
	240	257541-401	257122B400	259109-16F1	259219-16F0	257479-400	2575660	2575680	2575670	2575650	UY128GAS #10S
W664-30AB	248	641	641	641	640	480	2575660	2575680	2575670	2575650	UY128GAS #9S
	356	257542-561	257123C560	259110-16F1	259220-16F0	257480-560					
	364	641	641	641	640	640					
W664-30AC	240	257541-401	257122C400	259109-16F1	259219-16F0	257479-400	2575660	2575680	2575670	2575650	UY128GAS #9S
	248	641	641	641	640	480					
	356	257542-561	257123C560	259110-16F1	259220-16F0	257480-560					
W664-32AB	364	641	641	641	640	640	2575660	2575680	2575670	2575650	UY128GAS #10S
	356	257542-561	257033B560	257246-16F1	257293-16F0	3068410					
	364	641	641	641	640	3070420					
W664-32AC	356	257542-561	257033C560	257246-16F1	257293-16F0	3068410	2575660	2575680	2575670	2575650	UY128GAS #10S
	364	641	641	641	640	3070420					
	356	257542-561	259632B560	259154-16F0	259269-16F0	3068410					
W664-32DC	356	257542-561	259632C560	259154-16F0	259269-16F0	3068410	2575660	2575680	2575670	2575650	UY128GAS #10S
	364	641	641	641	640	3070420					
	356	257542-561	257053B560	259106-16F1	259218A16F0	3070100					
W664-33BB	364	641	641	641	640	3070120	2575660	2575680	2575670	2575650	UY128GAS #10S
	356	257542-561	257053C560	259106-16F1	259218A16F0	3070100					
	364	641	641	641	640	3070120					
W664-33AC	356	257542-561	257053C560	259106-16F1	259218A16F0	3070100	2575660	2575680	2575670	2575650	UY128GAS #10S
	364	641	641	641	640	3070120					

W600ゲージパーツ表(5)

W600 GAUGE PARTS LIST(5)



マシン形式 MACHINE TYPE /SPEC	ゲージ GAUGE	針留 NEEDLE HOLDER	針板 NEEDLE PLATE	主送り歯 MAIN FEED DOG	差動送り歯 DIFF.FEED DOG	押エ PRESSER FOOT	ルーバー LOOPER	針受け(前)		針受け(後)	スプレッダー SPREADER	針 NEEDLE		
								NEEDLE FRONT	REAR					
W664-34AB W664-35AB W664-35BB	240	257541-401	257100B400	259100-16F1	259202-16F0	257485-400						UY128GAS #9S		
	248	481	B480			480					2575660			
	256	257542-561	257101B560			560								
	356		257102B560	259101-16F1	259203-16F0	257486-560								UY128GAS #10S
	364	641	B640			640								
W664-34AC W664-35AC W664-35BC	240	257541-401	257100C400	259100-16F1	259202-16F0	257485-400						UY128GAS #9S		
	248	-481	C480			480					2575660			
	256	257542-561	257101C560			560								
	356		257102C560	259101-16F1	259203-16F0	257486-560								UY128GAS #10S
	364	641	C640			640								
W664-35DC W664-35NB W664-35MC W664-35NC	248	257541-481	257135C482	259100-16F1	259202-16F0	257485-480						UY128GAS #9S		
	248	257541-481	257135B480	259100-16F1	259202-16F0	257485-480					2575660			
	356	257542-561	257196C562			560								
	364	641	C640	259101-16F1	259203-16F0	257486-560								UY128GAS #10S
	356	257542-561	257112B560	259110-16F1	259220-16F0	257480-560								
W664-71AB W664-71AC	356	257542-561	257112C560	259110-16F1	259220-16F0	257480-560						UY128GAS #10S		
	364	641	C640			640					2575660			
	240	257541-401	257111B400	259109-16F1	259219-16F0	257479-400								
	248	481	B480			480								
	356	257542-561	257112B560	259110-16F1	259220-16F0	257480-560								2575660
364	641	B640			640									
240	257541-401	257111C400	259109-16F1	259219-16F0	257479-400									
248	481	C480			480									
W664-81AB W664-81AC	356	257542-561	257112C560	259110-16F1	259220-16F0	257480-560						UY128GAS #10S		
	364	641	C640			640					2575660			
	240	257541-401	257111C400	259109-16F1	259219-16F0	257479-400								
	248	481	C480			480								
	356	257542-561	257112C560	259110-16F1	259220-16F0	257480-560								2575660
364	641	C640			640									



# インデックス

# INDEX

PART. NO.	PAGE	REF. NO.	PART. NO.	PAGE	REF. NO.	PART. NO.	PAGE	REF. NO.	PART. NO.	PAGE	REF. NO.	PART. NO.	PAGE	REF. NO.
000100-9P0	41	1	0045160	71	38	0045540	55	5	0070170	83	10	0070280	47	21
000100A9P0	41	2	0045180	85	26	0045540	57	5	0070170A0	3	19	0070280	51	20
000101-PA0	41	3	0045220	3	27	0045540	59	19	0070170A0	7	12	0070280	53	2
000102-PA0	41	4	0045220	15	30	0045540	65	6	0070170A0	31	23	0070280	63	15
0001030	41	5	0045220	15	33	0045540	73	17	0070170A0	33	31	0070280	65	17
000104APAO	41	9	0045220	19	29	0045540	79	18	0070170A0	45	14	0070280	65	21
000104APAO	41	32	0045220	49	16	0045540	83	32	0070170A0	69	24	0070280	69	37
000104-PA0	41	8	0045220	59	12	0045550	9	17	0070180	5	38	0070280	73	6
000104-PA0	41	31	0045230	85	18	0045550	11	16	0070180	5	41	0070280	75	24
0001050	41	12	0045240	15	14	0045550	11	24	0070180	51	32	0070290	21	18
000106-PA0	41	15	0045270	29	11	0045550	85	2	0070180	53	10	0070290	73	24
0001070	41	16	0045310	17	9	0045560	9	24	0070180	55	13	0070300	75	28
000108-PA0	41	17	0045310	21	21	0045560	11	28	0070180	55	15	0070310	31	6
000109-PA0	41	18	0045310	27	8	0045680	87	34	0070180	55	18	0070310	31	9
0001100	41	21	0045310	35	16	0045810	23	32	0070180	61	3	0070310	51	26
000111-PA0	41	24	0045340	9	9	0045920	11	3	0070180	61	18	0070310	55	24
0001120	41	27	0045340	11	12	0045920	43	20	0070180	61	33	0070310	61	27
000112A0	41	28	0045340	15	18	0045920	47	22	0070180	65	9	0070310	61	41
0001130	41	35	0045340	25	5	0045920	53	3	0070180	83	30	0070310	63	13
0001140	41	36	0045340	87	49	0045920	65	22	007018A0	3	24	0070310	65	15
0001150	41	37	0045350	29	32	0048030	41	20	007018A0	7	20	0070320	65	12
0001160	41	10	0045350	71	25	0048030	41	23	007018A0	21	31	0070340	17	33
0001160	41	33	0045370	7	22	0048030	41	26	007018A0	27	5	0070340	23	29
0001170	41	38	0045370	17	15	0048030	41	30	007018A0	31	30	0070360	9	2
0002260	45	35	0045370	17	41	0048030	45	41	007018A0	33	13	007040	65	2
000247-SAO	45	25	0045370	31	2	0048050	15	6	007018A0	33	20	0070400	83	8
0002500	45	28	0045380	73	16	0048050	23	33	007018A0	33	37	0070410	17	11
000251-SAO	45	30	0045390	3	29	0048050	25	8	007018A0	45	16	0070410	19	45
0002520	45	32	0045390	17	2	0048050	71	39	0070190	19	41	0070410	43	24
0002530	45	27	0045390	17	27	0048050	83	23	0070190	19	43	0070410	47	26
0002530	45	36	0045390	69	8	0048050	85	12	0070190	29	40	0070410	53	7
0002540	45	37	0045390	69	11	0048050	87	55	0070190	51	14	0070410	65	26
0002550	45	39	0045390	71	21	0048200	83	3	0070190	53	16	0070430	43	3
000256-SAO	45	42	0045390	71	23	0048210	33	22	0070190	57	12	0070430	45	2
000257A9S0	45	24	0045390	87	29	0048210	85	39	0070190	61	24	0070430	47	4
0002700	45	26	0045390	87	46	0048210	87	11	007019A0	5	15	0070430	49	3
0003900	73	36	0045400	21	6	0049040	69	50	007019A0	5	21	0070430	51	2
001170-30	23	36	0045400	21	10	0049050	69	52	007019A0	23	31	0070430	53	17
0012060	57	18	0045410	3	26	0049050	73	37	007019A0	27	2	0070430	55	6
0012270	25	20	0045410	9	23	0049050	77	6	007019A0	27	25	0070430	57	6
0014480	45	29	0045410	11	27	0049050	77	20	007019A0	29	2	0070430	59	15
001817-2A0	27	26	0045430	5	23	0049050	79	6	007019A0	29	22	0070430	61	25
001998-20	21	14	0045430	13	22	0049050	79	22	007019A0	29	28	0070430	61	36
0020220	81	21	0045430	13	27	0049050	81	6	007019A0	29	36	0070430	63	2
002022-40	23	26	0045430	13	32	0049050	81	24	007019A0	29	38	0070440	17	35
002133-10	27	12	0045430	15	24	0049060	39	22	007019A0	37	10	0070520	5	13
0021930	29	9	0045430	31	10	0049100	69	48	007019A0	53	19	0070520	5	43
002913-10	81	15	0045430	53	21	0049130	45	31	007019A0	55	21	0070520	81	18
0031440	57	15	0045430	55	22	0050200	39	20	007019A0	57	31	0070560	19	37
0040120	69	56	0045430	57	32	0050530	37	5	007019A0	59	4	0070570	75	3
004065-HU0	41	22	0045430	59	6	0050600	85	14	007019A0	69	26	0070590	21	34
004065-HU0	41	25	0045430	71	35	0050840	23	20	0070200	7	7	0070610	75	14
004065-HU0	41	29	0045430	77	16	0051130	45	21	0070200	7	10	0070620	69	35
004066-HU0	41	6	0045430	77	18	0051180	23	8	0070200	25	22	0070620	73	8
004067-HU0	41	7	0045430	79	16	005138B0	35	3	0070200	43	16	0070620	75	26
004067-HU0	41	14	0045430	79	20	0051610	45	38	0070200	51	12	0070620	85	30
004068-HU0	41	11	0045430	83	17	0051840	23	24	0070200	51	28	0070660	5	30
004068-HU0	41	34	0045460	71	15	0051870	23	22	0070200	57	33	0070660	87	13
0041130	41	19	0045470	9	11	0052420	5	7	0070200	71	40	0070680	77	10
0045000	9	26	0045470	9	13	0053250	13	3	0070200	71	46	0070680	79	10
0045000	69	16	0045470	9	15	005328-HC0	57	23	0070200	73	19	0070680	81	10
0045000	71	3	0045470	9	18	0053760	9	7	007020A0	5	27	0070680	87	21
0045010	11	29	0045470	11	17	0053860	23	17	007020A0	69	20	0070680	87	37
0045010	29	5	0045470	11	20	0054470	27	23	0070210	15	20	0070710	51	17
0045010	75	20	0045470	11	22	005511-HC0	13	20	0070210	15	26	0070740	49	9
0045020	69	17	0045470	11	25	0055460	15	11	0070210	71	42	0070740	59	21
0045020	71	4	0045470	15	2	0056310	83	37	007021A0	5	5	0070740	87	36
0045020	75	21	0045470	17	25	0070080	29	19	007021A0	5	9	0070750	5	17
0045030	77	32	0045470	19	9	0070080	31	31	007021A0	11	9	0070770	29	17
0045030	79	34	0045470	21	24	0070080	83	15	007021A0	13	10	0070770	57	9
0045030	81	36	0045470	25	13	0070090	5	33	007021A0	13	12	0070770	57	25
0045030	87	3	0045470	75	2	0070090	29	15	007021A0	35	22	0070790	5	19
0045040	35	4	0045470	75	8	0070090	31	16	0070220	25	23	0070790	45	11
0045100	87	9	0045470	85	7	0070090	43	12	007022A0	5	25	0070790	83	12
0045100	87	28	0045480	85	3	0070090	47	11	007022A0	21	28	0070790	85	38
0045110	77	11	0045480	85	9	0070090	47	15	007023A0	45	40	0070810	69	18
0045110	79	11	0045500	17	40	0070090	63	10	007024A0	7	14	0070810	71	5
0045110	81	11	0045530	69	2	0070090	63	17	007025A0	23	10	0070820	7	3
0045120	39	5	0045530	71	30	0070100	23	11	007025A0	87	10	0070820	7	5
0045140	11	14	004554	63	6	0070100	29	33	0070260	35	12	0070820	7	18
0045140	19	22	0045540	13	17	0070120	69	41	0070270	39	11	0070820	9	20
0045140	25	2	0045540	13	18	0070120	73	10	0070270	45	9	0070820	31	21
0045140	33	10	0045540	29	48	0070120	75	33	0070270	45	19	0070820	37	8
0045140	35	15	0045540	31	13	0070120	83	20	0070270	45	22	0070820	69	33
0045140	69	4	0045540	43	7	0070130	13	29	0070270	83	5	0070820	73	4
0045140	71	11	0045540	45	6	007015A0	11	10	0070270	83	28	0070820	75	31
0045140	85	27	0045540	47	8	0070170	55	10	0070280	11	2	0070830	87	25
0045140	87	23	0045540	49	7	0070170	55	31	0070280	43	9	0070830	87	42
0045150	73	32	0045540	51	6	0070170	61	6	0070280	43	19	0070830	87	61
0045150	73	35	0045540	53	26	0070170	61	9	0070280	47	18	0070860	13	24



インデックス

INDEX

PART. NO.	PAGE	REF. NO.	PART. NO.	PAGE	REF. NO.	PART. NO.	PAGE	REF. NO.	PART. NO.	PAGE	REF. NO.	PART. NO.	PAGE	REF. NO.
0070930	39	9	2021750	19	2	2068400	33	32	2401430	33	14	250167A0	45	7
0071050	35	13	2021750	19	33	2068510	37	15	2401430	33	36	250167A0	49	8
0071200	51	10	2021750	37	14	2069420	21	16	2401450	33	17	250167A0	51	7
0071280	9	4	2021750	75	12	207065-9P0	37	1	2401480	19	3	250167A0	57	7
0071280	19	16	2021760	17	17	207066-PD0	37	2	2401980	43	6	250167A0	59	1
0071290	15	39	2021760	17	20	207067-PD0	37	3	2401980	45	5	250167A0	61	29
0071300	19	31	2021760	19	21	2070680	37	6	2401980	47	7	250167A0	63	7
0071310	17	29	2021760	25	17	2070730	39	16	2401980	49	6	2501680	7	8
0071320	21	19	2021760	71	12	2070740	39	17	2401980	51	5	250168A0	49	1
0071330	31	28	2021760	71	17	2073580	3	15	2401980	53	25	250168A0	59	2
0071380	87	57	2021760	71	28	2073580	17	18	2401980	55	4	250168B0	53	27
0071390	87	45	2021770	19	12	2073580	19	6	2401980	57	4	250168C0	57	26
0071400	87	33	2021990	33	5	2077860	65	11	2401980	59	18	2501730	7	16
0071410	85	36	2021990	33	18	2079250	17	21	2401980	63	5	2501740	7	17
0071420	17	23	2021990	33	24	2079250	19	19	2401980	65	5	2501750	7	19
0071430	19	27	2021990	33	28	2079250	19	20	2402261	3	9	2501760	7	11
0071430	53	29	2021990	33	33	2079250	19	25	2402261	5	2	250177APD1	51	1
0071430	55	28	2022860	15	10	2079250	25	16	2402270	3	5	250177BPD1	43	2
0071430	57	27	202287A0	35	2	2079250	49	17	2402280	3	3	250177BPD1	47	2
0071430	61	13	2025220	21	11	2079250	59	13	2402280	7	23	250177CPD1	49	2
0071430	61	15	202647A0	31	19	2082860	57	16	2402310	15	16	250177CPD1	59	14
0071430	69	43	2026680	27	9	2084480	27	30	2402320	15	13	250177DPD1	53	22
0071430	75	37	2028750	5	34	2089490	71	32	2402340	17	5	250177EPD1	63	1
0071450	15	36	2028750	67	7	2090840	3	8	240235-920	19	8	250177FPD1	57	1
0071450	51	23	2029010	87	5	2100031	3	7	240235-920	21	23	250177GPD1	55	1
0071450	61	38	2040230	73	31	2100250	5	24	240236-20	17	4	250177HPD1	49	10
0071450	67	12	2040230	77	25	2100250	7	9	240236-20	85	5	250177HPD1	59	20
0071520	11	4	2040230	79	27	2100690	85	19	2402370	17	6	250177MPD1	47	3
0071530	11	5	2040230	81	29	210091-920	9	6	2402390	19	15	2501800	7	4
0071540	67	6	204052A0	19	10	2102000	35	19	2402400	19	24	2501810	5	22
0071560	69	45	204084-20	17	3	210201-PD1	35	21	2402410	19	14	2501810	7	21
0071671	29	45	2041070	29	13	210238-20	19	39	2402420	31	27	2501830	7	24
0071680	83	34	2041610	69	31	2102410	71	36	2402440	33	35	250184-PD1	45	1
0071810	71	24	2041610	73	2	2103070	5	31	2402450	33	34	250186-PD0	45	8
0071960	61	31	204161A0	75	29	2103190	27	27	2402460	37	13	2501890	45	20
0072530	69	22	2045200	81	19	2105850	31	5	2402470	37	11	2501900	45	17
0072530	71	45	2045850	11	30	2105850	31	8	2402490	77	28	2501930	45	13
0072680	11	6	2045850	43	10	2105860	3	30	2402490	79	30	2501960	45	15
007370-HU0	41	39	2045850	45	12	2106790	3	21	2402490	81	32	250200-9P0	7	15
0090160	39	1	2045850	45	33	2106790	3	22	2402500	77	27	250210-910	53	30
0090160	39	13	2045850	47	19	2106790	3	23	2402500	79	29	250224A0	5	14
0090320	39	15	2045850	51	21	2107660	19	34	2402500	81	31	2502250	5	36
009050-9U0	69	53	2045850	63	16	2107660	33	9	2402510	17	39	2502260	5	37
0W00024-10	23	15	2045850	65	18	2107660	37	12	2402510	69	7	250227A0	5	40
0W09070-20	29	24	2045850	83	22	2112470	85	23	2402510	69	10	2502290	29	49
1371080	29	43	2045850	83	26	2113010	21	33	2402510	71	20	250230-FA0	23	37
1371420	77	21	204754A0	29	8	2113880	29	44	2402510	71	27	250231A910	5	35
1371420	79	23	2050610	29	7	2120390	25	19	2402520	23	3	250234-TD0	5	20
1371420	81	25	2050610	77	29	2121860	13	15	2402530	23	4	2502520	57	8
1374410	87	51	2050610	79	31	2300300	69	12	2402570	87	6	2502540	55	14
1374410	87	56	2050610	81	33	2300300	71	6	240257A0	87	7	2502550	5	26
1379060	57	21	2050881	3	11	2300300	75	16	2402580	87	19	2502560	5	29
1670660	57	17	2050970	43	23	2310110	15	32	2402590	87	31	2502570	5	32
1670660	83	19	2050970	47	25	2325080	21	13	2402610	31	12	2502630	43	11
1670790	31	29	2050970	53	6	2330200	25	18	2402630	5	10	2502630	47	16
179040-050	13	13	2050970	65	25	2345210	29	31	2402660	83	14	250264-910	53	12
179107-050	5	3	2054670	39	12	2345610	29	23	2402670	83	16	250264-910	61	20
179160-050	75	5	205468-UA0	69	54	2350400	65	19	2404740	23	12	250280APD0	57	28
179320-050	19	5	205469-UA0	69	55	2400010	3	13	2404740	29	20	250280-PD0	7	13
1920240	23	14	2057640	39	7	2400060	33	23	2405680	33	15	2502810	61	35
1921200	27	3	2057650	39	8	2400080	69	5	2405880	83	38	250321-910	51	30
2001360	33	4	206050C0	9	27	2400080	71	9	2500130	43	4	250321-910	53	8
200140A0	33	39	2060530	13	5	2400080	75	9	2500130	45	3	250321-910	55	7
2001520	33	6	2060610	13	2	240011-20	87	53	2500130	47	5	250321-910	61	1
2001520	33	27	2060630	13	8	2400170	17	31	2500130	49	4	250321-910	65	7
2007280	39	18	2061150	27	4	2400260	47	9	2500130	51	3	2503880	3	28
2009830	17	38	2061390	23	7	2400390	19	36	2500130	53	23	2504340	67	8
2010370	27	29	2061480	23	25	2400390	75	4	2500130	55	2	2504350	67	9
2010680	27	33	2061490	23	21	2400420	45	23	2500130	57	2	2505060	11	15
201074A0	15	9	2061560	23	19	2400450	3	10	2500130	59	16	2505140	9	19
2010860	27	32	2061570	23	16	2400520	3	4	2500130	63	3	250517A0	43	21
2011910	43	5	206172-20	15	3	2400550	17	10	2500130	65	3	250517A0	47	23
2011910	45	4	2061800	25	10	2400620	15	7	2500190	5	4	250517A0	53	4
2011910	47	6	2061800	85	21	2400620	25	7	2500200	3	17	250517A0	65	23
2011910	49	5	2062020	27	24	2400620	85	11	2501170	3	2	2505240	11	13
2011910	51	4	2062030	27	21	2400630	21	35	2501480	3	12	250526B910	11	1
2011910	53	24	2062330	35	18	2400970	19	4	250150-PD0	5	1	250526C910	43	18
2011910	55	3	2063290	39	10	240098-20	13	6	250151BTD0	5	6	250526C910	47	20
2011910	57	3	2063360	39	3	2401010	13	7	2501530	5	8	250526C910	53	1
2011910	59	17	2063370	39	6	2401020	87	32	2501540	5	11	250526C910	65	20
2011910	63	4	2063380	39	2	2401100	3	6	2501550	5	12	250528-910	11	23
2011910	65	4	2063380	39	14	240114A0	87	41	250156-TB0	5	16	250529-910	11	19
2012520	15	15	2064310	35	20	2401230	31	20	2501570	3	18	250529A910	9	12
2012520	29	12	2064390	45	10	2401240	21	27	250158-910	3	16	250530-910	9	16
2012520	57	22	2064600	45	18	2401260	9	25	2501590	5	18	250545-910	9	14
2016290	17	37	2065240	13	14	2401270	3	20	2501600	7	1	250547A0	11	21
2016290	21	5	2065900	3	1	2401290	21	9	2501610	7	2	2505510	9	1
2016350	85	13	2067480	19	7	2401310	15	40	250162-PD0	7	6	2505520	11	18
2020450	39	19	2067480	19	13	2401350	33	3	2501670	43	1	250554-920	9	3
2021740	75	11	2067810	37	4	2401360	33	8	2501670	47	1	250555-910	9	5

# インデックス

# INDEX

PART NO.	PAGE	REF. NO.	PART NO.	PAGE	REF. NO.	PART NO.	PAGE	REF. NO.	PART NO.	PAGE	REF. NO.	PART NO.	PAGE	REF. NO.
2505560	9	21	252675A0	49	12	255094-910	33	25	256510-9P0	87	1	2580350	83	27
250557-910	9	10	252675A0	59	8	255097-910	33	21	2565120	87	2	2580360	83	11
250560A0	11	7	253000-910	23	1	2550990	33	19	256513-920	87	48	2580370	83	7
2505610	9	22	2530031	23	2	255100-910	33	29	2565140	87	50	2580380	83	6
250566-TD0	11	26	253005-910	23	9	2551020	33	30	2565150	87	52	258039-910	83	9
251010A0	43	22	253008-910	23	13	255103-910	37	7	2565160	87	54	2580410	83	13
251010A0	47	24	2530100	23	18	2551070	37	9	2565170	87	8	2580420	83	24
251010A0	53	5	2530130	23	27	2551080	3	14	2565180	87	4	2580430	83	21
251010A0	65	24	2530140	23	28	2551230	33	26	2565190	87	12	2580440	83	18
251014-910	13	1	2530150	23	30	2551440	35	5	2565200	87	15	258045-910	83	1
2510160	13	4	2530180	23	6	255519-9P0	69	15	2565210	87	16	2580460	57	30
2510171	13	9	2530260	23	5	255519A9P0	71	1	2565220	85	34	2580460	59	5
2510180	13	11	2530270	23	23	2555210	49	11	2565230	85	35	258046A0	53	20
251510-920	13	21	2530280	23	34	2555210	59	7	256524-910	87	17	258046A0	55	20
2515110	13	23	253500-920	11	8	255522-920	49	15	2565270	87	18	2580470	53	18
2515120	13	25	253501A920	11	11	255522-920	59	11	256528-920	87	27	2580470	55	19
251513-920	13	28	2535030	29	10	255523-C0	49	13	256529A0	87	20	2580470	57	29
2515140	13	30	253504-920	29	4	255523-C0	59	9	256530A0	87	22	2580470	59	3
2520350	15	4	253505A1	29	1	2555250	69	1	2565310	87	24	258049-910	53	28
252036-920	15	1	2535060	29	34	2555260	69	3	2565320	87	30	258050-910	55	8
252037-910	15	5	2535070	29	14	2555270	69	6	2565330	87	26	258050-910	61	5
2520390	15	8	253508A0	29	16	2555280	69	9	2565350	87	43	2580680	57	24
252040-920	15	19	253509A0	29	18	2555290	69	29	256536-9P0	85	24	258069B910	57	19
2520410	15	21	2535110	29	47	255529A0	73	12	2565380	87	59	2580710	57	20
2520410	15	27	2535140	29	35	2555310	69	19	2565390	87	60	2580720	57	10
2520420	15	22	2535150	29	37	2555310	71	2	2565400	85	31	2580730	55	29
2520430	15	23	2535160	29	21	255533-910	69	32	2565410	85	32	2580740	55	25
2520440	15	12	2535170	29	25	255533-910	73	3	2565430	87	58	2580930	57	34
252045-920	15	25	253533D0	31	7	255534-910	69	30	2565440	85	33	2590000	39	4
252046-920	15	17	253534A0	31	4	255534-910	73	1	2565450	85	25	259003-TB0	39	21
2520470	15	28	2535440	29	27	255536-910	69	23	2565460	85	28	2590040	77	5
2520480	15	34	2535450	29	30	2555420	69	25	2565470	85	29	2590040	79	5
252049-910	15	31	2535470	29	42	255545-910	69	36	2565480	87	35	2590040	81	5
2520520	15	29	253548B0	29	39	255545-910	73	5	256550-910	87	44	2590050	77	8
252053-920	15	35	2535860	31	24	2555460	69	14	2565580	87	47	2590050	79	8
252053A920	51	22	2535880	31	26	2555460	71	8	2575650	25	24	259005A0	81	8
252053A920	61	37	253588A0	31	25	2555460	75	18	2575690	47	10	2590060	77	9
252053A920	67	11	2535920	31	3	2555480	69	13	2575690	63	8	2590060	79	9
2520550	15	37	2535930	29	26	2555480	71	7	2575700	47	12	2590060	81	9
2520550	51	24	2536000	31	11	2555480	75	17	2575700	63	9	2590070	77	19
2520550	61	39	2536010	31	18	255549-9P0	75	19	2575710	51	8	2590070	79	19
2520550	67	13	2536050	31	22	2555520	75	1	2575720	51	9	2590070	79	21
252056-920	9	8	253606A0	31	14	2555530	75	6	2575730	69	34	2590070	81	23
2520690	21	32	253607-910	31	17	2555540	75	7	257573A0	69	38	2590100	77	30
252557A0	75	10	2536680	29	50	2555550	75	15	257573A0	73	7	2590100	79	32
252607-920	17	1	2536770	67	2	2555570	75	22	2575740	75	25	2590100	81	34
2526080	17	7	2536780	67	1	255558-910	75	30	2575750	47	13	2590110	77	31
252609-920	17	8	2536800	31	15	2555600	75	27	2575760	47	14	2590110	79	33
2526100	19	1	2536820	67	5	2555620	75	36	2575771	51	15	2590110	81	35
2526120	17	12	2536830	67	4	255564-910	75	23	257577A0	61	30	2590120	77	13
2526130	17	16	2536840	67	3	255567-910	75	34	2575780	51	18	2590120	79	13
2526140	17	13	253693-910	31	1	2555710	69	40	2575780	61	32	2590130	77	14
2526150	17	14	254000-910	27	10	255571A0	73	9	2575790	51	16	2590130	79	14
2526160	17	19	254003B910	27	7	255574-910	71	10	2577430	61	26	2590140	77	17
2526170	17	22	2540080	27	1	2555770	71	16	257743A0	61	28	2590150	83	25
252618-910	17	24	2540190	27	15	2555780	71	18	257743A0	61	40	259015A0	77	12
2526200	17	28	2540200	27	20	2555790	71	14	2577610	51	27	259015A0	77	24
2526210	17	30	2540210	27	16	2555810	71	13	2577610	55	23	259015A0	79	12
2526220	17	26	2540220	27	11	255582-920	71	22	2577610	63	11	259015A0	79	26
2526230	17	32	254023B9T0	27	13	2555830	71	26	2577610	65	13	259015A0	81	12
252624-TB0	17	34	254023C9T0	27	14	2555860	69	39	257761A0	51	25	259015A0	81	28
2526250	17	36	254023D9T0	27	34	255586A0	73	11	257761A0	63	12	2590170	81	16
2526260	17	42	254023E9T0	27	35	2555870	69	42	257761A0	65	14	259018-910	77	26
2526280	19	28	254501A920	25	1	2555880	69	46	2580100	43	13	259018-910	79	35
2526290	19	30	254503-920	25	4	2555890	69	47	2580110	43	14	259018-910	81	37
252630-C0	19	44	2545040	25	6	2555900	69	44	258013-910	43	15	259018A911	79	28
2526310	19	18	2545040	85	10	2556030	71	19	258013-910	51	11	259019-910	81	30
2526320	19	38	254506B0	25	12	2556040	71	29	2580140	51	31	2590200	77	15
252633-910	19	11	2545070	25	14	2556150	75	32	2580140	53	9	2590200	79	15
2526360	19	32	2545110	25	3	2556170	71	31	2580140	55	16	259021-910	77	2
2526370	19	35	254516-920	25	21	2556180	71	33	2580140	61	2	259021A910	79	2
2526390	19	26	2545180	25	15	2556190	71	34	2580140	65	8	259022-910	77	3
2526410	21	1	2545190	25	9	2556200	71	37	258015A910	61	17	259022A910	79	3
2526420	21	2	2550030	33	7	2556250	73	13	258015B910	55	11	259023-910	77	4
2526430	21	3	2550050	33	12	255630-910	73	18	258017B910	61	8	259023-910	79	4
2526440	21	7	2550190	35	14	2556380	69	21	258020A910	55	27	259023-910	81	4
2526450	21	12	2550210	33	11	2556380	71	44	258020A910	61	12	259024-910	81	2
2526460	21	8	2550240	35	7	2556400	73	14	258020B910	61	14	259025-910	81	3
252648-910	21	15	2550250	35	8	2556430	73	15	2580230	55	26	259026-910	77	1
252651-920	21	17	2550260	35	9	2556440	71	47	2580230	61	11	259026A910	79	1
252652-920	21	20	2550270	35	10	2556460	71	41	2580240	53	14	259027-910	81	1
252653-910	21	22	2550280	35	11	2560120	87	38	2580240	61	22	2590280	79	17
2526560	21	26	255035-910	33	1	256500-920	85	1	2580260	53	15	263542A9T0	27	17
2526570	21	25	2550370	33	2	2565010	85	4	2580260	61	23	263542B9T0	27	18
2526580	21	29	2550380	33	16	2565020	85	6	2580270	53	13	263542C9T0	27	19
252659-910	19	23	2550390	33	38	2565030	85	8	2580270	61	21	263543-TA0	27	31
2526600	17	43	2550410	35	1	256504-9P0	85	15	2580310	83	2	263544-TA0	27	28
2526650	21	4	2550770	75	13	2565070	85	16	2580320	83	4	2750340	29	46
252														

# インデックス

# INDEX

PART. NO.	PAGE	REF. NO.	PART. NO.	PAGE	REF. NO.	PART. NO.	PAGE	REF. NO.	PART. NO.	PAGE	REF. NO.	PART. NO.	PAGE	REF. NO.
3003870	73	29	9A30710	3	33									
3028320	73	25	9A30720	3	34									
3030670	29	6	9A31260	5	44									
3030670	45	34												
303067A0	41	13												
3030970	73	27												
3033350	39	23												
3033350	73	34												
3034480	3	25												
3034480	5	28												
3034480	5	39												
3034480	5	42												
3034480	21	30												
3034480	27	6												
3034480	29	3												
3034480	29	29												
3034480	29	41												
3034480	43	17												
3034480	51	13												
3034480	51	29												
3034480	51	33												
3034480	53	11												
3034480	55	9												
3034480	55	12												
3034480	55	17												
3034480	55	30												
3034480	57	11												
3034480	61	4												
3034480	61	7												
3034480	61	10												
3034480	61	16												
3034480	61	19												
3034480	61	34												
3034480	65	10												
3034480	69	57												
3034480	71	43												
3034480	73	20												
3060110	49	14												
3060110	59	10												
3061680	73	22												
3062430	87	40												
3063010	27	22												
306473-UA0	69	49												
306474A0	69	51												
3065000	87	39												
3065870	73	26												
3066710	25	11												
3066710	85	22												
3066760	73	30												
3067890	85	37												
3067890	87	14												
3068230	81	13												
3068290	77	22												
3068290	79	24												
3068290	81	26												
306830B0	77	23												
306830B0	79	25												
306830B0	81	27												
3068380	81	14												
3068430	81	22												
3069400	57	14												
3069410	57	13												
3070180	83	36												
3070190	83	35												
3070230	83	33												
3070250	81	17												
3070260	81	20												
350247-PD1	65	1												
3506220	77	7												
3506220	79	7												
3506220	81	7												
5110090	73	23												
5260030	73	40												
6001750	73	39												
6010470	73	21												
601110A0	69	27												
6011150	69	28												
6011150	75	38												
6011200	73	38												
6080050	75	35												
6A005600000	43	8												
6A005600000	47	17												
6A005600000	51	19												
6A005600000	63	14												
6A005600000	65	16												
9A21490	41	40												
9A30020	35	23												
9A30670	3	31												
9A30690	3	32												
9A30690	3	35												

# ペガサスミシン製造株式会社

本社 〒553-0002 大阪市福島区鷺洲 5-7-2 TEL (06)6458-4739  
FAX (06)6454-8785

PEGASUS SEWING MACHINE MFG. CO., LTD.  
5-7-2, Sagisu, Fukushima-ku, Osaka 553-0002, Japan. Phone :(06)6458-4739  
Telefax:(06)6454-8785

Cat. No. 9586△ March 2002

©1999 PEGASUS SEWING MACHINE MFG. CO., LTD.

このパーツカタログに記載されている内容は、改良のため予告なく変更することがあります。

The description in this PARTS CATALOG is subject to change without prior notice for improvement.