

PFAFF

422

422-720/04

Teileliste

Parts list

Liste de pièces

Lista de piezas

1422

1422-720/04

Avant-propos Notas preliminares

Die Inhaltsübersicht auf Seite 3 gibt einen Überblick über die Aufgliederung der Liste. Alle Teile sind so abgebildet, wie sie in der Maschine funktionsmäßig zusammengehören. Die gestrichelten Abbildungen zeigen, wo die daneben abgebildeten Teile hingehören. Einrahmungen auf den Bildseiten zeigen, aus welchen Einzelteilen sich die Gruppenteile zusammensetzen. Nähwerkzeuge und Apparate sind der Unterklassen-Ausstattung zu entnehmen. Die auf den Bildseiten verwendeten Schlüsselzeichen (; 2 ; 3 usw.) sind in Register "A - 99" erläutert.

Konstruktionsänderungen vorbehalten.



Achtung!

Wir machen ausdrücklich darauf aufmerksam, daß Ersatz- und Zubehörteile, die nicht von uns geliefert werden, auch nicht von uns geprüft und freigegeben sind. Der Einbau und / oder die Verwendung solcher Produkte kann daher u. Umständen konstruktiv vorgegebene Eigenschaften Ihrer Maschine negativ verändern. Für Schäden, die durch die Verwendung von Nicht-Originalteilen entstehen, übernehmen wir keine Haftung!

For the various sections of this catalogue, please refer to the "Contents" on page 3. The parts are illustrated as they belong together in the machine. The dashed illustrations show where the adjacent parts belong. The framed-in sections on the illustration pages show the individual parts comprising a group. For gauge parts and attachments please refer to the subclass listing. The keys used on the illustration pages (; 2 ; 3 etc.) are listed and explained in section "A - 99".

Subject to alterations in design.



Caution!

We warn you expressively that spare parts and accessories that are not supplied by us are not tested and released by us. Fitting or using these products may therefore have negative influences on features that depend on the machine design. We are not liable for any damage caused by the use of non-Pfaff parts.

La table des matières, page 3, donne un aperçu de la subdivision de la liste. Les pièces figurent sur l'illustration comme elles vont ensemble. Les figures en tirets montrent le lieu de montage des pièces figurant à côté. Les parties encadrées sur les pages à illustrations représentent les pièces individuelles formant groupe. Pour les organes de couture et les appareils, veuillez vous référer à la fiche équipement de sous-classes.

Les symboles (; 2 ; 3 etc.) utilisés sur les pages illustrées sont regroupés et expliqués au registre "A - 99".

Sous réserve de modifications.



Attention!

Nous attirons expressément votre attention sur le fait que les pièces de rechange et accessoires qui n'ont pas été livrés par nous n'ont pas non plus été contrôlés et agréés par nous. C'est pourquoi le montage et/ou l'utilisation de telles pièces peut éventuellement entraîner l'altération des caractéristiques de construction de votre machine. Par conséquent, nous n'assumons aucune responsabilité pour les dommages causés par l'emploi de pièces qui ne sont pas d'origine!

En la página 3, bajo el título "contenido", puede verse un resumen de la división de la "lista de piezas". Las piezas están ilustradas conforme se hallan montadas en la máquina. Las figuras a base de líneas entrecortadas muestran dónde y cómo van montadas las piezas ilustradas al lado. Los recuadros en las páginas ilustradas indican las piezas individuales de que se componen los grupos. Para los órganos de costura y aparatos, véase la "Composición de las subclases". Los símbolos clave (; 2 ; 3 etc.) utilizados en las páginas ilustradas se hallan recopilados y explicados en el registro "A - 99".

Salvo modificaciones técnicas.



¡Atención!

Se hace observar que en el caso de piezas de recambio y accesorios que no hayan sido suministrados por nosotros, quiere decir que no han sido sometidas por nuestra parte a un control y que no se les ha dado el visto bueno. Por esta razón, el montaje y/o empleo de tales productos puede repercutir negativamente en las características constructivas previstas en su máquina. ¡Para los daños que eventualmente pudiesen presentarse al utilizar piezas no originales, no asumimos ninguna garantía!

Explicaciones de los códigos

Kopf-, Arm-, Grundplatten- und Gehäuseteile
 Needle head parts, arm-, base plate-, and housing parts
 Pièce de tête, bras, plaque fondamentale et carcasse
 Piezas de la cabeza, del brazo, de la placa base y de la carcasa

Nadelstangen-Schalteinrichtung
 Disengageable right and left needles -720/04
 Commande de barres à aiguilles
 Barra de aduja desconectable a izquierda y derecha

Walzentransport-Einrichtung
 Puller feed -748/26
 Puller
 Puller

Fadenabschneid-Einrichtung
 Thread trimmer -900/56
 Coupe-fil -900/61
 Cortahilos

Fadenspannungs-Steuerung
 Thread tension control -906/03
 Commande de la tension du fil -906/09
 TlControl de la tensión del hilo superior

Fadenabstreif-Einrichtung
 Thread wiper -909/02
 Racleur de fil
 Retirahilos

Presserfuß-Automatik -910/04
 Automatic presser foot lift -910/15
 Relève-pied automatique -910/24
 Alzaprensatelas

Verriegelungs-Einrichtung
 Backtacking mechanism -911/35
 Dispositif à points d'arrêt
 Rematador

Schalteinrichtung
 Switching system -918/26
 Dispositif de commande
 Mecanismo de mando

Wartungseinheit
 Air filter / lubricator -925/02
 Conditionneur d'air comprimé
 Grupo acondicionador del aire comprimido

Spulenfadenvorratswächter
 Bobbin thread supply monitor -926/06
 Contrôleur de canette
 Detector del hilo de la canilla

Zubehörteile, Einstellehren
 Accessory parts, Adjustment gauges
 Accessoires, calibres
 Accesorios, Calibres de ajuste

Keilriemenscheiben- und Schmiermitteltabelle
 Table of pulleys and lubricants
 Tableau des poulie pour courroie trapézoïdales et des lubrifiants
 Tabla de poleas para correas trapezoidales y lubricantes

Index (Teilenummern / Seitenzahlen)
 Index (part numbers / page numbers)
 Index (numéros de pièces, de pages)
 Index (números de pieza / números de página)

Nähwerkzeuge und Apparate
 Gauge parts and attachments
 Outils de couture et guides

- Unterklassenabhängig, Teilenummer siehe Nähwerkzeuge und Apparate.
Subclass-dependent, for part number see gauge parts and attachments.
Fonction de la sous-classe; pour le numéro de la pièce, voir "organes de couture et guides".
Dependientes de la subclase, para el número de pieza véase "órganos de costura y aparatos".
- A** Ausführung A
Model A
Version A
Tipo A
- B** Ausführung B
Model B
Version B
Tipo B
- C** Ausführung C
Model C
Version C
Tipo C
- 2** Markierung (Punkte, Striche oder Zahl) bei Bestellung angeben.
Marking (dots, strokes or numbers) to be stated on order.
Préciser les repères (points, traits ou chiffres) à la commande.
Señales (puntos, rayas o cifras), indíquese en los pedidos.
- 3** Geklebt
Part cemented
Pièce collée
Pieza pegada
- 3/1** Gesichert mit Loctite.
Secured with Loctite.
Bloqué par Loctite.
Asegurado con Loctite.
- 4** Ausführungsart bei Bestellung angeben.
Model to be stated on order.
Préciser le modèle à la commande.
Indíquese el tipo en los pedidos.
- 5** Nähmuster bzw. Material einsenden.
Submit sewing sample or material.
Joindre échantillons de couture ou matières.
Enviense muestras de costura.
- 6** Nadeldicke und Spitzenform bei Bestellung angeben.
Needle size and style of point to be stated on order.
Préciser la grosseur de l'aiguille et la forme de la pointe à la commande.
Grosor de aguja y forma de la punta, indíquese en los pedidos.
- 10** Nadelabstand
Needle gauge
Ecartement des aiguilles
Distancia entre agujas

- 10/1 Je nach Nadelabstand ändert sich die Form (z. B. beim Stoffschieber die Anzahl der Zahnreihen)
Certain design features change according to the needle gauge (e.g. the number of tooth rows on the feed dog).
Forme varie en fonction de l'écartement des aiguilles (le nombre de rangées de dents, p.ex., dans le cas de la griffe).
La forma varía según la distancia entre agujas para el transportador inferior, el número de hileras de dientes).
- 10/2 Nadelabstand bei Bestellung angeben
Needle gauge to be stated on order
Préciser l'écartement des aiguilles à la commande, s-v-p.
Indíquese en los pedidos la distancia entre agujas
- 10/5 Für Nadelabstand von 2,4 mm.
For needle gauge from 2.4 mm.
Pour écartement des aiguilles entre 2,4 mm.
Para distancia entre agujas 2,4 mm.
- 12 Absteppbreite
Stiching margin
Relarge de couture
Margen de costura
- 12/2 Absteppbreite bei Bestellung angeben
Stitching margin to be stated on order
Indiquer le relarge de couture à la commande
Indíquese el margen de costura en los pedidos
- 23/1 Für 7 mm Stoffdurchgang.
For a fabric clearance of 7 mm.
Pour un passage sous le pied de 7 mm.
Para 7 mm de pasaje para el material.
- 23/2 Für 9 mm Stoffdurchgang
For a fabric clearance of 9 mm
Pour un passage sous le pied de 9 mm
Para 9 mm de pasaje para el material
- 27/2 Eingeklammerte Zahl = Dicke in mm
Number in parentheses = thickness in mm
Chiffre entre parenthèses = épaisseur en mm
Cifra entre paréntesis = espesor en mm
- 27/5 Eingeklammerte Zahl = Länge in mm
Number in parentheses = length in mm
Chiffre entre parenthèses = longueur en mm
Cifra entre paréntesis = largura en mm

27/12

Eingeklammerte Zahl = Länge in mm.
Number in brackets = length in mm.
Chiffre entre parenthèses = épaisseur en mm.
Cifra entre paréntesis = largura en mm.

28

Sonderausführung
Special version
Version spéciale
Tipo especial

32

Beim Einbau dieses Teiles wird für die Paßgenauigkeit zum Anschlußteil keine Garantie übernommen;
zweckmäßig vollständiges Aggregat bestellen.
No guarantee is assumed that this part will fit the mating part; it is best to order a complete assembly.
Aucune garantie ne pourra être assurée quant à la précision d'ajustage de cette pièce avec la pièce
correspondante; il est indiqué de commander un mécanisme complet.
Al montar esta pieza no se asume garantía alguna en cuanto a la tolerancia y precisión de ajuste
respecto a la pieza correspondiente; por esta razón, se recomienda pedir el grupo completo.

32/1

Beim Einbau dieses Teiles ist Nacharbeit erforderlich.
When fitting this part re-work is required.
Retouches nécessaires au montage.
Al montar esta pieza hay que retocarla antes.

35/1

Bei Montage vernieten.
To be riveted after assembly.
River après montage.
Remáchese después del montaje.

38/7

Kunststoffbeschichtet
Plastic-coated
A enduction plastique
Revestido de plástico

38/8

Gezahnt
Toothed
Dentée
Dentado

38/9

Gerändelt
Knurled
Molleté
Moleteado

40/1

Füllen mit 280-1-120 144; Bestellnummer siehe Seite 72.
Top up with 280-1-120 144; for part number see page 72.
Remplir de 280-1-120 144; n° de commande, voir page 72.
Rellene con 280-1-120 144; para el número de pedido véase la página 72.

40/2

Tränken mit 280-1-120 144; Bestellnummer siehe Seite 72.
Soak with 280-1-120 144; for part number see page 72.
Imbiber d'huile 280-1-120 144; n° de commande, voir page 72.
Empape con aceite 280-1-120 144; para el número de pedido véase la página 72.

40/3

Fetten mit 280-1-120 247; Bestellnummer siehe Seite 72.
Grease with 280-1-120 247; for part number see page 72.
Graisser avec de la graisse 280-1-120 247; n° de commande, voir page 72.
Engrase con grasa 280-1-120 247; para el número de pedido véase la página 72.

40/4

Fetten mit 280-1-120 243; Bestellnummer siehe Seite 72.
Grease with 280-1-120 243; for part number see page 72.
Graisser avec de la graisse 280-1-120 243; n° de commande, voir page 72.
Engrase con grasa 280-1-120 243 para el número de pedido véase la página 72.

40/5

Ölen mit 280-1-120 144; Bestellnummer siehe Seite 72.
Oil with 280-1-120 144; for part number see page 72.
Huiler par 280-1-120 144; n° de commande, voir page 72.
Lubrifique con 280-1-120 144; para el número de pedido véase la página 72.

40/13

Fetten mit 280-1-120 205; Bestellnummer siehe Seite 72.
Grease with 280-1-120 205; for part number see page 72.
Graisser avec de la graisse 280-1-120 205; n° de commande, voir page 72.
Engrase con grasa 280-1-120 205; para el número de pedido véase la página 72.

40/20

Füllen mit 280-1-120 122; Bestellnummer siehe Seite 72.
Top up with 280-1-120 122; for part number see page 72.
Remplir de 280-1-120 122; n° de commande, voir page 72.
Rellene con 280-1-120 122; para el número de pedido véase la página 72.

41/2

Nadeldiagonalabstand bei Bestellung angeben.
Please state diagonal needle distance on order.
Prière d'indiquer l'espacement diagonal des aiguilles à la commande.
Indíquese en los pedidos la distancia diagonal entre agujas.

- 80/3 Für Schlauch mit 3 mm Innendurchmesser
For tube with 3 mm inside diameter
Pour flexible d'un diamètre intérieur de 3 mm
Para tubo flexible de 3 mm de diámetro interior
- 81/3 Verwendung je nach Bedarf.
To be used as required.
Utilisation en fonction des besoins.
Utilización, según sea necesario.
- 81/4 Verwendung nur nach Bedarf.
To be used only if required.
Utilisation uniquement suivant besoin.
Utilización, sólo cuando se necesite.
- 90/38 Mit -900/.. ohne Anbau-Unterklassen.
With -900/.. without mechanical subclasses.
Avec -900/.. sans sous-classes mécaniques.
Con -900/.. sin subclases mecánicas.
- 90/39 Mit -900/.. mit Anbau-Unterklassen.
With -900/.. with mechanical subclasses.
Avec -900/.. avec sous-classes mécaniques.
Con -900/.. con subclases mecánicas.
- 90/66 Für Walzen mit 10, 15 und 30 mm breite.
For roll widths 10 mm, 15 mm and 30 mm.
Pour pullers de 10, 15 ou 30 mm de large.
Para puller con 10, 15 y 30 mm de anchura.
- 90/67 Für Walzen mit 45 mm breite.
For roll width 45 mm.
Pour pullers de 45 mm de large.
Para puller con 45 mm de anchura.
- 90/68 Für Walzen mit 10 und 15 mm breite.
For roll width 10 mm and 15 mm.
Pour pullers de 10 ou 15 mm de large.
Para puller con 10 y 15 mm de anchura.

90/69

Für Walzen mit 30 mm breite.
For roll width 30 mm.
Pour pullers de 30 mm de large.
Para puller con 30 mm de anchura.

90/70

Für Maschinen ohne -720/..
For machines without -720/..
Pour les machines sans -720/..
Para máquina sin -720/..

96

Länge angeben.
State length.
Préciser longueur.
Indíquese la largura.

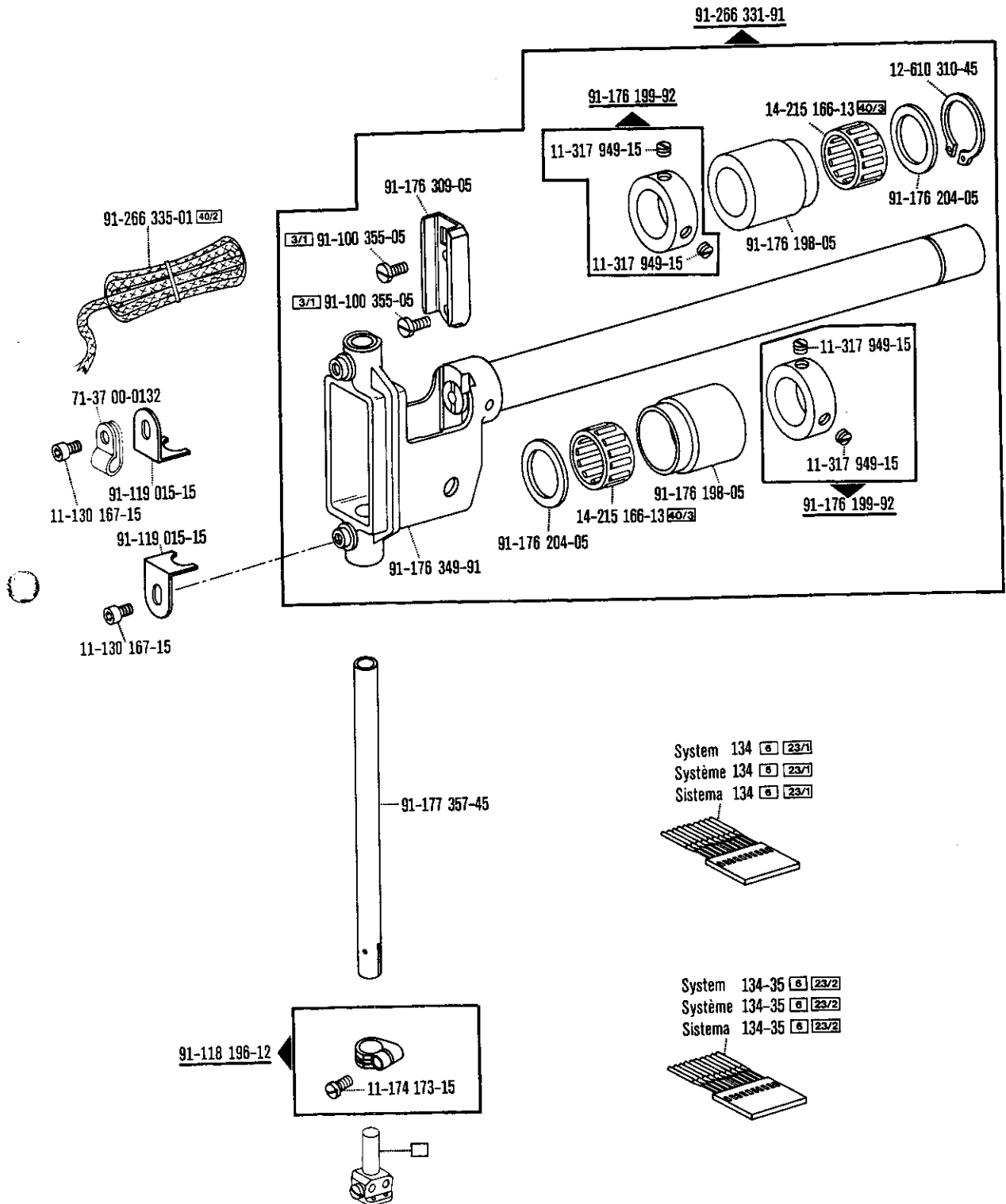

□ siehe Erläuterungen Register A-99
 see explanations in section A-99
 voir légende registre A-99
 ver explicaciones del registro A-99

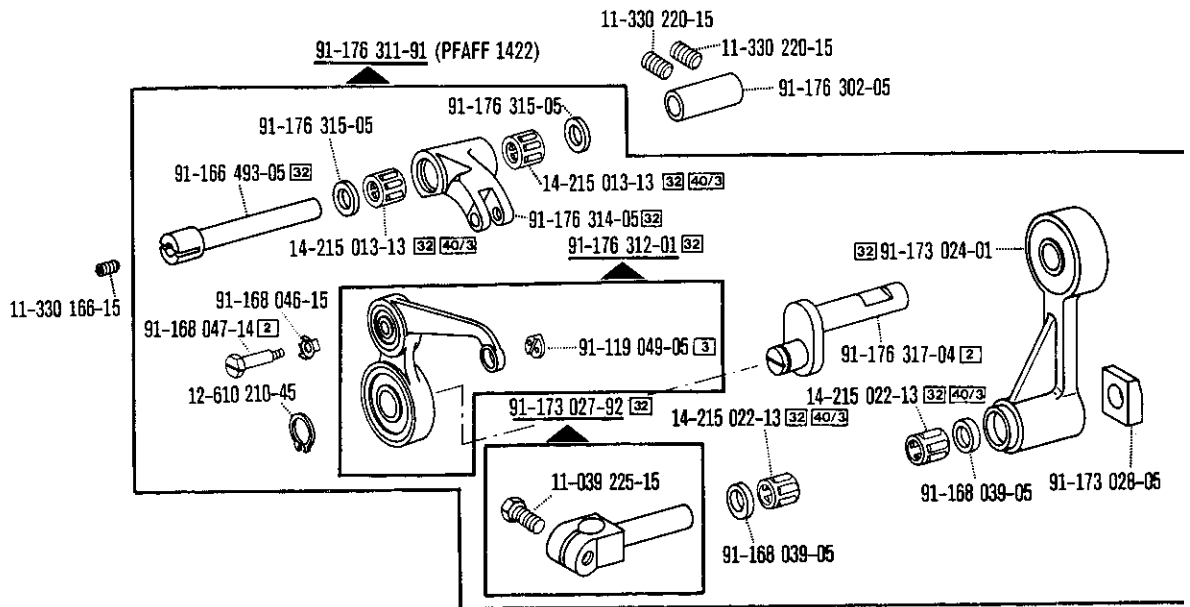
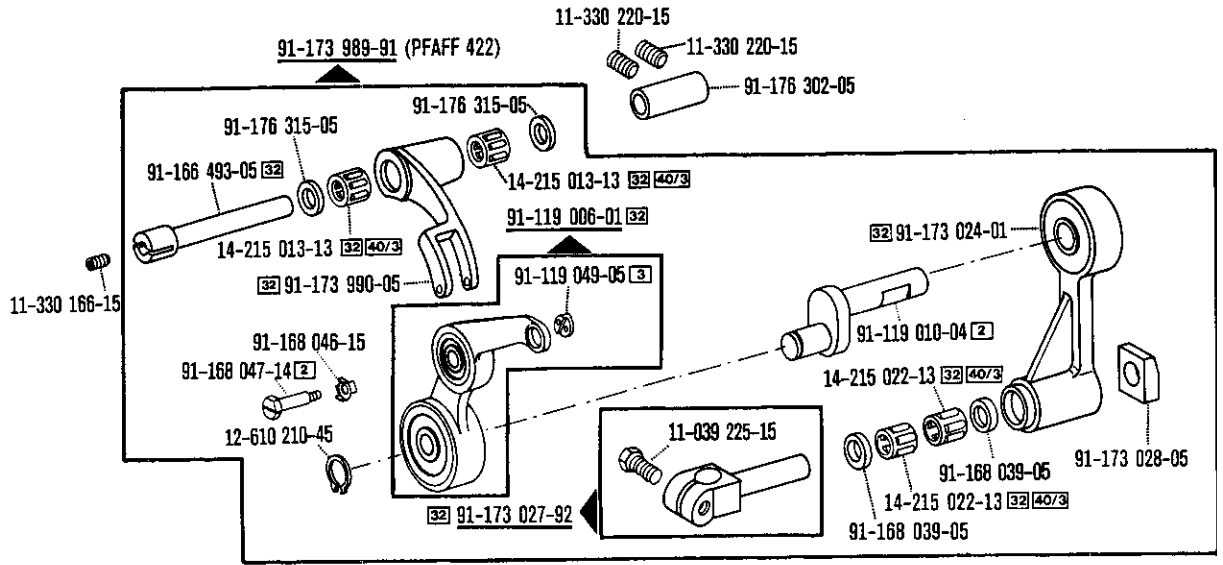

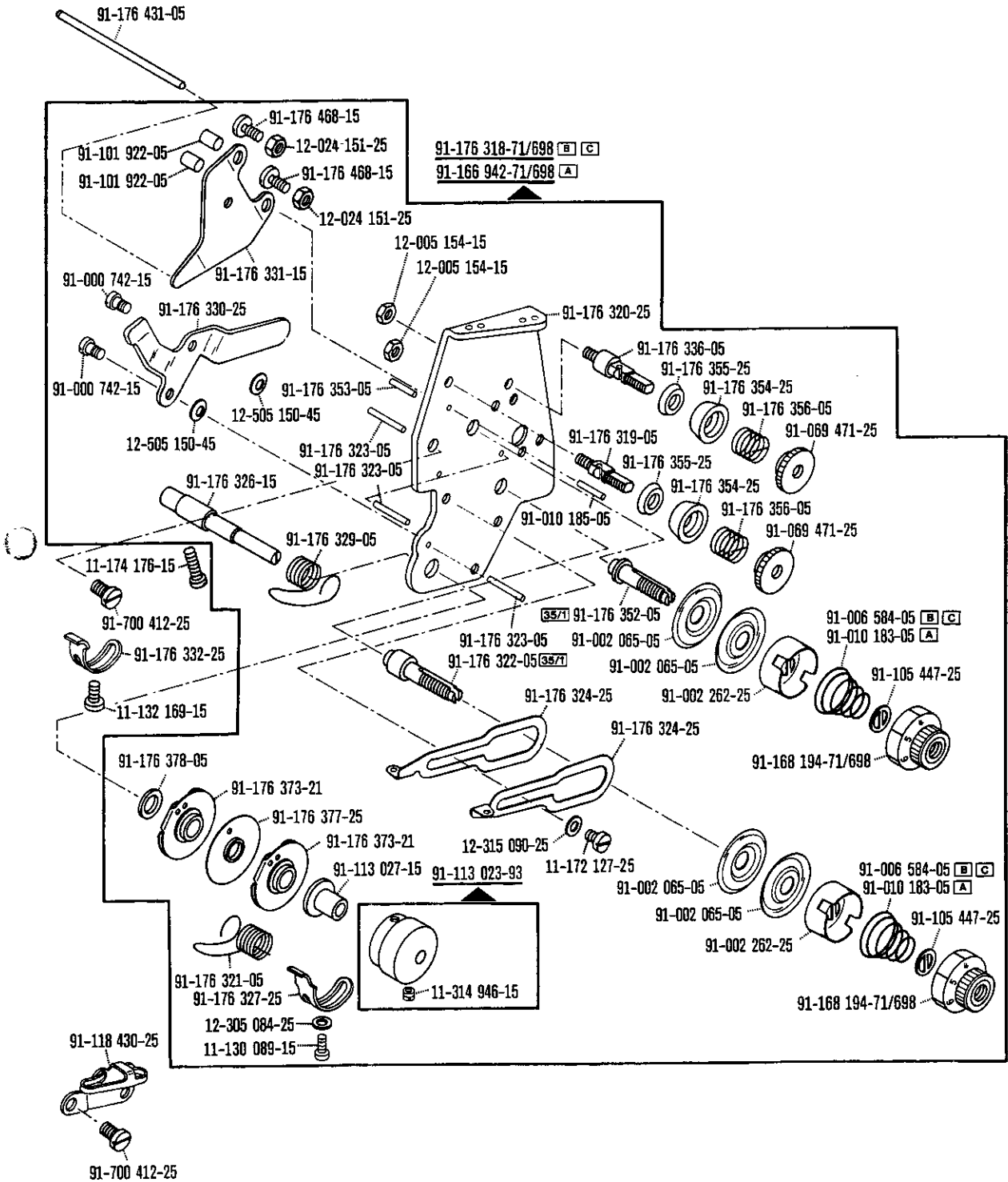

siehe Erläuterungen Register [A] [B] [C]
 see explanations in section [A] [B] [C]
 voir légende registre [A] [B] [C]
 ver explicaciones del registro [A] [B] [C]

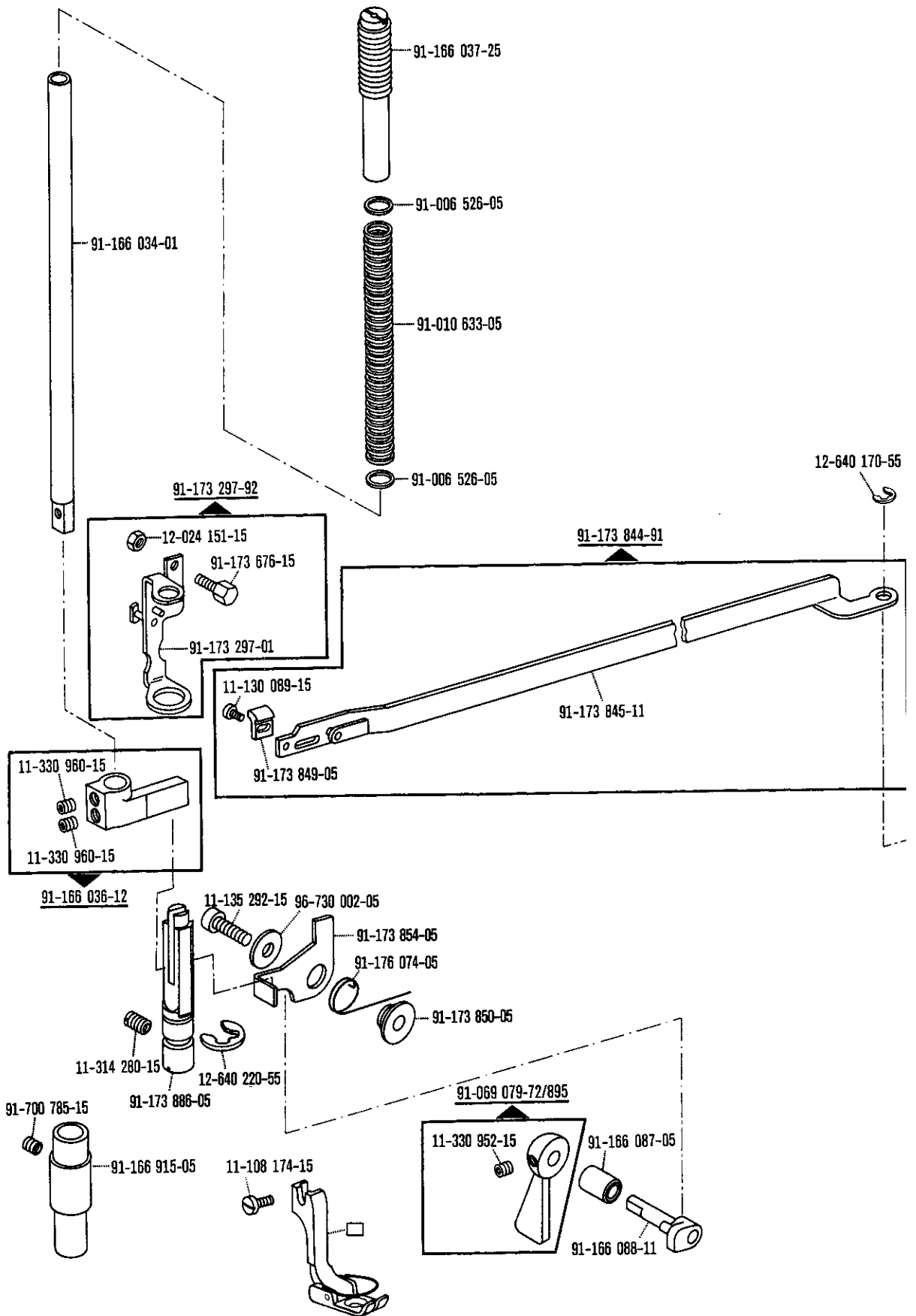

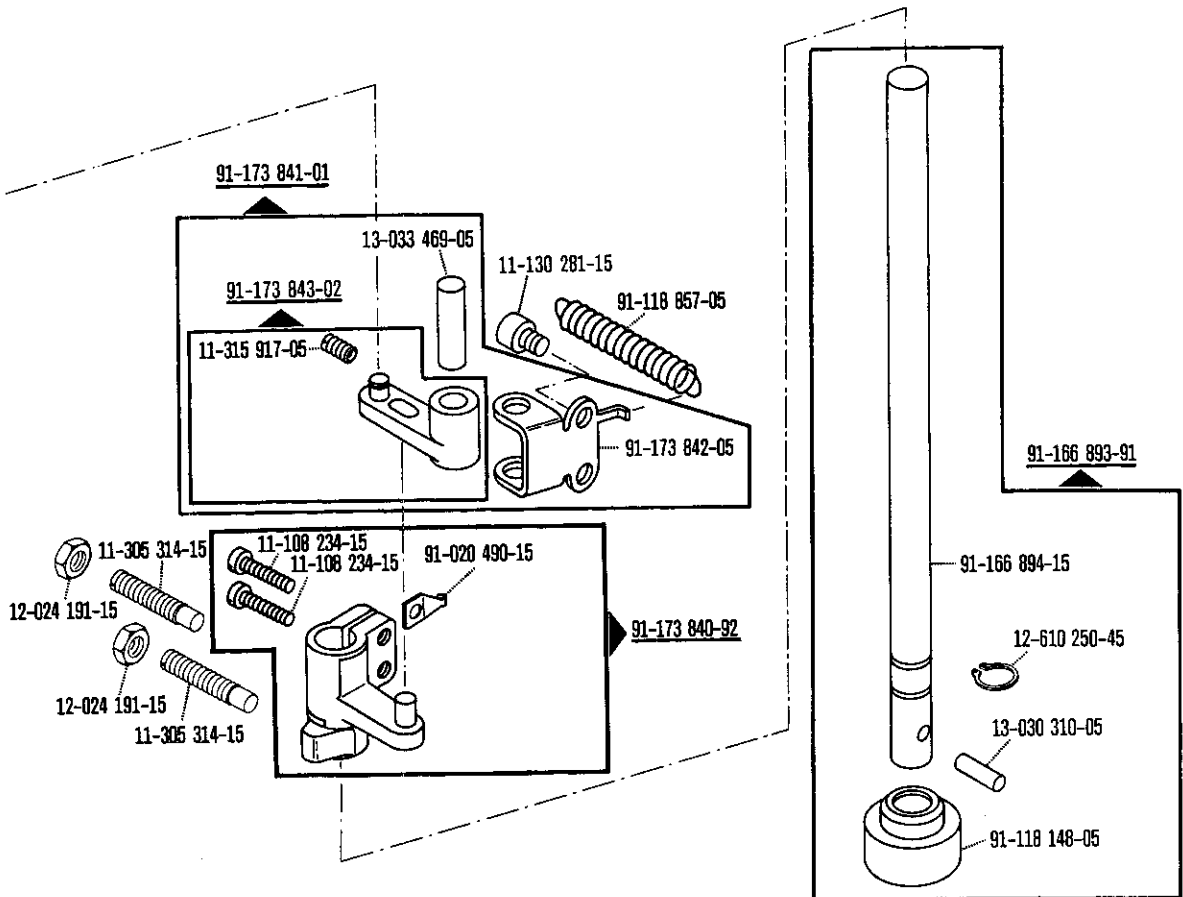
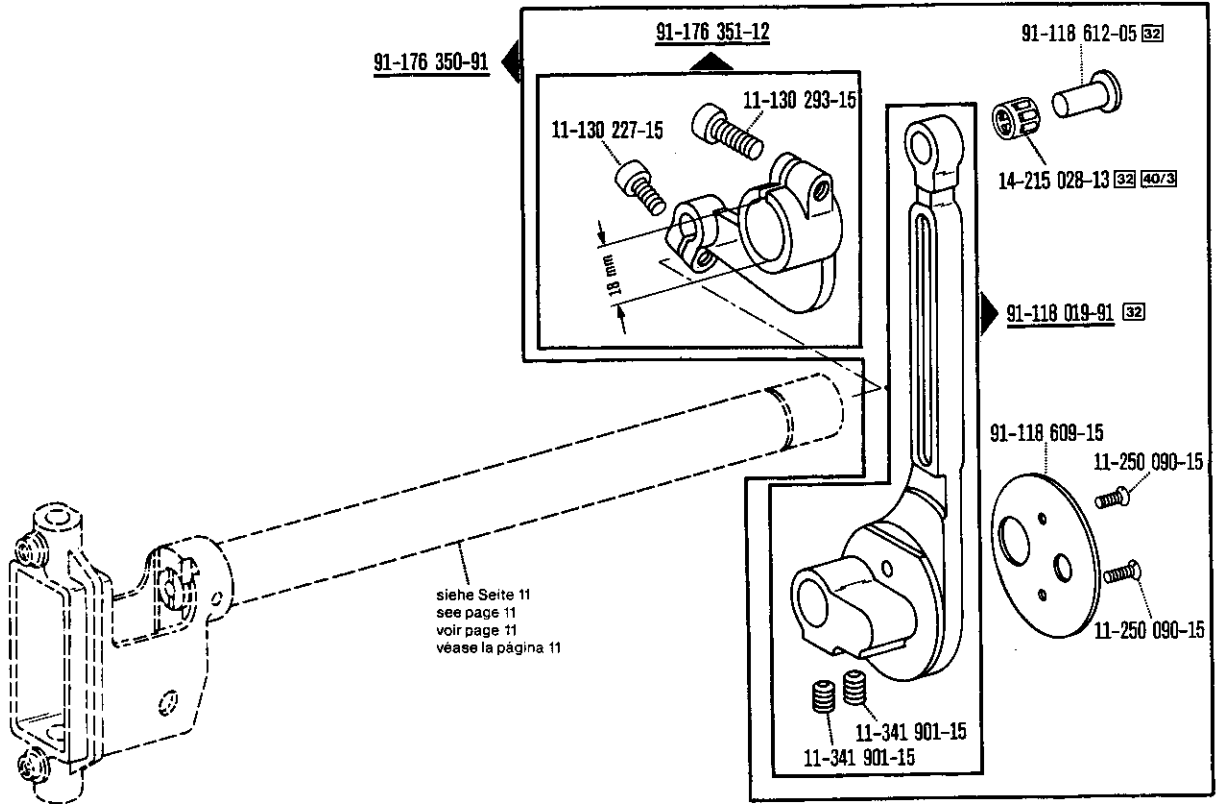

□ siehe Erläuterungen Register A-32
see explanations in section A-32
voir légende registre A-32
ver explicaciones del registro A-32

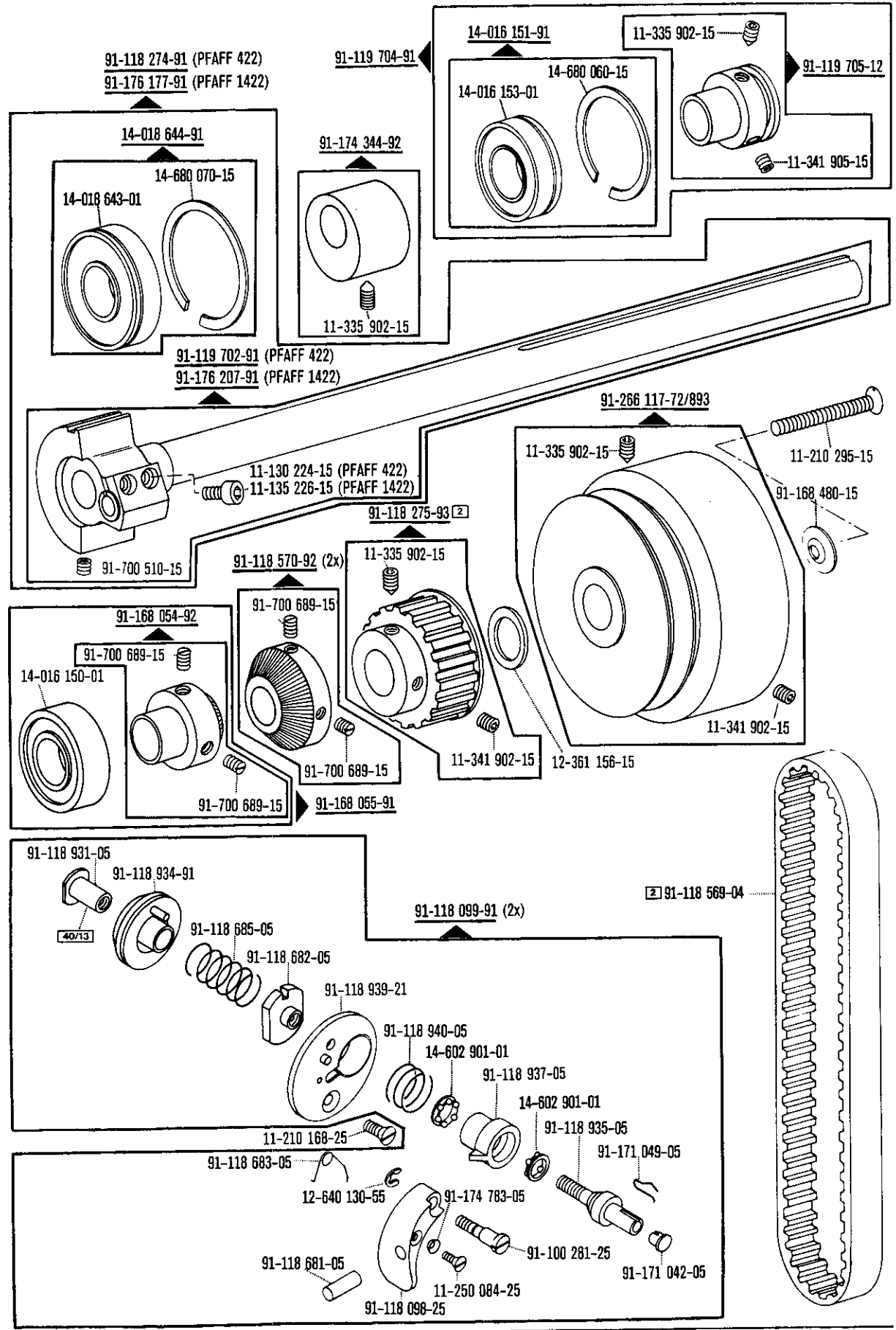

☐ siehe Erläuterungen Register [A] [B]
 see explanations in section [A] [B]
 voir légende registre [A] [B]
 ver explicaciones del registro [A] [B]

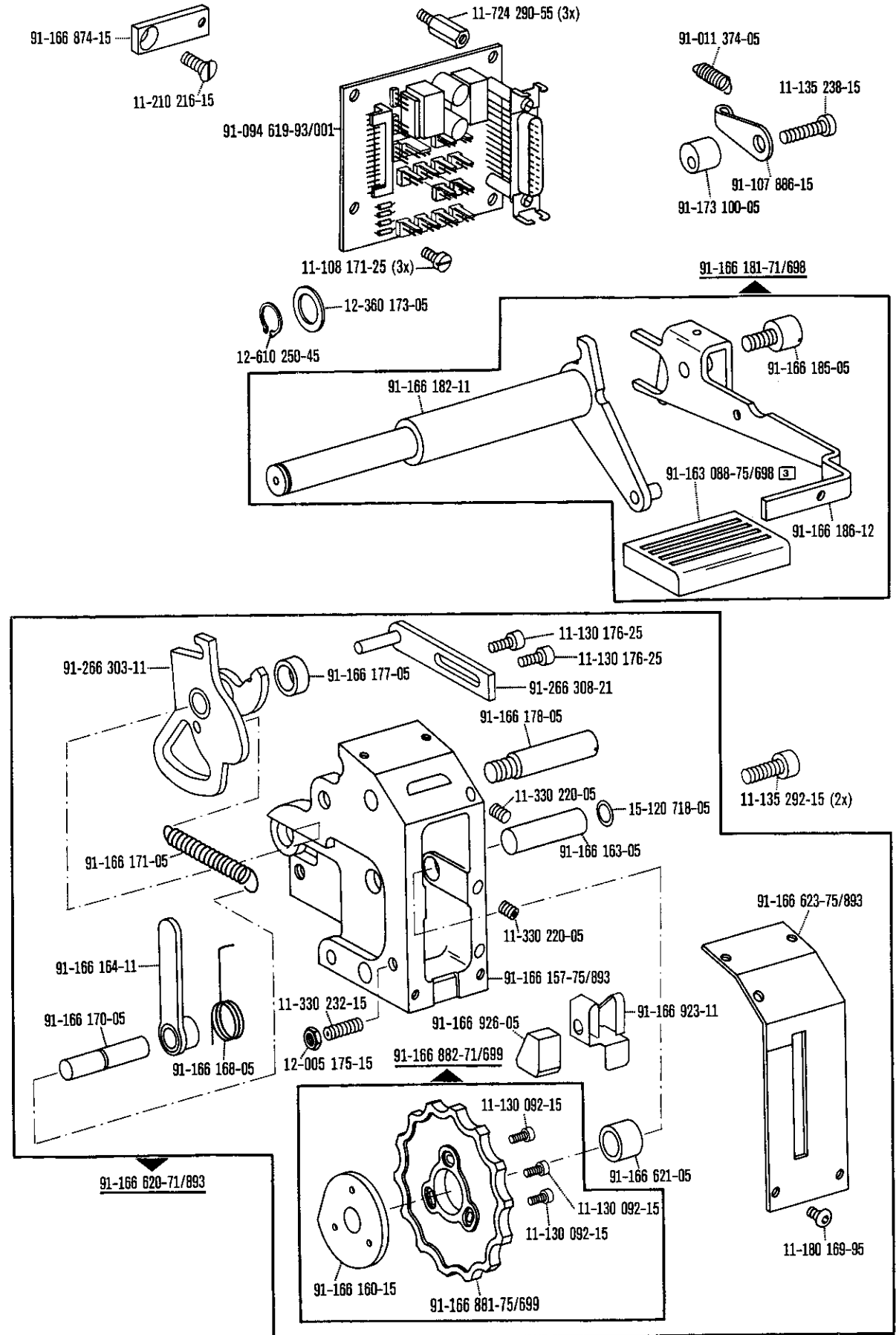

siehe Erläuterungen Register [A] - [99]
 see explanations in section [A] - [99]
 voir légende registre [A] - [99]
 ver explicaciones del registro [A] - [99]

Pieces du plateau fondamental
Piezas de la placa-base PFAFF 422

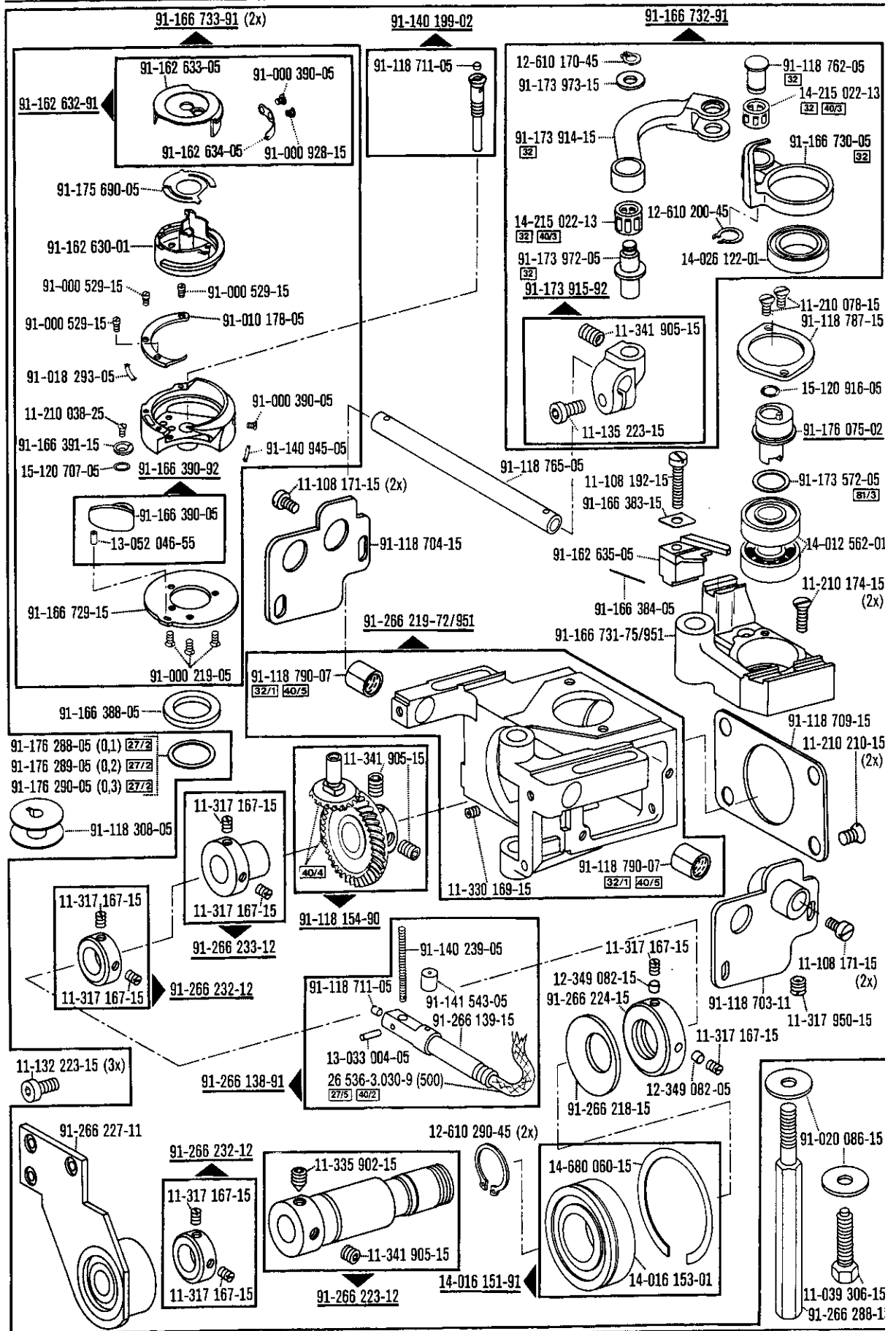

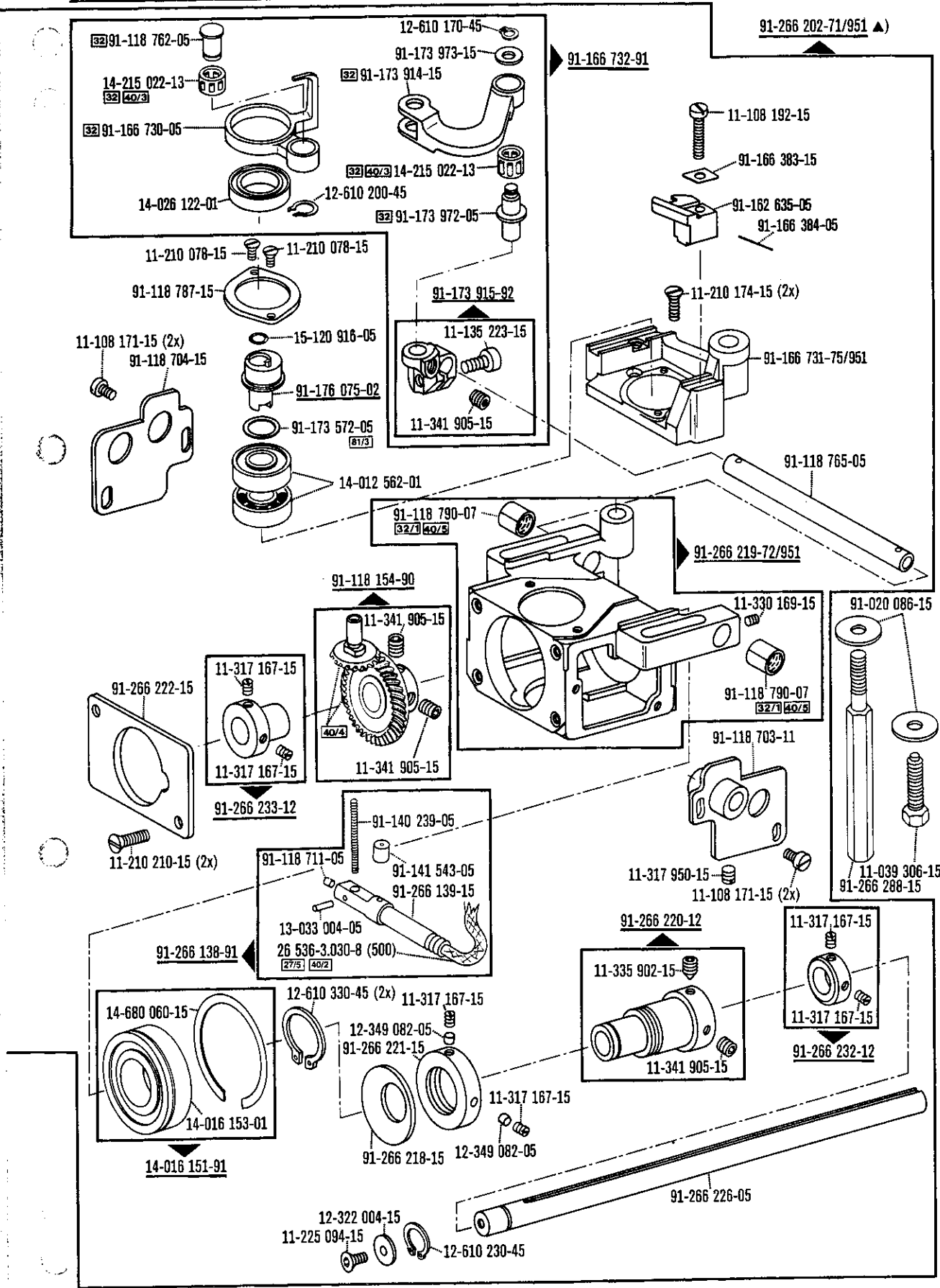

□ siehe Erläuterungen Register [A] [B]
 see explanations in section [A] [B]
 voir légende registre [A] [B]
 ver explicaciones del registro [A] [B]

▲ Für alle Maschinen ohne -900/.. und für Maschinen mit -720/..
 For all machines without -900/.. and for machines equipped with -720/..
 Pour toutes les machines sans -900/.. mais avec -720/..
 Para todas las máquinas sin -900/.. y para máquinas con -720/..

Pieces du plateau fondamental
Piezas de la placa-base PFAFF 1422

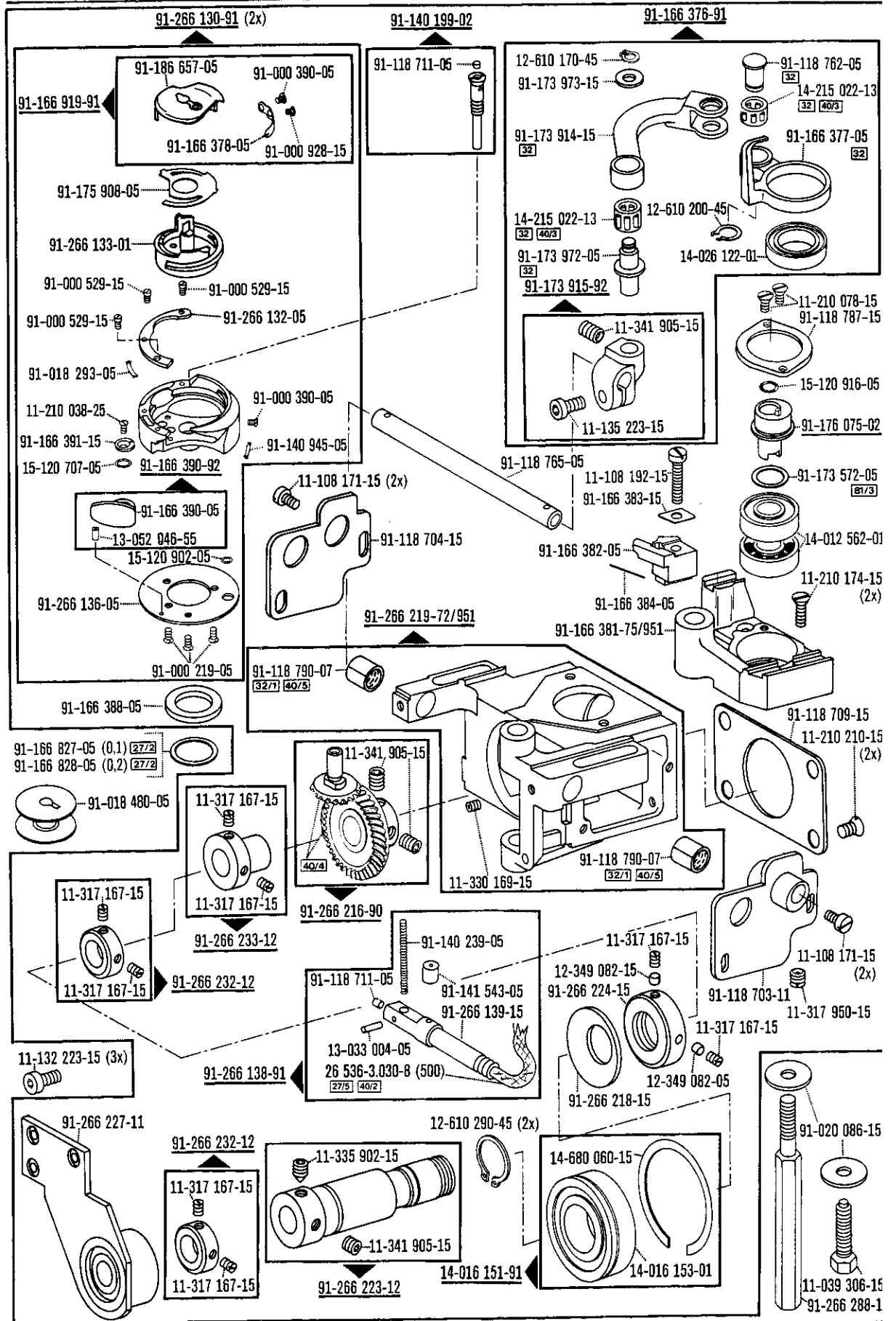

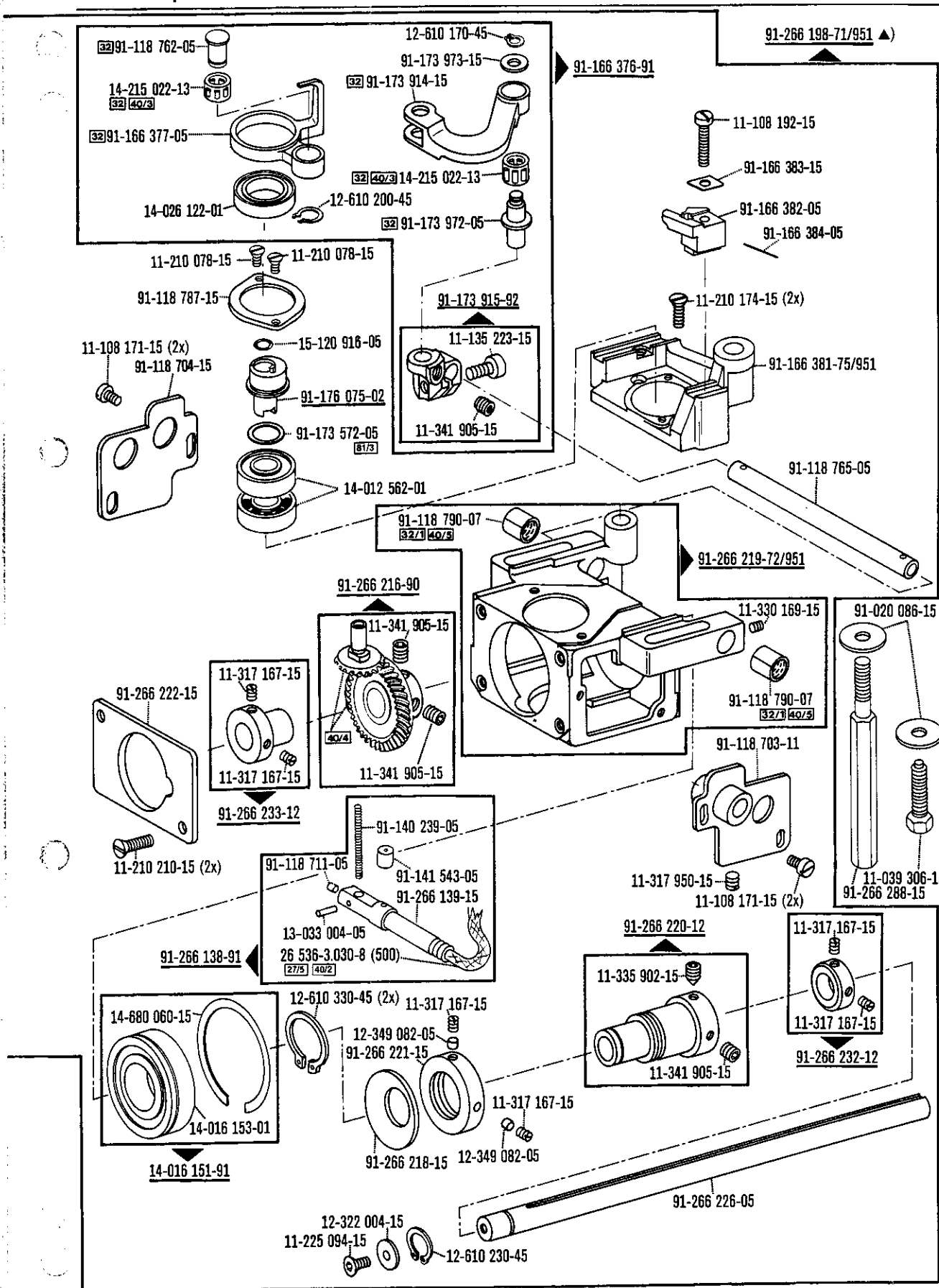

□ siehe Erläuterungen Register
 see explanations in section
 voir légende registre

▲ Für alle Maschinen ohne -900/.. und für Maschinen mit -720/.. bis 8 mm Nadelabstand
 For all machines without -900/.. and for machines equipped with -720/.. up to a needle gauge of 8 mm
 Pour toutes les machines sans -900/.. mais avec -720/.. jusqu'à 8 mm d'écartement des aiguilles
 Para todas las máquinas sin -900/.. y para máquinas con -720/.. hasta 8 mm distancia entre agujas

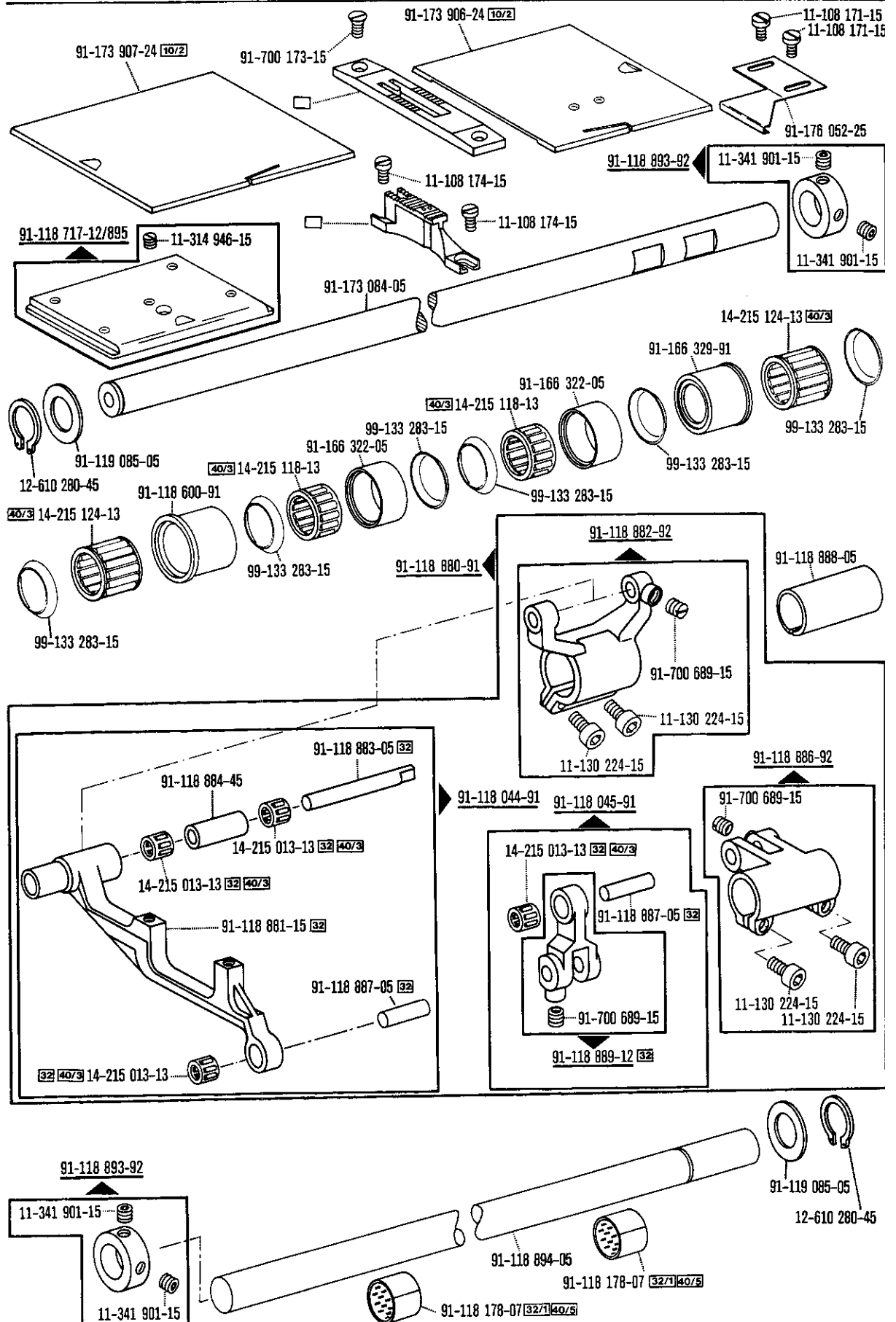

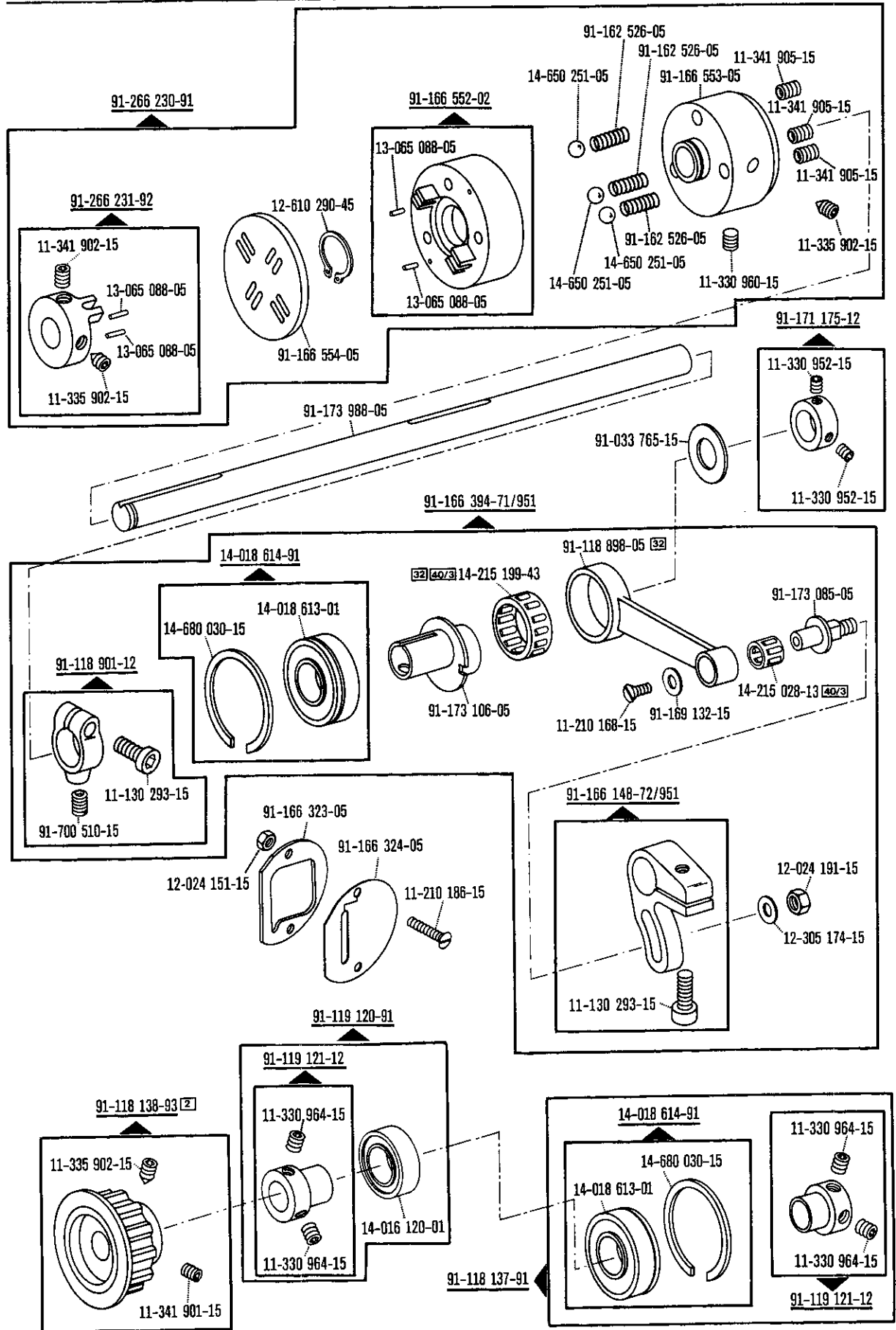

☐ siehe Erläuterungen Register [A] [B]
 see explanations in section [A] [B]
 voir légende registre [A] [B]

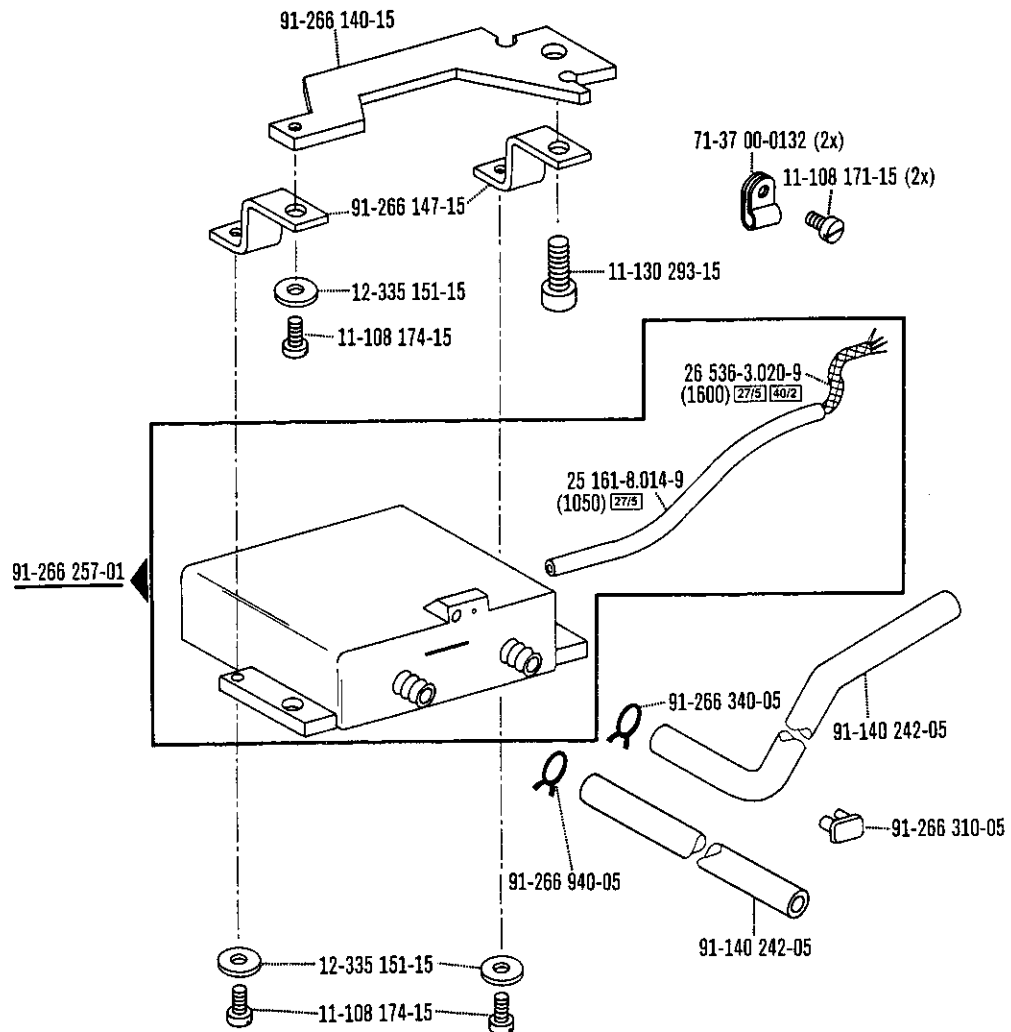

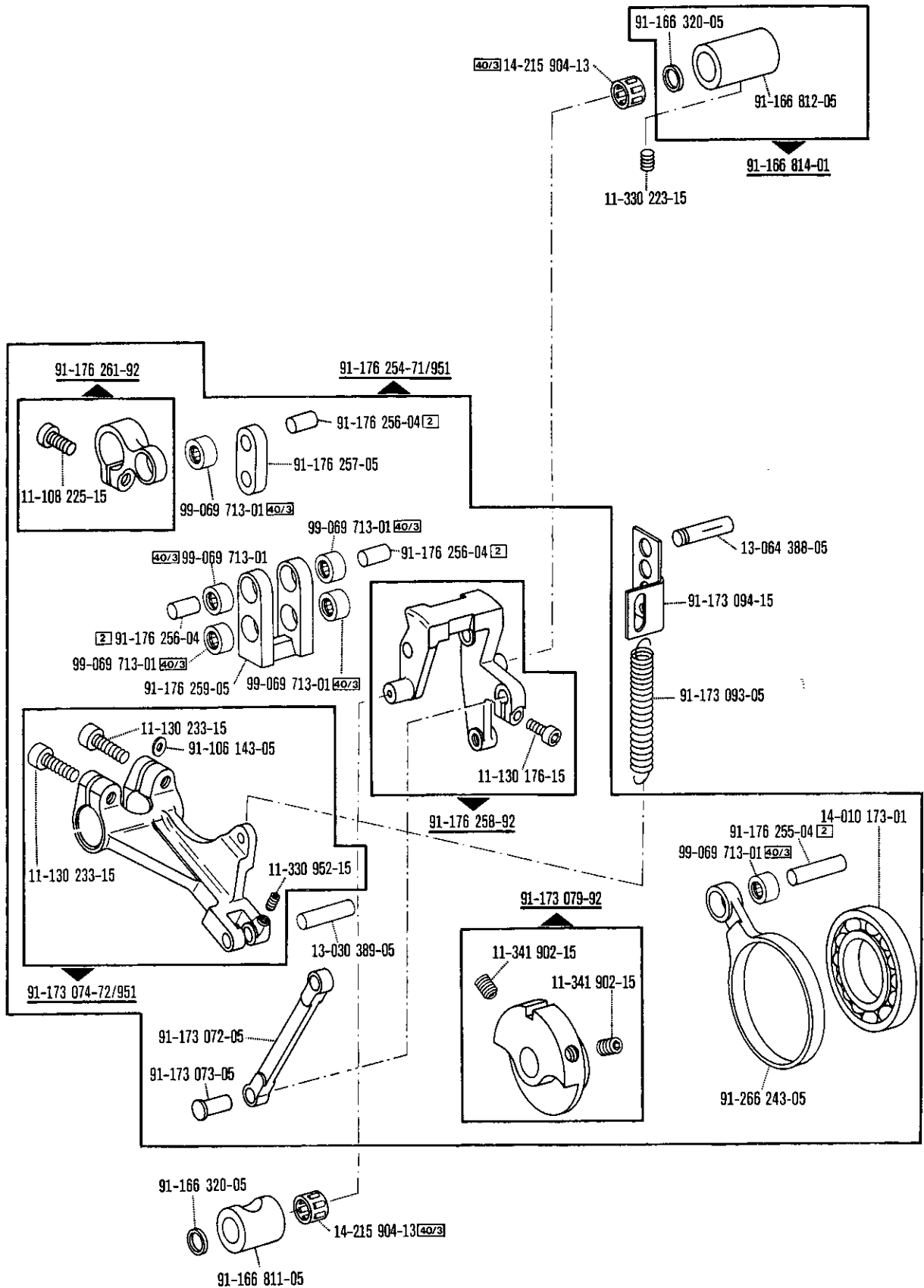

siehe Erläuterungen Register A-30
 see explanations in section A-30
 voir légende registre A-30
 ver explicaciones del registro A-30

Parties du corps PFAFF 422
 Piezas del cárter PFAFF 1422

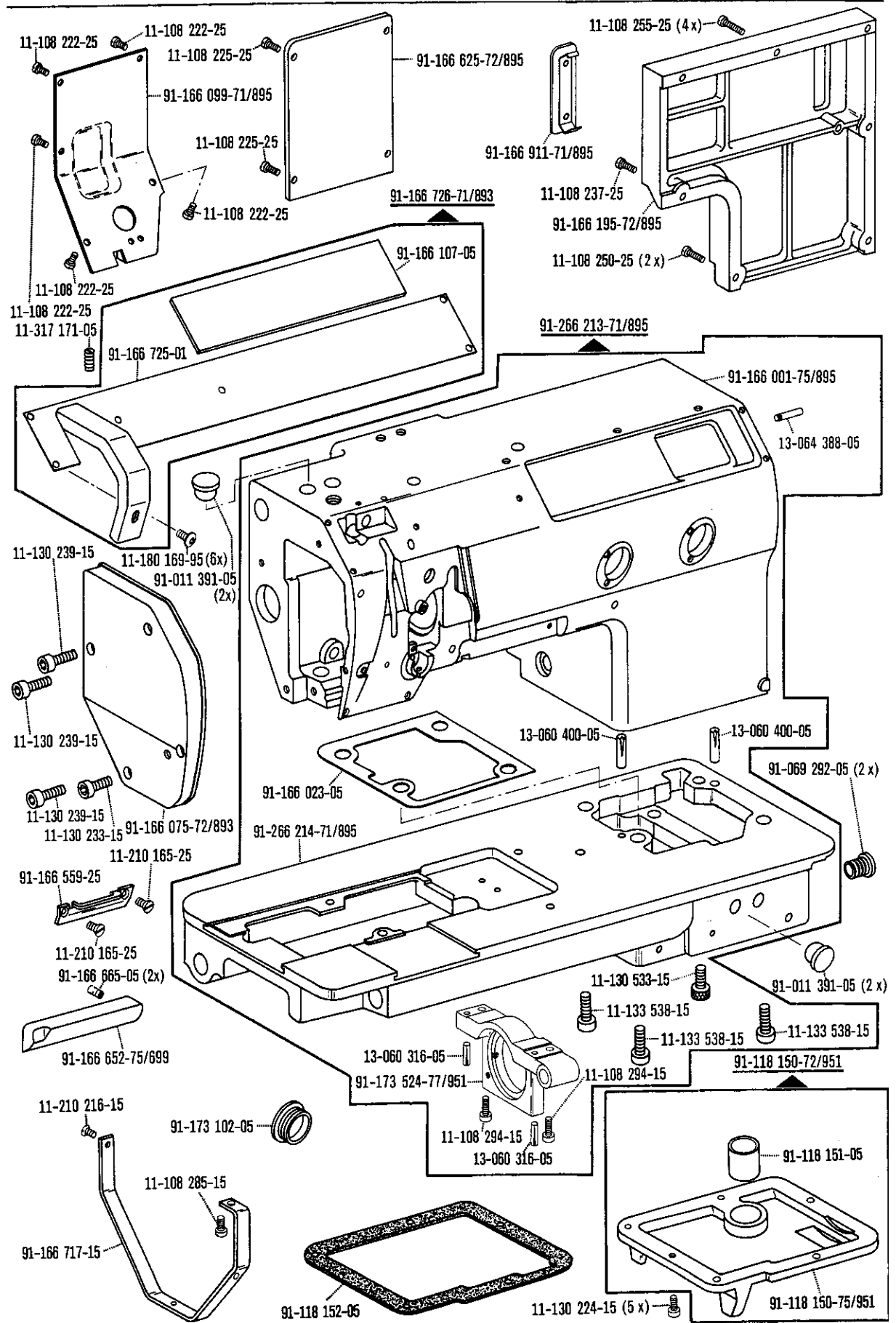

91-166 131-91 (PFAFF 422)

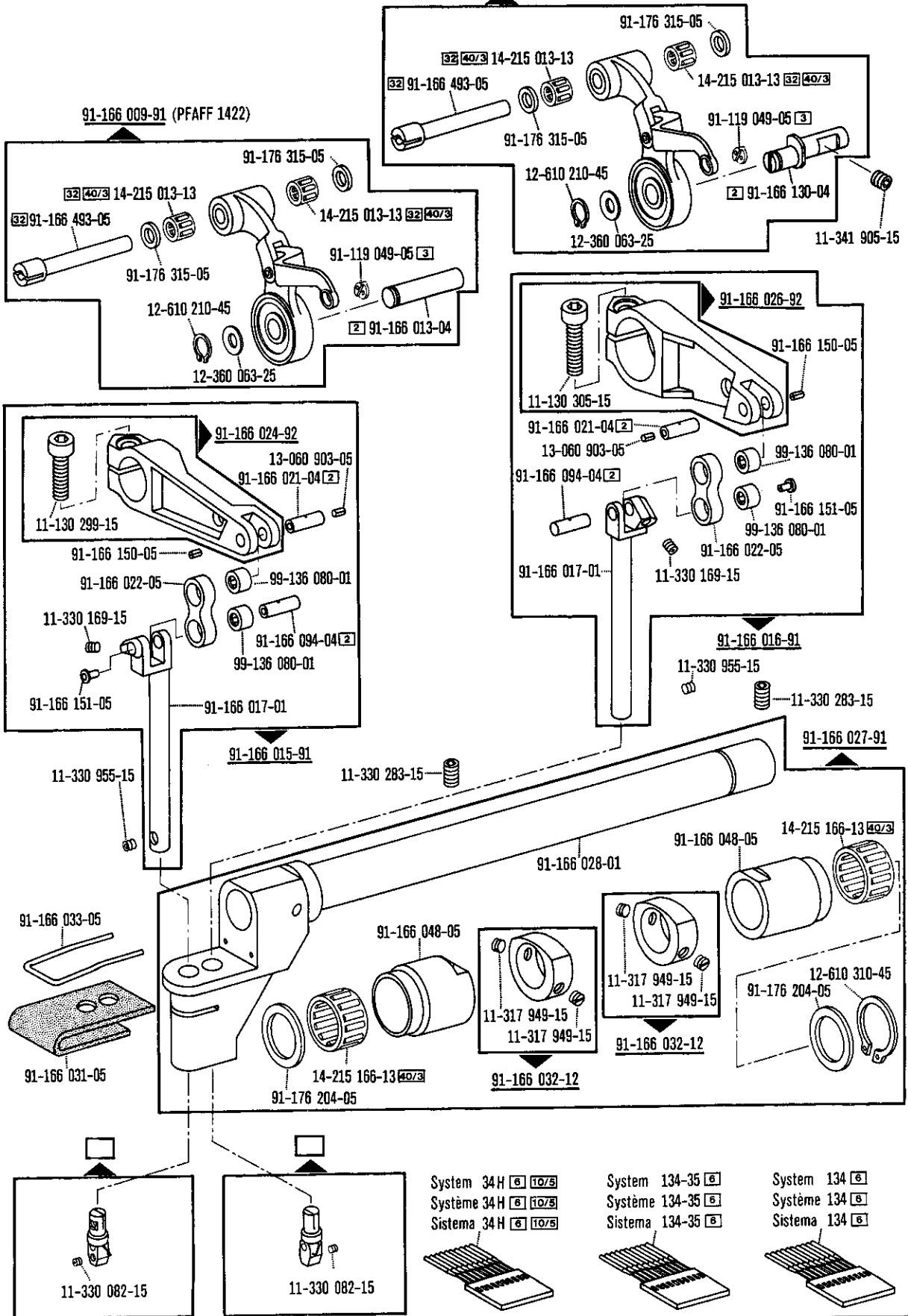

siehe Erläuterungen Register [A] - [B]
 see explanations in section [A] - [B]
 voir légende registre [A] - [B]
 ver explicaciones del registro [A] - [B]

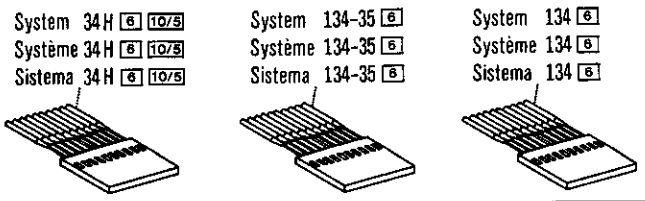

Barra de aguja desconectable a izquierda y derecha -720/04 for para PFAFF 1422

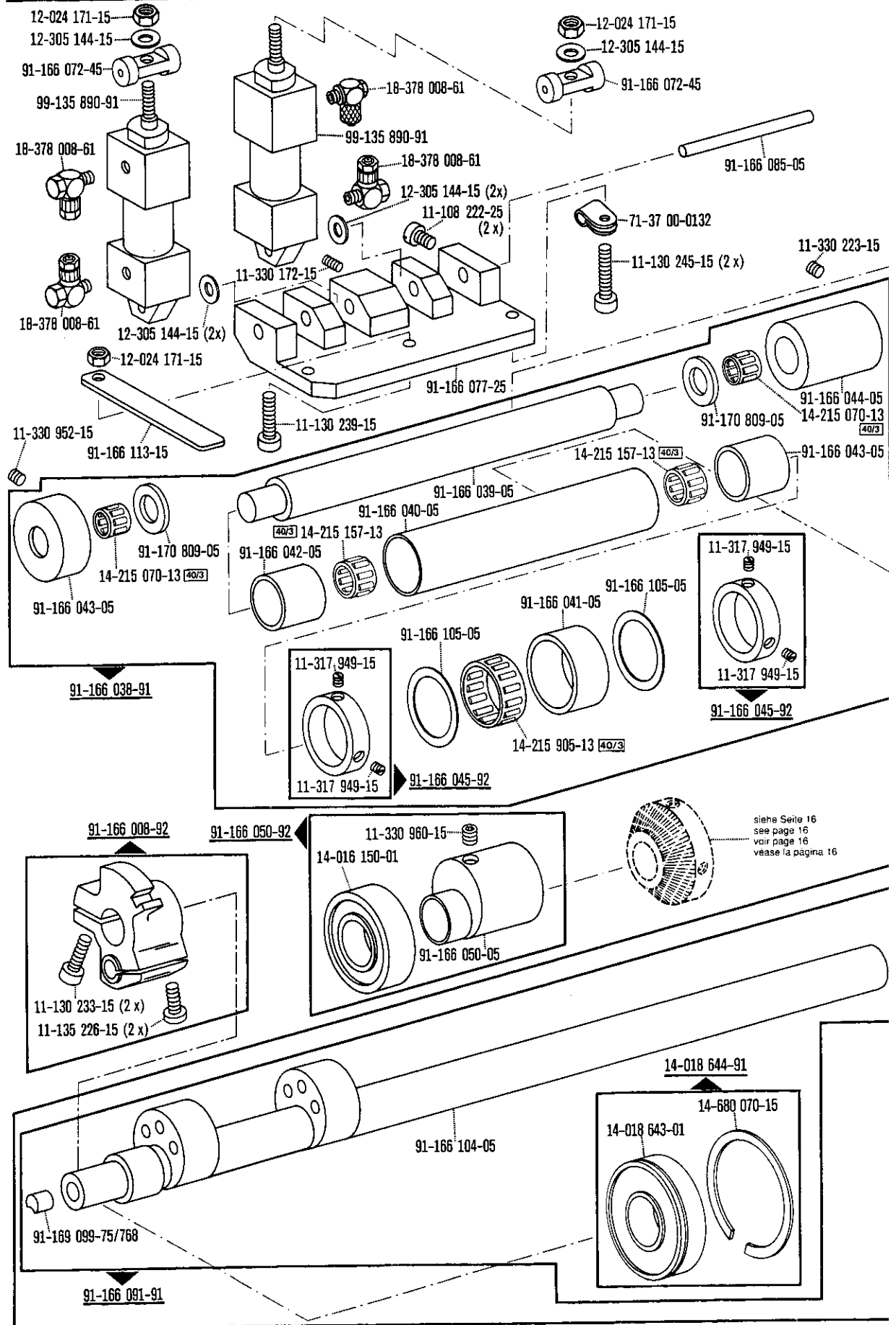

siehe Seite 16
see page 16
voir page 16
vease la pagina 16

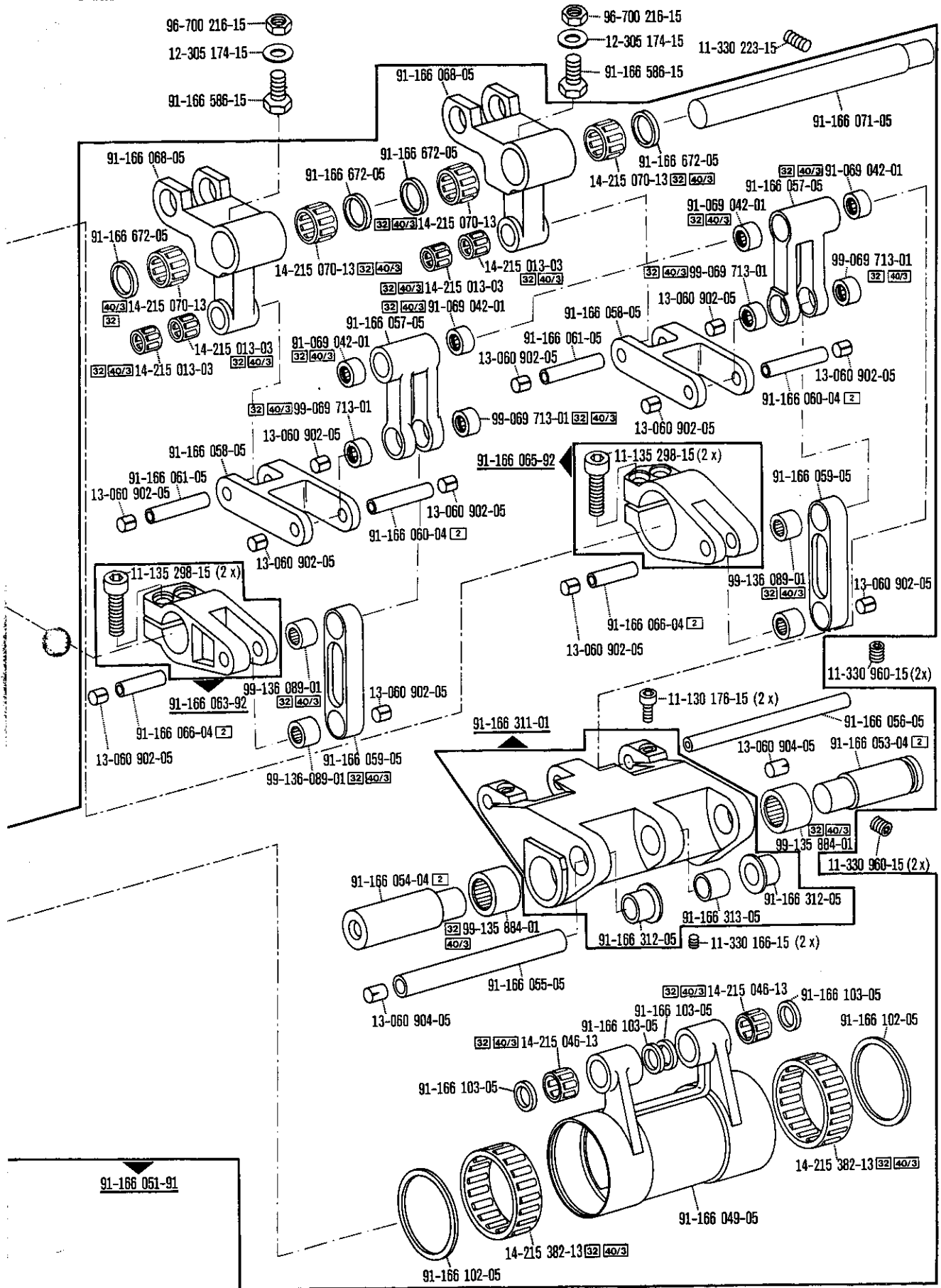

□ siehe Erläuterungen Register
 see explanations in section
 voir légende registre

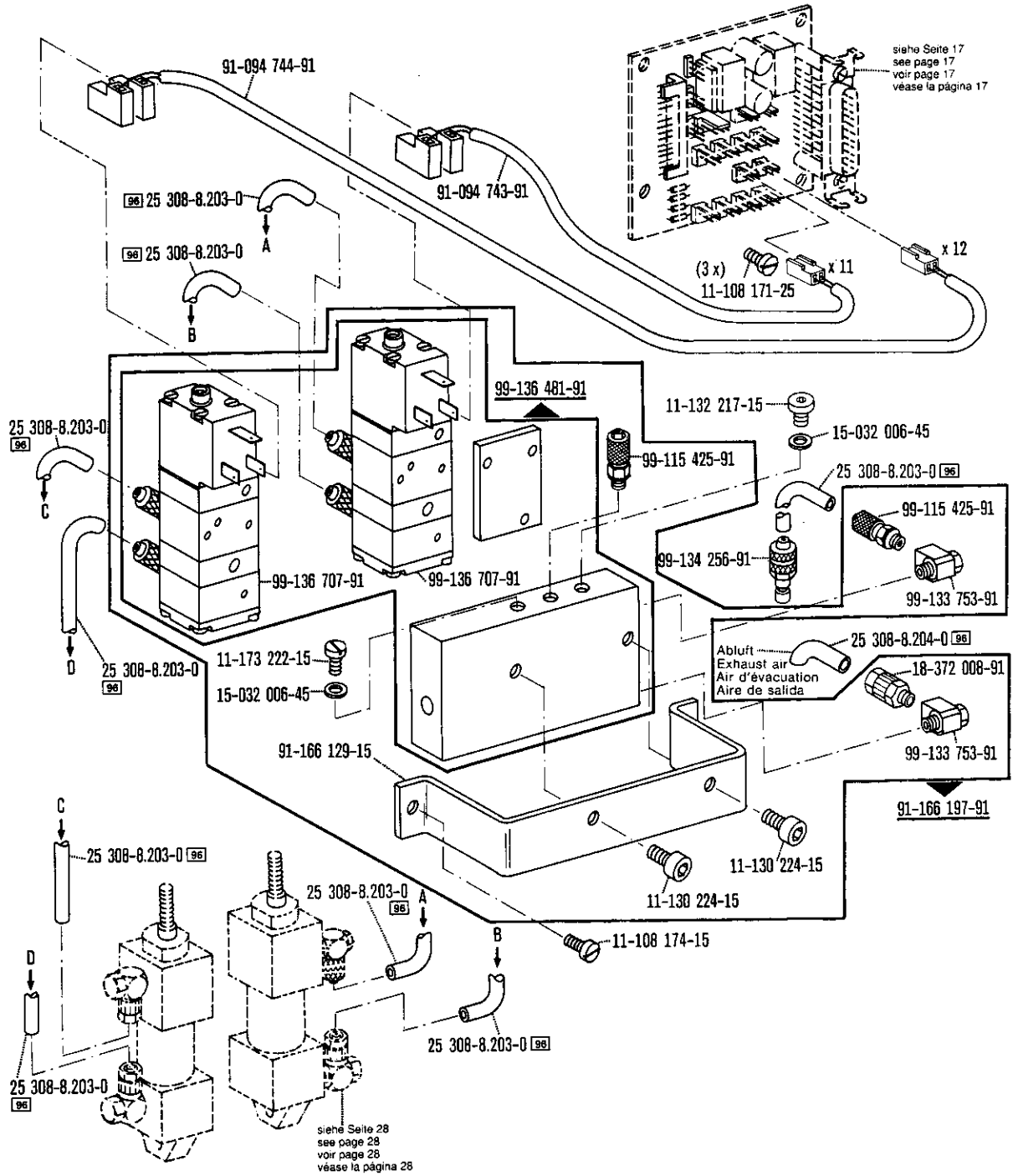

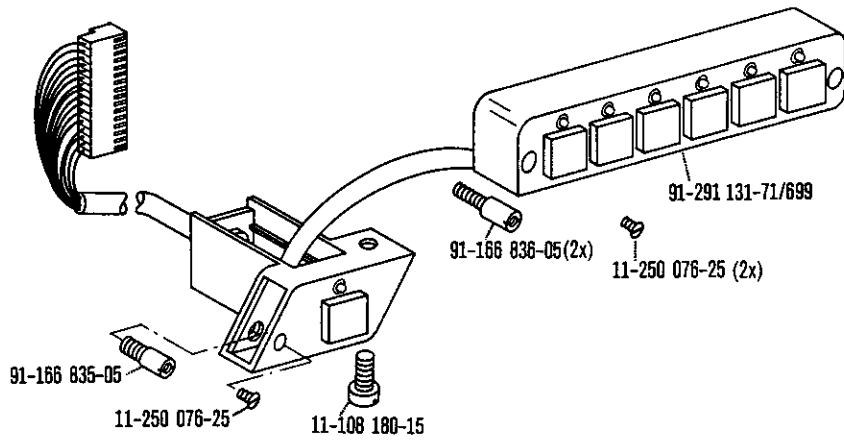

Tastenkappe Cap Calotte Tapa	Teile-Nr. Part No. Référence No de pieza	Tastenkappe Cap Calotte Tapa	Teile-Nr. Part No. Référence No de pieza
	71-13 00-0591		71-13 00-0595
	71-13 00-0592		71-13 00-0596
	71-13 00-0593		71-13 00-0599
	71-13 00-0594		71-13 00-0602

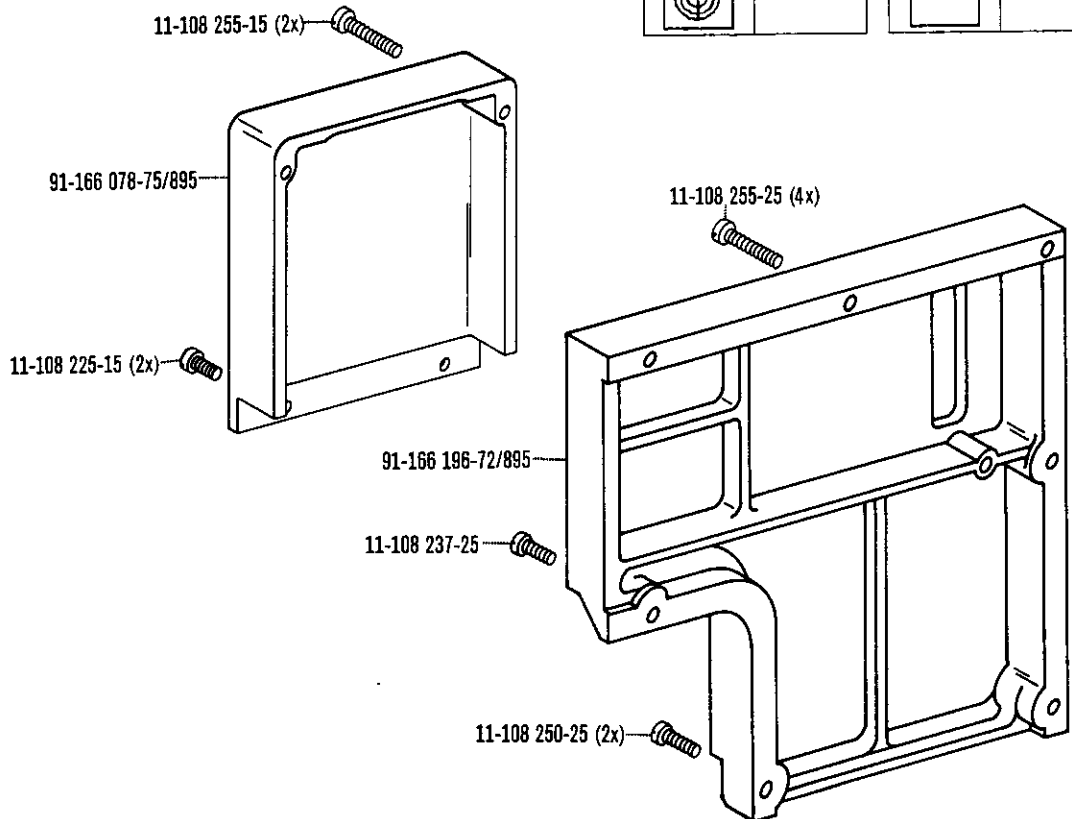

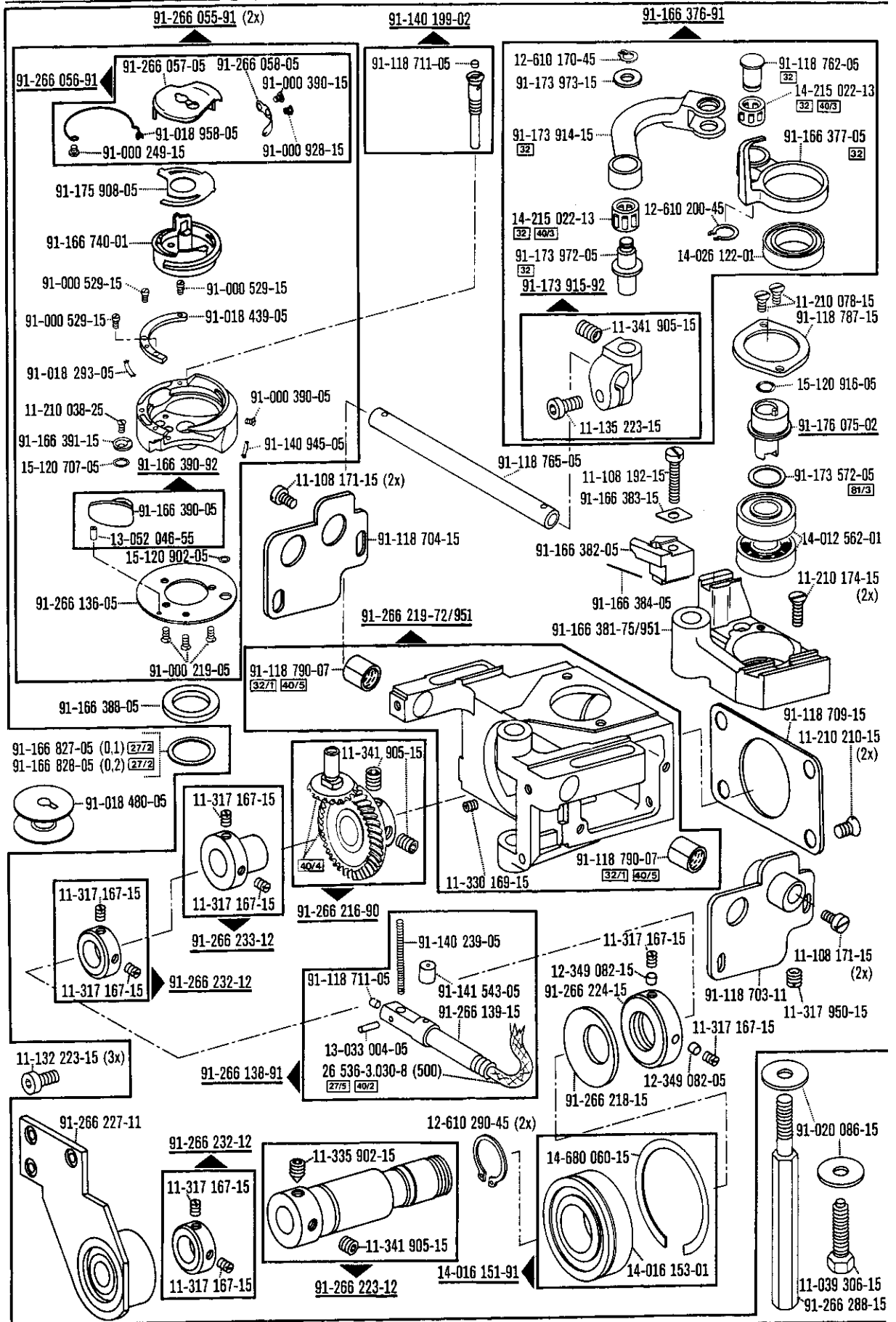

Disengageable right and left needles
 Commande de barres à aiguilles
 Barra de aguja desconectable a izquierda y derecha -720/04 zur - part
 for - part PFAFF 1422 ▲

-720/..

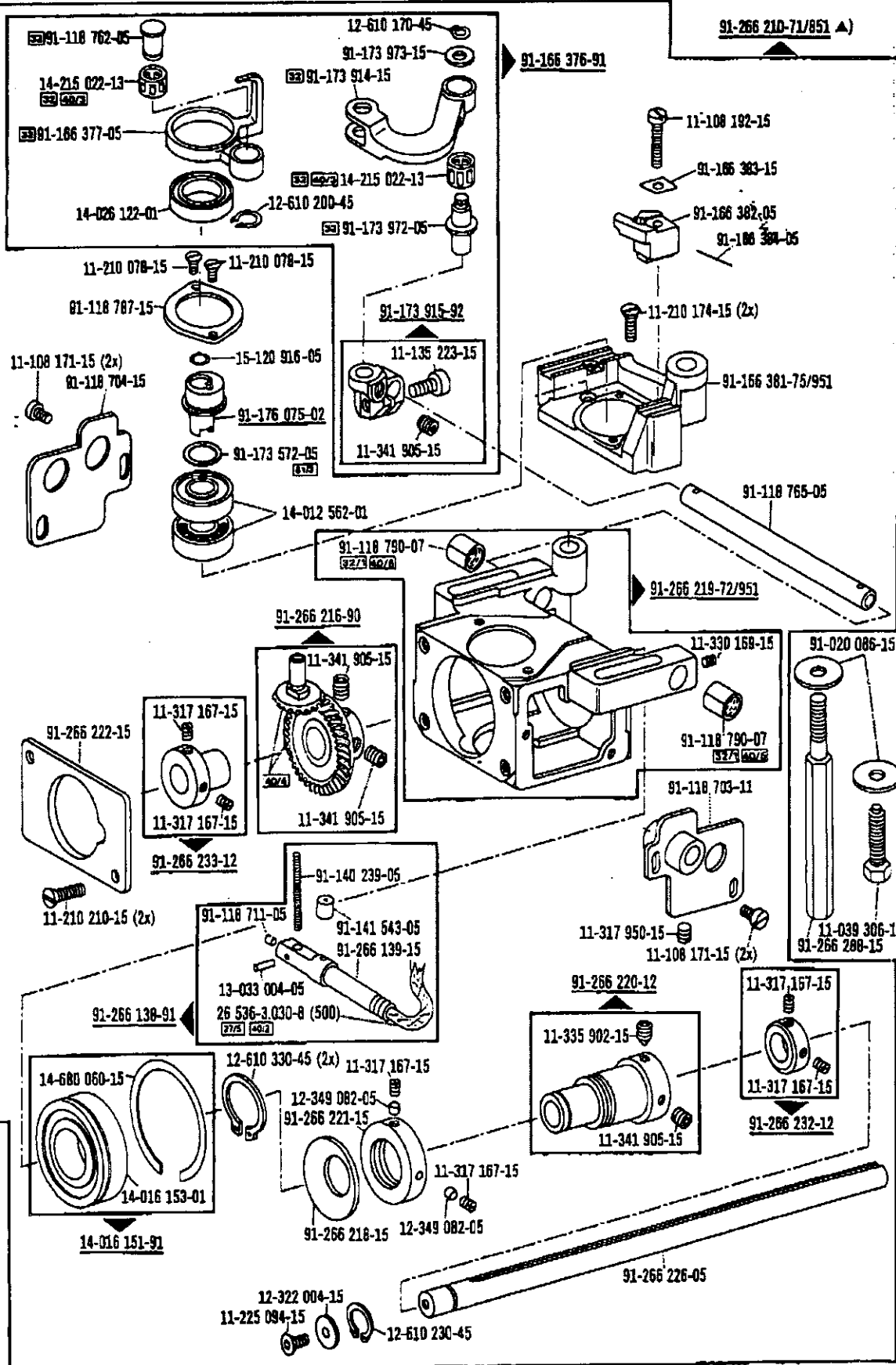

☐ siehe Erläuterungen Register see explanations in section voir légende registre
 ▲ Für Nadelabstand ab 6,0 mm ohne -900/.. For needle gauge with 6.0 mm without -900/.. Pour écartement des aiguilles du 6.0 mm sans -900/..

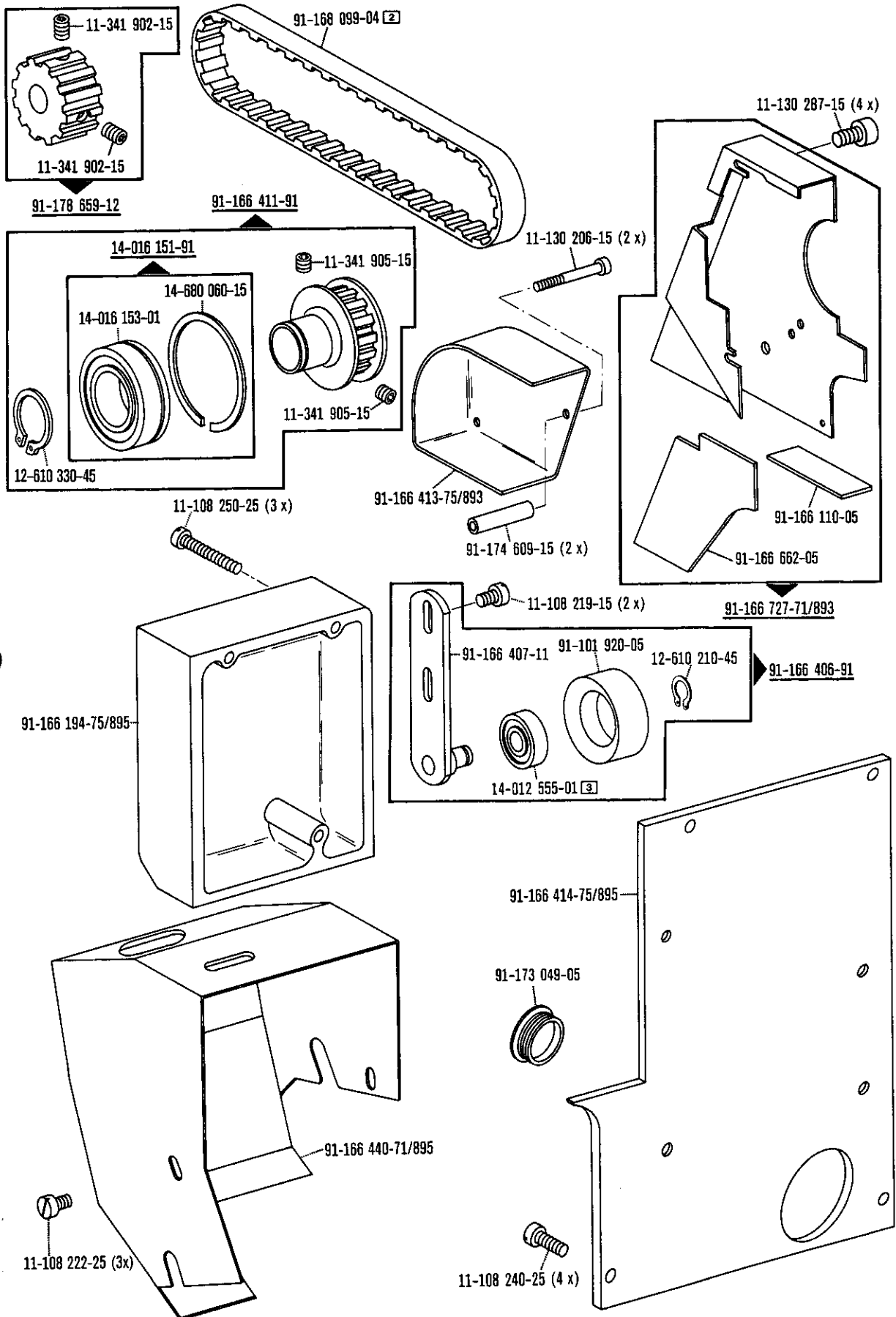

□ siehe Erläuterungen Register [A] · [30]
see explanations in section [A] · [30]
voir légende registre [A] · [30]

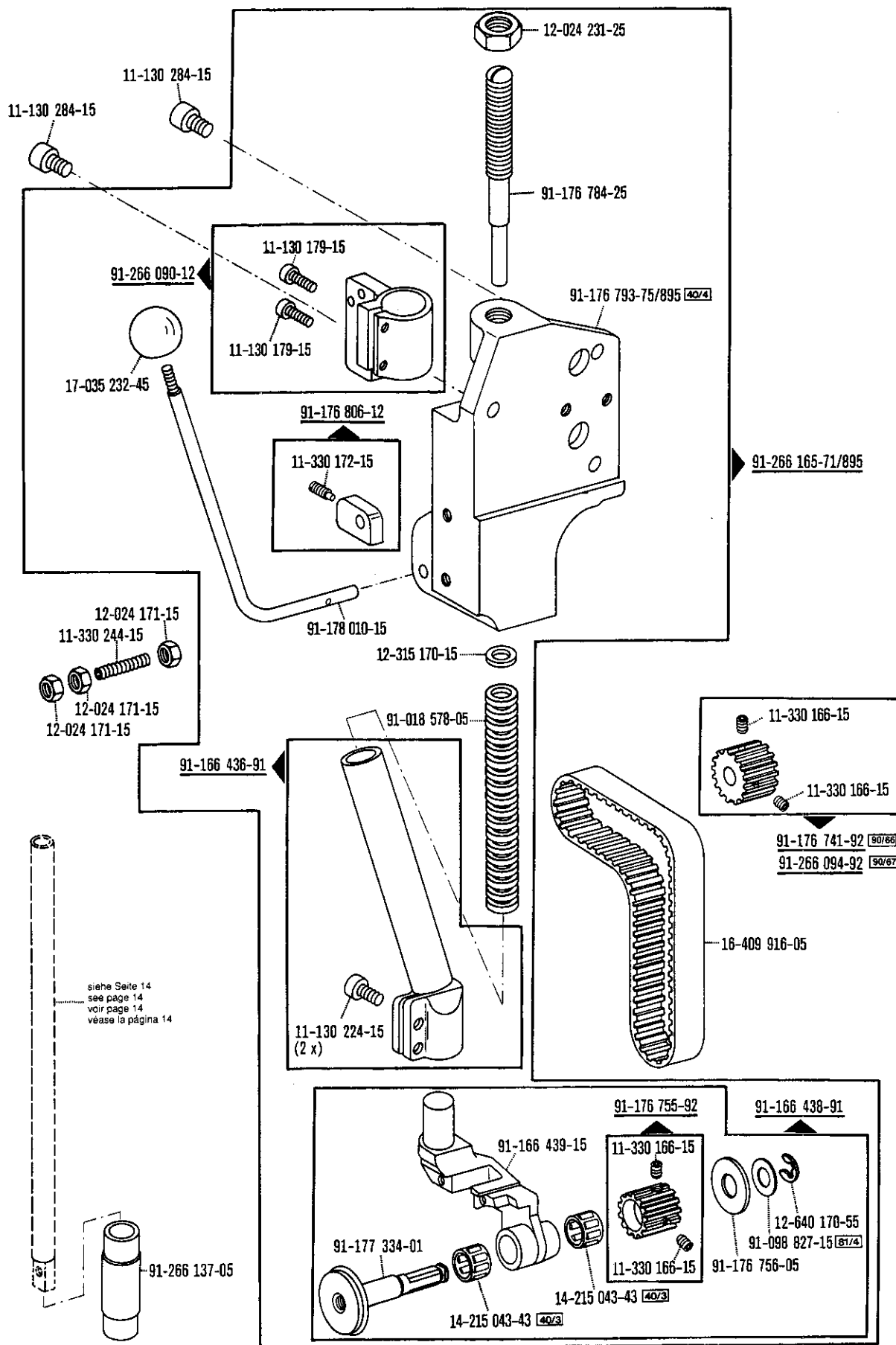

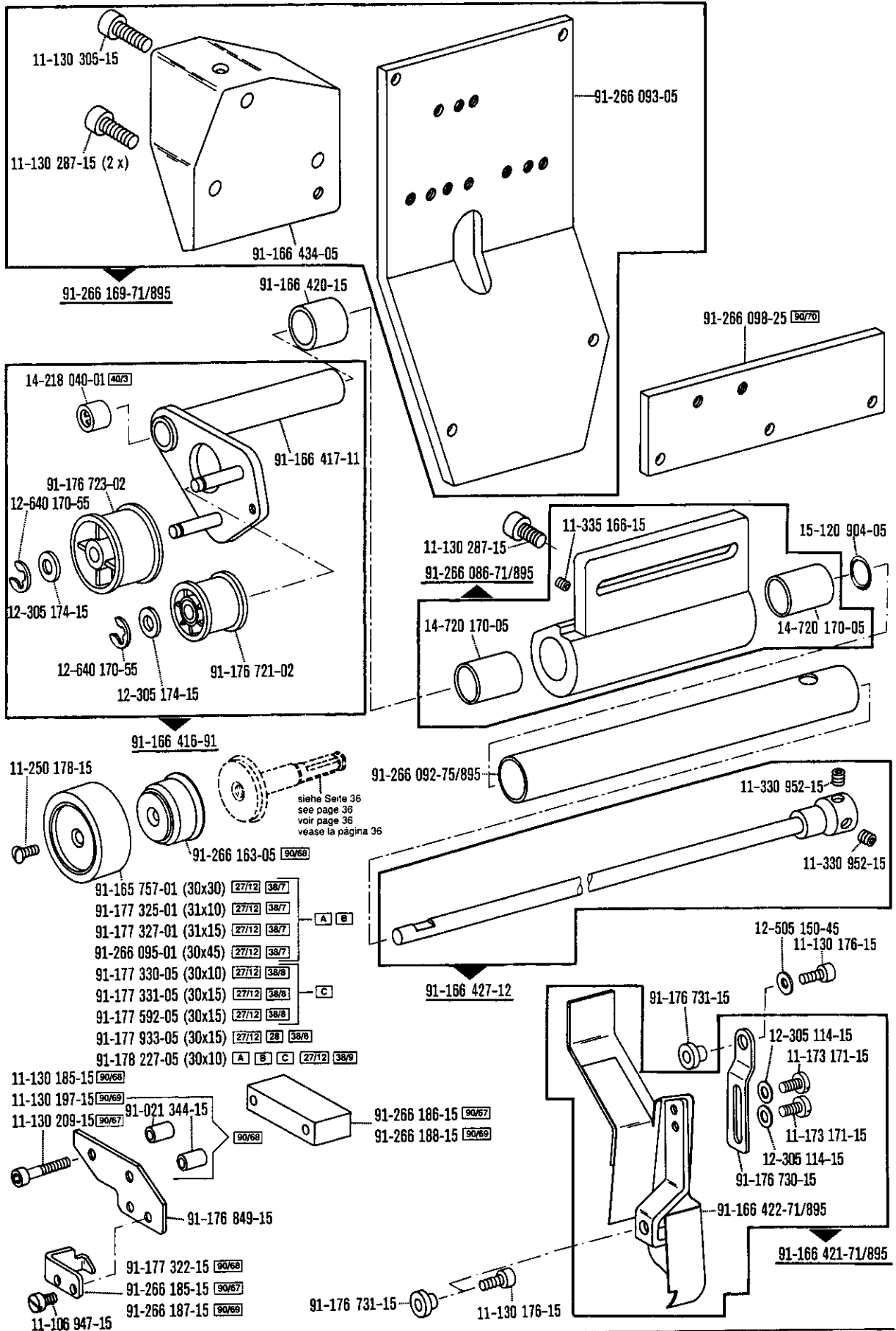

□ siehe Erläuterungen Register A - [28]
see explanations in section A - [28]
voir légende registre A - [28]

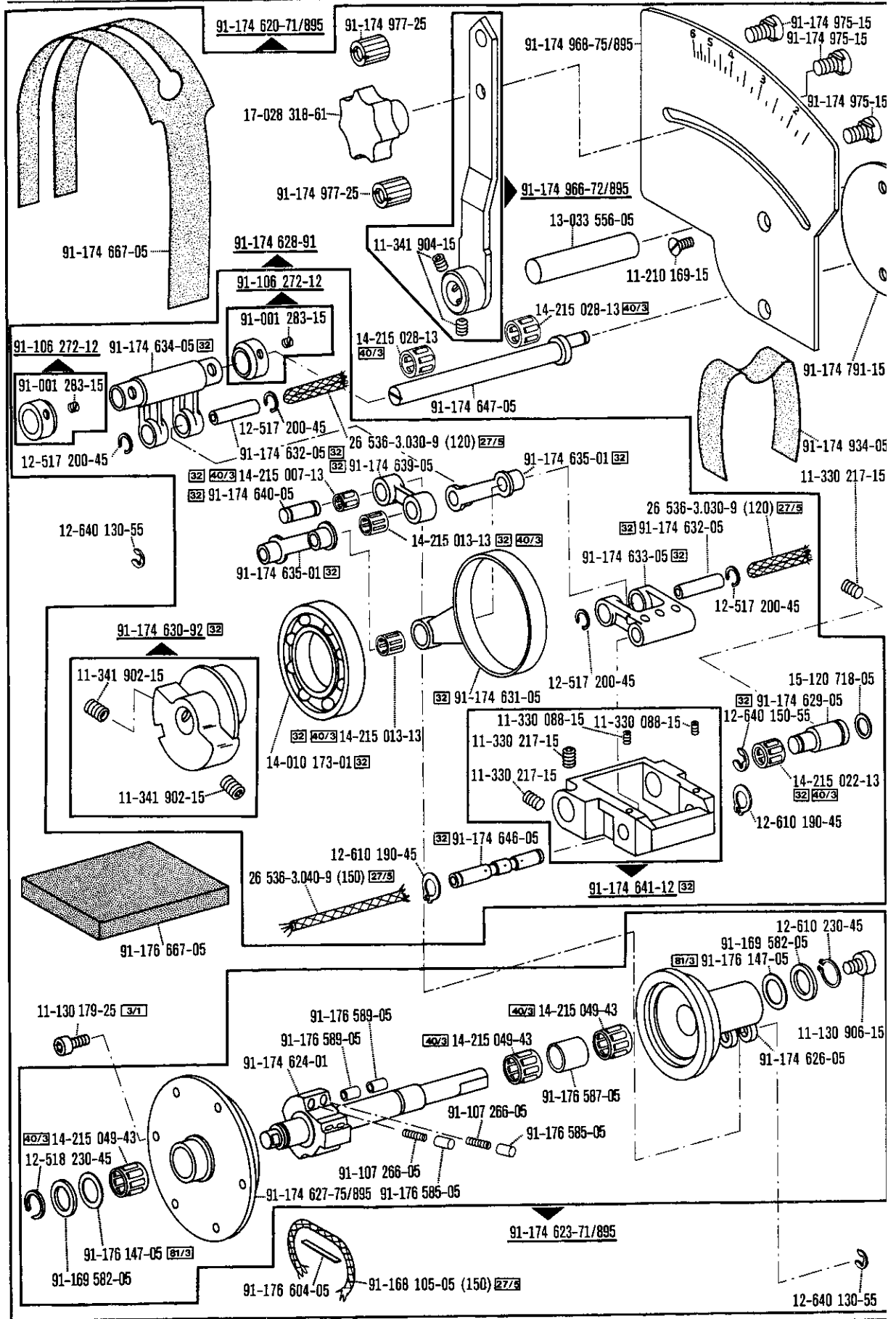

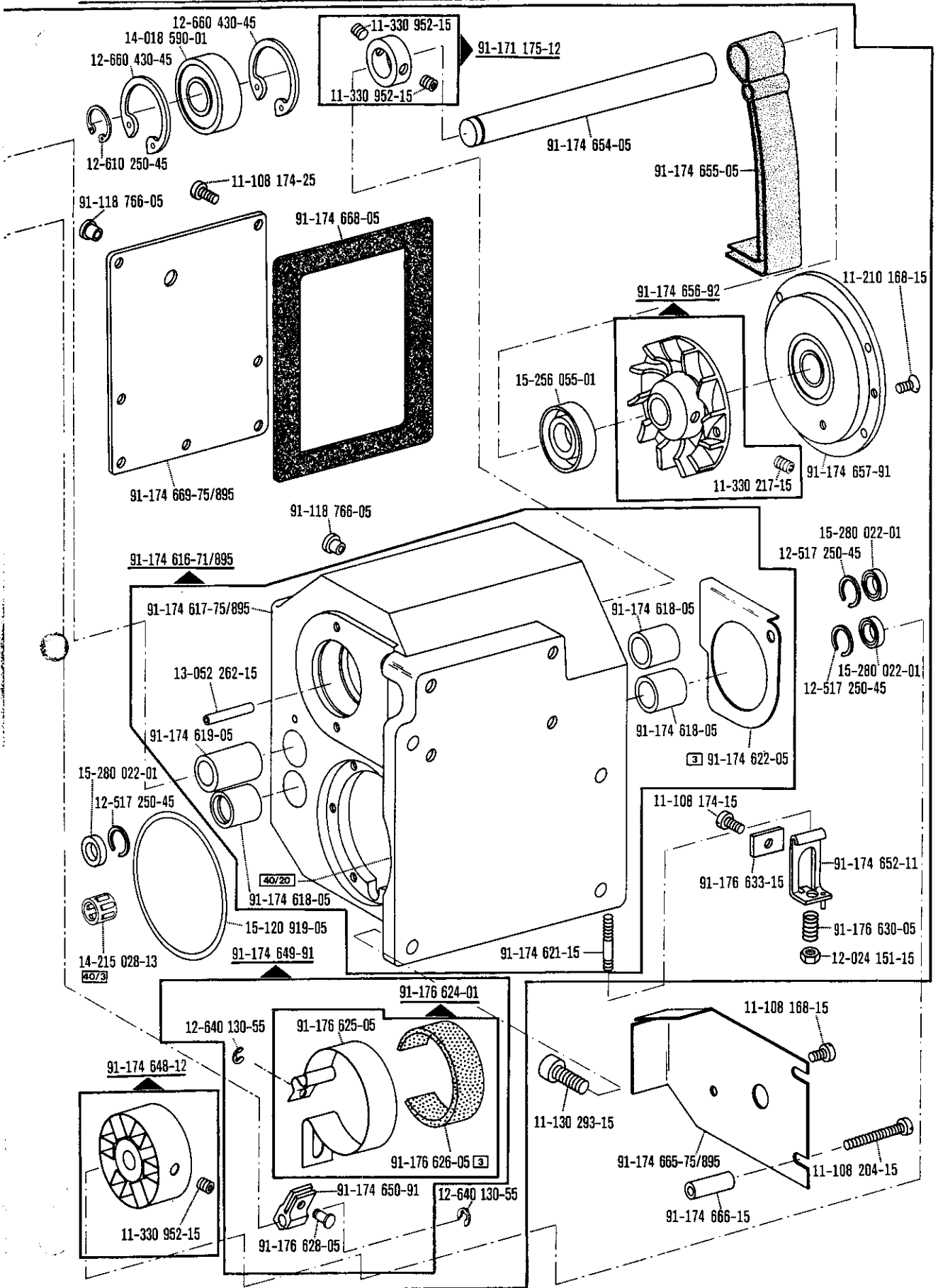

siehe Erläuterungen Register A - B
 see explanations in section A - B
 voir légende registre A - B

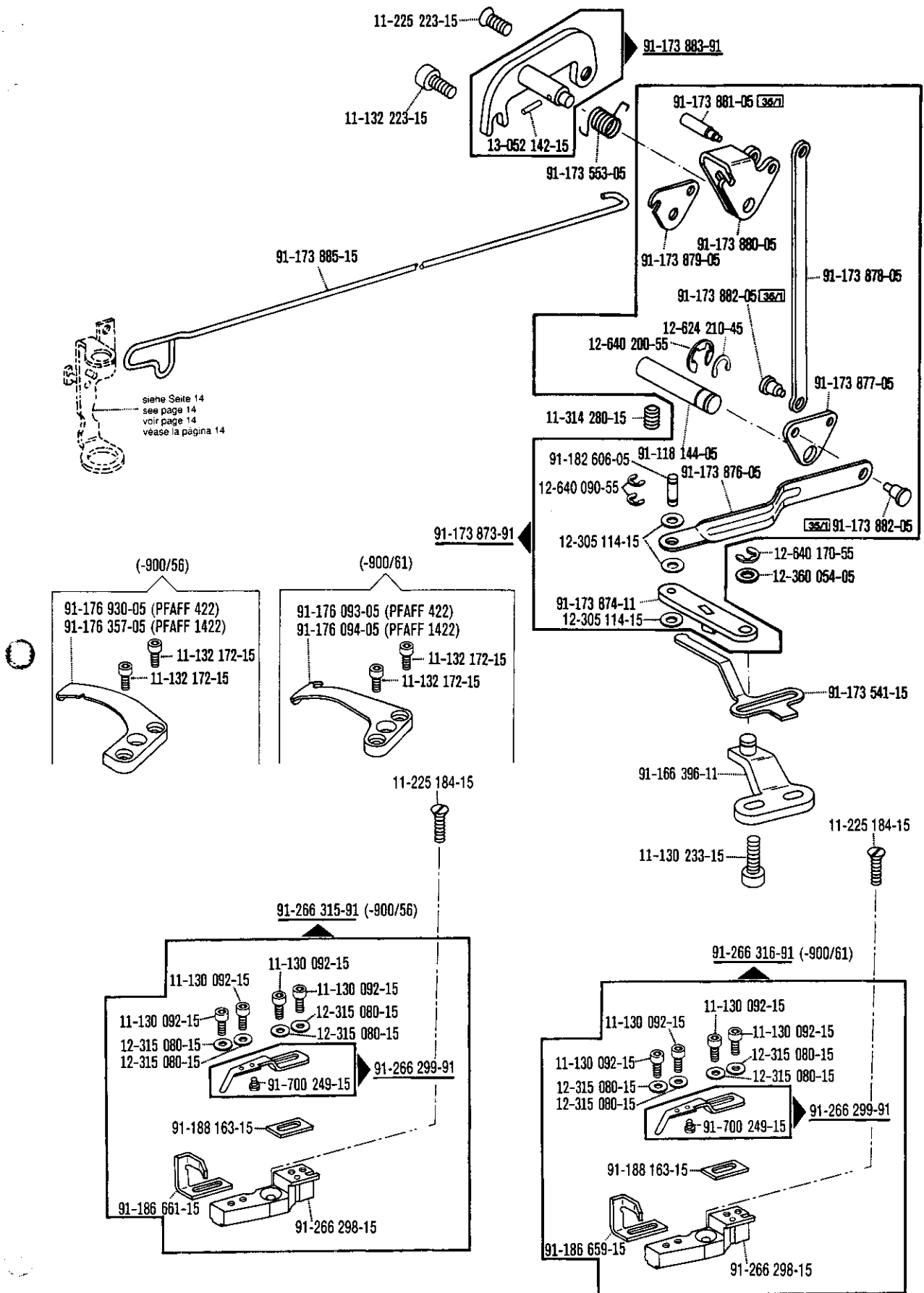

siehe Erläuterungen Register **A** - **357**
 see explanations in section **A** - **357**
 voir légende registre **A** - **357**
 ver explicaciones del registro **A** - **357**

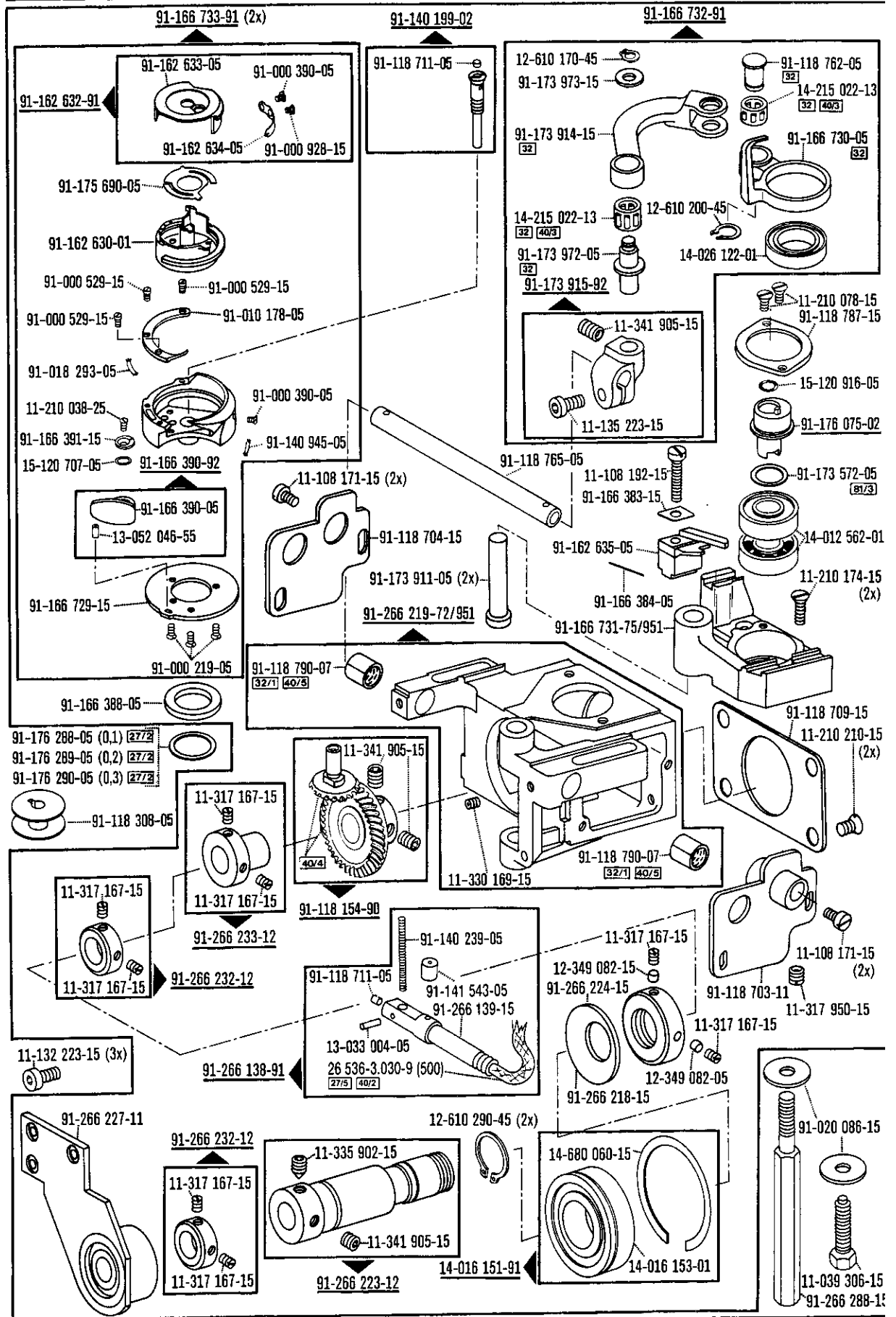

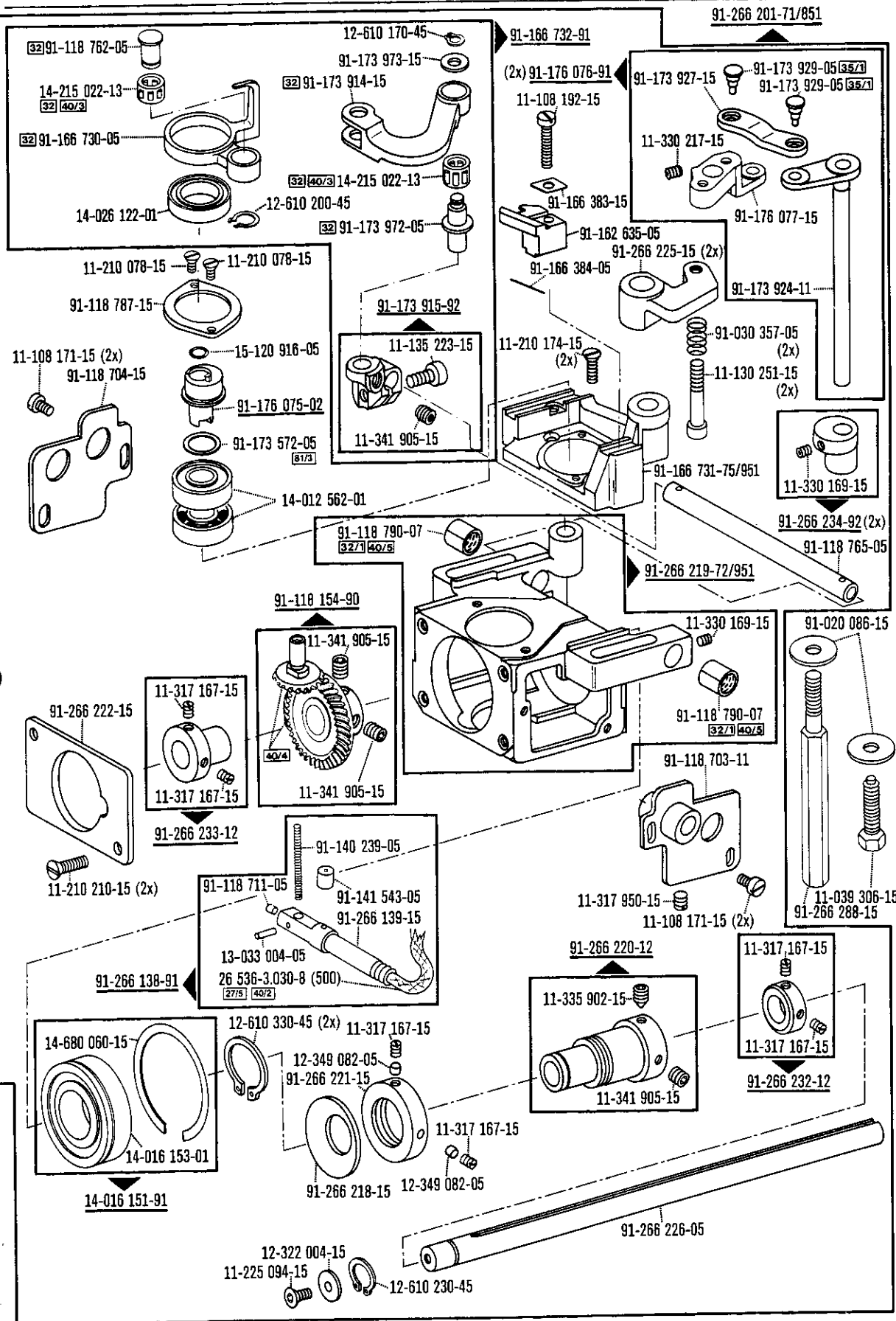

siehe Erläuterungen Register A B
 see explanations in section A B
 voir légende registre A B
 ver explicaciones del registro A B

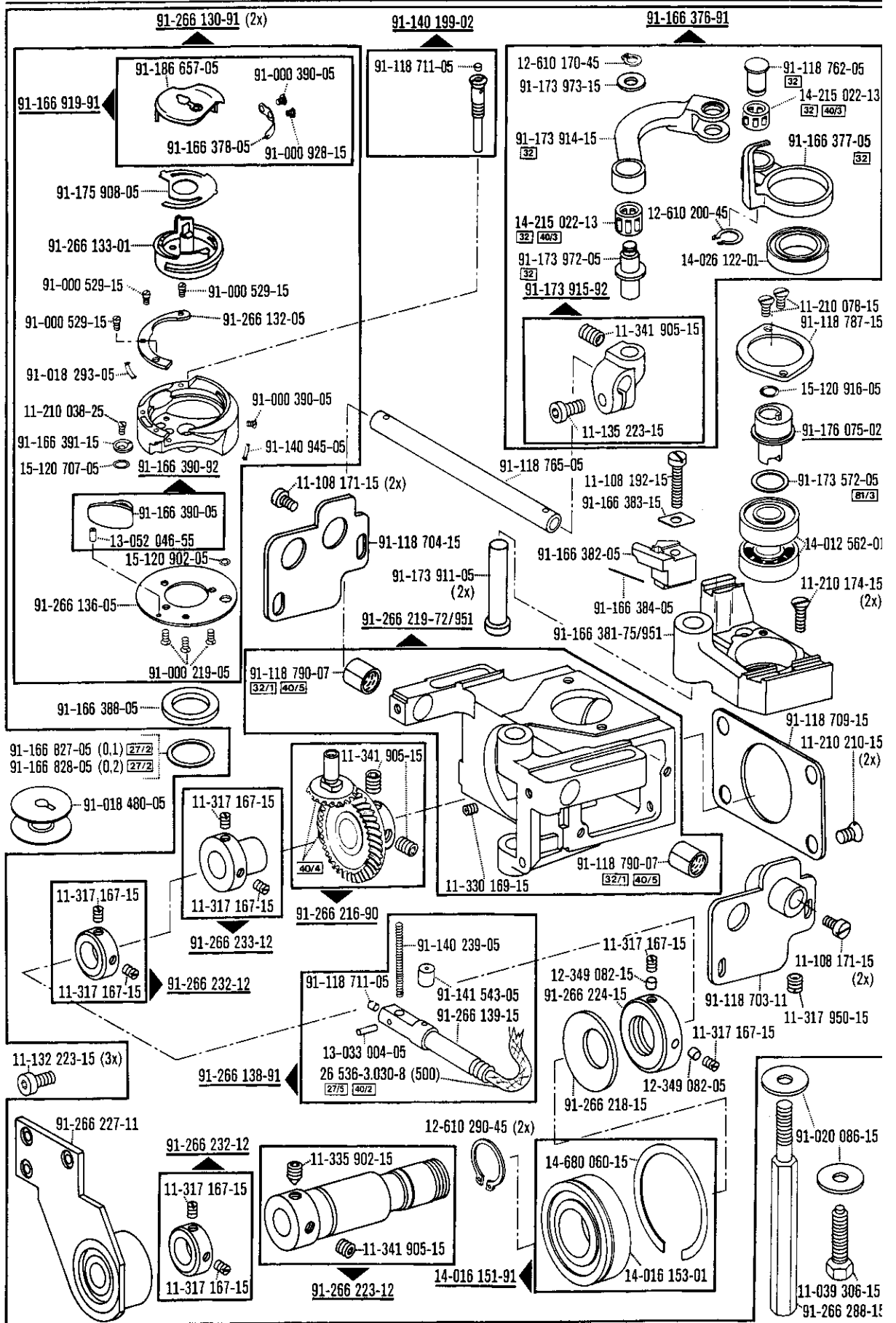

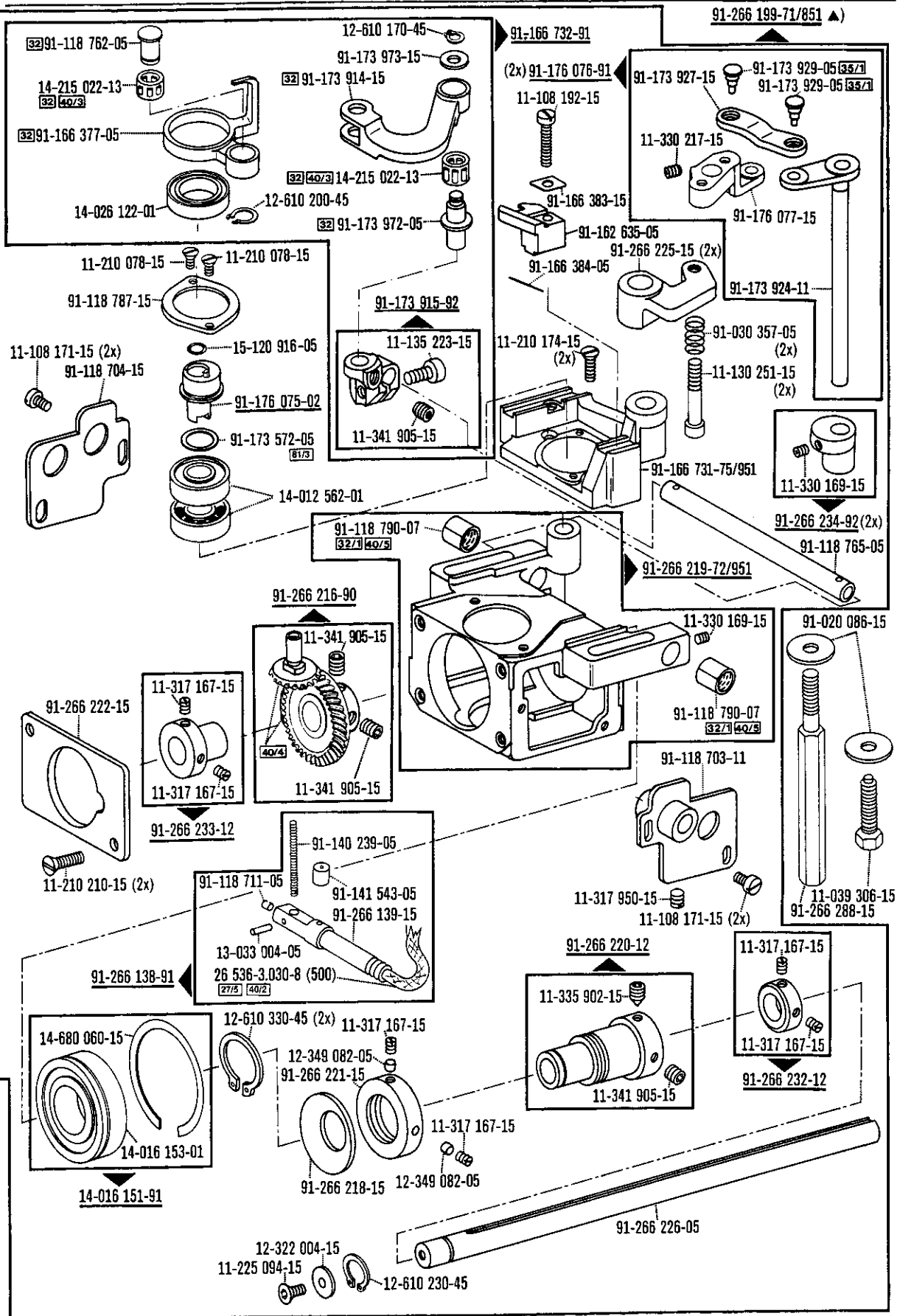

☐ siehe Erläuterungen Register [] []
see explanations in section [] []
voir légende registre [] []

▲ Bei Maschinen mit -720/.. bis 8 mm Nadelabstand
On machines equipped with -720/.. up to a needle gauge of 8 mm
Pour les machines avec -720/.. jusqu'à 8 mm d'écartement des aiguilles

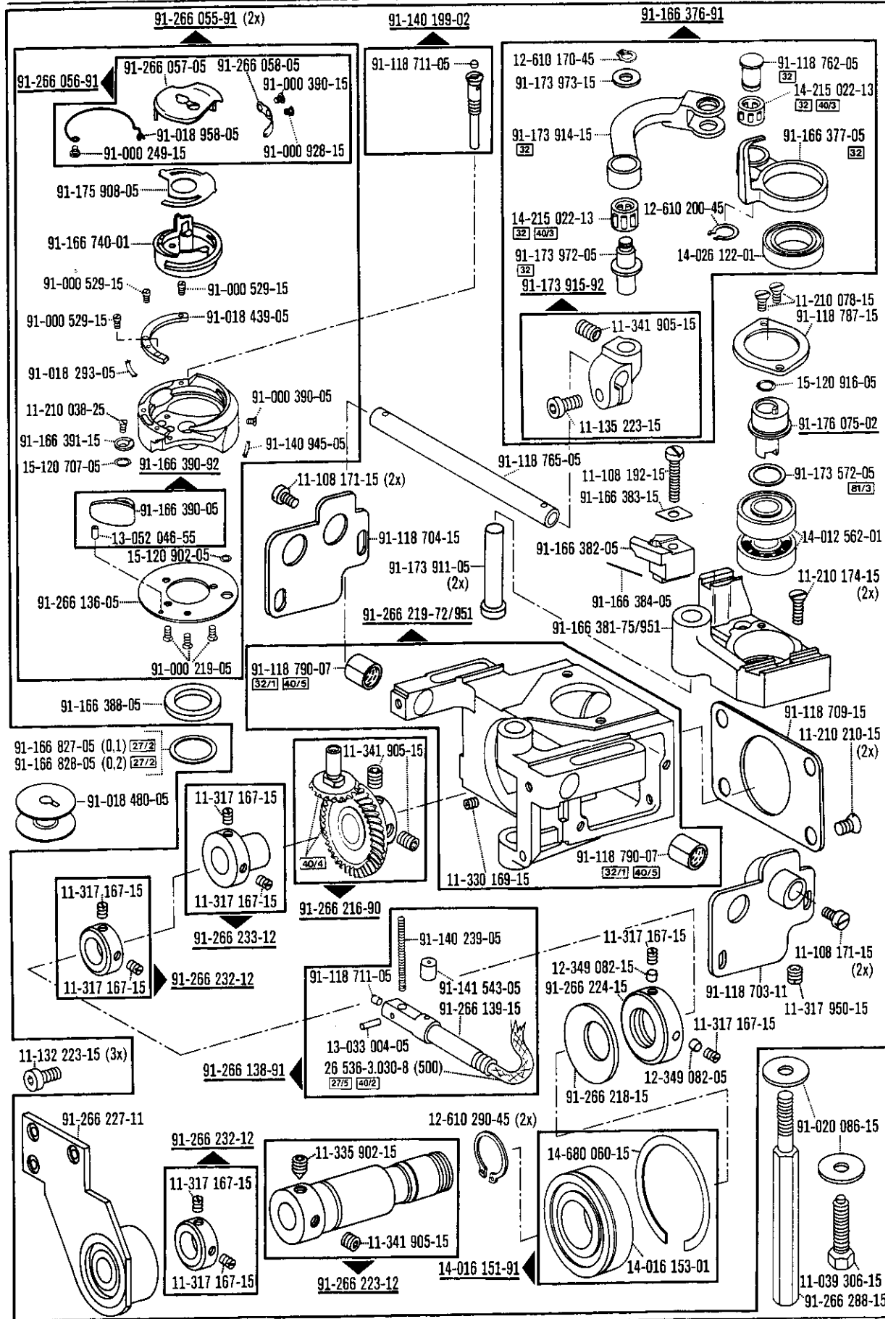

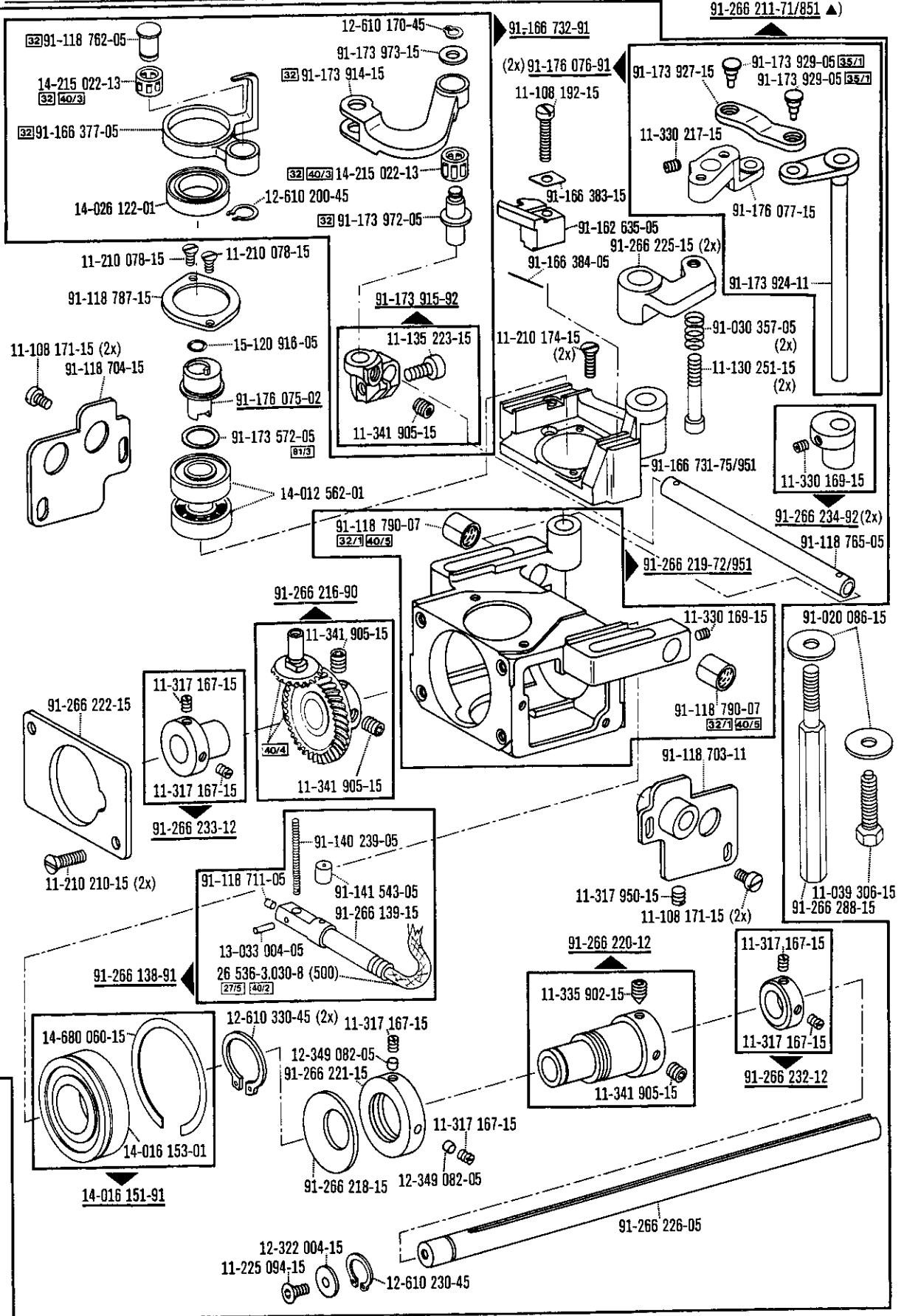

☐ siehe Erläuterungen Register
see explanations in section
voir légende registre

▲ Ab 8 mm Nadelabstand
From a needle gauge of 8 mm onwards
A partir d'un écartement des aiguilles de 8 mm

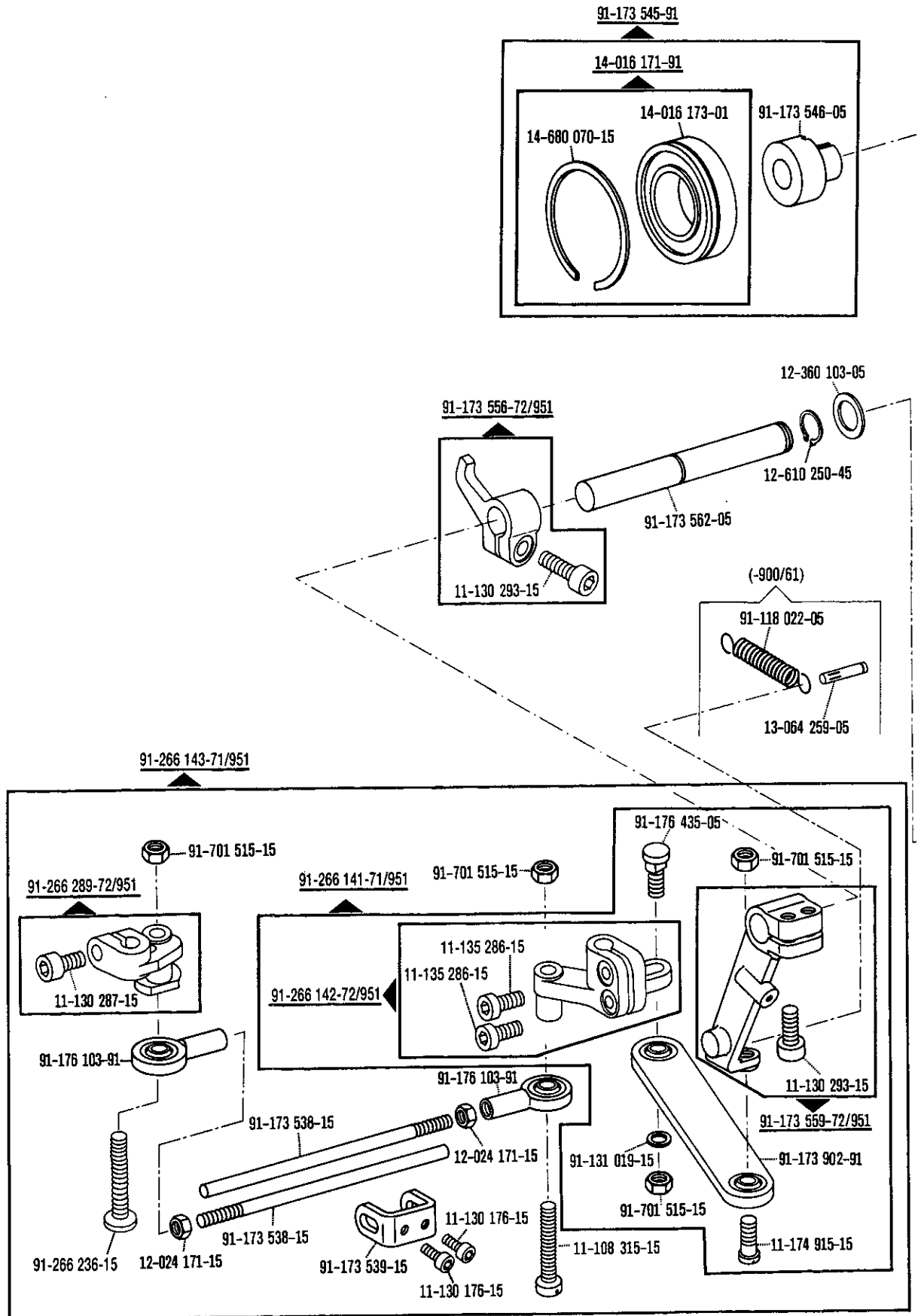

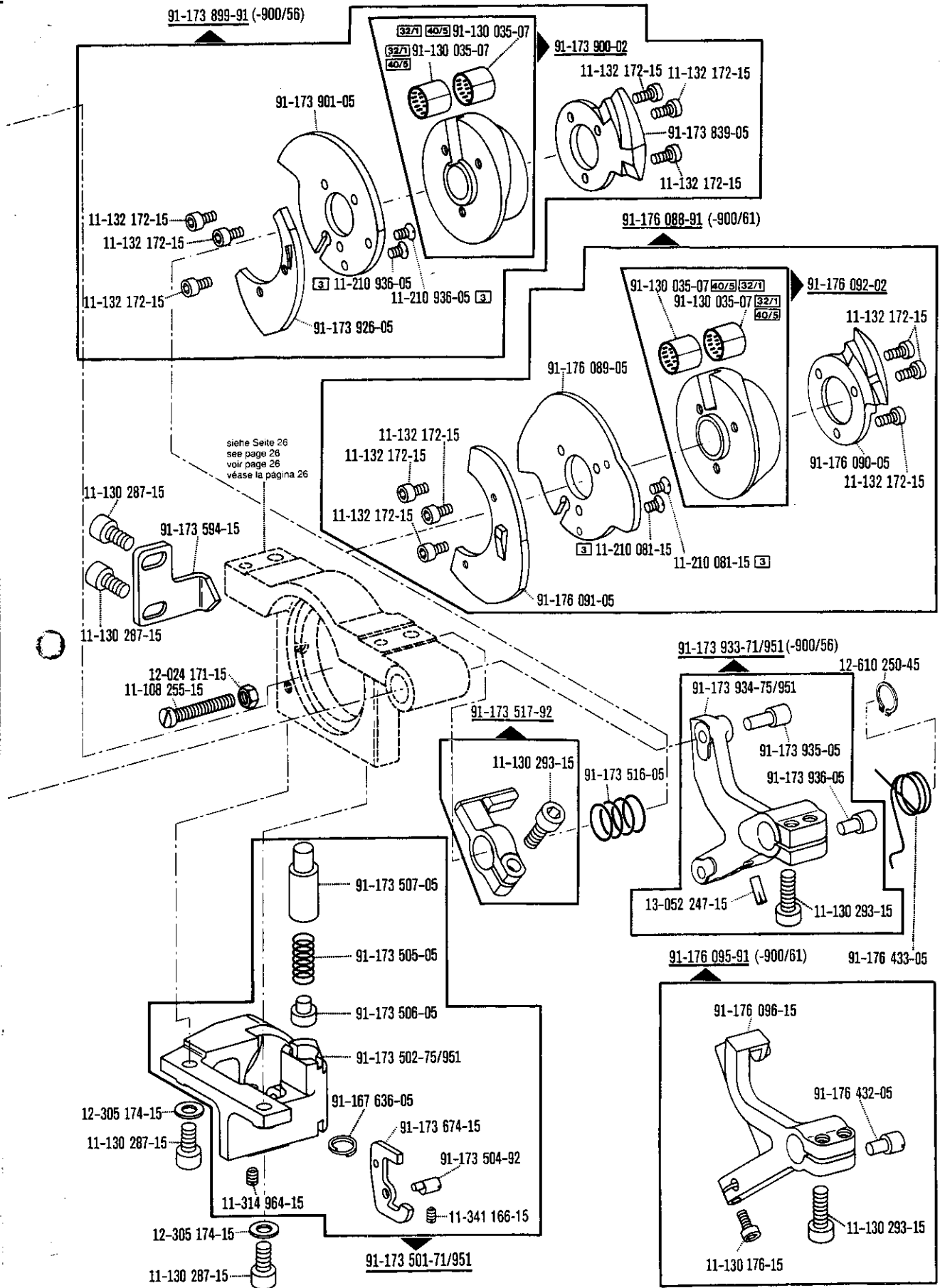

□ siehe Erläuterungen Register see explanations in section voir légende registre ver explicaciones del registro

91-090 823-91 [90/38]

91-290 001-91 [90/39]

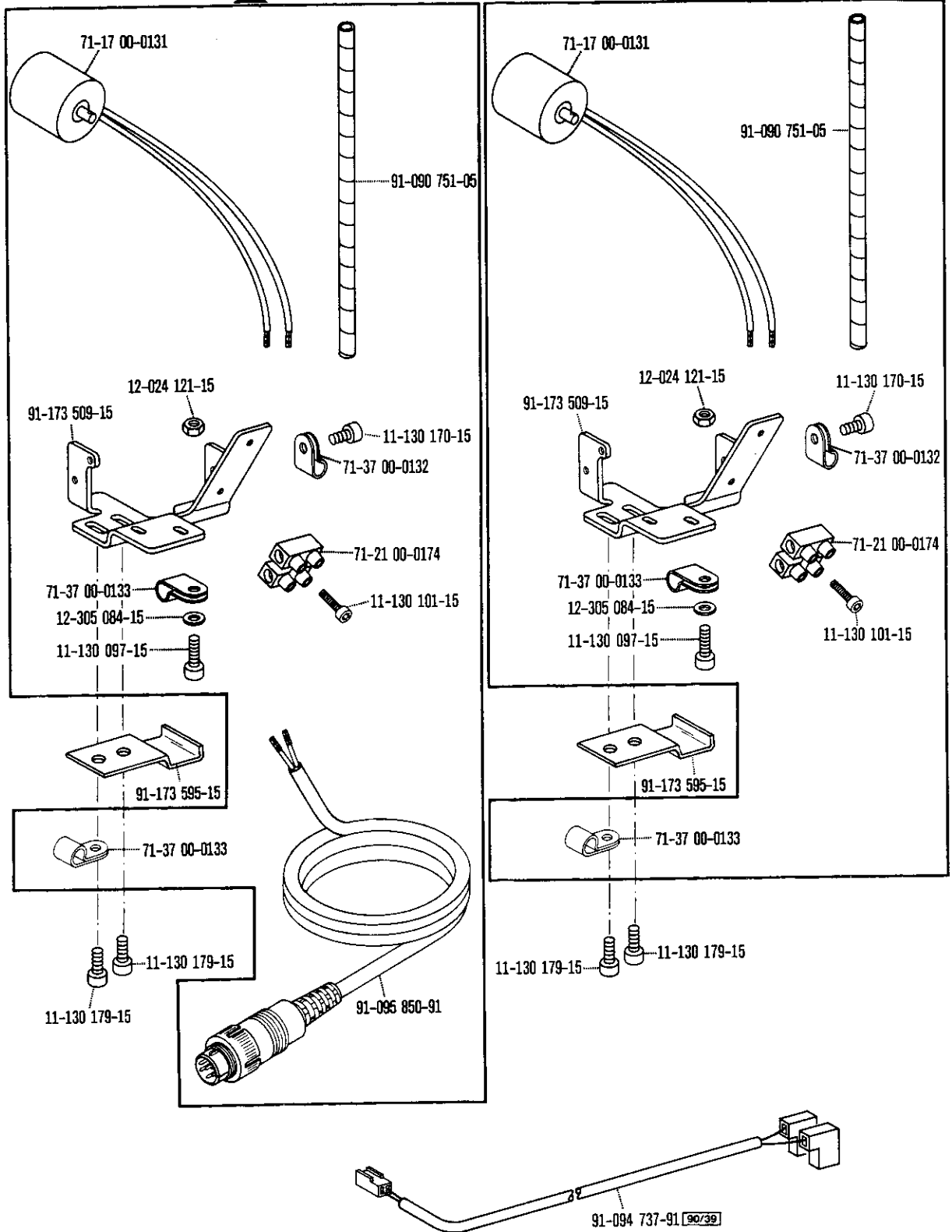

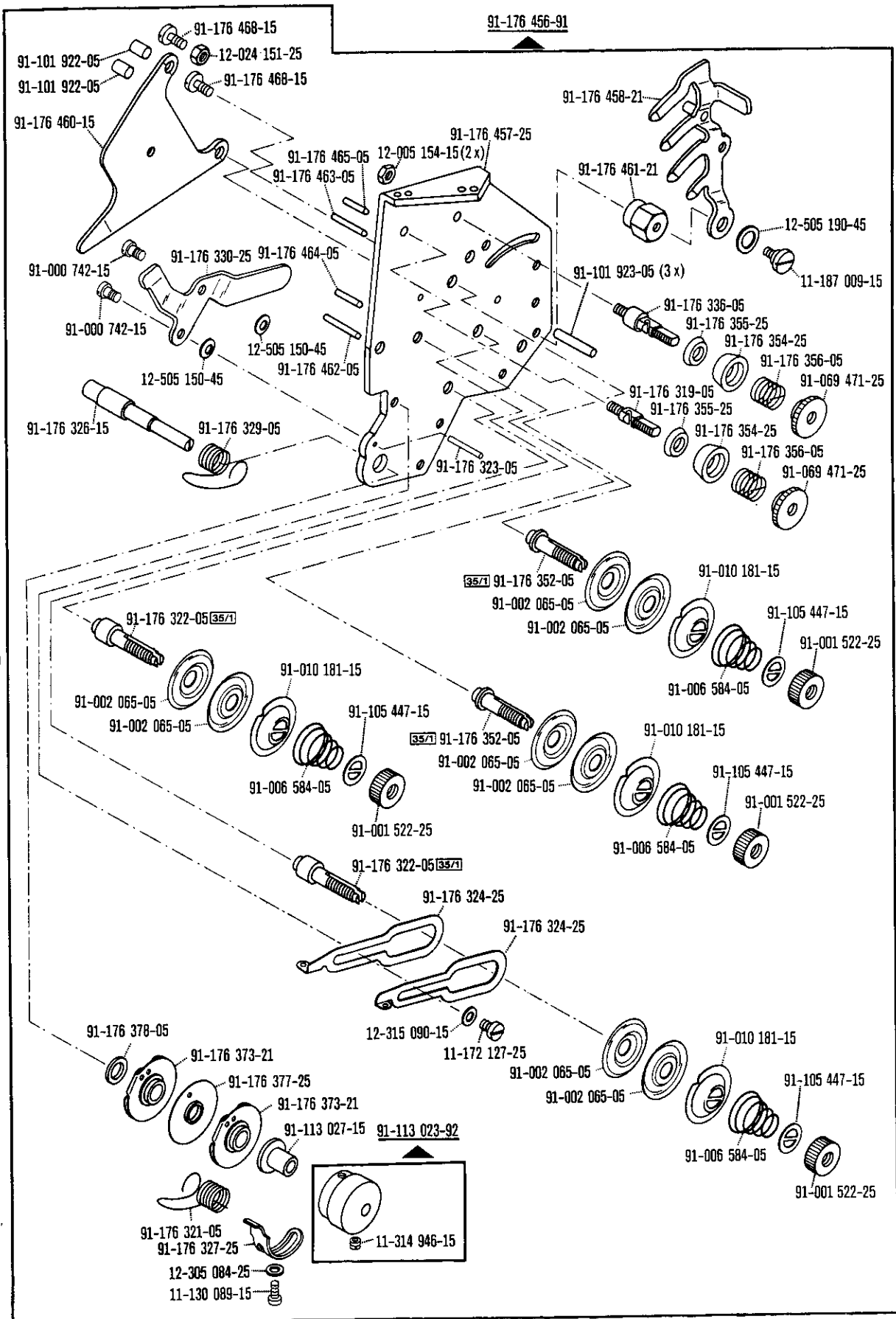

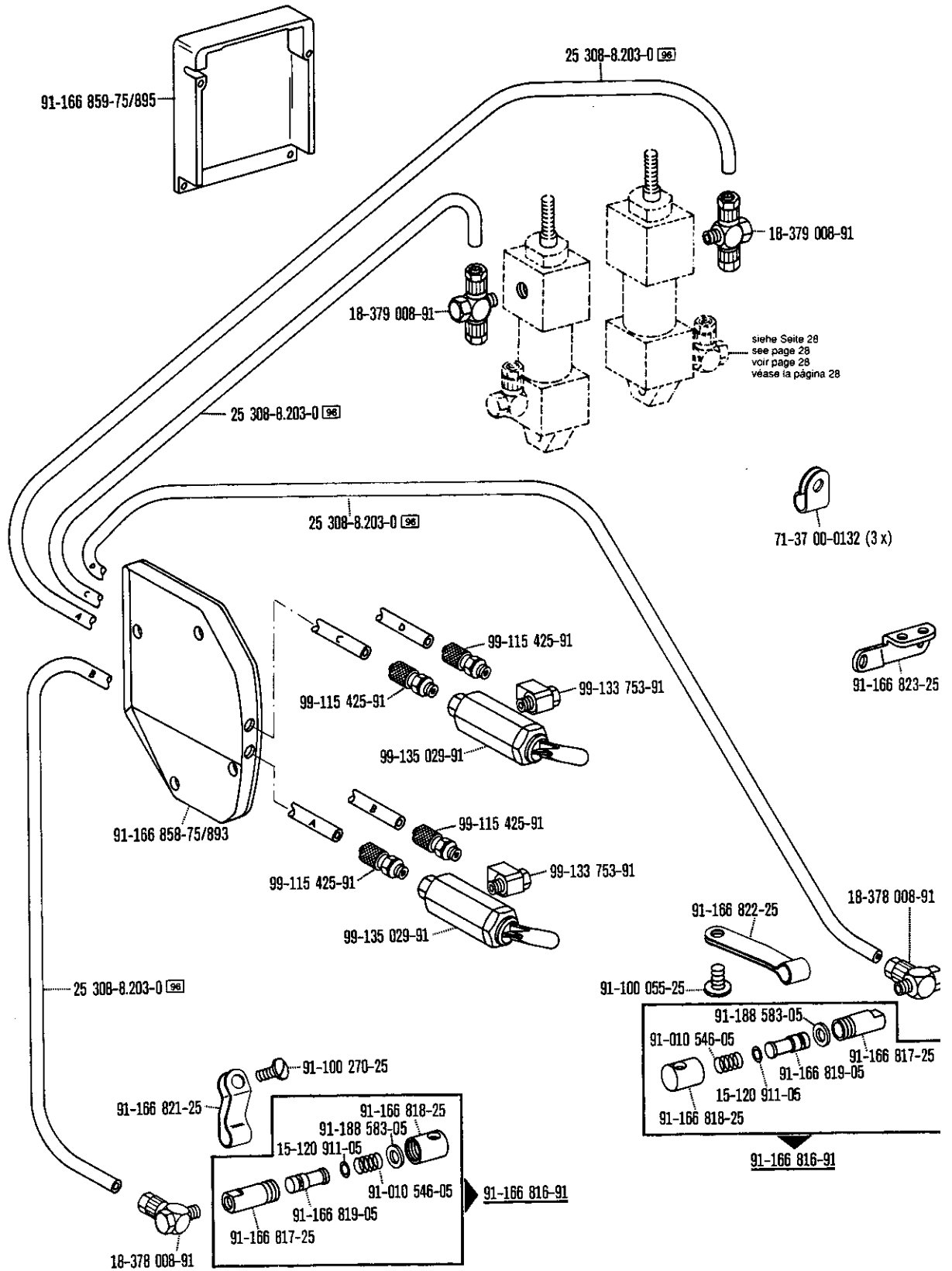

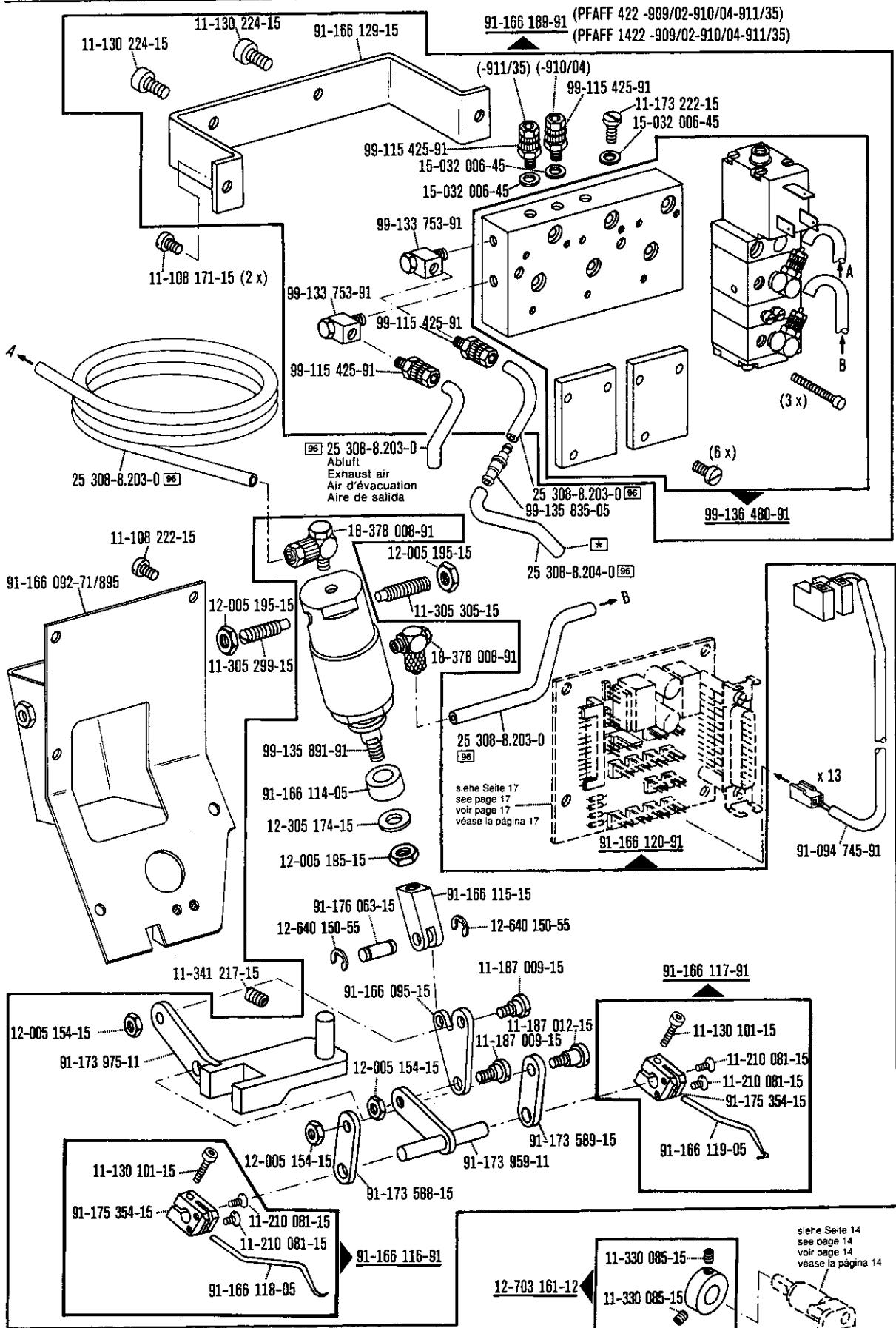

-909/..

☐ siehe Erläuterungen Register
see explanations in section
voir légende registre

☐ Zur Wartungseinheit
For conditioning unit
Pour la conditionneur d'air comprimé

(PFAFF 422 -720/04-909/02-910/15-911/35)
(PFAFF 422 -720/04-909/02-910/15-911/35-918/26)
(PFAFF 1422 -720/04-909/02-910/15-911/35)
(PFAFF 1422 -720/04-909/02-910/15-911/35-918/26)

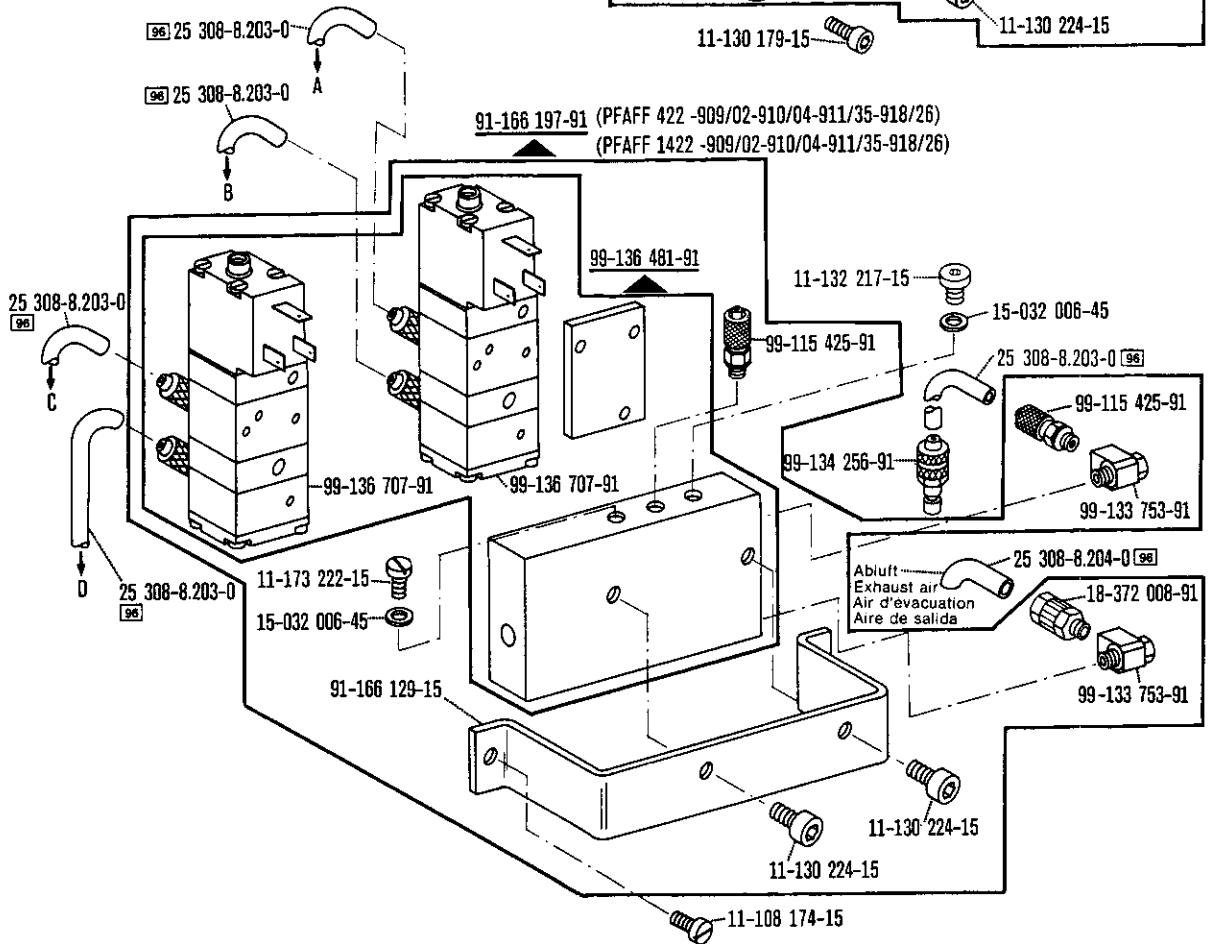
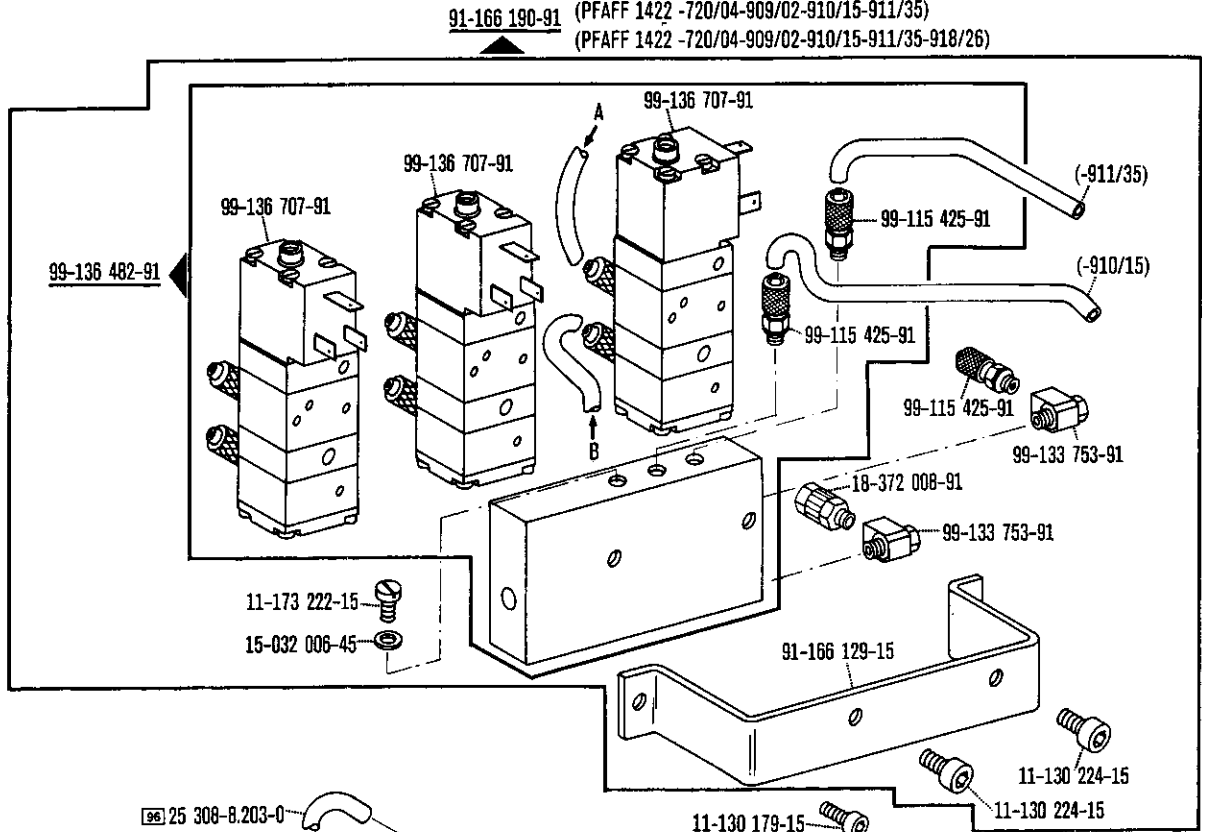

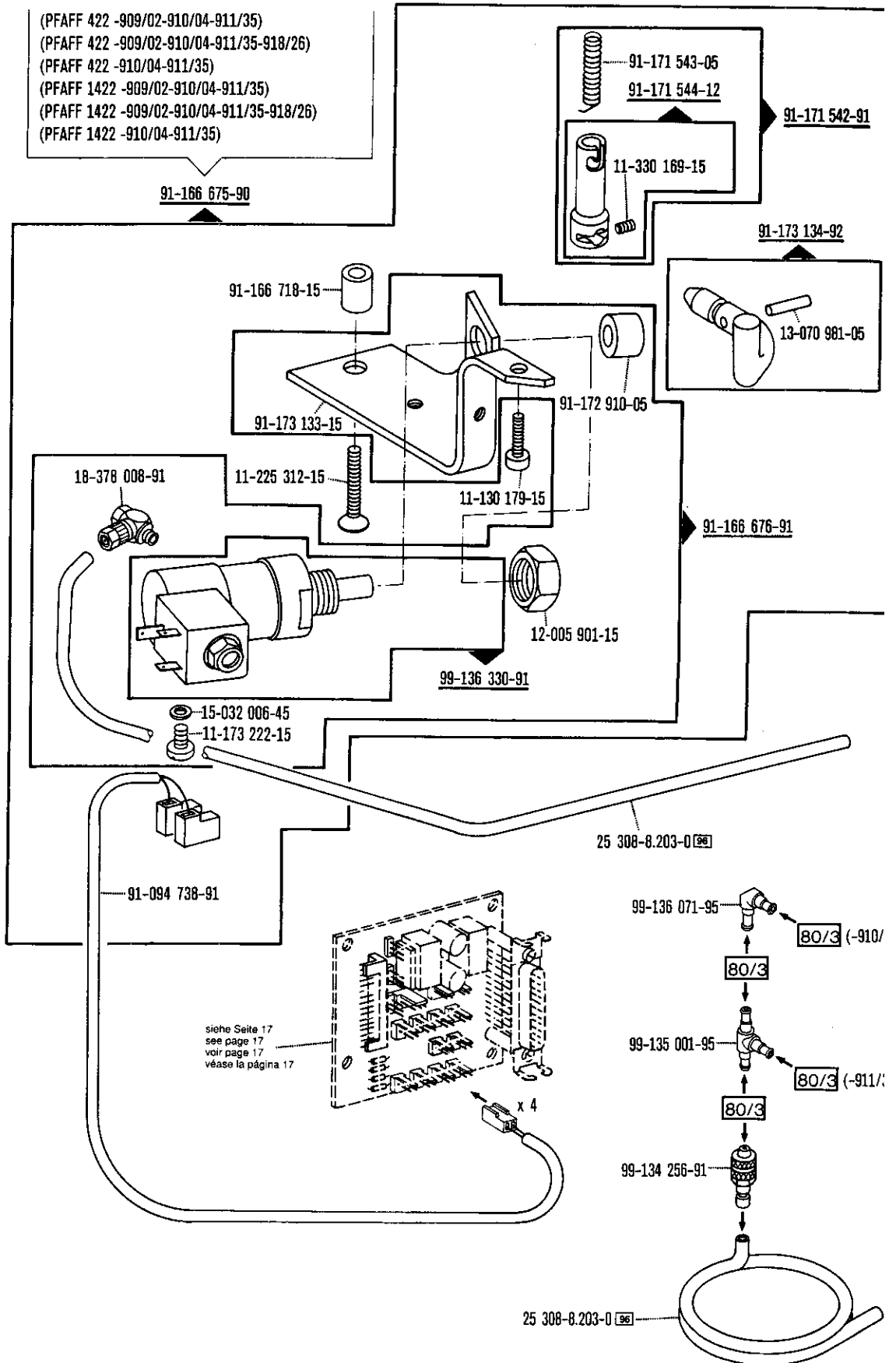

Relève-pied automatique
Alzaprensatelas

-910/15 zur - pour
 for - para

PFAFF 422-720/04
PFAFF 1422-720/04

Conditionneur d'air comprimé -925/02 nécessaire
 Requiere grupo acondicionador del aire comprimido -925/02

(PFAFF 422 -720/04-909/02-910/15-911/35)
 (PFAFF 422 -720/04-909/02-910/15-911/35-918/26)
 (PFAFF 422 -720/04-910/15-911/35)
 (PFAFF 1422 -720/04-909/02-910/15-911/35)
 (PFAFF 1422 -720/04-909/02-910/15-911/35-918/26)
 (PFAFF 1422 -720/04-910/15-911/35)

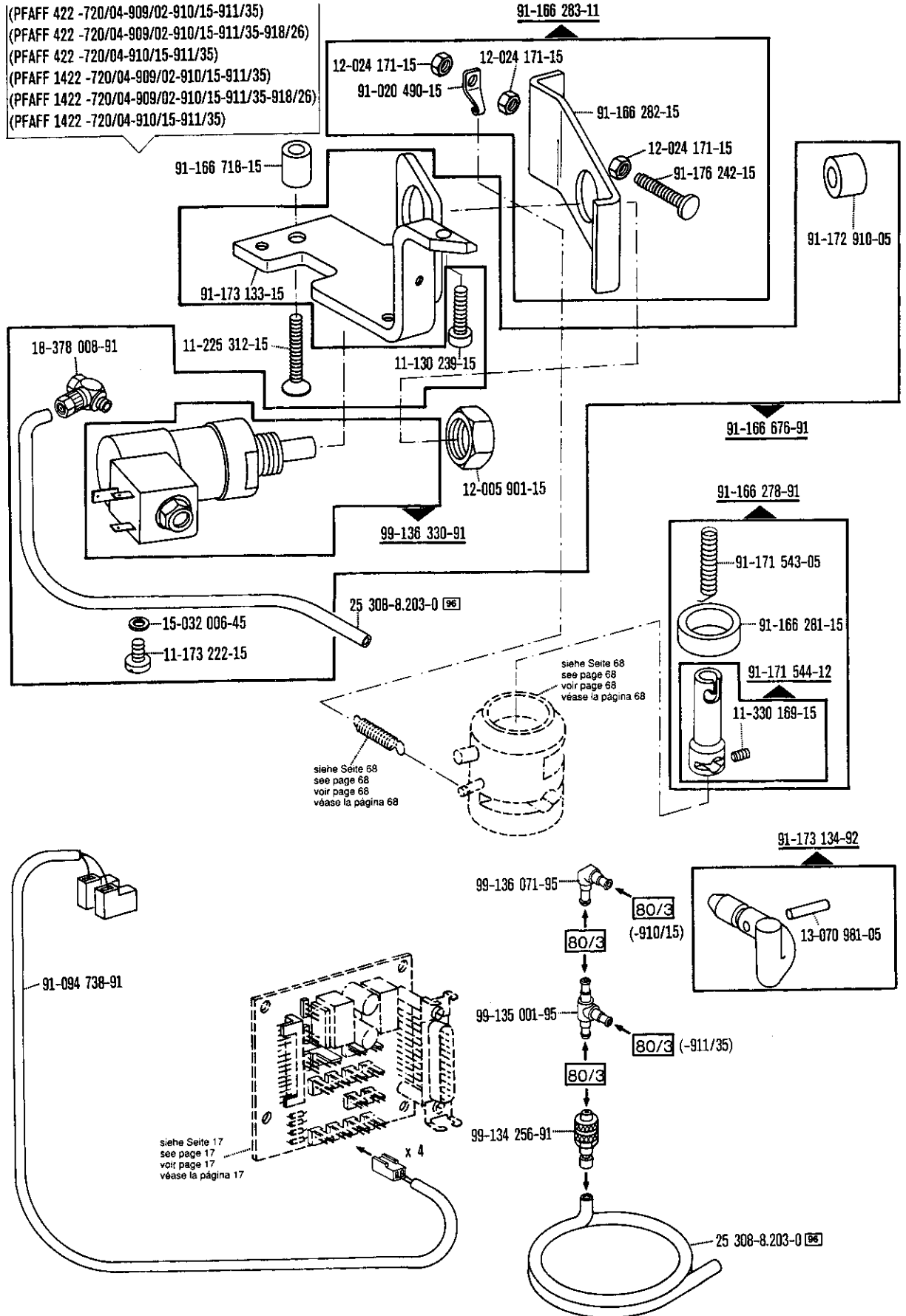

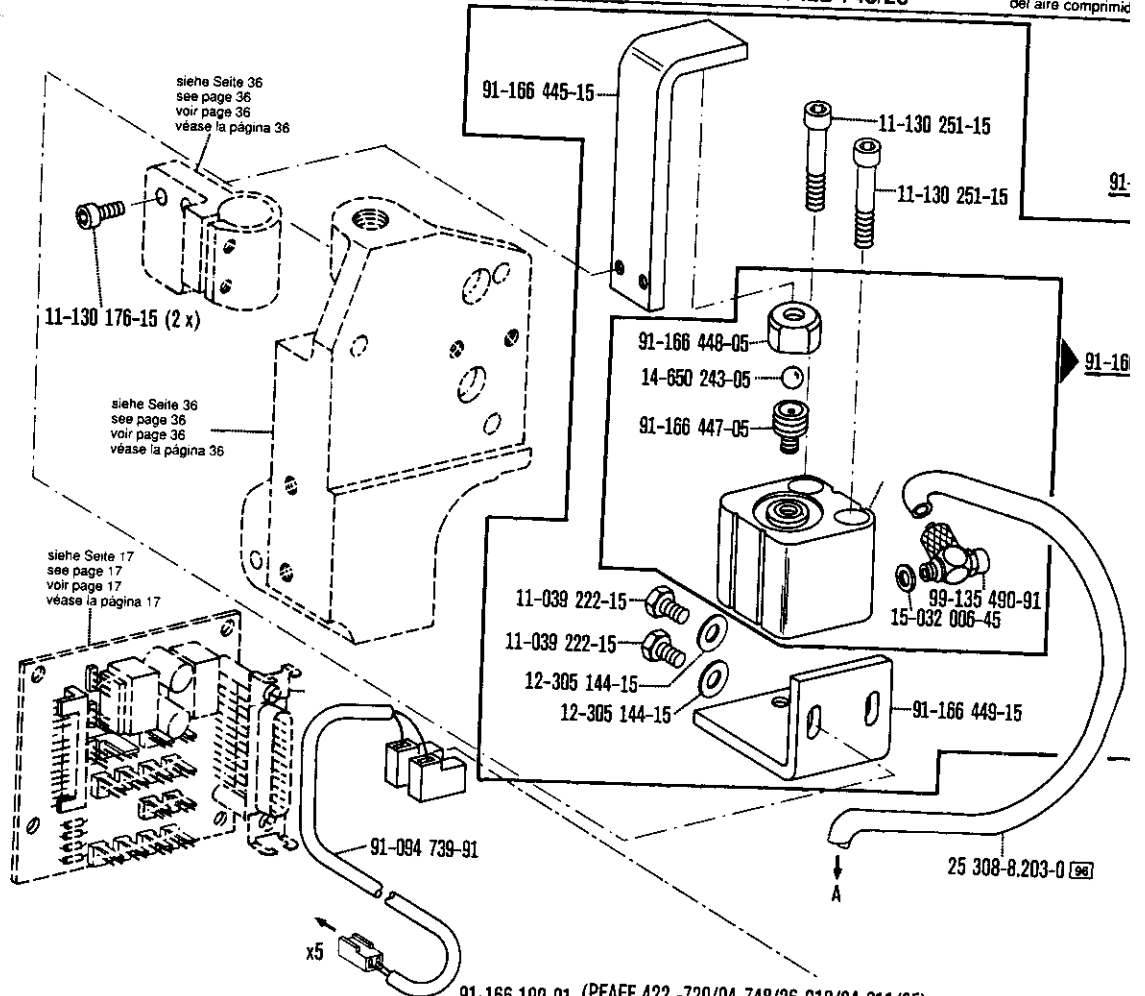

91-166 190-91 (PFAFF 422 -720/04-748/26-910/24-911/35)
(PFAFF 1422 -720/04-748/26-910/24-911/35)

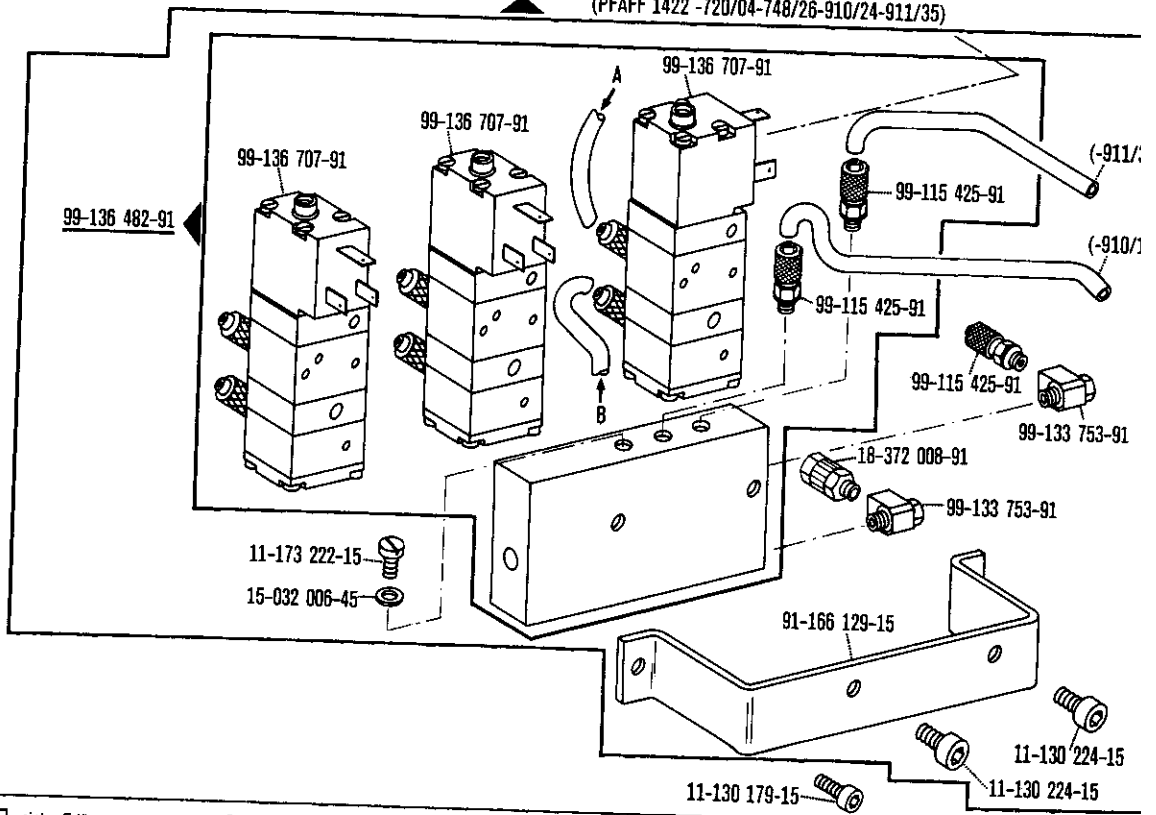

☐ siehe Erläuterungen Register A-B
see explanations in section A-B
voir légende registre A-B
ver explicaciones del registro A-B

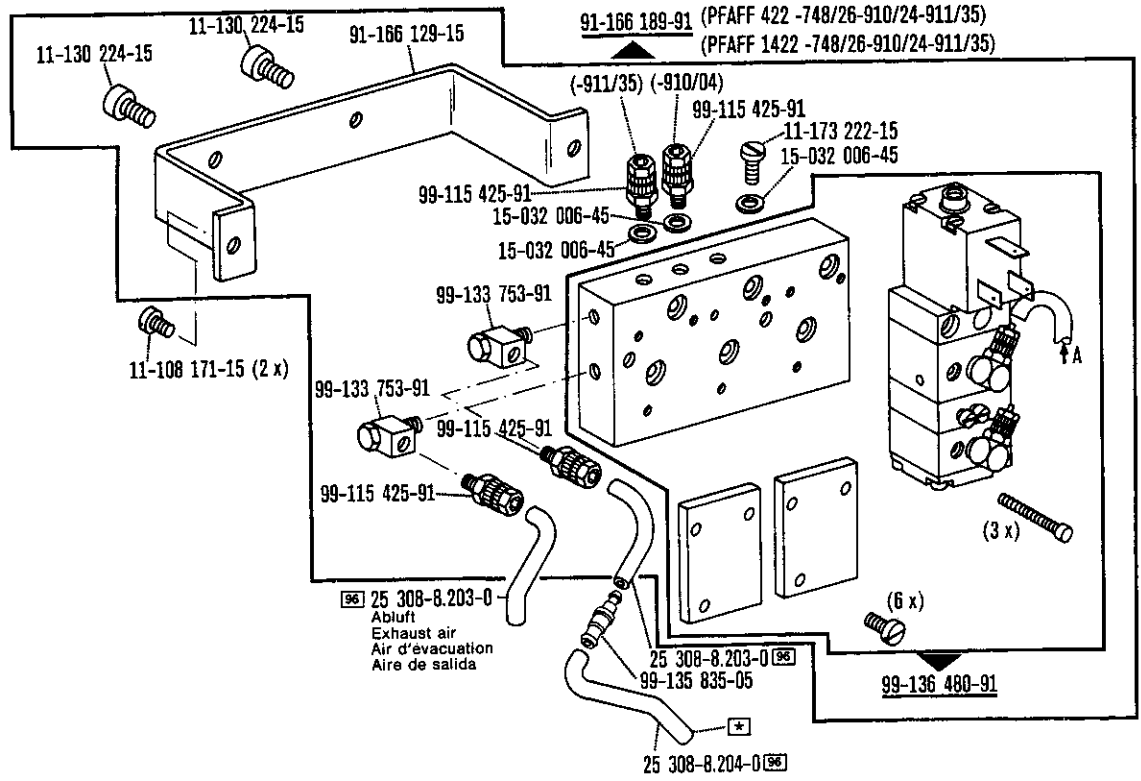

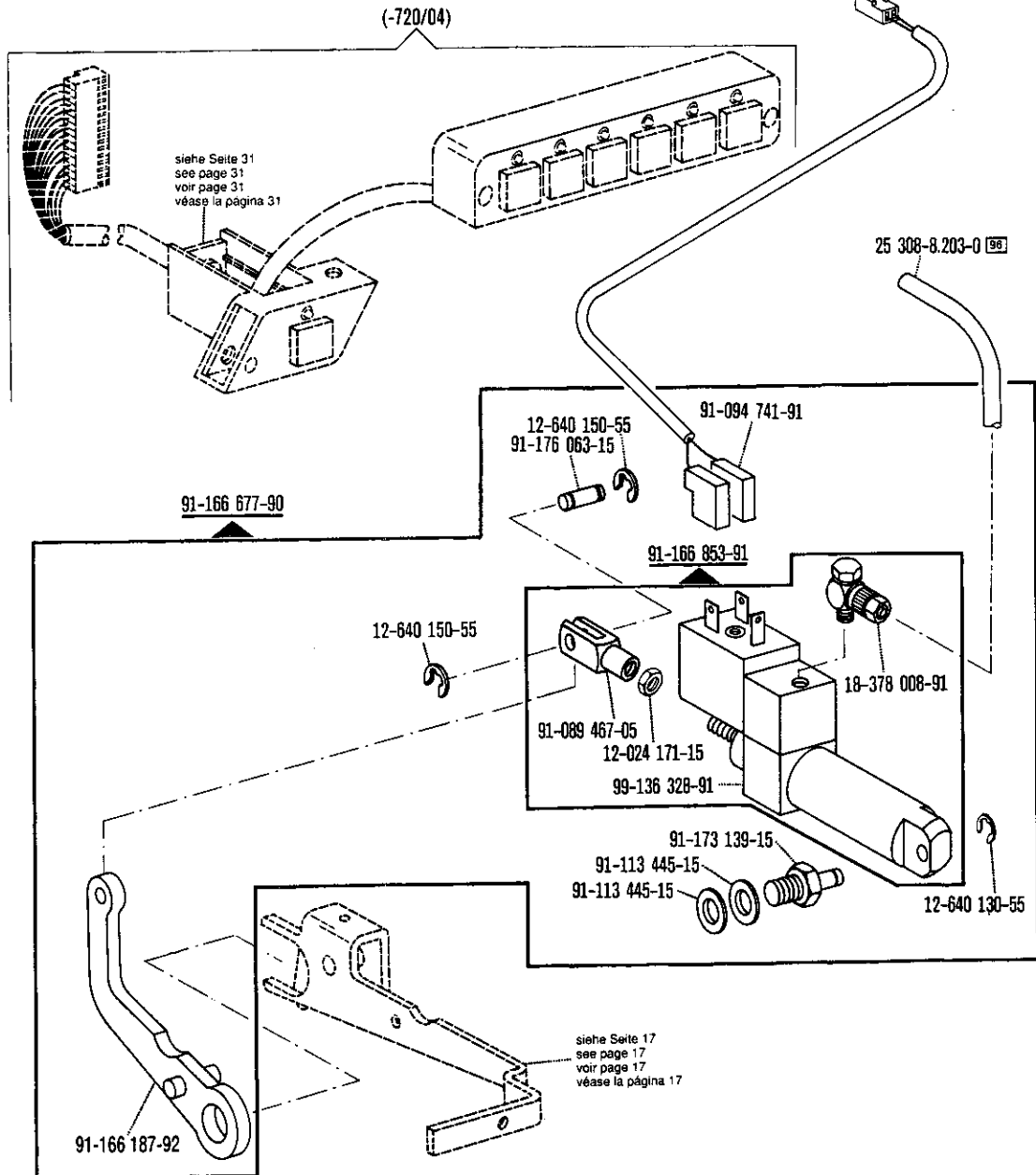
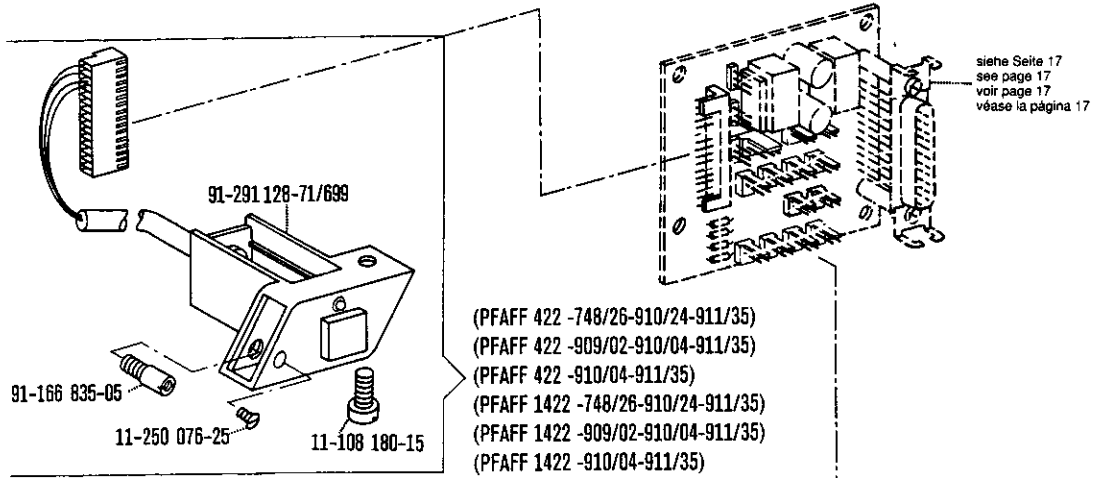

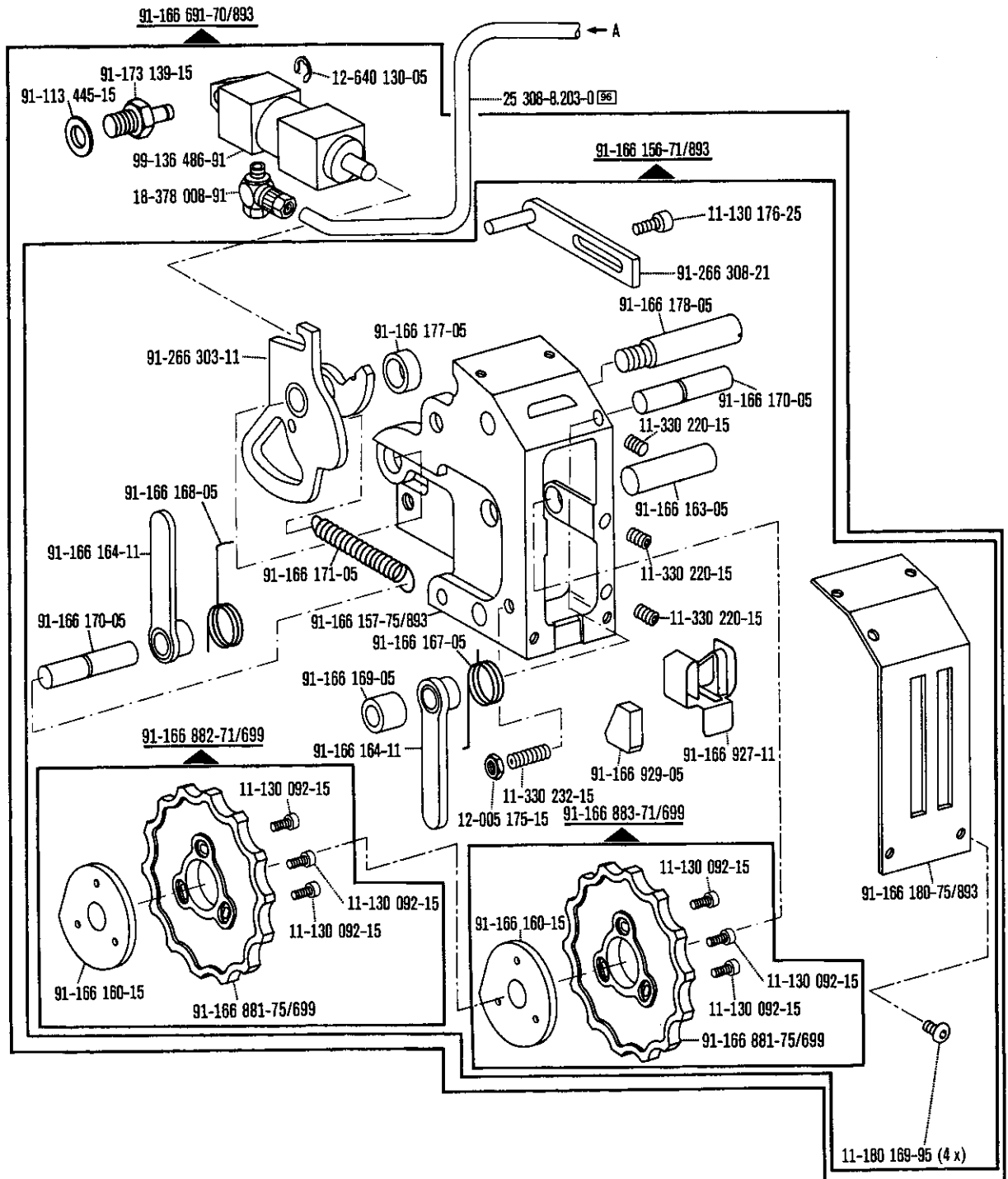

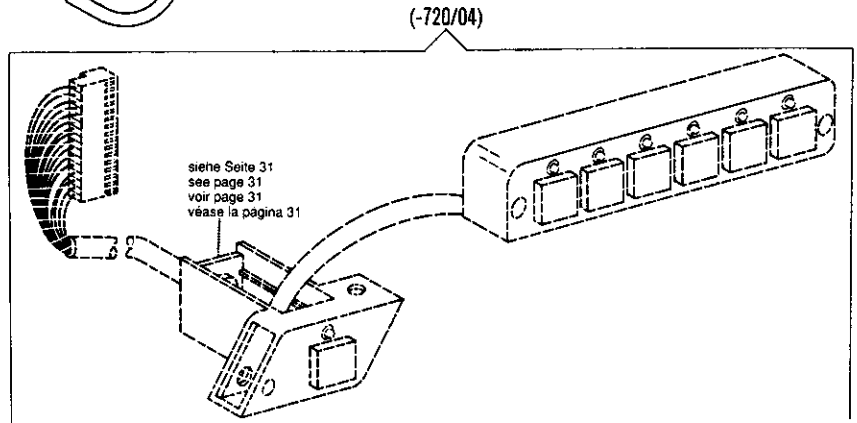
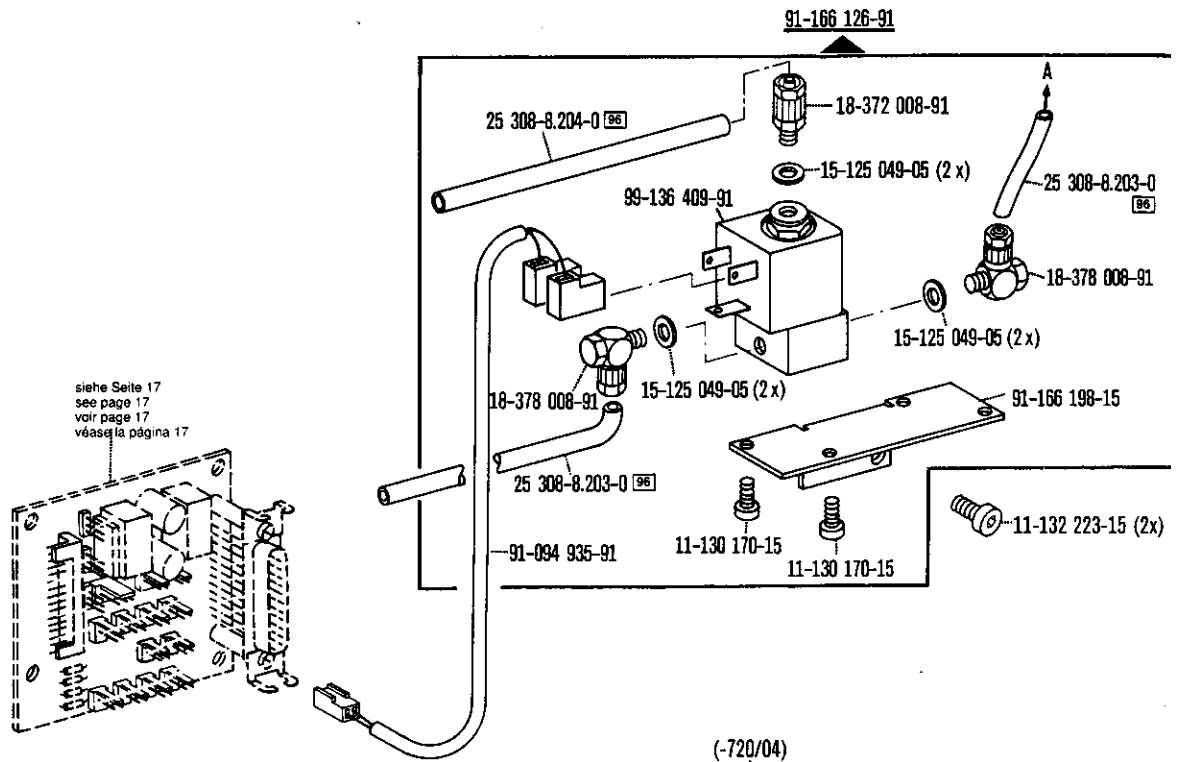

(PFAFF 422 -909/02-910/04-911/35-918/26)
 (PFAFF 1422 -909/02-910/04-911/35-918/26)

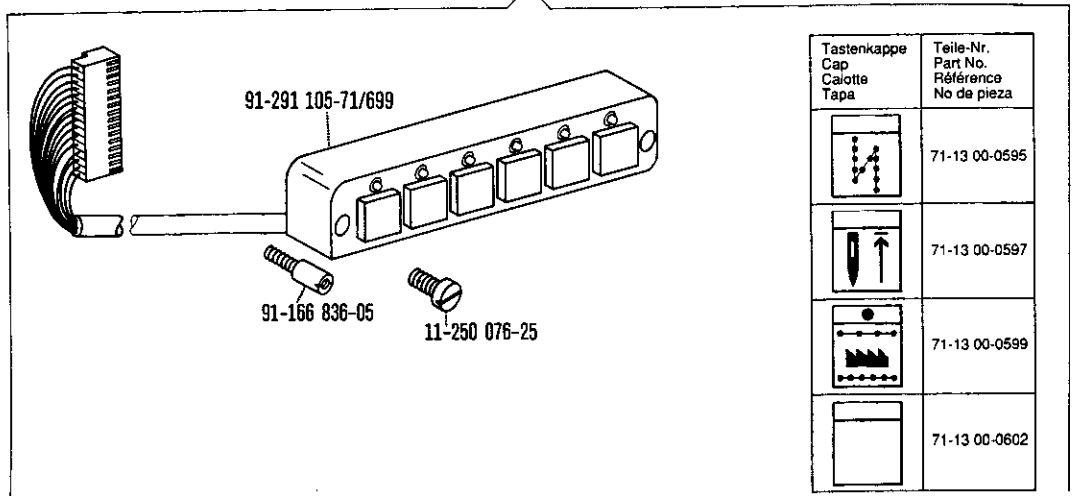

Tastenkappe Cap Caiotte Tapa	Teile-Nr. Part No. Référence No de pieza
	71-13 00-0595
	71-13 00-0597
	71-13 00-0599
	71-13 00-0602

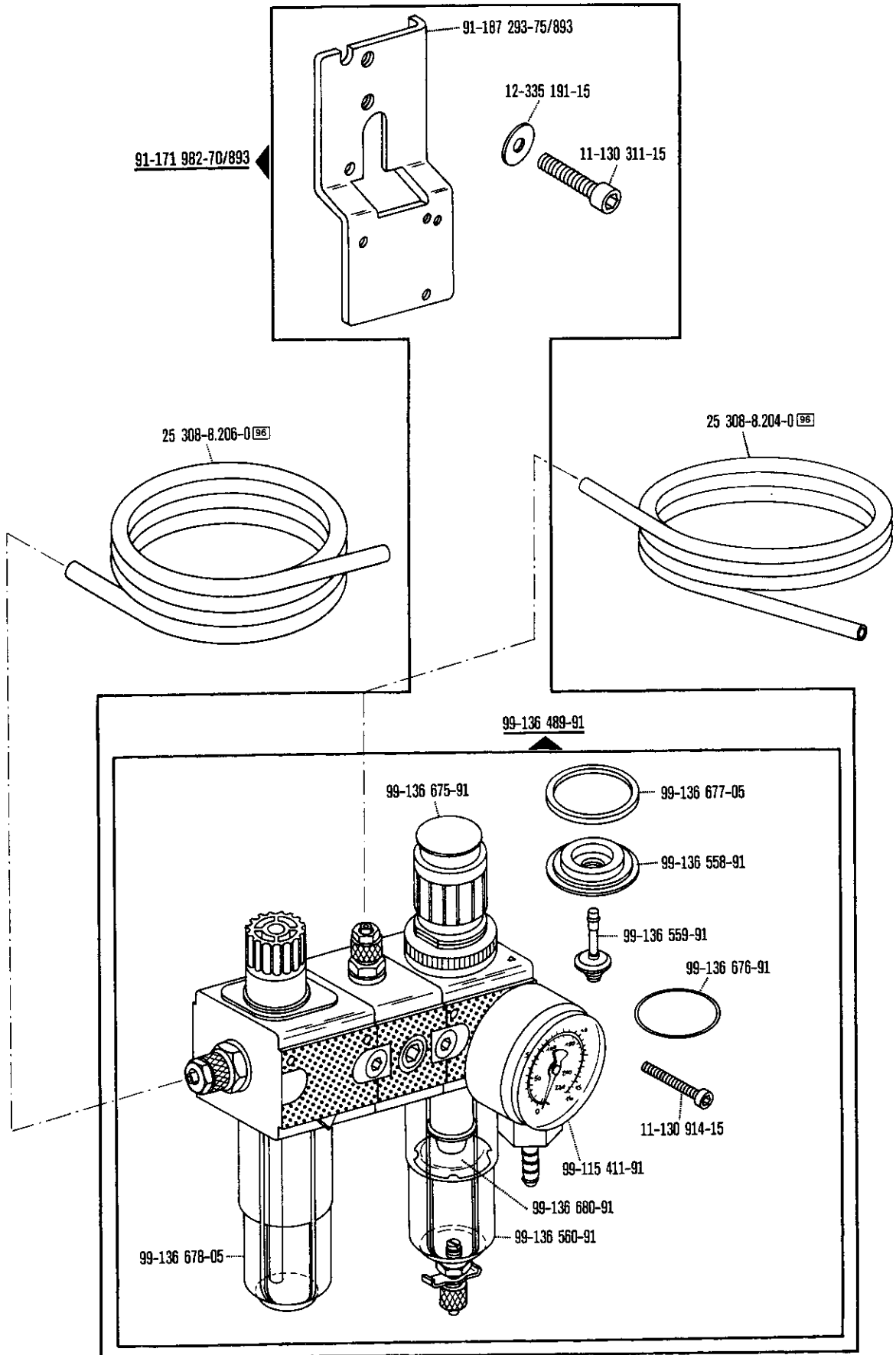

Contrôleur de canette
Detector del hilo de la canilla

-926/06 zur - pour
for - para PFAFF 1422; 1422-720/04

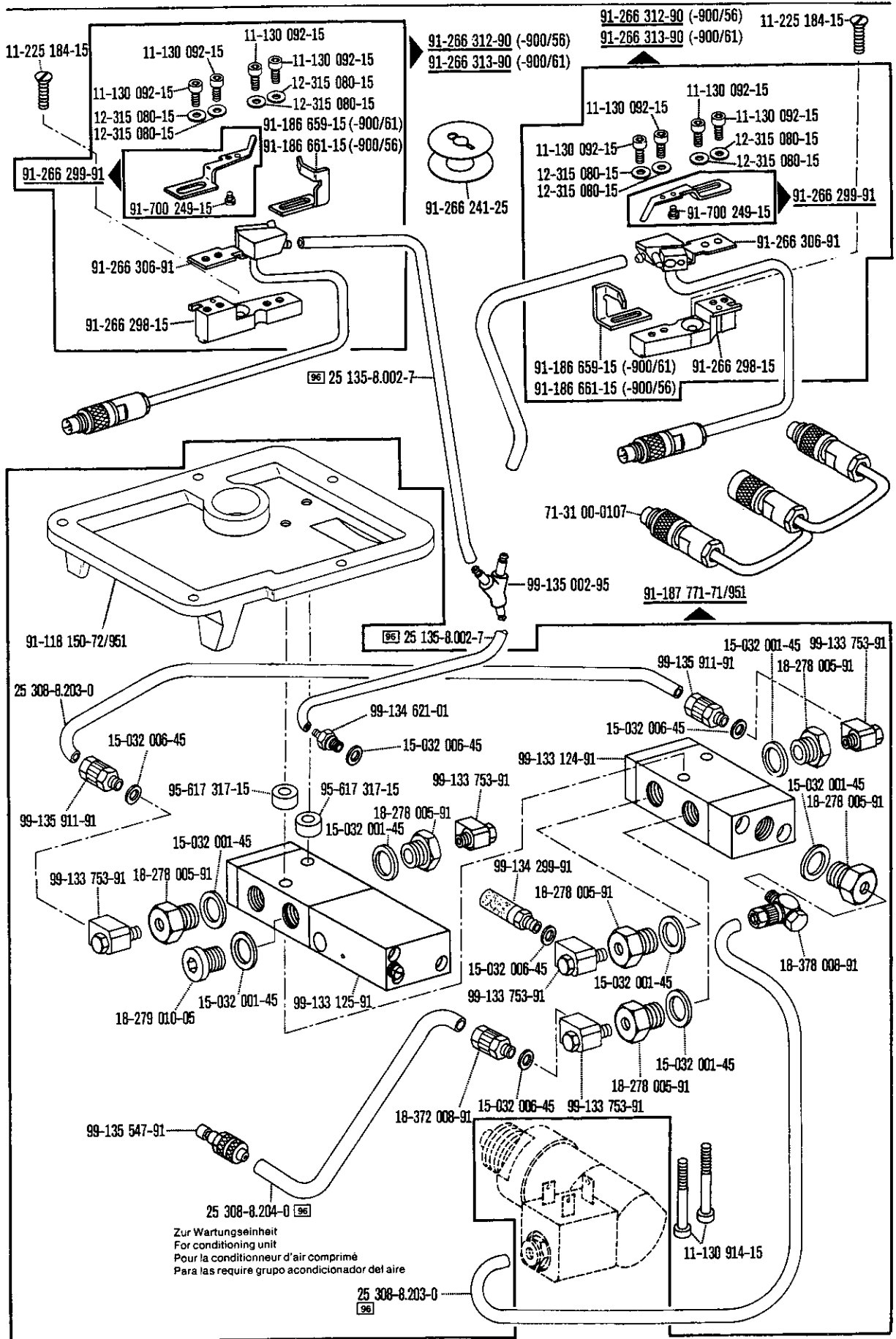

Zur Wartungseinheit
For conditioning unit
Pour la conditionneur d'air comprimé
Para las require grupo acondicionador del aire

☐ siehe Erläuterungen Register A1-10
see explanations in section A1-10

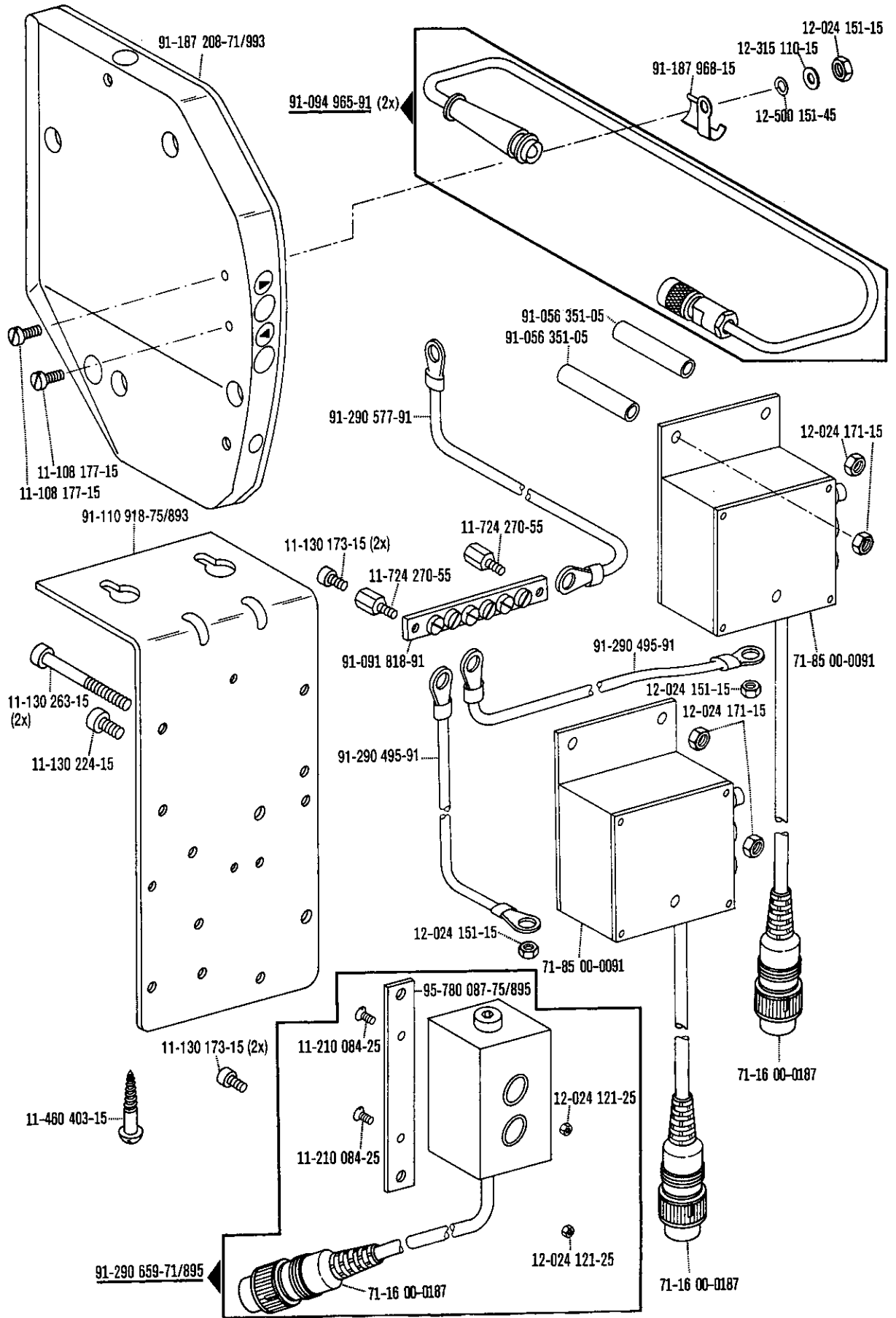

Accessory parts
Accessoires
Accesorios

zur - pour
for - para

PFAFF 422; 422-720/04
PFAFF 1422; 1422-720/04

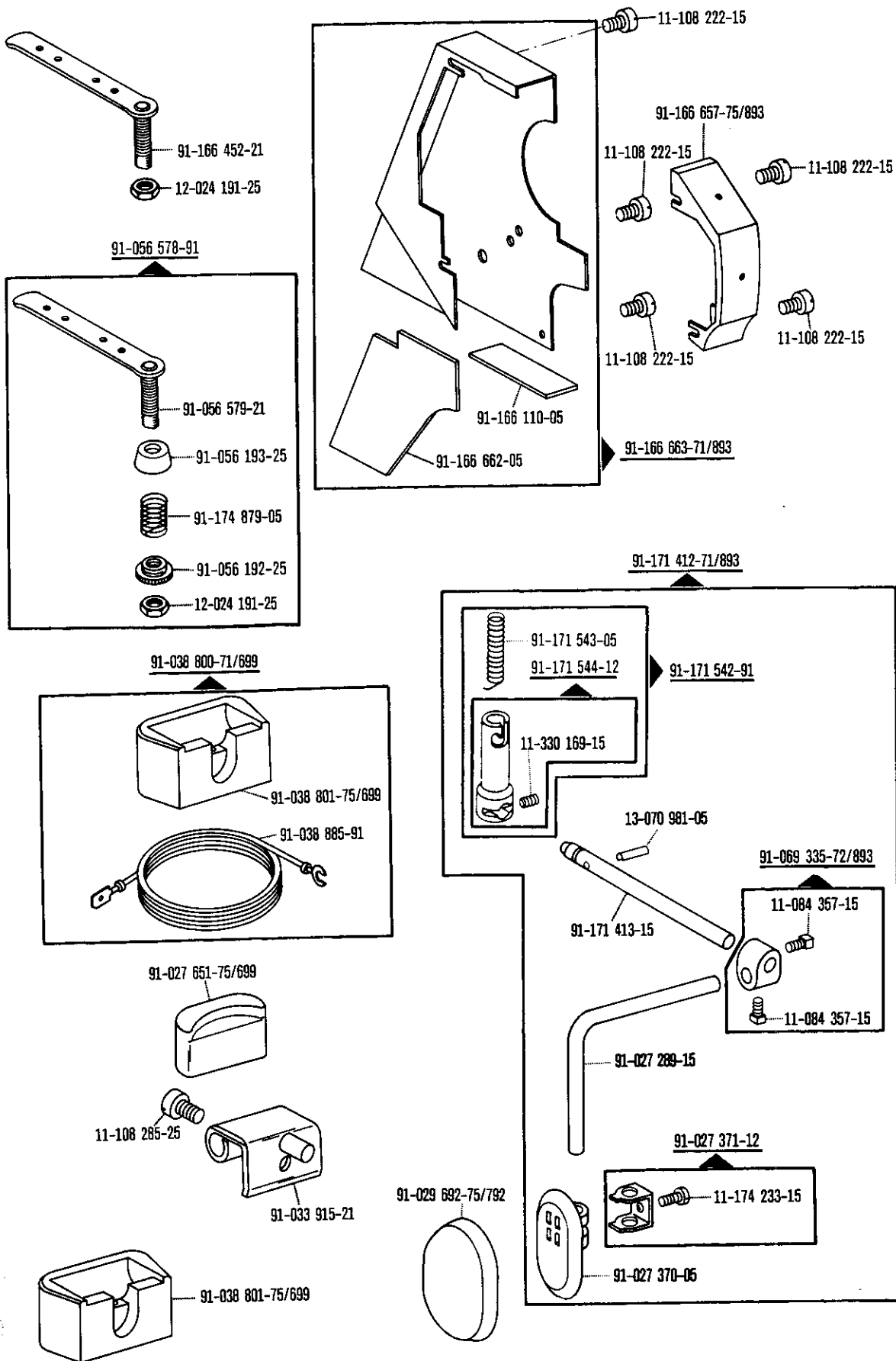

Accessory parts
Accessoires
Accesorios

zur - pour
for - para

PFAFF 422; 422-720/04
PFAFF 1422; 1422-720/04

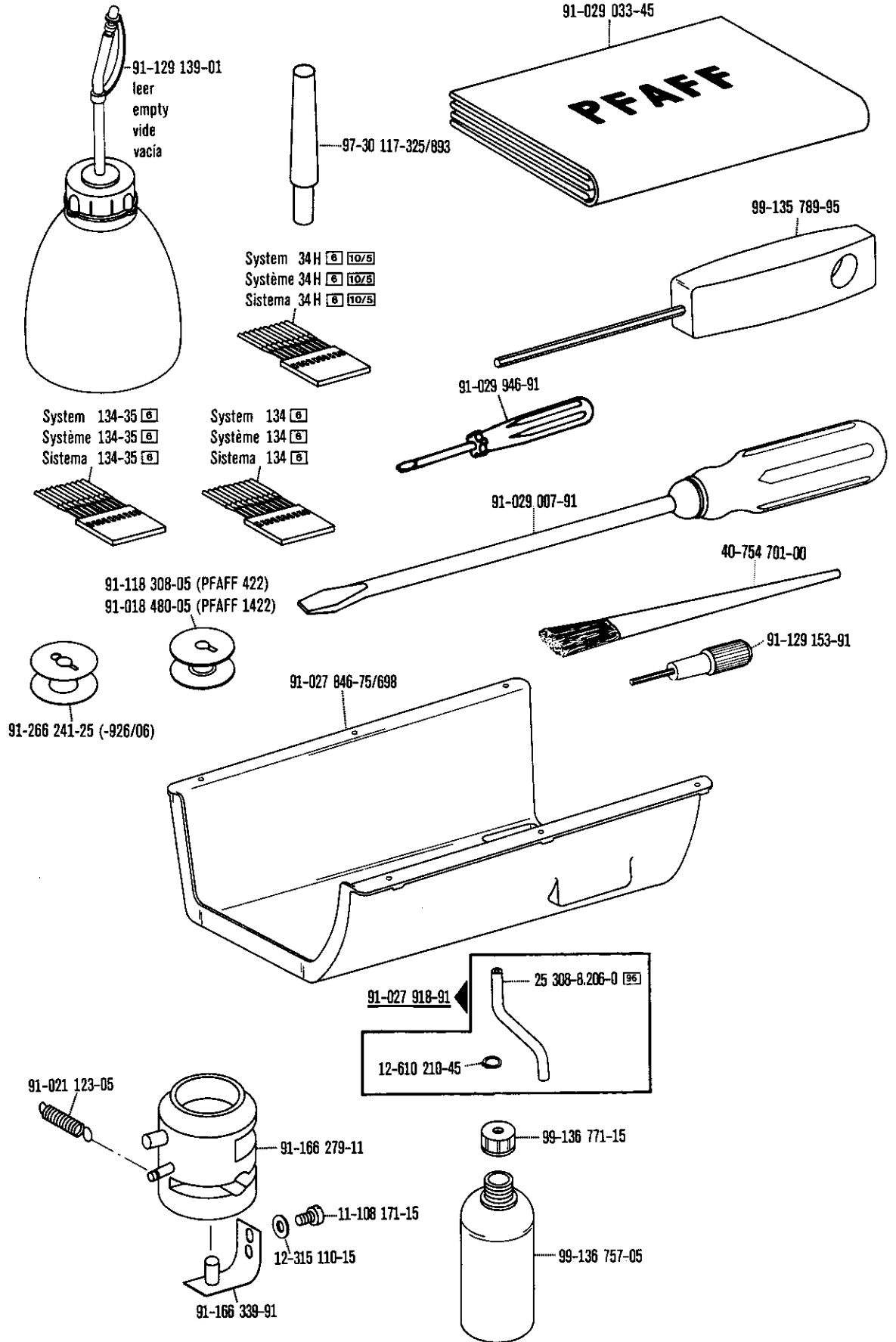

91-129 654-70/894

91-029 039-70/894

91-129 783-71/894

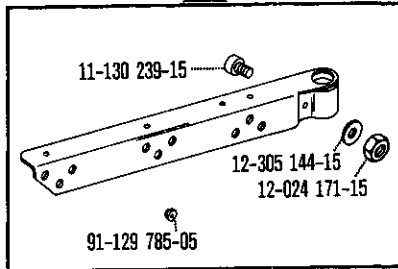

91-129 783-71/894

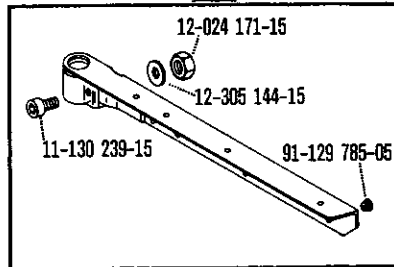

99-115 037-45

91-129 159-70/894

91-129 621-75/894

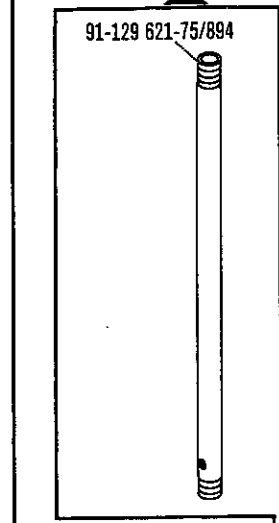

91-129 644-05

91-129 649-45

91-129 645-75/698

91-129 644-05

91-129 649-45

91-129 645-75/698

91-129 118-75/894

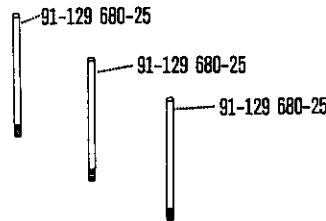
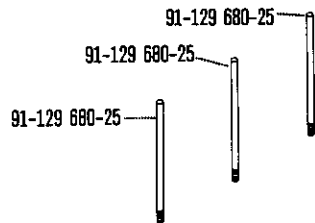
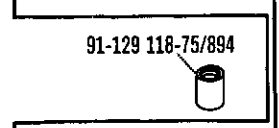

91-129 637-75/894

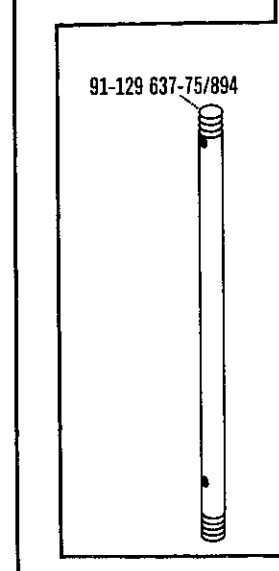

91-129 784-71/894

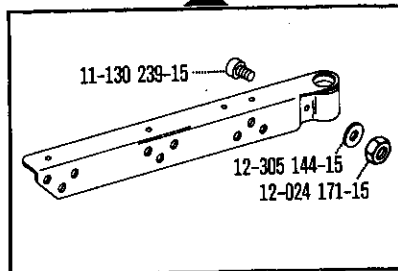

91-129 784-71/894

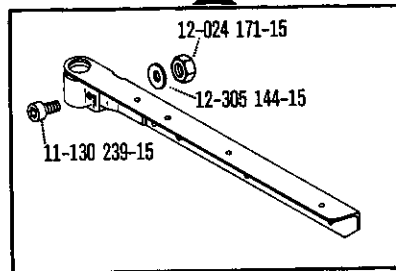

12-005 195-15

12-005 195-15

99-115 034-15
 12-305 414-15
 12-305 414-15
 99-115 034-15

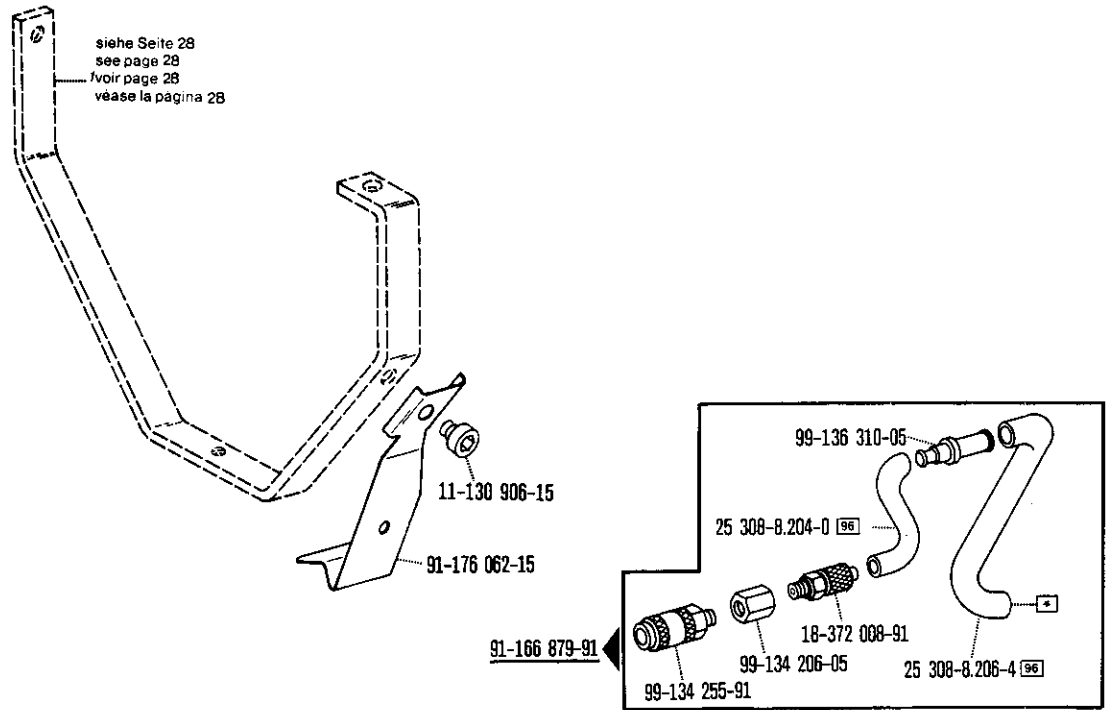

Einstellehren
Adjustment gauges
Calibres
Calibres de ajuste

zur - pour
for - para

PFAFF 422; 422-720/04
PFAFF 1422; 1422-720/04

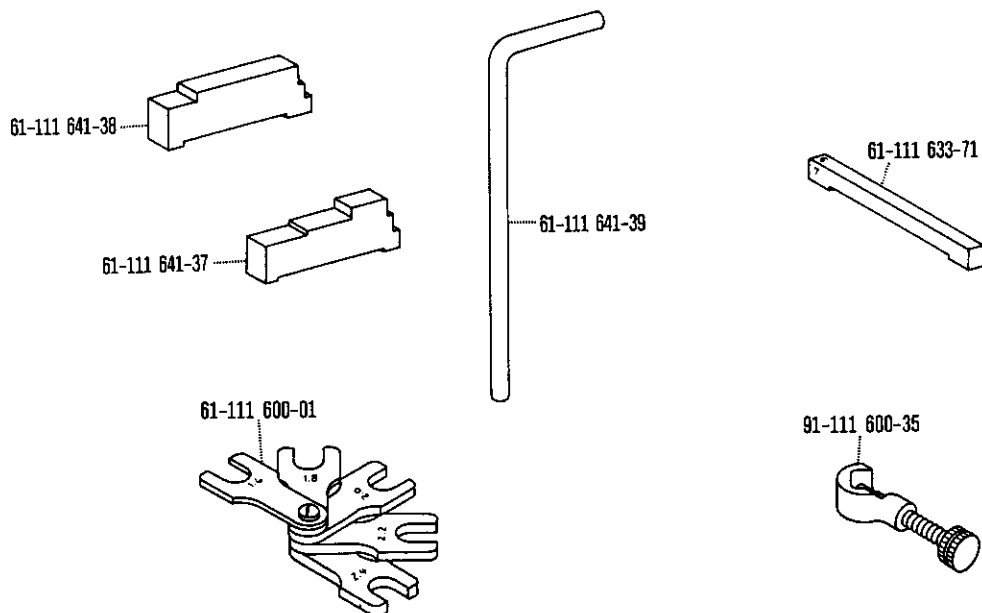





Table of V-belt pulleys
 Tableau des poulies à gorge en V
 Tabla de poleas para correas en "V"

PFAFF 422; 422-720/04
 PFAFF 1422; 1422-720/04

Nähgeschwindigkeit max., Stiche/min Maximum sewing speed in s.p.m. Nombre de points max./mn Numero max. de puntadas por minuto	Motordrehzahl U/min Motor speed in r.p.m. Régime moteur en tours/mn Regimen del motor en r.p.m.	Frequenz Frequency Fréquence Frecuencia	Handrad-Durchmesser ¹⁾ in mm Balance wheel diameter ¹⁾ in mm Diamètre du volant ¹⁾ en mm Diámetro del volante ¹⁾ en mm	Keilriemenscheiben-Durchmesser ¹⁾ in mm V-belt pulley diameter ¹⁾ in mm Diamètre de la poulie à gorge ¹⁾ en mm Diámetro de la polea para correa en "V" ¹⁾ en mm	Teilnummer der Keilriemenscheibe Part number of V-belt pulley Número de pièce des poulies à gorge en V Nº de las piezas de poleas para correas en "V"
PFAFF 422					
5000	2800	50 Hz	80	140	16-437 140-05
5000	3400	60 Hz	80	118	16-437 120-05
4500	2800	50 Hz	80	125	16-437 130-05
4500	3400	60 Hz	80	106	16-437 100-05
4000	2800	50 Hz	80	112	16-437 110-05
4000	3400	60 Hz	80	95	16-437 080-05
3500	2800	50 Hz	80	100	16-437 090-05
3500	3400	60 Hz	80	80	16-437 050-05
3000	2800	50 Hz	80	85	16-437 060-05
3000	3400	60 Hz	80	71	16-437 030-05
PFAFF 1422					
4000	2800	50 Hz	80	112	16-437 110-05
4000	3400	60 Hz	80	95	16-437 080-05
3500	2800	50 Hz	80	100	16-437 090-05
3500	3400	60 Hz	80	80	16-437 050-05
3000	2800	50 Hz	80	85	16-437 060-05
3000	3400	60 Hz	80	71	16-437 030-05
2500	2800	50 Hz	80	71	16-437 030-05
2500	3400	50 Hz	80	58	16-437 909-05
PFAFF 422-720/04					
4000	2800	50 Hz	80	112	16-437 110-05
4000	3400	60 Hz	80	95	16-437 080-05
3000	2800	50 Hz	80	85	16-437 060-05
3000	3400	60 Hz	80	71	16-437 030-05
PFAFF 1422-720/04					
4000	2800	50 Hz	80	112	16-437 110-05
4000	3400	60 Hz	80	95	16-437 080-05
3500	2800	50 Hz	80	100	16-437 090-05
3500	3400	60 Hz	80	80	16-437 050-05
3000	2800	50 Hz	80	85	16-437 060-05
3000	3400	50 Hz	80	71	16-437 030-05

¹⁾ Wirksamer Durchmesser

Öl Oil Huile Aceite	Mittelpunkts- Viskosität bei: Mean viscosity at: Viscosité moyenne à: Viscosidad media a:		Dichte bei: Density of: Densité à: Densidad a:		Bestellnummer für Behälter mit: Part number for can with: Numéro de commande pour récipients avec: Número de pedido para recipientes con:			
	°C	mm ² /s	°C	g/cm ³ (g/ml)	Liter Litre Litros			
280-1-120 144	40	22,0	15	0,865	80(ml)	91-027 630-91		
					0,25		91-129 916-91	
					1		91-129 917-91	
					5			91-129 919-91
					10			91-129 920-91
280-1-120 122	20	41,5	15	0,849	40(ml)	91-027 624-91		
					0,25			
					1		91-129 452-91	
					5			91-129 456-91
					10			91-129 541-91

Fett Grease Graisse Grasa	Penetration Penetration Pénétration Penetración	Tropfpunkt Drip-point Point de suintement Punto de goteo	Bestellnummer für Behälter mit: Part number for can with: Numéro de commande pour récipients avec: Número de pedido para recipientes con:			
			mm/10	°C	kg	
280-1-120 205			0,5			
			1			280-1-120 205
280-1-120 243	375-405	150	0,5	280-1-120 243		
			1			
280-1-120 247	220-250	185	0,5			
			1		280-1-120 247	

No.	Seite Page Pages Página	No.	Seite Page Pages Página	No.	Seite Page Pages Página	No.	Seite Page Pages Página
11-039 222-15	57	11-130 092-15	17, 41, 61, 65	11-132 172-15	41, 49	11-210 174-15	18, 19, 20, 21, 32, 33, 42, 43, 44, 45, 46, 47
11-039 225-15	12	11-130 097-15	50	11-132 217-15	30, 54		43
11-039 306-15	18, 19, 20, 21, 32, 33, 42, 43, 44, 45, 46, 47	11-130 101-15	50, 53	11-132 223-15	18, 20, 41, 42, 44, 62	11-210 178-15	43
11-084 357-15	67	11-130 167-15	11	11-133 538-15	26	11-210 186-15	23
11-106 947-15	37	11-130 170-15	50, 62	11-135 223-15	18, 19, 20, 21, 32, 33, 42, 43, 44, 45, 46, 47	11-210 210-15	18, 20, 21, 32, 33, 42, 43, 44, 45, 46, 47
11-108 168-15	39	11-130 173-15	66	11-135 226-15	16, 28	11-210 216-15	17, 26
11-108 171-15	18, 19, 20, 21, 22, 24, 32, 33, 42, 43, 44, 45, 46, 47, 53, 58, 68	11-130 176-15	25, 29, 37, 48, 49, 57, 61	11-135 238-15	17	11-210 295-15	16
11-108 171-25	17, 30	11-130 176-25	17	11-135 286-15	48	11-210 936-05	49
11-108 174-15	14, 22, 24, 30, 39, 54	11-130 179-15	36, 50, 54, 55, 57	11-135 292-15	17	11-225 094-15	19, 21, 33, 43, 45, 47
11-108 174-25	39	11-130 179-25	38	11-135 298-15	29	11-225 184-15	41, 65
11-108 177-15	66	11-130 197-15	37	11-135 929-15	14	11-225 223-15	41
11-108 180-15	31, 59	11-130 206-15	35	11-172 127-25	13, 51	11-225 312-15	55, 56
11-108 192-15	18, 19, 20, 21, 32, 33, 42, 43, 44, 45, 46, 47	11-130 209-15	37	11-173 171-15	37	11-250 076-25	31, 59, 62
11-108 204-15	39	11-130 224-15	16, 22, 26, 30, 36, 53, 54, 57, 58, 66	11-173 222-15	30, 53, 54, 55, 56, 57, 58	11-250 084-25	16
11-108 219-15	35	11-130 227-15	15	11-174 173-15	11	11-250 090-15	15
11-108 222-15	53, 67	11-130 233-15	25, 26, 28, 41	11-174 176-15	13	11-250 178-15	37
11-108 222-25	26, 28, 35	11-130 239-15	26, 28, 56, 69	11-174 233-15	67	11-305 299-15	53
11-108 225-15	25, 31	11-130 245-15	28	11-174 915-15	48	11-305 305-15	53
11-108 225-25	26	11-130 251-15	43, 45, 47, 57	11-180 169-95	17, 26, 61	11-305 314-15	15
11-108 234-15	15	11-130 263-15	66	11-187 009-15	51, 53	11-314 280-15	14, 41
11-108 237-25	26, 31	11-130 281-15	15	11-187 012-15	53	11-314 946-15	13, 22, 51
11-108 240-25	35	11-130 284-15	36	11-210 038-25	18, 20, 32, 42, 44, 46	11-314 964-15	49
11-108 250-25	26, 31, 35	11-130 287-15	35, 37, 48, 49	11-210 078-15	18, 19, 20, 21, 32, 33, 42, 44, 45, 46, 47	11-315 917-05	15
11-108 255-15	31, 49	11-130 293-15	15, 23, 24, 39, 48, 49	11-210 081-15	49, 53	11-317 167-15	18, 19, 20, 21, 32, 33, 42, 43, 44, 45, 46, 47
11-108 255-25	26, 31	11-130 299-15	27	11-210 084-25	66	11-317 171-05	26
11-108 285-15	26	11-130 305-15	27, 37	11-210 166-25	26	11-317 949-15	11, 27, 28
11-108 285-25	67	11-130 311-15	63	11-210 168-15	23, 39	11-317 950-05	47
11-108 294-15	26	11-130 533-15	26	11-210 168-25	16	11-317 950-15	18, 19, 20, 21, 32, 33, 42, 43, 44, 45, 46
11-130 089-15	13, 14, 51	11-130 906-15	38, 70	11-210 169-15	38	11-330 082-15	27
		11-130 914-15	63, 65			11-330 085-15	53
		11-132 169-15	13				

PFAFF 422; 422-720/04
PFAFF 1422; 1422-720/04

No.	Seite Page Pages Página	No.	Seite Page Pages Página	No.	Seite Page Pages Página	No.	Seite Page Pages Página
11-330 088-15	38	12-005 195-15	53, 69	12-500 151-45	66	13-033 469-05	15
11-330 166-15	12, 29, 36	12-005 901-15	55, 56	12-505 150-45	13, 37, 51	13-033 556-05	38
11-330 169-15	18, 19, 20, 21, 27, 32, 33, 42, 43, 44, 45, 46, 47, 55, 56, 67	12-024 121-15	50	12-505 190-45	51	13-052 046-55	18, 20, 32, 42, 44, 46
11-330 172-15	28, 36	12-024 121-25	66	12-517 200-45	38	13-052 142-15	41
11-330 217-15	38, 39, 43, 45, 47	12-024 151-15	14, 23, 39, 66	12-517 250-45	39	13-052 247-15	49
11-330 220-05	17	12-024 151-25	13, 51, 66	12-518 230-45	38	13-052 262-15	39
11-330 220-15	12, 61	12-024 171-15	28, 36, 48, 49, 56, 59, 66, 69	12-610 170-45	18, 19, 20, 21, 32, 33, 42, 43, 44, 45, 46, 47	13-060 316-05	26
11-330 223-15	25, 29	12-024 191-15	15, 23	12-610 190-45	38	13-060 400-05	26
11-330 232-15	17, 61	12-024 191-25	67	12-610 200-45	18, 19, 20, 21, 32, 33, 42, 43, 44, 45, 46, 47	13-060 902-05	29
11-330 244-15	36	12-024 231-25	36	12-610 210-45	12, 27, 35, 68	13-060 903-05	27
11-330 283-15	27	12-305 084-15	50	12-610 230-45	19, 21, 33, 38, 43, 45, 47	13-060 904-05	29
11-330 952-15	14, 23, 25, 28, 37, 39	12-305 084-25	13, 51	12-610 250-45	15, 17, 39, 48, 49	13-064 259-05	48
11-330 955-15	27	12-305 114-15	37	12-610 280-45	22	13-064 388-05	25, 26
11-330 960-15	14, 23, 28, 29	12-305 144-15	28, 57, 69	12-610 290-45	18, 20, 23, 32, 42, 44, 46	13-065 088-05	23
11-330 964-15	23	12-305 174-15	23, 29, 37, 49, 53	12-610 310-45	11, 27	13-070 981-05	55, 56, 67
11-335 902-15	16, 18, 19, 20, 21, 23, 32, 33, 42, 43, 44, 45, 46, 47	12-305 414-15	69	12-610 330-45	19, 21, 33, 35, 43, 45, 47	14-010 173-01	25, 38
11-341 166-15	49	12-315 080-15	41, 65	12-624 210-45	41	14-012 555-01	35
11-341 217-15	53	12-315 090-15	51	12-640 130-05	61	14-012 562-01	18, 19, 20, 21, 32, 33, 42, 43, 44, 45, 46, 47
11-341 901-15	15, 22, 23	12-315 090-25	13	12-640 130-55	16, 38, 39, 59	14-016 120-01	23
11-341 902-15	23, 25, 35, 38	12-315 110-15	66, 68	12-640 150-55	53, 59	14-016 150-01	16, 28
11-341 904-15	38	12-315 170-15	36	12-640 170-55	14, 36, 37, 41	14-016 151-91	16, 18, 19, 20, 21, 32, 33, 35, 42, 43, 44, 45, 46, 47
11-341 905-15	16, 18, 19, 20, 21, 23, 27, 32, 33, 35, 42, 43, 44, 45, 46, 47	12-335 151-15	24	12-640 200-55	41	14-016 153-01	16, 18, 19, 20, 21, 32, 33, 35, 43, 44, 45, 46, 47
11-460 403-15	66	12-335 191-15	63	12-640 220-55	14	14-016 171-91	48
11-724 270-55	66	12-349 082-05	19, 20, 21, 32, 33, 42, 43, 44, 45, 46, 47	12-660 430-45	39	14-016 173-01	48
11-724 290-55	17	12-349 082-15	18, 46	12-703 161-12	53	14-018 590-01	39
12-005 154-15	13, 51, 53	12-360 054-05	41	13-030 310-05	15	14-018 613-01	23
12-005 175-15	17, 61	12-360 063-25	27	13-030 389-05	25	14-018 614-91	23
		12-360 103-05	48	13-033 004-05	18, 19, 20, 21, 32, 33, 42, 43, 44, 45, 46, 47	14-018 643-01	16, 28
		12-360 173-05	17			14-018 644-91	16, 28
		12-361 156-15	16				

PFAFF 422; 422-720/04
PFAFF 1422; 1422-720/04

No.	Seite Page Pages Página	No.	Seite Page Pages Página	No.	Seite Page Pages Página	No.	Seite Page Pages Página
14-026 122-01	18, 19, 20, 21, 32, 33, 42, 44, 45, 46, 47	15-120 904-05	37	61-111 641-38	70	91-010 546-05	52
14-215 007-13	38	15-120 911-05	52	61-111 641-39	70	91-010 633-05	14
14-215 013-03	29	15-120 916-05	18, 19, 20, 21, 32, 33, 42, 43, 44, 45, 46, 47	71-13 00-0591	31	91-011 374-05	17
14-215 013-13	12, 22, 27, 38	15-120 919-05	39	71-13 00-0592	31	91-011 391-05	26
14-215 022-13	12, 18, 19, 20, 21, 32, 33, 38, 42, 43, 44, 45, 46, 47	15-125 049-05	62	71-13 00-0593	31	91-018 293-05	18, 20, 32, 42, 44, 46
14-215 028-13	15, 23, 38, 39	15-256 055-01	39	71-13 00-0594	31	91-018 439-05	32, 46
14-215 043-43	36	15-280 022-01	39	71-13 00-0595	31, 62	91-018 480-05	20, 44, 46, 68
14-215 046-13	29	16-409 916-05	36	71-13 00-0596	31	91-018 578-05	36
14-215 049-43	38	16-437 030-05	71	71-13 00-0597	62	91-018 958-05	32, 46
14-215 070-13	28, 29	16-437 050-05	71	71-13 00-0599	31, 62	91-020 086-15	18, 19, 20, 21, 32, 33, 42, 43, 44, 45, 46, 47
14-215 118-13	22	16-437 060-05	71	71-13 00-0602	31, 62	91-020 490-15	15, 56
14-215 124-13	22	16-437 080-05	71	71-16 00-0187	66	91-021 123-05	68
14-215 157-13	28	16-437 090-05	71	71-17 00-0131	50	91-021 344-15	37
14-215 166-13	11, 27	16-437 100-05	71	71-21 00-0174	50	91-027 289-15	67
14-215 199-43	23	16-437 110-05	71	71-31 00-0107	65	91-027 370-05	67
14-215 382-13	29	16-437 120-05	71	71-37 00-0132	11, 24, 28, 50, 52	91-027 371-12	67
14-215 904-13	25	16-437 130-05	71	71-37 00-0133	50	91-027 624-91	72
14-215 905-13	28	16-437 140-05	71	71-85 00-0091	66	91-027 630-91	72
14-218 040-01	37	16-437 909-05	71	91-000 219-05	18, 20, 32, 42, 44, 46	91-027 651-75/699	67
14-602 901-01	16	17-028 318-61	38	91-000 249-15	32, 46	91-027 846-75/698	68
14-650 243-05	57	17-035 232-45	36	91-000 390-05	18, 20, 32, 42, 44, 46	91-027 918-91	68
14-650 251-05	23	18-278 005-91	65	91-000 529-15	18, 20, 32, 42, 44, 46	91-029 007-91	68
14-680 030-15	23	18-279 010-05	65	91-000 742-15	13, 51	91-029 033-45	68
14-680 060-15	16, 18, 19, 20, 21, 32, 33, 35, 43, 44, 45, 46, 47	18-372 008-91	30, 54, 57, 62, 65, 70	91-000 928-15	18, 20, 32, 42, 44, 46	91-029 039-70/894	69
14-680 070-15	16, 28, 48 55, 56, 57, 58, 65	18-378 008-61	28	91-001 283-15	38	91-029 692-75/792	67
15-120 707-05	18, 20, 32, 42, 44, 46	18-378 008-91	52, 53, 55, 56, 59, 61, 62, 65	91-001 522-25	51	91-029 946-91	68
15-120 718-05	17, 38	18-379 008-91	52	91-002 065-05	13, 51	91-030 357-05	43, 45, 47
15-120 902-05	20, 32, 44, 46	40-754 701-00	68	91-002 262-25	13	91-033 765-15	23
		61-111 341-37	70	91-006 526-05	14	91-033 915-21	67
		61-111 600-01	70	91-006 584-05	13, 51	91-038 800-71/699	67
		61-111 633-71	70	91-010 055-25	52	91-038 801-75/699	67
				91-010 178-05	18, 42	91-038 885-91	67
				91-010 183-05	13		

PFAFF 422; 422-720/04
PFAFF 1422; 1422-720/04

No.	Seite Page Pages Página	No.	Seite Page Pages Página	No.	Seite Page Pages Página	No.	Seite Page Pages Página
91-056 192-25	67	91-101 923-05	51	91-118 430-25	13	91-118 884-45	22
91-056 193-25	67	91-105 447-15	51	91-118 569-04	16	91-118 886-92	22
91-056 351-05	66	91-105 447-25	13	91-118 570-92	16	91-118 887-05	22
91-056 578-91	67	91-106 143-05	25	91-118 600-91	22	91-118 888-05	22
91-056 579-21	67	91-106 272-12	38	91-118 609-15	15	91-118 889-12	22
91-069 042-01	29	91-107 266-05	38	91-118 612-05	15	91-118 893-92	22
91-069 079-72/985	14	91-107 886-15	17	91-118 681-05	16	91-118 894-05	22
91-069 292-05	26	91-110 918-75/893	66	91-118 682-05	16	91-118 898-05	23
91-069 335-72/893	67	91-111 600-35	70	91-118 683-05	16	91-118 901-12	23
91-069 471-25	13, 51	91-113 023-92	51	91-118 685-05	16	91-118 931-05	16
91-089 467-05	59	91-113 023-93	13	91-118 703-11	18, 19, 20, 21, 32, 33, 42, 43, 44, 45, 46, 47	91-118 934-91	16
91-090 751-05	50	91-113 027-15	13, 51	91-118 704-15	18, 19, 20, 21, 32, 33, 42, 43, 44, 45, 46, 47	91-118 935-05	16
91-090 823-91	50	91-113 445-15	59, 61	91-118 709-15	18, 20, 32, 42, 44, 46	91-118 937-01	16
91-091 818-91	66	91-118 019-91	15	91-118 711-05	18, 19, 20, 21, 32, 33, 42, 43, 44, 45, 46, 47	91-118 939-21	16
91-094 619-73/001	17	91-118 022-05	48	91-118 717-72/895	22	91-118 940-05	16
91-094 737-91	50	91-118 044-91	22	91-118 762-05	18, 19, 20, 21, 32, 33, 42, 43, 44, 45, 46, 47	91-119 006-01	12
91-094 738-91	55, 56	91-118 045-91	22	91-118 765-05	18, 19, 20, 21, 32, 33, 42, 43, 44, 46, 47	91-119 010-04	12
91-094 739-91	57	91-118 098-25	16	91-118 766-05	39	91-119 015-15	11
91-094 741-91	59	91-118 099-91	16	91-118 785-05	45	91-119 049-05	12, 27
91-094 743-91	30	91-118 137-91	23	91-118 787-15	18, 20, 21, 32, 33, 42, 43, 44, 45, 46, 47	91-119 085-05	22
91-094 744-91	30	91-118 138-93	23	91-118 790-07	18, 19, 20, 21, 32, 33, 42, 43, 44, 45, 46, 47	91-119 120-91	23
91-094 745-91	53	91-118 144-05	41	91-118 857-05	15	91-119 121-12	23
91-094 935-91	62	91-118 148-05	15	91-118 880-91	22	91-119 702-91	16
91-095 850-91	50	91-118 150-72/951	26, 65	91-118 881-15	22	91-119 704-91	16
91-098 827-15	36	91-118 150-75/951	26	91-118 882-92	22	91-119 705-12	16
91-100 065-25	52	91-118 151-05	26	91-118 883-05	22	91-129 118-75/894	69
91-100 270-25	52	91-118 152-05	26	91-118 884-45	22	91-129 139-01	68
91-100 281-25	16	91-118 154-90	18, 19, 42, 43	91-118 885-05	15	91-129 153-91	68
91-100 355-05	11	91-118 178-07	22	91-118 886-92	22	91-129 159-70/894	69
91-101 181-15	51	91-118 196-12	11	91-118 887-05	15	91-129 452-91	72
91-101 185-05	13	91-118 274-91	16	91-118 888-05	22	91-129 456-91	72
91-101 920-05	35	91-118 275-93	16	91-118 889-12	22	91-129 541-91	72
91-101 922-05	13, 51	91-118 308-05	18, 42, 68	91-118 893-92	22	91-129 621-75/894	69

PFAFF 422; 422-720/04
PFAFF 1422; 1422-720/04

No.	Seite Page Pages Página	No.	Seite Page Pages Página	No.	Seite Page Pages Página	No.	Seite Page Pages Página
91-129 637-75/894	69	91-166 013-04	27	91-166 057-05	29	91-166 118-05	53
91-129 644-05	69	91-166 015-91	27	91-166 058-05	29	91-166 119-05	53
91-129 645-75/698	69	91-166 017-01	27	91-166 059-05	29	91-166 120-91	53
91-129 649-45	69	91-166 021-04	27	91-166 060-04	29	91-166 126-91	62
91-129 654-70/894	69	91-166 022-05	27	91-166 061-05	29	91-166 129-15	30, 53, 54, 57, 58
91-129 680-25	69	91-166 023-05	26	91-166 063-92	29	91-166 130-04	27
91-129 783-71/894	69	91-166 024-92	27	91-166 065-92	29	91-166 131-91	27
91-129 784-71/894	69	91-166 026-92	27	91-166 066-04	29	91-166 148-72/951	23
91-129 785-05	69	91-166 027-91	27	91-166 068-05	29	91-166 150-05	27
91-129 916-91	72	91-166 028-01	27	91-166 071-05	29	91-166 151-05	27
91-129 917-91	72	91-166 031-05	27	91-166 072-45	28	91-166 156-71/893	61
91-129 919-91	72	91-166 032-12	27	91-166 075-72/895	26	91-166 157-75/893	17, 61
91-129 920-91	72	91-166 033-05	27	91-166 077-25	28	91-166 160-15	17, 61
91-130 035-07	49	91-166 034-01	14	91-166 078-75/895	31	91-166 162-15	61
91-130 185-15	37	91-166 036-12	14	91-166 085-05	28	91-166 163-05	17, 61
91-131 019-15	48	91-166 037-25	14	91-166 087-05	14	91-166 164-11	17, 61
91-140 199-02	18, 20, 32, 42, 44, 46	91-166 038-91	28	91-166 088-11	14	91-166 167-05	61
91-140 239-05	18, 19, 20, 21, 32, 33, 42, 43, 44, 45, 46, 47	91-166 039-05	28	91-166 091-91	28	91-166 168-05	17, 61
91-140 242-05	24	91-166 040-05	28	91-166 092-71/895	53	91-166 169-05	61
91-140 945-05	18, 20, 32, 42, 44, 46	91-166 042-05	28	91-166 094-04	27	91-166 170-05	17, 61
91-141 543-05	18, 19, 20, 21, 32, 33, 42, 43, 44, 45, 46, 47	91-166 043-05	28	91-166 095-15	53	91-166 171-05	17, 61
91-162 526-05	23	91-166 044-05	28	91-166 099-71/895	26	91-166 177-05	17, 61
91-162 630-01	18, 42	91-166 045-92	28	91-166 102-05	29	91-166 178-05	17, 61
91-162 632-91	18, 42	91-166 048-05	27	91-166 103-05	29	91-166 180-75/893	61
91-162 633-05	18, 42	91-166 049-05	29	91-166 104-05	28	91-166 181-71/698	17
91-162 634-05	18, 42	91-166 050-05	28	91-166 105-05	28	91-166 182-11	17
91-162 635-05	18, 19, 42, 43, 45, 47	91-166 050-92	28	91-166 107-05	26	91-166 185-05	17
91-163 088-75/698	17	91-166 051-91	29	91-166 110-05	35, 67	91-166 186-12	17
91-166 001-75/895	26	91-166 053-04	29	91-166 113-15	28	91-166 187-92	59
91-166 008-92	28	91-166 054-04	29	91-166 114-05	53	91-166 189-91	53, 58
91-166 009-91	27	91-166 055-05	29	91-166 115-15	53	91-166 190-91	54, 57
		91-166 056-05	29	91-166 116-91	53	91-166 194-75/895	35
				91-166 117-91	53	91-166 195-72/895	26

No.	Seite Page Pages Página	No.	Seite Page Pages Página	No.	Seite Page Pages Página	No.	Seite Page Pages Página
91-166 196-72/895	31	91-166 394-71/951	23	91-166 623-75/893	17	91-166 827-05	20, 32, 44, 46
91-166 197-91	30, 54	91-166 396-11	41	91-166 625-72/895	26	91-166 828-05	20, 44, 46
91-166 198-15	62	91-166 406-91	35	91-166 652-75/699	26	91-166 835-05	59
91-166 278-91	56	91-166 407-11	35	91-166 657-75/893	67	91-166 836-05	31, 62
91-166 279-11	68	91-166 411-91	35	91-166 662-05	35, 67	91-166 853-91	59
91-166 281-15	56	91-166 413-75/893	35	91-166 663-71/893	67	91-166 858-75/893	52
91-166 282-15	56	91-166 414-75/895	35	91-166 665-05	26	91-166 859-75/895	52
91-166 283-11	56	91-166 416-91	37	91-166 672-05	29	91-166 874-15	17
91-166 311-01	29	91-166 417-11	37	91-166 675-90	55	91-166 879-91	70
91-166 312-05	29	91-166 420-15	37	91-166 676-91	55, 56	91-166 881-75/699	17, 61
91-166 313-05	29	91-166 421-71/895	37	91-166 677-90	59	91-166 882-71/699	17, 61
91-166 320-05	25	91-166 422-71/895	37	91-166 691-70/893	61	91-166 883-71/699	61
91-166 322-05	22	91-166 427-12	37	91-166 717-15	26	91-166 893-91	15
91-166 323-05	23	91-166 434-05	37	91-166 718-15	55, 56	91-166 894-15	15
91-166 324-05	23	91-166 436-91	36	91-166 725-01	26	91-166 911-71/895	26
91-166 329-91	22	91-166 438-91	36	91-166 726-71/895	26	91-166 915-05	14
91-166 339-91	68	91-166 439-15	36	91-166 727-71/893	35	91-166 919-91	20, 44
91-166 376-91	20, 21, 32, 33, 44, 45, 46, 47	91-166 440-71/895	35	91-166 729-15	18, 42	91-166 923-11	17
91-166 377-05	20, 21, 32, 33, 44, 45, 46, 47	91-166 445-15	57	91-166 730-05	18, 19, 42, 43	91-166 927-11	61
91-166 378-05	20, 44	91-166 446-91	57	91-166 731-75/951	18, 19, 42, 43, 45, 47	91-166 929-05	61
91-166 381-75/951	20, 21, 32, 33, 44, 46	91-166 447-05	57	91-166 732-91	18, 19, 42, 43	91-166 942-71/698	13
91-166 382-05	20, 21, 32, 33, 44, 46	91-166 448-05	57	91-166 733-91	18, 42	91-167 636-05	49
91-166 383-05	44	91-166 449-15	57	91-166 740-01	32, 46	91-168 039-05	12
91-166 383-15	18, 19, 20, 21, 32, 33, 42, 43, 45, 46, 47	91-166 451-90	57	91-166 811-05	25	91-168 046-15	12
91-166 384-05	18, 19, 20, 21, 32, 33, 42, 43, 44, 45, 46, 47	91-166 452-21	67	91-166 812-05	25	91-168 047-14	12
91-166 388-05	18, 20, 32, 42, 44, 46	91-166 493-05	12, 27	91-166 814-01	25	91-168 054-92	16
91-166 390-05	18, 20, 32, 42, 44, 46	91-166 552-02	23	91-166 816-91	52	91-168 055-91	16
91-166 390-92	18, 20, 32, 42, 44, 46	91-166 553-05	23	91-166 817-25	52	91-168 099-04	35
91-166 391-15	18, 20, 32, 42, 44	91-166 554-05	23	91-166 818-25	52	91-168 105-05	38
		91-166 559-25	26	91-166 819-05	52	91-168 194-71/698	13
		91-166 596-15	29	91-166 821-25	52	91-168 391-15	46
		91-166 620-71/893	17	91-166 822-25	52	91-168 480-15	16
		91-166 621-05	17	91-166 823-25	52	91-168 757-01	37

No.	Seite Page Pages Página	No.	Seite Page Pages Página	No.	Seite Page Pages Página	No.	Seite Page Pages Página
91-168 828-05	32	91-173 297-92	14	91-173 844-91	14	91-173 934-75/951	49
91-168 835-05	31	91-173 501-71/951	49	91-173 845-11	14	91-173 935-05	49
91-169 099-75/768	28	91-173 502-75/951	49	91-173 849-05	14	91-173 936-05	49
91-169 132-15	23	91-173 504-92	49	91-173 850-05	14	91-173 959-11	53
91-169 582-05	38	91-173 505-05	49	91-173 854-05	14	91-173 972-05	18, 19, 20, 21, 32, 33, 42, 43, 44, 45, 46, 47
91-170 809-05	28	91-173 506-05	49	91-173 874-11	41	91-173 973-15	18, 19, 20, 21, 32, 33, 42, 43, 44, 45, 46, 47
91-171 042-45	16	91-173 507-05	49	91-173 876-05	41	91-173 975-11	53
91-171 049-05	16	91-173 509-15	50	91-173 877-05	41	91-173 988-05	23
91-171 175-12	23, 39	91-173 516-05	49	91-173 878-05	41	91-173 989-91	12
91-171 412-71/893	67	91-173 517-92	49	91-173 879-05	41	91-173 990-05	12
91-171 413-15	67	91-173 524-77/951	26	91-173 880-05	41	91-174 344-92	16
91-171 542-91	55, 67	91-173 538-15	48	91-173 881-05	41	91-174 609-15	35
91-171 543-05	55, 56, 67	91-173 539-15	48	91-173 882-05	41	91-174 616-71/895	39
91-171 544-12	55, 56, 67	91-173 541-15	41	91-173 883-91	41	91-174 617-75/895	39
91-171 982-70/893	63	91-173 545-91	48	91-173 885-15	41	91-174 618-05	39
91-172 910-05	55, 56	91-173 546-05	48	91-173 886-05	14	91-174 619-05	39
91-173 024-01	12	91-173 553-05	41	91-173 894-91	41	91-174 620-71/895	38
91-173 027-92	12	91-173 556-72/951	48	91-173 899-91	49	91-174 621-15	39
91-173 028-05	12	91-173 559-72/951	48	91-173 900-02	49	91-174 622-05	39
91-173 049-05	35	91-173 562-05	48	91-173 901-05	49	91-174 623-71/895	38
91-173 072-05	25	91-173 572-05	18, 19, 20, 21, 32, 33, 42, 43, 44, 45, 46, 47	91-173 902-91	48	91-174 624-01	38
91-173 079-92	25	91-173 588-15	53	91-173 906-24	22	91-174 626-05	38
91-173 084-05	22	91-173 589-15	53	91-173 907-24	22	91-174 627-75/895	38
91-173 085-05	23	91-173 594-15	49	91-173 911-05	42, 44, 46	91-174 628-91	38
91-173 093-05	25	91-173 595-15	50	91-173 914-15	18, 19, 20, 21, 32, 33, 42, 43, 44, 45, 46, 47	91-174 629-05	38
91-173 094-15	25	91-173 674-15	49	91-173 915-92	18, 19, 20, 21, 32, 33, 42, 43, 44, 45, 46, 47	91-174 630-92	38
91-173 100-05	17	91-173 676-15	14	91-173 924-11	43, 45, 47	91-174 631-05	38
91-173 102-05	26	91-173 839-05	49	91-173 926-05	49	91-174 632-05	38
91-173 106-05	23	91-173 840-92	15	91-173 927-15	43, 45, 47	91-174 633-05	38
91-173 133-15	55, 56	91-173 841-01	15	91-173 929-05	43, 45, 47	91-174 634-05	38
91-173 134-92	55, 56	91-173 842-05	15	91-173 933-71/951	49	91-174 635-01	38
91-173 139-15	59, 61	91-173 843-02	15				
91-173 297-01	14						

PFAFF 422; 422-720/04
PFAFF 1422; 1422-720/04

No.	Seite Page Pages Página	No.	Seite Page Pages Página	No.	Seite Page Pages Página	No.	Seite Page Pages Página
91-174 639-05	38	91-176 074-05	14	91-176 309-05	11	91-176 431-05	13
91-174 640-05	38	91-176 075-02	18, 19, 20, 21, 32, 33,	91-176 311-91	12	91-176 432-05	49
91-174 641-12	38		42, 43, 44, 45, 46, 47	91-176 312-01	12	91-176 433-05	49
91-174 646-05	38	91-176 076-91	43, 45, 47	91-176 314-05	12	91-176 435-05	48
91-174 647-05	38	91-176 077-15	43, 45, 47	91-176 315-05	12, 27	91-176 456-91	51
91-174 648-12	39	91-176 088-91	49	91-176 317-04	12	91-176 457-25	51
91-174 649-91	39	91-176 089-05	49	91-176 318-71/698	13	91-176 458-21	51
91-174 650-91	39	91-176 090-05	49	91-176 319-05	13, 51	91-176 460-15	51
91-174 652-11	39	91-176 091-05	49	91-176 320-25	13	91-176 461-21	51
91-174 654-05	39	91-176 092-02	49	91-176 321-05	13, 51	91-176 462-05	51
91-174 655-05	39	91-176 093-05	41	91-176 322-05	13, 51	91-176 463-05	51
91-174 656-92	39	91-176 094-05	41	91-176 323-05	13, 51	91-176 464-05	51
91-174 657-91	39	91-176 095-91	49	91-176 324-25	13, 51	91-176 465-05	51
91-174 665-75/895	39	91-176 096-15	49	91-176 326-15	13, 51	91-176 468-15	13, 51
91-174 666-15	39	91-176 103-91	48	91-176 327-25	13, 51	91-176 585-05	38
91-174 667-05	38	91-176 147-05	38	91-176 329-05	13, 51	91-176 587-05	38
91-174 668-05	39	91-176 177-91	16	91-176 330-25	13, 51	91-176 589-05	38
91-174 669-75/895	39	91-176 198-05	11	91-176 331-15	13	91-176 604-05	38
91-174 783-05	16	91-176 199-92	11	91-176 332-25	13	91-176 624-01	39
91-174 791-05	38	91-176 204-05	11, 27	91-176 335-25	13	91-176 625-05	39
91-174 879-05	67	91-176 207-91	16	91-176 336-05	13, 51	91-176 626-05	39
91-174 934-05	38	91-176 242-15	56	91-176 349-91	11	91-176 628-05	39
91-174 966-72/895	38	91-176 254-71/951	25	91-176 350-91	15	91-176 630-05	39
91-174 968-75/895	38	91-176 255-04	25	91-176 351-12	15	91-176 633-15	39
91-174 975-15	38	91-176 256-04	25	91-176 352-05	13, 51	91-176 667-05	38
91-174 977-25	38	91-176 257-05	25	91-176 353-05	13	91-176 721-02	37
91-175 354-15	53	91-176 258-92	25	91-176 354-25	13, 51	91-176 723-02	37
91-175 690-05	18, 42	91-176 259-05	25	91-176 355-25	13, 51	91-176 730-15	37
91-175 808-05	46	91-176 261-92	25	91-176 356-05	13, 51	91-176 731-15	37
91-175 908-05	20, 32, 44	91-176 288-05	18, 42	91-176 357-05	41	91-176 741-92	36
91-176 052-25	22	91-176 289-05	18, 42	91-176 373-21	13, 51	91-176 755-92	36
91-176 062-15	70	91-176 290-05	18, 42	91-176 377-25	13, 51	91-176 756-05	36
91-176 063-15	53, 59	91-176 302-05	12	91-176 378-05	13, 51	91-176 784-25	36

No.	Seite Page Pages Página	No.	Seite Page Pages Página	No.	Seite Page Pages Página	No.	Seite Page Pages Página
91-176 793-75/895	36	91-266 094-92	36	91-266 214-71/895	26	91-266 303-11	17, 61
91-176 806-12	36	91-266 095-01	37	91-266 216-90	20, 21, 32, 33, 44, 45, 46, 47	91-266 306-91	65
91-176 849-15	37	91-266 098-25	37	91-266 218-15	18, 19, 20, 21, 32, 33, 42, 43, 44, 45, 46	91-266 308-21	17, 61
91-176 930-05	41	91-266 117-72/893	16	91-266 219-72/951	18, 19, 20, 21, 32, 42, 43, 44, 45, 46, 47	91-266 310-05	24
91-177 322-15	37	91-266 130-91	20, 44	91-266 219-75/951	33	91-266 312-90	65
91-177 325-01	37	91-266 132-05	20, 44	91-266 220-12	19, 21, 33, 43, 45, 47	91-266 313-90	65
91-177 327-01	37	91-266 133-01	20, 44	91-266 221-15	19, 21, 33, 43, 45, 47	91-266 315-91	41
91-177 330-05	37	91-266 136-05	20, 32, 44, 46	91-266 222-15	19, 21, 33, 43, 45, 47	91-266 316-91	41
91-177 331-05	37	91-266 137-05	36	91-266 223-12	18, 20, 42, 44, 46	91-266 331-91	11
91-177 334-01	36	91-266 138-91	18, 19, 20, 21, 32, 42, 43, 44, 45, 46, 47	91-266 224-15	18, 20, 44, 46	91-266 335-01	11
91-177 357-45	11	91-266 139-15	18, 19, 20, 21, 32, 33, 42, 43, 44, 45, 46, 47	91-266 225-15	43, 45	91-266 340-05	24
91-177 592-05	37	91-266 140-15	24	91-266 226-05	19, 21, 33, 43, 45, 47	91-266 398-15	65
91-177 933-05	37	91-266 141-71/951	48	91-266 227-11	18, 20, 32, 42, 44, 46	91-266 940-05	24
91-178 010-15	36	91-266 142-72/951	48	91-266 230-91	23	91-290 001-91	50
91-178 227-05	37	91-266 143-71/951	48	91-266 231-92	23	91-290 495-91	66
91-178 659-12	35	91-266 147-15	24	91-266 232-12	18, 19, 20, 21, 32, 33, 42, 43, 44, 45, 46, 47	91-290 577-91	66
91-186 657-05	20, 44	91-266 163-05	37	91-266 233-12	18, 19, 20, 21, 32, 33, 42, 43, 44, 45, 46, 47	91-290 659-71/895	66
91-186 659-15	41, 65	91-266 165-71/895	36	91-266 234-12	45	91-291 105-71/699	62
91-186 661-15	41, 65	91-266 169-71/895	37	91-266 234-92	43, 47	91-291 128-71/699	59
91-187 208-71/993	66	91-266 185-15	37	91-266 236-15	48	91-291 131-71/699	31
91-187 293-75/893	63	91-266 186-15	37	91-266 241-25	65, 68	91-700 173-15	22
91-187 771-71/951	65	91-266 187-15	37	91-266 243-05	25	91-700 249-15	41, 65
91-187 968-15	66	91-266 188-15	37	91-266 257-01	24	91-700 412-25	13
91-188 163-15	41	91-266 189-91	33	91-266 288-15	18, 19, 20, 21, 32, 33, 42, 43, 44, 45, 46, 47	91-700 510-15	16, 23
91-188 583-05	52	91-266 198-71/951	21	91-266 289-72/951	48	91-700 689-15	16, 22
91-266 055-91	32, 46	91-266 199-71/951	45	91-266 298-15	41	91-700 785-15	14
91-266 056-91	32, 46	91-266 201-71/951	43	91-266 299-91	41, 65	91-700 859-15	16, 22
91-266 057-05	32, 46	91-266 202-71/951	19			91-700 889-15	16, 22
91-266 058-05	32, 46	91-266 210-71/851	33			91-700 785-15	14
91-266 086-71/895	37	91-266 211-71/851	47			91-701 515-15	48
91-266 090-12	36	91-266 213-71/895	26			95-617 317-15	65
91-266 092-75/895	37					95-780 087-75/895	66
91-266 093-05	37					96-700 216-15	29
						96-730 002-05	14
						97-30 117-325/893	68
						99-069 713-01	25, 29

No.	Seite Page Pages Página	No.	Seite Page Pages Página	No.	Seite Page Pages Página	No.	Seite Page Pages Página
99-115 034-15	69	99-136 480-91	53, 58	26 536-3.040-9	38		
99-115 037-45	69	99-136 481-91	30, 54				
99-115 411-91	63	99-136 482-91	54, 57				
99-115 425-91	30, 52, 53, 54, 57, 58	99-136 486-91	61				
99-133 124-91	65	99-136 489-91	63				
99-133 125-91	65	99-136 558-91	63				
99-133 283-15	22	99-136 559-91	63				
99-133 753-91	30, 52, 53, 54, 57, 58, 65	99-136 560-91	63				
99-134 206-05	70	99-136 675-91	63				
99-134 255-91	70	99-136 676-91	63				
99-134 256-91	30, 54, 55, 56	99-136 677-05	63				
99-134 299-91	65	99-136 678-05	63				
99-134 621-01	65	99-136 680-91	63				
99-135 001-95	55, 56	99-136 707-91	30, 54, 57				
99-135 002-95	65	99-136 757-05	68				
99-135 029-91	52	99-136 771-15	68				
99-135 490-91	57	280-1-120 122	72				
99-135 547-91	65	280-1-120 144	72				
99-135 789-95	68	280-1-120 205	72				
99-135 835-05	53, 58	280-1-120 243	72				
99-135 884-01	29	280-1-120 247	72				
99-135 890-91	28	25 135-8.002-7	65				
99-135 891-91	53	25 161-8.014-9	24				
99-135 911-91	65	25 308-8.203-0	30, 52, 53, 54, 55, 56, 57, 58, 59, 61, 62, 65				
99-136 071-95	55, 56	25 308-8.204-0	30, 53, 54, 58, 62, 63, 65, 70				
99-136 080-01	27	25 308-8.206-0	63, 68				
99-136 089-01	29	25 308-8.206-4	70				
99-136 235-91	57	26 536-3.020-9	24				
99-136 310-05	70	26 536-3.030-9	18, 19, 20, 21, 32, 33, 38, 42, 43, 44, 45, 46, 47				
99-136 328-91	59						
99-136 330-91	55, 56						
99-136 409-91	62						

PFAFF