

T027-T028 PARTS LIST

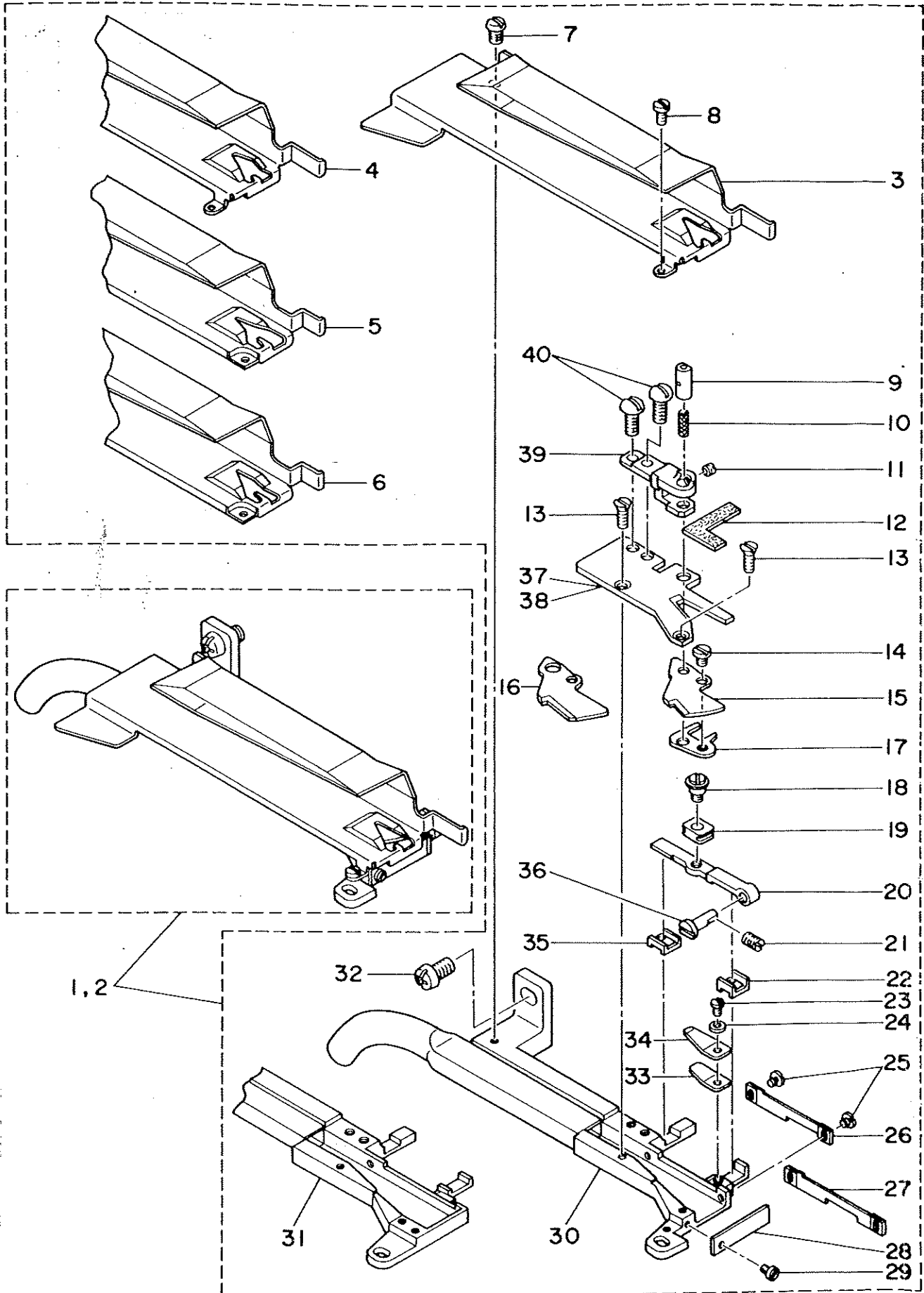

Ref No.
1
2
3
4
5
6
7
8
9
10
11
12
13
14
15
16
17
18
19
20
21
22
23
24
25
26
27
28
29
30
31
32
33
34
35
36
37
38
39
40

Ref. No.	Note	Part No. 品番	Description	E.C. 変更年月	品名	Amt. Req. 数量
1	#01	MAT-028000A0	T028 FLAT CUTTER ASM.		T028 フラットカッター クミ	1
2	#02	MAT-027000A0	T027 FLAT CUTTER ASM.		T027 フラットカッター クミ	1
3	#01	MAT-02807000	KNIFE BASE COVER, WIDE		メスタイ カハ (ワ)	(1)
4	#01	MAT-02806000	KNIFE BASE COVER, NARROW		メスタイ カハ (ホ)	(1)
5	#02	MAT-02702000	KNIFE BASE COVER, WIDE		メスタイ カハ (ワ)	(1)
6	#02	MAT-02701000	KNIFE BASE COVER, NARROW		メスタイ カハ (ホ)	(1)
7		SS-4090610-SP	SCREW 9/64-40 L=6		ナメシ 9/64-40 L=9	(1)
8		SS-7060310-SP	SCREW 3/32-56 L=3		ナメシ 3/32-56 L=3	(1)
9		MAT-02411000	MOVABLE BLADE STUD		トウメシ	(1)
10		CQ-2520000-00	OIL WICK		シソ	(0.1)
11		SS-8080310-TP	SCREW 1/8-44 L=2.8		トメシ 1/8-44 L=2.8	(1)
12		MAT-02415000	FELT		フェルト	(1)
13		SS-1060610-SP	SCREW 3/32-56 L=5.5		ナメシ 3/32-56 L=5.5	(2)
14		SS-6080340-SP	SCREW 1/8-44 L=3.0		ナメシ 1/8-44 L=2.9	(1)
15	#01	MAT-02802000	MOVING KNIFE		トウメス	(1)
16	#02	MAT-02402000	MOVABLE BLADE		トウメス	(1)
17		MAT-02408000	KNIFE DRIVING BASE		メスタウメシ	(1)
18		MAT-02406000	HINGE SCREW		クワウリク カイト	(1)
19		MAT-02412000	SLIDE BLOCK		メスタウ カク	(1)
20		MAT-02404000	DRIVING LINK		クワウリク	(1)
21		SS-8080610-SP	SCREW 1/8-44 L=5.5		トメシ 1/8-44 L=5.5	(1)
22		MAT-02409000	DRIVING LINK GUIDE (A)		クワウリク カイト A	(1)
23		SS-4060310-SP	SCREW 3/32-56 L=2.5		ナメシ 3/32-56 L=2.5	(1)
24		WP-0250516-SD	WASHER 2.5X6X0.5		ナメシ 2.5X6X0.5	(1)
25		SS-6060220-SP	SCREW 3/32-56 L= 2.0		ナメシ 3/32-56 L=2	(2)
26	#01	MAT-028050A0	AIR STOP PLATE ASM.		エアストップ (ワ)	(1)
27	#02	MAT-024190A0	AIR STOP PLATE ASM.		エアストップ クミ	(1)
28	#01	MAT-02804000	COVER PLATE		ベツタン カハ	(1)
29	#01	SS-6060220-SP	SCREW 3/32-56 L= 2.0		ナメシ 3/32-56 L=2	(1)
30	#01	MAT-028010A0	KNIFE MOUNTING BASE ASM.		メスタイ クミ	(1)
31	#02	MAT-024010A0	KNIFE MOUNTING BASE ASM.		メスタイ クミ	(1)
32		SS-4120915-SP	SCREW 12/64-28 L=9		ナメシ 3/16-28 L=9	(1)
33		MAT-02414000	SPRING (B)		トウメス スプリング B	(1)
34		MAT-02413000	SPRING (A)		トウメス スプリング A	(1)
35		MAT-02410000	DRIVING LINK GUIDE (B)		クワウリク カイト B	(1)
36		MAT-02405000	PIN		クワウリク ピン	(1)
37	#01	MAT-02803000	FIXED KNIFE		コテ メス	(1)
38	#02	MAT-02403000	FIXED BLADE		コテ メス	(1)
39		MAT-02407000	BEARING		シワウケ	(1)
40		SS-3090810-SL	SCREW 9/64-40 L=8		ナメシ 9/64-40 L=8	(2)

Note(注記)#01.....For T028
#02.....For T027

T028用
T027用

JUKI CORPORATION

JUKI 株式会社

1988. 4 Printed in Japan