

## 1183-712/02

Teileliste

Parts list

Lista de piezas

零件表

Diese Teileliste hat für Maschinen ab nachfolgender  
Seriennummer Gültigkeit:

This parts list applies to machines from the following  
serial numbers onwards:

Esta lista de piezas tiene validez para máquinas a partir del  
número de serie siguiente:

本零件表对从下列系列号起的机器有效:

# 6001000 →

Alle Informationen und Abbildungen waren zum Zeitpunkt der Druckgebung auf dem neusten Stand.

Technische Änderungen vorbehalten!

Der Nachdruck, die Vervielfältigung sowie die Übersetzung - auch auszugsweise - aus PFAFF-Teilelisten ist nur mit unserer vorherigen Zustimmung und mit der Quellenangabe gestattet.

At the time of printing, all information and illustrations contained in this document were up to date.

Subject to alteration!

The reprinting, copying or translation of PFAFF Parts lists whether in whole or in part, is only permitted with our previous permission and with written reference to the source.

Todas las informaciones e ilustraciones de este manual estaban al día en el momento de entregarse para su impresión.

¡ Salvo modificaciones técnicas!

La reimpresión, reproducción y traducción - aunque sólo sea parcial - de las listas de piezas PFAFF sólo está permitida con nuestro permiso previo e indicando la fuente.

所有信息和图片在付印时都是最新的。

保留技术更改的权力！

全部或部分翻印、复制以及翻译PFAFF-零件表必须事先经由我们同意并且注明来源。

## **PFAFF Industrie Maschinen AG**

Postfach 3020

D-67653 Kaiserslautern

Königstr. 154

D-67655 Kaiserslautern

	<b>Seite</b> Page Página 页号
<b>0</b> <b>Wichtiger Hinweis</b> .....	<b>0 - 1</b>
Important note	
Observación importante	
重要提示	
<b>1</b> <b>Vorwort</b> .....	<b>1 - 1</b>
Foreword	
Notas preliminares	
前言	
<b>2</b> <b>Erläuterungen der Schlüsselzeichen</b> .....	<b>2 - 1</b>
Explanation of key markings	
Explicaciones de los signos clave	
标记说明	
<b>3</b> <b>Basismaschine</b>	
Basic machine	
Máquina básicas	
基础机器	
<b>3.01</b> <b>Gehäuseteile</b> .....	<b>3 - 1</b>
Housing sections	
Piezas del cárter	
机身零件	
<b>3.02</b> <b>Kopfteile</b> .....	<b>3 - 2</b>
Needle head parts	
Piezas de la cabeza	
机头零件	
<b>3.03</b> <b>Armteile</b> .....	<b>3 - 5</b>
Arm parts	
Piezas del brazo	
机臂零件	
<b>3.04</b> <b>Grundplattenteile</b> .....	<b>3 - 8</b>
Bedplate parts	
Piezas del cárter	
底板零件	
<b>4</b> <b>Elektrische Ausrüstung</b>	
Electrical equipment	
Equipo eléctrico	
电设备	

	Seite Page Página 页号
4.01 Kabelbaum zum Oberteil..... Cable tree to sewing head Mazo de cables para el cabezal 上部机器电缆束	4 - 1
4.02 Bedienfeld ..... Control panel Panel de mandos 操作板	4 - 2
4.03 Einbaumotor ..... Built-in motor Motor incorporado 内装式电机	4 - 3
4.04 Oberteilerkennung und Einschaltsperr..... Sewing head identification and start inhibitor Detección de la parte superior y bloqueo de arranque 上部机器识别和起动机闭锁	4 - 4
4.05 Sollwertgeber ..... Set-point generator Emisor del valor teórico 给定值发生器	4 - 5
4.06 Motor-Hauptschalter ..... Main switch Interruptor principal 电机主开关	4 - 6
4.07 Steuerkasten ..... Control box Caja de mandos 控制箱	4 - 7
5 Garnrollenständer ..... Reel stands Portacarretes 线轴支架	5 - 1
6 Einstellehren ..... Adjustment gauges Calibres de ajuste 设置量规	6 - 1

	<b>Seite</b> Page Página 页号
<b>7</b> Teile zur Tischplatte ..... Parts for table top Piezas para el tablero 用于台板的零件	<b>6 - 1</b>
<b>8</b> Schmiermittel-Übersicht ..... Overview of lubricants Tabla de lubricantes 润滑剂一览	<b>8 - 1</b>
<b>9</b> Index (Teilenummern / Seitenzahlen) ..... Index (part numbers / page numbers) Index (números de pieza / números de página) 注脚(零件号/页号)	<b>9 - 1</b>

### Achtung!



Wir machen ausdrücklich darauf aufmerksam, daß Ersatz- und Zubehörteile, die nicht von uns geliefert werden, auch nicht von uns geprüft und freigegeben sind. Der Einbau und / oder die Verwendung solcher Produkte kann daher u. Umständen konstruktiv vorgegebene Eigenschaften Ihrer Maschine negativ verändern. Für Schäden, die durch die Verwendung von Nicht-Originalteilen entstehen, übernehmen wir keine Haftung!

### Caution!



We warn you expressively that spare parts and accessories that are not supplied by us are not tested and released by us. Fitting or using these products may therefore have negative influences on features that depend on the machine design. We are not liable for any damage caused by the use of non-Pfaff parts!

### ¡Atención!















Se hace observar que en el caso de piezas de recambio y accesorios que no hayan sido suministrados por nosotros, quiere decir que non han sido sometidas por nuestra parte a un control y que no se les ha dado el visto bueno. Por esta razón, el montaje y/o empleo de tales productos puede repercutir negativamente en las características previstas en su máquina. ¡Para los daños que eventualmente pudiesen presentarse al utilizar piezas no originales, no asumimos ninguna garantía!

### 注意!



我们必须明确指出，所有不是由我们供货的备件和附件都未经我们检查，也没有被我们批准使用。装入和/或使用这些产品可能在一定的情况下会对机器的设计特性造成负面改变。对由于使用非原装件所造成的损失，我们不负任何责任！

- Die Seriennummer der Maschine, für die diese Teileliste Gültigkeit hat, ist auf der Titelseite aufgeführt.
  - Alle Teile sind so abgebildet, wie sie in der Maschine funktionsmäßig zusammengehören.
  - Gestrichelt dargestellte Teile zeigen angrenzende Teile aus anderen Funktionsgruppen.
  - Im oberen Teil der Bildseiten befindet sich eine Gesamtansicht der Maschine .
  - Der Einbauort der dargestellten Teile wird durch eine gerasterte Fläche gekennzeichnet.
  - Einrahmungen auf den Bildseiten zeigen, aus welchen Einzelteilen sich die Gruppenteile zusammensetzen.
  - Die auf den Bildseiten verwendeten Schlüsselzeichen (  ;  ;  usw.) sind im Kapitel "Erläuterungen der Schlüsselzeichen" aufgelistet.
- 
- The serial number of the machine to which this parts list applies is indicated on the cover page.
  - All parts are illustrated in function groups with the parts which they function together with in the machine.
  - Parts illustrated with broken lines are parts from other function groups which border on the illustrated function group.
  - The above section of the page of illustrations contains a total view of the machine. The place for the installation of the parts pictured here is marked by the grid.
  - The framed-in sections on the illustration pages show the individual parts comprising a group.
  - The key markings used on the illustrated pages (  ;  ;  etc.) are listed in the chapter "Explanation of key markings".
- 
- El número de serie de la máquina para la cual tiene validez esta lista de piezas va indicado en la página de título.
  - Todas las piezas están ilustradas tal como aparecen en la máquina para su funcionamiento.
  - Las piezas representadas con rayitas muestran piezas colindantes de otros grupos de funciones.
  - En la parte superior de las páginas ilustradas se puede ver una vista en conjunto de la máquina.
  - El lugar de montaje de la pieza representada va caracterizada mediante una superficie reticulada.
  - Los recuadros en las páginas ilustradas indican las piezas individuales de que se componen los grupos.
  - Los signos clave (  ;  ;  etc.) empleados en las páginas con ilustraciones van listados en el capítulo "Explicaciones de los signos clave".
- 
- 适用于本零件表的机器系列号列在首页上。
  - 所有的零件都按照其在机器中的功能情况合在一起表达。
  - 用虚线表示的零件为相邻功能组中的零件。
  - 图的上部为机器全景。
  - 所示零件的安装部位用影格面表示。
  - 页上的框表示这套组件都由哪些零件所组成。
  - 图页上所使用的标记 (  ;  ;  等) 列表在“标记说明”中。

- 3/4**      **Selbstklebend**  
Self-adhesive  
Autoadhesivo  
自粘的
- 6**      **Nadeldicke und Spitzenform bei Bestellung angeben.**  
Needle size and style of point to be stated on order.  
Grosor de aguja y forma de la punta, indíquese en los pedidos.  
在订货时给出针厚和针尖型式。
- 27/5**      **Eingeklammerte Zahl = Länge in mm.**  
Number in brackets = length in mm.  
Cifra entre paréntesis = largura en mm.  
被括起的数字=长度，单位mm。
- 40/3**      **Fetten mit 28-011 202-47; Bestellnummer siehe Seite 8 - 1.**  
Grease with 28-011 202-47; for part number see page 8 - 1.  
Engrase con grasa 28-011 202-47; para el número de pedido véase la página 8 - 1.  
上脂用 28-011 202-47; 订货号见 8 - 1.页。
- 40/13**      **Fetten mit 28-011 202-05; Bestellnummer siehe Seite 8 - 1.**  
Grease with 28-011 202-05; for part number see page 8 - 1.  
Engrase con grasa 28-011 202-05; para el número de pedido véase la página 8 - 1.  
上脂用 28-011 202-05; 订货号见 8 - 1.页。
- 40/17**      **Fetten mit 28-011 202-70; Bestellnummer siehe Seite 8 - 1.**  
Grease with 28-011 202-70; for part number see page 8 - 1.  
Engrase con grasa 28-011 202-70; para el número de pedido véase la página 8 - 1.  
上脂用 28-011 202-70; 订货号见 8 - 1.页。
- 40/26**      **Füllen mit 28-011 201-05; Bestellnummer siehe Seite 8 - 1.**  
Top up with 28-011 201-05; for part number see page 8 - 1.  
Rellene con 28-011 201-05; para el número de pedido véase la página 8 - 1.  
注油用 28-011 201-05; 订货号见 8 - 1.页。
- 40/27**      **Tränken mit 28-011 201-05; Bestellnummer siehe Seite 8 - 1**  
Grease with 28-011 201-05; for part number see page 8 - 1.  
Engrase con grasa 28-011 201-05; para el número de pedido véase la página 8 - 1.  
浸油用 28-011 201-05; 订货号见 8 - 1.页。
- 90/1**      **Für Wechselstrom**  
For single-phase A.C.  
Para corriente alterna monofásica  
适用于交流电



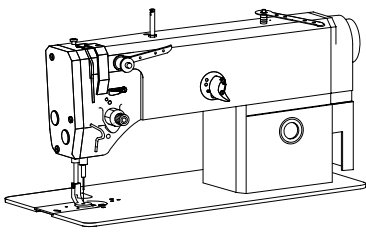

Gehäuseteile  
Housing sections  
Piezas del cárter  
机身零件

PFAFF 1183-712/02

3.01

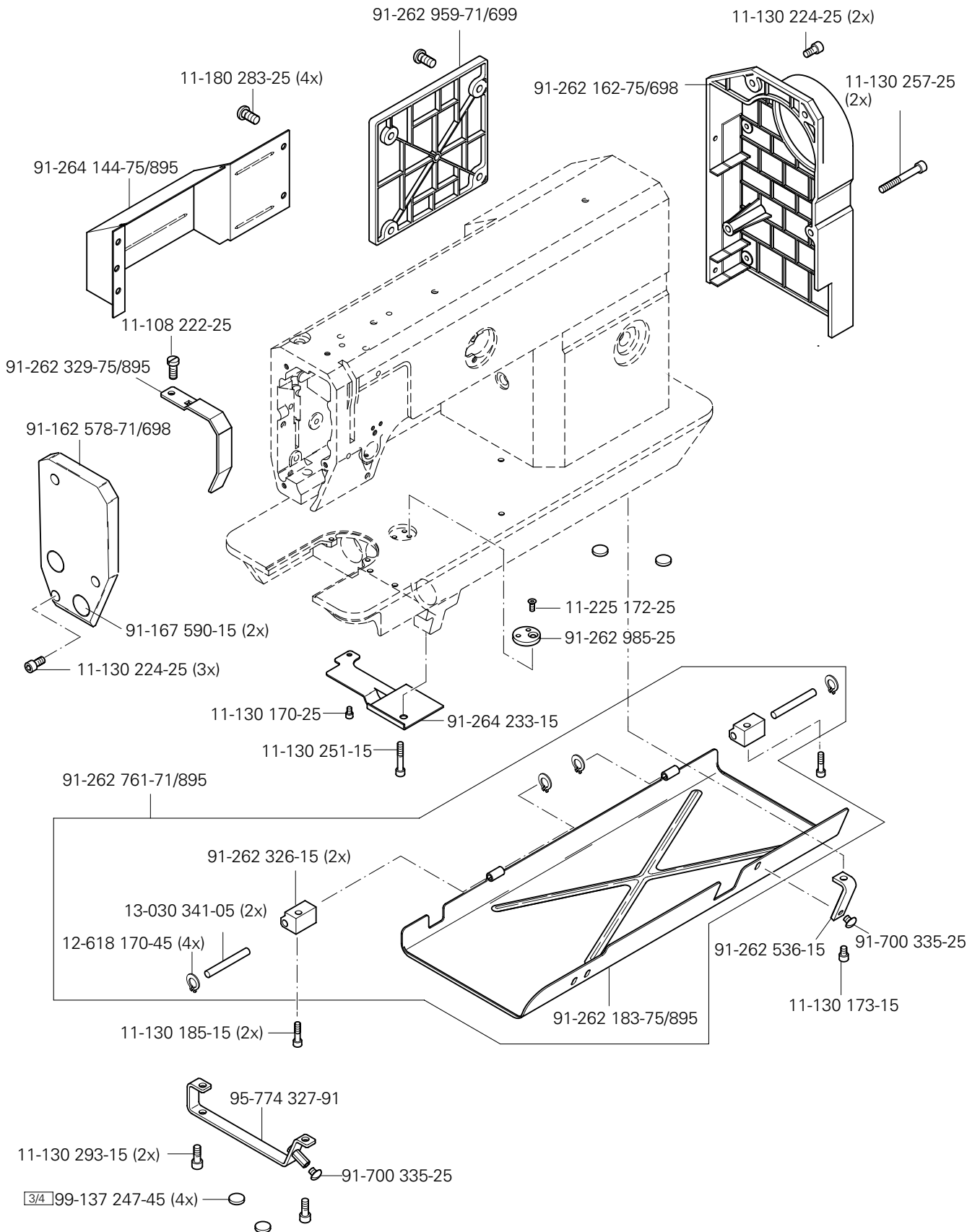

# 3.02

Kopfteile  
Needle head parts  
Piezas de la cabeza  
机头零件

PFAFF 1183-712/02

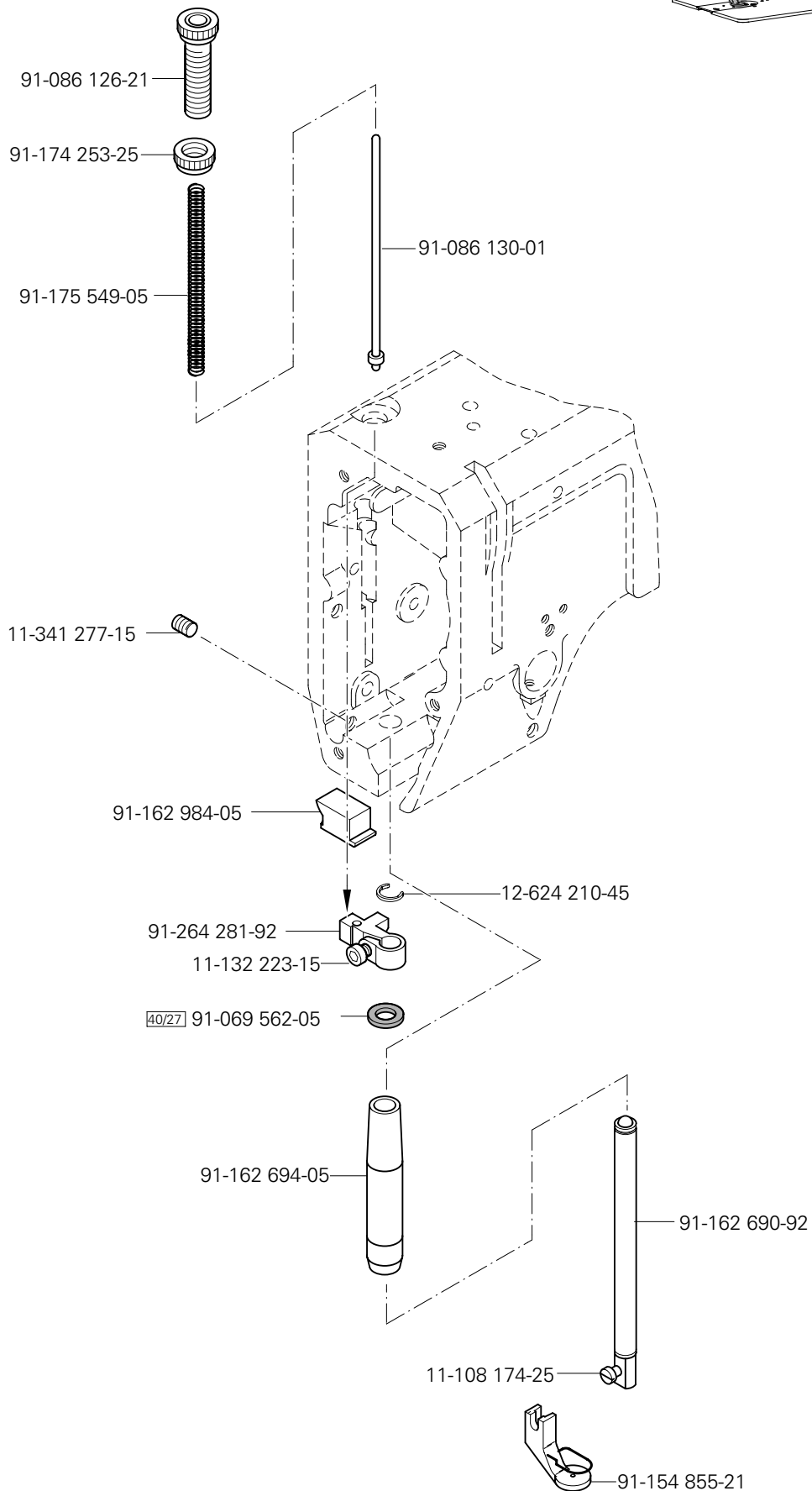
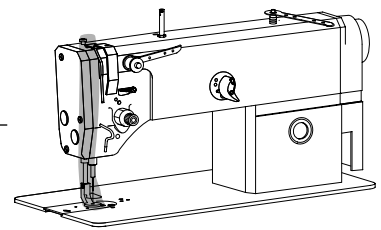

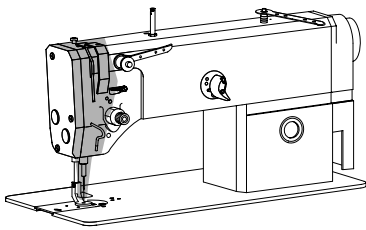

Kopfteile  
Needle head parts  
Piezas de la cabeza  
机头零件

PFAFF 1183-712/02

3.02

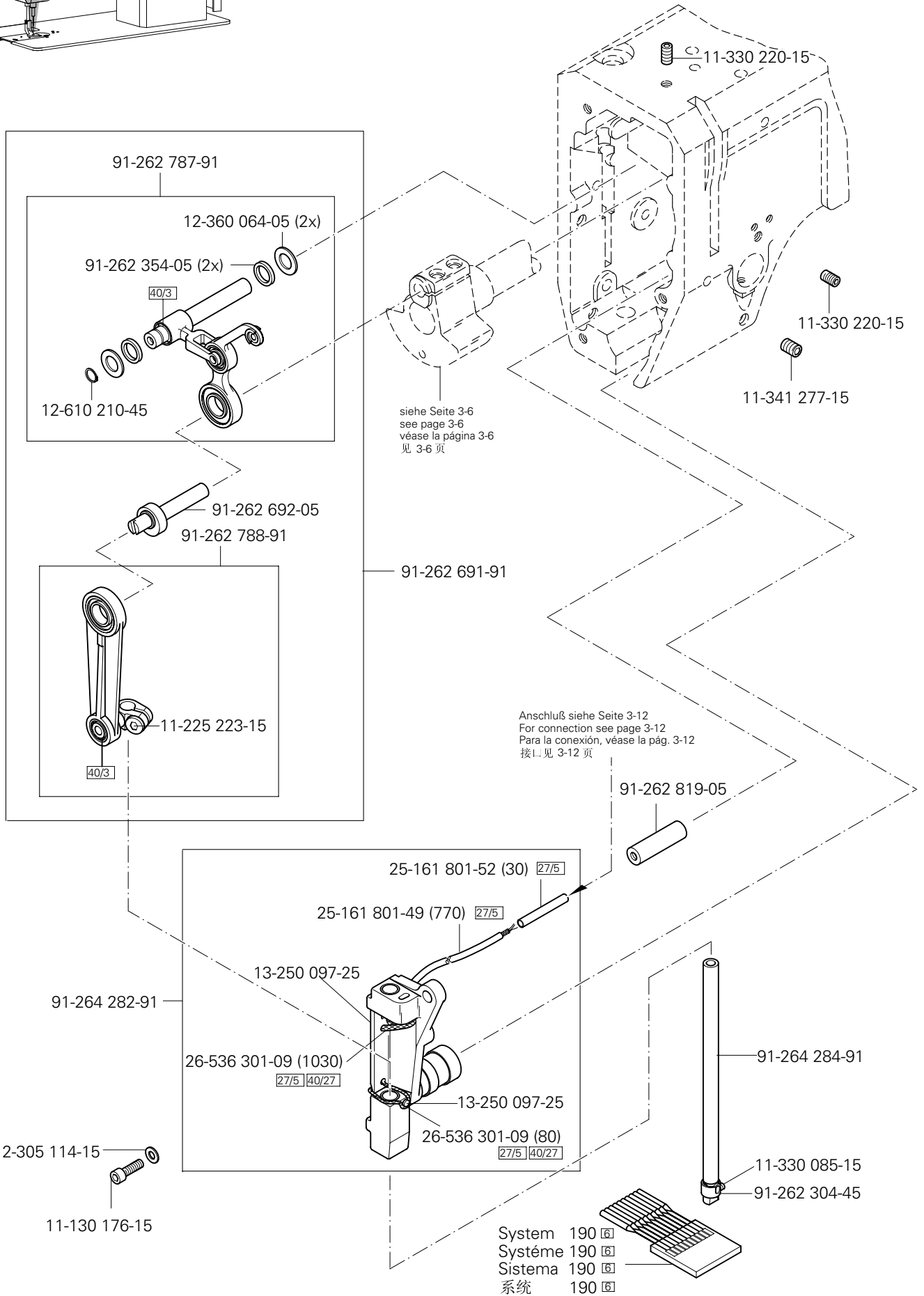

# 3.02

## Kopfteile Needle head parts Piezas de la cabeza 机头零件

PFAFF 1183-712/02

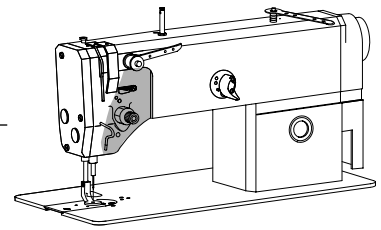

Anschluß siehe Seite 4-1  
For connection see page 4-1  
Para la conexión, véase la pág. 4-1  
接: 1 见 4-1 页

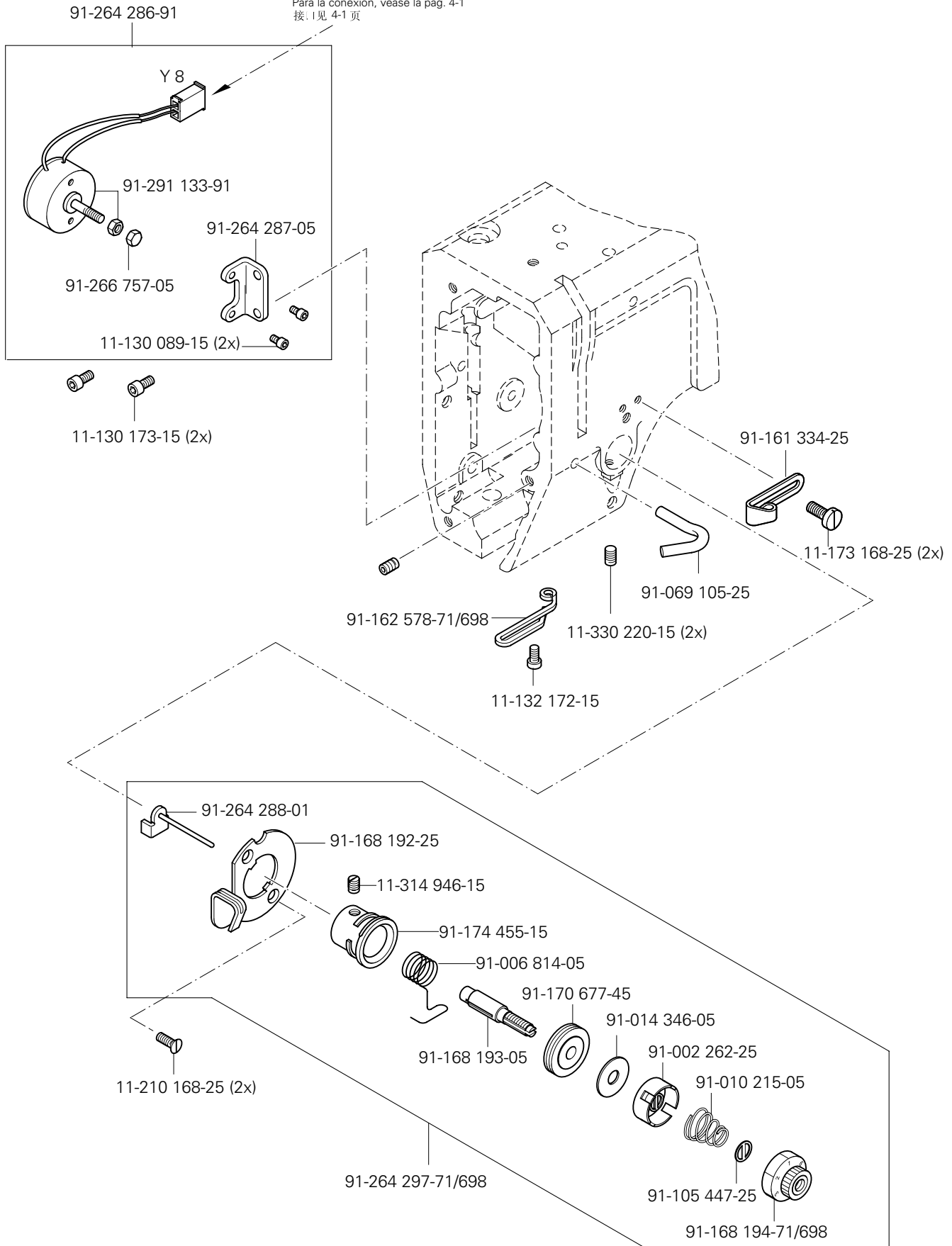

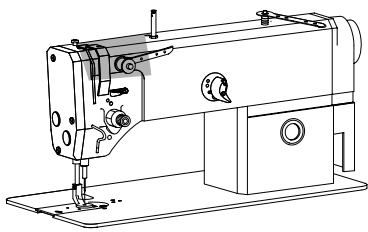

Armteile  
 Arm parts  
 Piezas del brazo  
 机臂零件

PFAFF 1183-712/02

3.03

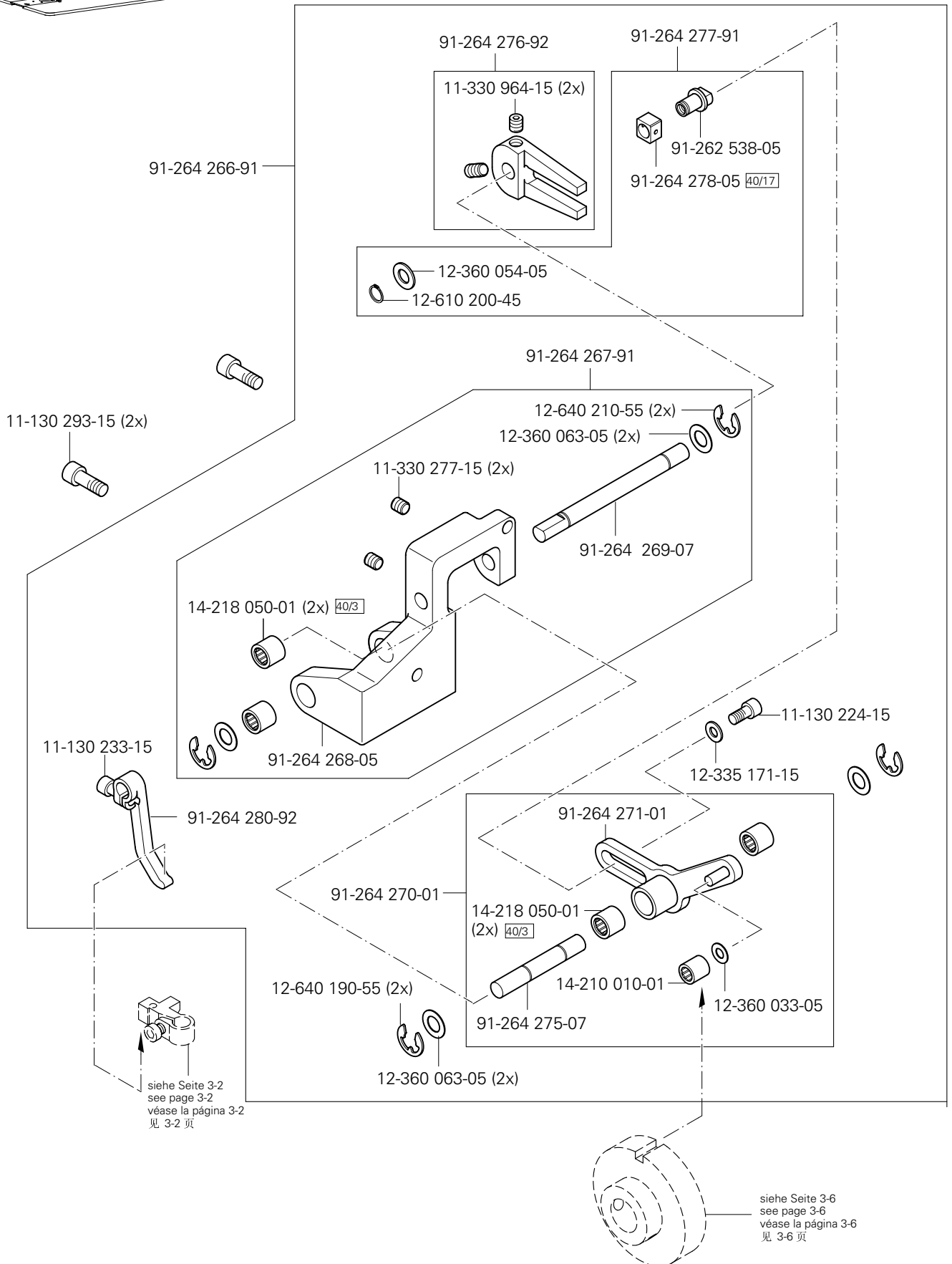

# 3.03

Armteile  
 Arm parts  
 Piezas del brazo  
 机臂零件

PFAFF 1183-712/02

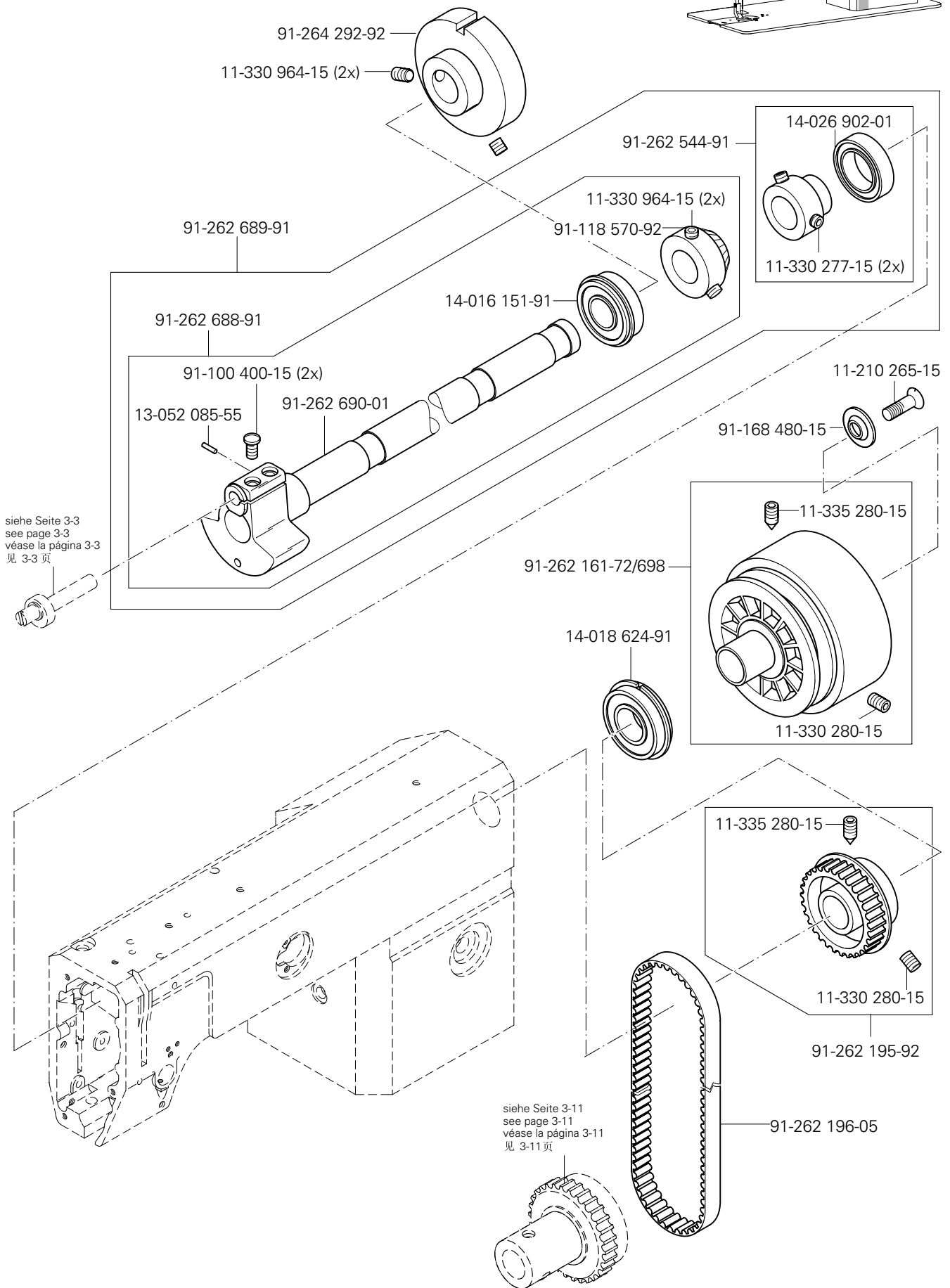
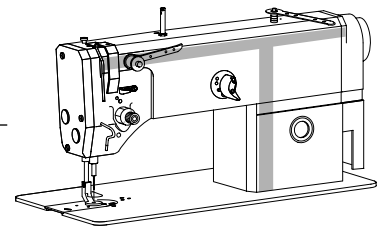

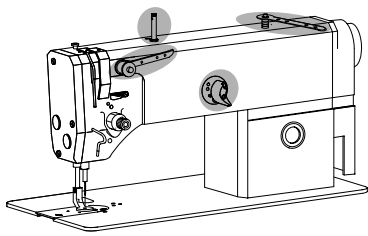

Armteile  
 Arm parts  
 Piezas del brazo  
 机臂零件

PFAFF 1183-712/02

3.03

91-056 578-91

91-069 585-25

12-024 191-15

11-330 175-15

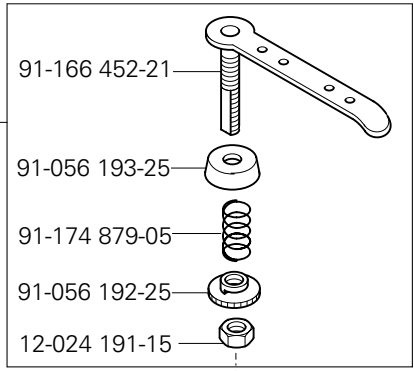

95-774 466-91

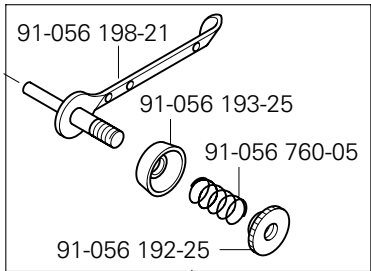
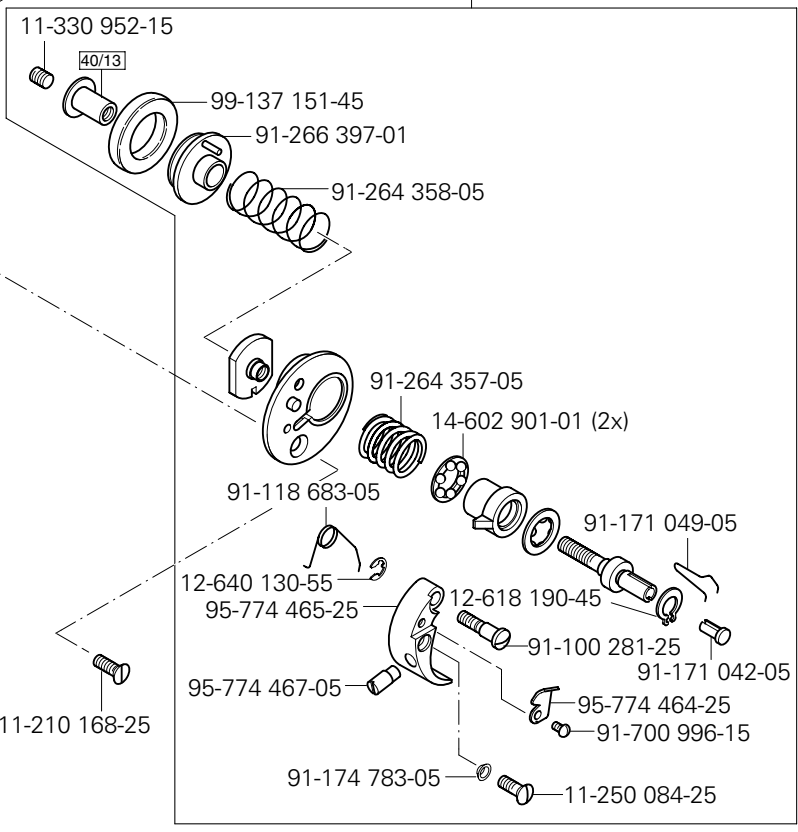

91-056 197-91

# 3.04

Grundplattenteile  
Bedplate parts  
Piezas del cárter  
底板零件

PFAFF 1183-712/02

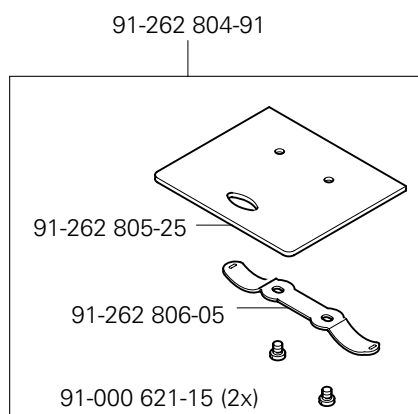
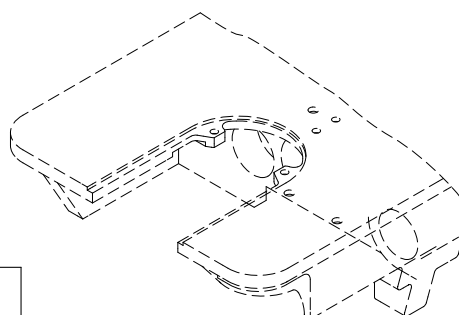
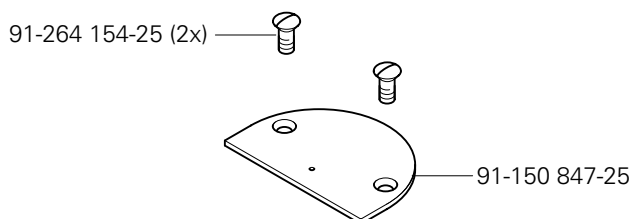
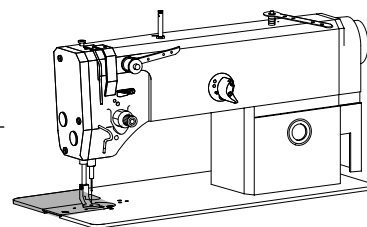



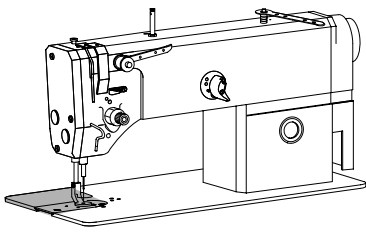

Grundplattenteile  
Bedplate parts  
Piezas del cárter  
底板零件

PFAFF 1183-712/02

3.04

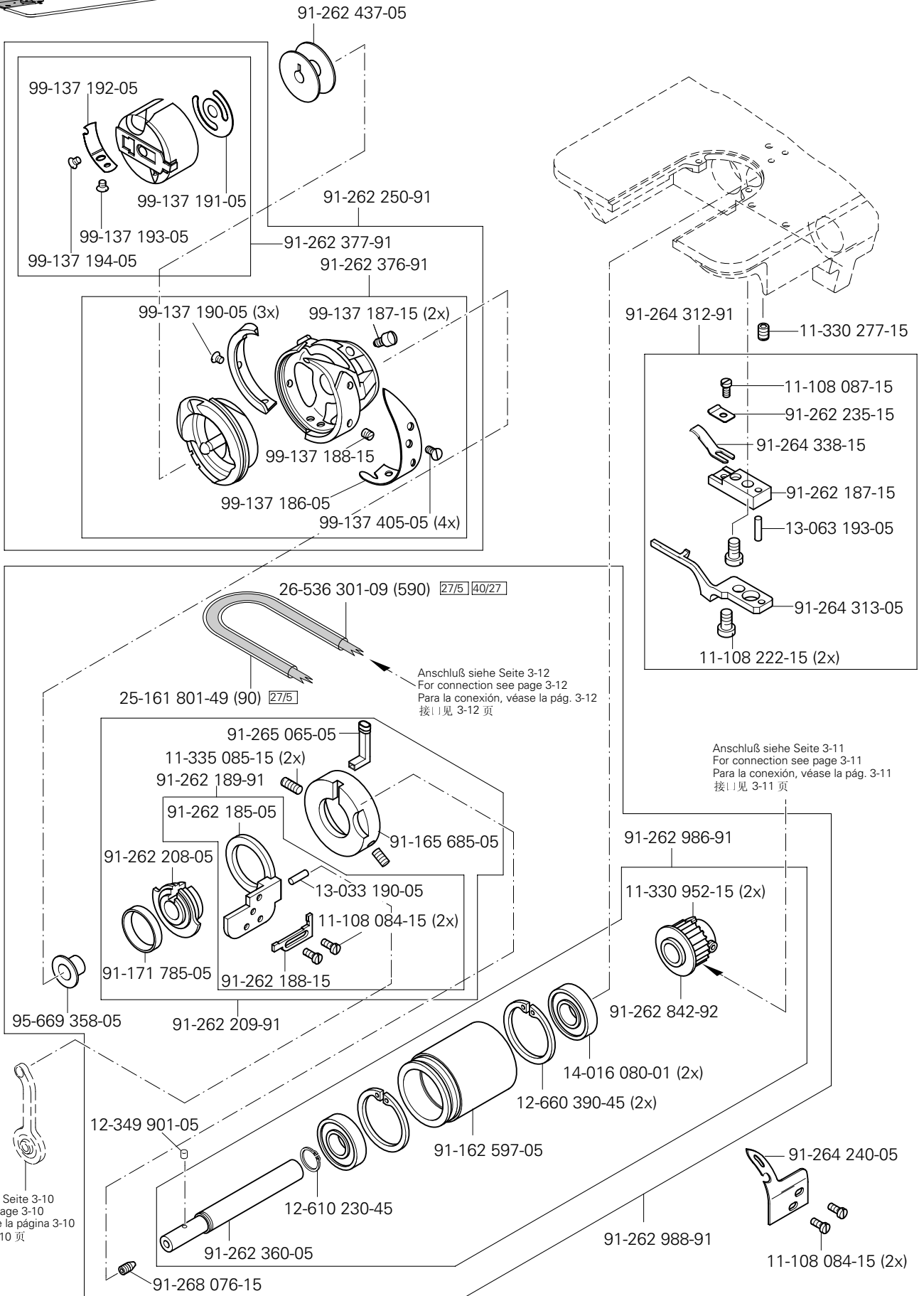

siehe Seite 3-10  
see page 3-10  
véase la página 3-10  
见 3-10 页

# 3.04

Grundplattenteile  
Bedplate parts  
Piezas del cárter  
底板零件

PFAFF 1183-712/02

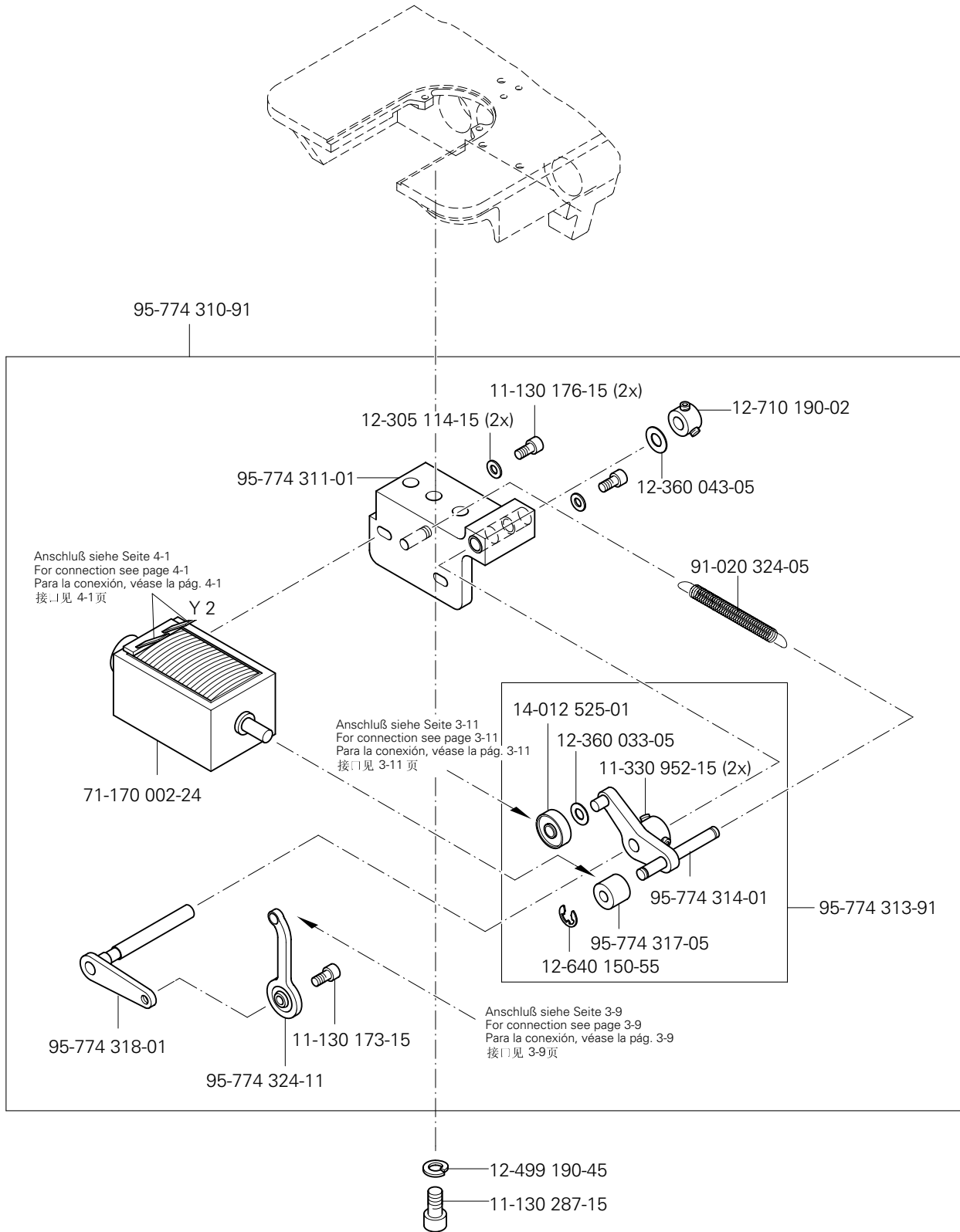
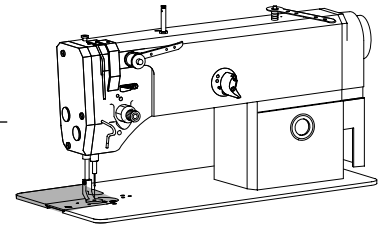

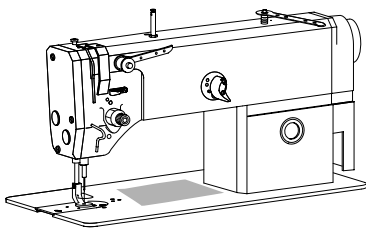

Grundplattenteile  
Bedplate parts  
Piezas del cárter  
底板零件

PFAFF 1183-712/02

3.04

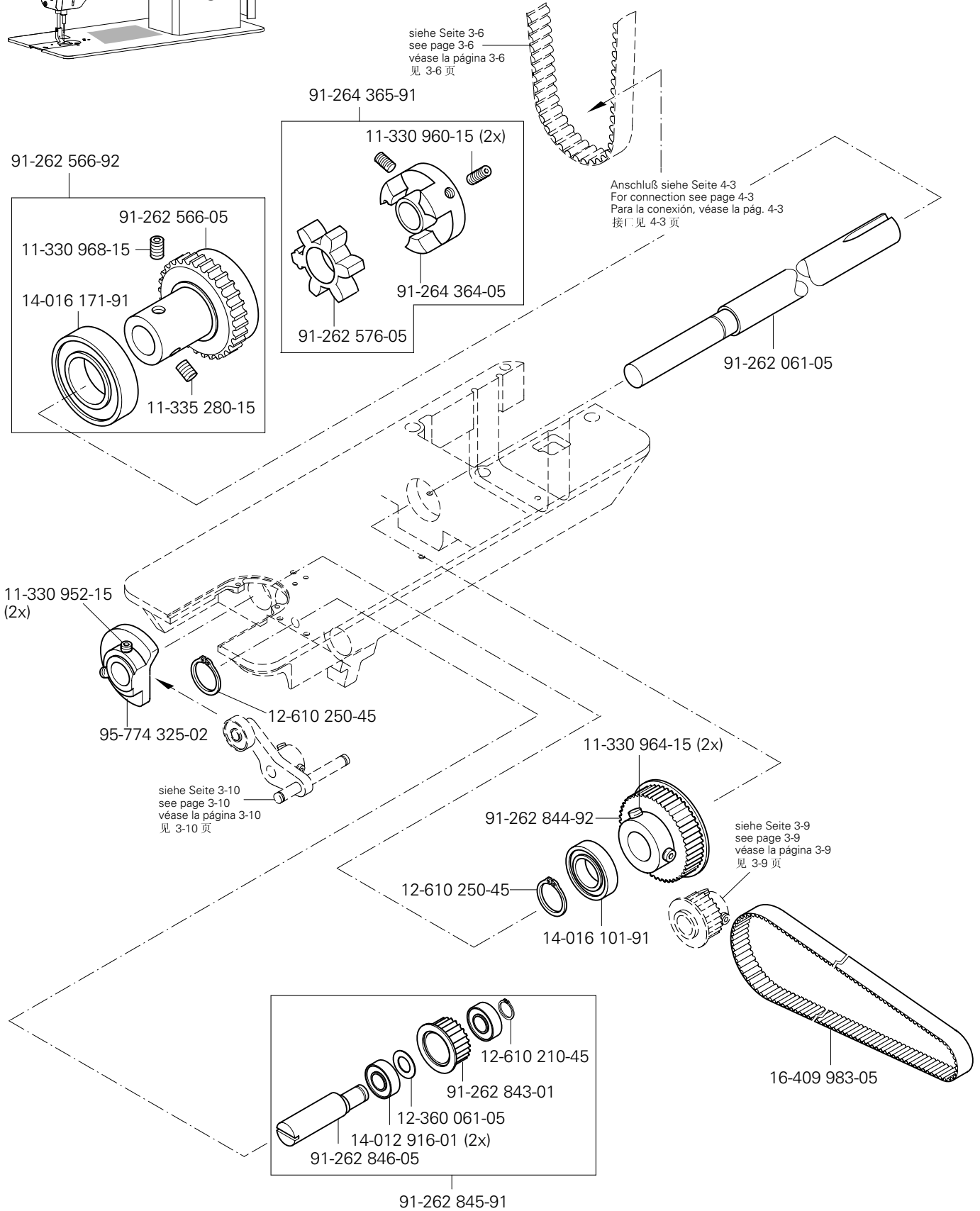

# 3.04

Grundplattenteile  
Bedplate parts  
Piezas del cárter  
底板零件

PFAFF 1183-712/02

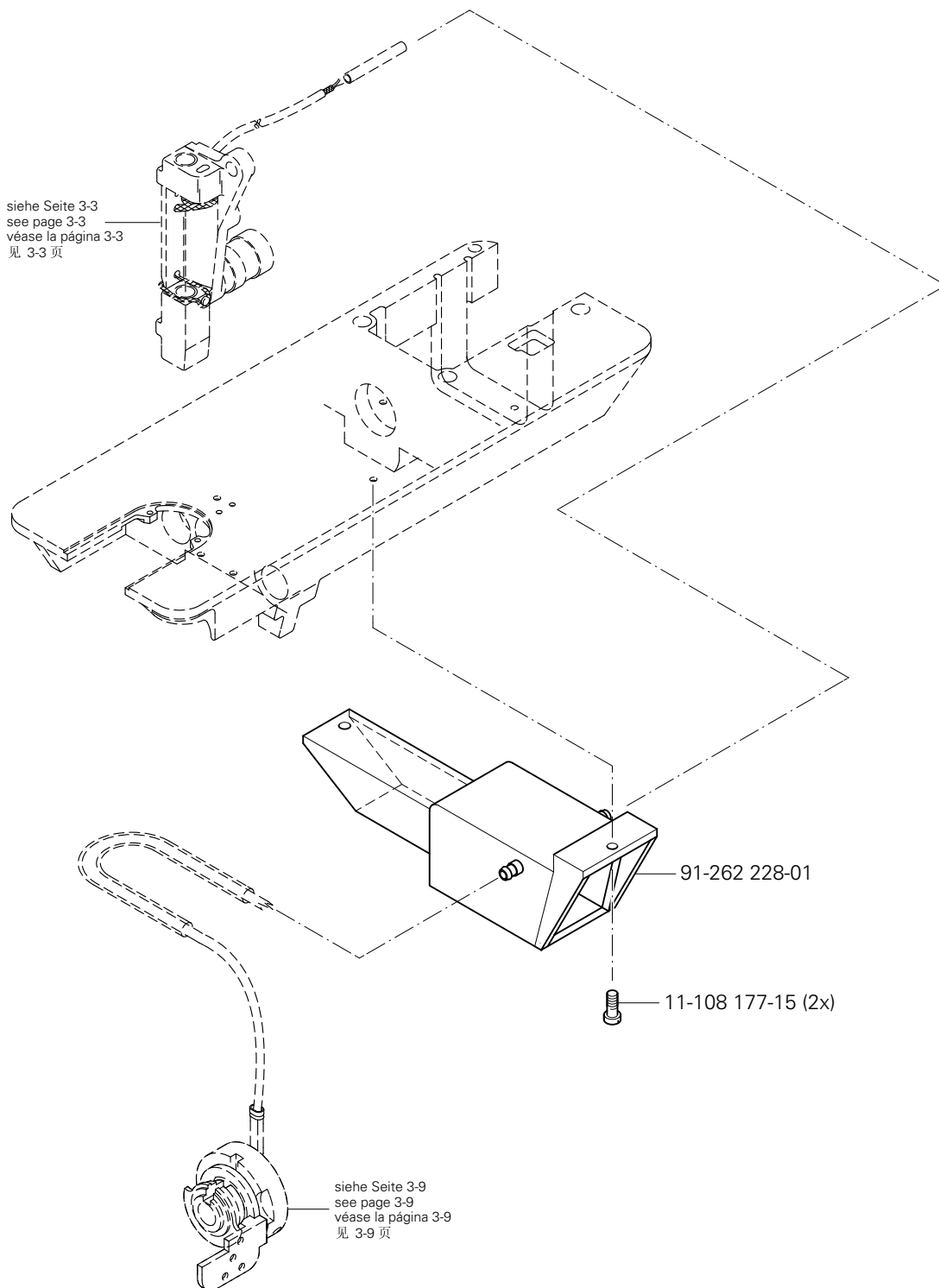
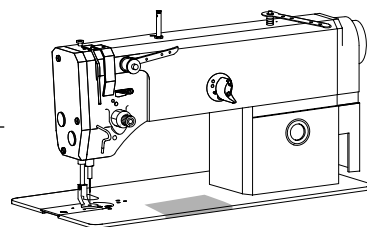

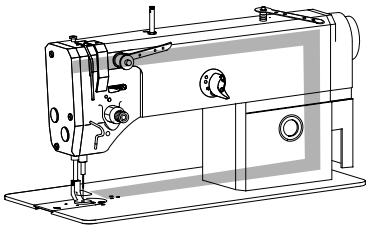

Kabelbaum zum Oberteil  
 Cable tree to sewing head  
 Mazo de cables para el cabezal  
 上部机器电缆束

PFAFF 1183-712/02

4.01

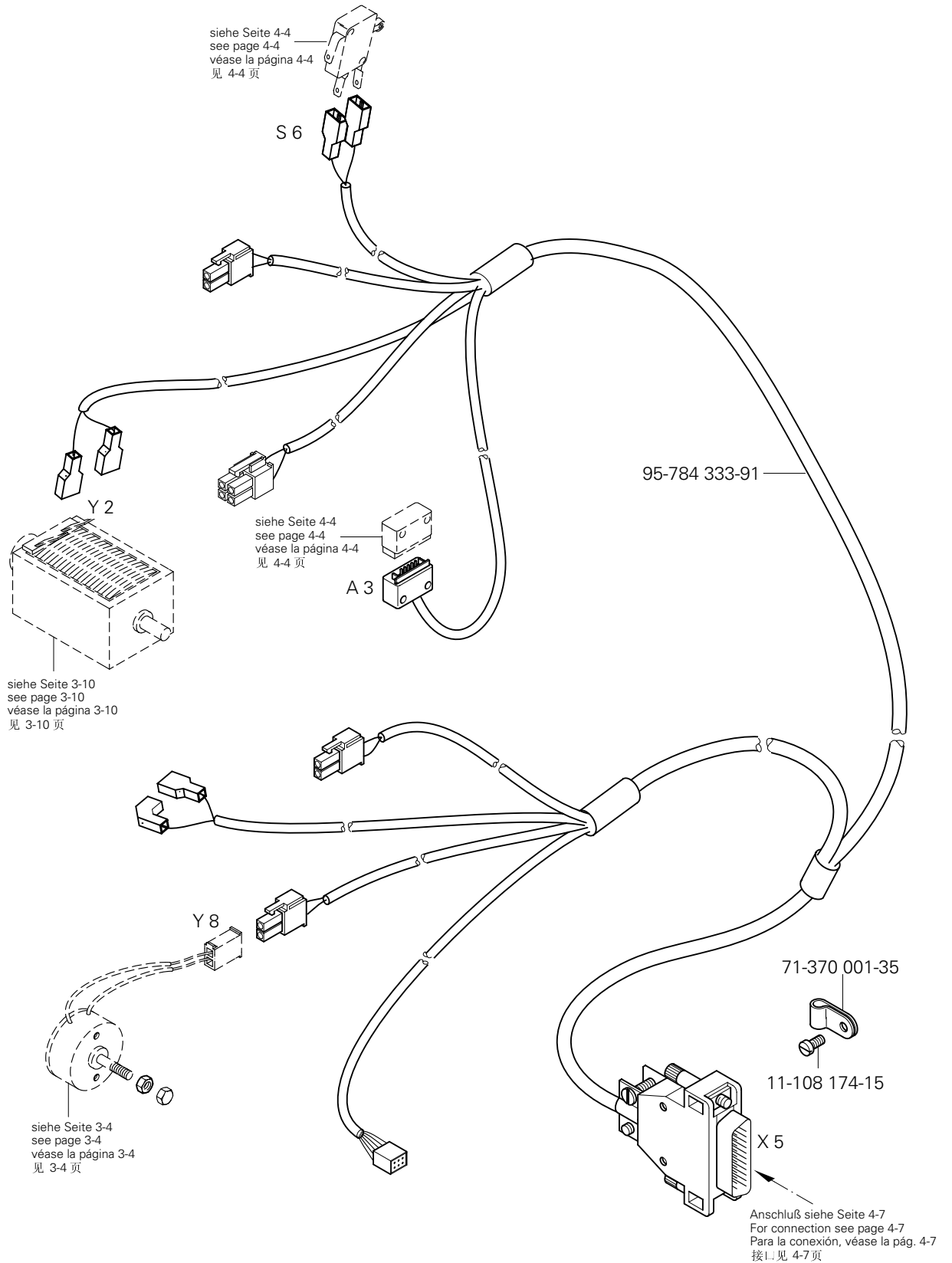

# 4.02

Bedienfeld  
Control panel  
Panel de mandos  
操作板

PFAFF 1183-712/02

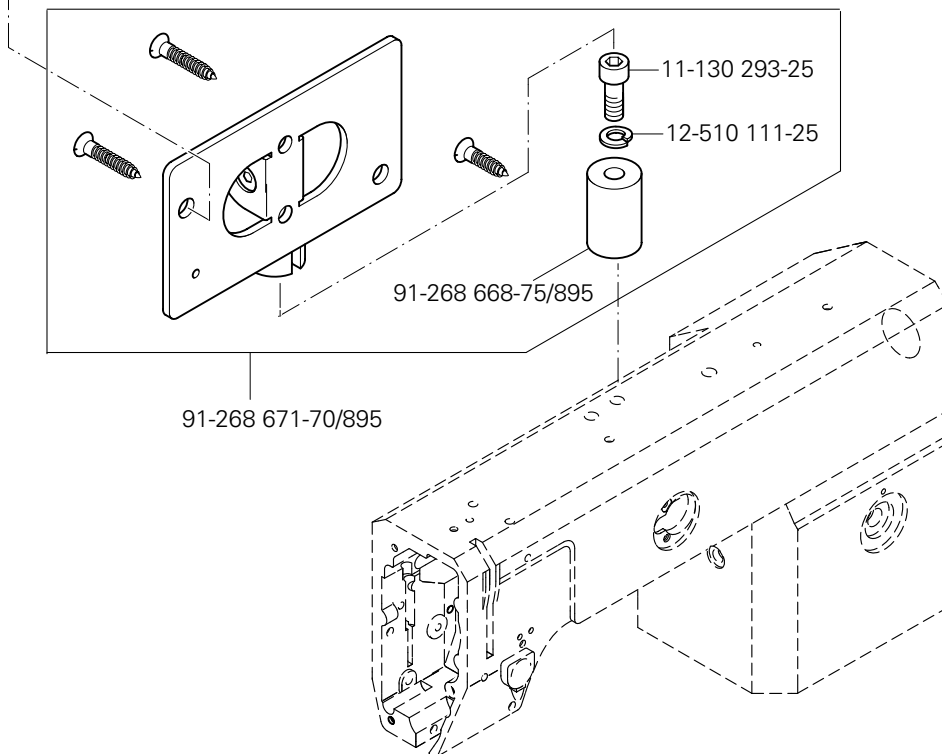
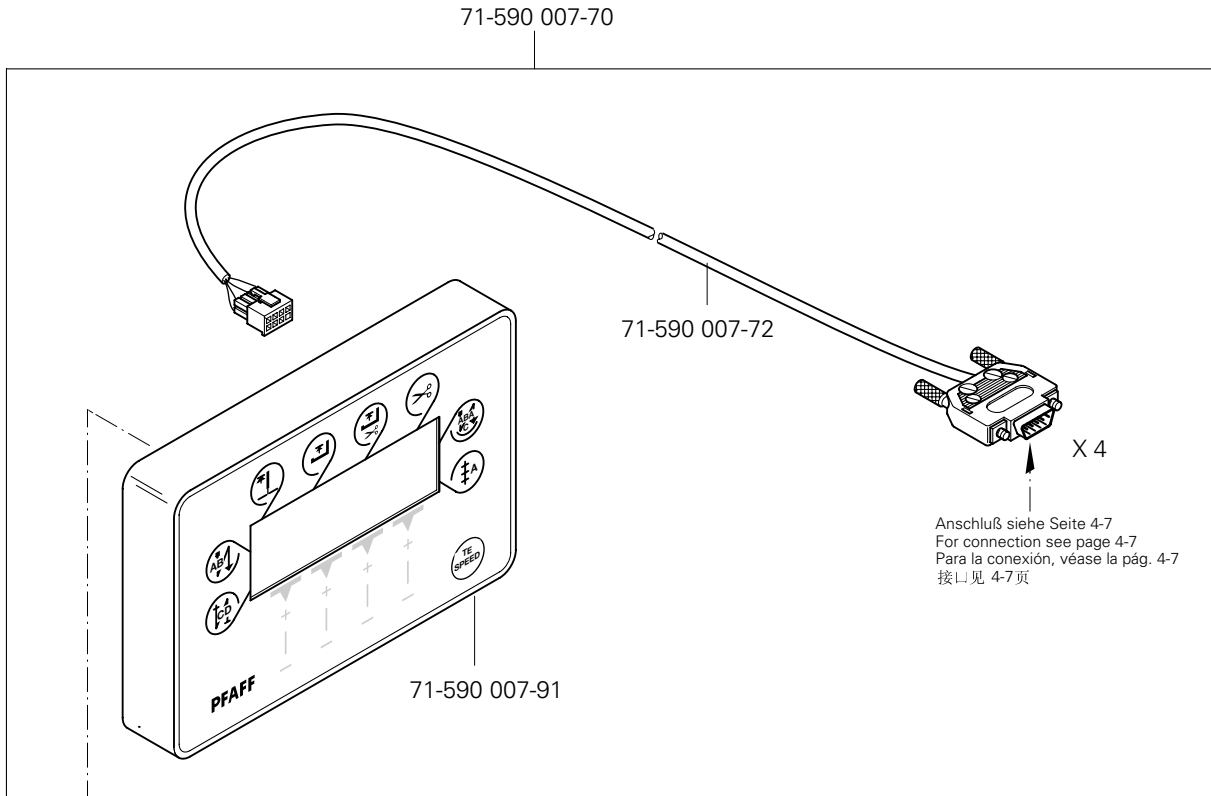
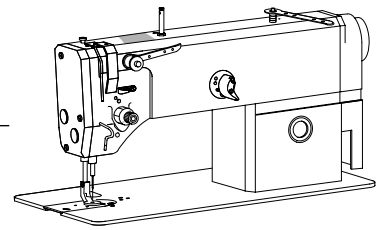

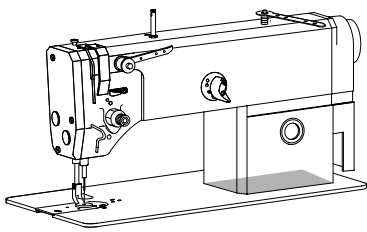

Einbaumotor  
Built-in motor  
Motor incorporado  
内装式电机

PFAFF 1183-712/02

4.03

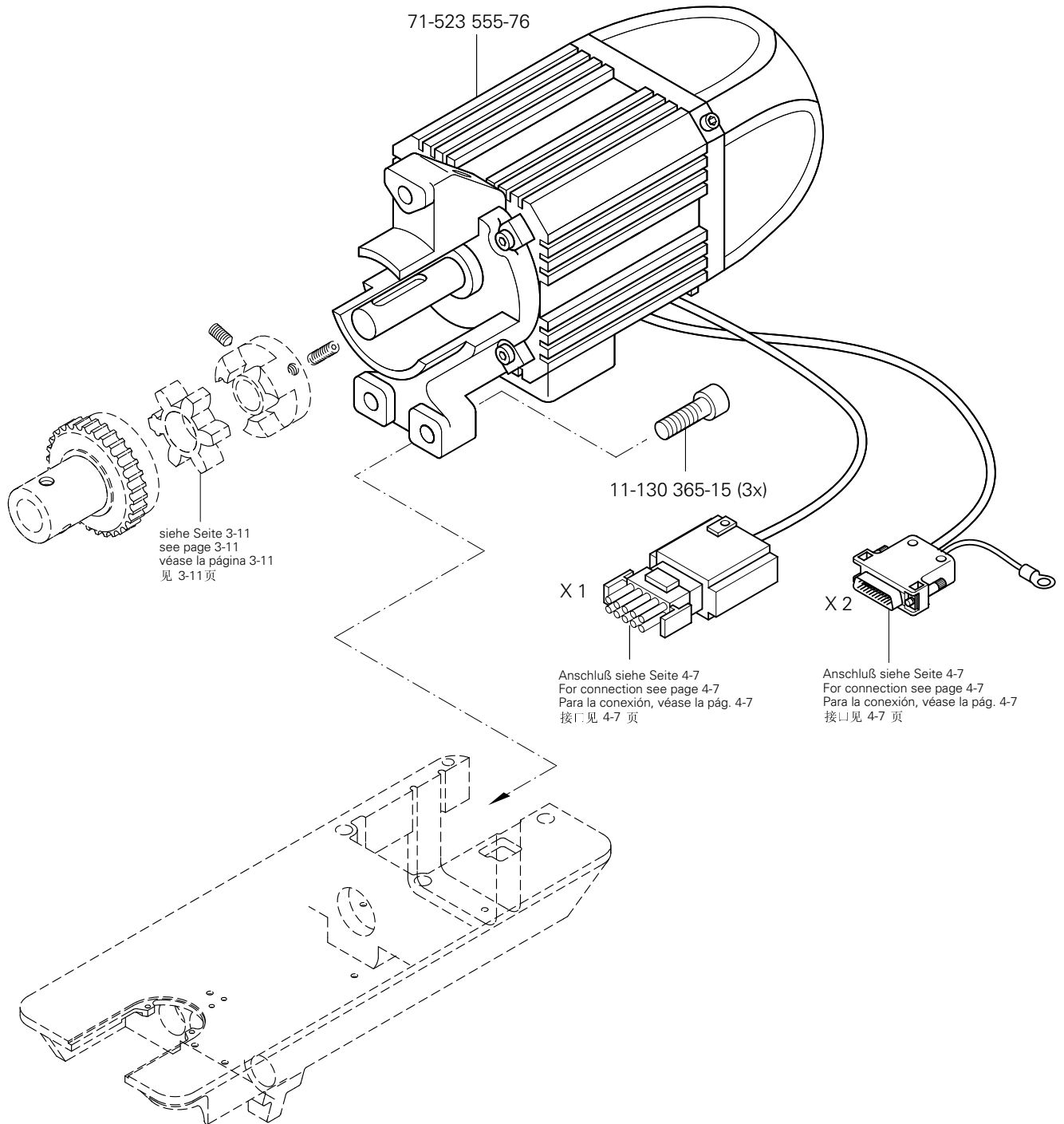

# 4.04

Oberteilerkennung und Einschaltsperr  
 Sewing head identification and start inhibitor  
 Detección de la parte superior y bloqueo de arranque  
 上部机器识别和启动闭锁

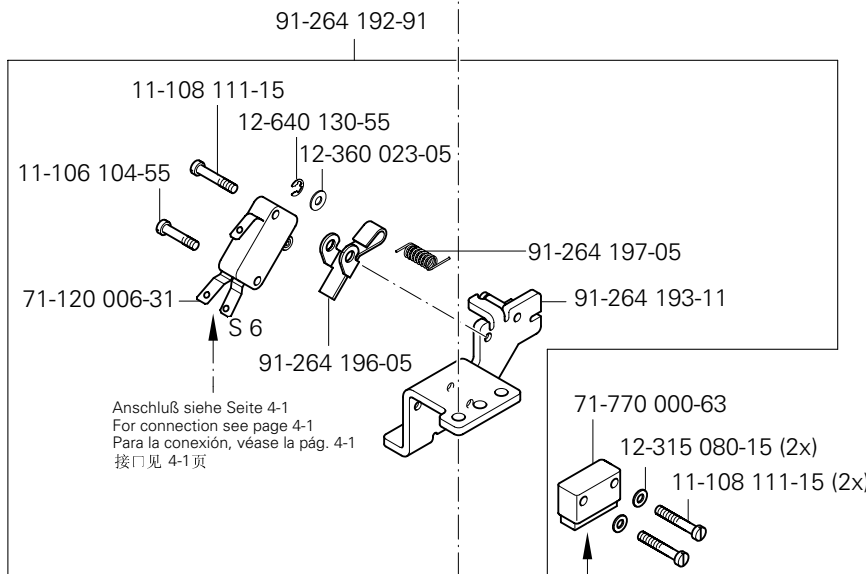
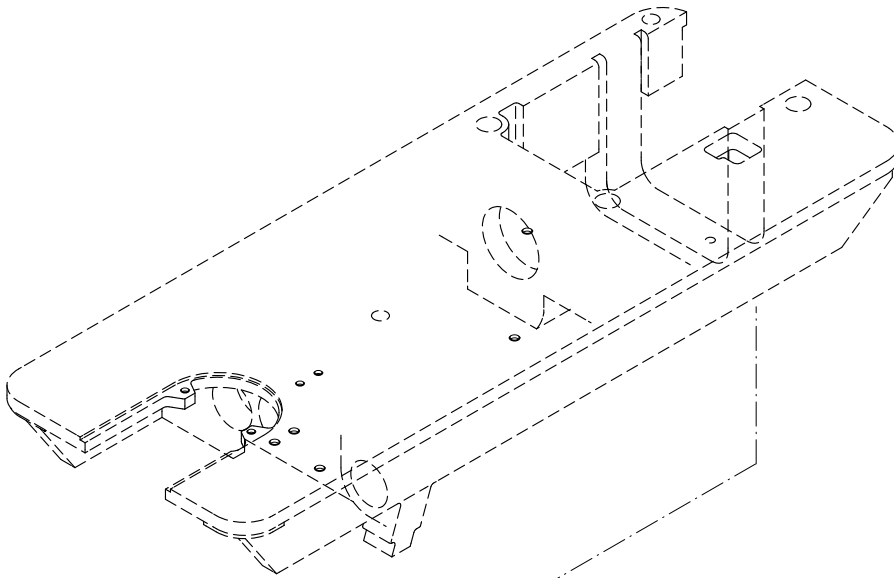
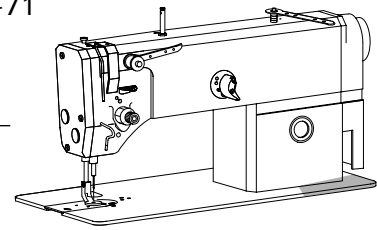

Anschluß siehe Seite 4-1  
 For connection see page 4-1  
 Para la conexión, véase la pág. 4-1  
 接口见 4-1页

Anschluß siehe Seite 4-1  
 For connection see page 4-1  
 Para la conexión, véase la pág. 4-1  
 接口见 4-1页

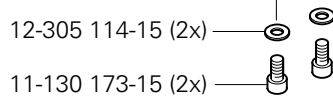
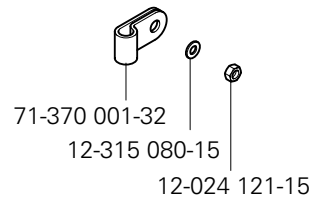



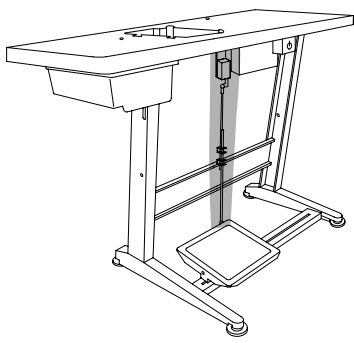

Sollwertgeber  
Set-point generator  
Emisor del valor teóruco  
给定值发生器

PFAFF 1183-712/02

4.05

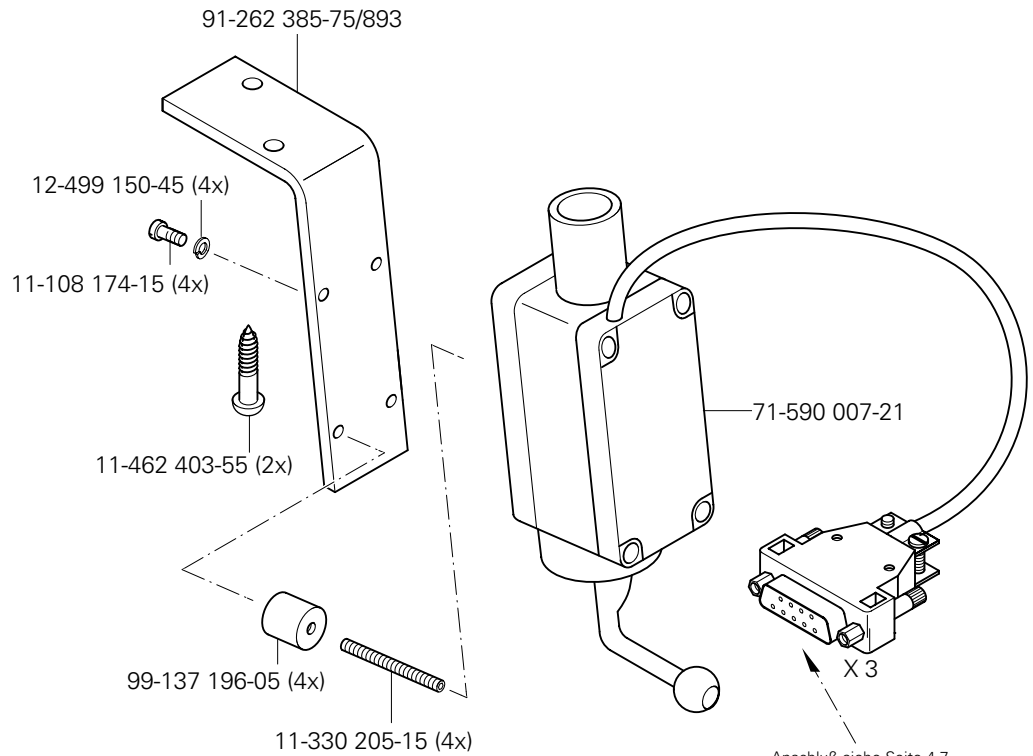

Anschluß siehe Seite 4-7  
For connection see page 4-7  
Para la conexión, véase la pág. 4-7  
接口见 4-7页

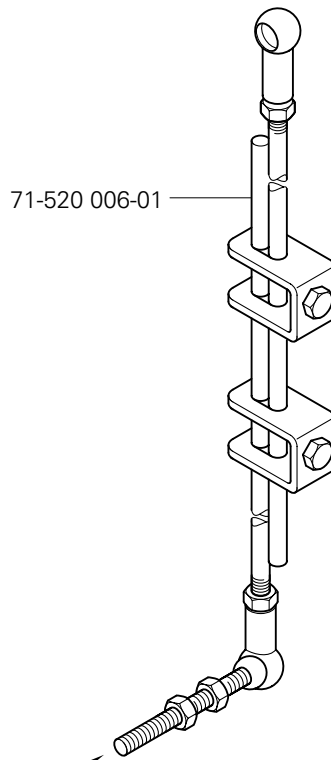

Zur Tretplatte  
For the pedal  
Para el pedal  
用于踏板

# 4.06

Motor-Hauptschalter  
Main switch  
Interruptor principal  
电机主开关

PFAFF 1183-712/02

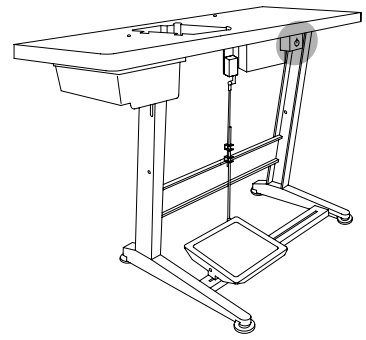

71-370 001-08

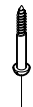

11-460 163-15

Anschluß siehe Seite 4-7  
For connection see page 4-7  
Para la conexión, véase la pág. 4-7  
接口见 4-7页

91-229 180-90 90/1

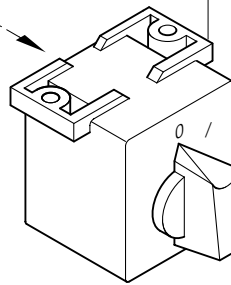

71-370 002-92



11-460 250-15 (2x)

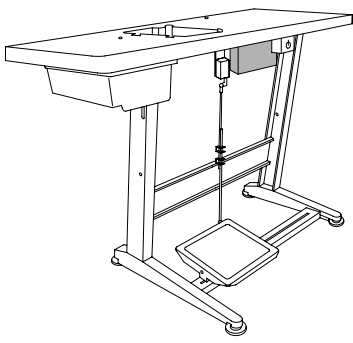

Steuerkasten  
Control box  
Caja de mandos  
控制箱

PFAFF 1183-712/02

4.07

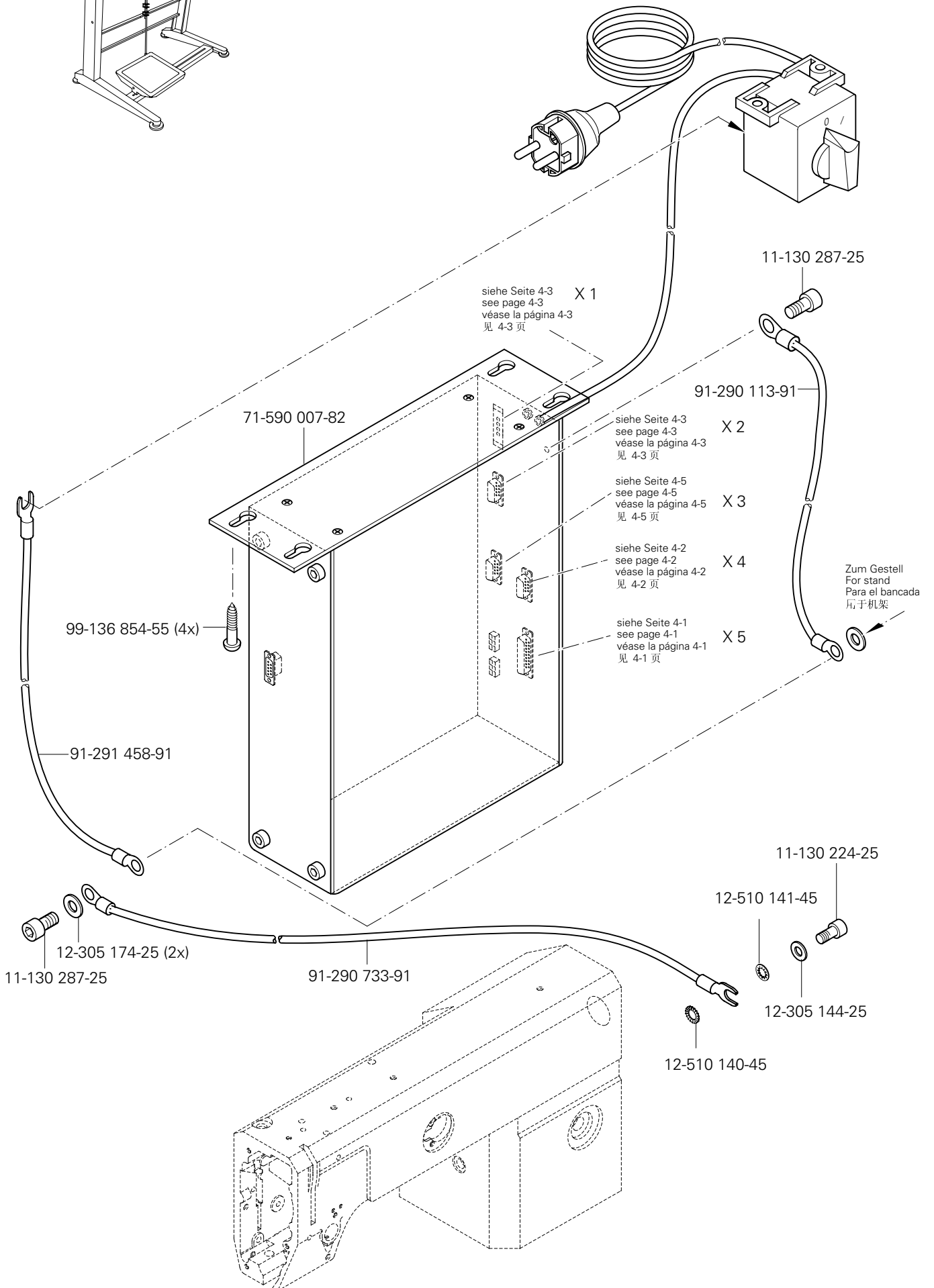

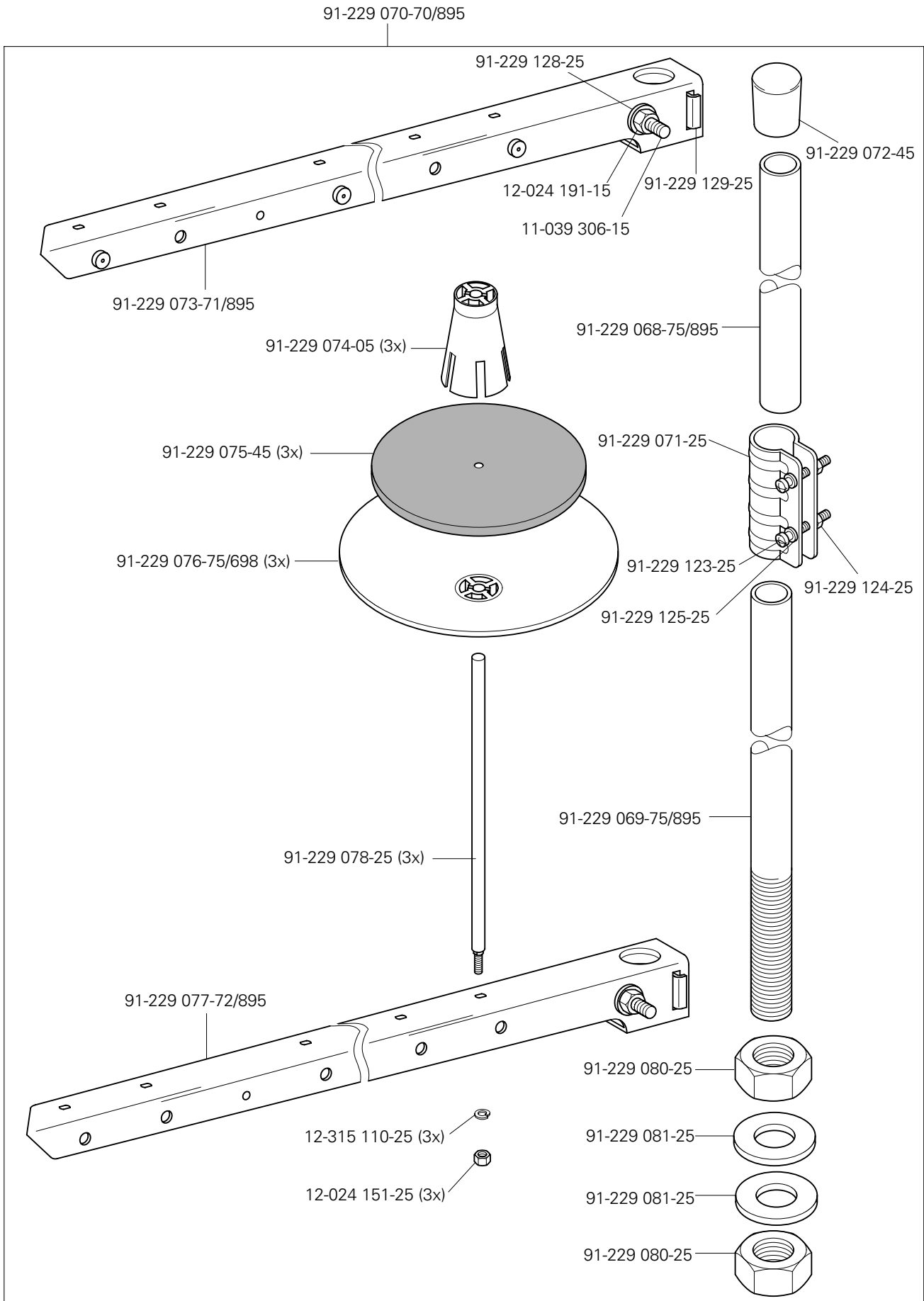

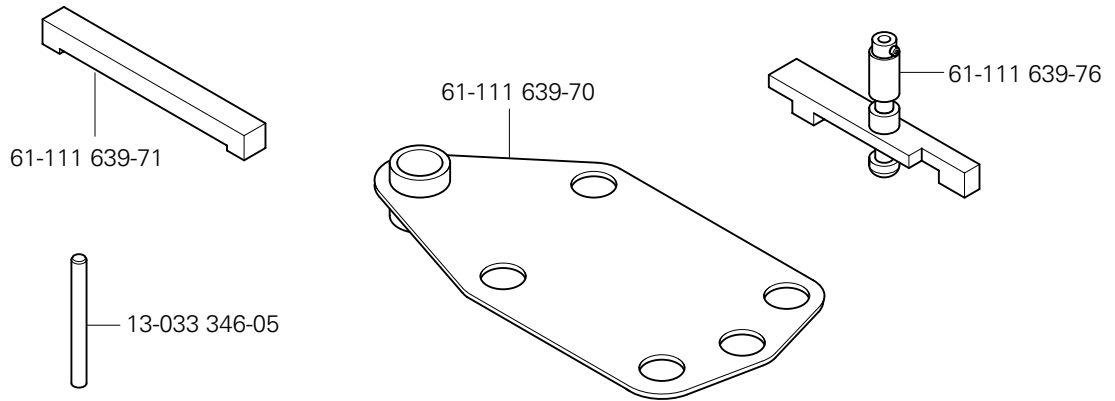

Teile zur Tischplatte  
Parts for table top  
Piezas para el tablero  
用于台板的零件

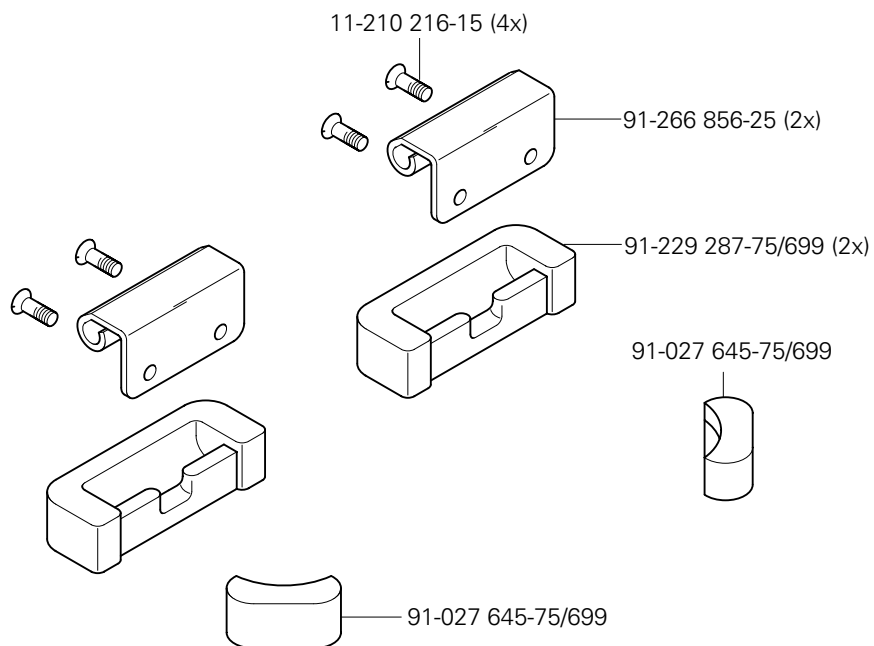

Öl Oil Aceite 油	Mittelpunkts-Viskosität bei: Mean viscosity at: Viscosidad media a: 中点粘度:		Dichte bei: Density of: Densidad a: 密度, 在:		Bestellnummer für Behälter mit: Part number for can with: Número de pedido para recipientes con: 订货号用于油箱, 带:		
	°C	mm <sup>2</sup> /s	°C	g/cm <sup>3</sup> (g/ml)	1 Liter 1 Litro 1 升	5 Liter 5 Litro 5 升	10 Liter 10 Litro 10 升
28-011 201-05	40	10,0	15	0,847	91-027 975-91	91-027 976-91	91-027 977-91

Fett Grease Grasa 脂	Penetration Penetration Penetración 贯入度	Tropfpunkt Drip-point Punto de goteo 滴点	Bestellnummer für Behälter mit: Part number for can with: Número de pedido para recipientes con: 订货号用于油箱, 带:				
			mm/10	°C	0,25 kg	0,5 kg	1 kg
28-011 202-05							28-011 202-05
28-011 202-47	220-250	185					28-011 202-47
28-011 202-70	265-295	192					28-011 202-70

Reinigungsmittel Cleansing agent Limpiadores 清洁剂	Bestellnummer für Behälter mit: Part number for can with: Número de pedido para recipientes con: 订货号用于油箱, 带:		
	240 ml		
Isoprophyl-Alkohol 异丙醇	95-665 735-91		

No. 零件号	Seite Page Página 页号	No. 零件号	Seite Page Página 页号	No. 零件号	Seite Page Página 页号	No. 零件号	Seite Page Página 页号
11-039 306-15	5 - 1	11-225 223-15	3 - 3	12-360 061-05	3 - 11	14-018 624-91	3 - 6
11-106 104-55	4 - 4	11-250 084-25	3 - 7	12-360 063-05	3 - 5	14-026 902-01	3 - 6
11-108 084-15	3 - 9	11-314 946-15	3 - 4	12-360 064-05	3 - 3	14-210 010-01	3 - 5
11-108 087-15	3 - 9	11-330 085-15	3 - 3	12-499 150-45	4 - 5	14-218 050-01	3 - 5
11-108 111-15	4 - 4	11-330 175-15	3 - 7	12-499 190-45	3 - 10	14-602 901-01	3 - 7
11-108 174-15	4 - 1, 4 - 5	11-330 205-15	4 - 5	12-510 111-25	4 - 2	16-409 983-05	3 - 11
11-108 174-25	3 - 2	11-330 220-15	3 - 3, 3 - 4	12-510 140-45	4 - 7	25-161 801-49	3 - 3, 3 - 9
11-108 177-15	3 - 12	11-330 277-15	3 - 5, 3 - 6, 3 - 9	12-510 141-45	4 - 7	25-161 801-52	3 - 3
11-108 222-15	3 - 9	11-330 280-15	3 - 6	12-610 200-45	3 - 5	26-536 301-09	3 - 3, 3 - 9
11-108 222-25	3 - 1	11-330 952-15	3 - 7, 3 - 9, 3 - 10, 3 - 11	12-610 210-45	3 - 3, 3 - 11	28-011 201-05	8 - 1
11-130 089-15	3 - 4	11-330 960-15	3 - 11	12-610 230-45	3 - 9	28-011 202-05	8 - 1
11-130 170-25	3 - 1	11-330 964-15	3 - 5, 3 - 6, 3 - 11	12-610 250-45	3 - 11	28-011 202-47	8 - 1
11-130 173-15	3 - 1, 3 - 4, 3 - 10, 4 - 4	11-330 968-15	3 - 11	12-618 170-45	3 - 1	28-011 202-70	8 - 1
11-130 176-15	3 - 3, 3 - 10	11-335 085-15	3 - 9	12-618 190-45	3 - 7	61-111 639-70	6 - 1
11-130 185-15	3 - 1	11-335 280-15	3 - 6, 3 - 11	12-624 210-45	3 - 2	61-111 639-71	6 - 1
11-130 224-15	3 - 5	11-341 277-15	3 - 2, 3 - 3	12-640 130-55	3 - 7, 4 - 4	61-111 639-76	6 - 1
11-130 224-25	3 - 1, 4 - 7	11-460 163-15	4 - 6	12-640 150-55	3 - 10	71-120 006-31	4 - 4
11-130 233-15	3 - 5	11-460 250-15	4 - 6	12-640 190-55	3 - 5	71-170 002-24	3 - 10
11-130 251-15	3 - 1	11-462 403-55	4 - 5	12-640 210-55	3 - 5	71-370 001-08	4 - 6
11-130 257-25	3 - 1	12-024 121-15	4 - 4	12-660 390-45	3 - 9	71-370 001-32	4 - 4
11-130 287-15	3 - 10	12-024 151-25	5 - 1	12-710 190-02	3 - 10	71-370 001-35	4 - 1
11-130 287-25	4 - 7	12-024 191-25	3 - 7, 5 - 1	13-030 341-05	3 - 1	71-370 002-92	4 - 6
11-130 293-15	3 - 1, 3 - 5	12-305 114-15	3 - 3, 3 - 10, 4 - 4	13-033 190-05	3 - 9	71-520 006-01	4 - 5
11-130 293-25	4 - 2	12-305 144-25	4 - 7	13-033 346-05	6 - 1	71-523 555-76	4 - 3
11-130 365-15	4 - 3	12-305 174-25	4 - 7	13-052 085-55	3 - 6	71-590 007-21	4 - 5
11-132 172-15	3 - 4	12-315 080-15	4 - 4	13-063 193-05	3 - 9	71-590 007-70	4 - 2
11-132 223-15	3 - 2	12-315 110-25	5 - 1	13-250 097-25	3 - 3	71-590 007-72	4 - 2
11-173 168-25	3 - 4	12-335 171-15	3 - 5	14-012 525-01	3 - 10	71-590 007-82	4 - 7
11-180 283-25	3 - 1	12-349 901-05	3 - 9	14-012 916-01	3 - 11	71-590 007-91	4 - 2
11-210 168-25	3 - 4, 3 - 7	12-360 023-05	4 - 4	14-016 080-01	3 - 9	71-770 000-63	4 - 4
11-210 216-15	6 - 1	12-360 033-05	3 - 5, 3 - 10	14-016 101-91	3 - 11	91-000 621-15	3 - 8
11-210 265-15	3 - 6	12-360 043-05	3 - 10	14-016 151-91	3 - 6	91-002 262-25	3 - 4
11-225 172-25	3 - 1	12-360 054-05	3 - 5	14-016 171-91	3 - 11	91-006 814-05	3 - 4

No. 零件号	Seite Page Página 页号	No. 零件号	Seite Page Página 页号	No. 零件号	Seite Page Página 页号	No. 零件号	Seite Page Página 页号
91-010 215-05	3 - 4	91-166 452-21	3 - 7	91-229 180-90	4 - 6	91-262 689-91	3 - 6
91-014 346-05	3 - 4	91-167 590-15	3 - 1	91-229 287-75/699	6 - 1	91-262 690-01	3 - 6
91-020 324-05	3 - 10	91-168 192-25	3 - 4	91-262 061-05	3 - 11	91-262 691-91	3 - 3
91-027 645-75/699	6 - 1	91-168 193-05	3 - 4	91-262 161-72/698	3 - 6	91-262 692-05	3 - 3
91-027 975-91	8 - 1	91-168 194-71/698	3 - 4	91-262 162-75/698	3 - 1	91-262 761-71/895	3 - 1
91-027 976-91	8 - 1	91-168 480-15	3 - 6	91-262 183-75/895	3 - 1	91-262 787-91	3 - 3
91-027 977-91	8 - 1	91-170 677-45	3 - 4	91-262 185-05	3 - 9	91-262 788-91	3 - 3
91-056 192-25	3 - 7	91-171 042-05	3 - 7	91-262 187-15	3 - 9	91-262 804-91	3 - 8
91-056 193-25	3 - 7	91-171 049-05	3 - 7	91-262 188-15	3 - 9	91-262 805-25	3 - 8
91-056 197-91	3 - 7	91-171 785-05	3 - 9	91-262 189-91	3 - 9	91-262 806-05	3 - 8
91-056 198-21	3 - 7	91-174 253-25	3 - 2	91-262 195-92	3 - 6	91-262 819-05	3 - 3
91-056 578-91	3 - 7	91-174 455-15	3 - 4	91-262 196-05	3 - 6	91-262 842-92	3 - 9
91-056 760-05	3 - 7	91-174 783-05	3 - 7	91-262 208-05	3 - 9	91-262 843-01	3 - 11
91-069 105-25	3 - 4	91-174 879-05	3 - 7	91-262 209-91	3 - 9	91-262 844-92	3 - 11
91-069 562-05	3 - 2	91-175 549-05	3 - 2	91-262 228-01	3 - 12	91-262 845-91	3 - 11
91-069 585-25	3 - 7	91-229 068-75/895	5 - 1	91-262 235-15	3 - 9	91-262 846-05	3 - 11
91-086 126-21	3 - 2	91-229 069-75/895	5 - 1	91-262 250-91	3 - 9	91-262 959-71/699	3 - 1
91-086 130-01	3 - 2	91-229 070-70/895	5 - 1	91-262 304-45	3 - 3	91-262 985-25	3 - 1
91-100 281-25	3 - 7	91-229 071-25	5 - 1	91-262 326-15	3 - 1	91-262 986-91	3 - 9
91-100 400-15	3 - 6	91-229 072-45	5 - 1	91-262 329-75/895	3 - 1	91-262 988-91	3 - 9
91-105 447-25	3 - 4	91-229 073-71/895	5 - 1	91-262 354-05	3 - 3	91-264 144-75/895	3 - 1
91-118 570-92	3 - 6	91-229 074-05	5 - 1	91-262 360-05	3 - 9	91-264 154-25	3 - 8
91-118 683-05	3 - 7	91-229 075-45	5 - 1	91-262 376-91	3 - 9	91-264 192-91	4 - 4
91-150 847-25	3 - 8	91-229 076-75/698	5 - 1	91-262 377-91	3 - 9	91-264 193-11	4 - 4
91-154 855-21	3 - 2	91-229 077-72/895	5 - 1	91-262 385-75/893	4 - 5	91-264 196-05	4 - 4
91-161 334-25	3 - 4	91-229 078-25	5 - 1	91-262 437-05	3 - 9	91-264 197-05	4 - 4
91-162 578-71/698	3 - 1	91-229 080-25	5 - 1	91-262 536-15	3 - 1	91-264 233-15	3 - 1
91-162 596-25	3 - 4	91-229 081-25	5 - 1	91-262 538-05	3 - 5	91-264 240-05	3 - 9
91-162 597-05	3 - 9	91-229 123-25	5 - 1	91-262 544-91	3 - 6	91-264 266-91	3 - 5
91-162 690-92	3 - 2	91-229 124-25	5 - 1	91-262 566-05	3 - 11	91-264 267-91	3 - 5
91-162 694-05	3 - 2	91-229 125-25	5 - 1	91-262 566-92	3 - 11	91-264 268-05	3 - 5
91-162 984-05	3 - 2	91-229 128-25	5 - 1	91-262 576-05	3 - 11	91-264 269-07	3 - 5
91-165 685-05	3 - 9	91-229 129-25	5 - 1	91-262 688-91	3 - 6	91-264 270-01	3 - 5



No. 零件号	Seite Page Página 页号	No. 零件号	Seite Page Página 页号	No. 零件号	Seite Page Página 页号	No. 零件号	Seite Page Página 页号
91-264 271-01	3 - 5	91-700 996-15	3 - 7				
91-264 275-07	3 - 5	95-665 735-91	8 - 1				
91-264 276-92	3 - 5	95-669 358-05	3 - 9				
91-264 277-91	3 - 5	95-774 310-91	3 - 10				
91-264 278-05	3 - 5	95-774 311-01	3 - 10				
91-264 280-92	3 - 5	95-774 313-91	3 - 10				
91-264 281-92	3 - 2	95-774 314-01	3 - 10				
91-264 282-91	3 - 3	95-774 317-05	3 - 10				
91-264 284-91	3 - 3	95-774 318-01	3 - 10				
91-264 286-91	3 - 4	95-774 324-11	3 - 10				
91-264 287-05	3 - 4	95-774 325-02	3 - 11				
91-264 288-01	3 - 4	95-774 327-91	3 - 1				
91-264 292-92	3 - 6	95-774 464-25	3 - 7				
91-264 297-71/698	3 - 4	95-774 465-25	3 - 7				
91-264 312-91	3 - 9	95-774 466-91	3 - 7				
91-264 313-05	3 - 9	95-774 467-05	3 - 7				
91-264 338-15	3 - 9	95-784 333-91	4 - 1				
91-264 357-05	3 - 7	99-136 854-55	4 - 7				
91-264 358-05	3 - 7	99-137 151-45	3 - 7				
91-264 364-05	3 - 11	99-137 186-05	3 - 9				
91-264 365-91	3 - 11	99-137 187-15	3 - 9				
91-265 065-05	3 - 9	99-137 188-15	3 - 9				
91-266 397-01	3 - 7	99-137 190-05	3 - 9				
91-266 757-05	3 - 4	99-137 191-05	3 - 9				
91-266 856-25	6 - 1	99-137 192-05	3 - 9				
91-268 076-15	3 - 9	99-137 193-05	3 - 9				
91-268 668-75/895	4 - 2	99-137 194-05	3 - 9				
91-268 671-70/895	4 - 2	99-137 196-05	4 - 5				
91-290 113-91	4 - 7	99-137 247-45	3 - 1				
91-290 733-91	4 - 7	99-137 405-05	3 - 9				
91-291 133-91	3 - 4						
91-291 458-91	4 - 7						
91-700 335-25	3 - 1						

# PFAFF

## PFAFF Industrie Maschinen AG

Postfach 3020  
D-67653 Kaiserslautern

Königstr. 154  
D-67655 Kaiserslautern

Telefon: (0631) 200-0  
Telefax: (0631) 17202  
E-Mail: [info@pfaff-industrial.com](mailto:info@pfaff-industrial.com)