

# mitsubishi

## 三菱工業用ミシン部品カタログ

## Industrial Sewing Machine Parts Catalog

Model PLK-E4030  
PLK-E6030

	目次	CONTENTS	Page
A	本体構成	Construction .....	1
B	本体関係(1)	Arm bed & it's accessories (1) .....	2
C	本体関係(2)	Arm bed & it's accessories (2) .....	4
D	本体関係(3)	Arm bed & it's accessories (3) .....	6
E	縫い機構(1)	Sewing mechanism (1) .....	8
F	縫い機構(2)	Sewing mechanism (2) .....	10
G	中押え機構	Presser bar lifting mechanism .....	12
H	糸切り機構	Thread trimming mechanism .....	14
J	糸緩め機構	Tension release mechanism .....	16
K	X-Yテーブル機構(1)	X-Y table mechanism (1) .....	18
L	X-Yテーブル機構(2)	X-Y table mechanism (2) .....	20
M	外押え機構	Work holder mechanism .....	22
N	ワイパー機構	Wiper mechanism .....	24
P	給油機構	Oil lubrication mechanism .....	26
Q	配線・配管関係	Cable component & Pneumatic control unit .....	28
R	テーブル関係	Table & Stand .....	30
S	付属品	Accessories .....	32
T	オプションパーツ	Option parts .....	34
	索引	Index .....	36

## 部品コードの採番形式

### MITSUBISHI SPARE PARTS No. Designation system

#### 1. 部品コードについて CONCERNING PARTS CODE.

部品をご注文される場合は、部品コードをお知らせください。

Please inform the part number, when these parts are ordered.

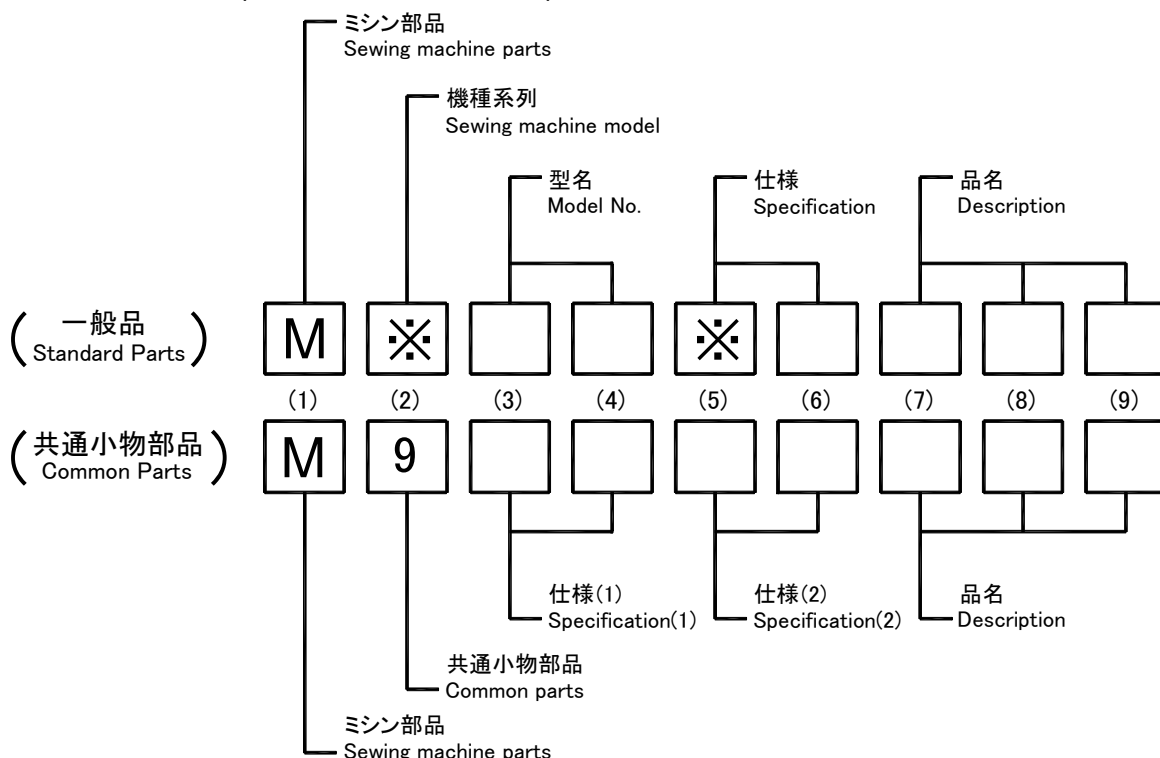

[ 例 ]  
Example

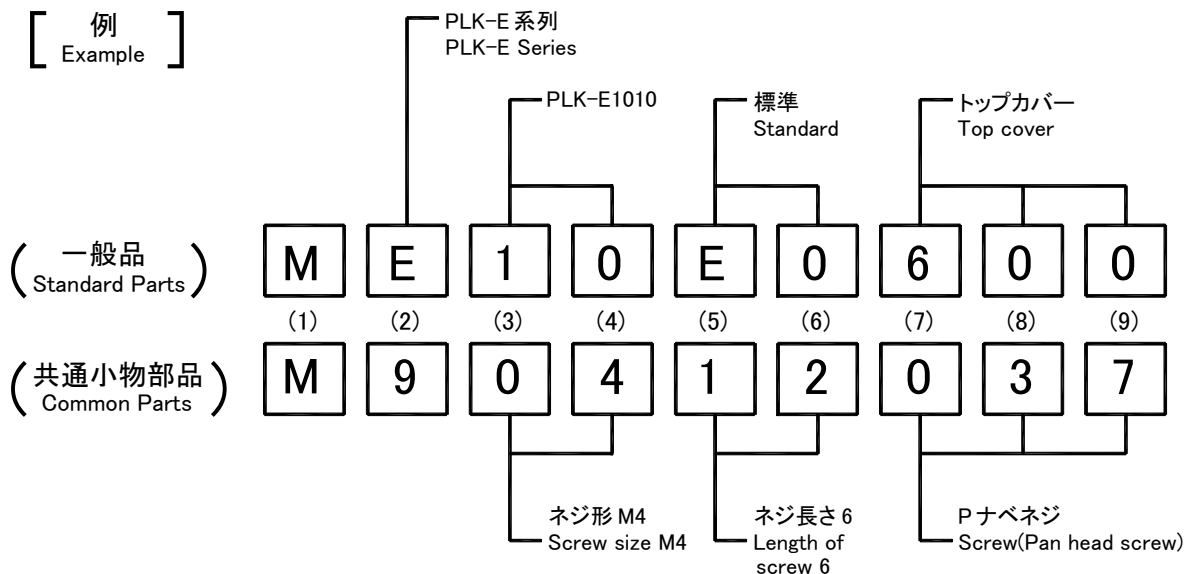

#### 2. 変更マークについて CONCERNING MODIFICATION MARK.

変更マーク欄に \* 記号のある部品は、形状、寸法などの変更履歴がありますので、ご注文の際にはご使用の製品の製造番号と合わせてご覧ください。

The parts marked with \* in the modification column has been changed the shape or size etc. So when these modified parts are ordered please inform the serial number of the sewing machine.

注: 一般品についての機種型名は、その部品が最初に使用された機種型名を示します。

従って長期にわたる場合は、機種の変更が行われるため、当初の機種以外の機種で使用されている場合があります。

Sewing machine Models, of Standard Parts are Indicated model of these parts are registered firstly. Parts are used for not only the indicated model, but also another models, in reason of New development, improvement after.

A 全体構成  
CONSTRUCTION

---

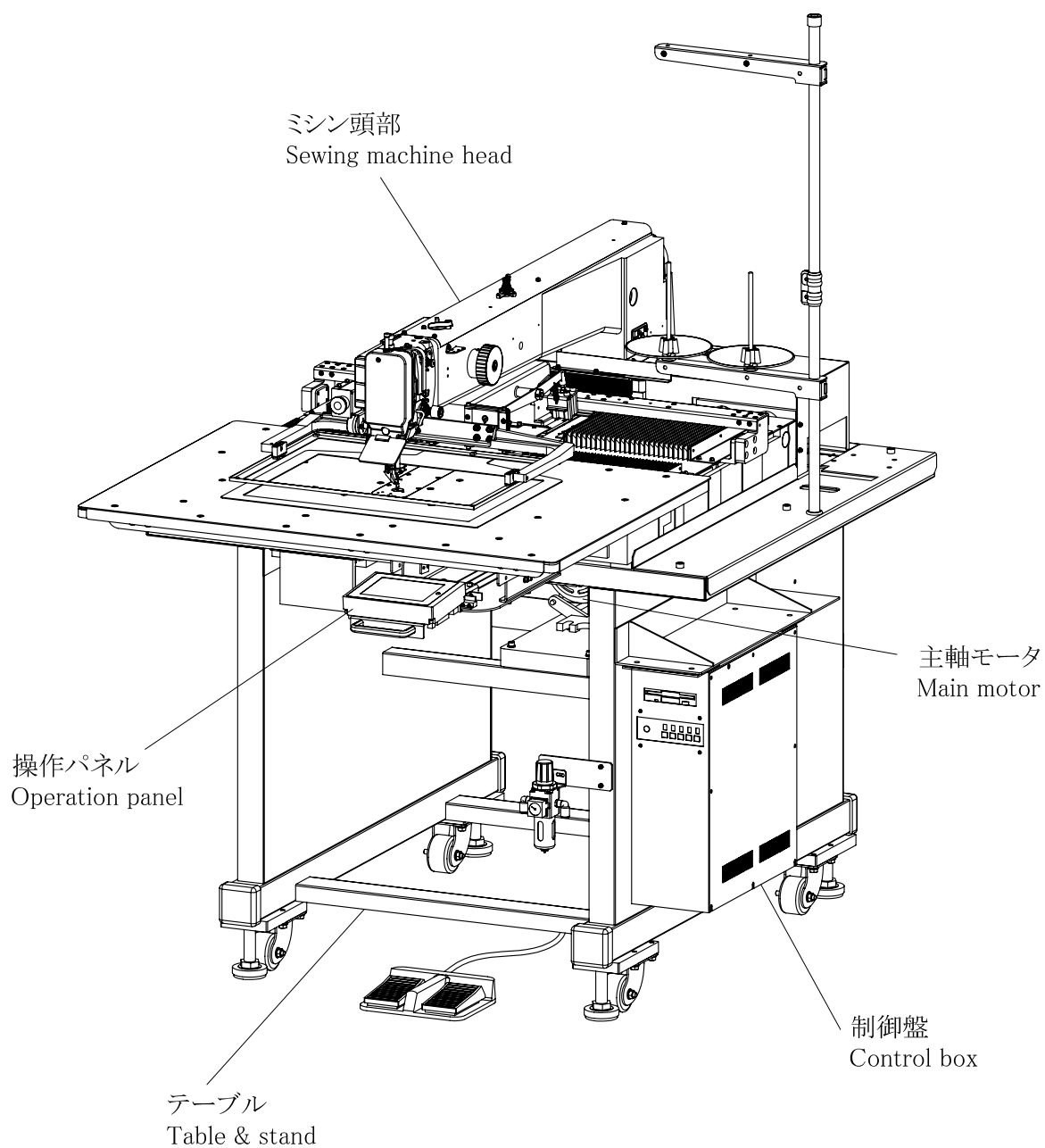

注1：モータ部分は三菱リミサーボX部品カタログを参照ください。

注2：Fig.No.の採番していない部品は単体で支給することは出来ません。Setにて支給いたします。

Remarks 1) Concerning about the motor parts please refer to the parts catalog of MITSUBISHI LIMISERVO X.

Remarks 2) The parts which Fig.No. are not marked are not available individually. It can be supplied with the whole component.

**B** 本体関係(1)  
ARM BED & IT'S ACCESSORIES(1)

---

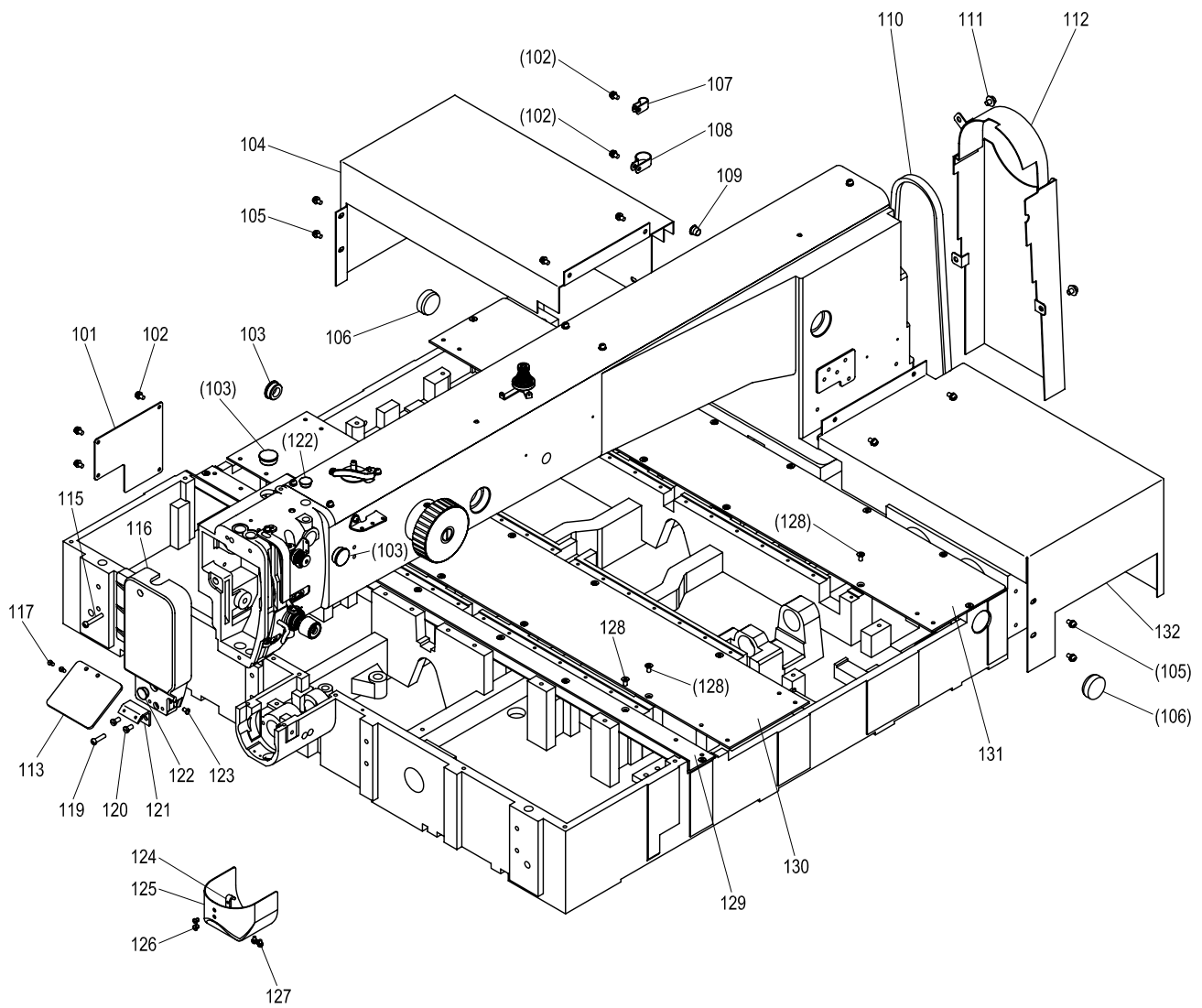

[B]本体関係(1)  
ARM BED & IT'S ACCESSORIES (1)

Fig no.	変更 Mod.	部品コード Parts no.	品名	Description	数量	
					Amt. Req. 4030	6030
B 101		ME10A0742	フタ	Cover	1	1
B 102		M91054004	SW-PWプラマイナネジ M4X8	Screw M4X8	12	12
B 103		M91910080	ゴムセン φ19	Rubber plug φ19	3	3
B 104		MB35A0849	モータカバー (ヒタリ)	Motor cover (left)	1	*
B 104		MB65A0849	モータカバー (ヒタリ)	Motor cover (left)	*	1
B 105		M91071004	SW-MWプラマイナネジ M4X8	Screw M4X8	9	11
B 106		M92701080	ゴムセン φ27	Rubber plug φ27	2	2
B 107		MN60A0620	ナイロンクリップ AB-5N	Nylon clip AB-5N	7	7
B 108		MB60A1620	ナイロンクリップ AB-8N	Nylon clip AB-8N	1	1
B 109		M90883080	ゴムセン φ8.8	Rubber plug φ8.8	1	1
B 110		ME40A0777	Vベルト 48	V belt M48	1	1
B 111		M91300004	SW-MWプラマイナネジ M5X8	Screw M5X8	3	3
B 112		MB35E0776	ベルトカバー	Belt cover	1	1
B 113		MS01A0160	アイガード	Eye guard	1	1
B 115		M90447037	プラマイナネジ M4X25	Screw M4X25	1	1
B 116		ME10E1830	メンイタ	Face cover	1	1
B 117		M90806002	ヒラネジ 1/8(44)X6	Screw 1/8(44)X6	2	2
B 119		M90442037	プラマイナネジ M4X16	Screw M4X16	1	1
B 120		M91110002	ヒラネジ 11/64(40)X8	Screw 11/64(40)X8	2	2
B 121		MB60A0601	アイガードトリツケイタ	Eye guard bracket	1	1
B 122	A	M91182080	ゴムセン φ11.8	Rubber plug φ11.8	2	2
B 123		M90908003	マルヒラネジ 9/64(40)X6	Screw 9/64(40)X6	1	1
B 124		MS01A0361	カケカネ	Latch	1	1
B 125		MB60E6339	シリンダーカバー	Cylinder cover	1	1
B 126		M90906003	マルヒラネジ 9/64(40)X3.2	Screw 9/64(40)X3.2	2	2
B 127		M90859004	SW-PWプラマイナネジ M3X6	Screw M3X6	2	2
B 128		M90436037	サラネジ M4X8	Screw M4X8	28	38
B 129		MA35A8339	カバー (マエ)	Cover (front)	1	*
B 129		MA60A3339	カバー (マエ)	Cover (front)	*	1
B 130		MA35A9339	カバー (ナカ)	Cover (middle)	1	*
B 130		ME60A0339	カバー (ナカ)	Cover (middle)	*	1
B 131		MA35A7339	カバー (ウシロ)	Cover (rear)	1	*
B 131		MA60A1339	カバー (ウシロ)	Cover (rear)	*	1
B 132		MB35A1849	モータカバー (ミキ)	Motor cover (right)	1	*
B 132		MB65A1849	モータカバー (ミキ)	Motor cover (right)	*	1

**C** 本体関係(2)  
 ARM BED & IT'S ACCESSORIES(2)

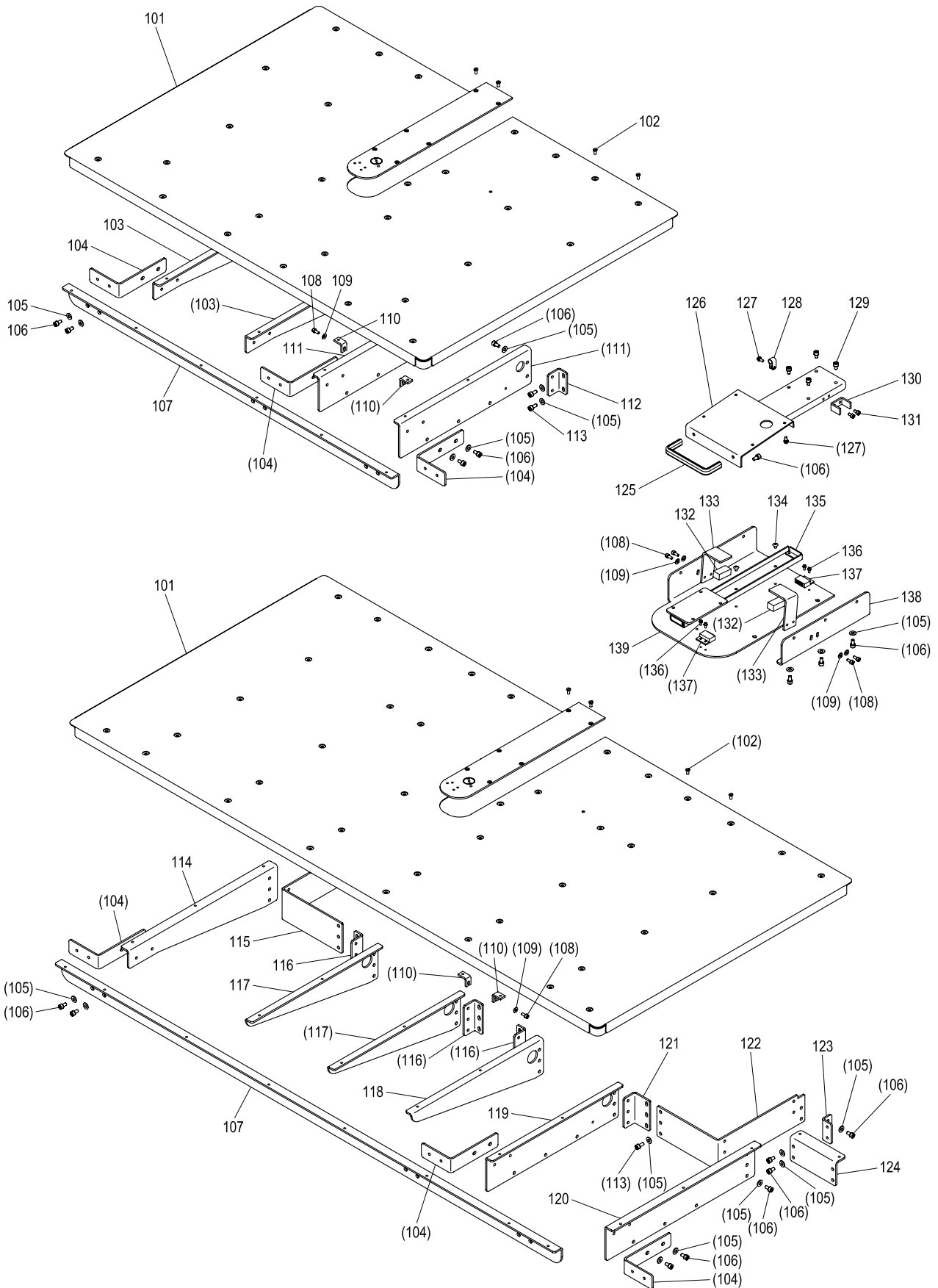

[C]本体関係(2)

ARM BED & IT'S ACCESSORIES (2)

Fig no.	変更 Mod.	部品コード Parts no.	品名	Description	数量	
					Amt. 4030	Req. 6030
C 101	ME40A0470	スベリイタ	Slide plate	1	*	
C 101	ME60A0470	スベリイタ	Slide plate	*	1	
C 102	M90992002	ヒラネジ M4X8	Screw M4X8	30	42	
C 103	ME40A0429	ササエカナク (ヒタリ)	Bracket (left)	2	*	
C 104	ME40A0758	ブラケット	Bracket	3	3	
C 105	M90511050	ワッシャー 5	Washer 5	37	69	
C 106	M95005017	セフティソケット M5X10	Bolt M5X10	31	49	
C 107	ME40A0799	ホキョウイタ	Stiffening plate	1	*	
C 107	ME60A0799	ホキョウイタ	Stiffening plate	*	1	
C 108	M94001017	セフティソケット M4X10	Bolt M4X10	6	6	
C 109	M90421050	ワッシャー 4	Washer 4	6	6	
C 110	MB62A4601	トリツケイタ	Adapter	2	2	
C 111	ME40A1429	ササエカナク (ミキ)	Bracket (right)	2	*	
C 112	MA35A0361	Lタイプカナク	L-type bracket	4	*	
C 113	M95002017	セフティソケット M5X12	Bolt M5X12	8	22	
C 114	ME60A0429	ササエカナク (ヒタリ)	Bracket (left)	*	1	
C 115	MA60A0601	ササエトリツケイタ (ヒタリ)	Bracket (left)	*	1	
C 116	MA20A0361	Lタイプカナク	L-type bracket	*	3	
C 117	MA60A5426	ササエカナク (ヒタリ)	Bracket (left)	*	2	
C 118	MA60A4426	ササエカナク (ミキ)	Bracket (right)	*	1	
C 119	ME60A1429	ササエカナク (ミキ)	Bracket (right)	*	1	
C 120	ME60A2429	ササエカナク (ミキ)	Bracket (right)	*	1	
C 121	ME60A0361	Lタイプカナク	L-type bracket	*	1	
C 122	MA60A1601	ササエトリツケイタ (ミキ)	Bracket (right)	*	1	
C 123	ME60A1361	Lタイプカナク	L-type bracket	*	2	
C 124	ME60A3429	ササエカナク	Bracket	*	2	
C 125	ME40A0604	トッテ	Handle	1	1	
C 126	ME40A0715	パネルトレイ	Panel tray	1	1	
C 127	M91056004	SW-PWフライナネジ M4X10	Screw M4X10	5	5	
C 128	MS14A1620	ナイロンクリップ AB-4N	Nylon clip AB-4N	1	1	
C 129	M91511056	セフティソケット M5X8	Bolt M5X8	4	4	
C 130	MB50S0370	キーパ	Keeper	1	1	
C 131	M94002017	セフティソケット M4X8	Bolt M4X8	2	2	
C 132	ME40A0419	ホウシシゴム	Rubber cushion	2	2	
C 133	ME40A0601	ゴムトリツケイタ	Spring	2	2	
C 134	M90445037	Ptラスネジ M4X6	Screw M4X6	3	3	
C 135	ME40A0481	スライドパック	Slide guide	1	1	
C 136	M90816004	SW-PWフライナネジ M3X8	Screw M3X8	4	4	
C 137	MB50S0809	マグネットキャッチ	Magnet catcher	2	2	
C 138	ME40A1601	パネルシュウノウベーストリツケイタ	Panel storage base bracket	1	1	
C 139	ME40A0770	パネルシュウノウベース	Panel storage base	1	1	

D 本体関係(3)  
 ARM BED & IT'S ACCESSORIES(3)

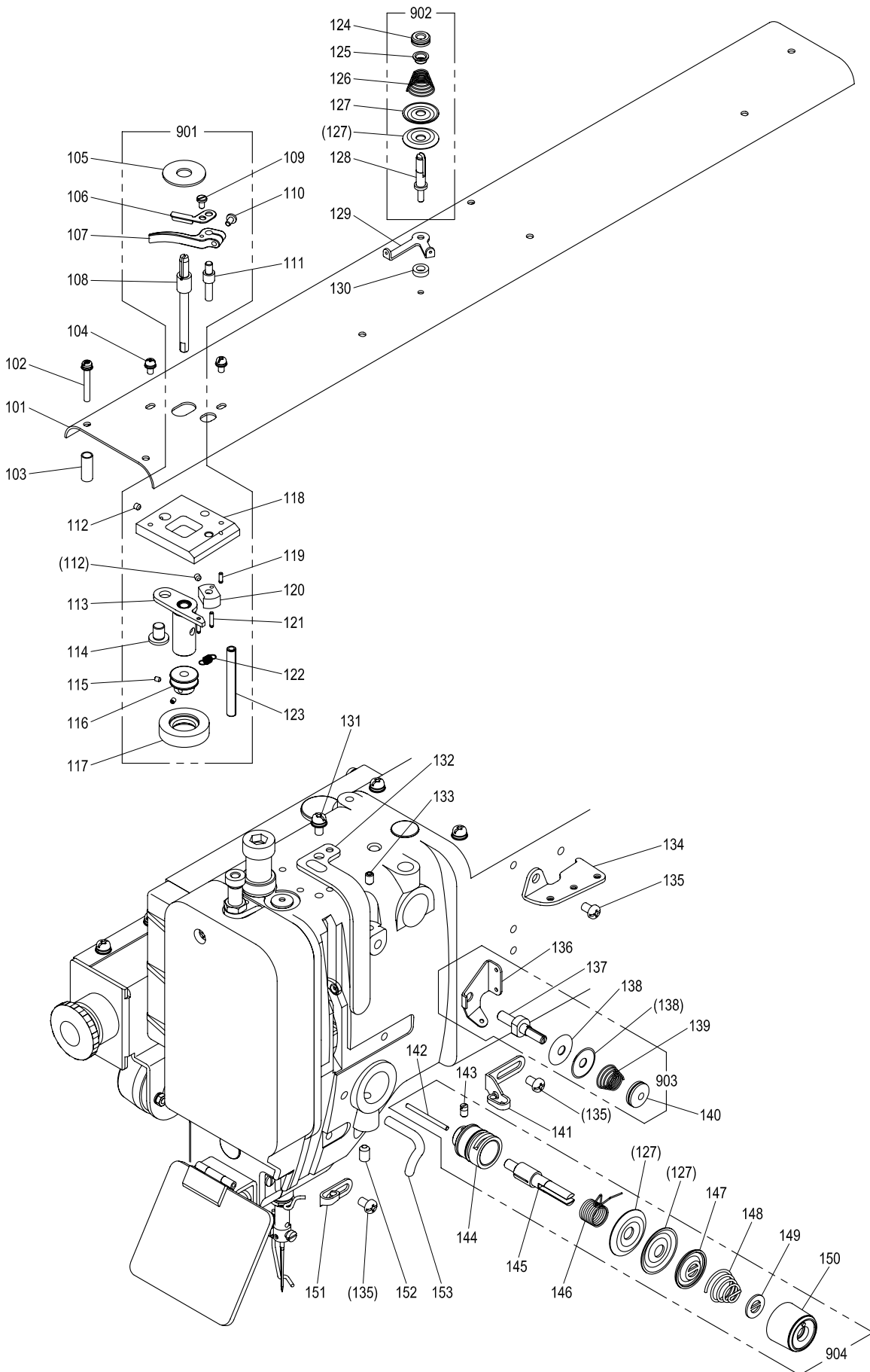



[D]本体関係(3)  
ARM BED & IT'S ACCESSORIES(3)

Fig no.	変更 Mod.	部品コード Parts no.	品名	Description	数量	
					Amt. Req. 4030	6030
D 101		MB35A0600	トップカバー	Top cover	1	1
D 102		M91276004	SW-PWプラマイナネジ M4X30	Screw M4X30	5	5
D 103		MB62A0352	スペーサ 1382312-60200	Spacer	5	5
D 104		M91013004	SW-MWプラマイナネジ M4X10	Screw M4X10	2	2
D 105		MA20A0476	スペーサー	Spacer	1	1
D 106		ME25A0551	チョウセツイタ	Adjuster plate	1	1
D 107		ME25A0950	レバー	Lever	1	1
D 108		MA04A1530	ダンツキジク D	Driven shaft	1	1
D 109		M90920002	ヒラネジ 9/64(40)X6.5	Screw 9/64(40)X6.5	1	1
D 110		M90939002	ヒラネジ 9/64(40)X11	Screw 9/64(40)X11	1	1
D 111		MA04A2530	ダンツキジク	Shaft	1	1
D 112		M91055020	ロッカクアナツキトメネジ M4X4	Screw M4X4	2	2
D 113		MB60E0950	レバークミタテ	Lever	1	1
D 114		M99006063	ピン	Pin	1	1
D 115		M91057020	ロッカクアナツキトメネジ M3X4	Screw M3X4	2	2
D 116		MA20A0194	イマキグルマ	Wheel	1	1
D 117		MS03A0417	ゴムワ	Tire	1	1
D 118		MB60A1601	トリツケイタ	Bracket	1	1
D 119		M91004067	ミゾツキピン BXガタ φ2.5X8	Pin φ2.5X8	1	1
D 120		MS14A0350	カム	Cam	1	1
D 121		M91005067	ミゾツキピン BXガタ φ2.5X12	Pin φ2.5X12	2	2
D 122		MS14A0572	ツルマキハネ	Spring	1	1
D 123		M90601064	スプリングピン φ6X56	Pin φ6X56	1	1
D 124		M91602046	ツマミナット	Thumb nut	1	1
D 125		MM11A0702	ハネアンナイ	Spring guide	1	1
D 126		MM11A0245	エンスイハネ	Thread tension spring	1	1
D 127		MF10A0555	チョウシガラ	Thread tension discs	4	4
D 128		MS14A0553	チョウシホウ	Thread tension stud	1	1
D 129		MS14A0180	トアンナイ	Thread guide	1	1
D 130		MG75A1476	スペーサ	Spacer	1	1
D 131		M91054004	SW-PWプラマイナネジ M4X8	Screw M4X8	1	1
D 132		MA20A0584	テンピンカバー	Thread take-up lever guard	1	1
D 133		M91053020	ロッカクアナツキトメネジ M4X6	Screw M4X6	1	1
D 134		MF36A1180	トアンナイ	Thread guide	1	1
D 135		M91011004	プラマイナネジ M4X6	Screw M4X6	3	3
D 136		MF00A0181	トアンナイ	Thread guide	1	1
D 137		MF00A0553	チョウシホウ	Thread tension stud	1	1
D 138		MF10A1555	チョウシガラ	Thread tension discs	2	2
D 139		MF36A0245	エンスイハネ	Thread tension spring	1	1
D 140		M91101046	ツマミナット	Thumb nut	1	1
D 141		MG43A0181	トアンナイ	Thread guide	1	1
D 142		M90204060	ピン	Pin	1	1
D 143		M90901002	ヒラネジ 9/64(40)X4	Screw 9/64(40)X4	1	1
D 144		MF10A0709	ブッシュ	Regulator casing	1	1
D 145		MF10A0553	チョウシホウ	Thread tension stud	1	1
D 146		MF10A0187	イトリハネ	Thread take-up spring	1	1
D 147		MM11A0556	チョウシガラオサエ	Disc retaining plate	1	1
D 148		MN52A1245	エンスイハネ	Thread tension spring	1	1
D 149		MT60A0802	マワリトメ	Thumb nut revolution stopper	1	1
D 150		M91605045	ツマミナット	Thumb nut	1	1
D 151		MF10A0181	トアンナイ	Thread guide	1	1
D 152		M95004020	ロッカクアナツキトメネジ M5X8	Screw M5X8	1	1
D 153		MF70A1180	トアンナイ	Thread guide	1	1
D 901		MB60E0190	イマキソウチクミタテ	Bobbin winder	1	1
D 902		MS14E0180	チョウセツキミタテ	Thread tension Regulator assy	1	1
D 903		MF00E0550	チョウセツキミタテ	Thread tension Regulator assy	1	1
D 904		MA16E0210	チョウセツキミタテ	Thread tension Regulator assy	1	1

E 縫い機構(1)  
SEWING MECHANISM(1)

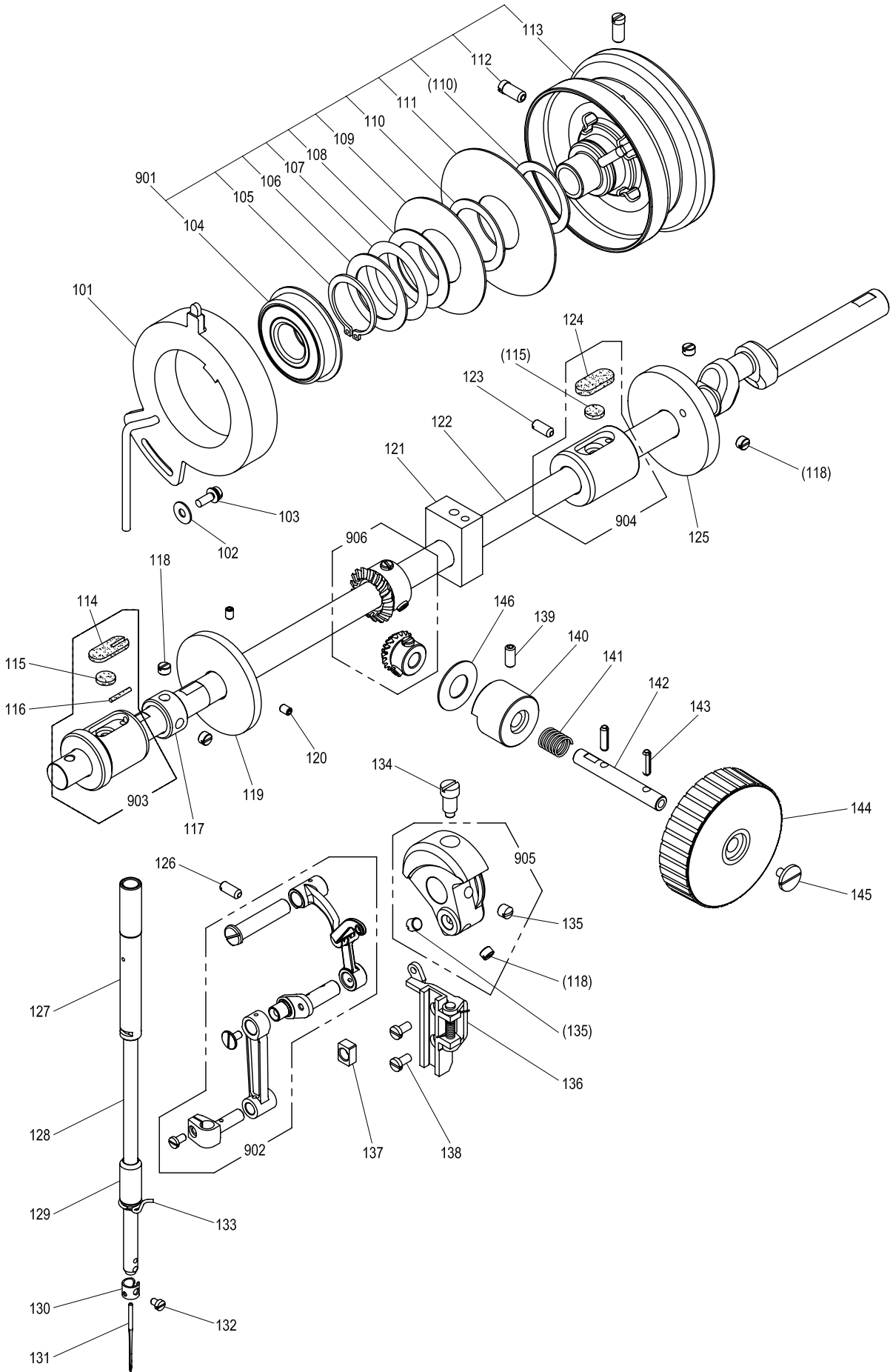

## [E]縫い機構(1)

## SEWING MECHANISM (1)

Fig no.	変更 Mod.	部品コード Parts no.	品名	Description	数量	
					Amt. Req. 4030	6030
E 101		MB60A2406	ウワジクケンシュツキ	Detector	1	1
E 102		M90421050	サガネ 4	Washer 4	1	1
E 103		M91059004	SW-PWプラマイナベネジ M4X12	Screw M4X12	1	1
E 104		MN10A1456	ボールベアリング	Ball bearing	1	1
E 105		M90330065	Cガ外ワ 30	C-type retaining ring 30	1	1
E 106		M93001050	サガネ	Washer	1	1
E 107		MF01A0259	ナミサガネ	Wave washer	1	1
E 108		MF01A1476	スパーサー B	Spacer B	1	1
E 109		MN72A1694	ハンシャパン F20 (ウワイチ)	Command disk F20 (up)	1	1
E 110		MF01A0476	スパーサー A	Spacer A	2	2
E 111		MB60A0694	ハンシャパン K10 (シタイチ)	Command disk K10 (down)	1	1
E 112		M91520002	ヒラネジ 15/64(28)X12	Screw 15/64(28)X12	2	2
E 113		MB60E0682	プーリ	Pulley	1	1
E 114		MG50A0740	フェルト	Felt	1	1
E 115		MS10A1740	フェルト	Felt	2	2
E 116		MV88A0740	フェルト	Felt	1	1
E 117		MF70A0352	カラー	Collar	1	1
E 118		M91602001	トメネジ 1/4(40)X4	Screw 1/4(40)X4	5	5
E 119		MS14A0682	イトマキプーリ	Pulley	1	1
E 120		M91053020	ロッカクアナツキトメネジ M4X6	Screw M4X6	2	2
E 121		MA35A0833	メタル	Bushing	1	1
E 122		MB35A0230	ウワジク	Drive shaft	1	1
E 123		M91223001	トメネジ M5X10	Screw M5X10	1	1
E 124		MF60A2740	フェルト	Felt	1	1
E 125		MS01A0350	イトキリカム	Thread trimmer cam	1	1
E 126		M91221001	トメネジ M5X12	Screw M5X12	1	1
E 127		MS01A0663	ハリボウメタル (ウエ)	Needle bar bushing (upper)	1	1
E 128		MS01A0660	ハリボウ	Needle bar	1	1
E 129		MG30A0664	ハリボウメタル (シタ)	Needle bar bushing (lower)	1	1
E 130		MF21D0181	イトアンナイ	Thread guide	1	1
E 131		MS02A0128	ミシンハリ DPX17#18	Needle DPX17#18	1	1
E 132		M90815002	ヒラネジ 1/8(44)X4.5	Screw 1/8(44)X4.5	1	1
E 133		MF01A0181	イトアンナイ	Thread guide	1	1
E 134		M91802006	ヒラネジボウサキ 9/32(28)	Set screw 9/32(28)	1	1
E 135		M91606001	トメネジ 1/4(40)X6	Screw 1/4(40)X6	2	2
E 136		MS03E0662	ハリカガイドクミタテ	Guide assy	1	1
E 137		MF10A0325	カクコマ	Square block	1	1
E 138		M90990002	ヒラネジ M4X8	Screw M4X8	2	2
E 139		M95006020	ロッカクアナツキトメネジ M5X12	Screw M5X12	1	1
E 140		ME25A0833	メタル	Bushing	1	1
E 141		MA35A2572	ツルマキハネ	Spring	1	1
E 142		ME25A0454	ジク	Shaft	1	1
E 143		M90406064	スプリングピン φ4X14	Pin φ4X14	2	2
E 144		ME25A0682	テマワシプーリ	Hand pulley	1	1
E 145		M91119002	ヒラネジ	Screw M4X8	1	1
E 901		MB60E1682	プーリクミタテ	Pulley assy	1	1
E 902		MS01E0580	テンピンハリクミタテ	Thread take-up lever assy	1	1
E 903		MS10A0232	ウワジクメタル(ヒタリ)クミ	Drive shaft bushing L assy	1	1
E 904		MB60E0234	ウワジクメタル(ナカ)クミ	Drive shaft bushing C assy	1	1
E 905		MS01A0383	クランククミ	Crank assy	1	1
E 906		ME25E0331	カサハグルマクミ	Bevel gear assy	1	1

F 縫い機構(2)  
SEWING MECHANISM(2)

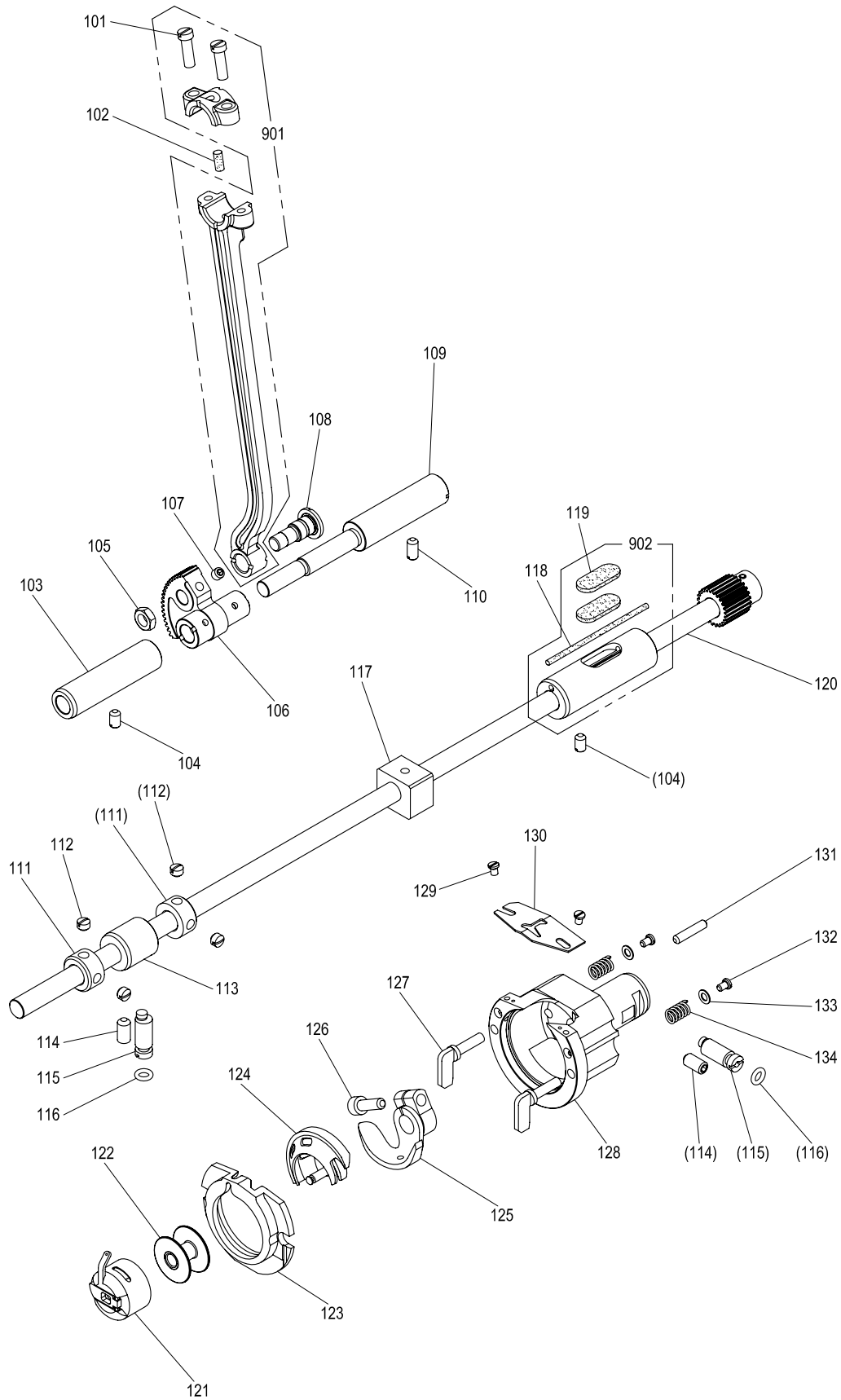

## [F]縫い機構(2)

## SEWING MECHANISM (2)

Fig no.	変更 Mod.	部品コード Parts no.	品 名	Description	数量	
					Amt. Req. 4030	6030
F 101		M91203002	ヒラネジ 3/16(28)X15	Screw 3/16(28)X15	2	2
F 102		MB60A0740	フェルト	Felt	1	1
F 103		MS01A0833	メタル	Bushing	1	1
F 104		M91223001	トメネジ M5X10	Screw M5X10	2	2
F 105		M91802045	ナット 9/32(28)	Nut 9/32(28)	1	1
F 106		MS01A0508	セクタハゲルマ	Sector gear	1	1
F 107		M95004021	ロックアナツキトメネジ M5X5	Screw M5X5	1	1
F 108		M98003015	ヒラネジダツキ 9/32(28)	Screw 9/32(28)	1	1
F 109		MS01A0891	ヨウトウジク	Rock shaft	1	1
F 110		M91221001	トメネジ M5X12	Screw M5X12	1	1
F 111		MM11A0352	カラー	Collar	2	2
F 112		M91503001	トメネジ 15/64(28)X4.5	Screw 15/64(28)X4.5	4	4
F 113		MB62A0453	シタジクメタル(ナカ)	Hook shaft bushing (C)	1	1
F 114		M91650020	ロックアナツキトメネジ M6X8	Screw M6X8	2	2
F 115		MS01A0761	ヘンシンジク	Eccentric shaft	2	2
F 116		M90500085	O リング	O-ring	2	2
F 117		MA35A1833	メタル	Bushing	1	1
F 118		ME10A0148	ヒモ	Oil braid	1	1
F 119		MA20A0740	フェルト	Felt	2	2
F 120		MA35E0450	シタジク クミ	Hook shaft assy	1	1
F 121		MS17A0125	ホビンケース SC-181	Bobbin case	1	1
F 122		MA10A0123	ホビン	Bobbin	1	1
F 123		MS08A0616	ナカガマオサエ	Hook retainer	1	1
F 124		MA10A0120	ナカガマ	Inner hook	1	1
F 125		MS01A0611	ドライハ	Hook driver	1	1
F 126		M95001021	ロックアナツキホルト M5X16	Bolt M5X16	1	1
F 127		MS09A0950	カマオサエツマミ	Hook clamp	2	2
F 128		MS01A0121	ソトガマ	Outer hook	1	1
F 129		M90853002	ヒラネジ 1/8(40)X4	Screw 1/8(40)X4	2	2
F 130		MS01A0329	カマイトアンナイ	Thread guide	1	1
F 131		M90001060	ヘイコウピン M6-4X18	Pin M6-4X18	1	1
F 132		M90802003	マルヒラネジ 1/8(44)X4.5	Screw 1/8(44)X4.5	2	2
F 133		M93006050	サガネ	Washer	2	2
F 134		MS01A0572	ツルマキハネ	Spring	2	2
F 901		MB60E1956	レンセツカン クミ	Connecting rod assy	1	1
F 902		ME10E0452	シタジクメタル(ミキ)クミ	Hook shaft bushing (R) assy	1	1

**G** 中押え機構  
**PRESSER BAR LIFTING MECHANISM**

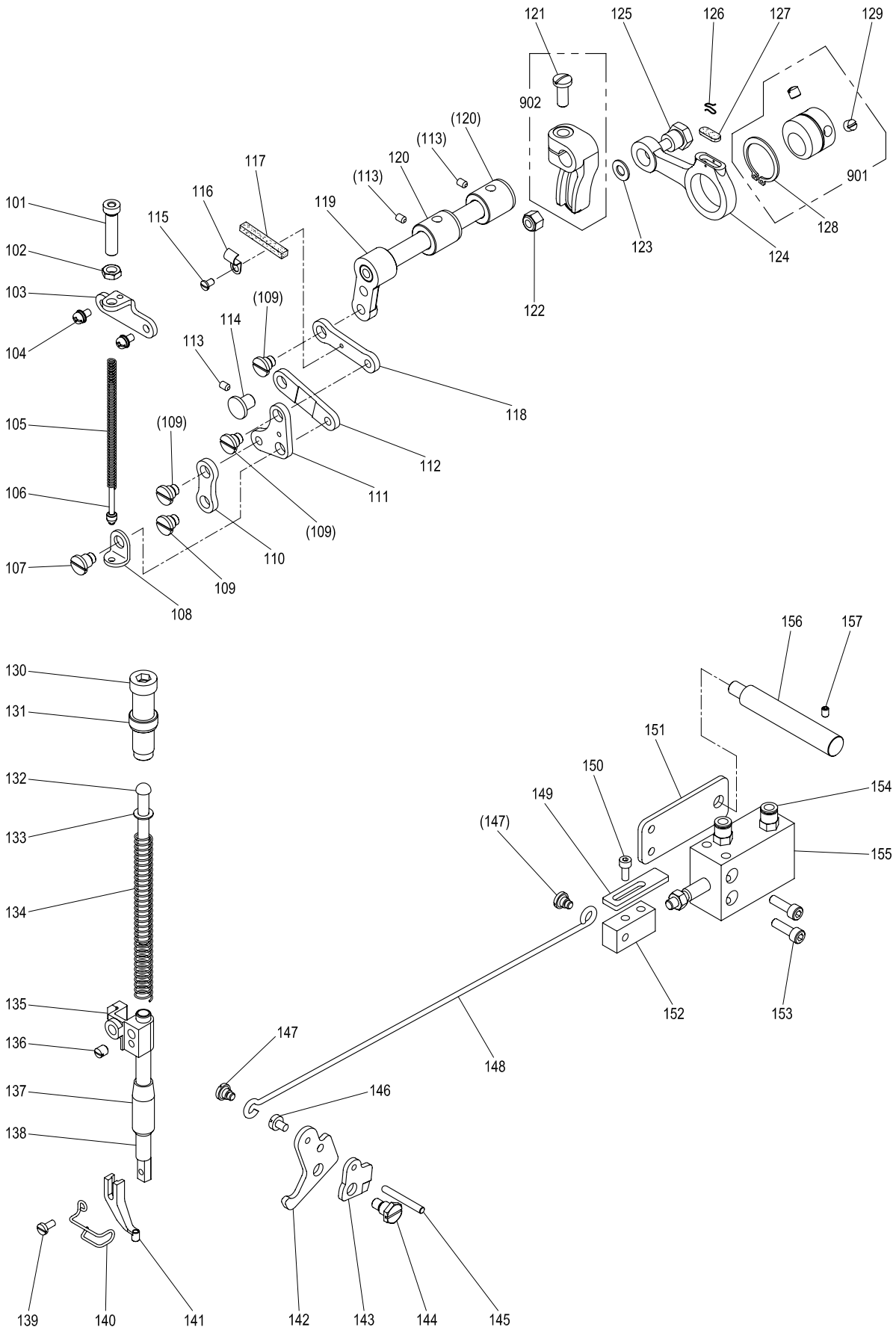

## [G]中押え機構

## PRESSER BAR LIFTING MECHANISM

Fig no.	変更 Mod.	部品コード Parts no.	品名	Description	数量	
					Amt. Req. 4030	6030
G 101		M91801035	ツマミネジ 9/32(28)X35	Thumb screw 9/32(28)X35	1	1
G 102		M91802045	ナット 9/32(28)	Nut 9/32(28)	1	1
G 103		ME10A0261	オサエジョウセツダイ	Bracket	1	1
G 104		M91056004	SW-PWフライナネジ M4X10	Screw M4X10	2	2
G 105		ME10A0572	ツルマキハネ	Spring	1	1
G 106		MS03A6154	アンナイガネ	Spring guide bar	1	1
G 107		M91689015	ヒラネジダンツキ 1/4(40)	Screw 1/4(40)	1	1
G 108		MG30B0226	オサエイタササエ	Supporter	1	1
G 109		M91688015	ヒラネジダンツキ 1/4(40)	Screw 1/4(40)	4	4
G 110		ME10A6910	リンク	Link	1	1
G 111		ME10A0763	ベルクランク	Bell crank	1	1
G 112		ME10A7910	リンク	Link	1	1
G 113		M91058020	ロッカクアナツキトメネジ M4X10	Screw M4X10	3	3
G 114		M99006063	ツハツキシク	Pin	1	1
G 115		M90908003	マルヒラネジ 9/64(40)X6	Screw 9/64(40)X6	1	1
G 116		MN70A1780	ホルダ	Holder	1	1
G 117		MG30A0740	フェルト	Felt	1	1
G 118		ME10A1956	レンセツカン	Link	1	1
G 119		MS02E0460	ウデクミダテ	Arm shaft assy	1	1
G 120		MG30A0833	メタル	Bushing	2	2
G 121		M91603003	マルヒラネジ 1/4(40)X16	Screw 1/4(40)X16	1	1
G 122		M91572045	U ナット 6X0.75	U-nut 6X0.75	1	1
G 123		M90631050	サガネ 6	Washer 6	1	1
G 124		ME10A0956	レンセツカン	Crank rod	1	1
G 125		M91551015	ホルトダンツキ M6	Bolt M6	1	1
G 126		MF60A0700	センサイクハネ	Holder	1	1
G 127		MG30B0740	フェルト	Felt	1	1
G 128		M90325065	Cガトメワ 25	C-type retaining ring 25	1	1
G 129		M91606001	トメネジ 1/4(40)X6	Screw 1/4(40)X6	2	2
G 130		M93202045	ツマミネジ 1/2(28)X43	Thumb screw 1/2(28)X43	1	1
G 131		M93202047	ナット 1/2(28)	Nut 1/2(28)	1	1
G 132		MS03A0703	アンナイボウ	Presser bar guide	1	1
G 133		M90632050	コサガネ 6	Washer 6	1	1
G 134		MS03A1572	ツルマキハネ	Spring	1	1
G 135		MG75A0265	オサエボウダキ	Presser bar holder	1	1
G 136		M91506001	トメネジ 15/64(28)X6	Screw 15/64(28)X6	1	1
G 137		MF10A0267	オサエボウメタル	Bushing	1	1
G 138		MS03A0262	オサエボウ	Presser bar	1	1
G 139		M90922002	ヒラネジ 9/64(40)X8	Screw 9/64(40)X8	1	1
G 140		MB62A0626	ニートルガード	Needle guard	1	1
G 141		MV30A0256	オサエ φ3	Presser foot φ3	1	1
G 142		ME10A1252	オサエアケレバ	Lifting lever	1	1
G 143		MF70A0350	イトユルメカム	Plate cam	1	1
G 144		M91515022	ホルトダンツキ 15/64(28)	Bolt 15/64(28)	1	1
G 145		M90423060	イトユルピン	Pin	1	1
G 146		M91131002	ヒラネジ 11/64(40)X6.5	Screw 11/64(40)X6.5	1	1
G 147		M91219015	ヒラネジダンツキ 3/16(28)	Screw 3/16(28)	2	2
G 148		ME40A0738	ヒキボウ	Link	1	1
G 149		ME25A0477	ストップ	Stopper	1	1
G 150		M95003017	セフティソケット M5X8	Bolt M5X8	1	1
G 151		ME25A0601	トリツケイタ	Adapter	1	1
G 152		ME25A0571	ジョイント	Joint	1	1
G 153		M95006017	セフティソケット M5X22	Bolt M5X22	1	1
G 154		ME40A0571	ワンタッチツキテ	Connector	1	1
G 155		ME25A0434	エアシリンダ	Air cylinder	1	1
G 156		ME25A1454	ジク	Shaft	1	1
G 157		M95004020	ロッカクアナツキトメネジ M5X8	Screw M5X8	1	1
G 901		MG30A0760	ハンシンリンクミダテ	Eccentric cam assy	1	1
G 902		MS02A0463	ウデ (ミキ)	Arm (right)	1	1

**H** 糸切り機構  
 THREAD TRIMMING MECHANISM

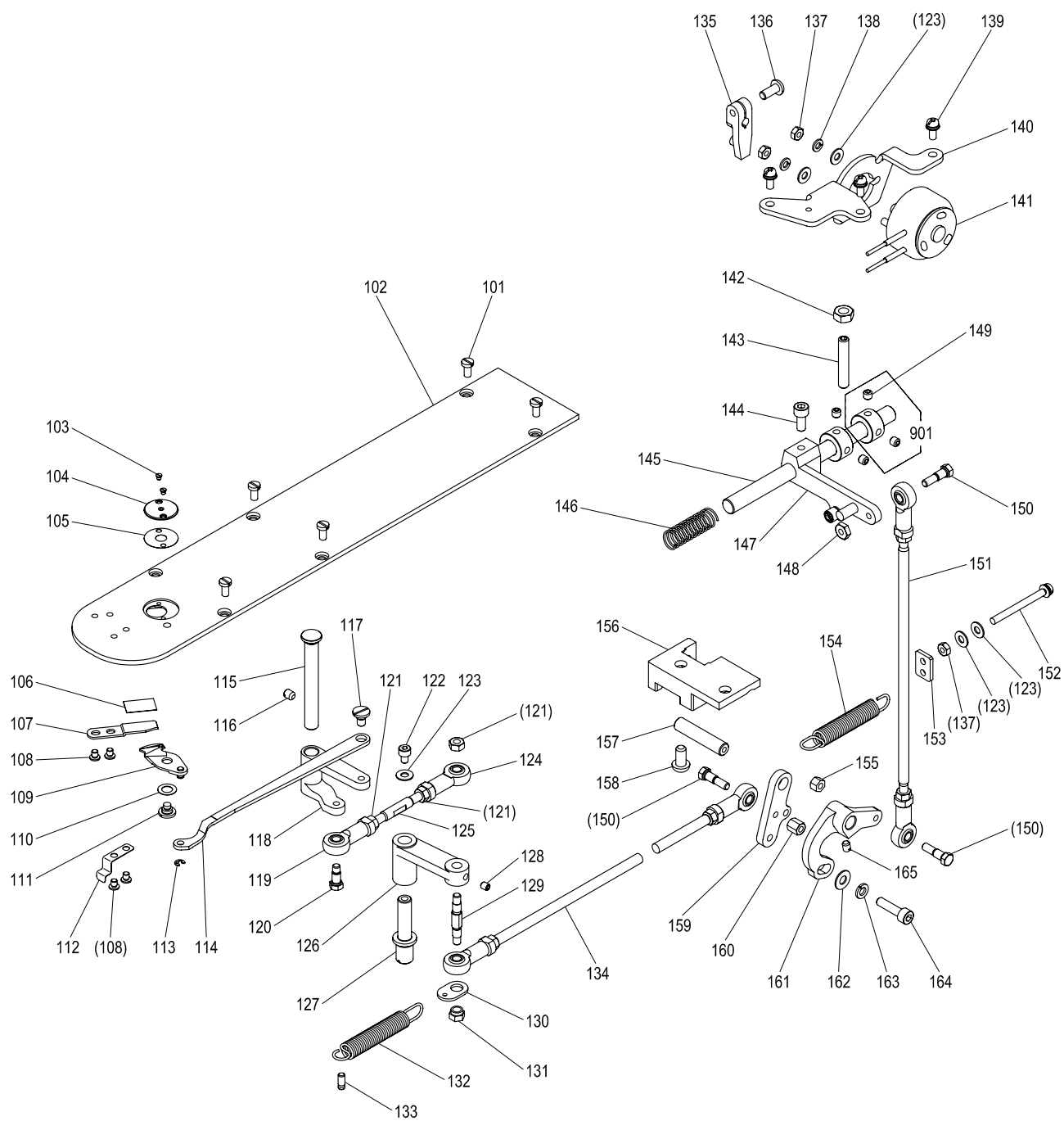



[H]糸切り機構  
 THREAD TRIMMING MECHANISM

Fig no.	変更 Mod.	部品コード Parts no.	品名	Description	数量	
					Amt. 4030	Req. 6030
H 101		M90990002	ヒラネジ M4X8	Screw M4X8	6	6
H 102		MS18A0470	スベリイタ	Slide plate	1	1
H 103		M90605010	サラネジ 3/32(56)X2.8	Screw 3/32(56)X2.8	2	2
H 104		MS03A1101	ハリイタ φ2.2	Needle plate	1	1
H 105		MS01A1476	スベーサ	Spacer	1	1
H 106		MA10B2476	スベーサ	Spacer	1	1
H 107		MS14A0838	コテイメス	Fixed knife	1	1
H 108		M90906003	マルヒラネジ 9/64(40)X3.2	Screw 9/64(40)X3.2	4	4
H 109		MS03B0838	イトウメス	Movable knife	1	1
H 110		M96004052	ウェーブワッシャ 6	Wave washer 6	1	1
H 111		M91129015	ヒラネジダンツキ 11/64(40)	Screw 11/64(40)	1	1
H 112		MS01A0192	イタハネ	Leaf spring	1	1
H 113		M90513065	Eカトメワ 2.5	E-type retaining ring 2.5	1	1
H 114		MA20A1910	リンク	Link	1	1
H 115		MB62A0454	ツハツキシク	Stepped pin	1	1
H 116		M91224001	トメネジ M5X8	Screw M5X8	1	1
H 117		M91214015	ヒラネジダンツキ 3/16(28)	Screw 3/16(28)	1	1
H 118		MA20A0392	メスクドウウテ (3)	Knife driving crank (3)	1	1
H 119		MN55A0975	ロッドエンド	Ball joint	1	1
H 120		M91101017	ホルツダンツキ 11/64(40)	Bolt 11/64(40)	1	1
H 121		M91382045	ナット M5	Nut M5	3	3
H 122		M94001021	ロッカクアナツキホルツ M4X6	Bolt M4X6	1	1
H 123		M90421050	サカネ 4	Washer 4	5	5
H 124		MN72A0975	ロッドエンド	Ball joint	1	1
H 125		M95004023	ウエコミホルツ	Stud bolt	1	1
H 126		MA35A1950	レバ	Lever	1	1
H 127		MA20A4454	ツハツキシク	Stepped pin	1	1
H 128		M91050020	ロッカクアナツキトメネジ M4X5	Screw M4X5	1	1
H 129		MA35A2530	ダンツキシク	Shaft	1	1
H 130		MA35A0708	ハネカケ	Hook	1	1
H 131		M91383045	ナット	Nut	1	1
H 132		MA35A1572	ツルマキハネ	Spring	1	1
H 133		M94002067	ミゾツキピン BXガタ φ4X6	Pin φ4X6	1	1
H 134		MB35E0975	ロッドエンドクミタテ	Connecting rod	1	1
H 135		MS01E0430	イトクリサドウウテ	Crank	1	1
H 136		M95049021	ロッカクアナツキホルツ M5X12	Bolt M5X12	1	1
H 137		M91007045	ナット M4	Nut M4	3	3
H 138		M90424053	ハネサカネ 4	Spring washer 4	2	2
H 139		M91056004	SW-PWフライナベネジ M4X10	Screw M4X10	3	3
H 140		MS14A3601	ソレノイドトリツケイタ	Solenoid bracket	1	1
H 141		ME40E0519	イトクリソレノイド	Solenoid (thread trim)	1	1
H 142		M91576045	ナット M6	Nut M6	1	1
H 143		M91652020	コネジ M6X35	Screw M6X35	1	1
H 144		M95003021	ロッカクアナツキホルツ M5X12	Bolt M5X12	1	1
H 145		MS01A0348	カムシク	Shaft	1	1
H 146		MS01A1572	ツルマキハネ	Spring	1	1
H 147		MS01E0351	カムツイシユウウテクミ	Cam follower assy	1	1
H 148		M91104045	ナット 11/64(40)	Nut 11/64(40)	1	1
H 149		M95004021	ロッカクアナツキトメネジ M5X5	Screw M5X5	4	4
H 150		M90101017	ホルツダンツキ 11/64(40)	Bolt 11/64(40)	3	3
H 151		MS01E0975	ロッドエンドクミタテ (タテ)	Connecting rod (vertical)	1	1
H 152		M91082004	SW-PWフライナベネジ M4X45	Screw M4X45	1	1
H 153		MB35A0708	ハネカケ	Hook	1	1
H 154		MA35A0572	ツルマキハネ	Spring	1	1
H 155		M91102045	ナット 11/64(40)	Nut 11/64(40)	1	1
H 156		MS14A3603	トリツケダイ	Bracket	1	1
H 157		MS08A0454	シク	Shaft	1	1
H 158		M96062021	ロッカクアナツキホルツ M6X12	Bolt M6X12	2	2
H 159		MS01A2392	メスクドウウテ (2)	Knife driving crank (2)	1	1
H 160		M91109045	ロングナット 11/64(40)	Long nut 11/64(40)	1	1
H 161		MS01A1392	メスクドウウテ (1)	Knife driving crank (1)	1	1
H 162		M90511050	サカネ 5	Washer 5	1	1
H 163		M90504053	ハネサカネ 5	Spring washer 5	1	1
H 164		M95015021	ロッカクアナツキホルツ M5X20	Bolt M5X20	1	1
H 165		M91108001	トメネジ 11/64(40)X5.5	Screw 11/64(40)X5.5	1	1
H 901		MS01A3352	カラークミ	Collar assy	2	2

J 糸緩め機構  
TENSION RELEASE MECHANISM

---

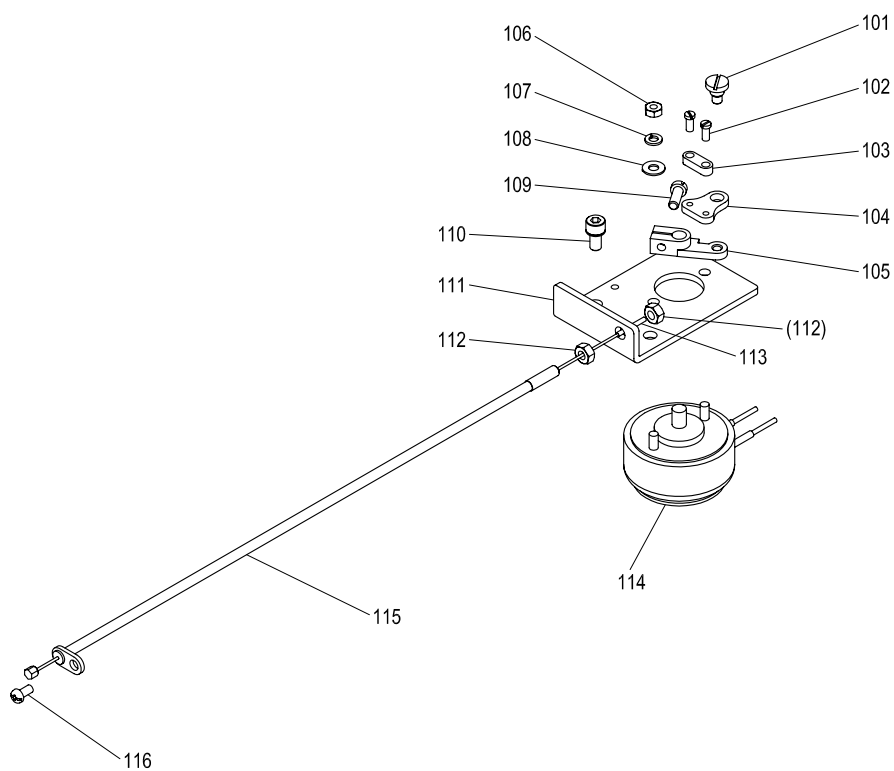

[J]糸緩め機構

TENSION RELEASE MECHANISM

Fig no.	変更 Mod.	部品コード Parts no.	品 名	Description	数量	
					Amt. Req. 4030	6030
J 101		M91127015	ヒラネジ <sup>ダ</sup> ンツキ 11/64(40)·····	Screw 11/64(40)·····	1	1
J 102		M90802002	ヒラネジ <sup>ダ</sup> 1/8(44)X7·····	Screw 1/8(44)X7·····	2	2
J 103		MF36A0750	ホルタ <sup>ダ</sup> ·····	Holder·····	1	1
J 104		MF90A0361	カケガ <sup>ネ</sup> ·····	Bracket·····	1	1
J 105		MS07A0228	ウテ <sup>ダ</sup> ·····	Crank·····	1	1
J 106		M91007045	ナツ <sup>ト</sup> M4·····	Nut M4·····	2	2
J 107		M90424053	ハ <sup>ネ</sup> サカ <sup>ネ</sup> 4·····	Spring washer 4·····	2	2
J 108		M90421050	サ <sup>ガ</sup> ネ 4·····	Washer 4·····	2	2
J 109		M91112002	ヒラネジ <sup>ダ</sup> 11/64(40)X12·····	Screw 11/64(40)X12·····	1	1
J 110		M95005017	セフテイソ <sup>ケ</sup> ット M5X10·····	Bolt M5X10·····	2	2
J 111		MA20A0603	ソレノイ <sup>ト</sup> トリツケ <sup>イ</sup> タ·····	Solenoid bracket·····	1	1
J 112		M91382045	ナツ <sup>ト</sup> M5·····	Nut M5·····	2	2
J 113		MN60A0750	プ <sup>ツ</sup> シュ·····	Pipe·····	1	1
J 114		ME40E1519	イト <sup>コ</sup> ルメソレノイ <sup>ト</sup> ·····	Solenoid (thread release)·····	1	1
J 115		ME40E0746	フレキシブルワイヤ·····	Flexible wire assy·····	1	1
J 116		M91069004	プラマイナ <sup>ハ</sup> ネジ <sup>ダ</sup> M4X8·····	Screw M4X8·····	1	1

**K** X-Yテーブル機構(1)  
 X-Y TABLE MECHANISM(1)

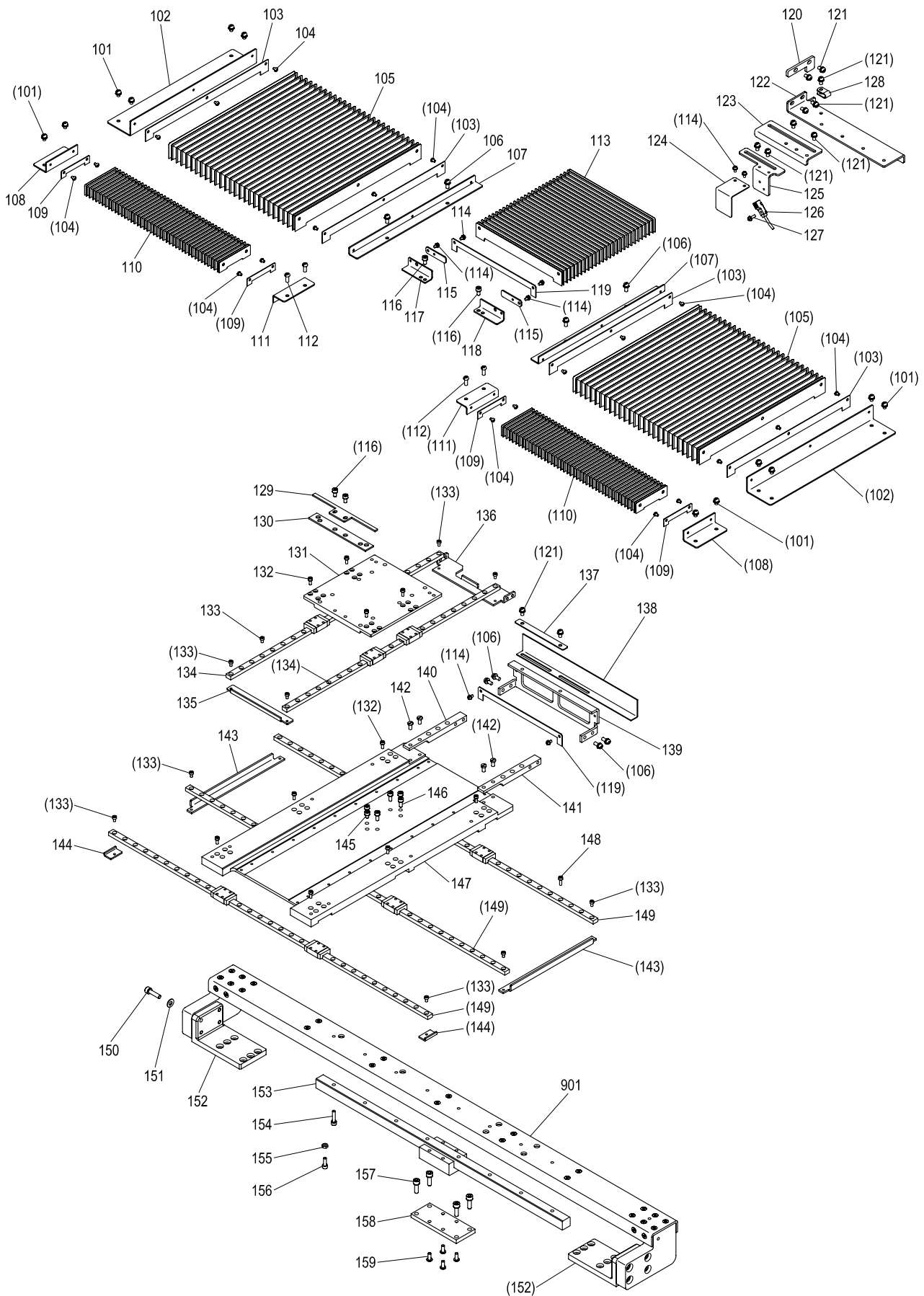

[K]X-Yテーブル機構(1)  
WORK HOLDER MECHANISM(1)

Fig no.	変更 Mod.	部品コード Parts no.	品名	Description	数量	
					Amt. Req. 4030	6030
K 101		M91058004	SW-PWプラマイネヘネジ M4X6	Screw M4X8	12	12
K 102		MA60A0226	ジャバラトリツケイタ	Shutter adapter	2	2
K 103		MA60A1226	ジャバラトリツケイタ	Shutter adapter	4	4
K 104		M90810004	プラマイネヘネジ M3X4	Screw M3X4	10	10
K 105		MA35A2458	ジャバラ	Shutter	1	*
K 105		MA60A0458	ジャバラ	Shutter	*	1
K 106		M91056004	SW-PWプラマイネヘネジ M4X10	Screw M4X10	8	8
K 107		MA60A4226	ジャバラトリツケイタ	Shutter adapter	2	2
K 108		MA60A5226	ジャバラトリツケイタ	Shutter adapter	2	2
K 109		MA60A6226	ジャバラトリツケイタ	Shutter adapter	4	4
K 110		MA35A3458	ジャバラ	Shutter	1	*
K 110		ME60A0458	ジャバラ	Shutter	*	1
K 111		MA60A7226	ジャバラトリツケイタ	Shutter adapter	2	2
K 112		M91010004	プラマイネヘネジ M4X10	Screw M4X10	4	4
K 113		MA35A0458	ジャバラ	Shutter	1	1
K 114		M90859004	SW-PWプラマイネヘネジ M3X6	Screw M3X6	8	8
K 115		MA35B0601	トリツケイタ	Adapter	2	2
K 116		M94002017	セフティソケット M4X8	Bolt M4X8	6	6
K 117		MB65A0228	ジャバラトリツケイタ	Shutter adapter	1	1
K 118		MA60A3226	ジャバラトリツケイタ	Shutter adapter	1	1
K 119		MA35A4601	ジャバラトリツケイタ	Shutter adapter	2	2
K 120		ME40A0196	イチキメイト	Guide plate	1	1
K 121		M91054004	SW-PWプラマイネヘネジ M4X8	Screw M4X8	11	11
K 122		ME40A2601	ケンシュツキトリツケイタ	Detector adapter	1	1
K 123		ME40A3601	ケンシュツキトリツケイタ	Detector adapter	1	1
K 124		ME40A0339	カバー	Cover	1	1
K 125		ME40A4601	ケンシュツキトリツケイタ	Detector adapter	1	1
K 126		ME20A0484	キンセツスイッチ X	Detector X	1	1
K 127		M90971004	SW-PWプラマイネヘネジ M3X10	Screw M3X10	1	1
K 128		M94003099	ナイロンクリップ AB-3N	Nylon clip AB-3N	1	1
K 129		MA35A1361	イチキメイト	Guide plate	1	1
K 130		MA60A1476	スパーサ	Spacer	1	1
K 131		MA60A0957	Yジクタイトウレース	Y movable race	1	1
K 132		M94012017	セフティソケット M3X8	Bolt M3X8	40	40
K 133		M93004021	ロッカクアナツキボルト M3X5	Bolt M3X5	32	32
K 134		MA35B1920	スライドガイド	Slide guide	2	2
K 135		MA35A1477	Yジクストッパ	Y stoper	1	1
K 136		ME40A0477	Yジクストッパ	Y stoper	1	1
K 137		ME40A0161	アテイタ	Plate	1	1
K 138		ME40A0407	Xケンシュツハン	X detector plate	1	*
K 138		ME60A0407	Xケンシュツハン	X detector plate	*	1
K 139		MB35A8601	ジャバラトリツケイタ	Shutter adapter	1	1
K 140		MA35A0602	トリツケイタ	Adapter	1	1
K 141		MA35A1602	トリツケイタ	Adapter	1	1
K 142		M90990002	ピラネジ M4X8	Screw M4X8	4	4
K 143		MA60A0477	Xジクストッパ	X stoper	2	*
K 143		ME40A1477	Xジクストッパ	X stoper	*	2
K 144		MA35A3477	Xジクストッパ	X stoper	2	*
K 144		ME60A1477	Xジクストッパ	X stoper	*	2
K 145		M94008017	セフティソケット M4X6	Bolt M4X6	2	2
K 146		M94001017	セフティソケット M4X10	Bolt M4X10	4	4
K 147		MB35A0957	Xジクタイトウレース	X movable race	1	1
K 148		M94005017	セフティソケット M3X10	Bolt M3X10	42	60
K 149		MA35B0920	スライドガイド	Slide guide	3	*
K 149		MA60A6920	スライドガイド	Slide guide	*	3
K 150		M95001017	セフティソケット M5X20	Bolt M5X20	8	8
K 151		M90511050	ザカネ 5	Washer 5	8	8
K 152		MA35A9603	ガイドトリツケイタ	Bracket	2	2
K 153		MA36A1920	スライドガイド	Slide guide	1	*
K 153		MA60A5920	スライドガイド	Slide guide	*	1
K 154		M94018017	セフティソケット M4X18	Bolt M4X18	8	12
K 155		M91007045	ナット M4	Nut M4	2	2
K 156		M94003021	ロッカクアナツキボルト M4X12	Bolt M4X12	2	2
K 157		M95015017	セフティソケット M5X16	Bolt M5X16	4	4
K 158		MB35A6601	トリツケイタ	Linear way adapter	1	1
K 159		M94039021	ロッカクアナツキボルト M4X10	Bolt M4X10	4	4
K 901		ME40A0200	Yイトウタイ	Y axis cradle	1	*
K 901		ME60A0200	Yイトウタイ	Y axis cradle	*	1

L X-Yテーブル機構(2)  
 X-Y TABLE MECHANISM(2)

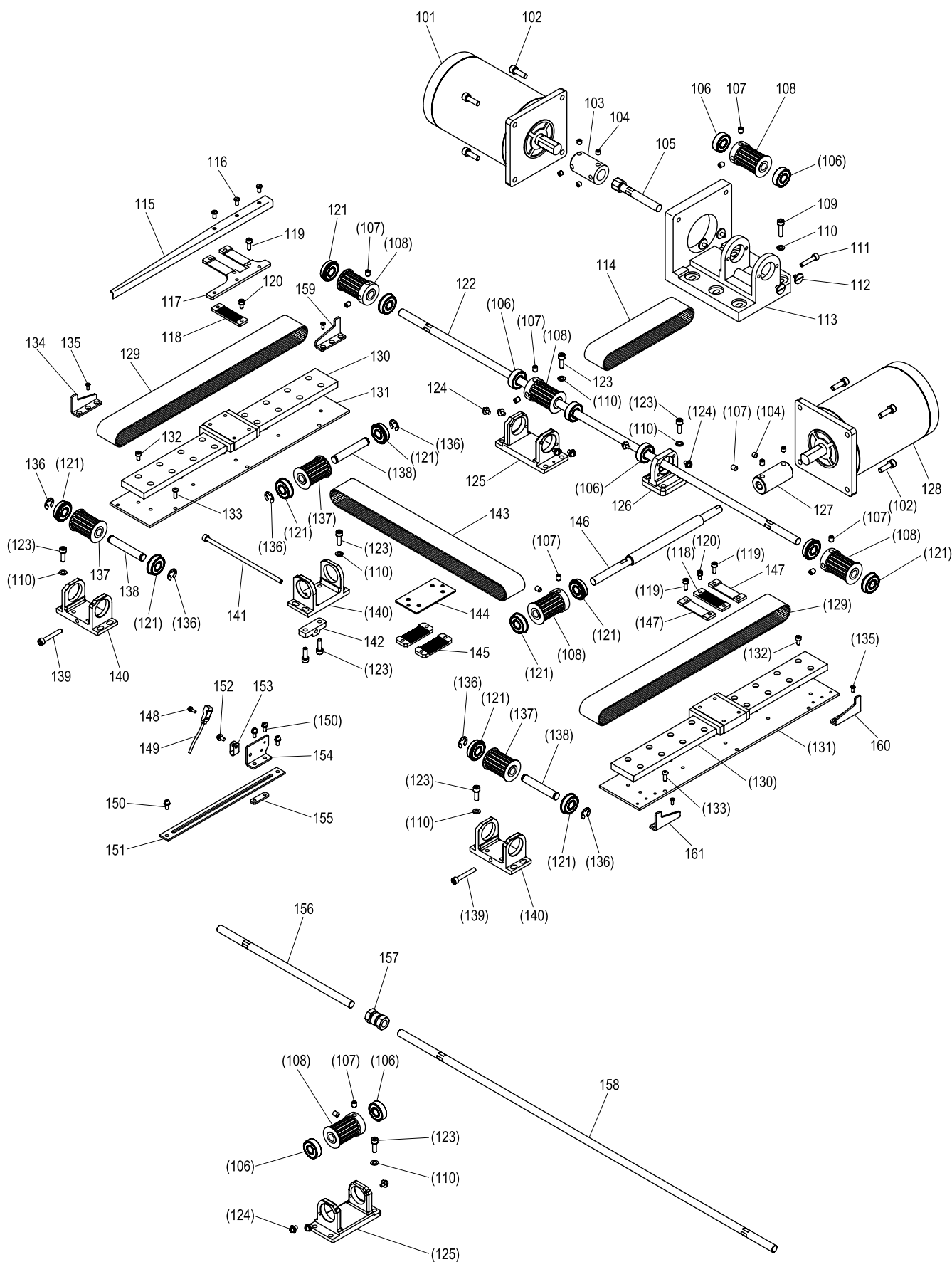

[L]X-Yテーブル機構(2)  
WORK HOLDER MECHANISM(2)

Fig no.	変更 Mod.	部品コード Parts no.	品名	Description	数量	
					Amt. Req. 4030	6030
L 101		M95050095	ステッピングモータ Y	Stepping motor Y	1	*
L 101		M95052095	ステッピングモータ Y	Stepping motor Y	*	1
L 102		M96006017	セフティソケット M6X20	Bolt M6X20	8	8
L 103		MB35A0571	ジクツキテ	Sleeve	1	1
L 104		M96002001	トメネジ M6X6	Screw M6X6	6	6
L 105		MB35A0390	Yクトウシク	Driving shaft Y	1	1
L 106		MS02A2456	ベアリング	Ball bearing	5	7
L 107		M96001001	トメネジ M6X8	Screw M6X8	12	12
L 108		MB45A0767	タイミングプーリ	Cog pulley	4	4
L 109		M95016017	セフティソケット M5X20	Bolt M5X20	4	4
L 110		M90512050	ワッシャ 5	Washer 5	24	28
L 111		M95011021	ロックアナツキホルト M5X25	Bolt M5X25	1	1
L 112		M91119002	ヒラネジ 11/64(40)X6.8	Screw 11/64(40)X6.8	4	4
L 113		MA60A3603	モータリツケダイ	Motor bracket	1	1
L 114		MB35A1523	タイミングベルト	Cog belt	1	1
L 115		ME40A1407	Y検出シツパン	Y detector plate	1	1
L 116		M90992002	ヒラネジ M4X8	Screw M4X8	3	3
L 117		ME40A0476	スペーサ	Spacer	1	1
L 118		ME40A0778	ベルトオサエ	Belt clamper	2	2
L 119		M94007017	セフティソケット M4X12	Bolt M4X12	8	8
L 120		M94002017	セフティソケット M4X8	Bolt M4X8	4	4
L 121		MB62A0456	ベアリング	Ball bearing	12	10
L 122		MA35A2390	Yクトウシク	Driving shaft Y	1	1
L 123		M95004017	セフティソケット M5X16	Bolt M5X16	22	26
L 124		M91071004	SW-MWプラマイナネジ M4X8	Screw M4X8	8	12
L 125		MA30A0758	ブラケット	Bracket	1	2
L 126		MA35A1758	ブラケット	Bracket	1	1
L 127		MB35A1571	ジクツキテ	Sleeve	1	1
L 128		M95049095	ステッピングモータ X	Stepping motor X	1	*
L 128		M95051095	ステッピングモータ X	Stepping motor X	*	1
L 129		MA35A0523	タイミングベルト	Cog belt	2	2
L 130	A	ME40A0920	スライドガイド	Slide guide	2	2
L 131	A	ME40A7601	ガイドリツケイタ	Linear way adapter	2	2
L 132		M95018021	ロックアナツキホルト M4X8	Bolt M4X8	20	20
L 133		M94017021	ロックアナツキホルト M4X12	Bolt M4X12	12	12
L 134	A	ME40A3477	ストッパ	Stopper	1	1
L 135	A	M9130410	Pサラネジ M3 X 6	Screw M3 X 6	16	16
L 136		M90604065	E括トメワ 8	E-type retaining ring 8	6	6
L 137		MB62A0767	タイミングプーリ	Cog pulley	3	3
L 138		MA21P0454	シク	Shaft	3	3
L 139		M95008021	ロックアナツキホルト M5X35	Bolt M5X35	2	2
L 140		ME40A1758	ブラケット	Bracket	3	3
L 141		M95044021	ロックアナツキホルト M5X140	Bolt M5X140	1	*
L 141		M95050021	ロックアナツキホルト M5X60	Bolt M5X60	*	1
L 142		MA35A0564	チョウセツダイ	Bracket	1	1
L 143		MB35A0523	タイミングベルト	Cog belt	1	1
L 144		ME40A1476	スペーサ	Spacer	1	1
L 145		MA35A1781	ベルトオサエ	Belt clamper	2	2
L 146		MA60A0390	Xクトウシク	Driving shaft X	1	1
L 147		MB35A0476	スペーサ	Spacer	2	2
L 148		M90971004	SW-PWプラマイナネジ M3X10	Screw M3X10	1	1
L 149		ME40A0484	キンセツスイツチ Y	Detector Y	1	1
L 150		M91056004	SW-PWプラマイナネジ M4X10	Screw M4X10	4	4
L 151		MB35A3601	ケンシツキトリツケイタ	Detector adapter	1	1
L 152		M91054004	SW-PWプラマイナネジ M4X8	Screw M4X8	1	1
L 153		M94003099	ナイロンクリップ AB-3N	Nylon clip AB-3N	1	1
L 154		ME40A5601	ケンシツキトリツケイタ	Detector adapter	1	1
L 155		MB35A0639	ネジイタ	Adapter	1	1
L 156		MB65A0390	Yクトウシク	Driving shaft Y	*	1
L 157		MA30A0364	カップリング	Coupling	*	1
L 158		MA60A1390	Yクトウシク	Driving shaft Y	*	1
L 159	A	ME40A3477	ストッパ C	Stopper C	1	1
L 160	A	ME40A4477	ストッパ D	Stopper D	1	1
L 161	A	ME40A2477	ストッパ A	Stopper A	1	1

**M** 外押え機構  
 WORK HOLDER MECHANISM

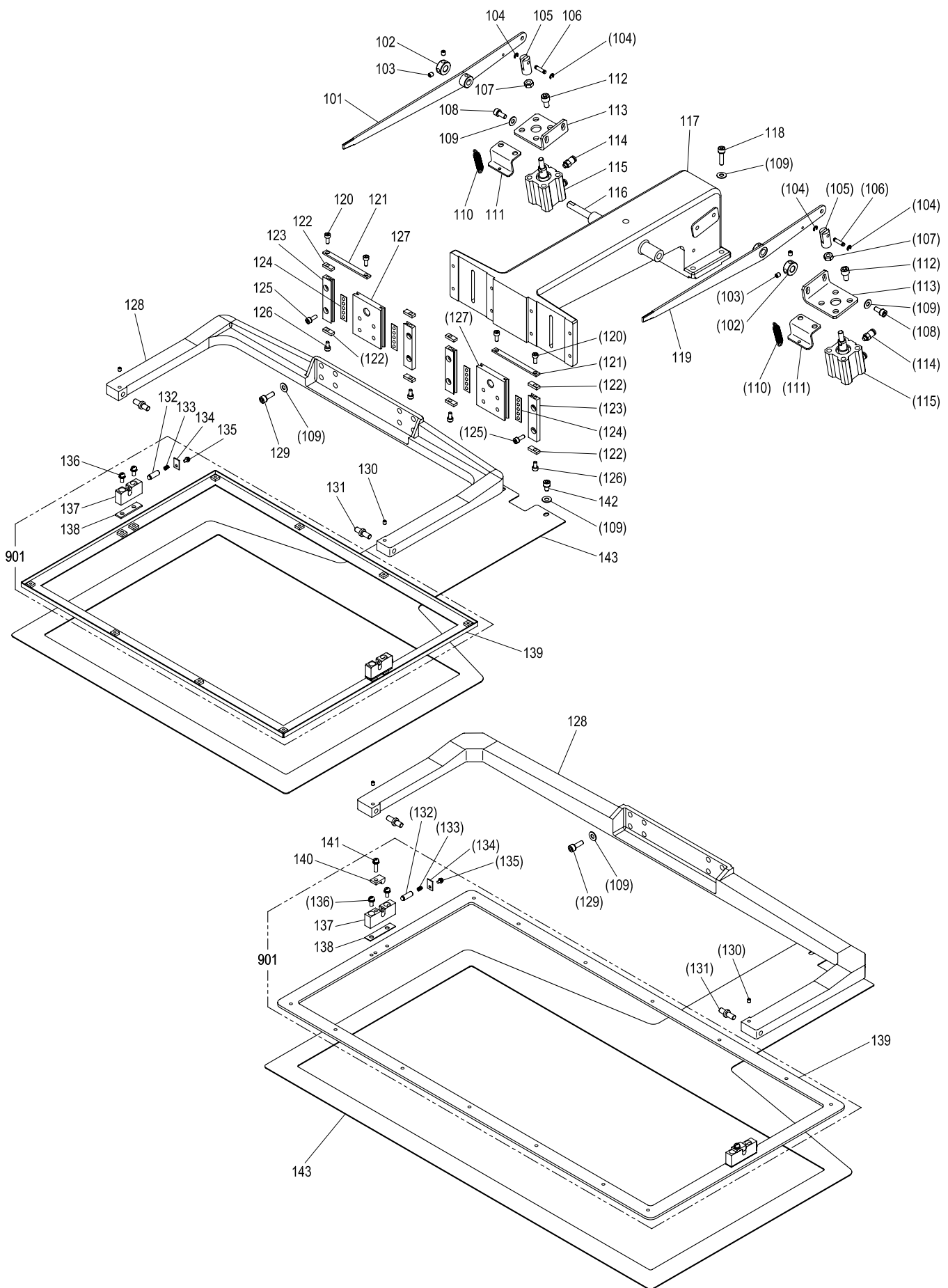



[M]外押え機構

WORK HOLDER MECHANISM

Fig no.	変更 Mod.	部品コード Parts no.	品名	Description	数量	
					Amt. Req. 4030	6030
M 101		MA35A2950	オサエレバ L	Pushing lever L	1	1
M 102		MS02A1352	カラー	Collar	2	2
M 103		M95002020	ロッカクアナツキトメネジ M5X6	Screw M5X6	4	4
M 104		M90512065	Eガトメワ 3	E-type retaining ring 3	4	4
M 105		MA35A0621	ナックル	Knuckle	2	2
M 106		M97011060	ピン	Pin	2	2
M 107		M91576045	ナット M6	Nut M6	2	2
M 108		M95002017	セフティソケット M5X12	Bolt M5X12	4	4
M 109		M90511050	ワッシャ 5	Washer 5	18	18
M 110		MA35A3572	ツルマキハネ	Spring	2	*
M 111		MS35A2708	ハネカケ	Hook	2	*
M 112		M96002017	セフティソケット M6X12	Bolt M6X12	8	8
M 113		MA20B1601	トリツケイタ	Adapter	2	2
M 114		MA20A9571	ワンタッチツギテ	Connector	2	2
M 115		MA20A2434	エアシリンダ	Air cylinder	2	2
M 116		MA35A0454	シク	Shaft	1	1
M 117		MA35A0308	オサエダイ	Clamp bracket	1	1
M 118		M95001017	セフティソケット M5X20	Bolt M5X20	4	4
M 119		MA35A4950	オサエレバ R	Pushing lever R	1	1
M 120		M91060021	ロッカクアナツキホルト M4X10	Bolt M4X10	4	4
M 121		MA35A2477	ストッパ	Stopper	2	2
M 122		MS13A2477	ストッパ	Stopper	8	8
M 123		MA22A0957	オサエコテイレース	Fixed race	4	4
M 124		M94008070	ローラーケージ	Roller cage	4	4
M 125		M94007017	セフティソケット M4X12	Bolt M4X12	8	8
M 126		M95018021	ロッカクアナツキホルト M4X8	Bolt M4X8	4	4
M 127		MB45A1957	オサエイトウレース	Movable race	2	2
M 128		MA36A0273	オサエウデ	Clamp adapter	1	*
M 128		MA60A0273	オサエウデ	Clamp adapter	*	1
M 129		M95004017	セフティソケット M5X16	Bolt M5X16	8	8
M 130		M91050020	ロッカクアナツキトメネジ M4X5	Screw M4X5	2	2
M 131		ME10A0454	オサエシク	Clamp stud	2	2
M 132		M90611060	ピン	Pin	2	2
M 133		MS13A0572	コイルハネ	Spring	2	2
M 134		MS02B0257	オサエイタ	Adapter	2	2
M 135		M90859004	SW-PWフライマナハネネジ M3X6	Screw M3X6	2	2
M 136		M91056004	SW-PWフライマナハネネジ M4X10	Screw M4X10	4	4
M 137		ME40A0426	ササエ	Supporter	2	*
M 137		MA45A7426	ササエ	Supporter	*	2
M 138		MA25A1476	スぺーサ	Spacer	2	*
M 138		MB65A0476	スぺーサ	Spacer	*	2
M 139		MA36A0105	ソトオサエイタ	Clamp frame	1	*
M 139		MA60A0105	ソトオサエイタ	Clamp frame	*	1
M 140		MA45A2196	セットイタ	Set plate	*	2
M 141		M91073004	SW-PWフライマナハネネジ M4X16	Screw M4X16	*	2
M 142		M95003017	セフティソケット M5X8	Bolt M5X8	2	2
M 143		MA36A0272	シタオサエイタ	Feed plate	1	*
M 143		MA60A0272	シタオサエイタ	Feed plate	*	1
M 901		MA36E0105	ソトオサエクミ	Clamp frame assy	1	*
M 902		MA60E0105	ソトオサエクミ	Clamp frame assy	*	1

**N** ワイパー機構  
WIPER MECHANISM

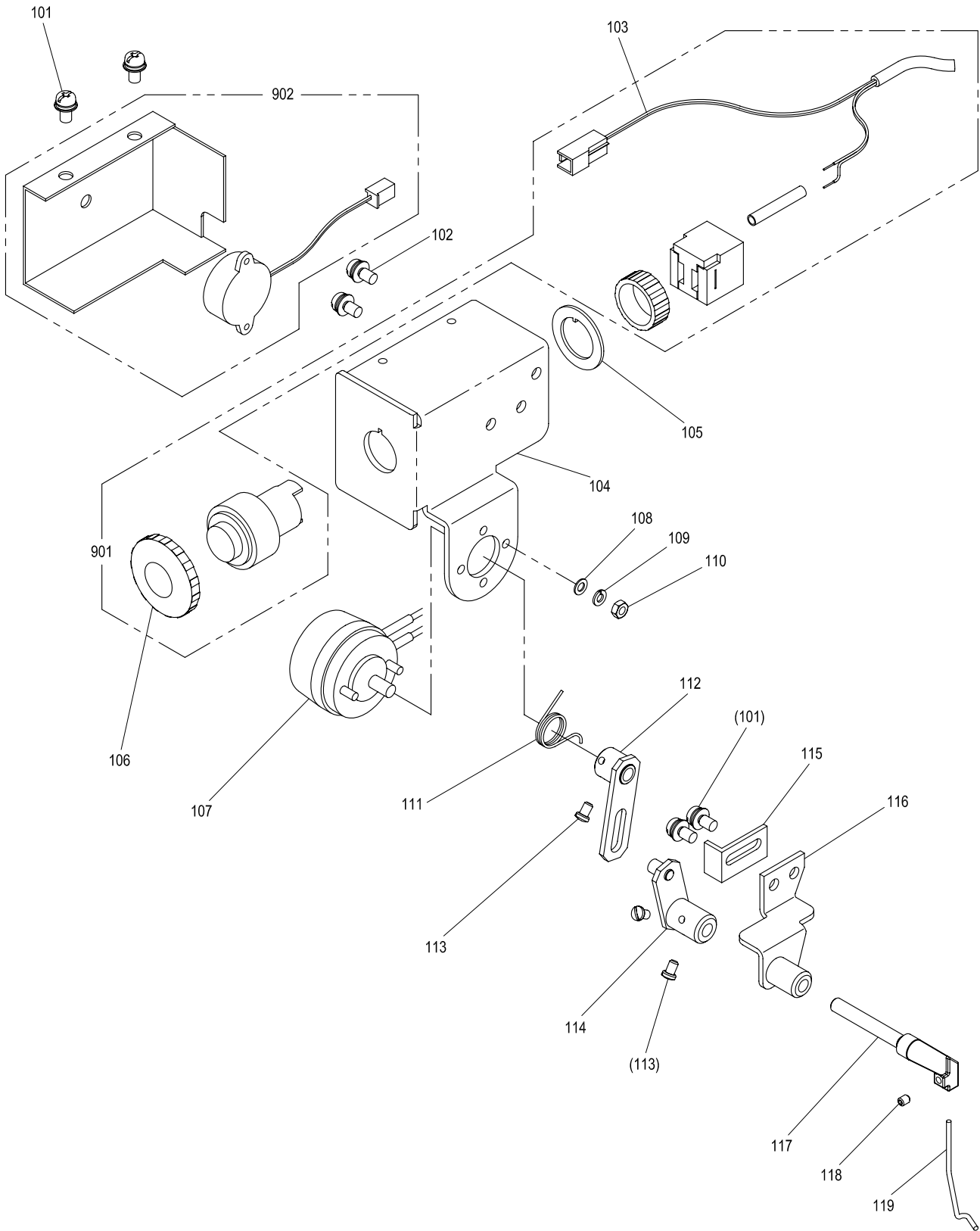

[N]ワイパー機構  
WIPER MECHANISM

Fig no.	変更 Mod.	部品コード Parts no.	品名	Description	数量	
					Amt. 4030	Req. 6030
N 101		M91054004	SW-PW <sup>ラ</sup> マイナ <sup>ベ</sup> ネジ <sup> M4X8</sup> .....	Screw M4X8.....	4	4
N 102		M91056004	SW-PW <sup>ラ</sup> マイナ <sup>ベ</sup> ネジ <sup> M4X10</sup> .....	Screw M4X10.....	2	2
N 103		ME40A0508	セツク <sup>テ</sup> ンセン.....	Cable (stop BZ).....	1	1
N 104		ME10E3601	トリツケ <sup>イ</sup> タ.....	Bracket.....	1	1
N 105		MB60A0915	ロック <sup>リ</sup> ング.....	Lock ring.....	1	1
N 106		ME03A0270	プッシュ <sup>ホ</sup> タン.....	Push button.....	1	1
N 107		ME40E2519	ワイパ <sup>ー</sup> ソレノ <sup>イ</sup> ド.....	Solenoid (wiper).....	1	1
N 108		M90317050	サ <sup>カ</sup> ネ 3.....	Washer 3.....	2	2
N 109		M90307053	ハ <sup>ネ</sup> サ <sup>カ</sup> ネ 3.....	Spring washer 3.....	2	2
N 110		M90875045	ナット M3.....	Nut M3.....	2	2
N 111		MS02A4729	ヒネ <sup>リ</sup> ハ <sup>ネ</sup> .....	Spring.....	1	1
N 112		MS02E0983	ク <sup>ト</sup> ウ <sup>イ</sup> タ.....	Wiper crank 1.....	1	1
N 113		M90802003	マル <sup>ヒ</sup> ラ <sup>ネ</sup> ジ <sup> 1/8(44)X4.5</sup> .....	Screw 1/8(44)X4.5.....	4	4
N 114		MS03E0981	ジュ <sup>ウ</sup> ト <sup>ウ</sup> イ <sup>タ</sup> .....	Wiper crank 2.....	1	1
N 115		MS02A1477	ストップ <sup>パ</sup> .....	Stopper.....	1	1
N 116		MB60E0982	ワイパ <sup>ー</sup> ダ <sup>イ</sup> .....	Wiper adapter.....	1	1
N 117		MS03A1530	ワイパ <sup>ー</sup> ジ <sup>ク</sup> .....	Wiper shaft.....	1	1
N 118		M91057020	ロック <sup>カ</sup> ア <sup>ナ</sup> ツ <sup>キ</sup> ト <sup>メ</sup> ネ <sup>ジ</sup> M3X4.....	Screw M3X4.....	1	1
N 119		MS03A3980	ワイパ <sup>ー</sup> .....	Wiper.....	1	1
N 901		ME40E0270	オン <sup>ホ</sup> タン <sup>ス</sup> イ <sup>ツ</sup> チ <sup>ク</sup> ミ.....	Switch assy.....	1	1
N 902		MB60E3339	カ <sup>ハ</sup> ク <sup>ミ</sup> (フ <sup>サ</sup> ー <sup>ツ</sup> キ).....	Cover assy (with buzzer).....	1	1

**P** 給油機構  
OIL LUBRICATION MECHANISM

---

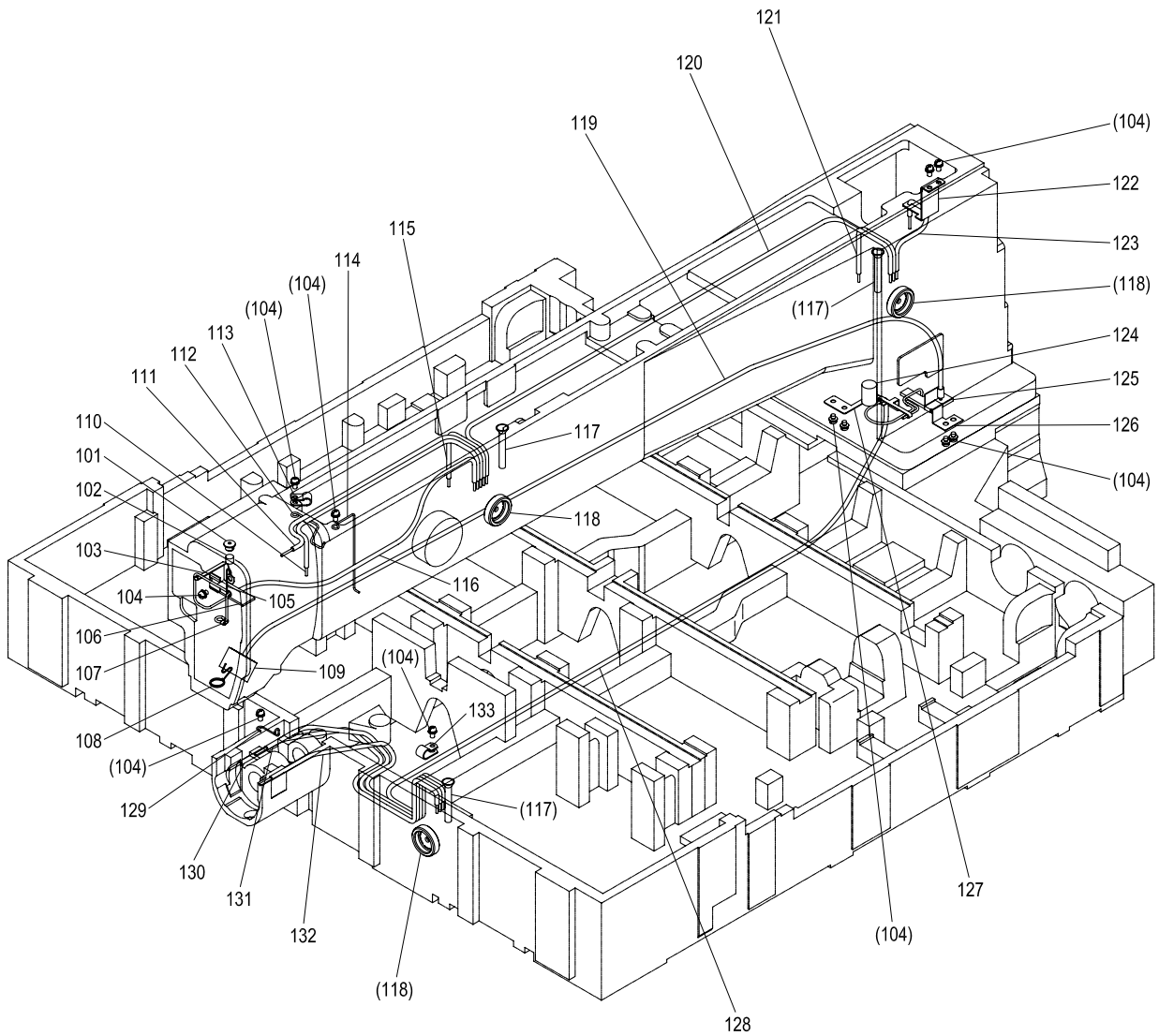

[P]給油機構

OIL LUBRICATION MECHANISM

Fig no.	変更 Mod.	部品コード Parts no.	品 名	Description	数量	
					Amt. Req. 4030	6030
P 101	MF60A0742		フタ	Cap	1	1
P 102	MF10A2740		フェルト	Felt	1	1
P 103	ME10A1780		ホルダ	Holder	1	1
P 104	M91054004		SW-PWフライナネジ M4X8	Screw M4X8	11	11
P 105	MS03A2780		ホルダ	Holder	1	1
P 106	MS01A1740		フェルト	Felt	1	1
P 107	MF80A0780		ホルダ	Holder	1	1
P 108	MF00A2780		ホルダ	Holder	1	1
P 109	MS08A0740		フェルト	Felt	1	1
P 110	ME40E9688		パイプヒモクミ (ヘンシンリン)	Oil pipe assy (eccentric cam)	1	1
P 111	ME40E7688		パイプヒモクミ (ウワシクメタル マエ)	Oil pipe assy (drive shaft bushing F)	1	1
P 112	MA20A1780		ホルダ	Holder	1	1
P 113	M94004099		ナイロンクリップ AB-4N	Nylon clip AB-4N	1	1
P 114	MS10A0780		ホルダ	Holder	1	1
P 115	ME40F1688		パイプヒモクミ (ウワシクメタル ナカ)	Oil pipe assy (drive shaft bushing C)	1	1
P 116	ME40E6688		パイプヒモクミ (ハリホウ)	Oil pipe assy (needle bar)	1	1
P 117	MA20A6688		パイプ (アルミ)	Pipe	3	3
P 118	MN10A0135		オイルゲージ	Oil gauge	3	3
P 119	ME40E4688		パイプヒモクミ (カンユ)	Oil pipe assy (circulation)	1	1
P 120	ME40F0688		パイプヒモクミ (タンク)	Oil pipe assy (tank)	1	1
P 121	ME40E8688		パイプヒモクミ (ウワシクメタル ウシロ)	Oil pipe assy (drive shaft bushing R)	1	1
P 122	MB60A1780		ホルダ	Holder	1	1
P 123	ME40E3688		パイプヒモクミ (レンゼツカン)	Oil pipe assy (connecting rod)	1	1
P 124	MF60A5740		フェルト	Felt	1	1
P 125	MS14A0740		フェルト	Felt	1	1
P 126	MS01A9796		ホルダ	Holder	1	1
P 127	MS14A3780		ホルダ	Holder	1	1
P 128	ME40E5688		パイプヒモクミ (シタシクメタル ウシロ)	Oil pipe assy (hook shaft bushing R)	1	1
P 129	MS01A8796		ホルダ	Holder	1	1
P 130	ME40E1688		パイプヒモクミ (カマ ヒダリ)	Oil pipe assy (hook left)	1	1
P 131	ME40E2688		パイプヒモクミ (カマ ナカ)	Oil pipe assy (hook center)	1	1
P 132	ME40E0688		パイプヒモクミ (カマ ミキ)	Oil pipe assy (hook right)	1	1
P 133	MN60A0620		ナイロンクリップ AB-5N	Nylon clip AB-5N	1	1

Q 配線・配管関係  
 CABLE COMPONENT & PNEUMATIC CONTROL UNIT

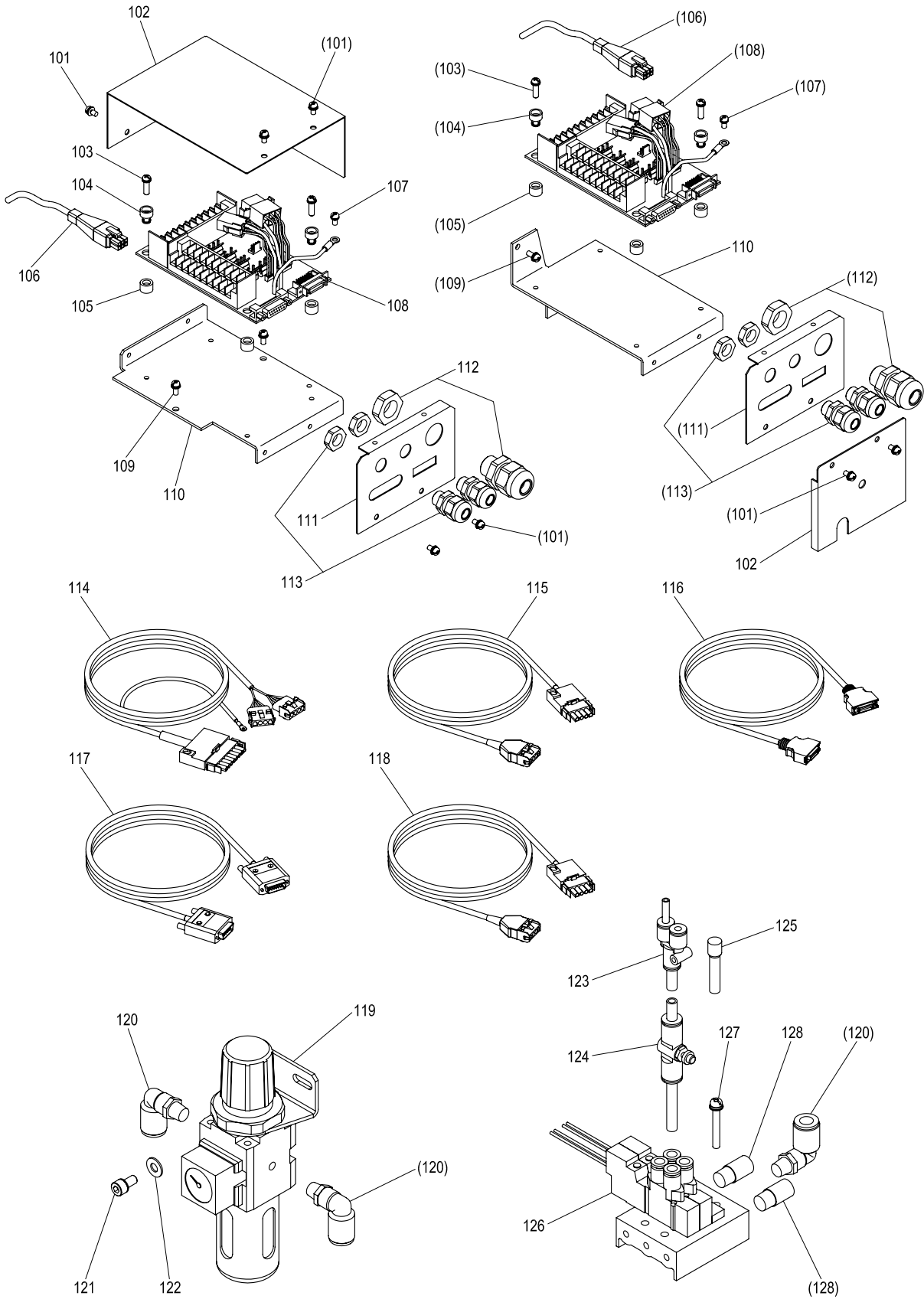

[Q]配線・配管関係

CABLE COMPONENT & PNEUMATIC CONTROL UNIT

Fig no.	変更 Mod.	部品コード Parts no.	品名	Description	数量	
					Amt. Req. 4030	6030
Q 101		M91071004	SW-MWフライナネジ M4X8	Screw M4X8	6	2
Q 102		MB35A0339	Pハンカバ	Circuit board cover	1	*
Q 102		ME40A1339	Pハンカバ	Circuit board cover	*	1
Q 103		M91073004	SW-PWフライナネジ M4X16	Screw M4X16	4	4
Q 104		MB60A0366	ワタツチブッシュ	Nylon bush	4	4
Q 105		MB60A2352	ワタツチブッシュ	Nylon bush	4	4
Q 106		K14M71725402	ケーブル (エンコーダ)	Cable (Encoder)	1	1
Q 107		M90439037	SWフライナネジ M4X8	Screw M4X8	1	1
Q 108		M800E1CON	Pハンクミタテ PLK-E-CON	Print circuit board	1	1
Q 109		M91056004	SW-PWフライナネジ M4X10	Screw M4X10	2	2
Q 110		MB35A7601	Pハントリツケイタ	Circuit board bracket	1	*
Q 110		MB65A0601	Pハントリツケイタ	Circuit board bracket	*	1
Q 111		MB60A5601	コネクタトリツケイタ	Connector panel	1	1
Q 112		MB60A5780	コードブッシュ 大	Cord bushing (large)	1	1
Q 113		MB60A6780	コードブッシュ 小	Cord bushing (small)	2	2
Q 114		M97321099	ケーブル (ステッピングモータ)	Cable (stepping motor)	1	1
Q 115		ME40A1508	ケーブル (ステッピングモータエンチャウヨウ)	Cable (stepping motor extension)	1	1
Q 116		M97319099	ケーブル (ニューリヨクシンコウ)	Cable (input signal)	1	1
Q 117		M97320099	ケーブル (ソレノイド)	Cable (solenoid)	1	1
Q 118		M97318099	ケーブル (サーボモータデンゲン)	Cable (servo motor)	1	1
Q 119		MB61A0963	フィルタレギュレータ	Filter regulator	1	1
Q 120		MA20A8571	Lガタツキテ	L-type quick joint	3	3
Q 121		M95005017	セフティソケット M5X10	Bolt M5X10	2	2
Q 122		M90511050	ワッシャ 5	Washer 5	2	2
Q 123		MA20A6571	イケイユニオン Y	Y-type quick joint	1	2
Q 124		MA16A0495	スピードコントローラ	Speed controller	1	2
Q 125		MB62A0757	プラグ	Plug	1	*
Q 125		MB45E0599	デンジハンクミタテ	Solenoid valve complete	1	1
Q 126		M91276004	SW-PWフライナネジ M4X30	Screw M4X30	4	4
Q 127		M91035089	サイレンサ	Muffler	2	2

**R** テーブル関係  
TABLE & STAND

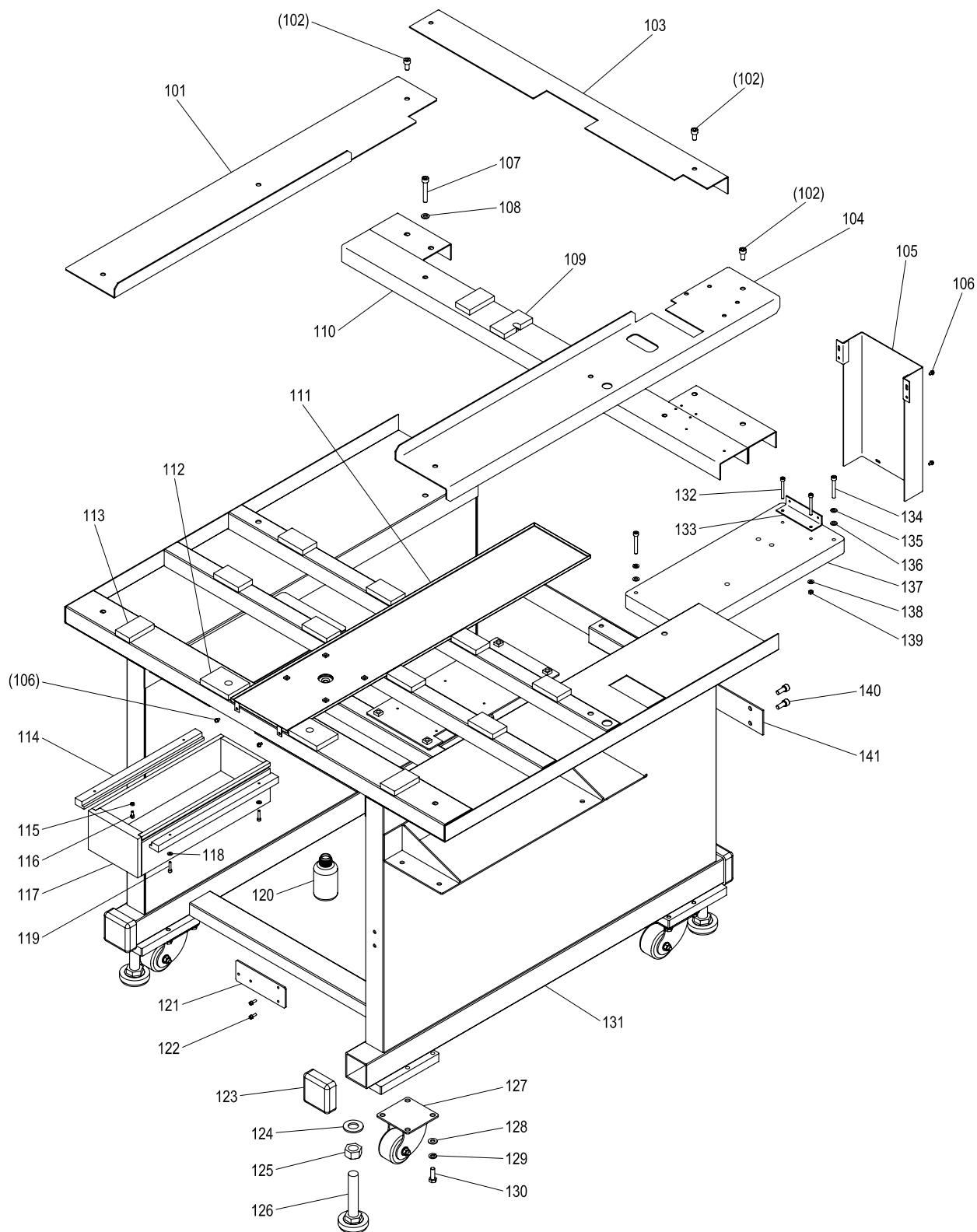



[R]テーブル関係  
TABLE & STAND

Fig no.	変更 Mod.	部品コード Parts no.	品名	Description	数量	
					Amt. Req. 4030	6030
R 101		MB35A2339	キャクカハ <sup>ン</sup> (ヒダ <sup>リ</sup> )	Table cover (left)	1	1
R 102		M98001021	ロックアナツキボルト M8X16	Bolt M8X16	8	8
R 103		MA35A3339	キャクカハ <sup>ン</sup> (ウシロ)	Table cover (rear)	1	*
R 103		MA65A0339	キャクカハ <sup>ン</sup> (ウシロ)	Table cover (rear)	*	1
R 104		ME40A2339	キャクカハ <sup>ン</sup> (ミキ)	Table cover (right)	1	*
R 104		ME60A1339	キャクカハ <sup>ン</sup> (ミキ)	Table cover (right)	*	1
R 105		ME40A0776	ベルトカハ <sup>ン</sup>	Belt cover	1	1
R 106		M91054004	SW-PW <sup>ラ</sup> マイナ <sup>ハ</sup> ネシ <sup>ン</sup> M4X8	Screw M4X8	6	6
R 107		M98015021	ロックアナツキボルト M8X50	Bolt M8X50	2	2
R 108		M90803053	ハ <sup>ネ</sup> サ <sup>ガ</sup> ネ 8	Spring washer 8	2	2
R 109		ME40A1419	ホ <sup>ウ</sup> シ <sup>ン</sup> ゴ <sup>ム</sup>	Rubber cushion	2	2
R 110		MB35A0429	サ <sup>サ</sup> エ <sup>ダ</sup> イ	Adapter	1	*
R 110		MB65A0429	サ <sup>サ</sup> エ <sup>ダ</sup> イ	Adapter	*	1
R 111		MB35A0139	オイルパ <sup>ン</sup>	Oil pan	1	1
R 112		ME40A2419	ホ <sup>ウ</sup> シ <sup>ン</sup> ゴ <sup>ム</sup>	Rubber cushion	2	2
R 113		MA35A1419	ホ <sup>ウ</sup> シ <sup>ン</sup> ゴ <sup>ム</sup>	Rubber cushion	11	11
R 114		MB60A3957	レール	Rail	2	2
R 115		M91007045	ナット M4	Nut M4	1	1
R 116		M94001017	セフティソケット M4X10	Bolt M4X10	1	1
R 117		MA20A0719	ヒキタ <sup>シ</sup>	Drawer	1	1
R 118		M90421050	サ <sup>ガ</sup> ネ 4	Washer 4	4	4
R 119		M94015021	ロックアナツキボルト M4X20	Bolt M4X20	4	4
R 120		MF20A0130	ア <sup>ブ</sup> ラ <sup>ビ</sup> ン	Oil bottle	1	1
R 121		MB45A6601	レキ <sup>ュ</sup> レ <sup>ー</sup> タ <sup>リ</sup> ツケ <sup>イ</sup> タ	Adapter	1	1
R 122		M94007017	セフティソケット M4X12	Bolt M4X12	2	2
R 123		MB45A0150	ゴ <sup>ム</sup> キヤ <sup>ク</sup>	Top cap	4	4
R 124		M92002050	サ <sup>ガ</sup> ネ 20	Washer 20	4	4
R 125		M95021045	ナット M20	Nut M20	4	4
R 126		MA35A0166	ア <sup>ン</sup> ジャ <sup>ス</sup> タ <sup>フ</sup> ツ	Ajutor	4	4
R 127		ME40A0368	キャ <sup>ス</sup> タ <sup>ー</sup>	Castor	4	4
R 128		M90824050	サ <sup>ガ</sup> ネ 8	Washer 8	16	16
R 129		M90825053	ハ <sup>ネ</sup> サ <sup>ガ</sup> ネ 8	Spring washer 8	16	16
R 130		M98011021	ロックボルト M8X25	Bolt M8X25	16	16
R 131		ME40E0150	キャククミタ <sup>テ</sup>	Table	1	*
R 131		ME60E0150	キャククミタ <sup>テ</sup>	Table	*	1
R 132		M95035021	ロックアナツキボルト M5X45	Bolt M5X45	2	2
R 133		MA35B7601	ベルトカハ <sup>ン</sup> トリツケ <sup>イ</sup> タ	Belt cover adapter	1	1
R 134		M96016021	ロックアナツキボルト M6X45	Bolt M6X45	4	4
R 135		M90624053	ハ <sup>ネ</sup> サ <sup>ガ</sup> ネ 6	Spring washer 6	4	4
R 136		M90631050	サ <sup>ガ</sup> ネ 6	Washer 6	4	4
R 137		MA35B8601	モ <sup>ー</sup> タ <sup>リ</sup> ツケ <sup>イ</sup> タ	Motor adapter	1	1
R 138		M90511050	サ <sup>ガ</sup> ネ 5	Washer 5	2	2
R 139		M91382045	ナット M5	Nut M5	2	2
R 140		M98004017	セフティソケット M8X20	Bolt M8X20	4	4
R 141		ME40A6601	モ <sup>ー</sup> タ <sup>リ</sup> ツケ <sup>イ</sup> タ	Motor adapter	1	*
R 141		ME60A0601	モ <sup>ー</sup> タ <sup>リ</sup> ツケ <sup>イ</sup> タ	Motor adapter	*	1

**S** 付属品  
ACCESSORIES

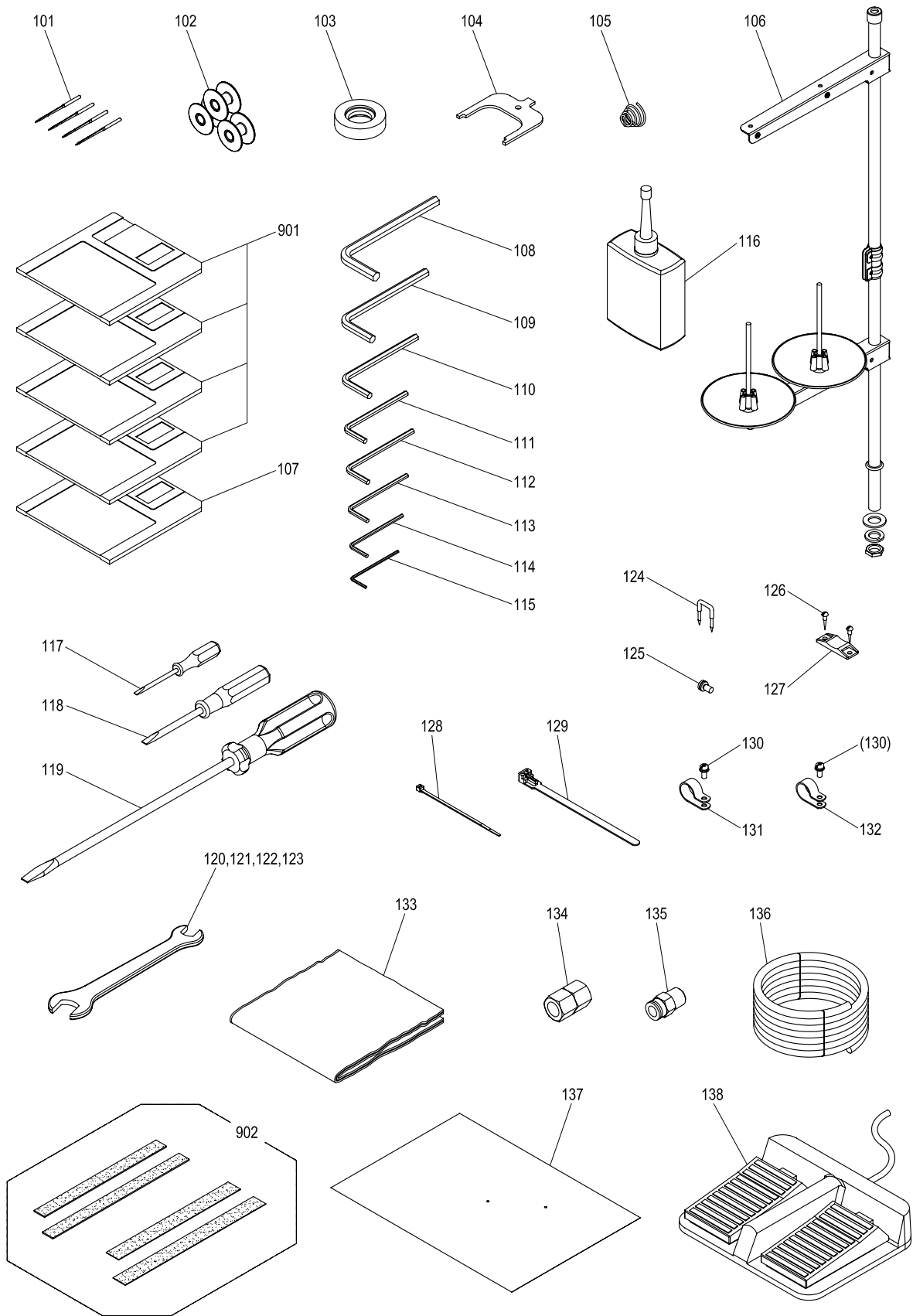

[S] 付属品  
ACCESSORIES

Fig no.	変更 Mod.	部品コード Parts no.	品 名	Description	数量	
					Amt. Req. 4030	6030
S 101	MS02A0128	MS02A0128	ミシンハリ DPX17#18	Needle DPX17#18	4	4
S 102	MA10A0123	MA10A0123	ホビン	Bobbin	3	3
S 103	MS03A0417	MS03A0417	ゴムワ (イトマキヨウ)	Tire (for bobbin winder)	1	1
S 104	MF01A0565	MF01A0565	カドチョウセイグ	Speed command disk adjusting plate	1	1
S 105	MN52A1245	MN52A1245	エンスイバネ	Tension spring	1	1
S 106	MF40E0193	MF40E0193	イタテダイクミタテ	Cotton stand assy	1	1
S 107	MB60A1990	MB60A1990	データフロッピーディスク	Pattern data F/D	1	1
S 108	MS05A1976	MS05A1976	ロッカクホウレンチ 6	Hexagonal wrench 6	1	1
S 109	MS05A0976	MS05A0976	ロッカクホウレンチ 5	Hexagonal wrench 5	1	1
S 110	MS01A1976	MS01A1976	ロッカクホウレンチ 4	Hexagonal wrench 4	1	1
S 111	MF90A0976	MF90A0976	ロッカクホウレンチ 1/8"	Hexagonal wrench 1/8"	1	1
S 112	MS02A2976	MS02A2976	ロッカクホウレンチ 3	Hexagonal wrench 3	1	1
S 113	MS02A1976	MS02A1976	ロッカクホウレンチ 2.5	Hexagonal wrench 2.5	1	1
S 114	MS02A0976	MS02A0976	ロッカクホウレンチ 2	Hexagonal wrench 2	1	1
S 115	MS10A0976	MS10A0976	ロッカクホウレンチ 1.5	Hexagonal wrench 1.5	1	1
S 116	MF10A0149	MF10A0149	アブラサシ	Oiler with oil	1	1
S 117	MB02A1608	MB02A1608	ドライバ (ショウ)	Screw driver (small)	1	1
S 118	MB02A0608	MB02A0608	ドライバ (チュウ)	Screw driver (middle)	1	1
S 119	MF00A0608	MF00A0608	ドライバ (ダイ)	Screw driver (large)	1	1
S 120	MS02A0479	MS02A0479	スパナ 13-17	Spanner 13-17	1	1
S 121	MM10A1479	MM10A1479	スパナ 10-14	Spanner 10-14	1	1
S 122	MS10A1976	MS10A1976	スパナ 8-9	Spanner 8-9	1	1
S 123	MS10A2976	MS10A2976	スパナ 6-7	Spanner 6-7	1	1
S 124	K14M95610701	K14M95610701	ステッフル	Staple	3	3
S 125	M90439037	M90439037	SWプラマイナヘネジ M4X8	Screw M4X8	1	1
S 126	M90306041	M90306041	マルモクネジ 3.1X16	Wooden screw 3.1X16	4	4
S 127	MB60A0420	MB60A0420	コタイク	Tie holder	2	2
S 128	MG51A0201	MG51A0201	ハインダ	Cord tie	1	1
S 129	MB60A0201	MB60A0201	ハインダ	Cord tie	2	2
S 130	M91056004	M91056004	SW-PWプラマイナヘネジ M4X10	Screw M4X10	2	2
S 131	MB60A2620	MB60A2620	ナイロンクリップ AB-10N	Nylon clip AB-10N	1	1
S 132	MB60A1620	MB60A1620	ナイロンクリップ AB-8N	Nylon clip AB-8N	1	1
S 133	MA20A0734	MA20A0734	ビニルカバー	Polyethylene cover	1	1
S 134	M91010089	M91010089	ロッカクソケット	Socket	1	1
S 135	MA30A0571	MA30A0571	ワンタッチツキテ	Quick joint	1	1
S 136	MS06A0567	MS06A0567	エアチューブ	Air tube	1	1
S 137	MA36A0797	MA36A0797	ホコフィルム	Film sheet	1	*
S 137	MA60A0797	MA60A0797	ホコフィルム	Film sheet	*	1
S 138	M860A0FSW	M860A0FSW	フットスイッチ	Foot switch	1	1
S 901	ME20E0990	ME20E0990	システムフロッピーディスク (4マイ)	System F/D (4discs)	1	1
S 902	ME40E0691	ME40E0691	ハッキンセット	Clamp pad set	1	*
S 902	ME60E0691	ME60E0691	ハッキンセット	Clamp pad set	*	1

T オプションパーツ  
OPTION PARTS

---

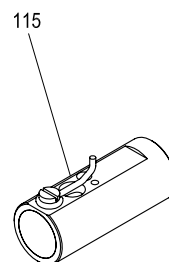
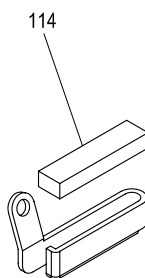
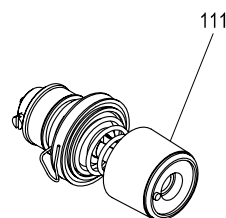
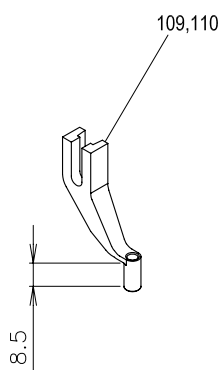
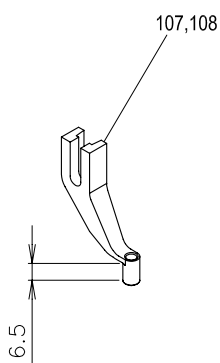
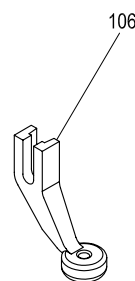
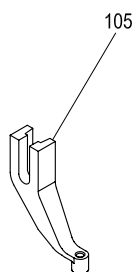
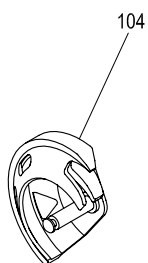
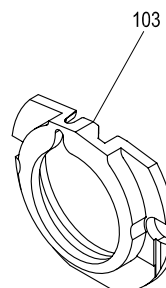
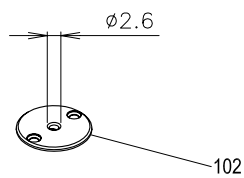
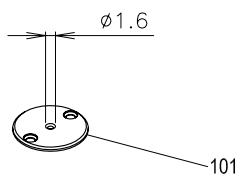

[T]オプションパーツ  
OPTION PARTS

Fig no.	変更 Mod.	部品コード Parts no.	品 名	Description	数量	
					Amt.	Req.
					4030	6030
T 101		MS03A0101	ハリイタ (ウスモノヨウ) $\phi$ 1.6	Needle plate (for light) $\phi$ 1.6	1	1
T 102		MS03A2101	ハリイタ (アツモノヨウ) $\phi$ 2.6	Needle plate (for heavy) $\phi$ 2.6	1	1
T 103		MS01A1616	ナカカマオサエ (アツモノヨウ)	Inner hook clamper (for heavy)	1	1
T 104		MS17A1120	ナカカマ (アツモノヨウ)	Inner hook (for heavy)	1	1
T 105		MV30A1256	ナカオサエ (ウスモノヨウ)	Presser foot (for light)	1	1
T 106		MV35A0106	サラオサエ	Presser foot	1	1
T 107		MS03A0256	ナカオサエ $\phi$ 3	Presser foot $\phi$ 3	1	1
T 108		MS03A1256	ナカオサエ $\phi$ 2	Presser foot $\phi$ 2	1	1
T 109		MA35A0256	ナカオサエ $\phi$ 3	Presser foot $\phi$ 3	1	1
T 110		MA35A1256	ナカオサエ $\phi$ 2	Presser foot $\phi$ 2	1	1
T 111		MS04E1210	ウワイトチヨウセツキ (クミ)	Thread tension regulator assy	1	1
T 112		MF10A1245	エンスイハネ (プリテンションヨウ)	Spring (for pretension)	1	1
T 113		MN10A3245	エンスイハネ (ウワイトチヨウセツキヨウ)	Spring (for thread tension regulator)	1	1
T 114		MS03A0181	イトアンナイ	Thread guide	1	1
T 115		MS10A0180	イトアンナイ	Thread guide	1	1

索引  
INDEX-1

部品コード Parts No.	ページ Page	Fig No.	部品コード Parts No.	ページ Page	Fig No.	部品コード Parts No.	ページ Page	Fig No.	部品コード Parts No.	ページ Page	Fig No.
K14M71725402	*** P29	*** Q 106	M90825053	*** P31	*** R 129	M91057020	*** P25	*** N 118	M91652020	*** P15	*** H 143
M800E2CON	*** P29	*** Q 108	M90853002	*** P11	*** F 129	M91058004	*** P19	*** K 101	M91688015	*** P13	*** G 109
M860A0FSW	*** P33	*** S 138	M90859004	*** P3	*** B 127	M91058020	*** P13	*** G 113	M91689015	*** P13	*** G 107
M90001043	*** P33	*** S 124	↑	*** P19	*** K 114	M91059004	*** P9	*** E 103	M91801035	*** P13	*** G 101
M90001060	*** P11	*** F 131	↑	*** P23	*** M 135	M91060021	*** P23	*** M 120	M91802006	*** P9	*** E 134
M90101017	*** P15	*** H 150	M90875045	*** P25	*** N 110	M91069004	*** P17	*** J 116	M91802045	*** P11	*** F 105
M90204060	*** P7	*** D 142	M90883080	*** P3	*** B 109	M91071004	*** P21	*** L 124	↑	*** P13	*** G 102
M90306041	*** P33	*** S 126	M90901002	*** P7	*** D 143	↑	*** P3	*** B 105	M91910080	*** P3	*** B 103
M90307053	*** P25	*** N 109	M90906003	*** P15	*** H 108	↑	*** P29	*** Q 101	M92002050	*** P31	*** R 124
M90317050	*** P25	*** N 108	↑	*** P3	*** B 126	M91073004	*** P29	*** Q 103	M92701080	*** P3	*** B 106
M90325065	*** P13	*** G 128	M90908003	*** P13	*** G 115	↑	*** P23	*** M 141	M93001050	*** P9	*** E 106
M90330065	*** P9	*** E 105	↑	*** P3	*** B 123	M91082004	*** P15	*** H 152	M93004021	*** P19	*** K 133
M90406064	*** P9	*** E 143	M90920002	*** P7	*** D 109	M91101017	*** P15	*** H 120	M93006050	*** P11	*** F 133
M90421050	*** P17	*** J 108	M90922002	*** P13	*** G 139	M91101046	*** P7	*** D 140	M93202045	*** P13	*** G 130
↑	*** P31	*** R 118	M90939002	*** P7	*** D 110	M91102045	*** P15	*** H 155	M93202047	*** P13	*** G 131
↑	*** P9	*** E 102	M90971004	*** P21	*** L 148	M91104045	*** P15	*** H 148	M94001017	*** P31	*** R 116
↑	*** P15	*** H 123	↑	*** P19	*** K 127	M91108001	*** P15	*** H 165	↑	*** P5	*** C 108
↑	*** P5	*** C 109	M90990002	*** P9	*** E 138	M91109045	*** P15	*** H 160	↑	*** P19	*** K 146
M90423060	*** P13	*** G 145	↑	*** P15	*** H 101	M91110002	*** P3	*** B 120	M94001021	*** P15	*** H 122
M90424053	*** P17	*** J 107	↑	*** P19	*** K 142	M91112002	*** P17	*** J 109	M94002017	*** P21	*** L 120
↑	*** P15	*** H 138	M90992002	*** P21	*** L 116	M91119002	*** P21	*** L 112	↑	*** P5	*** C 131
M90436037	*** P3	*** B 128	↑	*** P5	*** C 102	↑	*** P9	*** E 145	↑	*** P19	*** K 116
M90439037	*** P29	*** Q 107	M91004067	*** P7	*** D 119	M91127015	*** P17	*** J 101	M94002067	*** P15	*** H 133
↑	*** P33	*** S 125	M91005067	*** P7	*** D 121	M91129015	*** P15	*** H 111	M94003021	*** P19	*** K 156
M90442037	*** P3	*** B 119	M91007045	*** P15	*** H 137	M91131002	*** P13	*** G 146	M94003099	*** P19	*** K 128
M90445037	*** P5	*** C 134	↑	*** P31	*** R 115	M91182080	*** P3	*** B 122	↑	*** P21	*** L 153
M90447037	*** P3	*** B 115	↑	*** P19	*** K 155	M91203002	*** P11	*** F 101	M94004099	*** P27	*** P 113
M90500085	*** P11	*** F 116	↑	*** P17	*** J 106	M91214015	*** P15	*** H 117	M94005017	*** P19	*** K 148
M90504053	*** P15	*** H 163	M91010004	*** P19	*** K 112	M91219015	*** P13	*** G 147	M94007017	*** P23	*** M 125
M90511050	*** P5	*** C 105	M91010089	*** P33	*** S 134	M91223001	*** P11	*** F 104	↑	*** P31	*** R 122
↑	*** P31	*** R 138	M91011004	*** P7	*** D 135	M91224001	*** P15	*** H 116	↑	*** P21	*** L 119
↑	*** P19	*** K 151	M91013004	*** P7	*** D 104	M91276004	*** P7	*** D 102	M94008017	*** P19	*** K 145
↑	*** P23	*** M 109	M91035089	*** P29	*** Q 127	↑	*** P29	*** Q 126	M94008070	*** P23	*** M 124
↑	*** P15	*** H 162	M91050020	*** P15	*** H 128	M91300004	*** P3	*** B 111	M94012017	*** P19	*** K 132
↑	*** P29	*** Q 122	↑	*** P23	*** M 130	M9130410	*** P21	*** L 135	M94015021	*** P31	*** R 119
M90512050	*** P21	*** L 110	M91053020	*** P7	*** D 133	M91382045	*** P15	*** H 121	M94017021	*** P21	*** L 133
M90512065	*** P23	*** M 104	↑	*** P9	*** E 120	↑	*** P17	*** J 112	M94018017	*** P19	*** K 154
M90513065	*** P15	*** H 113	M91054004	*** P31	*** R 106	↑	*** P31	*** R 139	M94039021	*** P19	*** K 159
M90601064	*** P7	*** D 123	↑	*** P27	*** P 104	M91383045	*** P15	*** H 131	M95001017	*** P19	*** K 150
M90604065	*** P21	*** L 136	↑	*** P25	*** N 101	M91503001	*** P11	*** F 112	↑	*** P23	*** M 118
M90605010	*** P15	*** H 103	↑	*** P3	*** B 102	M91506001	*** P13	*** G 136	M95001021	*** P11	*** F 126
M90611060	*** P23	*** M 132	↑	*** P7	*** D 131	M91511056	*** P5	*** C 129	M95002017	*** P5	*** C 113
M90624053	*** P31	*** R 135	↑	*** P21	*** L 152	M91515022	*** P13	*** G 144	↑	*** P23	*** M 108
M90631050	*** P31	*** R 136	↑	*** P19	*** K 121	M91520002	*** P9	*** E 112	M95002020	*** P23	*** M 103
↑	*** P13	*** G 123	M91055020	*** P7	*** D 112	M91551015	*** P13	*** G 125	M95003001	*** P9	*** E 123
M90632050	*** P13	*** G 133	M91056004	*** P13	*** G 104	M91572045	*** P13	*** G 122	↑	*** P11	*** F 110
M90802002	*** P17	*** J 102	↑	*** P21	*** L 150	M91576045	*** P15	*** H 142	↑	*** P9	*** E 126
M90802003	*** P11	*** F 132	↑	*** P19	*** K 106	↑	*** P23	*** M 107	M95003017	*** P13	*** G 150
↑	*** P25	*** N 113	↑	*** P23	*** M 136	M91602001	*** P9	*** E 118	↑	*** P23	*** M 142
M90803053	*** P31	*** R 108	↑	*** P15	*** H 139	M91602046	*** P7	*** D 124	M95003021	*** P15	*** H 144
M90806002	*** P3	*** B 117	↑	*** P25	*** N 102	M91603003	*** P13	*** G 121	M95004017	*** P21	*** L 123
M90810004	*** P19	*** K 104	↑	*** P33	*** S 130	M91605045	*** P7	*** D 150	↑	*** P23	*** M 129
M90815002	*** P9	*** E 132	↑	*** P5	*** C 127	M91606001	*** P9	*** E 135	M95004020	*** P13	*** G 157
M90816004	*** P5	*** C 136	↑	*** P29	*** Q 109	↑	*** P13	*** G 129	↑	*** P7	*** D 152
M90824050	*** P31	*** R 128	M91057020	*** P7	*** D 115	M91650020	*** P11	*** F 114	M95004021	*** P11	*** F 107

索引  
INDEX-2

部品コード Parts No.	ページ Page	Fig No.	部品コード Parts No.	ページ Page	Fig No.	部品コード Parts No.	ページ Page	Fig No.	部品コード Parts No.	ページ Page	Fig No.
M95004021	*** P15	*** H 149	MA20A0603	*** P17	*** J 111	MA35A8339	*** P3	*** B 129	MB35A0600	*** P7	*** D 101
M95004023	*** P15	*** H 125	MA20A0719	*** P31	*** R 117	MA35A9339	*** P3	*** B 130	MB35A0639	*** P21	*** L 155
M95005017	*** P29	*** Q 121	MA20A0734	*** P33	*** S 133	MA35A9603	*** P19	*** K 152	MB35A0708	*** P15	*** H 153
↑	*** P5	*** C 106	MA20A0740	*** P11	*** F 119	MA35B0601	*** P19	*** K 115	MB35A0849	*** P3	*** B 104
↑	*** P17	*** J 110	MA20A1780	*** P27	*** P 112	MA35B0920	*** P19	*** K 149	MB35A0957	*** P19	*** K 147
M95006017	*** P13	*** G 153	MA20A1910	*** P15	*** H 114	MA35B1920	*** P19	*** K 134	MB35A1523	*** P21	*** L 114
M95006020	*** P9	*** E 139	MA20A2434	*** P23	*** M 115	MA35B7601	*** P31	*** R 133	MB35A1571	*** P21	*** L 127
M95008021	*** P21	*** L 139	MA20A4454	*** P15	*** H 127	MA35B8601	*** P31	*** R 137	MB35A1849	*** P3	*** B 132
M95011021	*** P21	*** L 111	MA20A6571	*** P29	*** Q 123	MA35E0450	*** P11	*** F 120	MB35A2339	*** P31	*** R 101
M95015017	*** P19	*** K 157	MA20A6688	*** P27	*** P 117	MA36A0105	*** P23	*** M 139	MB35A3601	*** P21	*** L 151
M95015021	*** P15	*** H 164	MA20A8571	*** P29	*** Q 120	MA36A0272	*** P23	*** M 143	MB35A6601	*** P19	*** K 158
M95016017	*** P21	*** L 109	MA20A9571	*** P23	*** M 114	MA36A0273	*** P23	*** M 128	MB35A7601	*** P29	*** Q 110
M95018021	*** P21	*** L 132	MA20B1601	*** P23	*** M 113	MA36A0797	*** P33	*** S 137	MB35A8601	*** P19	*** K 139
↑	*** P23	*** M 126	MA21P0454	*** P21	*** L 138	MA36A1920	*** P19	*** K 153	MB35E0776	*** P3	*** B 112
M95021045	*** P31	*** R 125	MA22A0957	*** P23	*** M 123	MA36E0105	*** P23	*** M 901	MB35E0975	*** P15	*** H 134
M95035021	*** P31	*** R 132	MA25A1476	*** P23	*** M 138	MA45A2196	*** P23	*** M 140	MB45A0150	*** P31	*** R 123
M95044021	*** P21	*** L 141	MA30A0364	*** P21	*** L 157	MA45A7426	*** P23	*** M 137	MB45A0767	*** P21	*** L 108
M95049021	*** P15	*** H 136	MA30A0571	*** P33	*** S 135	MA60A0105	*** P23	*** M 139	MB45A1957	*** P23	*** M 127
M95049095	*** P21	*** L 128	MA30A0758	*** P21	*** L 125	MA60A0226	*** P19	*** K 102	MB45A6601	*** P31	*** R 121
M95050021	*** P21	*** L 141	MA35A0166	*** P31	*** R 126	MA60A0272	*** P23	*** M 143	MB45E0599	*** P29	*** Q 125
M95050095	*** P21	*** L 101	MA35A0256	*** P35	*** T 109	MA60A0273	*** P23	*** M 128	MB50S0370	*** P5	*** C 130
M95051095	*** P21	*** L 128	MA35A0308	*** P23	*** M 117	MA60A0390	*** P21	*** L 146	MB50S0809	*** P5	*** C 137
M95052095	*** P21	*** L 101	MA35A0361	*** P5	*** C 112	MA60A0458	*** P19	*** K 105	MB60A0201	*** P33	*** S 129
M96001001	*** P21	*** L 107	MA35A0454	*** P23	*** M 116	MA60A0477	*** P19	*** K 143	MB60A0366	*** P29	*** Q 104
M96002001	*** P21	*** L 104	MA35A0458	*** P19	*** K 113	MA60A0601	*** P5	*** C 115	MB60A0420	*** P33	*** S 127
M96002017	*** P23	*** M 112	MA35A0523	*** P21	*** L 129	MA60A0797	*** P33	*** S 137	MB60A0601	*** P3	*** B 121
M96004052	*** P15	*** H 110	MA35A0564	*** P21	*** L 142	MA60A0957	*** P19	*** K 131	MB60A0694	*** P9	*** E 111
M96006017	*** P21	*** L 102	MA35A0572	*** P15	*** H 154	MA60A1226	*** P19	*** K 103	MB60A0740	*** P11	*** F 102
M96016021	*** P31	*** R 134	MA35A0602	*** P19	*** K 140	MA60A1339	*** P3	*** B 131	MB60A0915	*** P25	*** N 105
M96062021	*** P15	*** H 158	MA35A0621	*** P23	*** M 105	MA60A1390	*** P21	*** L 158	MB60A1601	*** P7	*** D 118
M97011060	*** P23	*** M 106	MA35A0708	*** P15	*** H 130	MA60A1476	*** P19	*** K 130	MB60A1620	*** P3	*** B 108
M97318099	*** P29	*** Q 118	MA35A0833	*** P9	*** E 121	MA60A1601	*** P5	*** C 122	↑	*** P33	*** S 132
M97319099	*** P29	*** Q 116	MA35A1256	*** P35	*** T 110	MA60A3226	*** P19	*** K 118	MB60A1780	*** P27	*** P 122
M97320099	*** P29	*** Q 117	MA35A1361	*** P19	*** K 129	MA60A3339	*** P3	*** B 129	MB60A1990	*** P33	*** S 107
M97321099	*** P29	*** Q 114	MA35A1419	*** P31	*** R 113	MA60A3603	*** P21	*** L 113	MB60A2352	*** P29	*** Q 105
M98001021	*** P31	*** R 102	MA35A1477	*** P19	*** K 135	MA60A4226	*** P19	*** K 107	MB60A2620	*** P33	*** S 131
M98003015	*** P11	*** F 108	MA35A1572	*** P15	*** H 132	MA60A4426	*** P5	*** C 118	MB60A3957	*** P31	*** R 114
M98004017	*** P31	*** R 140	MA35A1602	*** P19	*** K 141	MA60A5226	*** P19	*** K 108	MB60A5601	*** P29	*** Q 111
M98011021	*** P31	*** R 130	MA35A1758	*** P21	*** L 126	MA60A5426	*** P5	*** C 117	MB60A5780	*** P29	*** Q 112
M98015021	*** P31	*** R 107	MA35A1781	*** P21	*** L 145	MA60A5920	*** P19	*** K 153	MB60A6780	*** P29	*** Q 113
M99006063	*** P7	*** D 114	MA35A1833	*** P11	*** F 117	MA60A6226	*** P19	*** K 109	MB60E0190	*** P7	*** D 901
↑	*** P13	*** G 114	MA35A1950	*** P15	*** H 126	MA60A6920	*** P19	*** K 149	MB60E0234	*** P9	*** E 904
MA04A1530	*** P7	*** D 108	MA35A2390	*** P21	*** L 122	MA60A7226	*** P19	*** K 111	MB60E0682	*** P9	*** E 113
MA04A2530	*** P7	*** D 111	MA35A2458	*** P19	*** K 105	MA60E0105	*** P23	*** M 902	MB60E0950	*** P7	*** D 113
MA10A0120	*** P11	*** F 124	MA35A2477	*** P23	*** M 121	MA65A0339	*** P31	*** R 103	MB60E0982	*** P25	*** N 116
MA10A0123	*** P11	*** F 122	MA35A2530	*** P15	*** H 129	MB02A0608	*** P33	*** S 118	MB60E1682	*** P9	*** E 901
↑	*** P33	*** S 102	MA35A2572	*** P9	*** E 141	MB02A1608	*** P33	*** S 117	MB60E1956	*** P11	*** F 901
MA10B2476	*** P15	*** H 106	MA35A2950	*** P23	*** M 101	MB35A0139	*** P31	*** R 111	MB60E3339	*** P25	*** N 902
MA16A0495	*** P29	*** Q 124	MA35A3339	*** P31	*** R 103	MB35A0230	*** P9	*** E 122	MB60E6339	*** P3	*** B 125
MA16E0210	*** P7	*** D 904	MA35A3458	*** P19	*** K 110	MB35A0339	*** P29	*** Q 102	MB62A0352	*** P7	*** D 103
MA20A0194	*** P7	*** D 116	MA35A3477	*** P19	*** K 144	MB35A0390	*** P21	*** L 105	MB62A0453	*** P11	*** F 113
MA20A0361	*** P5	*** C 116	MA35A3572	*** P23	*** M 110	MB35A0429	*** P31	*** R 110	MB62A0454	*** P15	*** H 115
MA20A0392	*** P15	*** H 118	MA35A4601	*** P19	*** K 119	MB35A0476	*** P21	*** L 147	MB62A0456	*** P21	*** L 121
MA20A0476	*** P7	*** D 105	MA35A4950	*** P23	*** M 119	MB35A0523	*** P21	*** L 143	MB62A0626	*** P13	*** G 140
MA20A0584	*** P7	*** D 132	MA35A7339	*** P3	*** B 131	MB35A0571	*** P21	*** L 103	MB62A0757	*** P29	*** Q 125

索引  
INDEX-3

部品コード Parts No.	ページ Page	Fig No.	部品コード Parts No.	ページ Page	Fig No.	部品コード Parts No.	ページ Page	Fig No.	部品コード Parts No.	ページ Page	Fig No.
MB62A0767	*** P21	*** L 137	ME40A0571	*** P13	*** G 154	ME60A0407	*** P19	*** K 138	MG30A0833	*** P13	*** G 120
MB62A4601	*** P5	*** C 110	ME40A0601	*** P5	*** C 133	ME60A0429	*** P5	*** C 114	MG30B0226	*** P13	*** G 108
MB65A0228	*** P19	*** K 117	ME40A0604	*** P5	*** C 125	ME60A0458	*** P19	*** K 110	MG30B0740	*** P13	*** G 127
MB65A0390	*** P21	*** L 156	ME40A0715	*** P5	*** C 126	ME60A0470	*** P5	*** C 101	MG43A0181	*** P7	*** D 141
MB65A0429	*** P31	*** R 110	ME40A0738	*** P13	*** G 148	ME60A0477	*** P19	*** K 143	MG50A0740	*** P9	*** E 114
MB65A0476	*** P23	*** M 138	ME40A0758	*** P5	*** C 104	ME60A0601	*** P31	*** R 141	MG51A0201	*** P33	*** S 128
MB65A0601	*** P29	*** Q 110	ME40A0770	*** P5	*** C 139	ME60A0799	*** P5	*** C 107	MG75A0265	*** P13	*** G 135
MB65A0849	*** P3	*** B 104	ME40A0776	*** P31	*** R 105	ME60A1339	*** P31	*** R 104	MG75A1476	*** P7	*** D 130
MB65A1849	*** P3	*** B 132	ME40A0777	*** P3	*** B 110	ME60A1361	*** P5	*** C 123	MM10A1479	*** P33	*** S 121
ME03A0270	*** P25	*** N 106	ME40A0778	*** P21	*** L 118	ME60A1429	*** P5	*** C 119	MM11A0245	*** P7	*** D 126
ME10A0148	*** P11	*** F 118	ME40A0799	*** P5	*** C 107	ME60A1477	*** P19	*** K 144	MM11A0352	*** P11	*** F 111
ME10A0261	*** P13	*** G 103	ME40A0920	*** P21	*** L 130	ME60A2429	*** P5	*** C 120	MM11A0556	*** P7	*** D 147
ME10A0572	*** P13	*** G 105	ME40A0963	*** P29	*** Q 119	ME60A3429	*** P5	*** C 124	MM11A0702	*** P7	*** D 125
ME10A0742	*** P3	*** B 101	ME40A1339	*** P29	*** Q 102	ME60E0150	*** P31	*** R 131	MN10A0135	*** P27	*** P 118
ME10A0763	*** P13	*** G 111	ME40A1407	*** P21	*** L 115	ME60E0691	*** P33	*** S 902	MN10A1456	*** P9	*** E 104
ME10A0956	*** P13	*** G 124	ME40A1419	*** P31	*** R 109	MF00A0181	*** P7	*** D 136	MN10A3245	*** P35	*** T 113
ME10A1252	*** P13	*** G 142	ME40A1429	*** P5	*** C 111	MF00A0553	*** P7	*** D 137	MN52A1245	*** P7	*** D 148
ME10A1780	*** P27	*** P 103	ME40A1476	*** P21	*** L 144	MF00A0608	*** P33	*** S 119	↑	*** P33	*** S 105
ME10A1956	*** P13	*** G 118	ME40A1508	*** P29	*** Q 115	MF00A2780	*** P27	*** P 108	MN55A0975	*** P15	*** H 119
ME10A6910	*** P13	*** G 110	ME40A1601	*** P5	*** C 138	MF00E0550	*** P7	*** D 903	MN60A0620	*** P27	*** P 133
ME10A7910	*** P13	*** G 112	ME40A1758	*** P21	*** L 140	MF01A0181	*** P9	*** E 133	↑	*** P3	*** B 107
ME10E0452	*** P11	*** F 902	ME40A2339	*** P31	*** R 104	MF01A0259	*** P9	*** E 107	MN60A0750	*** P17	*** J 113
ME10E1830	*** P3	*** B 116	ME40A2419	*** P31	*** R 112	MF01A0476	*** P9	*** E 110	MN70A1780	*** P13	*** G 116
ME10E3601	*** P25	*** N 104	ME40A2477	*** P21	*** L 161	MF01A0565	*** P33	*** S 104	MN72A0975	*** P15	*** H 124
ME20A0406	*** P9	*** E 101	ME40A2601	*** P19	*** K 122	MF01A1476	*** P9	*** E 108	MN72A1694	*** P9	*** E 109
ME20A0484	*** P19	*** K 126	ME40A3477	*** P21	*** L 134	MF10A0149	*** P33	*** S 116	MS01A0121	*** P11	*** F 128
ME20E0990	*** P33	*** S 901	↑	*** P21	*** L 159	MF10A0181	*** P7	*** D 151	MS01A0160	*** P3	*** B 113
ME25A0416	*** P9	*** E 146	ME40A3601	*** P19	*** K 123	MF10A0187	*** P7	*** D 146	MS01A0192	*** P15	*** H 112
ME25A0434	*** P13	*** G 155	ME40A4477	*** P21	*** L 160	MF10A0267	*** P13	*** G 137	MS01A0329	*** P11	*** F 130
ME25A0454	*** P9	*** E 142	ME40A4601	*** P19	*** K 125	MF10A0325	*** P9	*** E 137	MS01A0348	*** P15	*** H 145
ME25A0477	*** P13	*** G 149	ME40A5601	*** P21	*** L 154	MF10A0553	*** P7	*** D 145	MS01A0350	*** P9	*** E 125
ME25A0551	*** P7	*** D 106	ME40A6601	*** P31	*** R 141	MF10A0555	*** P7	*** D 127	MS01A0361	*** P3	*** B 124
ME25A0571	*** P13	*** G 152	ME40A7601	*** P21	*** L 131	MF10A0709	*** P7	*** D 144	MS01A0383	*** P9	*** E 905
ME25A0601	*** P13	*** G 151	ME40E0150	*** P31	*** R 131	MF10A1245	*** P35	*** T 112	MS01A0508	*** P11	*** F 106
ME25A0682	*** P9	*** E 144	ME40E0270	*** P25	*** N 901	MF10A1555	*** P7	*** D 138	MS01A0572	*** P11	*** F 134
ME25A0950	*** P7	*** D 107	ME40E0519	*** P15	*** H 141	MF10A2740	*** P27	*** P 102	MS01A0611	*** P11	*** F 125
ME25A1454	*** P13	*** G 156	ME40E0688	*** P27	*** P 132	MF20A0130	*** P31	*** R 120	MS01A0660	*** P9	*** E 128
ME25A1833	*** P9	*** E 140	ME40E0691	*** P33	*** S 902	MF21D0181	*** P9	*** E 130	MS01A0663	*** P9	*** E 127
ME25E0331	*** P9	*** E 906	ME40E0746	*** P17	*** J 115	MF36A0245	*** P7	*** D 139	MS01A0761	*** P11	*** F 115
ME40A0161	*** P19	*** K 137	ME40E1519	*** P17	*** J 114	MF36A0750	*** P17	*** J 103	MS01A0833	*** P11	*** F 103
ME40A0196	*** P19	*** K 120	ME40E1688	*** P27	*** P 130	MF36A1180	*** P7	*** D 134	MS01A0891	*** P11	*** F 109
ME40A0200	*** P19	*** K 901	ME40E2519	*** P25	*** N 107	MF40E0193	*** P33	*** S 106	MS01A1392	*** P15	*** H 161
ME40A0339	*** P19	*** K 124	ME40E2688	*** P27	*** P 131	MF60A0700	*** P13	*** G 126	MS01A1476	*** P15	*** H 105
ME40A0368	*** P31	*** R 127	ME40E3688	*** P27	*** P 123	MF60A0742	*** P27	*** P 101	MS01A1572	*** P15	*** H 146
ME40A0407	*** P19	*** K 138	ME40E4688	*** P27	*** P 119	MF60A2740	*** P9	*** E 124	MS01A1616	*** P35	*** T 103
ME40A0419	*** P5	*** C 132	ME40E5688	*** P27	*** P 128	MF60A5740	*** P27	*** P 124	MS01A1740	*** P27	*** P 106
ME40A0426	*** P23	*** M 137	ME40E6688	*** P27	*** P 116	MF70A0350	*** P13	*** G 143	MS01A1976	*** P33	*** S 110
ME40A0429	*** P5	*** C 103	ME40E7688	*** P27	*** P 111	MF70A0352	*** P9	*** E 117	MS01A2392	*** P15	*** H 159
ME40A0454	*** P23	*** M 131	ME40E8688	*** P27	*** P 121	MF70A1180	*** P7	*** D 153	MS01A3352	*** P15	*** H 901
ME40A0470	*** P5	*** C 101	ME40E9688	*** P27	*** P 110	MF80A0780	*** P27	*** P 107	MS01A8796	*** P27	*** P 129
ME40A0476	*** P21	*** L 117	ME40F0688	*** P27	*** P 120	MF90A0361	*** P17	*** J 104	MS01A9796	*** P27	*** P 126
ME40A0477	*** P19	*** K 136	ME40F1688	*** P27	*** P 115	MF90A0976	*** P33	*** S 111	MS01E0351	*** P15	*** H 147
ME40A0481	*** P5	*** C 135	ME60A0200	*** P19	*** K 901	MG30A0664	*** P9	*** E 129	MS01E0430	*** P15	*** H 135
ME40A0484	*** P21	*** L 149	ME60A0339	*** P3	*** B 130	MG30A0740	*** P13	*** G 117	MS01E0580	*** P9	*** E 902
ME40A0508	*** P25	*** N 103	ME60A0361	*** P5	*** C 121	MG30A0760	*** P13	*** G 901	MS01E0975	*** P15	*** H 151



索引  
INDEX-4

部品コード Parts No.	ページ Page	Fig No.	部品コード Parts No.	ページ Page	Fig No.	部品コード Parts No.	ページ Page	Fig No.	部品コード Parts No.	ページ Page	Fig No.
MS02A0128	*** P33	*** S 101	MS14A0740	*** P27	*** P 125						
↑	*** P9	*** E 131	MS14A0838	*** P15	*** H 107						
MS02A0463	*** P13	*** G 902	MS14A1620	*** P5	*** C 128						
MS02A0479	*** P33	*** S 120	MS14A3601	*** P15	*** H 140						
MS02A0976	*** P33	*** S 114	MS14A3603	*** P15	*** H 156						
MS02A1352	*** P23	*** M 102	MS14A3780	*** P27	*** P 127						
MS02A1477	*** P25	*** N 115	MS14E0180	*** P7	*** D 902						
MS02A1976	*** P33	*** S 113	MS17A0125	*** P11	*** F 121						
MS02A2456	*** P21	*** L 106	MS17A1120	*** P35	*** T 104						
MS02A2976	*** P33	*** S 112	MS18A0470	*** P15	*** H 102						
MS02A4729	*** P25	*** N 111	MS35A2708	*** P23	*** M 111						
MS02B0257	*** P23	*** M 134	MT60A0802	*** P7	*** D 149						
MS02E0460	*** P13	*** G 119	MV30A0256	*** P13	*** G 141						
MS02E0983	*** P25	*** N 112	MV30A1256	*** P35	*** T 105						
MS03A0101	*** P35	*** T 101	MV35A0106	*** P35	*** T 106						
MS03A0181	*** P35	*** T 114	MV88A0740	*** P9	*** E 116						
MS03A0256	*** P35	*** T 107									
MS03A0262	*** P13	*** G 138									
MS03A0417	*** P33	*** S 103									
↑	*** P7	*** D 117									
MS03A0703	*** P13	*** G 132									
MS03A1101	*** P15	*** H 104									
MS03A1256	*** P35	*** T 108									
MS03A1530	*** P25	*** N 117									
MS03A1572	*** P13	*** G 134									
MS03A2101	*** P35	*** T 102									
MS03A2780	*** P27	*** P 105									
MS03A3980	*** P25	*** N 119									
MS03A6154	*** P13	*** G 106									
MS03B0838	*** P15	*** H 109									
MS03E0662	*** P9	*** E 136									
MS03E0981	*** P25	*** N 114									
MS04E1210	*** P35	*** T 111									
MS05A0976	*** P33	*** S 109									
MS05A1976	*** P33	*** S 108									
MS06A0567	*** P33	*** S 136									
MS07A0228	*** P17	*** J 105									
MS08A0454	*** P15	*** H 157									
MS08A0616	*** P11	*** F 123									
MS08A0740	*** P27	*** P 109									
MS09A0950	*** P11	*** F 127									
MS10A0180	*** P35	*** T 115									
MS10A0232	*** P9	*** E 903									
MS10A0780	*** P27	*** P 114									
MS10A0976	*** P33	*** S 115									
MS10A1740	*** P9	*** E 115									
MS10A1976	*** P33	*** S 122									
MS10A2976	*** P33	*** S 123									
MS13A0572	*** P23	*** M 133									
MS13A2477	*** P23	*** M 122									
MS14A0180	*** P7	*** D 129									
MS14A0350	*** P7	*** D 120									
MS14A0553	*** P7	*** D 128									
MS14A0572	*** P7	*** D 122									
MS14A0682	*** P9	*** E 119									

MEMO

A series of horizontal dotted lines for writing.

 **三菱電機株式会社**

 **MITSUBISHI ELECTRIC CORPORATION**