

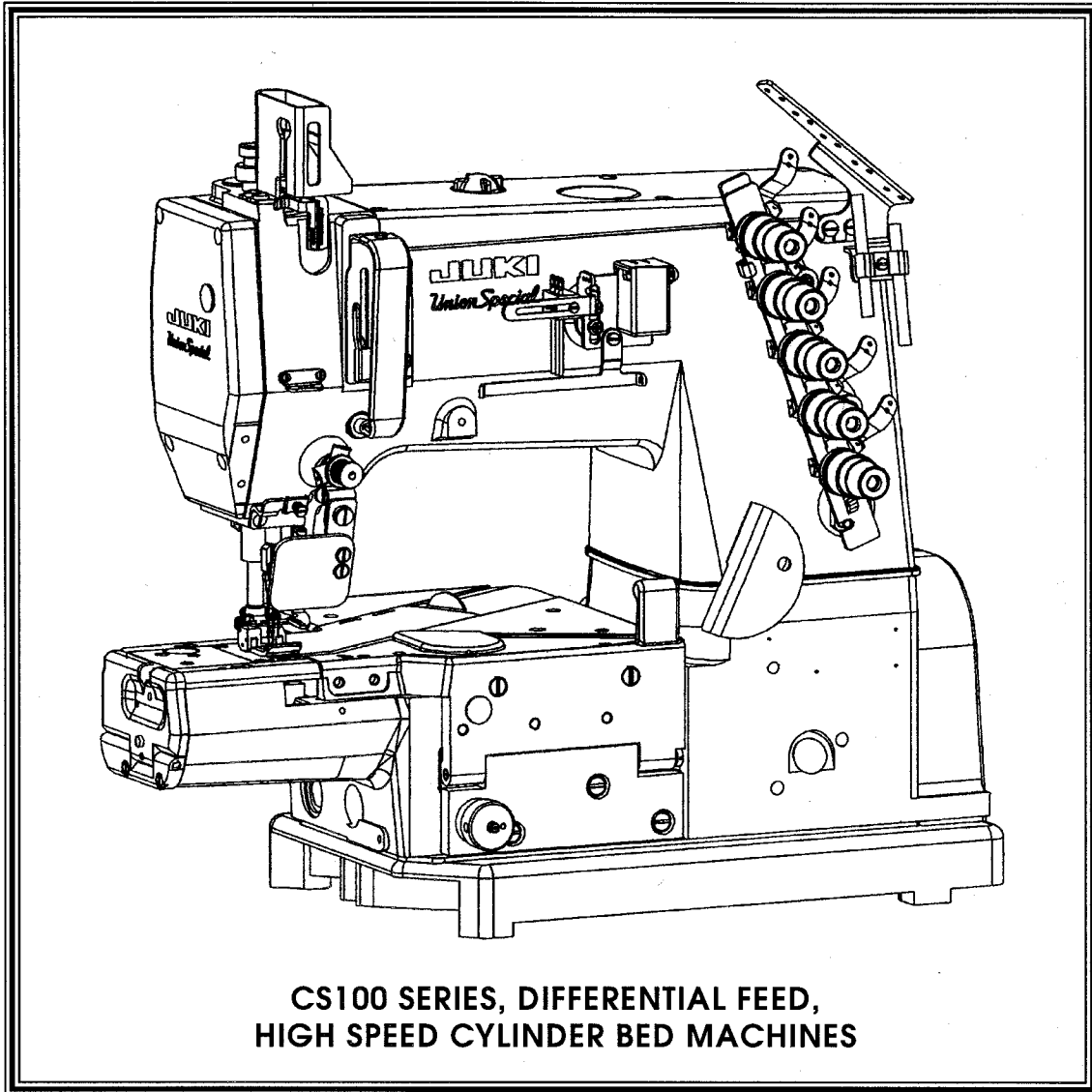

JUKI

Union Special

ILLUSTRATED PARTS MANUAL



CS100 SERIES, DIFFERENTIAL FEED,
HIGH SPEED CYLINDER BED MACHINES

MANUAL NO. PT9801
FOR STYLES

CS122E11	CS122H01	CS122H21	CS122K01
CS132E11	CS132H01	CS132H21	CS132K01
CS125E61	CS125H11	CS125H31	CS122K02
CS125E62	CS135H11	CS135H31	CS132K02
CS135E61	CS125H12	CS125H32	
CS135E62	CS135H12	CS135H32	

USE IN CONJUNCTION WITH MACHINE SERIAL NUMBER PREFIX (BG) AND LATER

Manual No. PT9801 Illustrated Parts List for CS100 Series Machines

Second Edition Copyright 2000

By

Union Special Corporation Rights Reserved In All Countries

Printed in U.S.A. April 2000

PREFACE

This parts manual has been prepared to assist you in locating individual parts or assemblies on CS100 Series machines.

IDENTIFICATION OF MACHINES

Each UNION SPECIAL machine is identified by a style number, which is stamped into the style plate affixed to the middle of the machine under the tension assembly. The serial number is stamped into the serial number plate affixed to the right rear base of the machine.



CONTENTS

PREFACE	2
IDENTIFICATION OF MACHINES	2
STYLES OF MACHINES	4
STYLES OF MACHINES (CONT.)	5
ILLUSTRATIONS	5
IDENTIFYING PARTS	5
NEEDLES	5
SAFETY RULES	6
BUSHINGS	9
NEEDLE BAR	11
UPPER MAIN SHAFT	13
SPREADER	15
THREAD GUIDE	17
PRESSER FOOT LIFT	21
COVERS, UPPER ARM	23
LOWER MAIN SHAFT	25
LUBRICATION, OIL TUBING & OIL PUMP	27
LOOPER DRIVE	29
LOOPER THREAD TAKE -UP & NEEDLE GUARD	31
FEED DRIVE MECHANISM	33
FEED DRIVE MECHANISM	35
COVERS	
FOR CS122E11, CS132E11, CS125E61, CS125E62, CS135E61, CS135E62	37
COVERS LOWER BED- FRONT	39
COVERS LOWER BED- MIDDLE	41
COVERS LOWER BED - REAR	43
SEWING PARTS	
FOR CS122E11, CS125E61, CS125E62, CS132E11, CS135E61, CS135E62	45
SEWING PARTS	
FOR CS122H01, CS132H01	47
SEWING PARTS	
FOR CS125H11, CS125H12, CS135H11, CS135H12	49
SEWING CHART	
FOR CS125H11, CS135H11	50
SEWING CHART	
FOR CS125H12, CS135H12	51
SEWING PARTS	
FOR CS122H21, CS132H21	53
SEWING PARTS	
FOR CS122K01, CS122K02, CS132K01, CS132K02	55
ACCESSORIES	57
TAPE GUIDE, HOLD DOWN DEVICE	
FOR CS122E11, CS125E61, CS125E62, CS132E11, CS135E61, CS135E62	59
UNDER TRIMMER ASSEMBLY	
FOR CS122E11, CS125E61, CS125E62, CS132E11, CS135E61, CS135E62	61
PULLER LIFTER ASSEMBLY	
FOR CS125E61, CS125E62, CS125H11, CS125H12, CS135E61, CS135E62, CS135H11, CS135H12	63
PULLER DRIVE ASSEMBLY	
FOR CS125E61, CS125E62, CS125H11, CS125H12, CS135E61, CS135E62, CS135H11, CS135H12	65
LOWER ROLLER ASSEMBLY	
FOR CS125E61, CS125E62, CS125H11, CS125H12, CS135E61, CS135E62, CS135H11, CS135H12	67
UPPER ROLLER ASSEMBLY	
FOR CS125E61, CS125E62, CS125H11, CS125H12, CS135E61, CS135E62, CS135H11, CS135H12	69
FABRIC TRIMMER ASSEMBLY	
FOR CS122H21, CS132H21	71
NEEDLE DIPPER (EXTRA SEND CHARGE)	73
NUMERICAL INDEX OF PARTS	74
NUMERICAL INDEX OF PARTS	75
NUMERICAL INDEX OF PARTS	76
NUMERICAL INDEX OF PARTS	77
NOTES	78
NOTES	79



STYLES OF MACHINES

Precision two or three needle cylinder bed machines, with top and bottom coverstitch or bottom coverstitch only. Rotary mainshafts for smoother, quieter and faster operations. Equipped with quick change for main and differential feed. Independently driven rear needle guard, no adjustment necessary when changing stitch length. Adjustable looper avoid eccentric to adapt the looper avoid motion and the elliptic path of looper to the required needle size and type of sewing threads. Recommended needle 121GJS, needle range sizes 055/022 - 090/036.

- CS122E11 ELASTIC. Two or three needle, bottom coverstitch, right hand fabric undertrimmer. - Typical Application - For attaching preclosed elastic while trimming the edge of the fabric. Seam Specification for two needle 406 LSc-1, for three needle 407 LSc-1. Standard gauge for two needle 40, (5/32", 4.0mm), 48, (3/16", 4.8mm), for three needle 56, (7/32", 5.6mm), 64, (1/4", 6.4mm). Maximum recommended speed, depending on application is up to 5500 R.P.M..
- CS132E11 ELASTIC. Same as Style CS122E11 except top coverstitch, Seam Specification for two needle 602 LSc-1, for three needle 605 LSc-1.
- CS125E61 ELASTIC. Same as CS122E11 except equipped with rear roller.
- CS125E62 ELASTIC. Same as CS122E11 except equipped with rear roller.
- CS135E61 ELASTIC. Same as CS132E11 except equipped with rear roller.
- CS135E62 ELASTIC. Same as CS132E11 except equipped with rear roller.
- CS122H01 HEMMING. Two or three needle, bottom coverstitch. - Typical Application - For circular hemming operations on light, medium and heavy weight knit fabrics. Seam Specifications for two needle 406 EFa-1 (inv.), for three needle 407 EFa-1 (inv.). Standard gauges for two needle 40, (5/32", 4.0mm), 48, (3/16", 4.8mm), for three needle 56, (7/32", 5.6mm), 64, (1/4", 6.4mm). Recommended speed, depending on application is up to 6500 R.P.M..
- CS132H01 HEMMING. Same as Style CS122H01 except, top and bottom coverstitch. Seam Specification for two needle 602 EFa-1 (inv.), for three needle 605 EFa-1 (inv.).
- CS125H11 HEMMING. Two or three needle, rear puller. - Typical Application - For hemming applications. Seam Specifications for two needle 406 EFa-1 (inv.), for three needle 407 EFa-1 (inv.). Standard gauges for two needle 40, (5/32", 4.0mm), 48, (3/16", 4.8mm), for three needle 56, (7/32", 5.6mm), 64, (1/4", 6.4mm). Maximum recommended speed, depending on application is up to 6000 R.P.M..
- CS135H11 HEMMING. Same as Style CS125H11 except top and bottom coverstitch. Seam Specification for two needle 602 EFa-1 (inv.), for three needle 605 EFa-1 (inv.).
- CS125H12 HEMMING. Same as CS125H11 except equipped with rubber roller on rear puller.
- CS135H12 HEMMING. Same as CS135H11 except equipped with rubber roller on rear puller.
- CS122H21 HEMMING. Two or three needle, left hand fabric undertrimmer, bottom coverstitch. - Typical Application - For general hemming of circular openings while trimming the edge of the hem. Seam Specifications for two needle 406 EFa-1 (inv.), for three needle 407 EFa-1 (inv.). Standard gauges for two needle 40, (5/32", 4.0mm), 48, (3/16", 4.8mm), for three needle 56, (7/32", 5.6mm), 64, (1/4", 6.4mm). Maximum recommended speed, depending on application is up to 5500 R.P.M..
- CS132H21 HEMMING. Same as Style CS122H21 except top and bottom coverstitch. Seam Specification for two needle 602 EFa-1 (inv.), for three needle 605 EFa-1 (inv.).
- CS122K01 COVERSEAM. Two needle, bottom coverstitch. - Typical Application - for the second operation to bottom coverstitch overedge seams of circular openings such as shoulder, neck, and waist of light weight knit garments. Seam Specification 406 SSh-2. Standard gauges 48, (3/16", 4.8mm), 56, (7/32", 5.6mm), 64, (1/4", 6.4mm). Recommended speed, depending on application is up to 6500 R.P.M..
- CS122K02 COVERSEAM. Same as Style CS122K01 except Adjustable, split seam guide, for medium to heavy weight knit garments. Standard gauges 56, (7/32", 5.6mm), 64, (1/4", 6.4mm).



STYLES OF MACHINES (CONT.)

- CS132K01 COVERSEAM. Same as Style CS122K01 except top and bottom coverstitch. Seam Specifications 602 SSh-2. - Typical Application - for light to medium fabrics.
- CS132K02 COVERSEAM. Same as Style CS122K02 except Seam Specification 602 SSh-2.

ILLUSTRATIONS

This manual has been arranged to simplify ordering repair parts. Exploded views of various sections of the mechanism are shown so that the parts may be seen in their actual position in the machine. On the page opposite the illustration will be found a listing of the parts with their part numbers, description and the number of pieces required in the particular view being shown.

Numbers in the first column are reference numbers only, and merely indicate the position of the part in the illustration. The reference number should never be used in ordering parts. Always use the part number listed in the second column.

Component parts of sub-assemblies which can be furnished for repairs are indicated by indenting their descriptions under the description of the main sub-assembly. As an example refer to the following text.

- | | | | |
|----|-------------|---|---|
| 5. | 50366B | Needle Thread Strike-Off Assembly | 1 |
| 6. | 50358V | Needle Thread Strike-Off | 1 |
| 7. | 50370F | Thread Strike-Off Component | 1 |
| 8. | SS7060310SP | Screw, for plate strike-off | 1 |

When a part is common to all machines covered in this manual, no specific usage will be mentioned in the description. However, when the parts for the various machines are not the same, the specific usage will be mentioned in the description and, if necessary, the difference will be shown in the illustration.

*NOTE: Ref. No. showing no Part No. is for location only. Part is not for sale separately.

A numerical index of all the parts shown in this manual is located at the back. This will facilitate locating the illustration and description when only a part number is known.

IDENTIFYING PARTS

Where construction permits, each part is stamped with its part number. On some of the smaller parts and on those where construction does not permit, an identification letter is stamped in to distinguish the part from similar ones.

PLEASE NOTE: Part numbers represent the same part, regardless of which manual they appear. On all orders please include part number, name and style of machine for which the part was ordered.

For optimum performance use only genuine Union Special replacement parts.

NEEDLES

Each needle has both a type and size number. The type number denotes the kind of shank, point, length, groove, finish and other details. The size number, stamped on the needle shank, denotes the largest diameter of the blade measured between the shank and the eye. Collectively, the type number and size number represent the complete symbol which is given on the label of all needles packed and sold by Union Special.

<u>TYPE</u>	<u>DESCRIPTION</u>
121 GJS	Short, double groove, struck groove, ball eye, spotted, ball point, chromium plated- Sizes available 055/022, 065/025, 070/027, 075/029, 080/032, 090/036.

When changing the needle, make sure it is fully inserted in the holder before the screw is tightened.

When ordering needles, please use the complete type and size numbers as printed on the package to ensure prompt and accurate processing of your order. A complete order should read as follows: "100 needles, type 121 GJS, size 075/029".



SAFETY RULES

1. Before putting the machines described in this manual into service, carefully read the instructions. The starting of each machine is only permitted after taking notice of the instructions and by qualified operators.

IMPORTANT! Before putting the machine into service, also read the safety rules and instruction from the motor supplier.

2. Observe the national safety rules valid for your country.
3. The sewing machines described in this instruction manual are prohibited from being put into service until it has been ascertained that the sewing units which these sewing machines will be built into, have conformed with the EC Council Directives (89/392/EEC, Annex II B).

Each machine is only allowed to be used as foreseen. The foreseen use of the particular machine is described in paragraph "STYLES OF MACHINES" of this instruction manual. Another use, going beyond the description, is not as foreseen.

4. All safety devices must be in position when the machine is ready for work or in operation. Operation of the machine without the appertaining safety devices is prohibited.
5. Wear safety glasses.
6. In case of machine conversions and changes all valid safety rules must be considered. Conversions and changes are made at your own risk.
7. The warning hints in the instructions are marked with one of these two symbols:

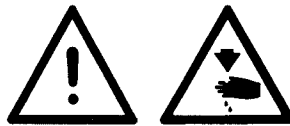

8. When doing the following the machine has to be disconnected from the power supply by turning off the main switch or by pulling out the main plug:
 - 8.1 When threading needle(s), looper, spreader etc.
 - 8.2 When replacing any parts such as needle(s), presser foot, throat plate, looper, spreader, feed dog, needle guard, folder, fabric guide etc.
 - 8.3 When leaving the workplace and when the workplace is unattended.
 - 8.4 When doing maintenance work.
 - 8.5 When using clutch motors without actuation lock, wait until the motor is stopped totally.
9. Maintenance, repair and conversion work (see item 8) must be done only by trained technicians or special skilled personnel under consideration of the instructions.
10. Any work on the electrical equipment must be done by an electrician or under direction and supervision of special skilled personnel.
11. Work on parts and equipment under electrical power is not permitted. Permissible exceptions are described in the applicable sections of standard sheet DIN VDE 0105.
12. Before doing maintenance and repair work on the pneumatic equipment, the machine has to be disconnected from the compressed air supply. In case of existing residual air pressure after disconnecting from compressed air supply (i.e. pneumatic equipment with air tank), the pressure has to be removed by bleeding.



CS100 SERIES BUILDING BLOCK STYLE DESIGNATION SYSTEM

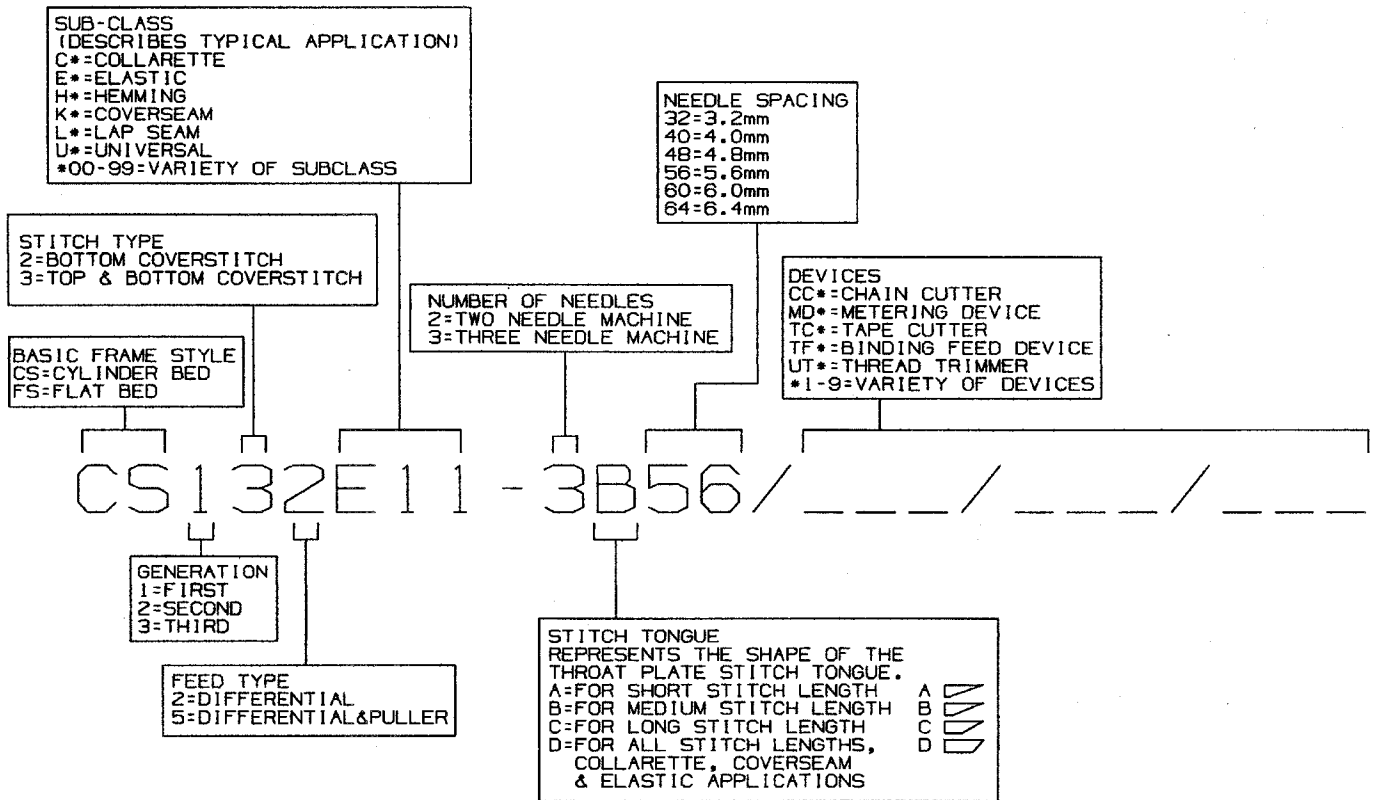

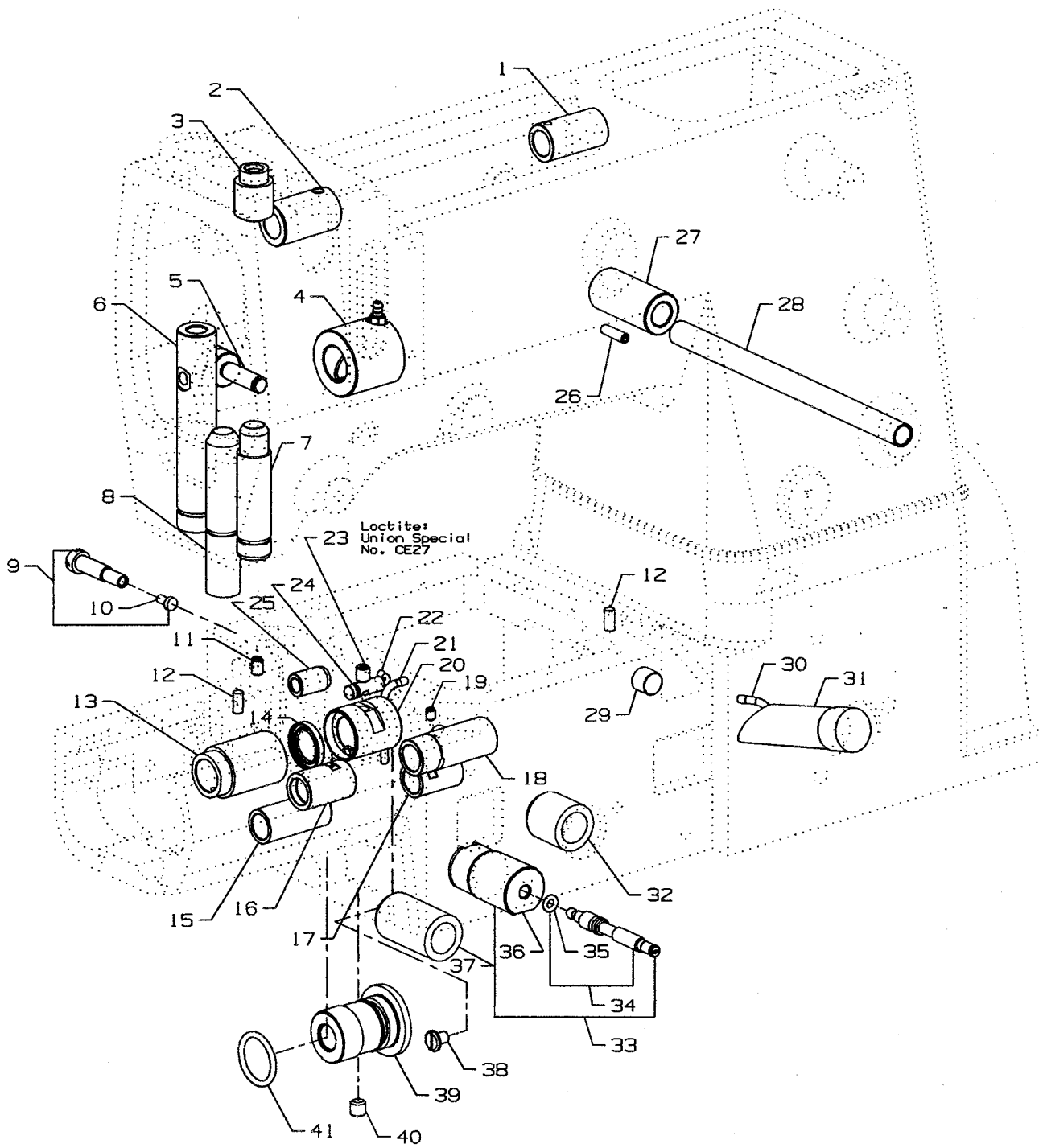

BUSHINGS

Ref. No.	Part No.	Description	Amt. Req.
1.	50347E	Bushing, for spreader, rear	1
2.	50347F	Bushing, for spreader, front	1
3.	50354J	Bushing, for needle bar, upper	1
4.	50344BU	Bushing, for upper main shaft, front	1
5.	50332U	Pin	1
6.	50347L	Bushing, for spreader drive	1
7.	50354H	Bushing, for needle bar, lower	1
8.	50330CZ	Bushing, for presser bar	1
9.	99352	Stop Screw	2
10.	999-212-035	Stop	1
11.	22894BD	Screw, for cast-off plate stud	1
12.	96841	Pin	1
13.	34390	Bushing, for main shaft, left	1
14.	50393EZ	Oil Seal	1
15.	34336C	Bushing, for feed rocker, left	1
16.	34336D	Bushing, for feed lifter shaft, left	1
17.	34336B	Bushing, for feed rocker shaft, right	1
18.	34336E	Bushing, for feed lifter shaft, right	1
19.	22565C	Set Screw	1
20.	50344BP	Bushing, for main shaft, middle	1
21.	34394A	Oil Tube	1
22.	50393KW	Oil Tube	1
23.	22894AD	Screw	1
24.	999-211B	"O" Ring	1
25.	50344BL	Bushing, for cast-off plate bracket	1
26.	PS0400142KH	Pin	1
27.	50381E	Bushing, for lifter lever, back	1
28.	50392AB	Bushing, for tension release	1
29.	22571F	Plug Screw	2
30.	34394B	Oil Tube	1
31.	50393GF	Oil Sight Gauge	1
32.	34342G	Bushing, for looper drive shaft, front	1
33.	50344BN	Differential Feed Adjusting Assembly	1
34.	50322AZ	Differential Feed Adjusting Shaft	1
35.	RO037180100	"O" Ring	1
36.	50344BK	Differential Adjusting Bushing	1
37.	34342F	Bushing, for looper drive shaft rear	1
38.	22829	Screw	1
39.	50344AV	Bushing	1
40.	SS8660612TP	Screw	1
41.	999-211	"O" Ring	1



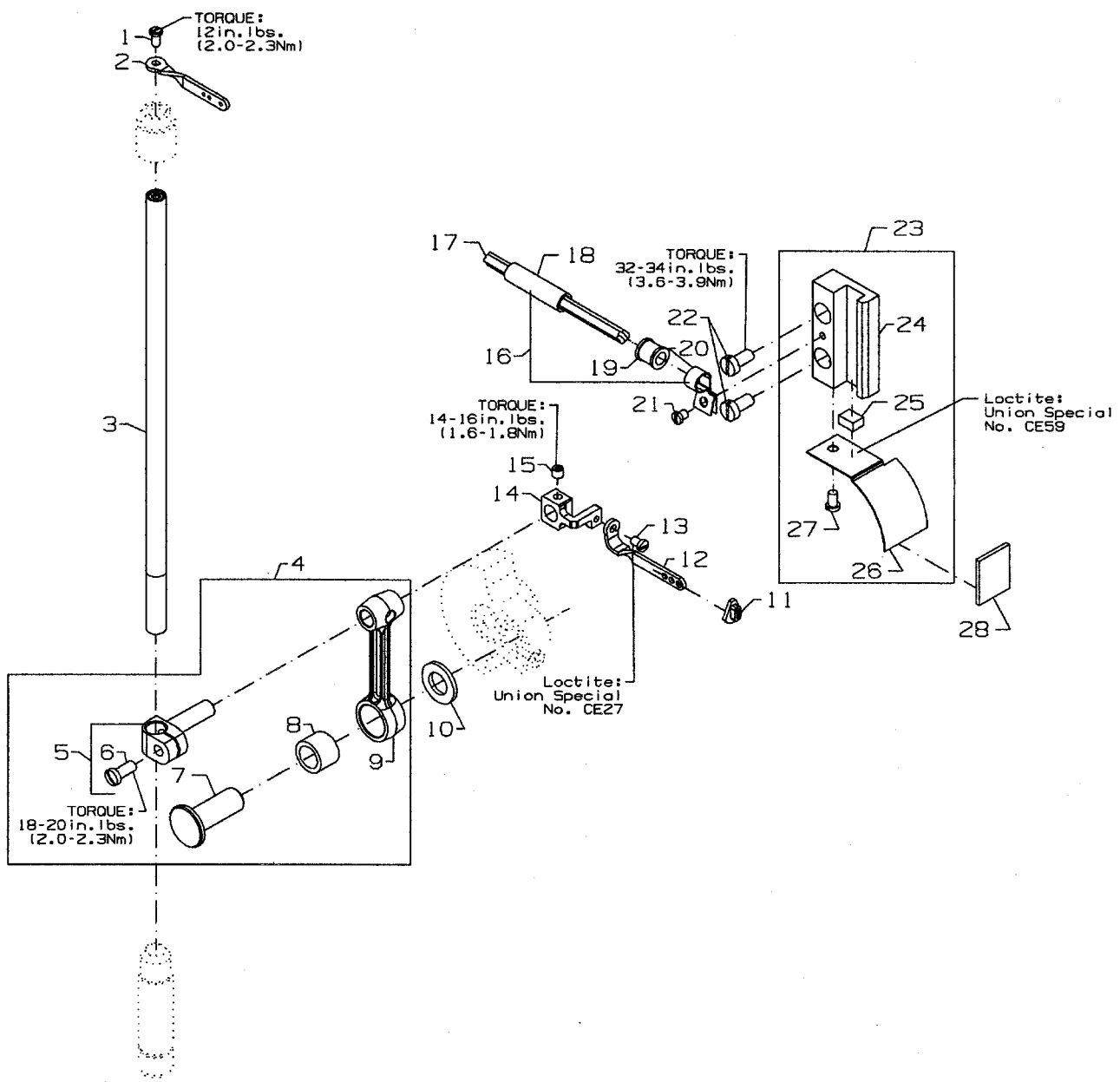

NEEDLE BAR

Ref. No.	Part No.	Description	Amt. Req.
1.	SS4080620TP	Screw	1
2.	50323P	Needle Bar Eyelet	1
3.	50317B	Needle Bar	1
4.	50345W	Connecting Rod Assembly	1
5.	50355AM	Needle Bar Clamp	1
6.	SS7111120TP	Screw	1
7.	50352	Pivot Pin	1
8.	661-259B	Needle Bearing Cage	1
9.	50355AN	Connecting Rod	1
10.	50351A	Washer	1
11.	50393JP	Eyelet Seal	1
12.	50358X	Needle Thread Eyelet	1
13.	SS7080520SP	Screw	1
-	CE27	Loctite Adhesive, (not shown), for screw	-
14.	50354F	Slide Block	1
-	CE63	Three Bond Adhesive, (not shown), for slide block	-
15.	SS8110422TP	Screw	1
16.	29476TC	Oil Tube Assembly	1
17.	CQ25220000	Wick	1
18.	50393JY	Oil Tube	1
19.	50393JZ	Oil Tube	1
20.	50393JW	Hose Clamp	1
21.	SS6090440SP	Screw, for support bracket	1
22.	SS6121010SP	Screw	2
23.	29476TH	Slide Block Guide Assembly	1
24.	50354G	Slide Block Guide	1
-	50393HS	Sponge	1
25.	CE59	Loctite Adhesive, (not shown), for sponge	-
26.	50394AF	Slide Block Guide Cover	1
27.	SS6090620SP	Screw	1
28.	666-329	Felt	1



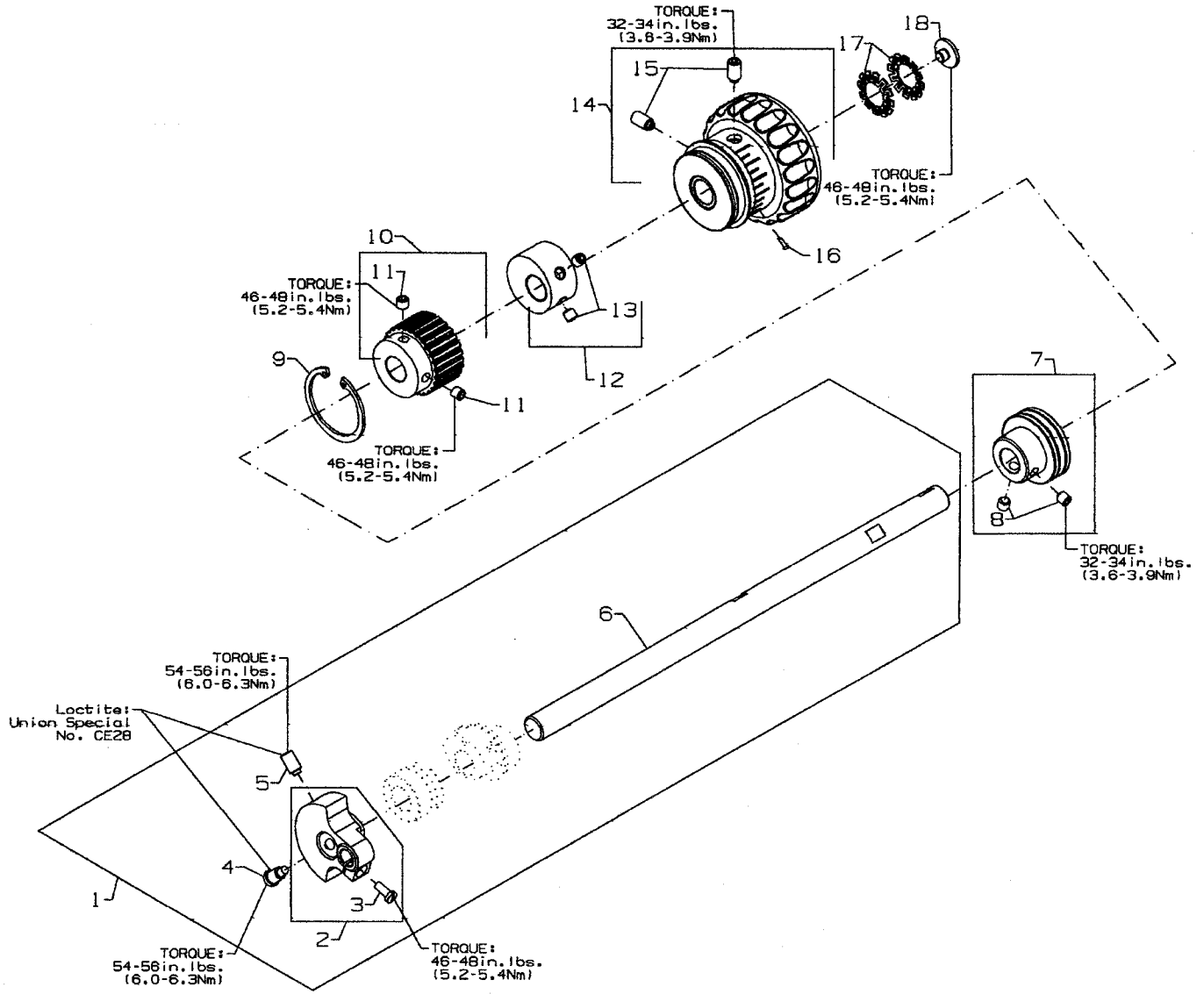

UPPER MAIN SHAFT

Ref. No.	Part No.	Description	Amt. Req.
1.	50322BB	Upper Main Shaft Assembly	1
2.	50391	Counter Weight	1
3.	SS7111120TP	Screw, for counter weight	1
4.	SS7681410TP	Screw, for counter weight	1
5.	SS8681412TP	Screw, for counter weight	1
6.	50322AF	Upper Main Shaft	1
7.	50335BD	Bearing Adapter Assembly	1
8.	SS8660612TP	Screw, for bearing adapter	2
9.	661-262	Retaining Ring	1
10.	50342AY	Sprocket, for upper main shaft	1
11.	SS8661012TP	Set Screw, for sprocket	2
12.	50391A	Counterweight	1
13.	SS8660612TP	Screw	2
14.	50321M	Handwheel	1
15.	SS8681412TP	Set Screw, for handwheel	2
16.	660-1043	Tack Pin, for hand wheel	1
17.	661-261	Load Ring, for lower main shaft	2
18.	SS7660520SP	Screw, for handwheel preload	1



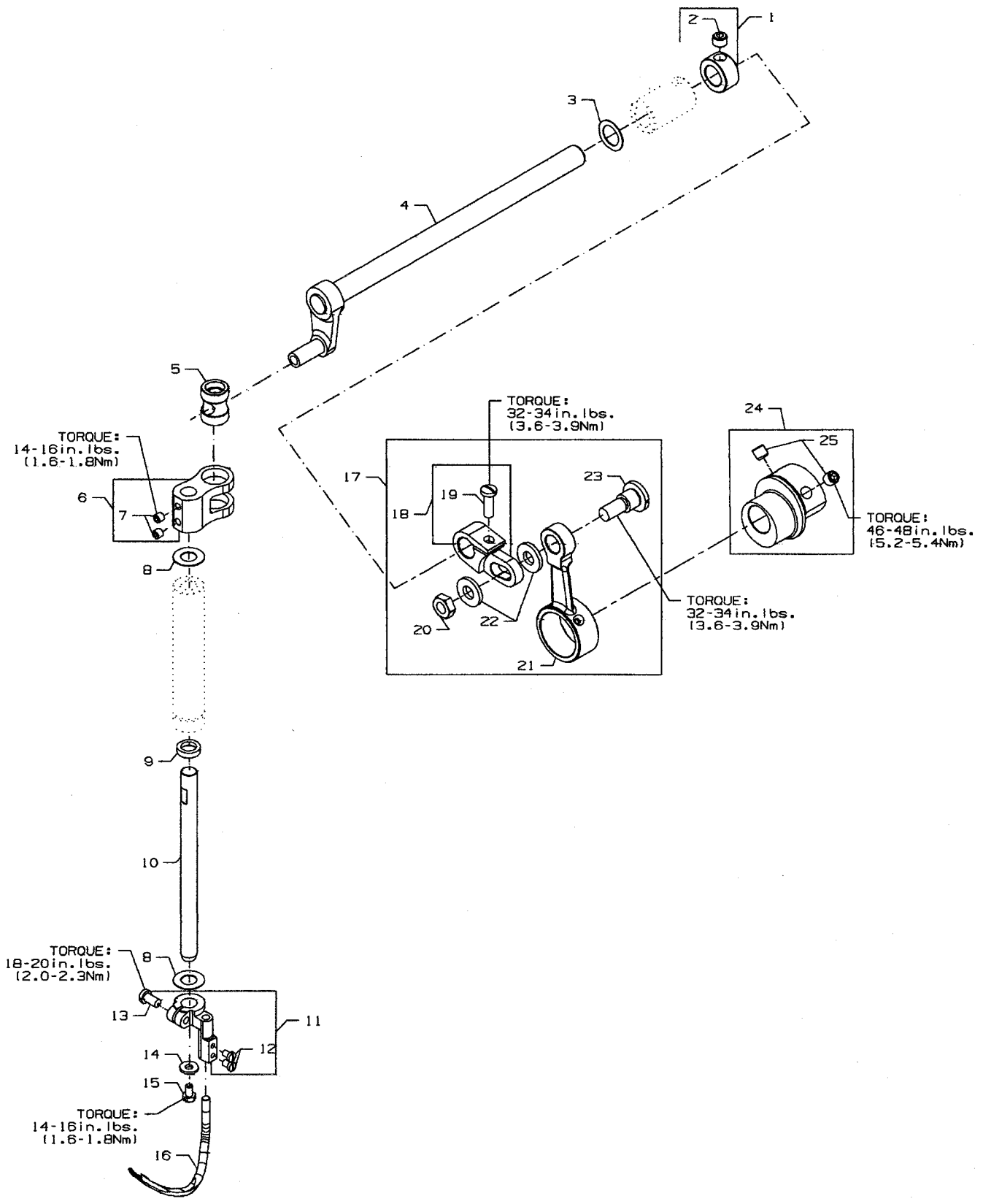

SPREADER

Ref. No.	Part No.	Description	Amt. Req.
1.	50335AW	Collar, for spreader shaft	1
2.	SS8660512TP	Set Screw	1
3.	96162B	Washer	1
4.	50360B	Crankshaft, for spreader assembly	1
5.	50347J	Pin, for spreader rocker	1
6.	50347C	Lever, for spreader holder shaft	1
7.	SS8110422TP	Screw	2
8.	61351C	Washer	2
9.	660-739	Oil Seal	1
10.	50347G	Shaft, for spreader, vertical	1
11.	50346A	Spreader Holder	1
12.	SS7080510TP	Screw	2
13.	SS7110910TP	Screw	1
14.	53678N	Washer	1
15.	SS9090640SP	Hex Screw, for vertical shaft	1
16.	50360H	Spreader	1
17.	29126FW	Spreader Crank Rod Assembly	1
18.	50360G	Spreader Shaft Driving Arm	1
19.	SS7121410TP	Screw	1
20.	NS6680410SP	Hex Nut, for spreader drive	1
21.	50360F	Connecting Rod, for spreader drive	1
22.	WP0742016SP	Collar, for spreader driving arm	2
23.	SD1000801SH	Stud	1
24.	50360	Eccentric, for spreader drive	1
25.	SS8660612TP	Screw	2



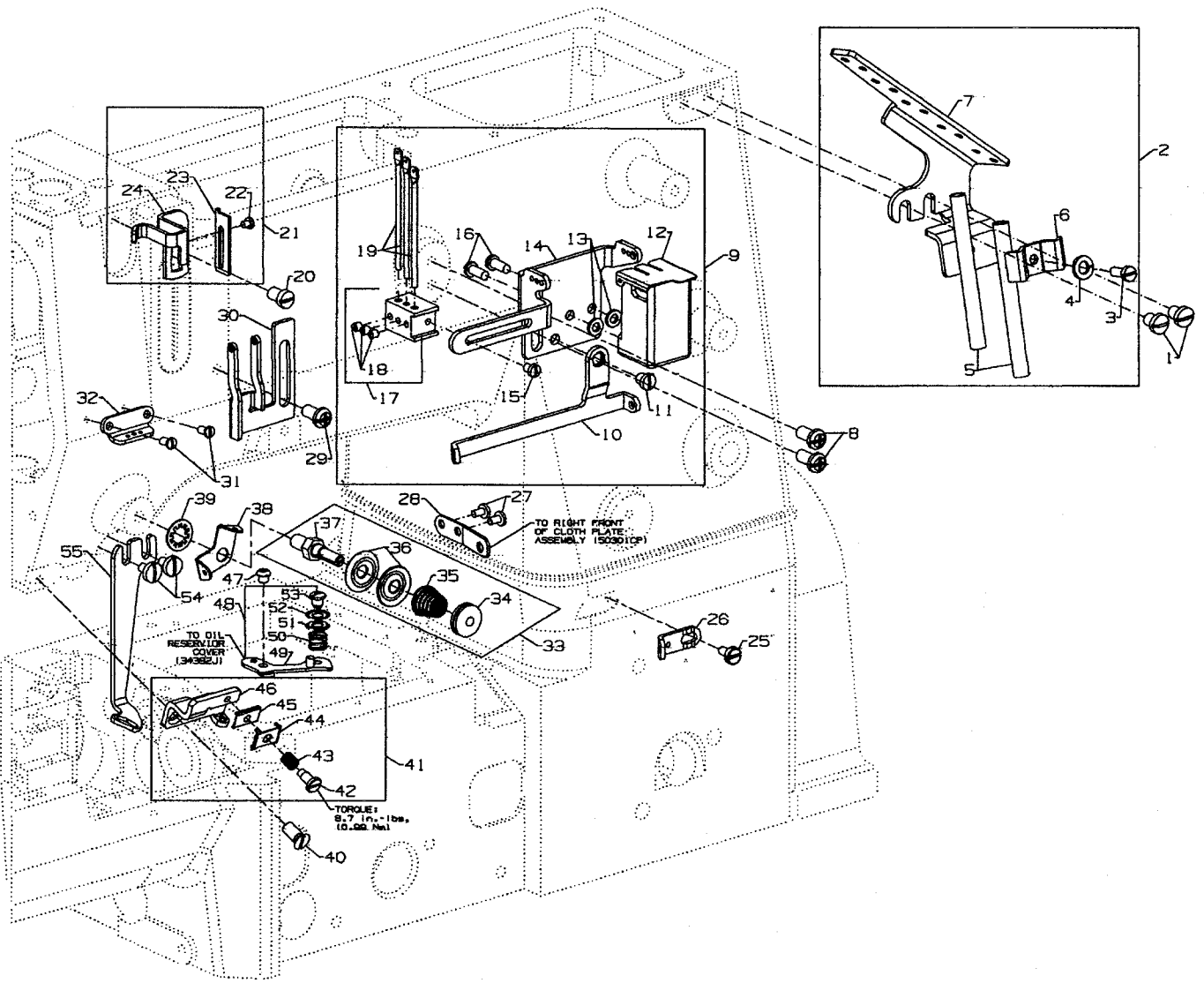

THREAD GUIDE

Ref. No.	Part No.	Description	Amt. Req.
1.	SS7120640SP	Screw, for lead-in eyelet	2
2.	50392AU	Thread Eyelet Assembly	1
3.	SS7090910TP	Screw, for tube bracket	1
4.	WS0510002KP	Washer	1
5.	50366	Thread Eyelet Tube	2
6.	50366A	Thread Eyelet Tube Bracket	1
7.	50392S	Lead-in Tension Eyelet	1
8.	SS4120615SP	Screw, for spreader thread guide	2
9.	50363CK	Needle Thread Guide & Lubricator Assembly	1
10.	50358U	Thread Guide, for spreader	1
11.	SS7110410SP	Screw, for needle thread guide	1
12.	50393HH	Silicone Thread Lubricator	1
13.	WS0371026SD	Washer	2
14.	50366J	Needle Thread Guide	1
15.	SS7080510TP	Screw, for holder eyelet	1
16.	SS4090815SP	Screw, for silicone tank	2
17.	50358W	Holder, for needle thread eyelet	1
18.	SS8080410TP	Screw	3
19.	36271A	Adjusting Needle Thread Eyelet	3
20.	SS7120710SP	Screw, for strike-off	1
21.	50366B	Needle Thread Strike-Off Assembly	1
22.	SS7060310SP	Screw, for plate strike-off	1
23.	50370F	Thread Strike-Off Component	1
24.	50358V	Needle Thread Strike-Off	1
25.	98A	Screw	1
26.	12124202	Looper Frame Eyelet	1
27.	87U	Screw	1
28.	34358F	Looper Thread Guide	1
29.	SS4120915SP	Screw, for thread take-up cover	1
30.	50392T	Eyelet	1
31.	605A	Screw, for needle thread guide	2
32.	C50044E	Needle Thread Guide	1
33.	29475CG	Spreader Thread Tension Assembly	1
34.	50392AZ	Tension Nut	1
35.	50392AY	Tension Spring	1
36.	50392AX	Tension Disc	2
37.	50392AW	Tension Post	1
38.	57844	Eyelet	1
39.	652C16	Star Washer	1
40.	SS1121010SP	Screw, for thread guide	1
41.	50357AR	Nipper Plate Assembly	1
42.	SD0380551SL	Shoulder Screw	1
43.	50357AS	Nipper Spring	1
44.	50357Y	Nipper Spring Plate	1
45.	50357V	Nipper Plate	1
46.	50366G	Thread Guide	1
47.	18C1471	Screw	2
48.	29480AYJ	Looper Thread Nipper	1
49.	50366L	Eyelet	1
50.	50357AV	Spring, Nipper	1
51.	50357AT	Nipper Plate	1
52.	50357AX	Nipper Plate	1
53.	50357AW	Screw, Tension Post	1
54.	SS7090610SP	Screw, for spreader thread guide	2
55.	50346	Thread Guide Spreader	1



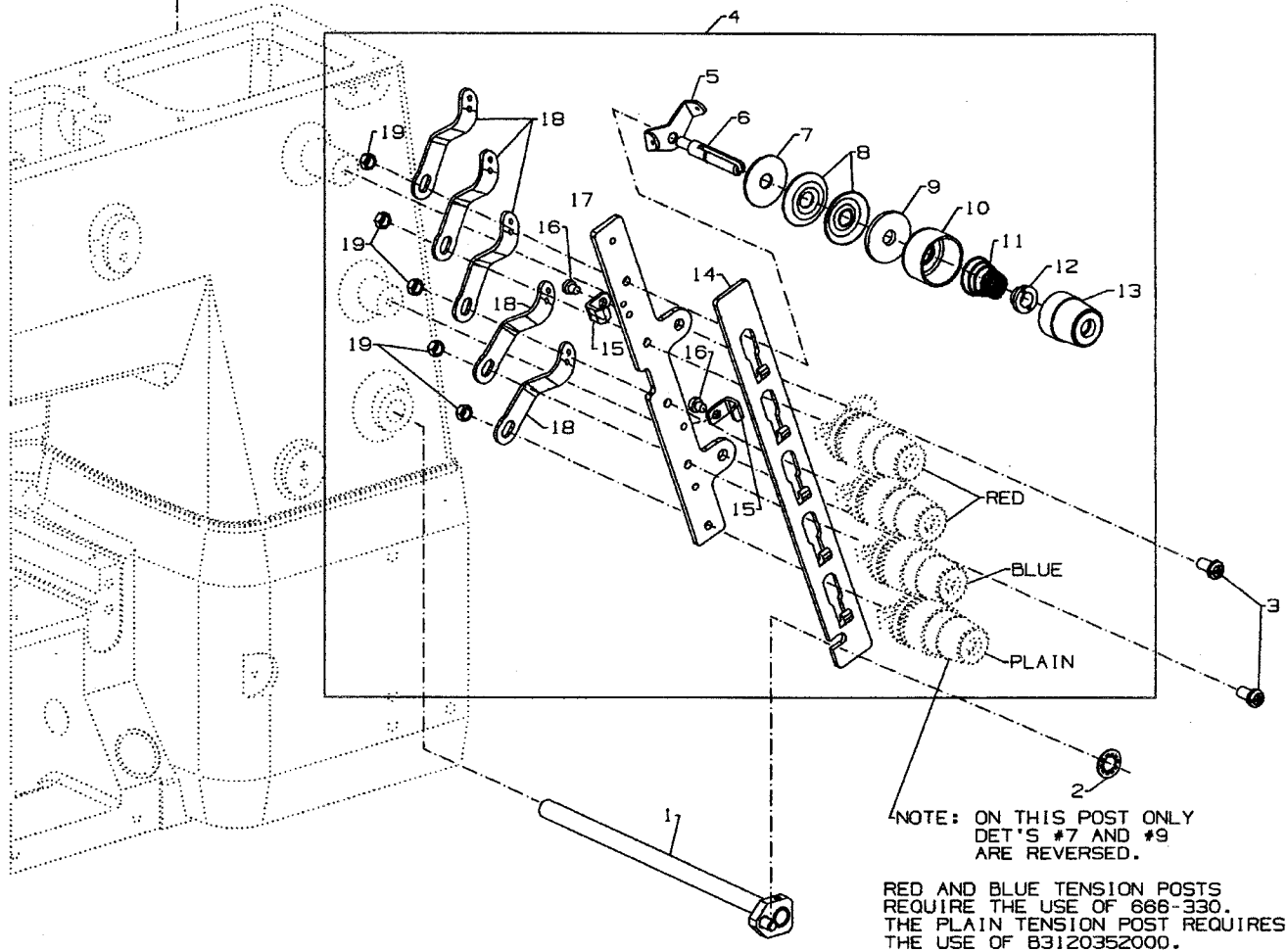
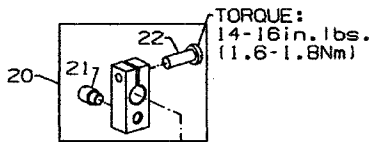

TENSION RELEASE & THREAD TENSION

Ref. No.	Part No.	Description	Amt. Req.
1.	50392Z	Tension Needle Lever Assembly	1
2.	660-283A	Retainer Washer	1
3.	SS4120915SP	Screw, for tension assembly	2
4.	50392Y	5 Thread Tension Assembly	1
5.	57892K	Thread Tension Eyelet	5
6.	56392G	Tension Post	5
7.	B3120352000	Tension Disc Felt	1
-	666-330	Disc Felt	4
8.	B3126012000	Tension Disc	10
9.	B3120704000	Tension Disc Felt	5
10.	56392H	Spring Shield	5
11.	11550209	Spring, needle (green)	3
-	B3103804000	Spring, spreader (blue)	1
-	B3121804000	Spring, looper (plain)	1
12.	B3112704000	Ferrule, tension spring	5
13.	50692G	Knob, needle (green)	3
-	56392M	Knob, spreader (blue)	1
-	56392R	Knob, looper (plain)	1
14.	50392W	Tension Disc Separator	1
15.	50392AV	Guide, for tension disc separator	2
16.	SS7090520SP	Screw, for guide	2
17.	50392X	Tension Bracket	1
18.	57865	Lead-In Thread Guide	5
19.	NS6110420SP	Nut	5
20.	50392BC	Tension Release Lever Shaft Connection	1
21.	22875N	Base Spring Screw	1
22.	SS7121410TP	Binder Screw	1



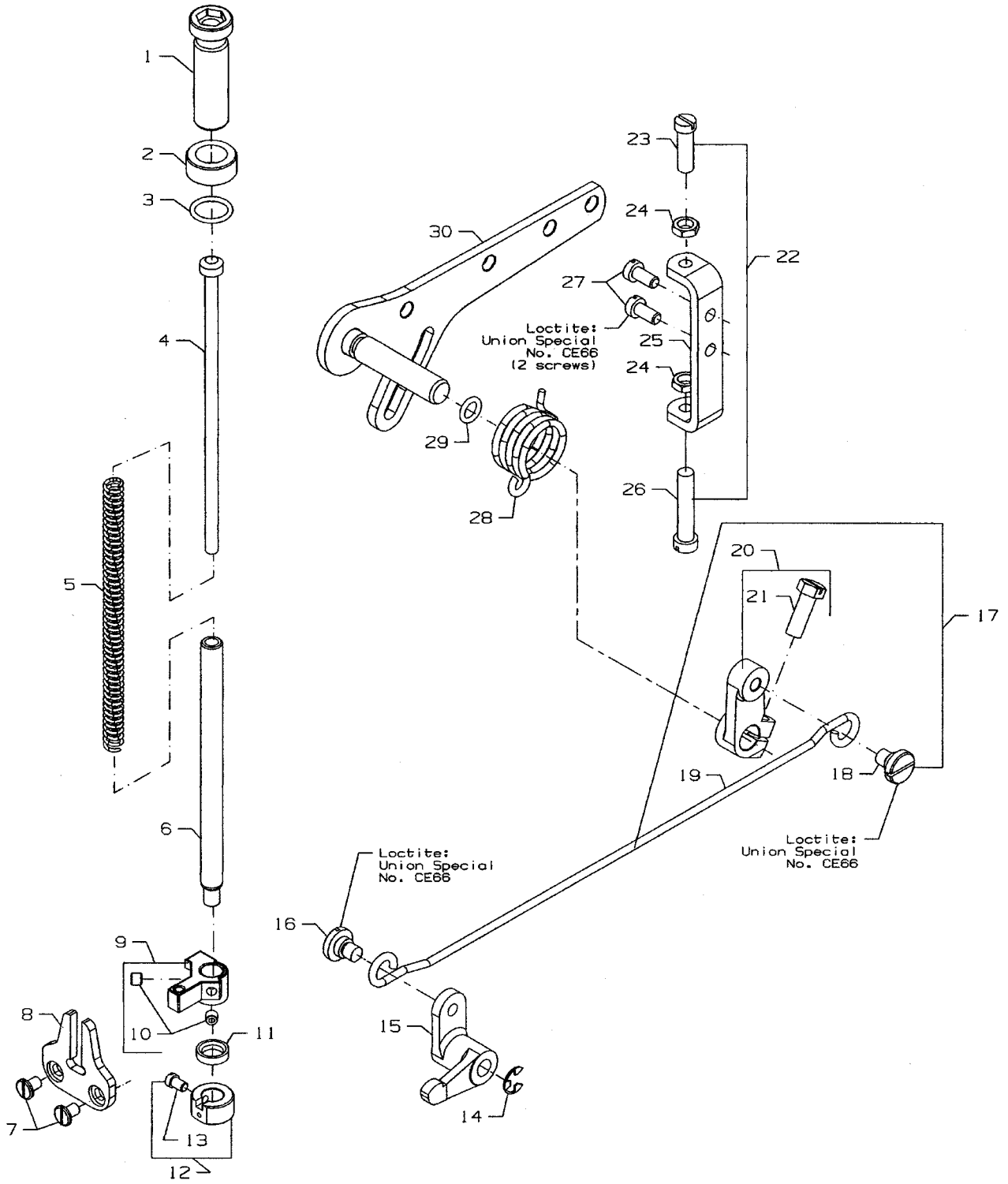

PRESSER FOOT LIFT

Ref. No.	Part No.	Description	Amt. Req.
1.	11071602	Adjusting Screw, for spring	1
2.	11071701	Locking Nut	1
3.	660-1014	"O" Ring	1
4.	C50056B	Spring Rod	1
5.	50357AP	Spring, for presser bar	1
6.	50335AF	Presser Bar	1
7.	SS6110610TP	Screw, for guide plate	2
8.	50335AG	Guide Plate, for presser bar	1
9.	50335AH	Presser Bar Guide	1
10.	SS8110422TP	Set Screw	2
11.	660-739	Oil Seal	1
12.	50333P	Collar	1
13.	22562	Screw	2
14.	RE0500000K0	E Ring, for pin	1
15.	50381F	Lever, for lifter, front	1
16.	SD0790303SP	Screw, for wire connector	1
-	CE66	Loctite Adhesive, (not shown), for screw	-
17.	29476TK	Rear Lifter Lever Assembly	1
18.	SD0790303SP	Screw	1
19.	50355AR	Wire Connector	1
20.	50381G	Lifter Lever, rear	1
21.	SS9151740CP	Hex Screw	1
22.	29476TT	Stop Assembly	1
23.	SS6151920SP	Screw, for stopper	1
24.	NS6150310SP	Hex Nut	2
25.	50332V	Stopper, for lifter lever	1
26.	SS6153040SP	Screw, for adjusting stopper	1
27.	SS6121010SP	Screw, for adjusting stopper	2
-	CE66	Loctite Adhesive, (not shown), for screw	-
28.	50381	Spring, for lifter lever	1
29.	RO068190100	"O" Ring	1
30.	50381B	Lifter Lever Assembly	1



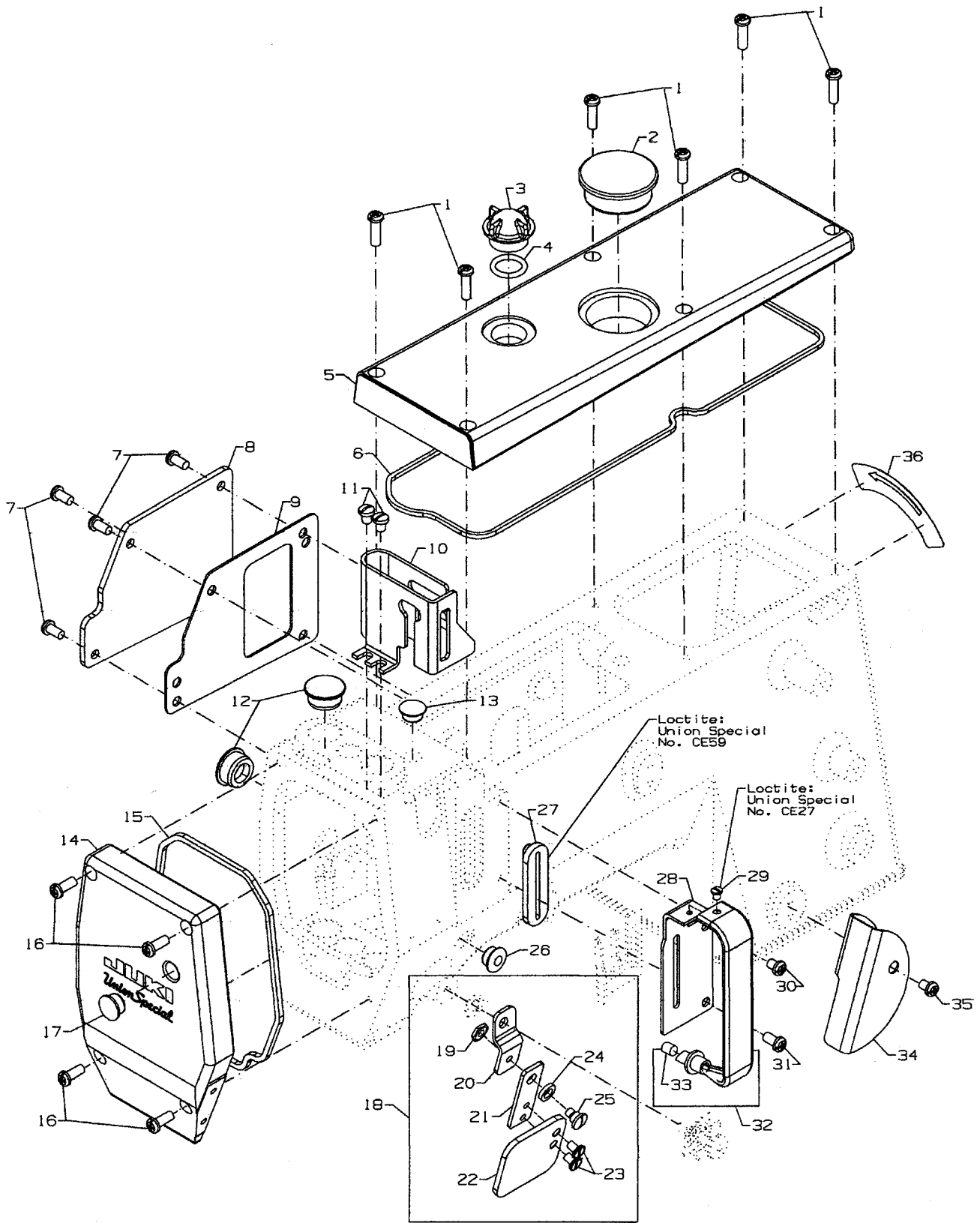

COVERS, UPPER ARM

Ref. No.	Part No.	Description	Amt. Req.
1.	SS4121615SP	Screw, for top cover	6
2.	50393EU	Plug, for top cover	1
3.	B3530555000	Oil Sight Gauge, top	1
4.	660-212	"O" Ring, for oil sight gauge	1
5.	50382FW	Top Cover	1
6.	50382FZ	Quad Ring, for top cover	1
7.	SS4120915SP	Screw, for puller drive cover	4
8.	50382GB	Puller Drive Cover	1
9.	50384L	Gasket, for puller drive cover	1
10.	50317C	Needle Bar Guard	1
11.	SS7120640SP	Screw, for needle bar guard	2
12.	50393HB	Plug	2
13.	TA1050504R0	Plug, for arm	1
14.	50382FX	Head Cover	1
15.	50382FY	Quad Ring, for head cover	1
16.	SS4121215SP	Screw, for head cover	4
17.	TA1100604R0	Plug	1
18.	99682XCB	Sewing Guard Assembly	1
19.	NS6620320SP	Nut	1
20.	50383AE	Bracket Holder	1
21.	50383AD	Bracket	1
22.	99682XC	Protection Shield	1
23.	SS1110640SL	Counter Sunk Head Screw	2
24.	WZ0641510KP	Spring Washer	1
25.	SD0640323TP	Shoulder Screw	1
26.	50337AW	Plug	1
27.	50393EW	Rubber Gasket, for needle lever	1
28.	50382JL	Thread Take-Up Bracket	1
29.	SS7090530SP	Screw	1
30.	SS4120615SP	Screw, for thread cover	1
31.	SS4120915SP	Screw, for thread take-up cover	1
32.	50382JN	Thread Take-Up Cover	1
33.	666-334	Felt Wick	1
34.	50382GM	Thread Cover	1
35.	SS4120615SP	Screw, for thread cover	1
36.	LA451	Label, in direction of rotation	1



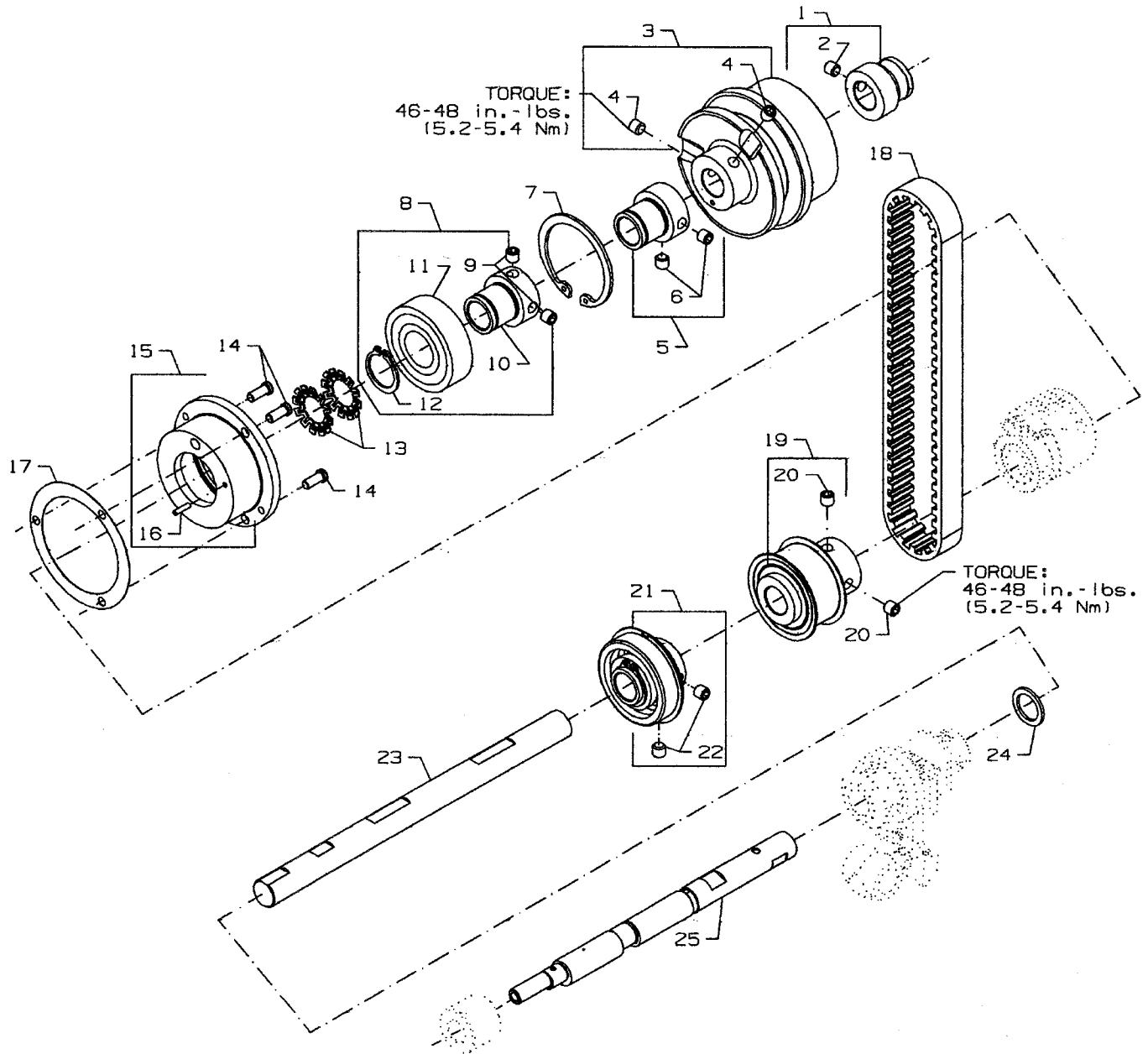

LOWER MAIN SHAFT

Ref. No.	Part No.	Description	Amt. Req.
1.	34321CC	Flange, synchronizer.....	1
2.	95205	Screw	1
3.	50321J	Pulley	1
4.	SS8660612TP	Set Screw	2
5.	50335AP	Adapter	1
6.	SS8660612TP	Screw, for adapter	2
7.	661-348	Retainer Ring	1
8.	50344AR	Bearing Adaptor Assembly	1
9.	SS8660612TP	Screw	2
10.	50335AP	Adaptor	1
11.	50311C	Ball Bearing, for lower main shaft, right	1
12.	50322AN	Retainer, for sprocket	1
13.	661-261	Load Ring	2
14.	22569B	Screw, for housing	3
15.	50390L	Rear Bearing Housing	1
16.	99658	Housing Pin	1
17.	56390E	Housing Gasket	1
18.	50342BD	Timing Belt	1
19.	50342BH	Sprocket, for lower main shaft	1
20.	SS8660612TP	Set Screw	2
21.	50335BC	Bearing Adapter Assembly	1
22.	SS8660612TP	Screw	2
23.	50322AH	Lower Main Shaft, right	1
24.	96162A	Washer	1
25.	50322BG	Mainshaft, left	1



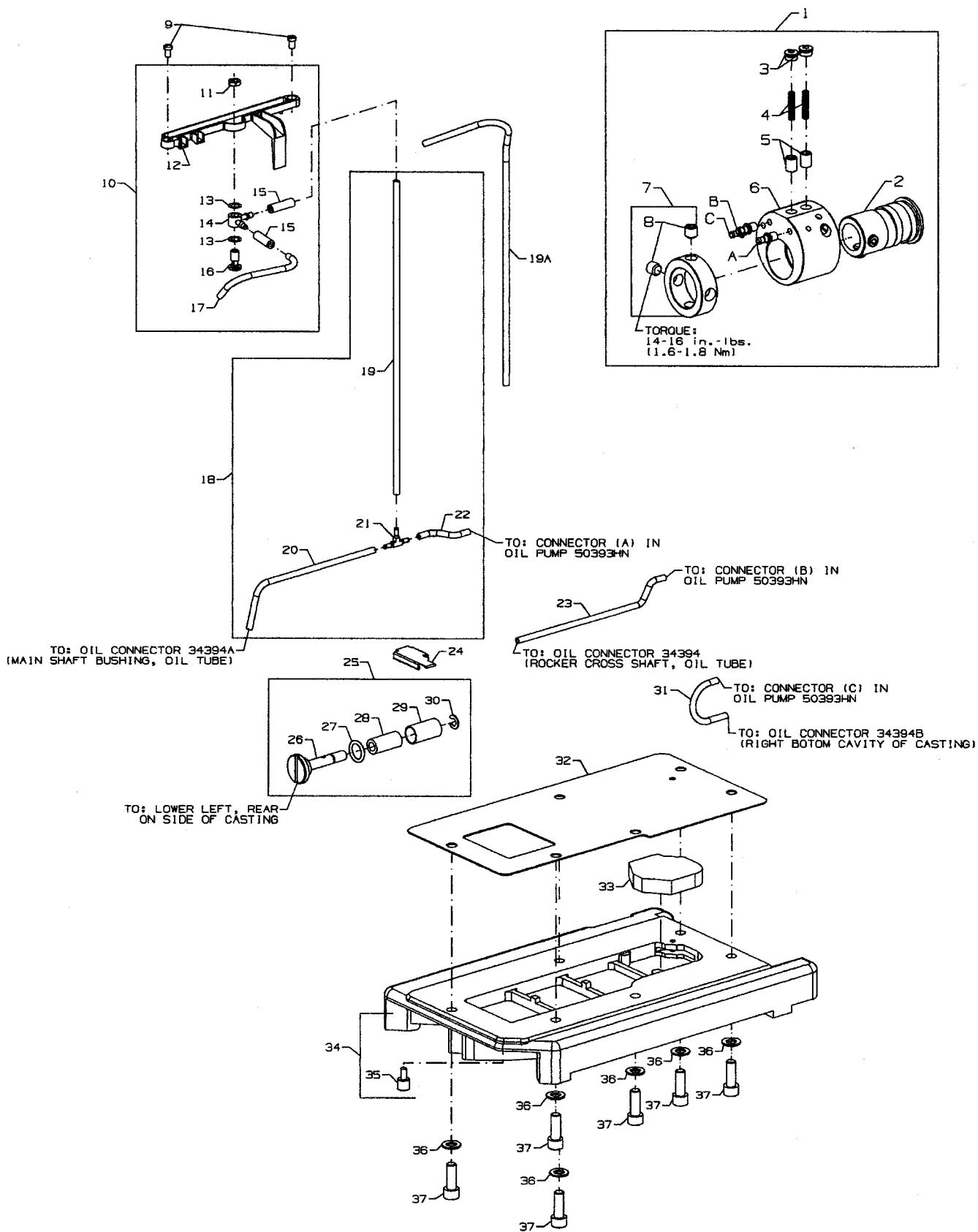

LUBRICATION, OIL TUBING & OIL PUMP

Ref. No.	Part No.	Description	Amt. Req.
1.	50393HN	Oil Pump Assembly, 2 stage	1
2.	50393GD	Oil Pump Housing, 2 Stage	1
3.	18-1470	Screw	2
4.	50332S	Spring, for plunger	2
5.	34393D	Plunger	2
6.	50393GB	Oil Pump Housing, 2 Stage	1
7.	50393EX	Collar	1
8.	SS8660612TP	Screw	2
9.	SS7120710SP	Screw	2
10.	29476TR	Oil Supply Trough Assembly	1
11.	258A	Nut	1
12.	50393FH	Oil Supply Trough	1
13.	41350X	Washer	2
14.	C50094B	Connector Dual Feed	1
15.	50393GT	Oil Tube Cover	2
16.	50393HE	Plug Screw	1
17.	50393FK	Tube	1
18.	29476TS	Oil Supply Trough Assembly for CS122 and CS132	1
-	29476VL	Oil Supply Trough Assembly for CS125 and CS135	1
19.	50393FF	Oil Tube	1
19A.	50393KV	Oil Tube	1
20.	50393FG	Oil Tube	1
21.	50393GU	"T" Connector	1
22.	50393FD	Oil Tube	1
23.	50393FE	Oil Tube	1
24.	50393LA	Oil Screen	1
25.	29476TJ	Oil Filter Assembly	1
26.	99349	Stud	1
27.	660-212	"O" Ring	1
28.	34393M	Oil Screen Felt	1
29.	34393L	Oil Screen	1
30.	96276	Retaining Ring	1
31.	50393HV	Oil Tube	1
32.	34682C	Gasket	1
33.	999-254J	Oil Filter	1
34.	50382GS	Base Plate	1
35.	22571E	Magnet Plug	6
36.	95953	Washer	6
37.	95406	Screw	1



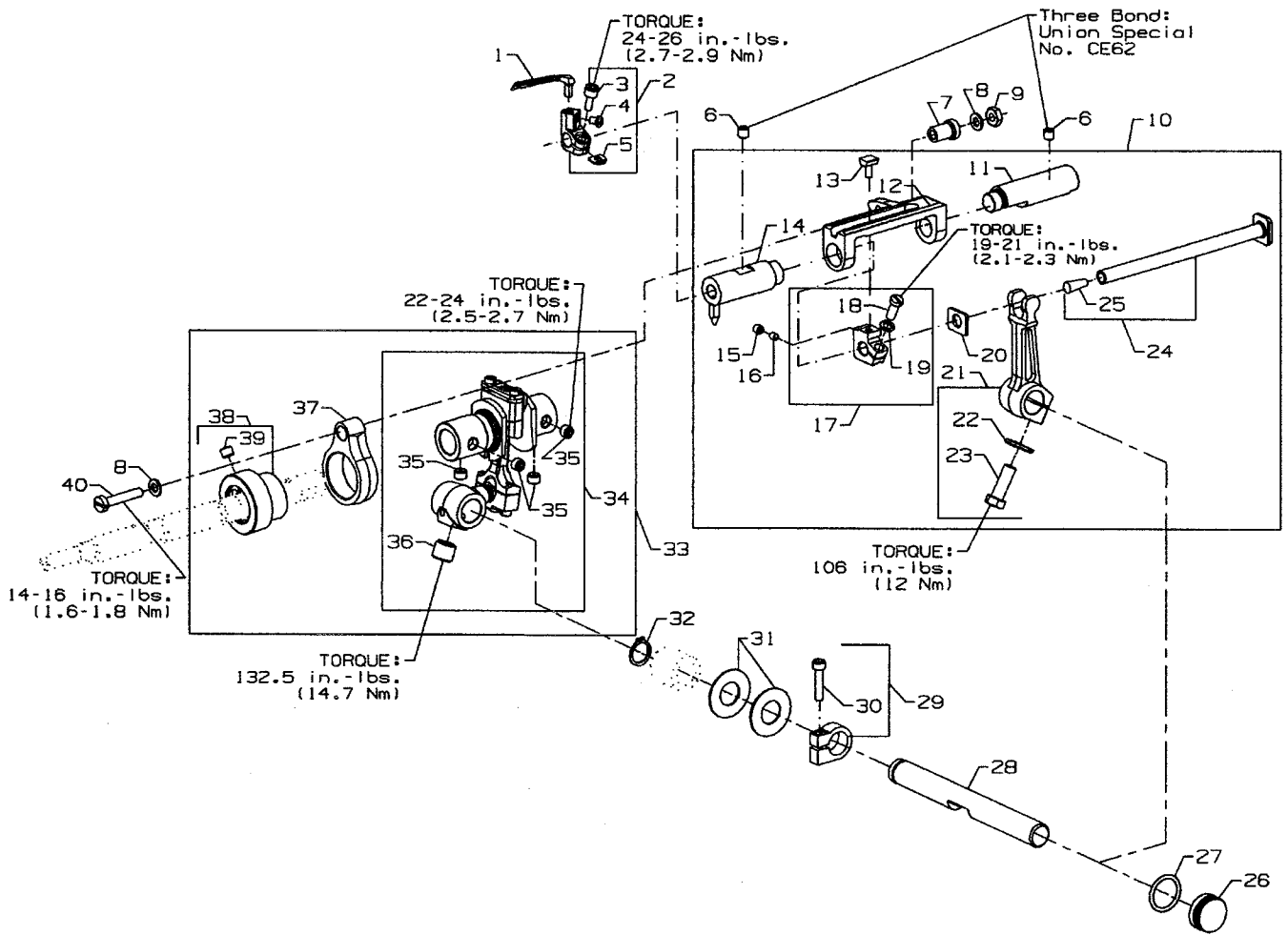

LOOPER DRIVE

Ref. No.	Part No.	Description	Amt. Req.
1.	34709D	Looper	1
2.	50348	Holder, for looper	1
3.	SS6091022TP	Screw	1
4.	SS6090560TP	Screw	1
5.	50313T	Washer	1
6.	22894C	Screw	2
7.	50344AG	Bushing	1
8.	99652A	Washer	2
9.	9937	Nut	1
10.	29476VK	Looper Drive Assembly	1
11.	50343RC	Bushing, for looper bar, right	1
12.	34344A	Cam Guide	1
13.	34344E	Cam Follower	1
14.	50344BM	Bushing, for looper shaft	1
15.	22894W	Screw	1
16.	39543E	Locking Clamp	1
17.	34344D	Cam Guide Holder	1
18.	22541B	Screw	1
19.	51235G	Washer	1
20.	34343C	Washer	1
21.	34642A	Looper Rocker Lever	1
22.	HA20B	Washer	1
23.	22811B	Screw	1
24.	50343B	Shaft, for looper	1
25.	CO67D	Cork	1
26.	34893	Oil Seal Plug, front	1
27.	661-253	"O" Ring	1
28.	50343C	Looper Rocker Shaft	1
29.	34342J	Binder Collar	1
30.	22652A12	Screw	1
31.	56390H	Thrust Washer	2
32.	661-252	Snap Ring	1
33.	29105BK	Looper Eccentric Assembly	1
34.	G29105F	Drive Lever Crank	1
35.	22894X	Screw	4
36.	99346	Set Screw	1
37.	50335BE	Looper Avoid Link	1
38.	50314G	Looper Avoid Eccentric	1
39.	SS8660512TP	Screw	1
40.	99343	Screw	1



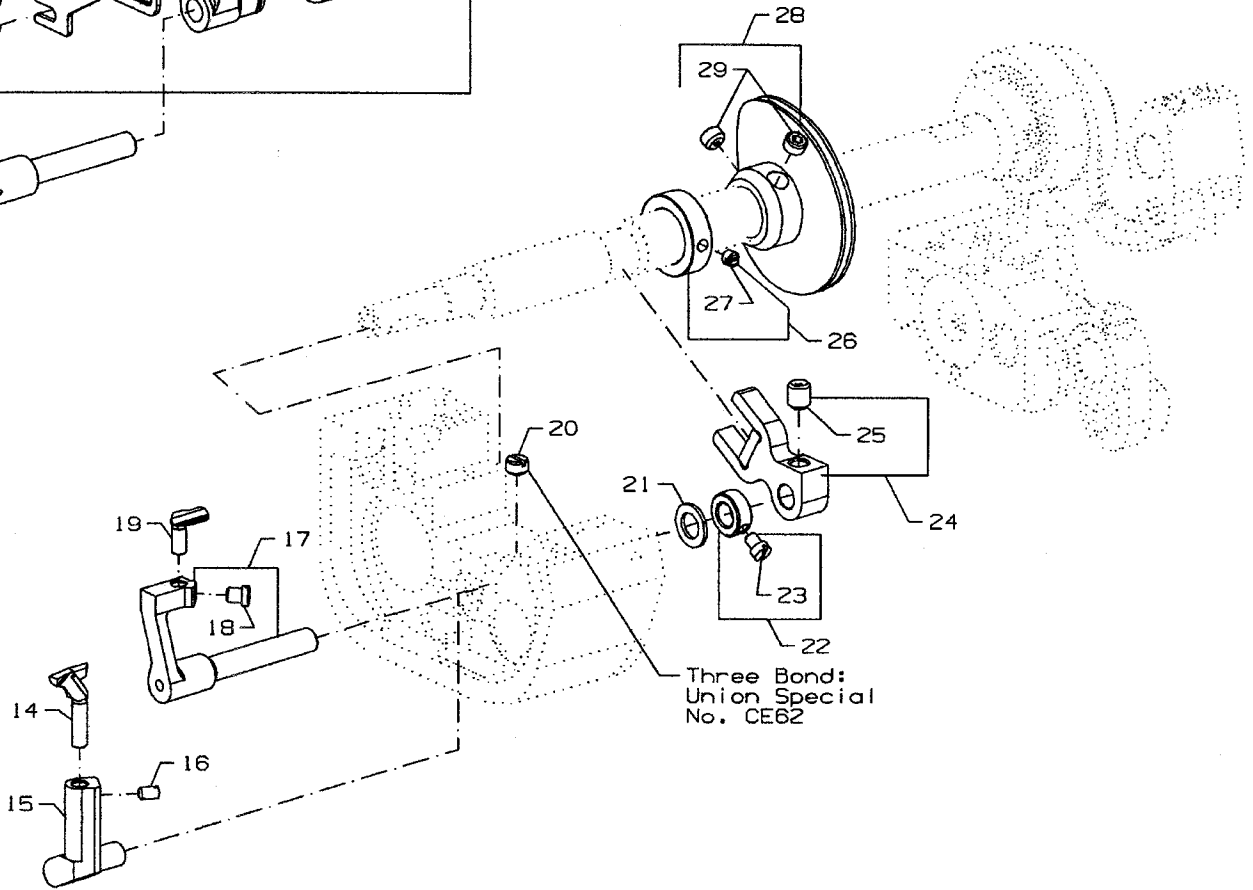
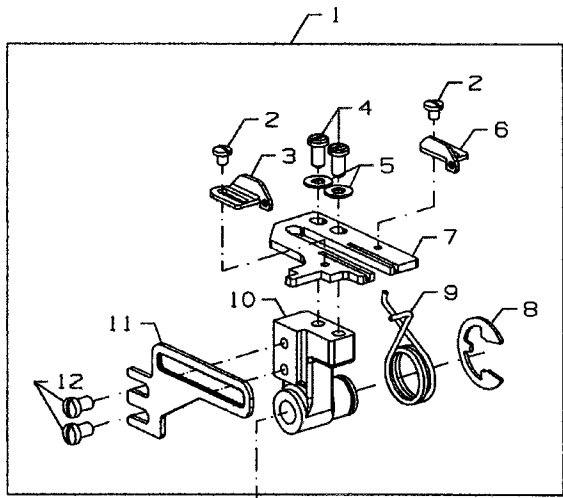

LOOPER THREAD TAKE -UP & NEEDLE GUARD

Ref. No.	Part No.	Description	Amt. Req.
1.	29476UA	Cast-Off Plate Assembly	1
2.	SS7060310SP	Screw	2
3.	34358BA	Thread Guide, left	1
4.	SS4080620TP	Screw	2
5.	WP0320501SC	Washer	2
6.	34358CA	Thread Guide, right	1
7.	50357AK	Cast-Off Plate	1
8.	RE0900000K0	Retaining Ring	1
9.	50357AH	Spring	1
10.	50357AG	Holder	1
11.	50304M	Finger	1
12.	SS7080520SP	Screw	2
13.	50357AJ	Shaft, for cast-off	1
14.	50325AL	Needle Guard, front	1
15.	50325AB	Holder, for needle guard, front	1
16.	SS8090540SP	Screw	1
17.	50325AM	Holder, for needle guard, rear	1
18.	SS6090440SP	Screw	1
19.	50325AN	Needle Guard, rear	1
20.	22580	Screw	1
21.	6042A	Washer	1
22.	50333H	Spacer	1
23.	77A	Screw	1
24.	34368	Fork	1
25.	22894AD	Screw	1
26.	34366	Collar	1
27.	22743	Screw	1
28.	50323S	Take Up	1
29.	22894T	Screw	2



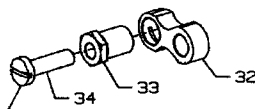
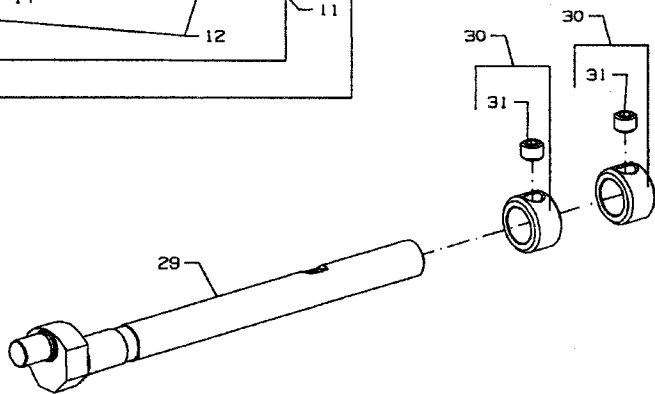
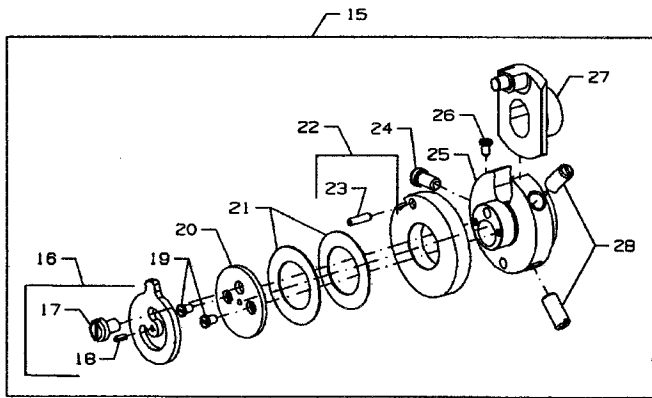
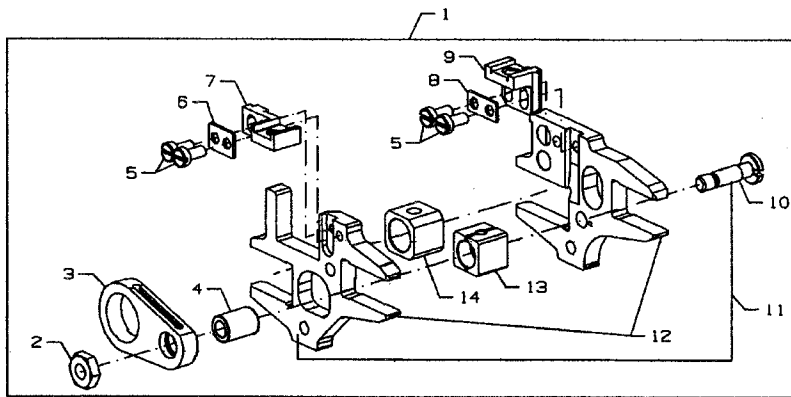

Torque:
20-22 in.-lbs
(2.3-2.5 Nm)

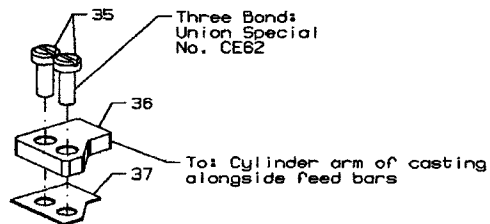

FEED DRIVE MECHANISM

Ref. No.	Part No.	Description	Amt. Req.
1.	G29476BV	Feed Bar Assembly	1
2.	9937	Nut	1
3.	34336N	Drive Connection	1
4.	39536C	Bushing	1
5.	J87J	Screw	4
6.	50386L	Thrust Plate, differential	1
7.	34353A	Differential Feed Dog Holder	1
8.	50386M	Thrust Plate, main	1
9.	34353	Main Feed Dog Holder	1
10.	34336U	Stud	1
11.	29476SH	Feed Bar Assembly	1
12.	34334S	Main and Differential Feed Bar	1
13.	34338	Feed Lift Slide Block	1
14.	34338B	Sliding Block	1
15.	GA29477AP	Eccentric Assembly	1
16.	34336S	Spacing Stop	1
17.	90	Screw	1
18.	96663	Roll Pin	1
19.	22738B	Screw	2
20.	34336RA	Washer	1
21.	97137	Disc Spring	2
22.	34336V	Cam Disc	1
23.	96667	Roll Pin	1
24.	22562A	Screw	1
25.	34336Q	Guide, for eccentric	1
26.	22738B	Screw	1
27.	34340A	Eccentric	1
28.	22503F	Screw	2
29.	50322BF	Feed Lift Shaft	1
30.	34335J	Collar	2
31.	22894X	Set Screw	2
32.	34336A	Differential Feed Drive Link	1
33.	34337F	Eccentric Bushing	1
34.	22874C	Screw	1
35.	93	Screw	2
36.	34335G	Feed Bar Guide	1
37.	34382H	Gasket	1



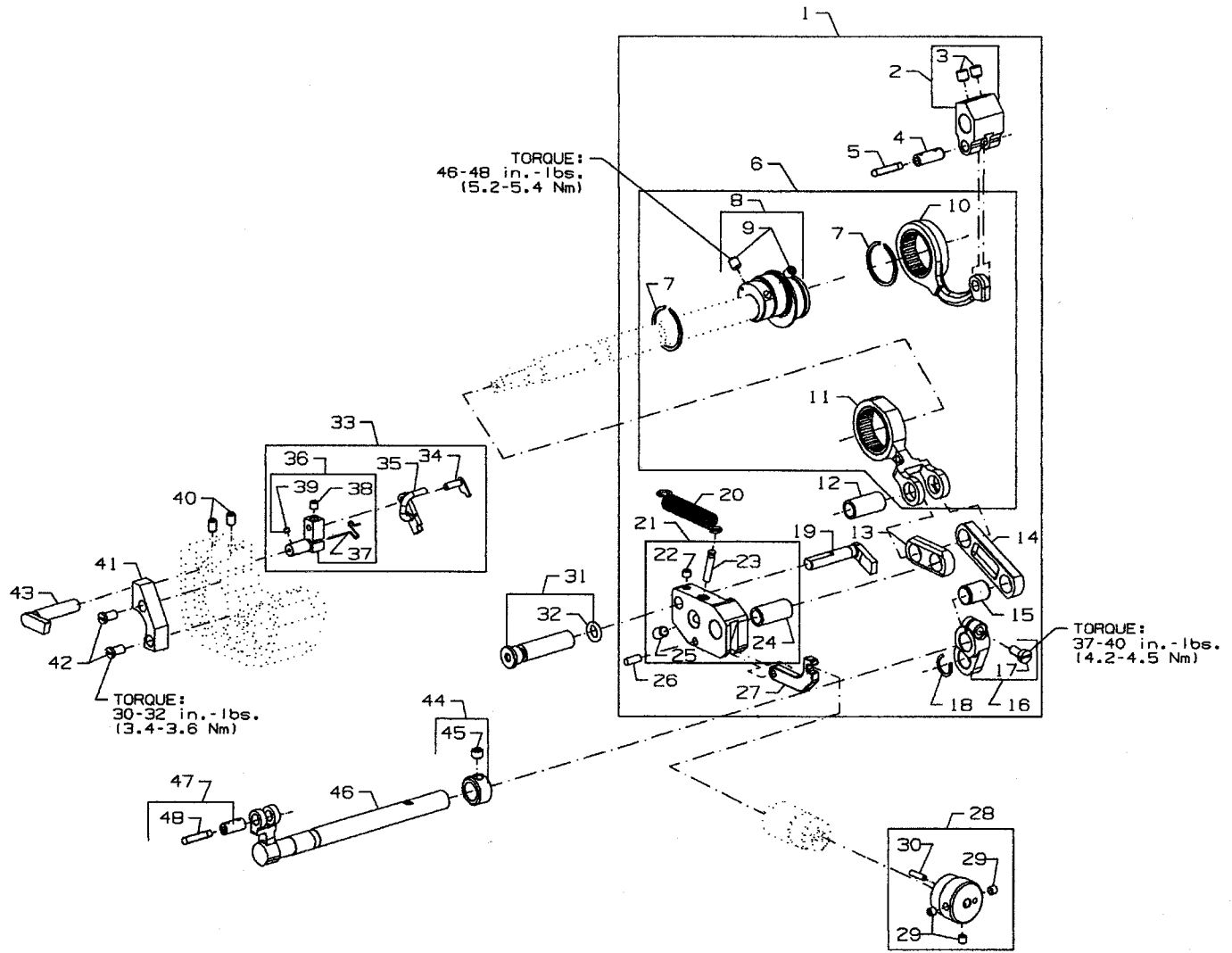

FEED DRIVE MECHANISM

Ref. No.	Part No.	Description	Amt. Req.
1.	29476XT	Feed Drive Assembly	1
2.	50367S	Feed Lifter Lever	1
3.	SS8660612TP	Set Screw	2
4.	G51054	Link Pin	1
5.	666-149	Felt Wick	1
6.	29476SJ	Feed Bar Subassembly	1
7.	999-215	Snap Ring	2
8.	34306D	Double Eccentric	1
9.	22894AD	Screw	2
10.	34335	Connecting Rod Link, for feed link	1
11.	34335A	Connecting Rod, for differential feed	1
12.	34337	Link Pin	1
13.	34337A	Pitman Rod	1
14.	34337B	Connecting Rod	1
15.	50347T	Link Pin	1
16.	34337CA	Differential Feed Drive Lever	1
17.	SS6121010SP	Screw	1
18.	RC0980615K0	Shim Ring	1
19.	34335D	Guide Stud	1
20.	96719	Spring	1
21.	50383Y	Bracket	1
22.	SS8110422TP	Set Screw	1
23.	96865	Dowel Pin, Grooved	1
24.	34337	Link Pin	1
25.	SS8150822TP	Set Screw	1
26.	PH0400104U0	Hinge Pin	1
27.	50367T	Lever	1
28.	50337AP	Knob	1
29.	SS8110422TP	Set Screw	3
30.	B3215470000	Pin	1
31.	50395T	Stud	1
32.	999-211E	"O" Ring	1
33.	29476TP	Cast-off Plate Release Assembly	1
34.	34363C	Stop	1
35.	34363B	Pawl	1
36.	34363	Pawl Support	1
37.	34363A	Spring	1
38.	22894W	Screw	1
39.	28B	Screw	1
40.	22894BD	Set Screw	2
41.	34335H	Feed Bar Guide	1
42.	22569G	Screw	2
43.	34335D	Guide Stud	1
44.	34335J	Collar	1
45.	22894X	Screw	1
46.	34334A	Feed Drive Shaft	1
47.	34336P	Link Pin	1
48.	666-149	Felt Wick	1



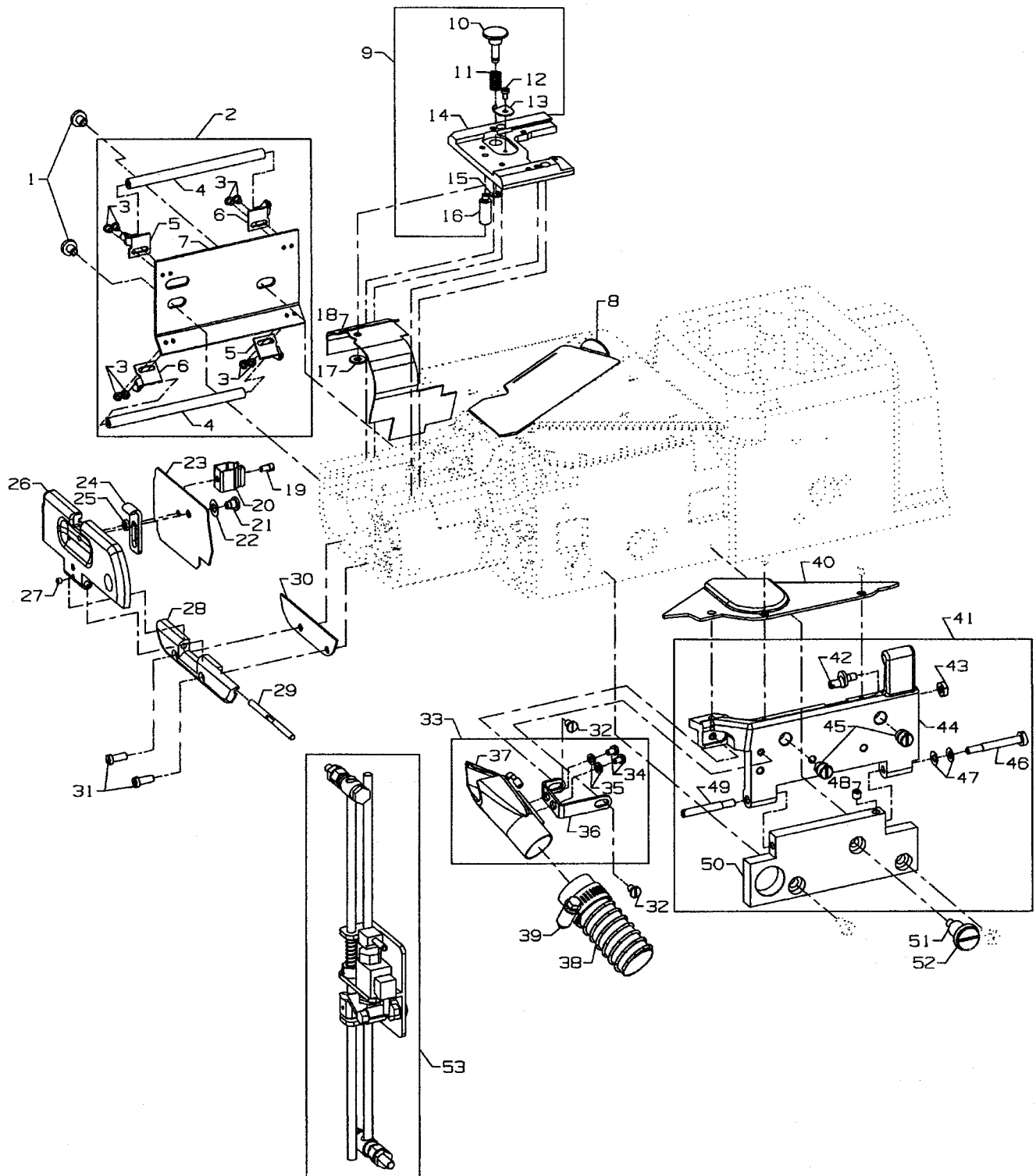

COVERS
FOR
CS122E11, CS132E11, CS125E61, CS125E62,
CS135E61, CS135E62

Ref. No.	Part No.	Description	Amt. Req.
1.	25S	Screw	2
2.	50389	Guide Roller Assembly	1
3.	22561	Screw	8
4.	34786D	Guide Roller	2
5.	34786C	Bracket, right	2
6.	34786B	Bracket, left	2
7.	50389A	Mounting Bracket	1
8.	50302	Slide Cover	1
9.	29476UN	Throat Plate Support Assembly	1
10.	34367	Rest Bolt	1
11.	97014	Spring	1
12.	95685	Screw	1
13.	34367B	Safety Latch	1
14.	34780	Throat Plate Support	1
15.	96277	"E" Ring	1
16.	99364L	Shank Screw	1
17.	69H	Washer	1
18.	50396G	Splash Guard	1
19.	22562B	Screw	1
20.	99697J	Latch Spring	1
21.	22746	Screw, for handle	1
22.	2165D-0.2	Washer	1
23.	50384F	Gasket	1
24.	34382W	Handle	1
25.	C50063N	Washer	1
26.	50382HU	Cylinder Cover	1
27.	22894AY	Set Screw	1
28.	50382JA	Hinge, for cylinder cover	1
29.	34382V	Pin, for hinge	1
30.	34382UA	Gasket, for hinge	1
31.	22541B	Screw, for hinge	2
32.	376	Screw	2
33.	34778GD	Suction Tube Assembly	1
34.	90	Screw	2
35.	80265	Washer	1
36.	34778GF	Bracket	1
37.	G50-748D	Cover	1
38.	99675QA-400	Spiral Hose	1
39.	671C23	Hose Clamp	1
40.	50301BW	Cloth Plate, front	1
41.	50364X	Swing Out Cloth Plate Support	1
42.	99301A	Screw	1
43.	9937	Nut	1
44.	50364Y	Folder Support	1
45.	99356	Stop Screw	2
46.	99350	Screw	1
47.	97127	Cup Spring	2
48.	95	Screw	1
49.	99351	Screw	1
50.	50364S	Hinge Plate	1
51.	99392	Screw	1
52.	660-212	Oil Ring	1
53.	29480ARN	Treadle Assembly	1



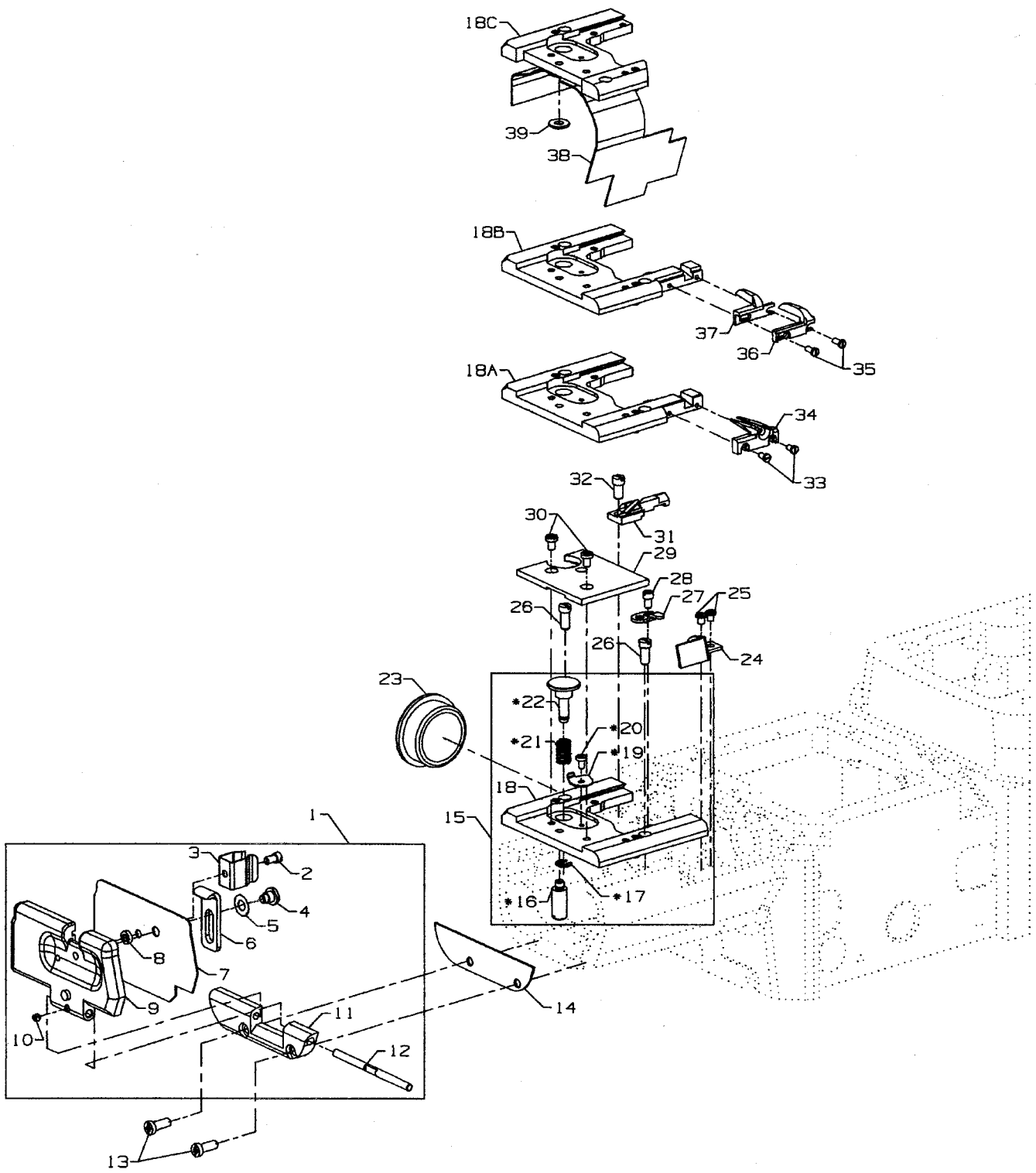

COVERS LOWER BED- FRONT

Ref. No.	Part No.	Description	Amt. Req.
1.	29476TU	Cylinder Cover Assembly	1
2.	22562B	Screw	1
3.	99697J	Latch Spring	1
4.	22746	Screw, for handle	1
5.	2165D-0.2	Spring Washer, for handle	1
6.	34382W	Handle	1
7.	50384F	Gasket	1
8.	C50063N	Washer	1
9.	50382FV	Cylinder Cover	1
10.	22894AY	Screw	1
11.	50382FU	Hinge, for cylinder cover	1
12.	34382V	Pin, for hinge	1
13.	22541B	Screw, for hinge	2
14.	34382UA	Gasket, for hinge	1
*15.	29476TV	Throat Plate Support Assembly, for styles CS122H01, CS132H01, CS125H11, CS125H12, CS135H11, CS135H12	1
*16.	99364L	Shank Screw	1
17.	96277	Retaining Ring	1
18.	34380	Throat Plate Support, for styles CS122H01, CS132H01, CS125H11, CS125H12, CS135H11, CS135H12	1
18A.	34780CA	Throat Plate Support, for styles CS122K01, CS132K01	1
18B.	34780CB	Throat Plate Support, for styles CS122K02, CS132K02	1
18C.	34380T	Throat Plate Support, for styles CS122H21, CS132H21	1
*19.	34367B	Safety Latch	1
*20.	95685	Screw	1
*21.	97014	Spring	1
22.	34367	Stop Bolt	1
23.	50393EU	Plug, for top	1
24.	50382GV	Plate Cover	1
25.	SS6090420SP	Screw, for plate cover	2
26.	J79J	Screw	2
27.	34381A	Support for Slide	1
28.	91	Screw, for support for slide	1
29.	34367A	Cover, for throat plate support	1
30.	90	Screw	2
31.	34381B	Rest for Slide	1
32.	79	Screw, for rest for slide	1
33.	605C	Screw, for material guide, for styles CS122K01, CS132K01	1
34.	34703CA	Material Guide, for styles CS122K01, CS132K01	1
35.	605D	Screw, for material guides, for styles CS122K02, CS132K02	1
36.	34703B	Material Guide, right, for styles CS122K02, CS132K02	1
37.	34703A	Material Guide, left, for styles CS122K02, CS132K02	1
38.	50396G	Splash Guard, for styles CS122H21, CS132H21	1
39.	69H	Washer, for splash guard, for styles CS122H21, CS132H21	1

*NOTE: For the throat plate support numbers 18A., 18B., 18C., asteric items must be ordered seperately to make a complete throat plate support assembly.



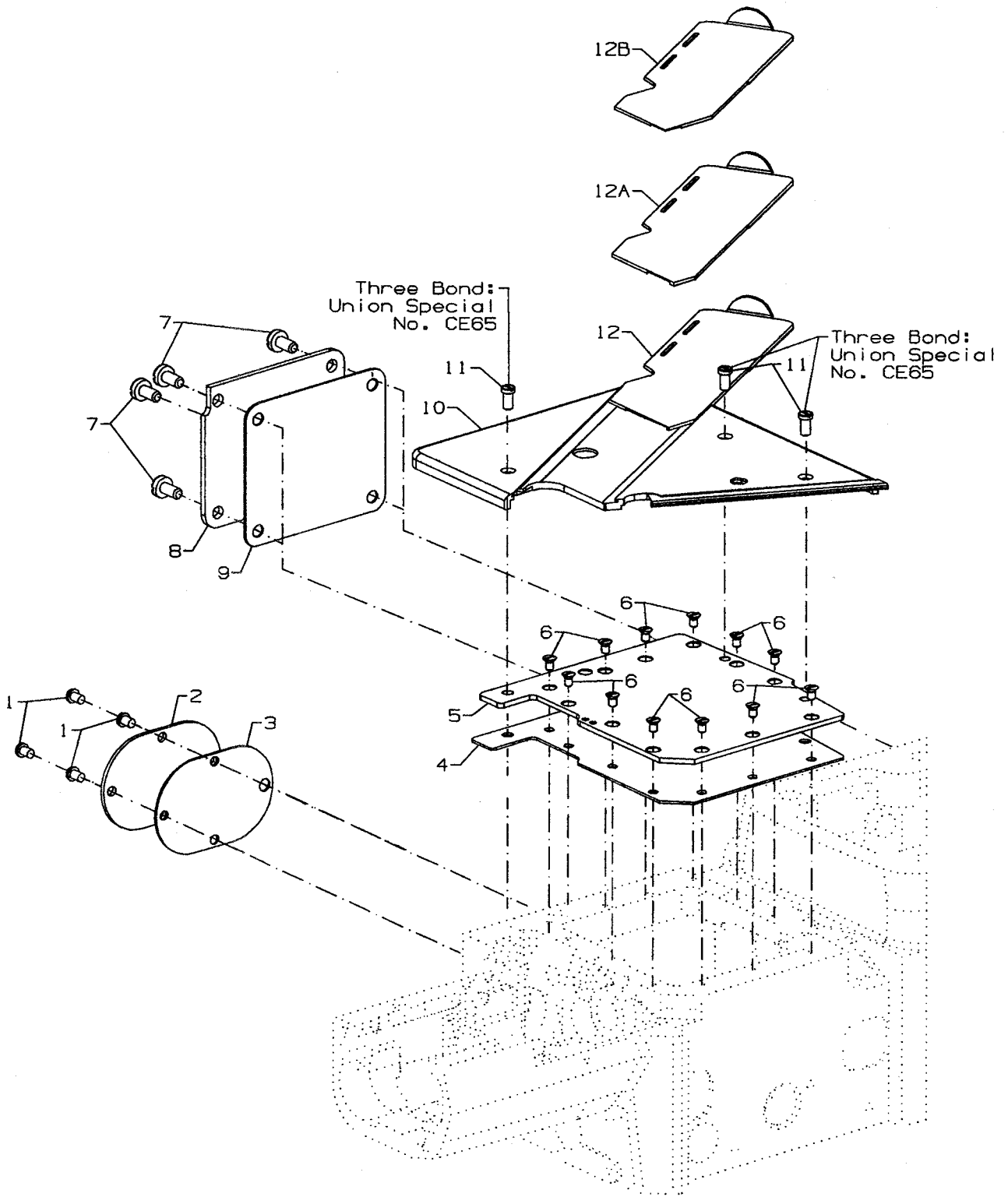

COVERS LOWER BED- MIDDLE

Ref. No.	Part No.	Description	Amt. Req.
1.	SS4120615SP	Screw	4
2.	35082E	Plate	1
3.	35082F	Gasket	1
4.	34382EA	Gasket, for oil reservoir cover	1
5.	34382J	Oil Reservoir Cover	1
6.	87	Screw, for oil reservoir cover	12
7.	22548	Screw, for chamber cover	4
8.	56382D	Chamber Cover	1
9.	34782C	Chamber Cover Gasket	1
10.	50301CP	Cloth Plate Assembly	1
11.	22569AH	Screw, for cloth plate	3
12.	50382HX	Slide Cover, for styles CS122H01, CS122K01 CS122K02, CS132H01, CS132K01, CS132K02	1
12A.	50302D	Slide Cover, for styles CS125H11, CS125H12, CS135H11, CS135H12	1
12B.	50302A	Slide Cover, for styles CS122H21, CS132H21	1



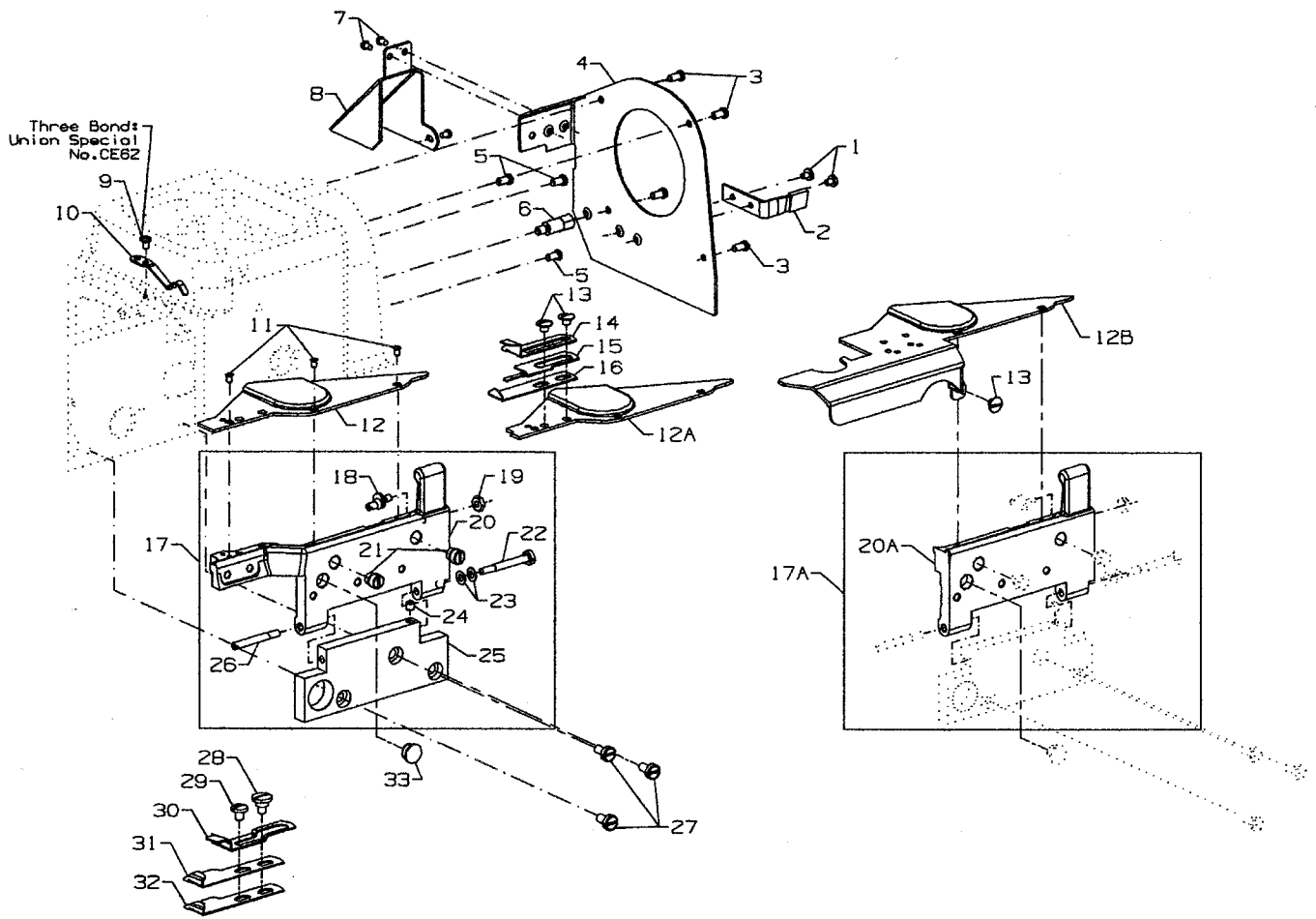

COVERS LOWER BED - REAR

Ref. No.	Part No.	Description	Amt. Req.
1.	22585C	Screw	2
2.	34767K	Synchronizer Stop	1
3.	22569C	Screw	4
4.	50395J	Belt Guard	1
5.	22757E	Screw	3
6.	50395U	Spacer Stud	1
7.	SS4090515SP	Screw	3
8.	50382GR	Belt Guard	1
9.	SM4040655SP	Screw	1
10.	43281K	Latch Spring	1
11.	22766	Screw	3
12.	50301BK	Cloth Plate	1
12A.	50364VB	Cloth Plate, for styles CS125H11, CS125H12, CS135H11, CS135H12	1
12B.	50301BX	Cloth Plate, for styles CS122H21, CS132H21	1
13.	22730	Screw, for cloth plate for styles CS122H21, CS132H21	3
14.	34703ZA	Folder Upper, for styles CS122H21, CS132H21	1
15.	34703Z	Folder, for styles CS122H21, CS132H21	1
16.	34703ZB	Folder L, for styles CS122H21, CS132H21	1
17.	29476SA	Swing-Out Cloth Plate Support, for styles CS122H01, CS132H01, CS125H11, CS125H12, CS135H11, CS135H12, CS122K01, CS122K02, CS132K01, CS132K02	1
17A.	29476TA	Swing-Out Cloth Plate Support, for styles CS122H21, CS132H21	1
18.	99301A	Eccentric Screw	1
19.	9937	Nut	1
20.	50364R	Cloth Plate Support, for styles CS122H01, CS132H01, CS125H11, CS125H12, CS135H11, CS135H12, CS122K01, CS122K02, CS132K01, CS132K02	1
20A.	50364Z	Cloth Plate Support, for styles CS122H21, CS132H21	1
21.	99356	Stop Screw	2
22.	99350	Shoulder Screw	1
23.	97127	Spring Washer	2
24.	95	Set Screw	1
25.	50364S	Hinge Plate	1
26.	99351	Screw	1
27.	22548	Screw	3
28.	22715A	Screw, for CS122H01, CS132H01	1
29.	25S	Screw, for CS122H01, CS132H01	1
30.	34703F3	Hemmer, upper, for styles CS122H01, CS132H01	1
31.	34703F1	Hemmer, lower, for styles CS122H01, CS132H01	1
32.	34703FA1	Hemmer, lower, for styles CS122H01, CS132H01	1
33.	TA1100604R0	Plug	1



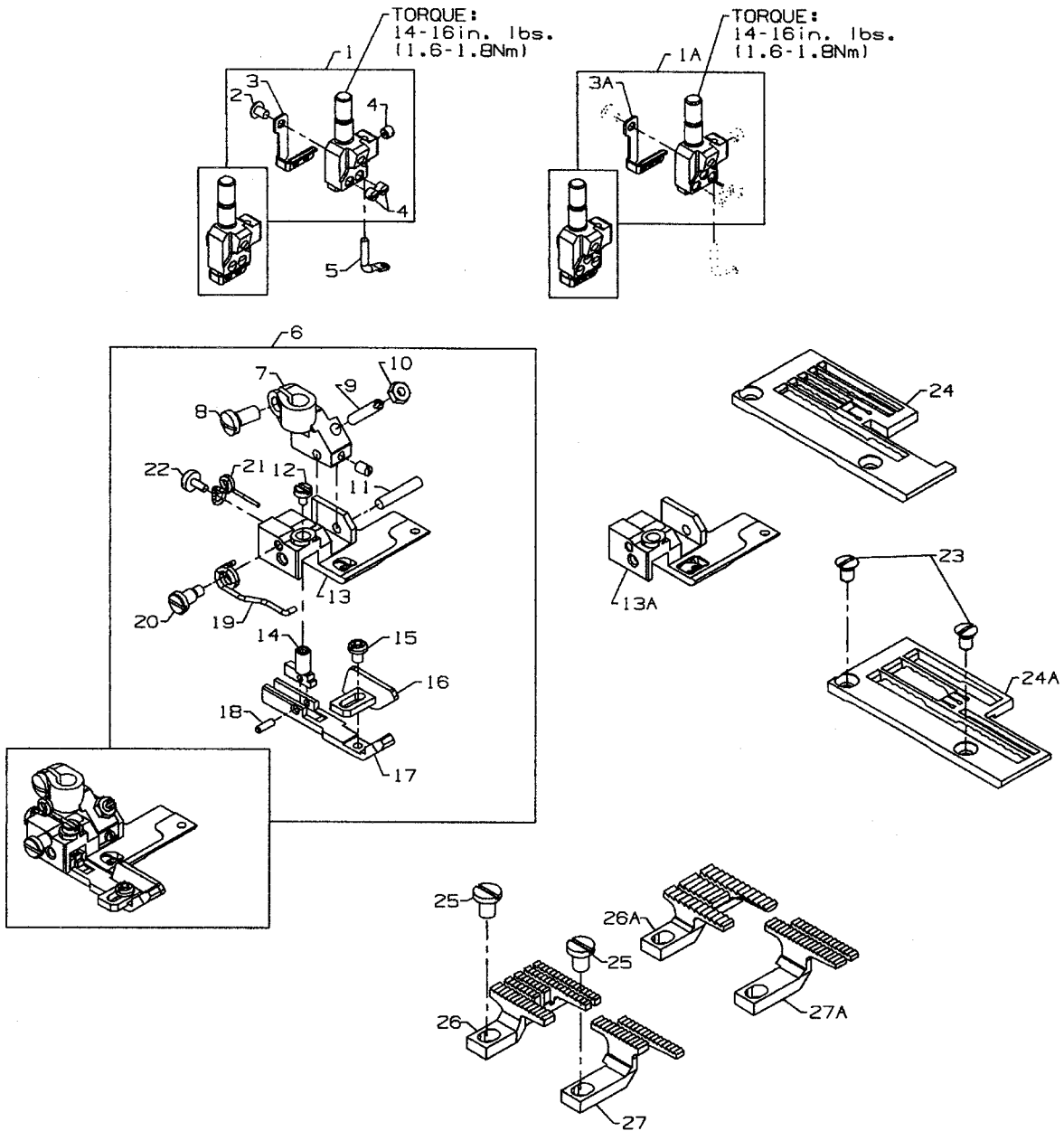

MODEL	NEEDLE HEAD	PRESSER FOOT ASSEMBLY	THROAT PLATE	FEED DOG MAIN	FEED DOG DIFFERENTIAL
CS125E61-2D40	50318AN40	34720TB40	34724TB40	34705BW	34726TB10
CS125E61-2D48	50318AN48	34720TB48	34724TB48		
CS125E61-3D56	50318AN56	34720TB64	34724TB56	34705TB	34726TB16
CS125E61-3D64	50318AN64		34724TB64		
CS135E61-2D40	50318AN40	34720TB40	34724TB40	34705BW	34726TB10
CS135E61-2D48	50318AN48	34720TB48	34724TB48		
CS135E61-3D56	50318AN56	34720TB64	34724TB56	34705TB	34726TB16
CS135E61-3D64	50318AN64		34724TB64		
CS125E62-2D40	50318AN40	34720TB40	34724TB40	34705BW	34726TB10
CS125E62-2D48	50318AN48	34720TB48	34724TB48		
CS125E62-3D56	50318AN56	34720TB64	34724TB56	34705TB	34726TB16
CS125E62-3D64	50318AN64		34724TB64		
CS135E62-2D40	50318AN40	34720TB40	34724TB40	34705BW	34726TB10
CS135E62-2D48	50318AN48	34720TB48	34724TB48		
CS135E62-3D56	50318AN56	34720TB60	34724TB56	34705TB	34726TB16
CS135E62-3D64	50318AN64		34724TB64		



SEWING PARTS
FOR
CS122E11, CS125E61, CS125E62,
CS132E11, CS135E61, CS135E62

Ref. No.	Part No.	Description	Amt. Req.
1.	-----	Needle Head, for sewing comb., on two needle machines (see chart)	1
1A.	-----	Needle Head, for sewing comb., on three needle machines (see chart)	1
2.	SS5060410TP	Screw	1
3.	50318AE40	Eyelet, for sewing comb., on two needle machines (see chart)	1
3A.	50318AE56	Eyelet, for sewing comb., on three needle machines (see chart)	1
4.	SS8080310SP	Screw	3/4
5.	50392G	Needle Thread Eyelet	1
6.	-----	Presser Foot Assembly, for sewing comb., on two needle machines (see chart)	1
6A.	-----	Presser Foot Assembly, for sewing comb., on three needle machines (see chart)	1
7.	50330FP	Shank	1
8.	SM7040800SL	Screw	1
9.	18C1475	Screw	1
10.	NM6030001SD	Nut	1
11.	PH0300164C0	Pin	1
12.	50330FS	Screw	1
13.	50330FM40	Presser Foot Bottom, for sewing comb.; CE11-2D40 (see chart)	1
13A.	50330FM48	Presser Foot Bottom, for sewing comb.; CE11-2D48 (see chart)	1
-	50330FM56	Presser Foot Bottom, for sewing comb.; CE11-3D56, CE11-3D64 (see chart)	1
14.	50330FN	Yielding Section Shank	1
15.	SM4030455SP	Screw	1
16.	50330GN	Elastic Guide	1
17.	50330GR	Yielding Section	1
18.	PH0200063C0	Pin	1
19.	52730Y	Spring	1
20.	18C1479	Shoulder Screw	1
21.	50330FR	Torsion Spring	1
22.	50330FU	Screw	1
23.	87	Screw	2
24.	-----	Throat Plate, for two needle machines (see chart)	1
24A.	-----	Throat Plate, for three needle machines (see chart)	1
25.	99293	Screw	2
26.	-----	Main Feed Dog, for two needle machines (see chart)	1
26A.	-----	Main Feed Dog, for three needle machines (see chart)	1
27.	-----	Differential Feed Dog, for two needle machines (see chart)	1
27A.	-----	Differential Feed Dog, for three needle machines (see chart)	1

MODEL	NEEDLE HEAD	PRESSER FOOT ASSEMBLY	THROAT PLATE	FEED DOG MAIN	FEED DOG DIFFERENTIAL
CS122E11-2D40	50318AN40	34720TB40	34724TB40	34705BW	34726TB10
CS122E11-2D48	50318AN48	34720TB48	34724TB48		
CS122E11-3D56	50318AN56	34720TB64	34724TB56	34705TB	34726TB16
CS122E11-3D64	50318AN64		34724TB64		
CS132E11-2D40	50318AN40	34720TB40	34724TB40	34705BW	34726TB10
CS132E11-2D48	50318AN48	34720TB48	34724TB48		
CS132E11-3D56	50318AN56	34720TB64	34724TB56	34705TB	34726TB16
CS132E11-3D64	50318AN64		34724TB64		



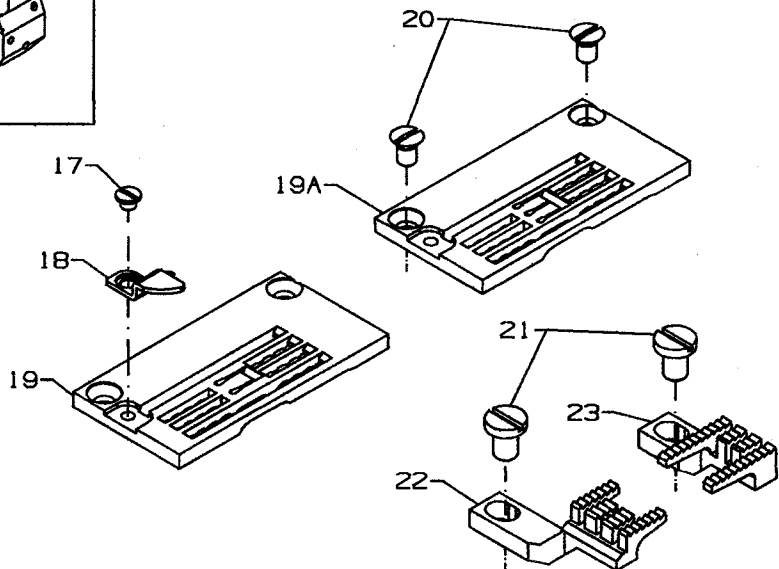
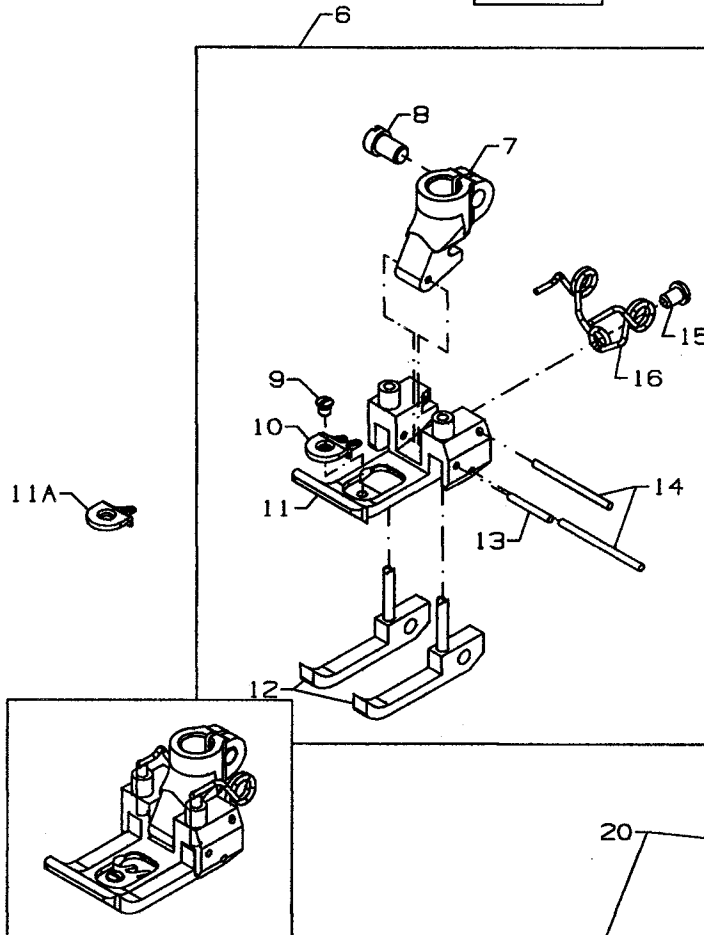
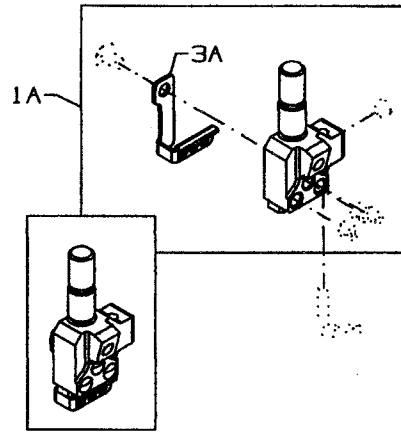
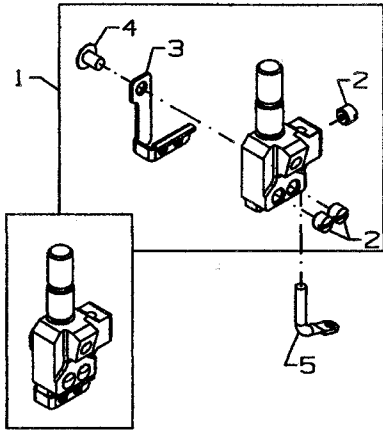

SEWING PARTS
FOR CS122H01, CS132H01

Ref. No.	Part No.	Description	Amt. Req.
1.	-----	Needle Head, on two needle machines, (see chart)	1
1A.	-----	Needle Head, on three needle machines, (see chart)	1
2.	SS5060410SP	Set Screw	3/4
3.	50318AE40	Eyelet, for 4.0, 4.8 gauges (see chart)	1
3A.	50318AE56	Eyelet, for 5.6, 6.4 gauges (see chart)	1
4.	SS6060440TP	Screw	1
5.	50392G	Needle Thread Eyelet	1
6.	-----	Presser Foot Assembly, for sewing comb., (see chart)	1
7.	G65-134	Presser Foot Shank	1
8.	91	Screw	1
9.	G50-266	Bushing	2
10.	22716A	Screw	1
11.	50397A48	Stitch Tongue, for 4.8 gauge	1
11A.	50397C	Stitch Tongue, for 4.0 gauge	1
-	50397A16	Stitch Tongue, for 5.6, 6.4 gauges	1
12.	50330BL16	Presser Foot Bottom	1
13.	57830A	Yielding Section	2
14.	6-25-55	Drill Rod	3
15.	605	Screw	1
16.	79633	Spring	1
17.	HT2C	Screw	1
18.	34703W2.3	Throat Plate Edge Guide	1
-	34703W4.3	Throat Plate Edge Guide	1
19.	-----	Throat Plate, for two needle machines (see chart)	1
19A.	-----	Throat Plate, for three needle machines (see chart)	1
20.	87	Screw, for throat plate	2
21.	99293	Screw, for feed dogs	1
22.	-----	Differential Feed Dog (see chart)	2
23.	-----	Main Feed Dog (see chart)	1

MODEL	NEEDLE HEAD	PRESSER FOOT ASSEMBLY	THROAT PLATE	FEED DOG MAIN	FEED DOG DIFFERENTIAL		
CS122H01-2A40	50318AN40	50320AH	50324BL40	34705F	34726F		
CS122H01-2C40			34724F10				
CS122H01-2A48	50318AN48	50320T48	50328BL48				
CS122H01-2C48			50324F48				
CS122H01-3A56	50318AN56	50320T60	50324BL56				
CS122H01-3B56			50324BS56				
CS122H01-3C56			34724F56				
CS122H01-3A64	50318AN64	50320T60	50324BL64				
CS122H01-3B64			50324BS64				
CS122H01-3C64			34724F64				
CS132H01-2A40	50318AN40	50320AH	50324BL40			34705F	34726F
CS132H01-2C40			34724F10				
CS132H01-2A48	50318AN48	50320T48	50328BL48				
CS132H01-2C48			50324F48				
CS132H01-3A56	50318AN56	50320T60	50324BL56				
CS132H01-3B56			50324BS56				
CS132H01-3C56			34724F56				
CS132H01-3A64	50318AN64	50320T60	50324BL64				
CS132H01-3B64			50324BS64				
CS132H01-3C64			34724F64				



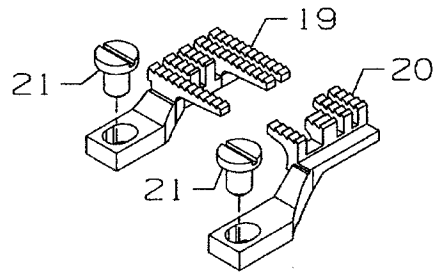
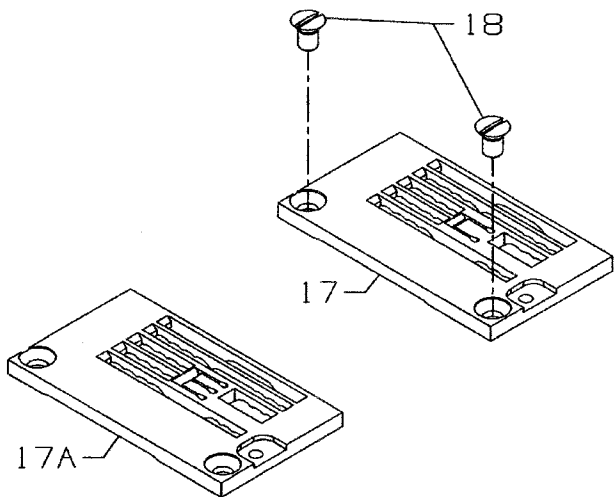
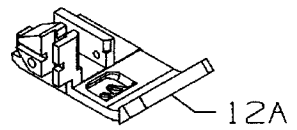
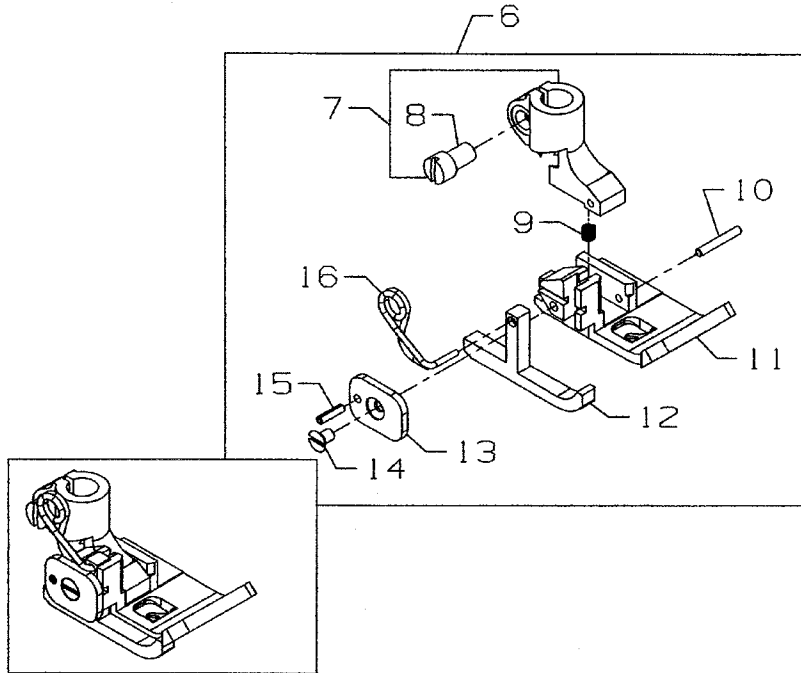
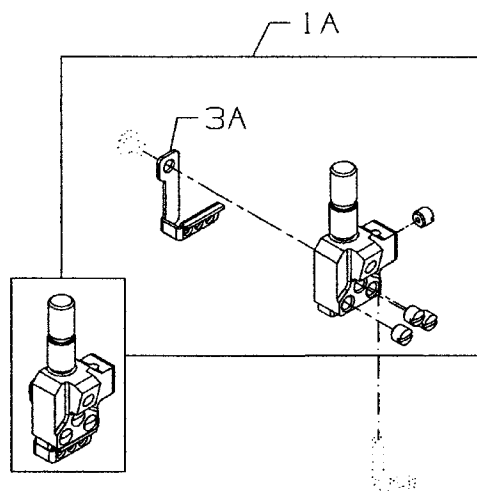
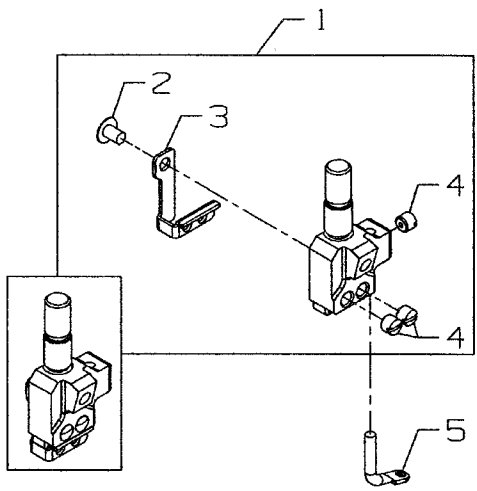

SEWING PARTS
FOR
CS125H11, CS125H12, CS135H11, CS135H12

Ref. No.	Part No.	Description	Amt. Req.
1.	-----	Needle Head, for two needle machines (see chart pages 50-51)	1
1A.	-----	Needle Head, for three needle machines (see chart pages 50-51)	1
2.	SS8080310TP	Screw	1
3.	50318AE40	Needle Eyelet, for 4.0, 4.8 gauges	1
3A.	50318AE56	Needle Eyelet, for 5.6, 6.4 gauges	1
4.	SS5060410SP	Screw	3 / 4
5.	50392G	Needle Thread Eyelet	1
6.	-----	Presser Foot Assembly, for 4.0, 4.8 gauges (see chart pages 50-51)	1
-	-----	Presser Foot Assembly, for 5.6, 6.4 gauges (see chart pages 50-51)	1
7.	G57730GB	Shank	1
8.	91	Screw	1
9.	39568J	Pressure Spring	1
10.	61330B41	Pin	1
11.	50330BH40	Presser Foot Bottom, for 4.0, 4.8 gauges	1
11A.	50330BH64	Presser Foot Bottom, for 5.6, 6.4 gauges	1
12.	34730A	Yielding Section	1
13.	G57730GC	Plate	1
14.	22716	Screw	1
15.	96651	Roll Pin	1
16.	G57730GD	Torsion Spring	1
17.	-----	Throat Plate, for two needle machines (see chart pages 50-51)	1
17A.	-----	Throat Plate, for three needle machines (see chart pages 50-51)	1
18.	87	Screw, for throat plates	2
19.	-----	Main Feed Dog (see chart pages 50-51)	1
20.	-----	Differential Feed Dog (see chart pages 50-51)	1
21.	99293	Screw, for feed dogs	2



SEWING CHART
FOR
CS125H11, CS135H11

MODEL	NEEDLE HEAD	PRESSER FOOT ASSEMBLY	THROAT PLATE	FEED DOG MAIN	FEED DOG DIFFERENTIAL
CS125H11-2A40	50318AN40	50320BE40	50324CJ40	34705DG	34726DG
CS125H11-2C40			34724E10		
CS125H11-2A48	50324CJ48				
CS125H11-2C48	34724E48				
CS125H11-3A56	50318AN56	50320BF64	50324CK56		
CS125H11-3B56			50324CL56		
CS125H11-3C56			34724E56		
CS125H11-3A64	50318AN64		50324CK64		
CS125H11-3B64		50324CL64			
CS125H11-3C64		34724E64			
CS135H11-2A40	50318AN40	50320BE40	50324CJ40		
CS135H11-2C40	50318AN48		34724E10		
CS135H11-2A48			50324CJ48		
CS135H11-2C48	50318AN56	50320BF64	34724E48		
CS135H11-3A56			50324CK56		
CS135H11-3B56			50324CL56		
CS135H11-3C56			34724E56		
CS135H11-3A64	50318AN64	50324CK64			
CS135H11-3B64		50324CL56			
CS135H11-3C64		34724E64			



SEWING CHART
FOR
CS125H12, CS135H12

MODEL	NEEDLE HEAD	PRESSER FOOT ASSEMBLY	THROAT PLATE	FEED DOG MAIN	FEED DOG DIFFERENTIAL
CS125H12-2A40	50318AN40	50320BE40	50324CJ40	34705DG	34726DG
CS125H12-2C40			34724E10		
CS125H12-2A48	50318AN48		50324CJ48		
CS125H12-2C48			34724E48		
CS125H12-3A56	50318AN56	50320BF64	50324CK56		
CS125H12-3B56			50324CL56		
CS125H12-3C56			34724E56		
CS125H12-3A64	50318AN64		50324CK64		
CS125H12-3B64			50324CL64		
CS125H12-3C64			34724E64		
CS135H12-2A40	50318AN40	50320BE40	50324CJ40		
CS135H12-2C40	50318AN48		34724E10		
CS135H12-2A48			50324CJ48		
CS135H12-2C48	34724E48				
CS135H12-3A56	50318AN56	50320BF64	50324CK56		
CS135H12-3B56			50324CL56		
CS135H12-3C56			34724E56		
CS135H12-3A64	50318AN64		50324CK64		
CS135H12-3B64			50324CL56		
CS135H12-3C64			34724E64		



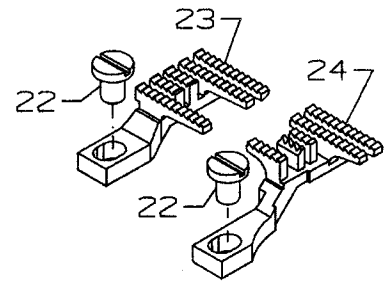
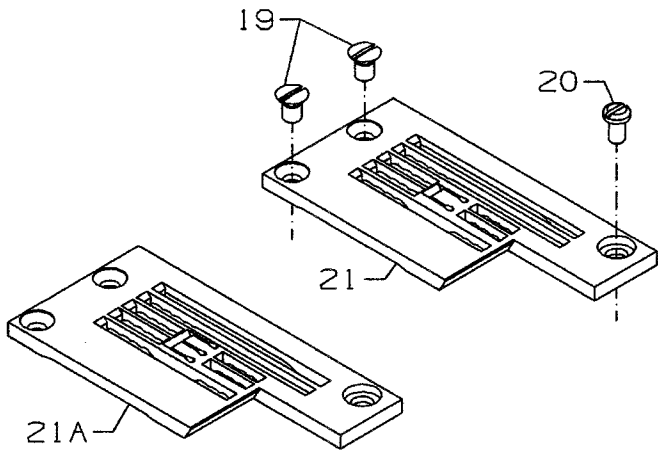
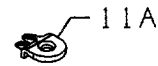
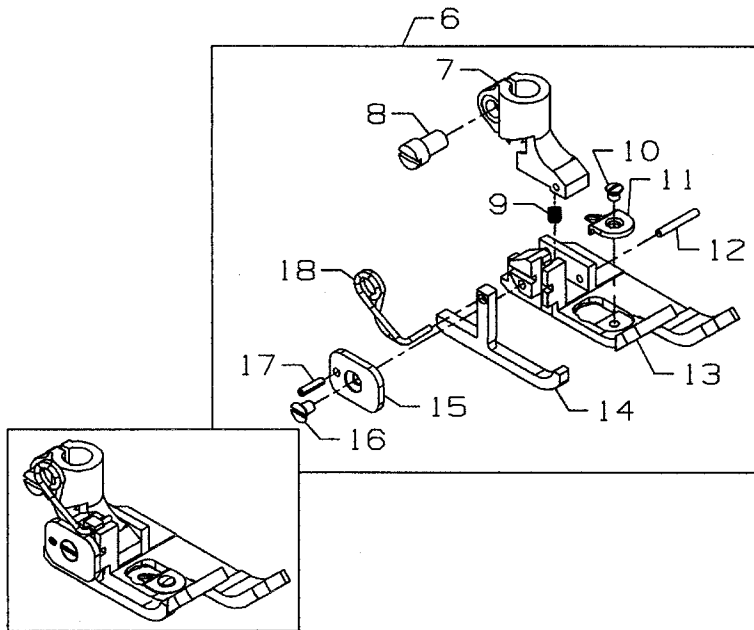
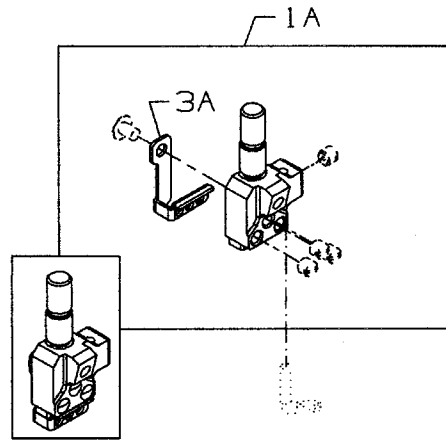
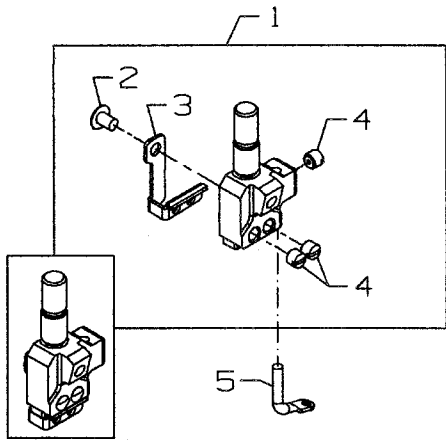

SEWING PARTS
FOR
CS122H21, CS132H21

Ref. No.	Part No.	Description	Amt. Req.
1.	-----	Needle Head, for sewing comb., on two needle machines (see chart)	1
1A.	-----	Needle Head, for sewing comb., on three needle machines (see chart)	1
2.	SS6066440TP	Screw	1
3.	50318AE40	Eyelet, for 4.0, 4.8 gauges	1
3A.	50318AE56	Eyelet, for 5.6, 6.4 gauges	1
4.	SS8080310TP	Screw	3/4
5.	50392G	Needle Thread Eyelet	1
6.	-----	Presser Foot Assembly, for sewing comb. (see chart)	1
7.	G57730GB	Presser Foot Shank	1
8.	91	Screw	1
9.	39568J	Spring	1
10.	22716A	Screw	1
11.	50397C	Stitch Tongue	1
11A.	50397A16	Stitch Tongue	1
12.	61330B42	Drill Rod	1
13.	50330DU64	Presser Foot Bottom	1
14.	34730AT	Yielding Section	1
15.	G57730GC	Plate	1
16.	22716	Screw	1
17.	96651	Roll Pin	1
18.	G57730GD	Spring	1
19.	87	Screw, for throat plate	3
20.	22768	Screw, for throat plate	1
21.	-----	Throat Plate, for two needle machines (see chart)	1
21A.	-----	Throat Plate, for three needle machines (see chart)	1
22.	99293	Screw, for feed dogs	2
23.	-----	Differential Feed Dog (see chart)	1
24.	-----	Main Feed Dog (see chart)	1

MODEL	NEEDLE HEAD	PRESSER FOOT ASSEMBLY	THROAT PLATE	FEED DOG MAIN	FEED DOG DIFFERENTIAL	
CS122H21-2A40	50318AN40	50320GE40	34724FR40	34705FT	34726FT	
CS122H21-2C40			34724FT40			
CS122H21-2A48	50318AN48		34724FR48			
CS122H21-2C48			34724FT48			
CS122H21-3A56	50318AN56	50320BG64	34724FR56			
CS122H21-3B56			34724FS56			
CS122H21-3C56			34724FT56			
CS122H21-3A64			50318AN64			34724FR64
CS122H21-3B64	34724FS64					
CS122H21-3C64	34724FT64					
CS132H21-2A40	50318AN40					50320BG40
CS132H21-2C40			34724FT40			
CS132H21-2A48	50318AN48	34724FR48				
CS132H21-2C48		34724FT48				
CS132H21-3A56	50318AN56	50320BG64	34724FR56			
CS132H21-3B56			34724FS56			
CS132H21-3C56			34724FT56			
CS132H21-3A64			50318AN64	34724FR64		
CS132H21-3B64	34724FS64					
CS132H21-3C64	34724FT64					



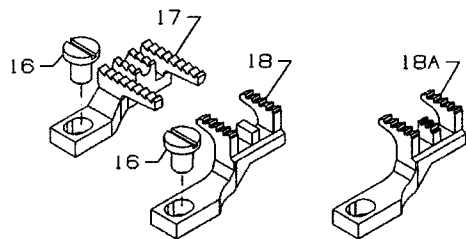
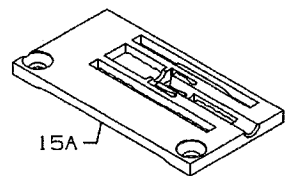
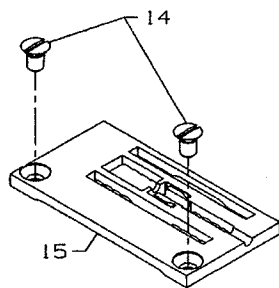
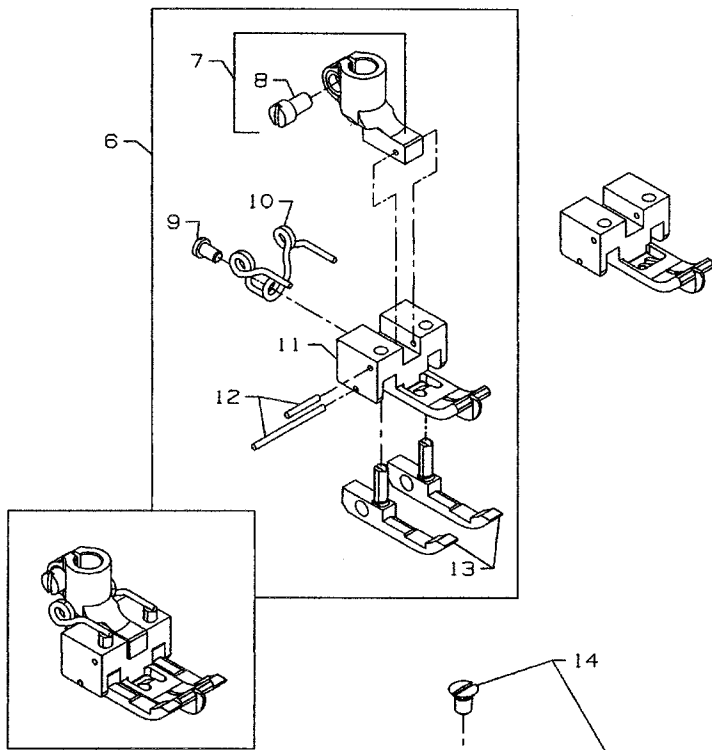
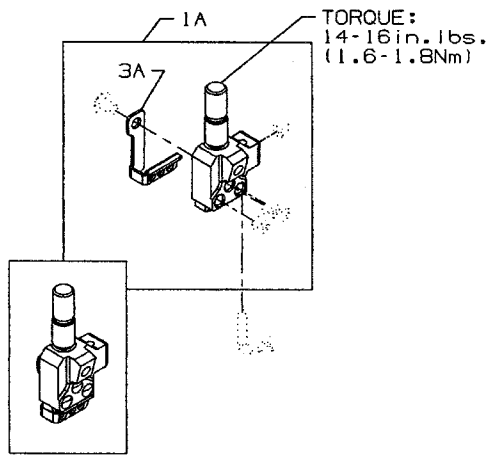
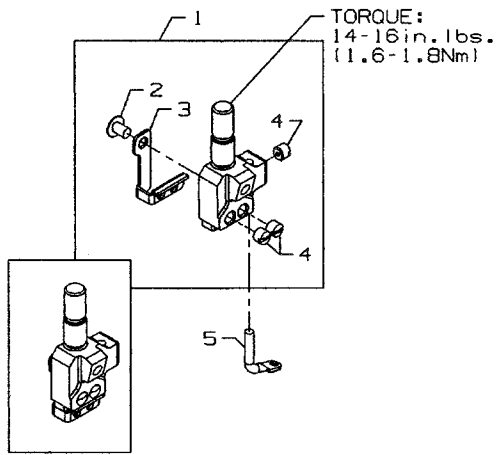

SEWING PARTS
FOR CS122K01, CS122K02
CS132K01, CS132K02

Ref. No.	Part No.	Description	Amt. Req.
1.	-----	Needle Head, for two needle machines (see chart)	1
1A.	-----	Needle Head, for three needle machines (see chart)	1
2.	SS6066440TP	Screw	1
3.	50318AE40	Eyelet, for 4.8 gauge	1
3A.	50318AE56	Eyelet, for 5.6, 6.4 gauges	1
4.	SS8080310TP	Set Screw	4-6
5.	50392G	Needle Thread Eyelet	1
6.	-----	Presser Foot, for sewing comb., (see chart)	1
7.	31130A	Presser Foot Shank	1
8.	91	Screw	1
9.	605C	Screw	1
10.	G11940	Spring	1
11.	G65-90	Presser Foot Guide	1
12.	6-25-55	Drill Rod	2
13.	31130RA	Yielding Section	2
14.	87	Counter Sunk Head Screw, for throat plate	2
15.	-----	Throat Plate, for two needle machines (see chart)	1
15A.	-----	Throat Plate, for three needle machines (see chart)	1
16.	99293	Screw, for feed dogs	1
17.	-----	Main Feed Dog (see chart)	1
18.	-----	Differential Feed Dog, for CS122K01, CS132K01 (see chart)	1
18A.	-----	Differential Feed Dog, for CS122K02, CS132K02 (see chart)	1

MODEL	NEEDLE HEAD	PRESSER FOOT ASSEMBLY	THROAT PLATE	FEED DOG MAIN	FEED DOG DIFFERENTIAL
CS122K01-2D48	50318AN48	34727CA48	34724CA48	34705CA	34726CA16
CS122K01-2D56	50318AN56	34727CA60	34724CA56		
CS122K01-2D64	50318AN64		34724CA64		
CS122K02-2D56	50318AN56		34724CB56		34726A
CS122K02-2D64	50318AN64		34724CB64		34726CA16
CS132K01-2D48	50318AN48	34727CA48	34724CA48		
CS132K01-2D56	58318AN56	34727CA60	34724CA56		
CS132K01-2D64	50318AN64		34724CA64		
CS132K02-2D56	50318AN56		34724CB56		34726A
CS132K02-2D64	50318AN64	34724CB64			



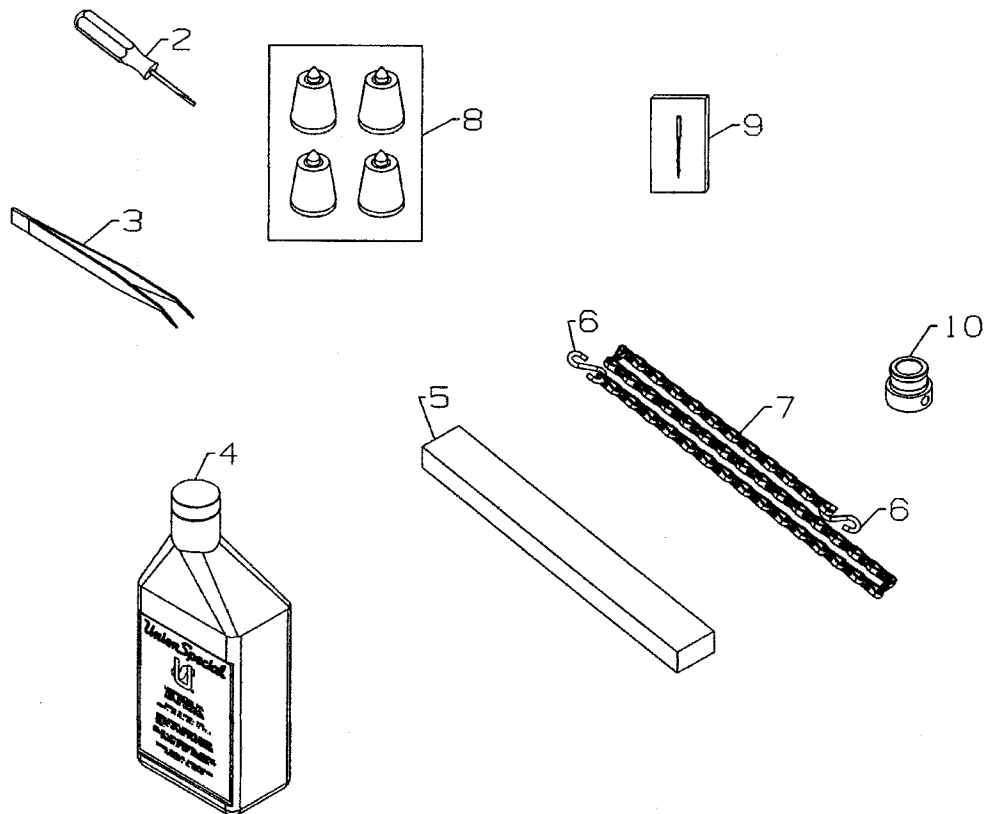
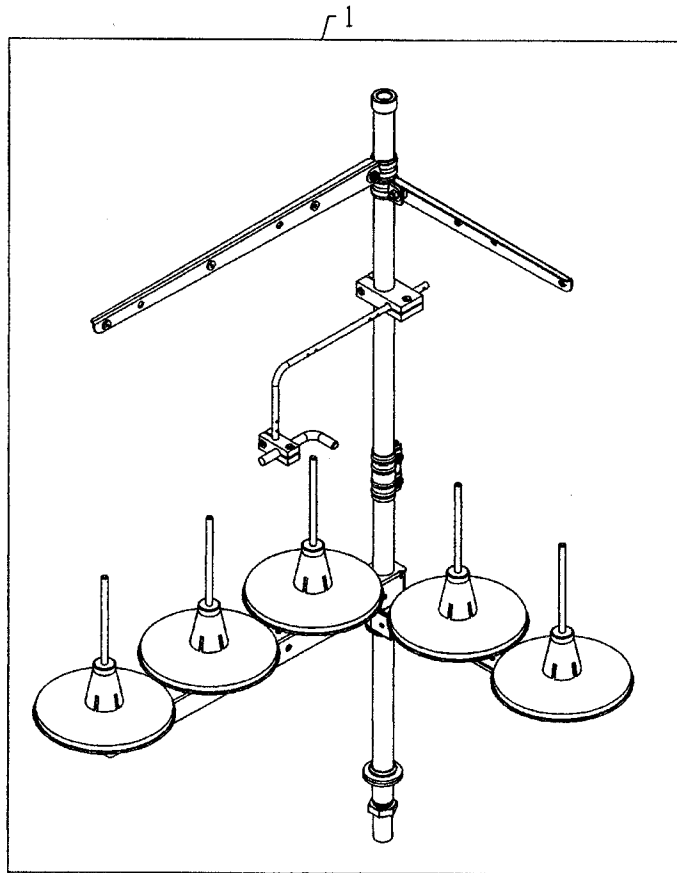

ACCESSORIES

Ref. No.	Part No.	Description	Amt. Req.
1.	11969557	Thread Stand (5 cones)	1
2.	G21201	Screwdriver, for needle head	1
3.	12288403	Thread Tweezer	1
4.	28604R	Oil (1 pint)	1
5.	34395	Profile Rubber	1
6.	660-264	"S" Hook	2
7.	421D42	Chain	1
8.	51295B	Isolator	4
9.	121GJS070/027	Needles	1
10.	34321CC	Flange Synchronizer	1



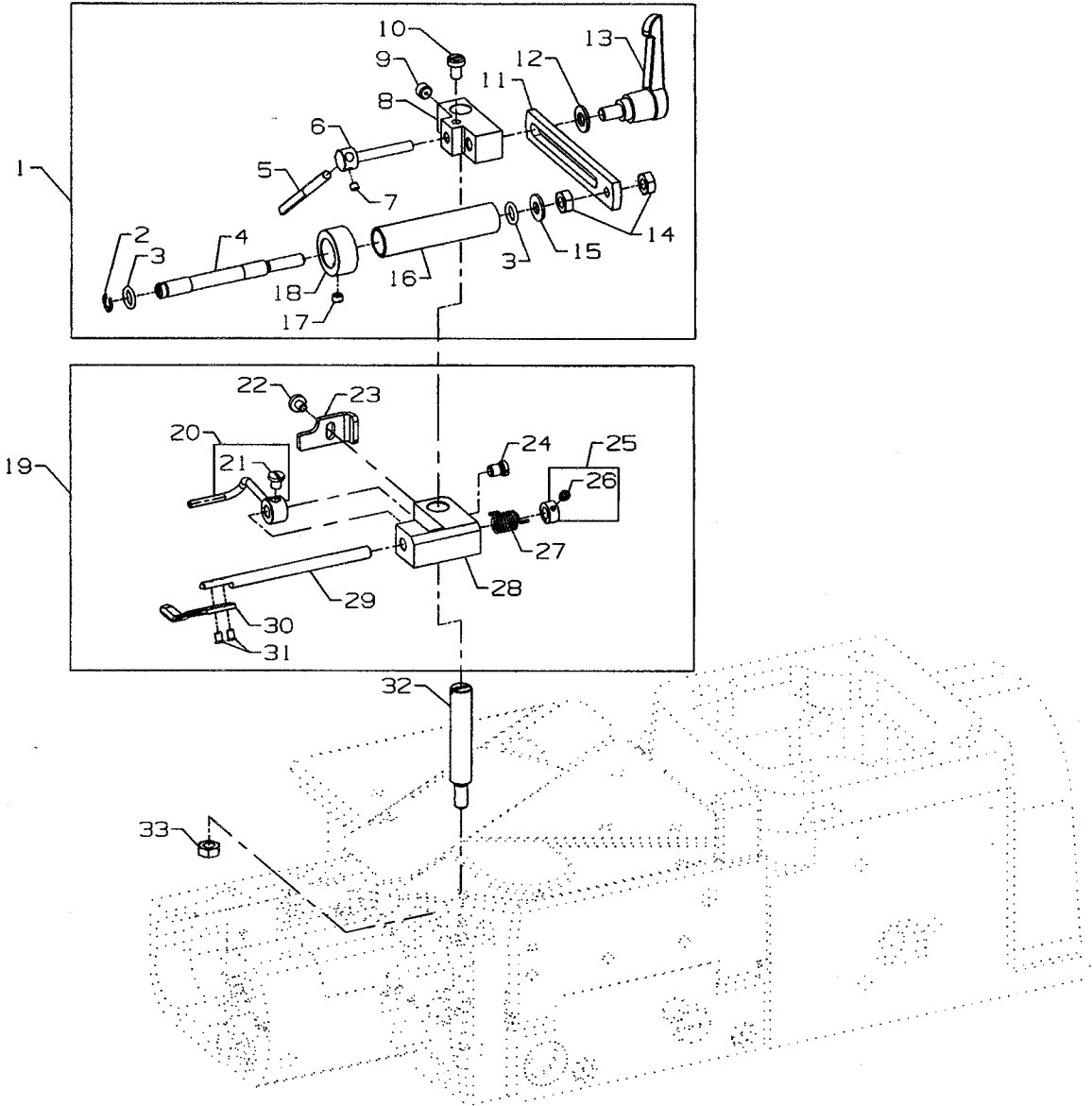

TAPE GUIDE, HOLD DOWN DEVICE
FOR
CS122E11, CS125E61, CS125E62
CS132E11, CS135E61, CS135E62

Ref. No.	Part No.	Description	Amt. Req.
1.	34786G	Tape Guide Assembly	1
2.	96275	Retaining Ring	1
3.	999-30	"O" Ring	2
4.	34786GE	Shaft	1
5.	34786GA	Tape Guide	1
6.	34786GB	Support	1
7.	22894AY	Screw	1
8.	34783N	Support	1
9.	22894X	Screw	1
10.	93A	Screw	1
11.	34786GC	Bracket	1
12.	95951	Washer	1
13.	999-90B	Clamping Lever	1
14.	18	Nut	2
15.	21657E	Washer	1
16.	34786GG	Roller	1
17.	88B	Screw	1
18.	34786GF	Collar	1
19.	34731	Hold Down Device Assembly	1
20.	34731D	Lever	1
21.	22570B	Screw	1
22.	22585C	Screw	1
23.	34731C	Stop	1
24.	22836	Screw	1
25.	39531B	Collar	1
26.	604	Screw	1
27.	97113	Torsion Spring	1
28.	50337BE	Material Hold Down Guide	1
29.	39531A	Shaft	1
30.	34731A	Hold Down Plate	1
31.	77K	Screw	2
32.	99391	Spacer Stud	1
33.	18	Nut	1



Three Bond:
Union Special
No. CE62

Three Bond:
Union Special
No. CE65

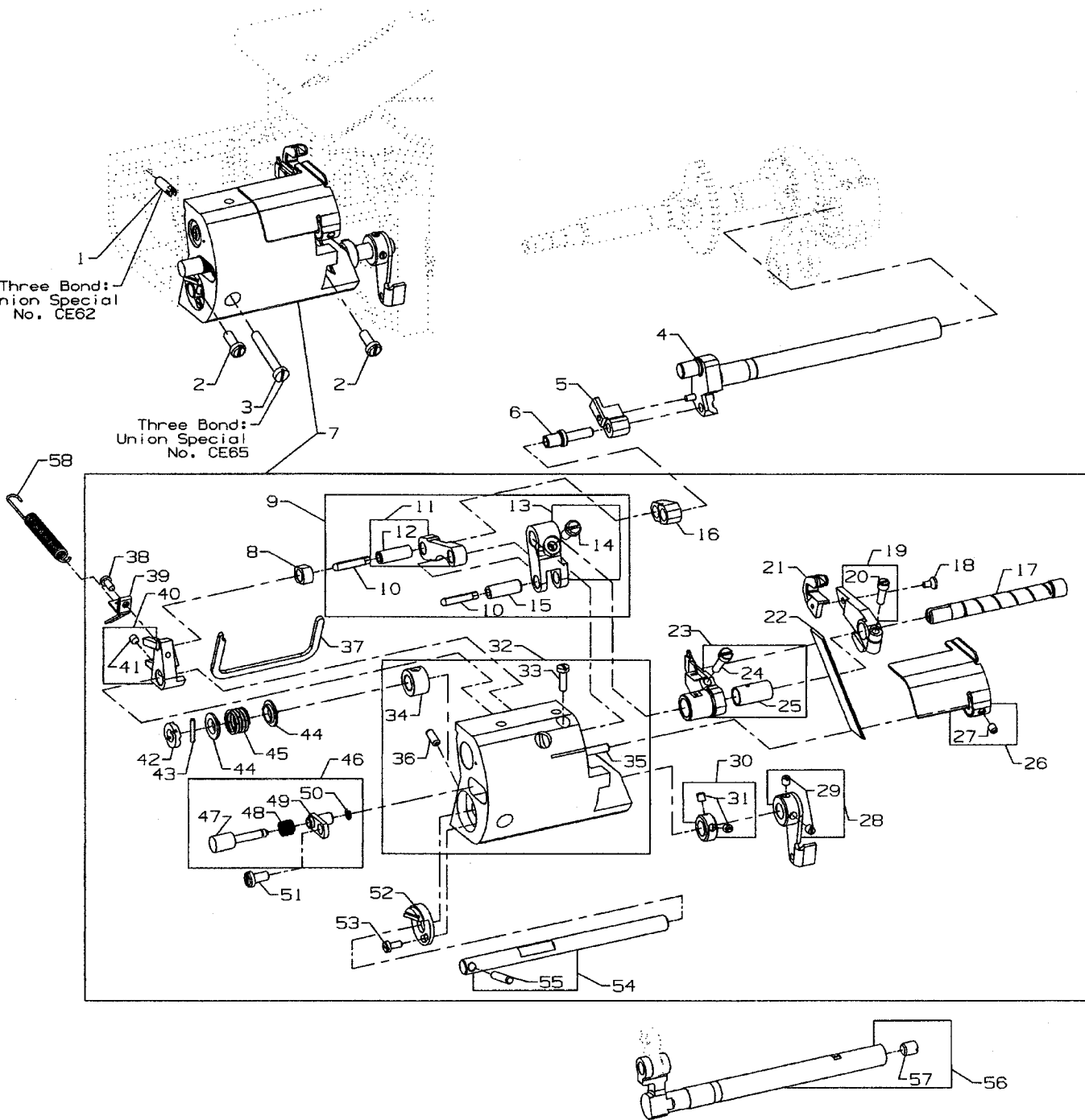

UNDER TRIMMER ASSEMBLY
FOR
CS122E11, CS125E61, CS125E62
CS132E11, CS135E61, CS135E62

Ref. No.	Part No.	Description	Amt. Req.
1.	G51347A	Screw	1
2.	93	Screw	2
3.	22874F	Screw	1
4.	50322BH	Shaft	1
5.	34738A	Spacer	1
6.	99370	Screw	1
7.	29924M	Under Trimmer Assembly	1
8.	34771G	Slide Block	1
9.	34771A	Lever Assembly	1
10.	666-149	Wick	2
11.	34771B	Connecting Rod	1
12.	G51054	Joint Pin	1
13.	34771AA	Lever	1
14.	93	Screw	1
15.	G51054	Joint Pin	1
16.	34771K	Connection	1
17.	34785	Shaft	1
18.	22894BG	Screw	1
19.	34771PA	Upper Knife Lever	1
20.	22729	Screw	1
21.	34770H	Upper Knife	1
22.	34749B	Lower Knife	1
23.	34750EA	Knife Holder	1
24.	22729AB	Screw	1
25.	34750A	Bushing	1
26.	34779	Edge Guide	1
27.	22565C	Screw	1
28.	34771L	Lever	1
29.	88	Screw	2
30.	12865	Collar	1
31.	88	Screw	2
32.	34739N	Housing	1
33.	22585R	Screw	1
34.	34739A	Bushing	1
35.	96529	Pin	1
36.	51280J	Pin	2
37.	1266001	Gasket	1
38.	77L	Screw	1
39.	34771J	Stop	1
40.	34771D	Lever	1
41.	89	Screw	1
42.	99369	Nut	1
43.	96530	Pin	1
44.	34771E	Spring Washer	2
45.	97016	Spring	1
46.	34763B	Locking Plate Assembly	1
47.	34763C	Bolt	1
48.	97015	Spring	1
49.	34763BA	Locking Plate	1
50.	660-210	Retaining Ring	1
51.	22528	Screw	1
52.	34771H	Stop	1
53.	J87J	Screw	1
54.	34771C	Shaft	1
55.	34771F	Pin	1
56.	34734	Shaft, for feed drive	1
57.	CO67B	Cork Plug	2
58.	96722	Spring	1



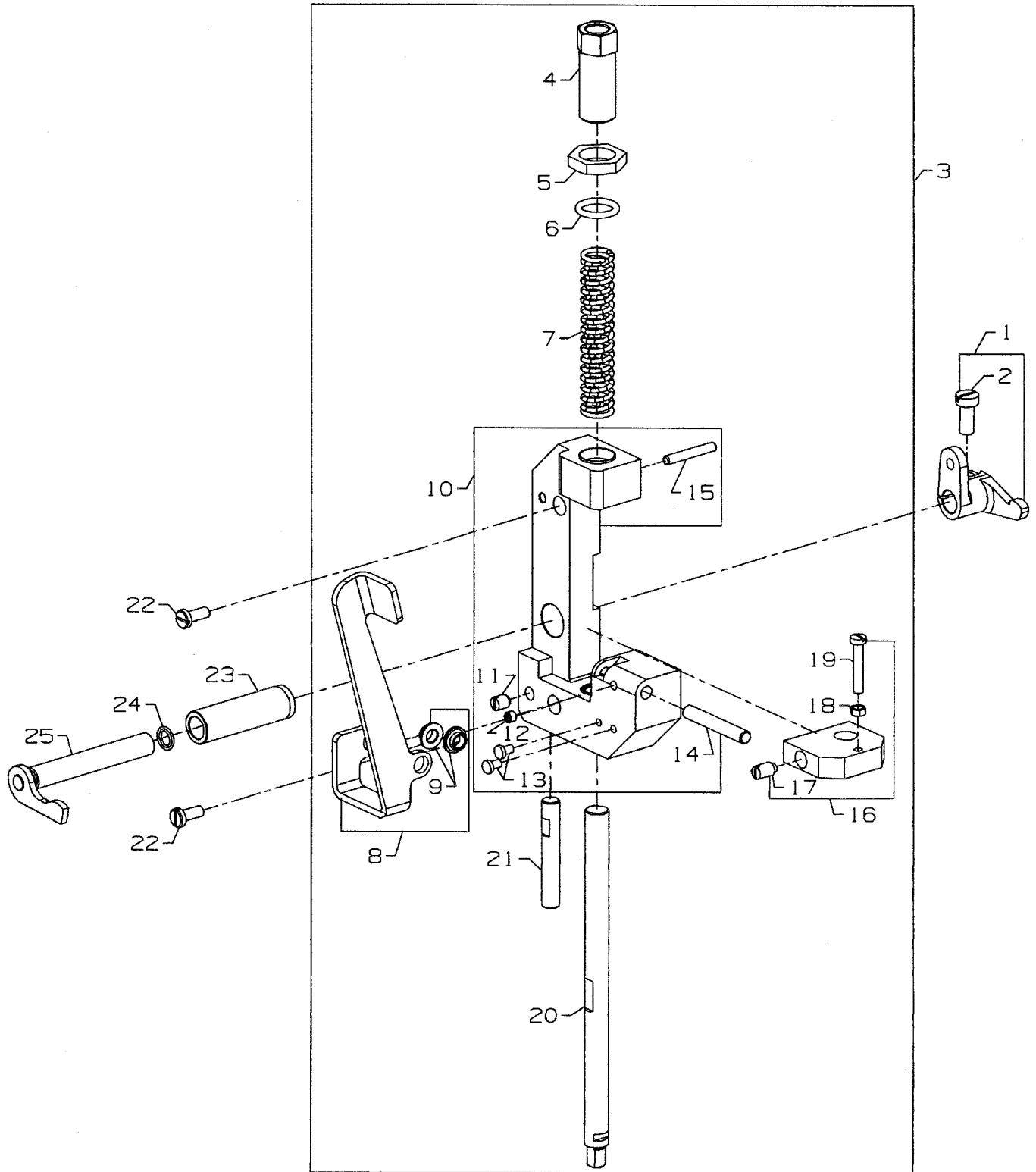

PULLER LIFTER ASSEMBLY
FOR
CS125E61, CS125E62, CS125H11, CS125H12,
CS135E61, CS13562, CS135H11, CS135H12

Ref. No.	Part No.	Description	Amt. Req.
1.	50377VA	Lever, lifter front	1
2.	SS6151440SP	Screw	1
3.	29476UX	Puller Lifter Assembly	1
4.	59477	Regulator	1
5.	35733G	Nut	1
6.	660-212	"O" Ring	1
7.	50377L	Spring	1
8.	50377C	Lever, lifter	1
9.	50344AT	Bushing	2
10.	50377D	Bracket, for roller lifter	1
11.	SS8150710SP	Set Screw	1
12.	SS8120410SP	Set Screw	1
13.	50337AM	Bumper	1
14.	50377AF	Pin	1
15.	96529	Pin	1
16.	50377M	Lifter	1
17.	SS8151150SP	Screw	1
18.	NS6110310SP	Nut	1
19.	SS7112420SP	Screw	1
20.	50377AM	Bar, roller presser	1
21.	50377AR	Guide Pin	1
22.	SS6121220TP	Screw	2
23.	50377T	Bushing, lifter link	1
24.	RO068190100	"O" Ring	1
25.	50377G	Lever, puller lifter	1



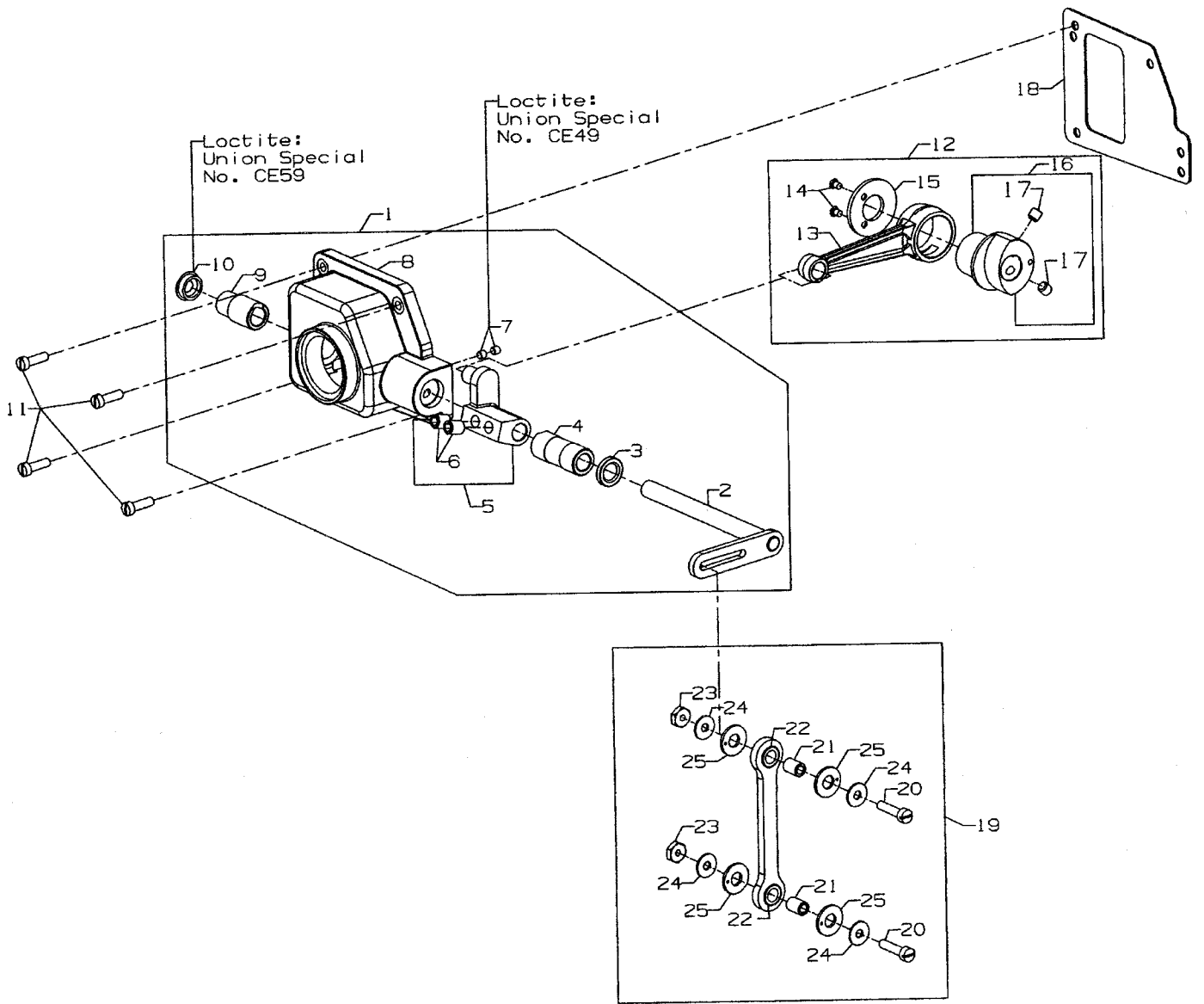

PULLER DRIVE ASSEMBLY
FOR
CS125E61, CS125E62, CS125H11, CS125H12,
CS135E61, CS13562, CS135H11, CS135H12

Ref. No.	Part No.	Description	Amt. Req.
1.	29476SP	Puller Drive Assembly	1
2.	50377F	Roller Driving Arm	1
3.	660-893	Seal	1
4.	50377S	Bushing	1
5.	50377E	Lever, Puller Drive	1
6.	SS8701042TP	Screw	2
7.	SS8110422TP	Set Screw	1
8.	50377U	Housing, Puller Drive	1
9.	50377P	Bushing	1
10.	TA1450404RO	Rubber Plug	1
11.	SS7121610SP	Screw	4
12.	50377Z	Connecting Rod Eccentric Assembly	1
13.	50377AA	Connecting Rod	1
14.	SS2090620SP	Screw	2
15.	50386	Washer	1
16.	50377AB	Eccentric	1
17.	SS8660612TP	Screw	2
18.	50384L	Gasket	1
19.	50377J	Roller Drive Link Assembly	1
20.	SS6122030SP	Screw	2
21.	50344AP	Bushing, link	2
22.	660-303	Bearing	2
23.	NS6120480SP	Nut	2
24.	WP0501046SC	Washer	4
25.	660-1089	Thrust Washer	4



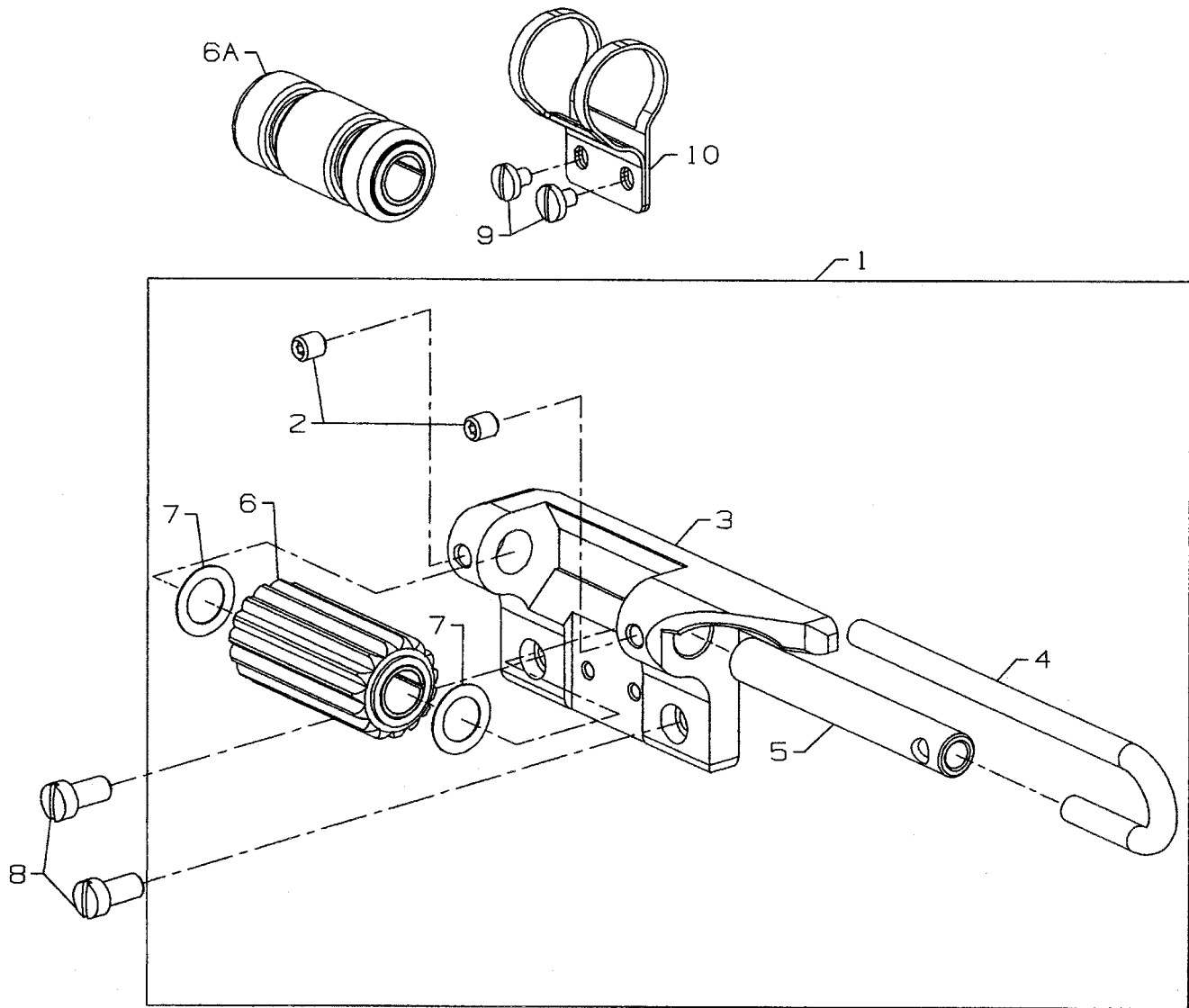

LOWER ROLLER ASSEMBLY
FOR
CS125E61, CS125E62, CS125H11, CS125H12,
CS135E61, CS135E62, CS135H11, CS135H12

Ref. No.	Part No.	Description	Amt. Req.
1.	29476UX	Lower Roller Assembly, for CS125E61, CS125H11, CS135E61, CS135H11	1
-	29476SW	Lower Roller Assembly, for CS125E62, CS125H12, CS135E62, CS135H12	1
2.	22894AD	Set Screw	2
3.	34380B	Bracket (Standard) Cylinder	1
4.	34767	Guard	1
5.	34776B	Shaft	1
6.	50377AT	Lower Roller, for CS125E61, CS125H11, CS135E61, CS135H11	1
6A.	34776F	Lower Roller (Smooth), for CS125E62, CS125H12, CS135E62, CS135H12	1
7.	50386E	Washer, plastic	2
8.	22517	Screw, for lower roller assembly	2
9.	22585C	Screw	2
10.	34380C	Roller Guard	1



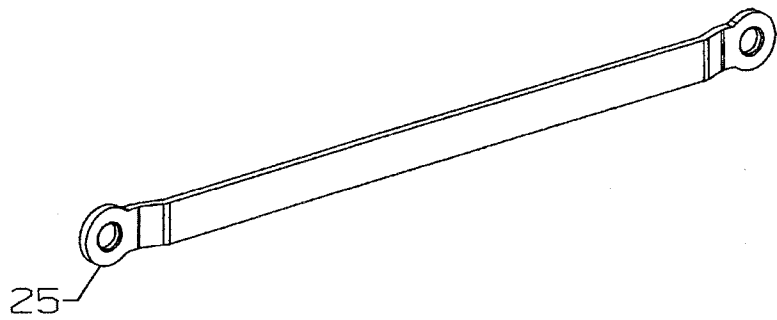
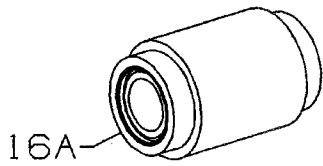
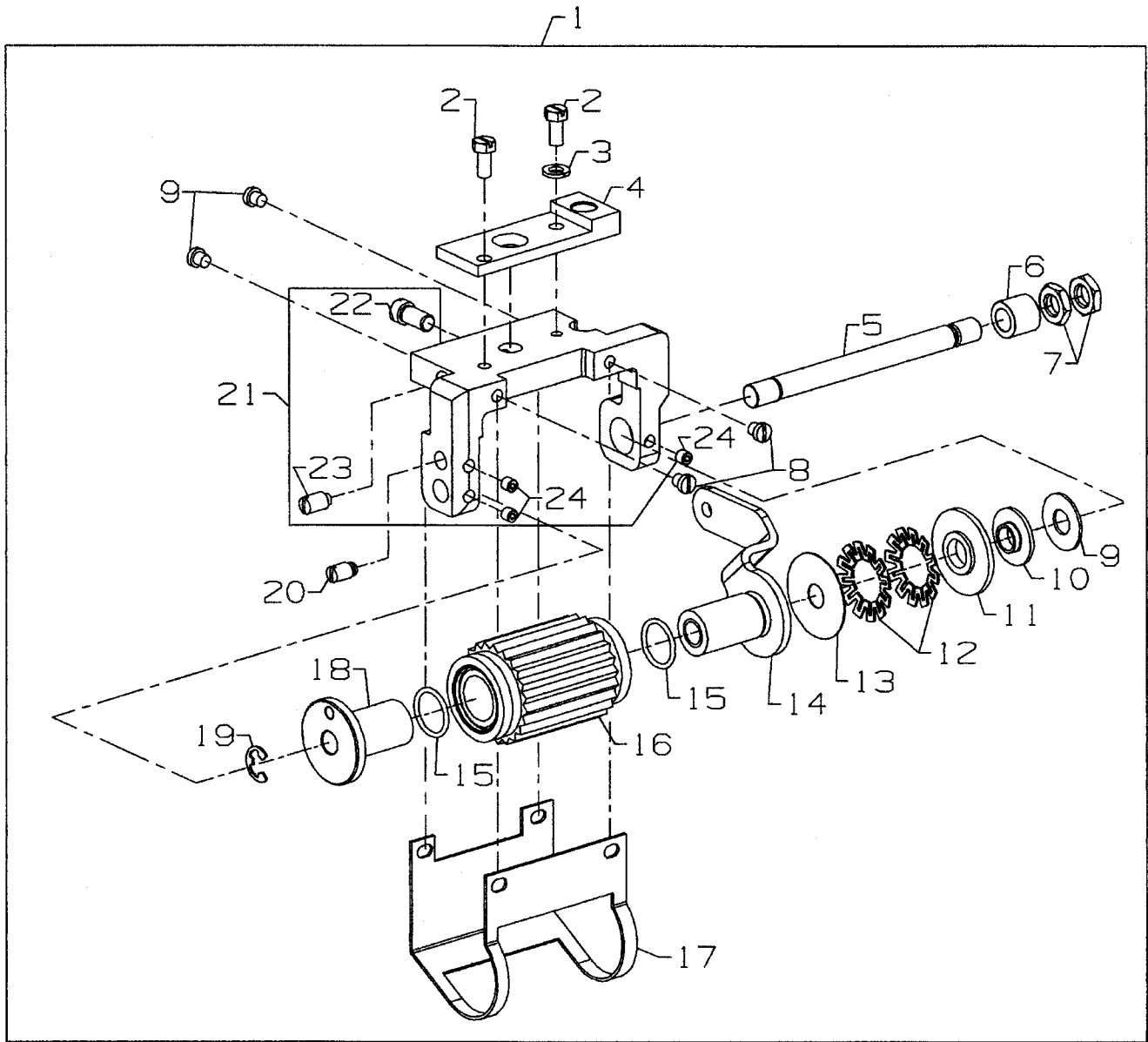

UPPER ROLLER ASSEMBLY
FOR
CS125E61, CS125E62, CS125H11, CS125H12,
CS135E61, CS135E62, CS135H11, CS135H12

Ref. No.	Part No.	Description	Amt. Req.
1.	29476UV	Upper Roller Assembly, for CS125E61, CS125H11, CS135E61, CS135H11.....	1
-	29476SS	Upper Roller Assembly, for CS125E62, CS125H12, CS135E62, CS135H12	1
2.	SS9111010SP	Hex Screw	2
3.	WS0510002KP	Lock Washer	1
4.	50378AD	Guide Plate	1
5.	34774	Shaft	1
6.	34778A	Bushing	1
7.	11638M	Stud Nut	2
8.	SS7110410SP	Screw	4
9.	C50077K	Washer	1
10.	34778C	Bushing	1
11.	50377AE	Disc	1
12.	661-261	Cup Spring	2
13.	50386B	Washer	1
14.	50377H	Lever Assembly	1
15.	661-149	"O" Ring	2
16.	50375Y	Roller Assembly, for CS125E61, CS125H11, CS135E61, CS135H11	1
16A.	50375V	Roller Assembly (Smooth), for CS125E62, CS125H12, CS135E62, CS135H12.....	1
17.	50377AC	Roller Guard	1
18.	50377AD	Bushing	1
19.	96278	"E" Ring	1
20.	22892C	Shoulder Screw	1
21.	50377AK	Feed Roller Yoke Assembly	1
22.	SS6151220SP	Hex Screw	1
23.	SS8151150SP	Screw	1
24.	SS8110422TP	Set Screw	3
25.	50355AS	Wire Connector	1



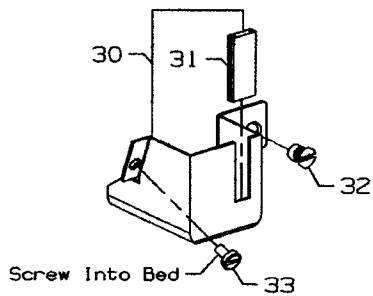
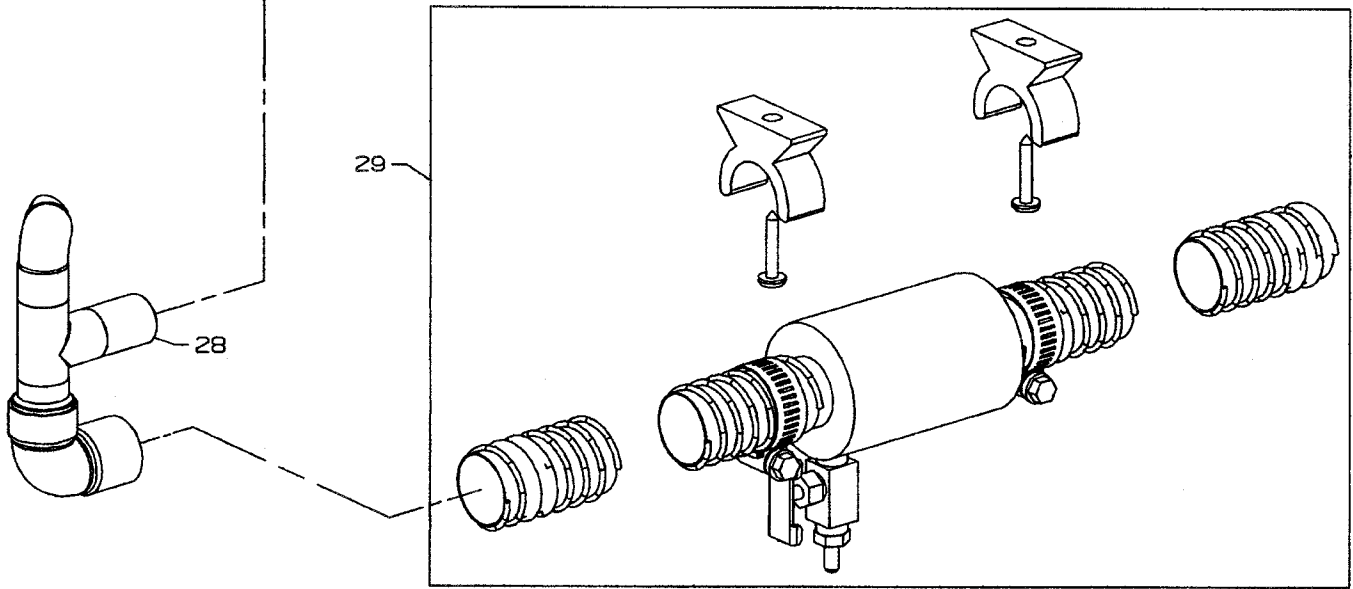
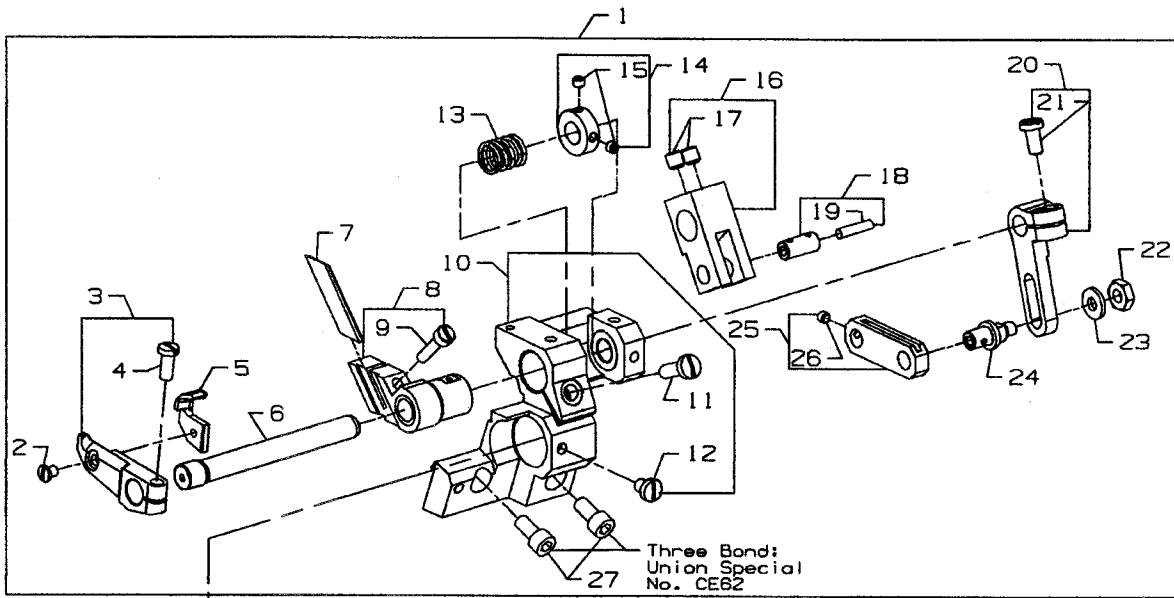

FABRIC TRIMMER ASSEMBLY
FOR CS122H21, CS132H21

Ref. No.	Part No.	Description	Amt. Req.
1.	29924LA	Fabric Trimmer Assembly	1
2.	SS7090530SP	Screw	1
3.	50372A	Knife Lever	1
4.	SS7111120TP	Screw	1
5.	50370J	Upper Knife	1
6.	34785L	Shaft	1
7.	34749EL	Lower Knife	1
8.	50372B	Lower Knife Holder	1
9.	22729ABA	Screw	1
10.	34739L	Support Block	1
11.	22596	Screw	1
12.	25CC	Screw	1
13.	97005D	Spring	1
14.	33688	Adjusting Collar	1
15.	22894AY	Screw	2
16.	34771SL	Lever	1
17.	22894C	Screw	2
18.	34336P	Link Pin	1
19.	666-149	Oil Wick	1
20.	34771VL	Lever	1
21.	22528	Screw	1
22.	9937	Hex Nut	1
23.	4611U	Washer	1
24.	34771UL	Adjusting Bolt	1
25.	34771TL	Connecting Link	1
26.	22894Y	Set Screw	1
27.	95412	Screw	2
28.	671B115	Suction Tube	1
29.	29480AWK	Exhaust Assembly	1
30.	50396L	Guard	1
31.	50382JU	Sliding Cover, For Guard	1
32.	22807	Screw	1
33.	98A	Screw	1



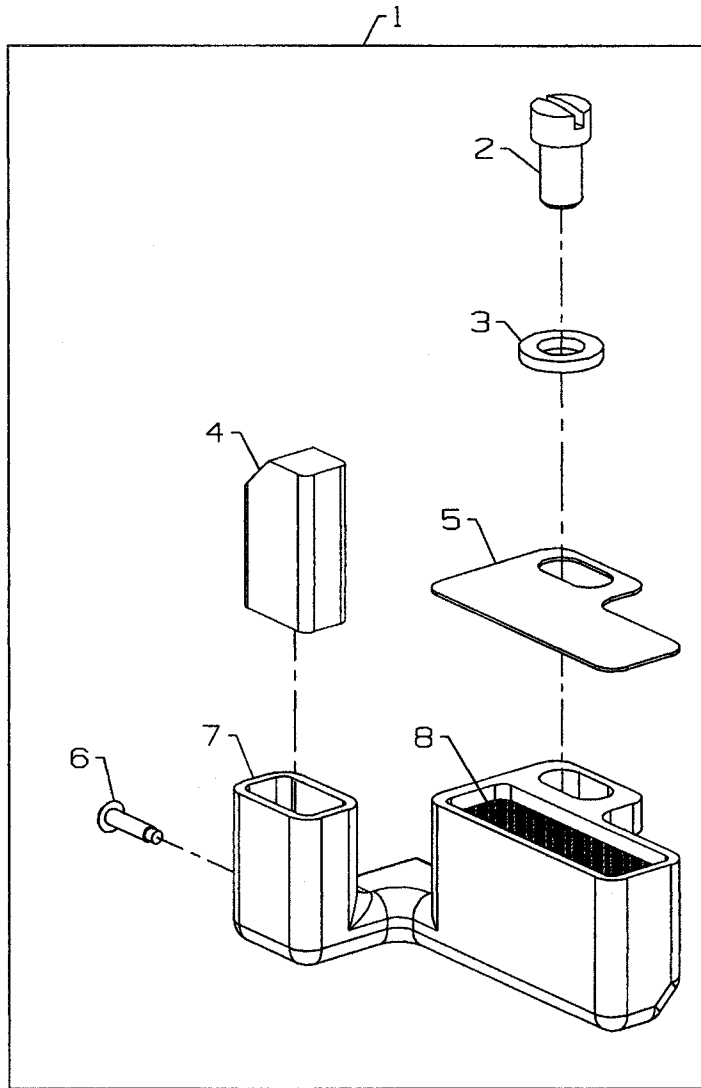

NEEDLE DIPPER (EXTRA SEND CHARGE)

Ref. No.	Part No.	Description	Amt. Req.
1.	29480AZV	Needle Dipper Assembly	1
2.	22562B	Screw, for needle dipper	1
3.	80265	Washer	1
4.	50393GW	Felt	1
5.	50382KD	Needle Dipper Cover	1
6.	666-197	Pin, for oil wick	1
7.	50393KZ	Needle Dipper	1
8.	CQ200000000	Oil Wick	1



NUMERICAL INDEX OF PARTS

<u>Part No.</u>	<u>Page No.</u>	<u>Part No.</u>	<u>Page No.</u>	<u>Part No.</u>	<u>Page No.</u>	<u>Part No.</u>	<u>Page No.</u>
11071602	21	22836	59	31130RA	55	34381A	39
11071701	21	22874C	33	33688	71	34381B	39
11550209	19	22874F	61	34306D	35	34382EA	41
11638M	69	22875N	19	34321CC	25, 57	34382H	33
11969557	57	22892C	69	34334A	35	34382J	41
12124202	17	22894AD	9, 31	34334S	33	34382UA	37, 39
121GJS070/027	57	22894AD	35, 67	34335	35	34382V	37, 39
12288403	57	22894AY	37, 39	34335A	35	34382W	37, 39
1266001	61	22894AY	59, 71	34335D	35	34390	9
12865	61	22894BD	9, 35	34335G	33	34393D	27
18	59	22894BG	61	34335H	35	34393L	27
18-1470	27	22894C	29, 71	34335J	33, 35	34393M	27
18C1471	17	22894T	31	34336A	33	34394A	9
18C1475	45	22894W	29, 35	34336B	9	34394B	9
18C1479	45	22894X	29, 33	34336C	9	34395	57
21657E	59	22894X	35, 59	34336D	9	34642A	29
2165D-0.2	37, 39	22894Y	71	34336E	9	34682C	27
22503F	33	258A	27	34336N	33	34703A	39
22517	67	25CC	71	34336P	35, 71	34703B	39
22528	61, 71	25S	37, 43	34336Q	33	34703CA	39
22541B	29, 37	28604R	57	34336RA	33	34703F1	43
22541B	39	28B	35	34336S	33	34703F3	43
22548	41, 43	29105BK	29	34336U	33	34703FA1	43
22561	37	29126FW	15	34336V	33	34703W2.3	47
22562	21	29475CG	17	34337	35	34703W4.3	47
22562A	33	29476SA	43	34337A	35	34703Z	43
22562B	37, 39	29476SH	33	34337B	35	34703ZA	43
22562B	73	29476SJ	35	34337CA	35	34703ZB	43
22565C	9, 61	29476SP	65	34337F	33	34709D	29
22569AH	41	29476SS	69	34338	33	34730A	49
22569B	25	29476SW	67	34338B	33	34730AT	53
22569C	43	29476TA	43	34340A	33	34731	59
22569G	35	29476TC	11	34342F	9	34731A	59
22570B	59	29476TH	11	34342G	9	34731C	59
22571E	27	29476TJ	27	34342J	29	34731D	59
22571F	9	29476TK	21	34343C	29	34734	61
22580	31	29476TP	35	34344A	29	34738A	61
22585C	43, 59	29476TR	27	34344D	29	34739A	61
22585C	67	29476TS	27	34344E	29	34739L	71
22585R	61	29476TT	21	34353	33	34739N	61
22652A12	29	29476TU	39	34353A	33	34749B	61
22715A	43	29476TV	39	34358BA	31	34749EL	71
22716	49, 53	29476UA	31	34358CA	31	34750A	61
22716A	47, 53	29476UN	37	34358F	17	34750EA	61
22729	61	29476UV	69	34363	35	34763B	61
22729AB	61	29476UX	63	34363A	35	34763BA	61
22729ABA	71	29476VK	29	34363B	35	34763C	61
22730	43	29476VL	27	34363C	35	34767	67
22738B	33	29476XT	35	34366	31	34767K	43
22743	31	29476XU	67	34367	37, 39	34770H	61
22746	37, 39	29480ARN	37	34367A	39	34771A	61
22757E	43	29480AWK	71	34367B	37, 39	34771AA	61
22766	43	29480AYJ	17	34368	31	34771B	61
22768	53	29480AZV	73	34380	39	34771C	61
22807	71	29924LA	71	34380B	67	34771D	61
22811B	29	29924M	61	34380C	67	34771E	61
22829	9	31130A	55	34380T	39	34771F	61



NUMERICAL INDEX OF PARTS

Part No.	Page No.	Part No.	Page No.	Part No.	Page No.	Part No.	Page No.
34771G	61	50304M	31	50337AP	35	50358X	11
34771H	61	50311C	25	50337AW	23	50360	15
34771J	61	50313T	29	50337BE	59	50360B	15
34771K	61	50314G	29	50342AY	13	50360F	15
34771L	61	50317B	11	50342BD	25	50360G	15
34771PA	61	50317C	23	50342BH	25	50360H	15
34771SL	71	50318AE40	45, 47	50343B	29	50363CK	17
34771TL	71	50318AE40	49	50343C	29	50364R	43
34771UL	71	50318AE40	53, 55	50343RC	29	50364S	37, 43
34771VL	71	50318AE56	45, 47	50344AG	29	50364VB	43
34774	69	50318AE56	49	50344AP	65	50364X	37
34776B	67	50318AE56	53, 55	50344AR	25	50364Y	37
34776F	67	50321J	25	50344AT	63	50364Z	43
34778A	69	50321M	13	50344AV	9	50366	17
34778C	69	50322AF	13	50344BK	9	50366A	17
34778GD	37	50322AH	25	50344BL	9	50366B	17
34778GF	37	50322AN	25	50344BM	29	50366G	17
34779	61	50322AZ	9	50344BN	9	50366J	17
34780	37	50322BB	13	50344BP	9	50366L	17
34780CA	39	50322BF	33	50344BU	9	50367S	35
34780CB	39	50322BG	25	50345W	11	50367T	35
34782C	41	50322BH	61	50346	17	50370F	17
34783N	59	50323P	11	50346A	15	50370J	71
34785	61	50323S	31	50347C	15	50372A	71
34785L	71	50325AB	31	50347E	9	50372B	71
34786B	37	50325AL	31	50347F	9	50375V	69
34786C	37	50325AM	31	50347G	15	50375Y	69
34786D	37	50325AN	31	50347J	15	50377AA	65
34786G	59	50330BH40	49	50347L	9	50377AB	65
34786GA	59	50330BH64	49	50347T	35	50377AC	69
34786GB	59	50330BL16	47	50348	29	50377AD	69
34786GC	59	50330CZ	9	50351A	11	50377AE	69
34786GE	59	50330DU64	53	50352	11	50377AF	63
34786GF	59	50330FM40	45	50354F	11	50377AK	69
34786GG	59	50330FM48	45	50354G	11	50377AM	63
34893	29	50330FM56	45	50354H	9	50377AR	63
35082E	41	50330FN	45	50354J	9	50377AT	67
35082F	41	50330FP	45	50355AM	11	50377C	63
35733G	63	50330FR	45	50355AN	11	50377D	63
36271A	17	50330FS	45	50355AR	21	50377E	65
376	37	50330FU	45	50355AS	69	50377F	65
39531A	59	50330GN	45	50357AA	21	50377G	63
39531B	59	50330GR	45	50357AG	31	50377H	69
39536C	33	50332S	27	50357AH	31	50377J	65
39543E	29	50332U	9	50357AJ	31	50377L	63
39568J	49, 53	50332V	21	50357AK	31	50377M	63
41350X	27	50333H	31	50357AR	17	50377P	65
421D42	57	50333P	21	50357AS	17	50377S	65
43281K	43	50335AF	21	50357AT	17	50377T	63
4611U	71	50335AG	21	50357AV	17	50377U	65
50301BK	43	50335AH	21	50357AW	17	50377VA	63
50301BW	37	50335AP	25	50357AX	17	50377Z	65
50301BX	43	50335AW	15	50357V	17	50378AD	69
50301CP	41	50335BC	25	50357Y	17	50381	21
50302	37	50335BD	13	50358U	17	50381B	21
50302A	41	50335BE	29	50358V	17	50381E	9
50302D	41	50337AM	63	50358W	17	50381F	21



NUMERICAL INDEX OF PARTS

Part No.	Page No.	Part No.	Page No.	Part No.	Page No.	Part No.	Page No.
50381G	21	50393FG	27	61330B41	49	96275	59
50382FU	39	50393FH	27	61330B42	53	96276	27
50382FV	39	50393FK	27	61351C	15	96277	37, 39
50382FW	23	50393GB	27	652C16	17	96278	69
50382FX	23	50393GD	27	660-1014	21	96529	61, 63
50382FY	23	50393GF	9	660-1043	13	96530	61
50382FZ	23	50393GT	27	660-1089	65	96651	49, 53
50382GB	23	50393GU	27	660-210	61	96663	33
50382GM	23	50393GW	73	660-212	23, 27	96667	33
50382GR	43	50393HB	23	660-212	37, 63	96719	35
50382GS	27	50393HE	27	660-264	57	96722	61
50382GV	39	50393HH	17	660-283A	19	96841	9
50382HU	37	50393HN	27	660-303	65	96865	35
50382HX	41	50393HS	11	660-739	15, 21	97005D	71
50382JA	37	50393HV	27	660-893	65	97014	37, 39
50382JL	23	50393JP	11	661-149	69	97015	61
50382JN	23	50393JW	11	661-252	29	97016	61
50382JU	71	50393JY	11	661-253	29	97113	59
50382KD	73	50393JZ	11	661-259B	11	97127	37, 43
50383AD	23	50393KV	27	661-261	13, 25	97137	33
50383AE	23	50393KW	9	661-261	69	98A	17, 71
50383Y	35	50393KZ	73	661-262	13	99293	45, 47, 49
50384F	37, 39	50393LA	27	661-348	25	99293	53, 55
50384L	23, 65	50394AF	11	666-149	35, 61	99301A	37, 43
50386	65	50395J	43	666-149	71	99343	29
50386B	69	50395T	35	666-197	73	99346	29
50386E	67	50395U	43	666-329	11	99349	27
50386L	33	50396G	37, 39	666-330	19	99350	37, 43
50386M	33	50396L	71	666-334	23	99351	37, 43
50389	37	50397A16	47	671B115	71	99352	9
50389A	37	50397A16	53	671C23	37	99356	37, 43
50390L	25	50397A48	47	69H	37, 39	99364L	37, 39
50391	13	50397C	47, 53	77A	31	99369	61
50391A	13	50692G	19	77K	59	9937	29, 33, 37
50392AB	9	51235G	29	77L	61	9937	43, 71
50392AU	17	51280J	61	79	39	99370	61
50392AV	19	51295B	57	79633	47	99391	59
50392AW	17	52730Y	45	80265	37, 73	99392	37
50392AX	17	53678N	15	87	41, 45, 47	99652A	29
50392AY	17	56382D	41	87	49, 53, 55	99658	25
50392AZ	17	56390E	25	87U	17	99675QA-400	37
50392BC	19	56390H	29	88	61	99682XC	23
50392G	45, 47	56392G	19	88B	59	99682XCB	23
50392G	49	56392H	19	89	61	99697J	37, 39
50392G	53, 55	56392M	19	90	33, 37, 39	999-211	9
50392S	17	56392R	19	91	39, 47, 49	999-211B	9
50392T	17	57830A	47	91	53, 55	999-211E	35
50392W	19	57844	17	93	33, 61	999-212-035	9
50392X	19	57865	19	93A	59	999-215	35
50392Y	19	57892K	19	95	37, 43	999-254J	27
50392Z	19	59477	63	95205	25	999-30	59
50393EU	23, 39	6-25-55	47, 55	95406	27	999-90B	59
50393EW	23	604	59	95412	71	B3103804000	19
50393EX	27	6042A	31	95685	37, 39	B3112704000	19
50393EZ	9	605	47	95951	59	B3120352000	19
50393FD	27	605A	17	95953	27	B3120704000	19
50393FE	27	605C	39, 55	96162A	25	B3121804000	19
50393FF	27	605D	39	96162B	15	B3126012000	19



NUMERICAL INDEX OF PARTS

<u>Part No.</u>	<u>Page No.</u>	<u>Part No.</u>	<u>Page No.</u>	<u>Part No.</u>	<u>Page No.</u>
B3215470000 ...	35	SS1110640SL ...	23	SS8150822TP ...	35
B3530555000 ...	23	SS1121010SP ...	17	SS8151150SP ...	63, 69
C50044E	17	SS2090620SP ...	65	SS8660512TP ...	15, 29
C50056B	21	SS4080620TP ...	11, 31	SS8660612TP ...	9, 13
C50063N ...	37, 39	SS4090515SP ...	43	SS8660612TP ...	15
C50077K	69	SS4090815SP ...	17	SS8660612TP ...	25, 27
C50094B	27	SS4120615SP ...	17, 23	SS8660612TP ...	35, 65
CE27	11	SS4120615SP ...	41	SS8661012TP ...	13
CE59	11	SS4120915SP ...	17, 19	SS8681412TP ...	13
CE63	11	SS4120915SP ...	23	SS8701042TP ...	65
CE66	21	SS4121215SP ...	23	SS9090640SP ...	15
CO67B	61	SS4121615SP ...	23	SS9111010SP ...	69
CO67D	29	SS5060410SP ...	47, 49	SS9151740CP ...	21
CQ200000000 ...	73	SS5060410TP ...	45	TA1050504RO ...	23
CQ25220000 ...	11	SS6060440TP ...	47	TA1100604RO ...	23, 43
G11940	55	SS6066440TP ...	53, 55	TA1450404RO ...	65
G21201	57	SS6090420SP ...	39	WP0320501SC ...	31
G29105F	29	SS6090440SP ...	11, 31	WP0501046SC ...	65
G29476BV	33	SS6090560TP ...	29	WP0742016SP ...	15
G50-266	47	SS6090620SP ...	11	WS0371026SD ...	17
G50-748D	37	SS6091022TP ...	29	WS0510002KP ...	17, 69
G51054 ...	35, 61	SS6110610TP ...	21	WZ0641510KP ...	23
G51347A	61	SS6121010SP ...	11, 21		
G57730GB ...	49, 53	SS6121010SP ...	35		
G57730GC ...	49, 53	SS6121220TP ...	63		
G57730GD ...	49, 53	SS6122030SP ...	65		
G65-134	47	SS6151220SP ...	69		
G65-90	55	SS6151440SP ...	63		
GA29477AP ...	33	SS6151920SP ...	21		
HA20B	29	SS6153040SP ...	21		
HT2C	47	SS7060310SP ...	17, 31		
J79J	39	SS7080510TP ...	15, 17		
J87J	33, 61	SS7080520SP ...	11, 31		
LA451	23	SS7090520SP ...	19		
NM6030001SD ...	45	SS7090530SP ...	23, 71		
NS6110310SP ...	63	SS7090610SP ...	17		
NS6110420SP ...	19	SS7090910TP ...	17		
NS6120480SP ...	65	SS7110410SP ...	17, 69		
NS6150310SP ...	21	SS7110910TP ...	15		
NS6620320SP ...	23	SS7111120TP ...	11, 13		
NS6680410SP ...	15	SS7111120TP ...	71		
PH0200063CO ...	45	SS7112420SP ...	63		
PH0300164CO ...	45	SS7120640SP ...	17, 23		
PH0400104U0 ...	35	SS7120710SP ...	17, 27		
PS0400142KH ...	9	SS7121410TP ...	15, 19		
RC0980615KO ...	35	SS7121610SP ...	65		
RE0500000KO ...	21	SS7660520SP ...	13		
RE0900000KO ...	31	SS7681410TP ...	13		
RO037180100 ...	9	SS8080310SP ...	45		
RO068190100 ...	21	SS8080310TP ...	49, 53		
RO068190100 ...	63	SS8080310TP ...	55		
SD0380551SL ...	17	SS8080410TP ...	17		
SD0640323TP ...	23	SS8090540SP ...	31		
SD0790303SP ...	21	SS8110422TP ...	11, 15		
SD1000801SH ...	15	SS8110422TP ...	21, 35		
SM4030455SP ...	45	SS8110422TP ...	65, 69		
SM4040655SP ...	43	SS8120410SP ...	63		
SM7040800SL ...	45	SS8150710SP ...	63		





JUKI
Union Special