

Eastman®

**THE EASTMAN®
M9000 Automatic Cutting System**

Model: ETS-M9000

Illustrated Parts List

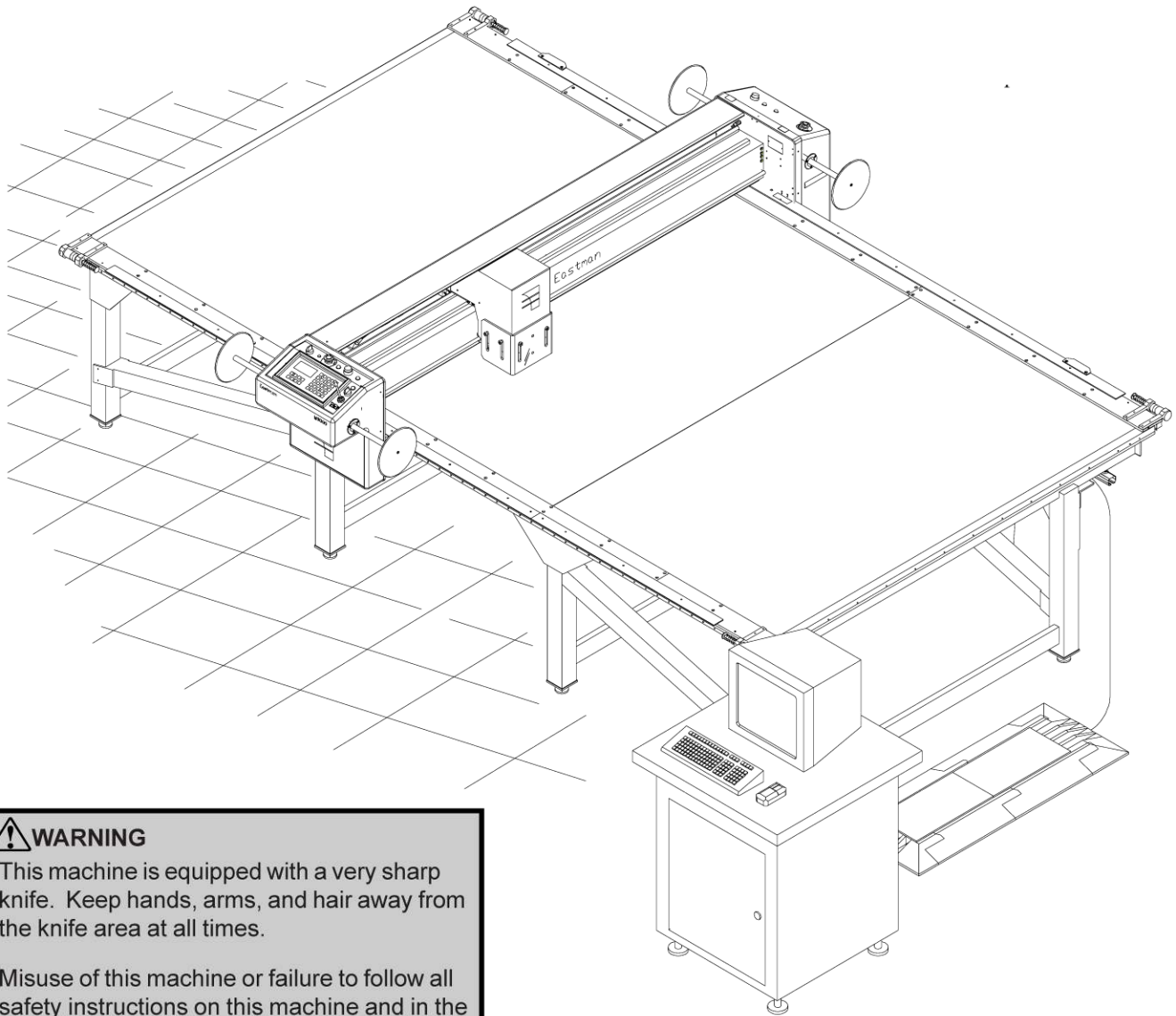

⚠ WARNING

This machine is equipped with a very sharp knife. Keep hands, arms, and hair away from the knife area at all times.

Misuse of this machine or failure to follow all safety instructions on this machine and in the instruction manual may result in serious personal injuries.

Eastman®

Over a Century of Cutting Expertise

Table of Contents

Safety Information	3
Reference Manuals	5
Recommended Spare Parts List	5
Software Solutions	5
M9000 Cutting System Familiarization	6
Computer Control Assembly	7
Festoon Kit & Cable Assembly	8
Gantry Assembly	10
Front Cover Assembly	11
Back Cover Assembly	12
Control Panel Assembly	13
Front End Plate Assembly	14
Back End Plate Assembly	16
Main Tube Assembly	18
Y-Carriage Assembly	20
Tool Head Assembly H9900-3A	22
Rack & Rail Assembly	24
Static Table Assembly	26
Vacuum Components	28
E-Box Assembly 31-B4001	30
Optional: Heavy Duty Tool Head Assembly, 1" H9299-1HD	32
Optional: Fiber Tool Head Assembly H9299-2FC	34
Optional: Static Table Diagnostic Control Cabinet 31-S3285 (110v) 31-S3285-1 (220v/1ph)	36
Bottom Panel Assembly 68-26105-1	37
Rear Panel Assembly, Static 68-26096-1 (110v) 68-26096-4 (220v/1ph)	38
Static Gantry E-Plate Assembly 68-26094	40
Easi Pull Assembly 67-26091-MS	42
Technical Data	44

IMPORTANT

The purchaser must instruct all operators on the proper use of the equipment. All standard industrial safety measures and equipment should be provided to protect the operator. Operators must be cautioned that improper or careless use of this equipment may cause personal injury. If you do not have qualified operators to instruct new persons, contact your Eastman sales representative or Eastman factory direct.

Disconnect electrical power source from before proceeding with any installation, adjustment or repair of the M9000 Automated Cutting System.

Safety Information

Throughout this manual, safety information is presented by the use of the terms **WARNING**, **CAUTION**, and **NOTE**. These terms have the following meanings:

WARNING

A warning contains critical information regarding potential safety hazards that can occur during proper use or misuse of the machine. Failure to follow these procedures may result in serious personal injury to the user.

CAUTION

A caution contains instructions for the use or maintenance of the machine. Failure to follow these procedures may result in damage to the machine.

ELECTRICAL HAZARD

An electrical hazard calls attention to a procedure, practice, or the like, which, if not correctly performed or adhered to, could result in personal injury. Do not proceed beyond an Electrical Hazard.

Supplementary information may be given in a Note.

Safety and Indemnification

During the life of the machine, the purchaser agrees to provide to all machine users (including its own employees and independent contractors) all relevant safety information, including warning labels and instruction manuals. The purchaser also agrees to maintain the safety features and working condition of the machine, and to adequately train all users in the safe use and maintenance of the machine. The purchaser agrees to defend, protect, indemnify, and hold Eastman Machine Company and its subsidiaries harmless from and against all claims, losses, expenses, damages, and liabilities to the extent that they have been caused by the purchaser's failure to comply with the terms and instructions of this manual.

General Safety Precautions

WARNING

This machine is equipped with very sharp and dangerous tools. Keep hands, arms, and hair away from the cutting area and drive system at all times. Safety gloves, glasses, and appropriate clothing may prevent serious personal injuries.

Disconnect all power sources to the machine when it is not in use or during routine maintenance, including cleaning and lubrication.

The purchaser must instruct all operators in the proper use of the machine according to the instructions in this manual. This training must include instruction on the potential safety hazards arising from the use or misuse of the machine. In addition to such training, the purchaser should provide written work instructions as necessary to ensure correct use of the machine for specific cutting applications.

Eastman®

Over a Century of Cutting Expertise

WARNING

The purchaser must provide appropriate safety measures and equipment as recommended in this manual. Observe all statutory requirements concerning the use of hazardous machinery that apply to your location.

Do not modify this machine or disable safety features. Unauthorized modification may result in serious personal injuries to the user. A qualified electrician, familiar with applicable codes and regulations, must make electrical connections to this machine. Misuse of this machine or use of this machine as part of another machine may result in serious personal injuries to the user.

Safety labels must be kept clean and legible at all times. Call the Eastman factory to order replacement labels.

CAUTION

Eastman Technology Systems equipment is not designed for use in conditions of extreme temperature or humidity. Operating this equipment in an environment outside the specified ranges may result in damage and will void the warranty.

Acceptable operating temperature range: 10°C to 35°C (50° to 95°F).
Acceptable operating humidity range: 20% to 80% (non-condensing).

Altitude: We anticipate that the system will operate within all specifications at an altitude up to 1000m above mean sea level.

Transportation: During transportation and storage, the system is capable of withstanding ranges from -25°C to 55°C and for periods not exceeding 24 hrs. at up to +70°C.

Lifting/Moving: The lifting or moving of this system must be in accordance with the installation requirements. Failure to adhere to these installation requirements may cause injury to persons or hinderance or the machine performance.

This system operates at 96dba under full load. Hearing protection devices must be used during prolonged exposure to the noise.

Specifications

	Voltage	Current	Frequency	# of phases
Computer	120vac	6A	50/60 Hz	Single
E-Box, Conveyor	230 vac	30A	50/60 Hz	Three
E-box, Gantry	120vac	10A	50/60 Hz	Single
Internal Blower (5)	230vac	17.4A Each	50/60 Hz	Three
External Blower (1)	230vac	60A	50/60 Hz	Three
Gantry	120vac	1.2A	50/60 Hz	Single
	5/12vdc	3/2A	50/60 Hz	Single

The Eastman **ETS-M9000** Automated Cutting machine has been inspected and tested at the factory prior to shipment. The ETS-M9000 machine is shipped partially disassembled and requires some assembly and setup before operation can take place. Refer to the installation guide for installation instructions. To get the best performance, familiarize yourself and all operators with all functions and adjustments of this equipment. Refer to the M9000 service manual. Before any operation takes place it is important carefully read and follow the instructions in these reference manuals.

This Illustrated Parts List is a comprehensive list of the components used in the machine. When ordering replacement parts, please include machine name and serial number. Some machine configuration may require additional components not shown, please consult factory for part numbers.

The following list of recommended spare parts and reference manuals may be included with your machine or purchased at a later date.

Reference Manuals

- E-509 M9000 Instruction and Service Manual
- E-509-M9000 M9000 Illustrated Parts List
- E-515 Automated Cutting Tools Illustrated Parts Manual
- E-519 Cutting Surface Selection Chart
- E-521-2.1 Easicut 2 Software Manual
- E-522 Air Brush Marking System Manual

Recommended Spare Parts List

<u>Part Number</u>	<u>Description</u>
10-00900-2	Computer Multifunction Board
31-03002	Motion Control Board, MEI
31-B2005	X-Axis Motor
31-S3205-1	Y-Axis Motor
31-03012-2	Motor Amplifiers, Quantity of 2
54-26295	X-Axis Spur Gear, Quantity of 2
31-12660-1	5 & 12 vdc Power Supply
54-D0066	X-Axis Motor Pulley
67-12983	X-Axis Linear Bearing, Quantity of 2
Consult Factory	Replacement Cutting Surface Kit
See E-515 Manual	Replacement Pen
See E-515 Manual	Replacement Cutting Tools

Software Solutions

Eastman offers a wide variety of software to solve even the most difficult tasks. Please consult your nearest Eastman Representative or the Eastman Factory direct for more information.

M9000 Cutting System Familiarization

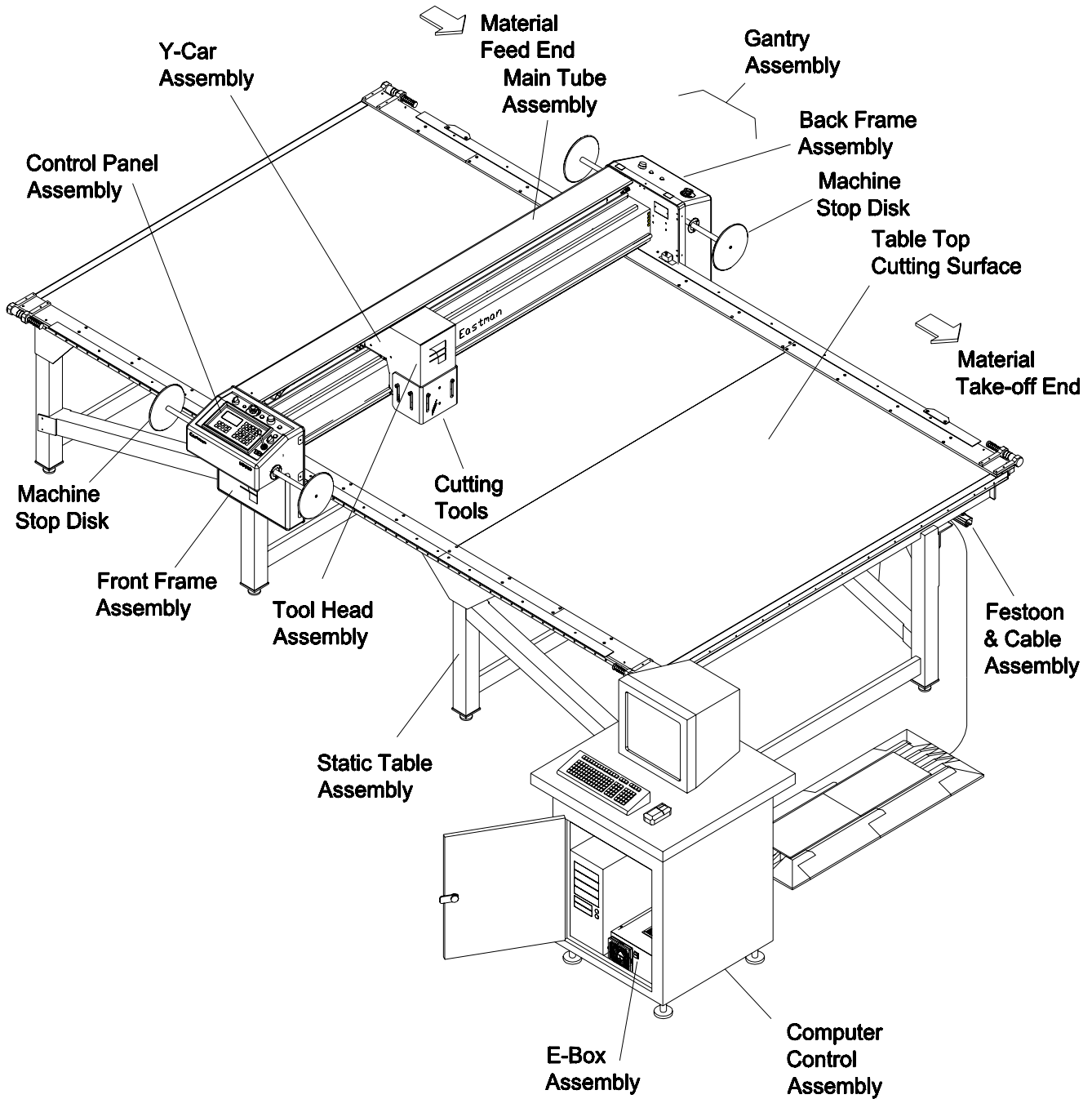
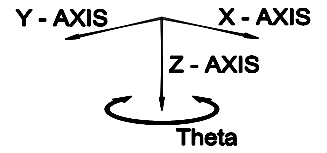

Computer Control Assembly

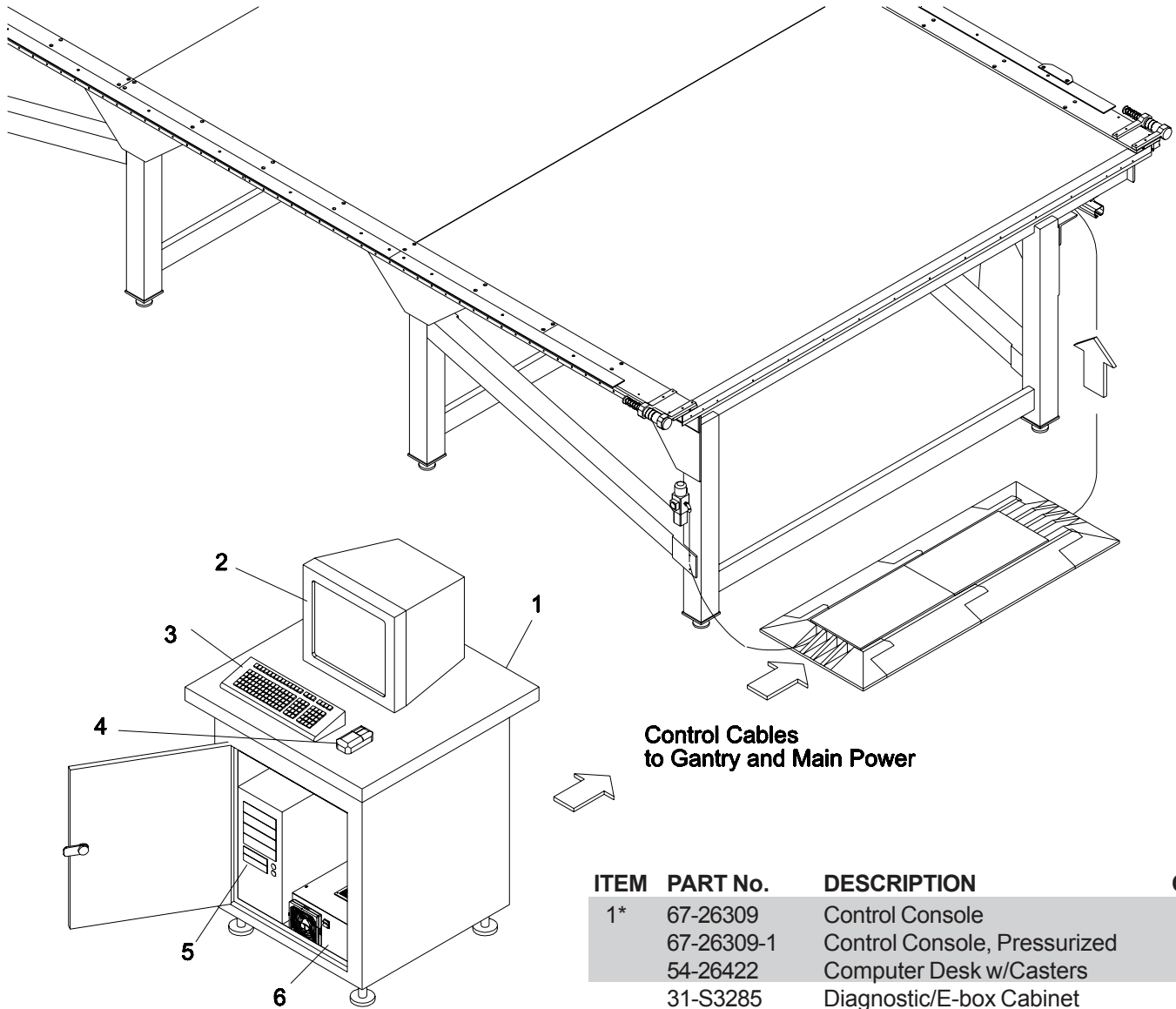

Control Cables
to Gantry and Main Power

ITEM	PART No.	DESCRIPTION	QTY
1*	67-26309	Control Console	1
	67-26309-1	Control Console, Pressurized	1
	54-26422	Computer Desk w/Casters	1
	31-S3285	Diagnostic/E-box Cabinet	1
2	10-26005	15" Color Monitor	1
*	10-26003	17" Color Monitor	1
3	11-00868-02	Computer Keyboard	1
4	11-00054-1	Computer Mouse, Unshielded	1
*	11-00054	Computer Mouse, Shielded	1
5	Consult Factory	Computer (10-26002)	1
	10-00900-2	Multifunction Board	1
	31-S1009	MEI to Multifunction Cable	1
	31-03002	Motion Control Board, MEI	1
6	31-B4001	E-Box Assembly	1

Software Solutions

Eastman offers a wide variety of software to solve even the most difficult tasks. Please consult your nearest Eastman Representative or the Eastman Factory direct for more information.

* Optional

Eastman®

Over a Century of Cutting Expertise

Festoon Kit & Cable Assembly

Note: Table length 72 feet and longer require double Festoon Track and Trolley.

Remote E-Stop Kit (not shown)	
31-S3003-1	Kit for 12'-36' Long Table
31-S3003-2	Kit for 48'-72' Long Table
31-S3003-3	Kit for 84'-108' Long Table

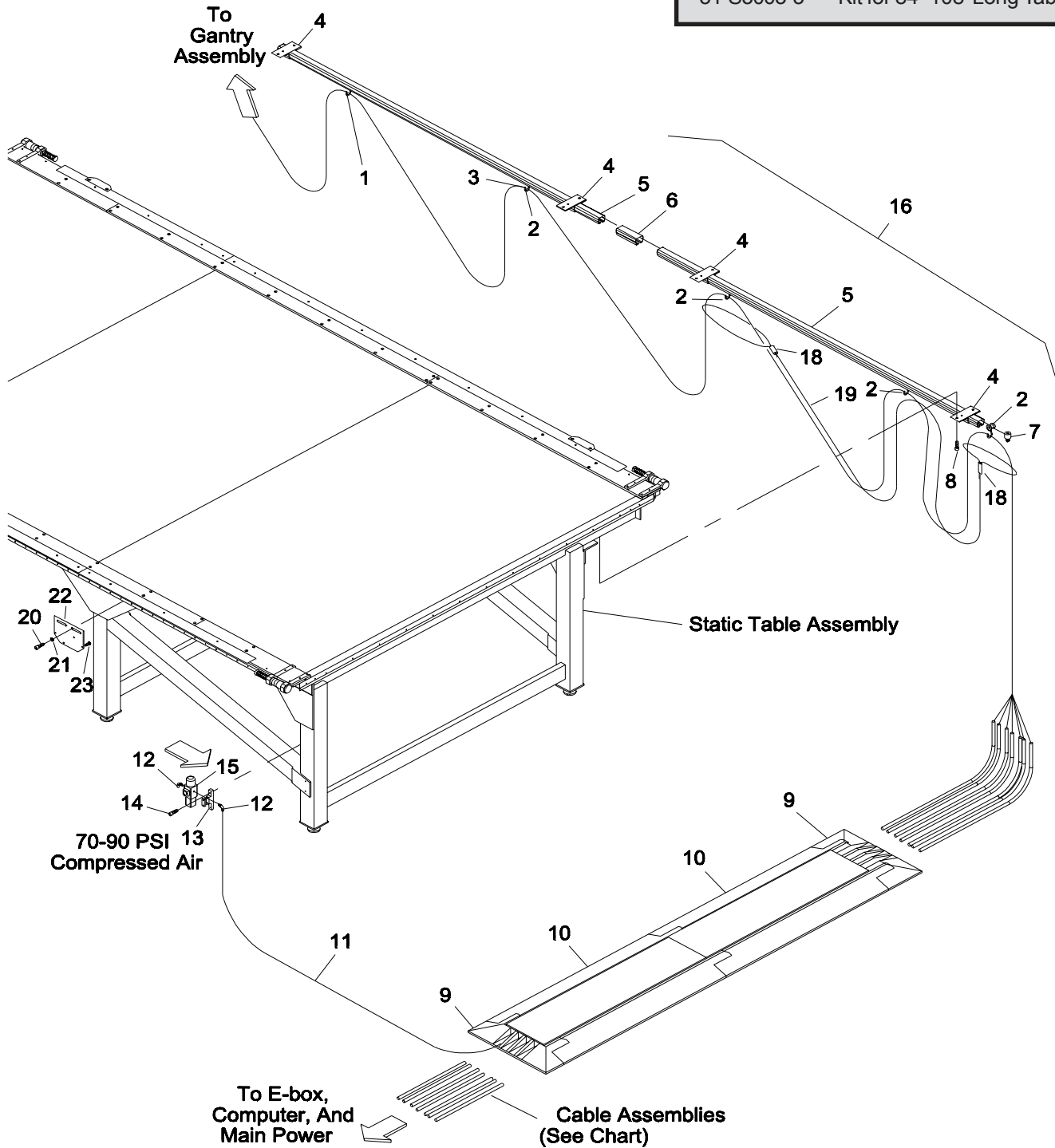

ITEM	PART No.	DESCRIPTION	QTY
1	67-26056	Festoon Trolley, 4 Wheel	1
2	67-26043	Festoon Trolley, Nylon, 2 Wheel	A/R
	67-26044	Festoon Trolley, Steel, 2 Wheel	A/R
3	67-26055	Webbing Strap, Cable Tie	A/R
4	67-26040	Festoon Mounting Track	A/R
5	67-26038	Festoon Roller Track, 144"Long	A/R
	67-26038-4	Festoon Roller Track, 48"Long	A/R
	67-26038-8	Festoon Roller Track, 96"Long	A/R
6	67-26041	Festoon Track Splice	A/R
7	67-26042	Festoon End Stop	1
8	373-99-12	Screw, Self Drill & Tap Type	A/R
9	31-26040	End Cap Set, Cable Protector	1
10	31-26039	Cable Protector, Floor	2
11	27-02996-1	1/4" Air Line	A/R
12	100-13-2	Swivel Elbow, 1/4"	2
13	100-19-9	Filter Mounting Bracket	1
14	373-99-12	Screw, Self Drill & Tap Type	2
15	100-18-2	Filter Regulator	1
16	96-26009-TL	Festoon Rail & Trolley Kit	1
17	54-26689	Rail Mount, Double Festoon Style	A/R
18	E-134	Wire Rope Strain Relief	1
19	TL-261	Clamp, Wire Rope	2
20	335-38-20	Screw, Socket Hd. 3/8-16 x 1-1/4	4
21	410-38	Washer, Flat 3/8	4
22	54-27024	Mounting Plate, Stop	2
23	368-14-16	Screw, Self Tap #14 x 1"	4

A/R- As Required
TL - Table Length

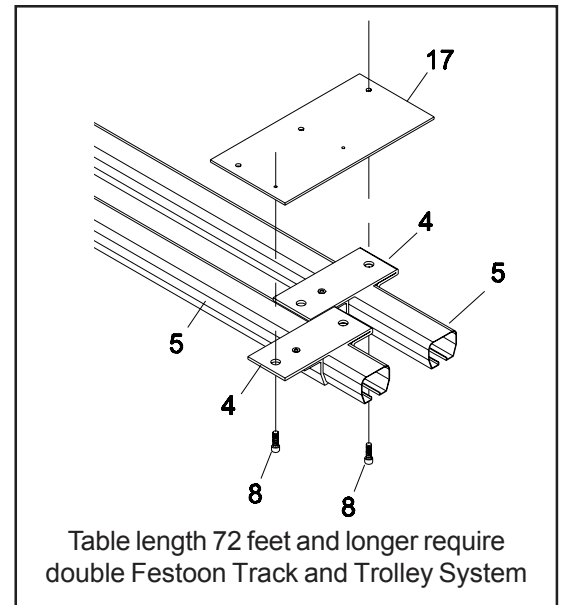

EasiPull Note:

K9000S-TL		X-Axis Cable Assembly Kit	
Part No.		Description	
31-B1013-CL	Main AC Power Cable		
31-B1016-CL	Hall Effect Cable		
31-B1019-CL	Y & Z Motor Cable		
31-B1022-CL	X1-X2 Motor Cable		
31-S1005-CL	UIT Cable		
31-S1020-CL	Encoder Cable		
*31-S1023-CL	I/O Cable		
Emergency Stop Box Assembly			
31-S3003-1	Kit for 12'-36' Long Table		
31-S3003-2	Kit for 48'-72' Long Table		
31-S3003-3	Kit for 84'-108' Long Table		

CL - Cable Length

* EasiPull Note only: Move Male Pin 26 to 27.

Additional Cables	
Part No.	Description
31-B1021-10	Amp I/O Cable, 10 Ft. Long (E-box Only)
31-S3309	Amp I/O Cable, 3 Ft. Long (Diagnostic Cabinet Only)
31-B1013-25	AC Power Cable, E-Box 25 Ft. Long (E-box Only)

Eastman®

Over a Century of Cutting Expertise

Gantry Assembly

G9000MS

Note: MS- Machine Size

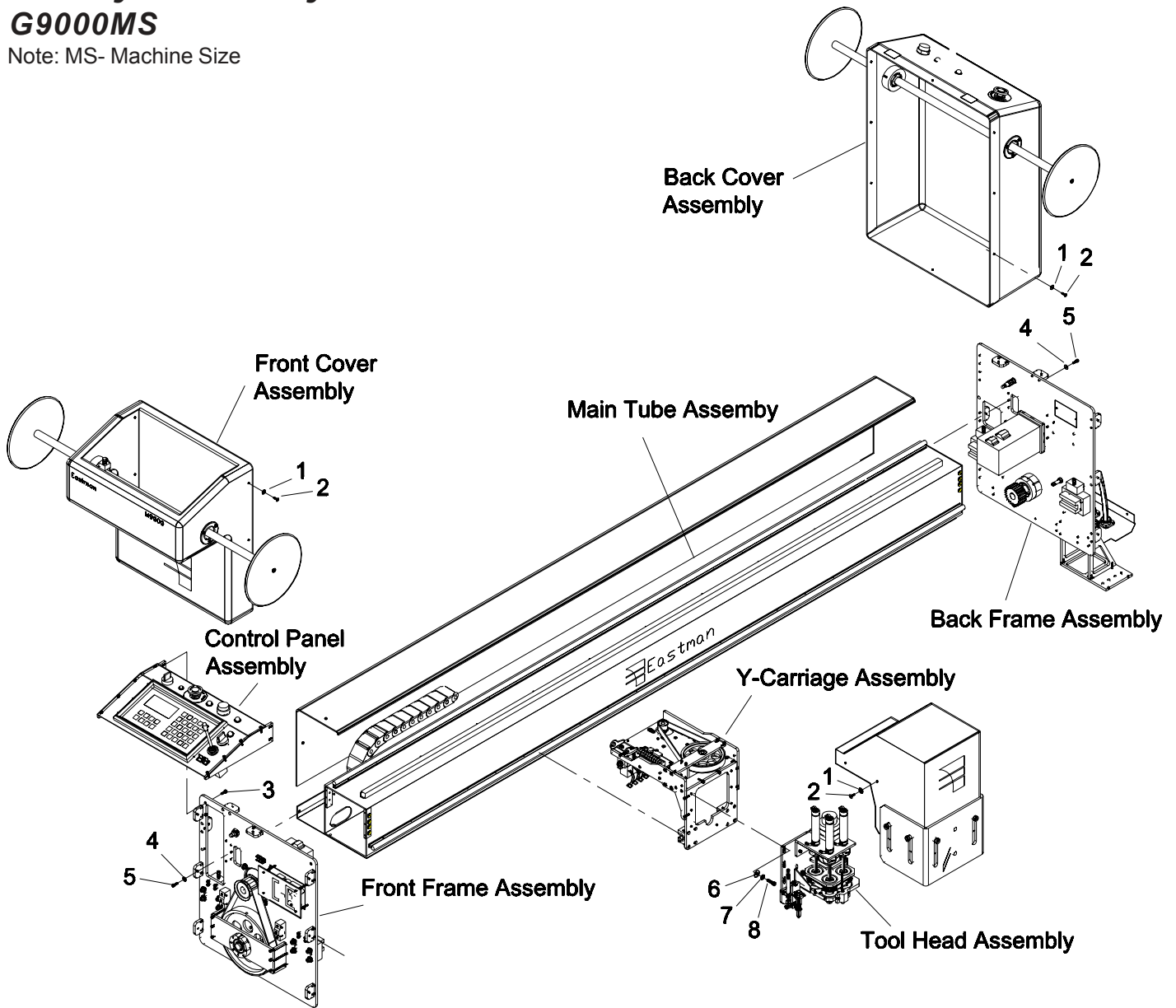

ITEM	PART No.	DESCRIPTION	QTY
1	409-99	Finish Washer	A/R
2	333-93-8S	Screw, Cover	A/R
3	335-93-8	Screw, Socket #8-32 x 1/2	4
4	410-080	Washer, Flat #8	12
5	335-93-10	Screw, Socket #8-32 x 5/8	12
6	410-010	Washer, Flat #10	6
7	402-010	Washer, Lock #10	6
8	335-102-10	Screw, Socket #10-32 x 5/8	6

Front Cover Assembly

54-03004-2

ITEM	PART No.	DESCRIPTION	QTY
1	333-34-12Z	Screw, Button Hd. 1/4-20 x 3/4	2
2	54-26419	Stop Disk	2
3	54-26420	Rod, Stop Disk	1
4	333-102-8S	Screw, Button Hd. 10-32 x 1/2	6
5	54-26423	End Cap	2
6	91-26002	Decal, Small Eastman	1
7	91-00554	Decal, M9000	1
8	91-26005	Decal, Logo	1
9	54-C0338-2	Operator Side Cover	1
10	67-26311	Slide Bearing	2
11	54-26421	Bearing Mount	1
12	318-86-6	Screw, Pan Head #8-32 x 3/8	2
13	404-080	Lock Washer, #8 Internal	2
14	54-26426	Switch Bracket	1
15	11-1193	limit Switch	1
16	404-040	Lock Washer, #4 External	2
17	313-81-8	Screw, Round Hd. #4-40 x 1/2	2
18	54-26422	Bearing & Switch Mount	1
19	9078-003	Spring Plunger, 3/8-16	1
20	205-38	Hex Nut, 3/8-16	1

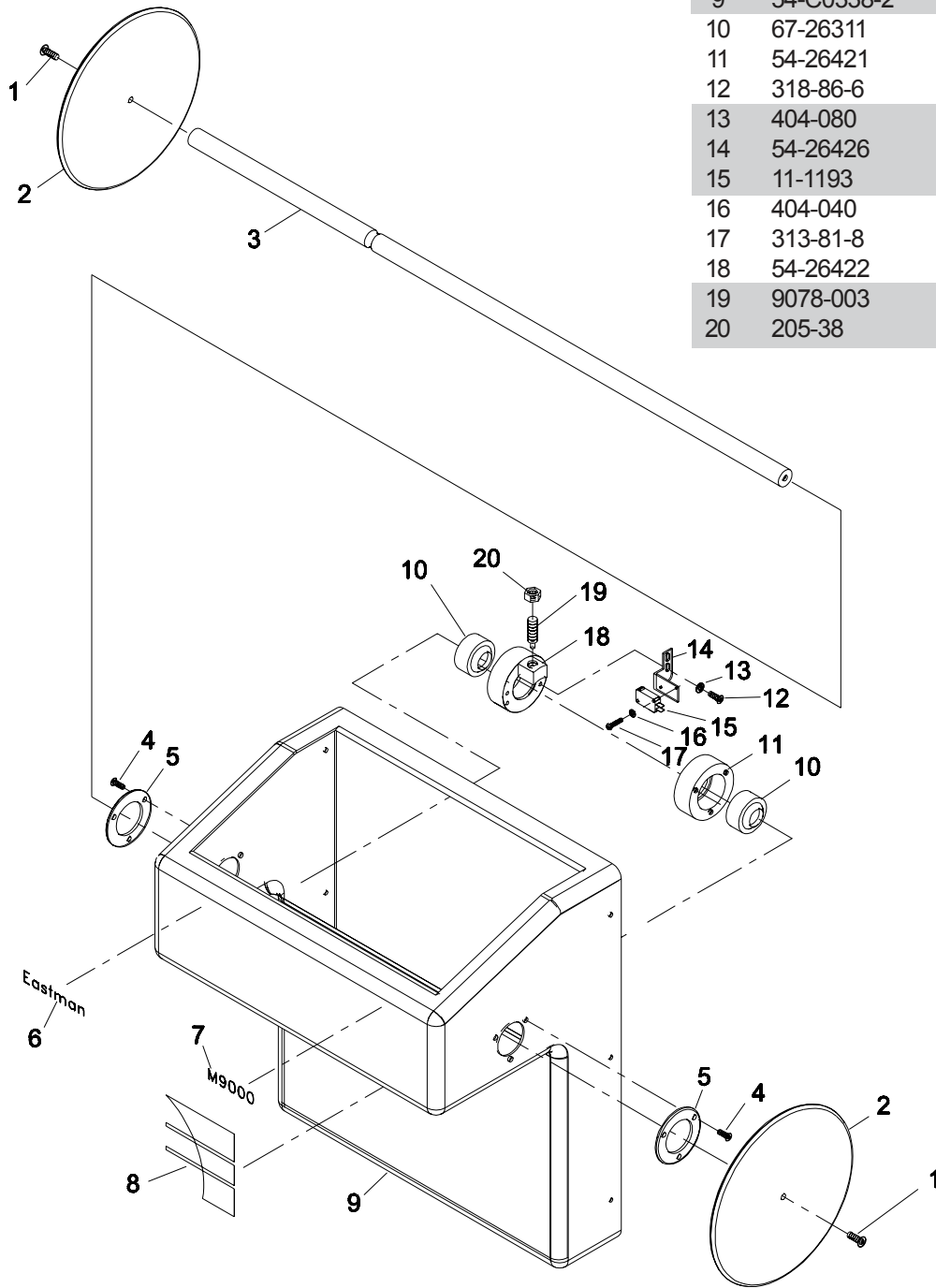

Eastman®

Over a Century of Cutting Expertise

Back Cover Assembly 31-S3005-2

ITEM	PART No.	DESCRIPTION	QTY
12	11-1193	limit Switch	1
13	404-040	Lock Washer, #4 External	2
14	313-81-8	Screw, Round Hd. #4-40 x 1/2	2
15	54-26422	Bearing & Switch Mount	1
16	9078-003	Spring Plunger, 3/8-16	1
17	205-38	Hex Nut, 3/8-16	1
18	91-26002	Decal, Small Eastman	1
19	91-00554	Decal, M9000	1

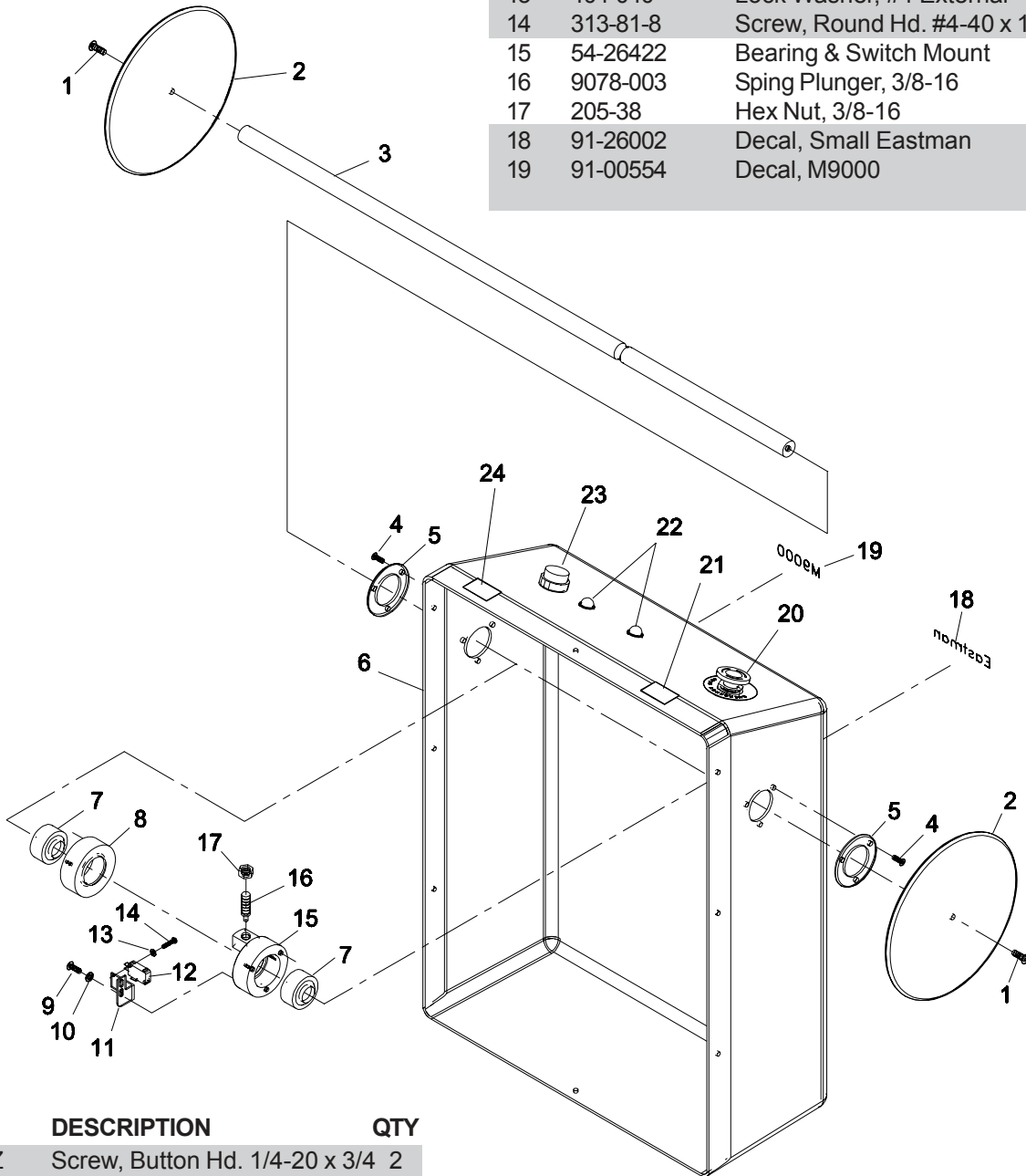

ITEM	PART No.	DESCRIPTION	QTY
1	333-34-12Z	Screw, Button Hd. 1/4-20 x 3/4	2
2	54-26419	Stop Disk	2
3	54-26420	Rod, Stop Disk	1
4	333-102-8S	Screw, Button Hd. 10-32 x 1/2	6
5	54-26423	End Cap	2
6	54-C0339-2	Non-Operator Side Cover	1
7	67-26311	Slide Bearing	2
8	54-26421	Bearing Mount	1
9	318-86-6	Screw, Pan Head #8-32 x 3/8	2
10	404-080	Lock Washer, #8 Internal	2
11	54-26426	Switch Bracket	1

ITEM	PART No.	DESCRIPTION	QTY
20	31-12943	Mushroom Switch, Red	1
	31-00831	Switch Contact, NO	1
	31-00832	Switch Contact, NC	1
	91-26011	Decal, Yellow Emergency Stop	1
21	91-00558	Decal, Emergency, Off	1
22	31-00834	Light, 12v Red	2
23	31-12628	Pause Switch, Yellow	1
	31-00831	Switch Contact, NO	1
24	91-26006	Decal, Pause	1

Control Panel Assembly

31-S9003

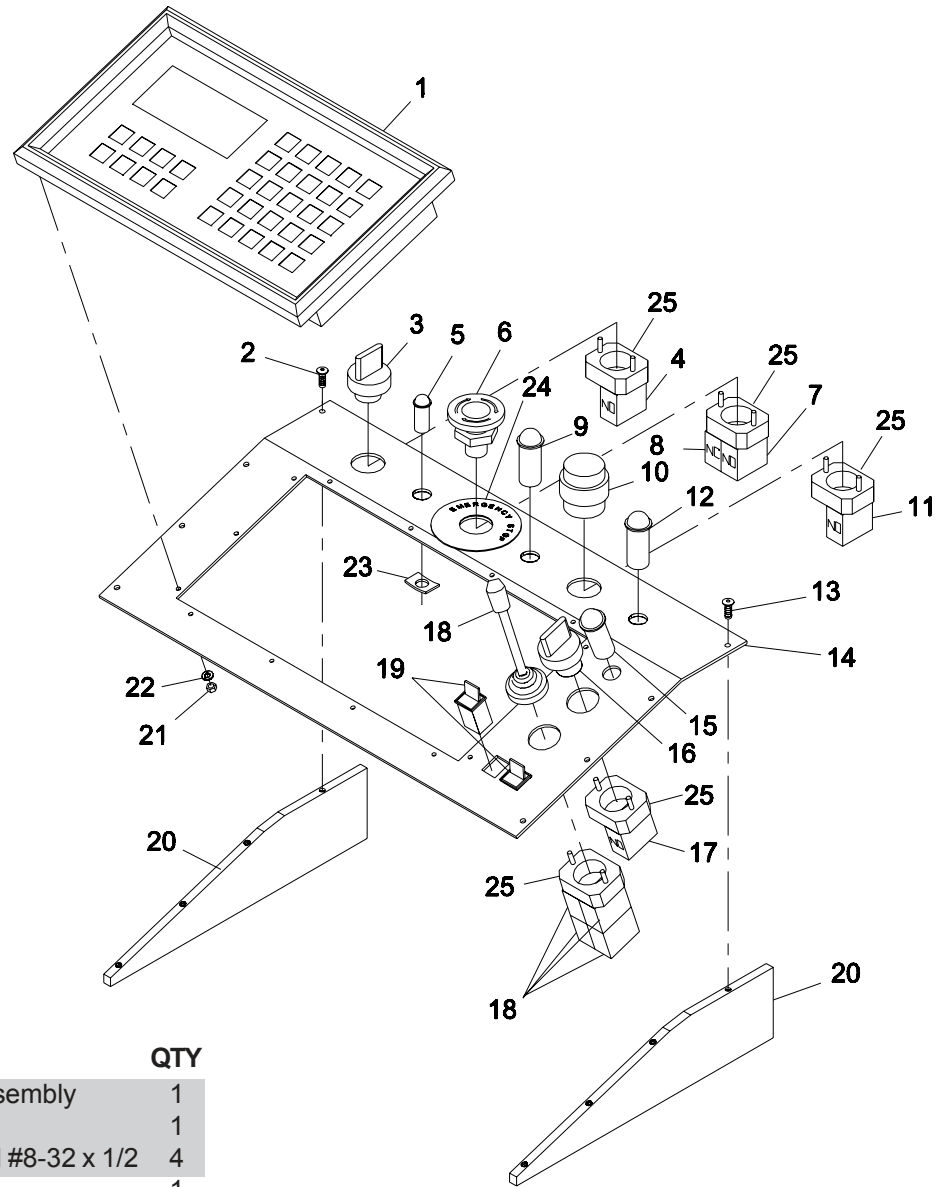

ITEM	PART No.	DESCRIPTION	QTY
1	31-26035	Control Panel Assembly	1
	79-00417	Key Pad Label	1
2	333-93-8	Screw, Button Hd #8-32 x 1/2	4
3	31-00828	Selector Switch	1
4	31-00831	Switch Contact, NO	1
	31-00830	Base	1
5	31-00839	Indicator Light, 125VAC Green	1
6	31-12943	Stop Button, Mushroom	1
7	31-00831	Switch Contact, NO	1
8	31-00832	Switch Contact, NC	1
9	31-00834	Indicator Light, Red	1
10	31-12628	Switch, Yellow Push	1
11	31-00831	Switch Contact, NO	1
12	31-00834	Indicator Light, Red	1
13	333-93-8	Screw, Button Hd #8-32 x 1/2	4
14	54-C0335-2	Plate, Control Panel	1
15	31-00838	Indicator Light, 12V Green	1

ITEM	PART No.	DESCRIPTION	QTY
16	31-00828	Selector Switch	1
17	31-00831	Switch Contact, NO	1
18	31-12947	Joy Stick	1
19	31-00991	Switch, Lever Style	2
20	54-C0334	Panel Support	2
21	203-86	Hex Nut, #6-32	14
22	402-060	Lock Washer	14
23	4C2-111	Arched Speed Nut	4
24	91-26011	Decal, Emergency Stop	1
25	31-00830	Switch Base	5

Eastman®

Over a Century of Cutting Expertise

Front End Plate Assembly

68-03002

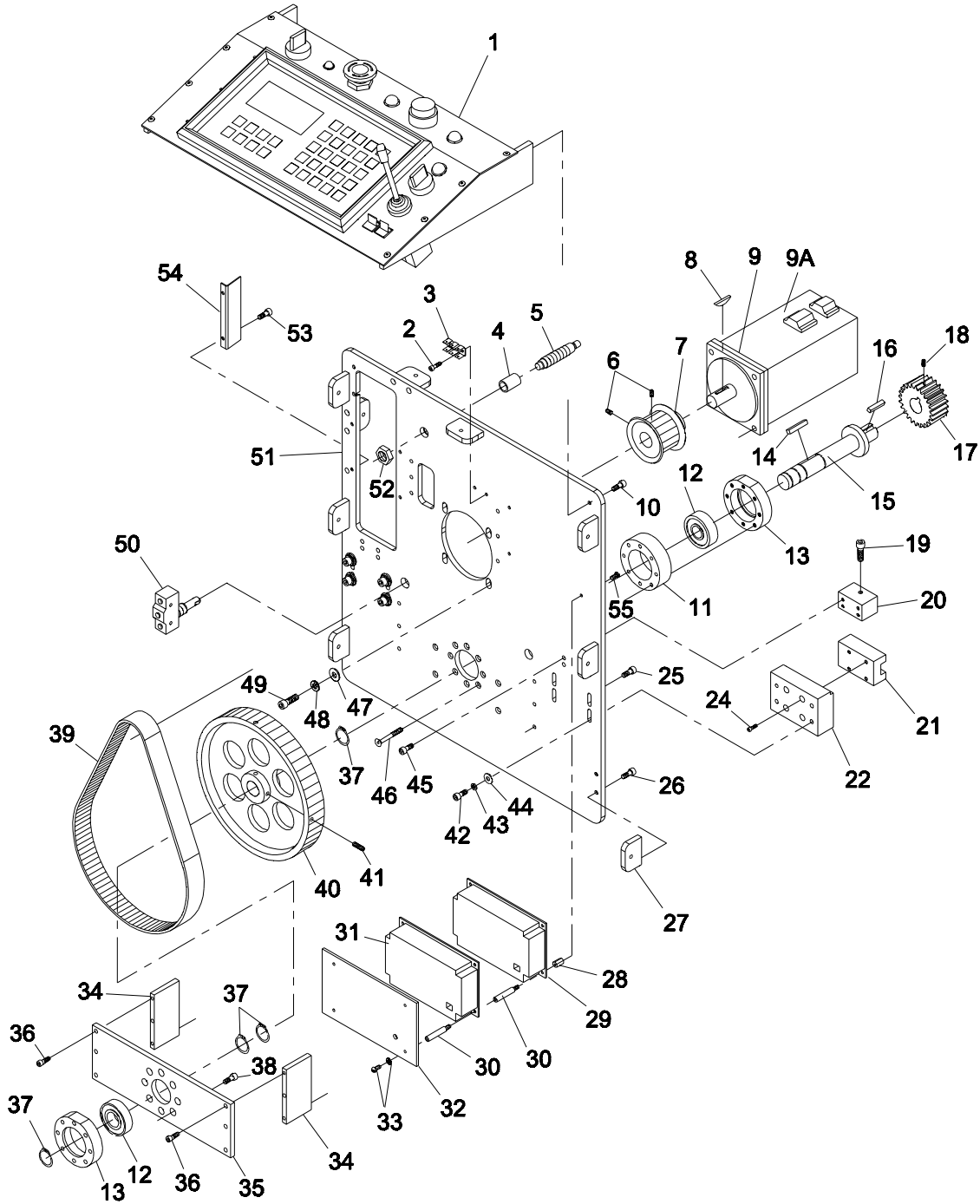

ITEM	PART No.	DESCRIPTION	QTY
*1	31-S9003	Control Panel Assembly	1
2	333-86-4	Screw, Button Hd. #6-32 x 1/4	2
3	31-03101	Ground Terminal	1
4	67-01053	Collar, Stop	1
5	67-01051-1	Shock Absorber	1
6	342-93-4	Setscrew, #8-32 x 1/4	2
7	54-D0066	Motor Pulley	1
8	**	Key, part of motor assembly	1
9	54-26019	Motor Mounting Plate	1
*9A	31-B2005	X1-Axis Motor with Harness	1
10	335-93-8	Screw, Socket Hd. #8-32 x 1/2	4
11	54-LC095	Bearing Spacer Shim	1
12	67-12984	Bearing	2
13	54-D0019	Bearing Housing	2
14	9063-104	Key, .188 x .188 x .859	1
15	54-D0276	Drive Shaft	1
16	9063-010	Key, .188 x .188 x .734	1
17	54-26295	Spur Gear	1
18	342-102-5	Setscrew #10-32 x 5/16	2
19	335-35-24	Screw, Socket 1/4-28 x 1 1/2	2
20	54-LC098	Backlash Adjuster	2
21	67-12983	Linear Bearing	2
22	54-LC097	Rail Car Connector	2
23	-	-	
24	341-4-12	Screw, Socket m4 x 12mm	8
25	335-93-8	Screw, Socket Hd. #8-32 x 1/2	6
26	335-93-8	Screw, Socket Hd. #8-32 x 1/2	18
27	54-C0306	Cover Mounts	9
28	11-1940	Spacer, 7/16 Long	4
29	31-26012-15	Power Supply, 5vdc	1
30	11-1981	Spacer, 1-1/8 Long	8
31	31-26012-16	Power Supply, 12vdc	1

ITEM	PART No.	DESCRIPTION	QTY
32	54-26025	Power Supply Shield	1
33	404-060	Star Lock Washer	4
	333-86-6	Screw, Socket Hd. #6-32 x 3/8	4
31	31-26012-16	Power Supply, 12v	1
32	404-060	Star Lock Washer	4
33	313-86-32	Screw, Round Head #6-32 x 2	4
34	54-D0485	Drive Standoff Plate	2
35	54-D0022-2	Shaft Support	1
36	335-93-8	Screw, Socket Hd. #8-32 x 1/2	6
37	67-D0216-5	Snap Ring	4
38	332-102-10	Screw, Flat Hd. #10-32 x 5/8	8
39	67-02963-1	Drive Belt, htd	1
40	54-D0065	Pulley, Large	1
41	342-93-4	Setscrew, #8-32 x 1/4	2
42	335-102-10	Screw, Flat Hd. #10-32 x 5/8	8
43	402-010	Lock Washer #10	8
44	410-010	Flat Washer #10	8
45	335-102-10	Screw, Socket #10-32 x 5/8	8
46	332-102-20	Screw, Flat Hd. #10-32 x 1 1/4	8
47	410-34	Flat Washer, 1/4	2
48	402-34	Lock Washer, 1/4	4
49	335- 34-20	Screw, Socket 1/4-20 x 1 1/4	2
	333-34-20	Screw, Button 1/4-20 x 1 1/4	2
*50	31-00922	Roller Switch, 90 degree spdt	2
51	54-C0300	Operator Side Plate, Right	1
52	206-44	Nut, Hex Jam 1/2-20	2
*53	335-93-4	Screw, Socket #8-32 x 1/4	4
*54	54-26224	E-chain Funnel	2
55	333-86-8	Screw, Socket Hd. #6-32 x 1/2	4

* Not included in assembly

** Required for table length 72' and higher

A/R -As Required

Eastman®

Over a Century of Cutting Expertise

Back End Plate Assembly

68-03001

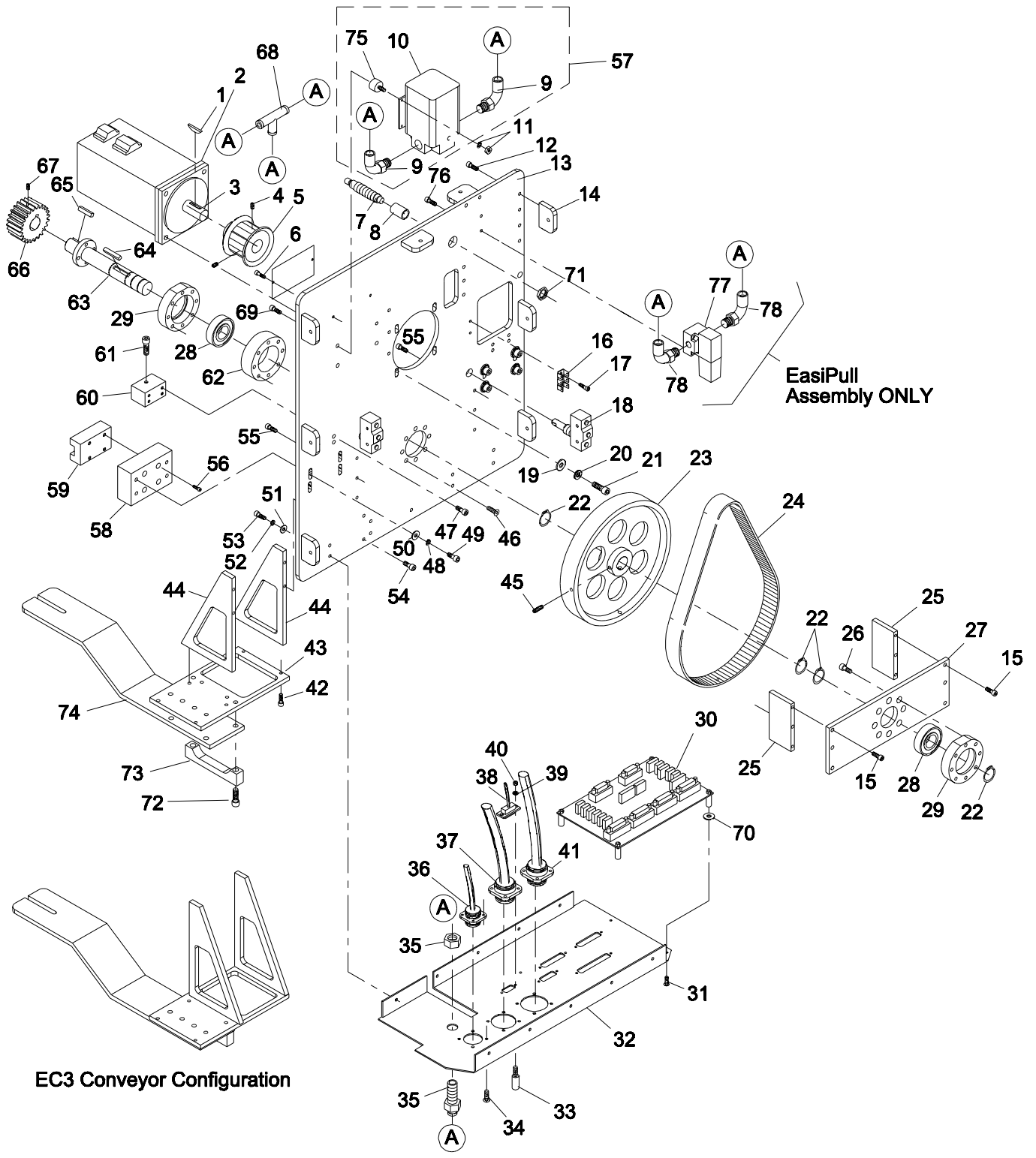

ITEM	PART No.	DESCRIPTION	QTY
1	**	Key, part of motor assembly	1
2	54-26019	Motor Mounting Plate	1
3	31-B2000	X2-Axis Motor with Harness	1
4	342-93-4	Setscrew, #8-32 x 1/4	2
5	54-D0066	Motor Pulley	1
6	333-86-4	Screw, Button Hd. #6-32 x 1/4	2
7	67-01051-1	Shock Absorber	1
8	67-01053	Collar, Shock Absorber	1
9	100-13-2	Elbow 1/4 NPT x 1/4"	2
10	27-20001	Air Control Regulator	1
11	203-93	Hex Nut, #8-32	4
	404-080	Lock Washer, #8	4
12	335-93-8	Screw, Socket Hd. #8-32 x 1/2	18
13	54-C0301	Side Plate, Left	1
14	54-C0306	Cover Mounts	9
15	335-93-8	Screw, Socket Hd. #8-32 x 1/2	6
16	11-919	Ground Terminal	1
17	333-86-4	Screw, Button Hd. #6-32 x 1/4	2
18	31-00922	Roller Switch, 90 degree spdt	2
19	410-34	Flat Washer, 1/4	2
20	402-34	Lock Washer, 1/4	4
21	335-34-20	Screw, Socket 1/4-20 x 1 1/4	2
	333-34-20	Screw, Button 1/4-20 x 1 1/4	2
22	67-D0216-5	Snap Ring	4
23	54-D0065	Pulley, Large	1
24	67-02963-1	Drive Belt,htd	1
25	54-D0485	Drive Standoff Plate	2
26	332-102-10	Screw, Flat Hd. #10-32 x 5/8	8
27	54-D0022-2	Shaft Support	1
28	67-12984	Bearing	2
29	54-D0019	Bearing Housing	2
30	10-00903-2	X-Axis Board	1
31	305C8-1	Screw, Pan Hd. #4-40 x 1/4	4
32	54-C0342-1	Electrical Pan	1
33	67-01005	Locking Screw Kit	1
34	333-86-4	Screw, Button Hd. #6-32 x 1/4	12
35	100-17-1	1/4" Fitting	1
36	31-02693-2	3-Pin Circular Connector (only)	1
37	31-00976	8-Pin Connector, Small (only)	1
	31-02973	Strain Relief	1
	31-12929	10mm Boot	1
	31-12930	12mm Boot	1

Wide Gantry Machines Only
Double Bearing Kit 96-26066

ITEM	PART No.	DESCRIPTION	QTY
38	31-S1010-MS	UIT Cable	1
39	67-01005	Locking Screw Kit (part of)	1
40	67-01005	Locking Screw Kit (part of)	1
41	31-00972	8-Pin Connector, Large (only)	1
	31-02973	Strain Relief	1
	31-12929	10mm Boot	1
	31-12930	12mm Boot	1
42	335-93-8	Screw, Socket Hd. #8-32 x 1/2	4
43	54-C0318	E-Chain Mount	1
44	54-C0435	E-Chain Side Mount	2
45	342-93-4	Setscrew, #8-32 x 1/4	2
46	332-102-20	Screw, Flat Hd. #10-32 x 1 1/4	8
47	335-102-10	Screw, Socket #10-32 x 5/8	8
48	402-010	Lock Washer #10	8
49	335-102-10	Screw, Socket #10-32 x 5/8	8
50	410-010	Flat Washer #10	8
51	410-080	Flat Washer #8	4
52	402-080	Lock Washer #8	4
53	335-93-8	Screw, Socket Hd. #8-32 x 1/2	4
54	335-93-10	Screw, Socket Hd. #8-32 x 5/8	4
55	335-93-8	Screw, Socket Hd. #8-32 x 1/2	6
56	341-4-12	Screw, Socket m4 x 12mm	8
57	31-S9005	Pressure Regulator Assembly	1
58	54-LC097	Rail Car Connector	2
59	67-12983	Linear Bearing	2
60	54-LC098	Backlash Adjuster	2
61	335-35-24	Screw, Socket 1/4-28 x 1 1/2	2
62	54-LC095	Bearing Spacer Shim	1
63	54-D0276	Drive Shaft	1
64	9063-104	Key, .188 x .188 x .859	1
65	9063-010	Key, .188 x .188 x .734	1
66	54-26295	Spur Gear	1
67	342-102-5	Setscrew #10-32 x 5/16	4
68	100-14-1	Tee Fitting, 1/4"	1
69	333-102-8	Screw, Button Hd #10-32 x 1/2	4
70	410-060	Flat Washer, #6	4
71	206-44	Nut, Hex Jam 1/2-20	1
72	335-34-20	Screw, Socket 1/4-20 x 1 1/4	2
73	54-C0320-1	Cable Clamp	1
74	54-26299-1	Pull Bracket, Festoon	*1
	54-26299-2	Pull Bracket, DoubleTrack only	*1
75	65-26024	Vibration Dampener	4
76	335-93-8	Screw, Socket Hd. #8-32 x 1/2	2
77	100-18-21	Valve, Easi Pull	1
78	100-13-2	Elbow 1/4 NPT x 1/4"	2

A/R -As Required
-MS Machine Size
* - not Included

(A) 27-02996-1 Air Tubing, 1/4" (not shown) A/R

Eastman®

Over a Century of Cutting Expertise

Main Tube Assembly

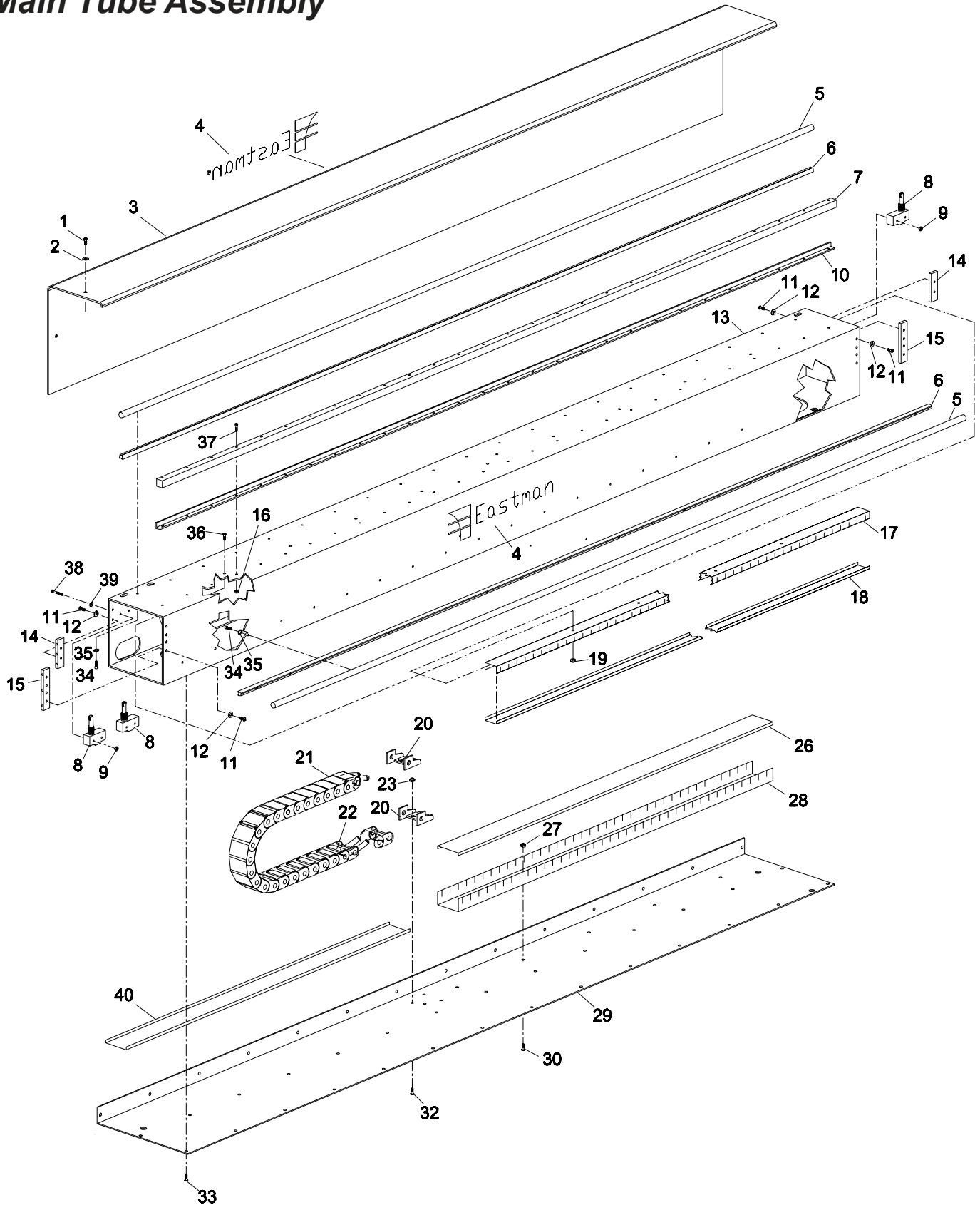

ITEM	PART No.	DESCRIPTION	QTY
1	333-93-8S	Screw, Button Hd. #8-32 x 1/2	A/R
2	409-99	Finish Washer	A/R
3	54-C0340-MS	E-Chain Cover	1
	54-26133-MS	Tube Cover (Larger Machines only)	1
4	91-26003	Decal, Eastman 4" Medium	2
5	67-C0219-MS	Linear Rail	2
6	67-C0220	Linear Rail Mount	A/R
7	67-12990-1	Gear Rack, 96" 20p	A/R
8	31-00921	Roller Switch	3
9	211-86	Stop Nut, #6-32	6
10	54-C0411-MS	Rack Support	1
11	335-102-6	Screw, Socket Hd. 10-32 x 3/8	12
12	410-010	Flat Washer, #10	12
13	54-C0302-MS	Main Tube	1
14	54-C0305-1	Insert, Short	2
15	54-C0305-2	Insert, Long	2
16	211-86	Stop Nut, #6-32	A/R
17	70-26001	Duct, 1 x 1.5	A/R
18	67-02634	Duct Cover, 1"	A/R
19	211-102	Stop Nut, #10-32	A/R
20	67-26177	E-Chain Mounting Set	1
21	67-26111	E-Chain (Sold by the Foot)	A/R
22	67-26178	E-Chain Cable Separators	A/R
23	211-34	Stop Nut, 1/4-20	2
24	-		
25	-		

Y-Cable Kit (31-S3207-ms) Not Shown

31-S3204-MS	Multi-Tool Y-Axis Cable
31-S3206-MS	Y/Z Power Cable

ITEM	PART No.	DESCRIPTION	QTY
26	70-26005	Duct, 2" Wide	A/R
27	211-102	Stop Nut, #10-32	A/R
28	70-26006	Duct Cover, 2"	A/R
29	54-C0410-MS	Belly Pan	1
30	333-102-6	Screw, Button Hd. #10-32 x 3/8	A/R
31	-		
32	333-34-8	Screw, Button Hd. #1/4-20 x 1/2	2
33	333-102-4	Screw, Button Hd. #10-32 x 1/4	A/R
34	335-86-12	Screw, Socket Hd. #6-32 x 3/4	A/R
35	402-060	Lock Washer, #6	A/R
36	333-102-6	Screw, Button Hd. #10-32 x 3/8	A/R
37	333-86-16	Screw, Button Hd. #6-32 x 1	A/R
38	333-86-16	Screw, Button Hd. #6-32 x 1	6
39	410-060	Flat Washer, #6	6
40	67-26081	Duct Cover, 2.5	A/R

A/R -As Required
MS - Machine Size

- (A) 27-02996-1 Air Tubing, 1/4" (not shown) A/R
- (B) 27-02996-2 Air Tubing, 5/32" (not shown) A/R

Main Tube Cable Kit (96-26074-ms) Not Shown

31-S1010-MS	UIT Touch Screen Cable
31-S3006-MS	Dual 5&12 Power Supply Cable
31-S3341-MS	AC Power Harness
31-S3002-MSXH	Gantry Switch X1-Home Cable
31-S3002-MSYH	Gantry Switch Y-Home Cable
31-S3002-MSYL	Gantry Switch Y-Limit Cable
31-S3009-MS	Tool Control Cable
31-S3010-MS	E-Off/Pause Cable

Eastman®

Over a Century of Cutting Expertise

Y-Carriage Assembly

68-03005

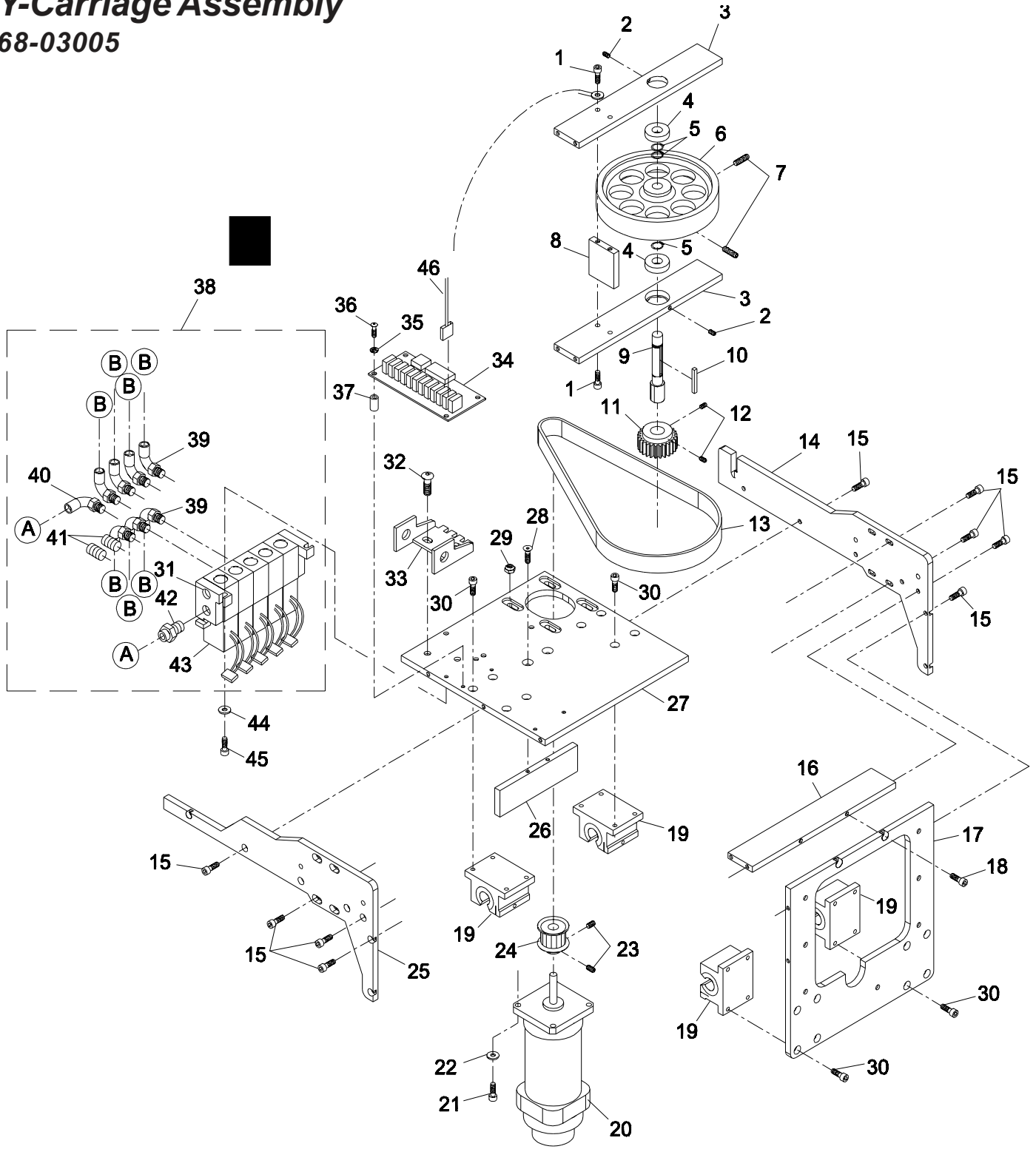

ITEM	PART No.	DESCRIPTION	QTY
1	335-93-8	Screw, Socket Hd. #8-32 x 1/2	4
2	342-86-4	Setscrew, #6-32 x 1/4	2
3	54-H0232	Y-Car Backlash Plate	2
4	67-00520	Bearing, Y-Car Pulley	2
5	67-D0216-1	Snap Ring, 3/8	3
6	54-12985	Large Y-Car Pulley, 72T	1
7	342-102-5	Setscrew, #10-32 x 5/16	2
8	54-H0233	Backlash Cross Plate	1
9	54-D0267	Y-Car Drive Shaft	1
10	67-9063-003	1/8" Square Key	1
11	54-02934-3	Small Y-Car Pulley, 25T	1
12	342-86-4	Setscrew, #6-32 x 1/4	2
13	67-D0215	Y-Car Drive Belt, 113T	1
14	54-H0235	Y-Car Left Side Plate	1
15	335-93-8	Screw, Socket Hd. #8-32 x 1/2	44
16	54-H0231	Y-Car Horiz. Plate, 2nd	1
17	54-H0236	Y-Car Main Vertical Plate	1
	54-H0236-1	Y-Car Plate, Foam Cutter only	1
18	335-93-8	Screw, Socket Hd. #8-32 x 1/2	2
19	67-06818	Y-Car Bearing Assembly	4
*20	31-S3205-1	Y-Car Motor w/Connector	1
21	335-93-12	Screw, Socket Hd. #8-32 x 3/4	4
22	402-080	Lock Washer, #8	4
23	342-93-3	Setscrew, #8-32 x 3/16	2

ITEM	PART No.	DESCRIPTION	QTY
24	54-D0214	Y-Car Motor Pulley, 15T	1
25	54-H0234	Y-Car Right Side Plate	1
26	54-H0341	Home Plate	1
27	54-H0230	Y-Car Main Plate	1
28	332-86-8	Screw, Flat Hd. #6-32 x 1/2	2
29	211-93	Lock Nut, #8-32	4
30	335-102-8	Screw, Socket Hd. 10-32 x 1/2	16
31	27-H0410	1/4 NPT Plug	2
32	333-34-6	Screw, Button Hd. 1/4-20 x 3/8	2
*33	67-26177	E-Chain End Bracket	1
34	10-00904-2	Y-Axis Board	1
35	404-060	Lock Washer, #6	4
36	333-86-8	Screw, Button Hd. #6-32 x 1/2	4
37	27-02996-1	Spacer Tubing (sold by foot)	A/R
*38	68-26011	Solenoid Ass'y, 3 Station, 12v	1
	68-26011-1	Solenoid Ass'y, 4 Station, 12v	1
	68-03009	Solenoid Ass'y, 5 Station, 12v	1
	68-03009-2	Solenoid Ass'y, 6 Station, 12v	1
39	100-13-3	5/32" Swivel Elbow	7
40	100-13-7	1/4" Swivel Elbow	1
41	27-H0409	1/8 NPT Plug	1
42	100-11-2	1/4" Fitting	1
43	27-H0382	5 Station Solenoid Block (without Electrical Connector)	1
	27-H0382-2	1 Station Replacement Solenoid (without Electrical Connector)	1
44	410-010	Lock Washer, #10	2
45	335-102-10	Screw, Socket Hd, #10-32 x 5/8	2
46	31-26461	Grounding Wire	1

* Not included in assembly

A/R -As Required

(A)	27-02996-1	Air Tubing, 1/4"	A/R
(B)	27-02996-2	Air Tubing, 5/32"	A/R

Eastman®

Over a Century of Cutting Expertise

**Tool Head Assembly
H9900-3A**

Refer to
Automated Cutting Tools Manual
E-515 for latest Available Tools

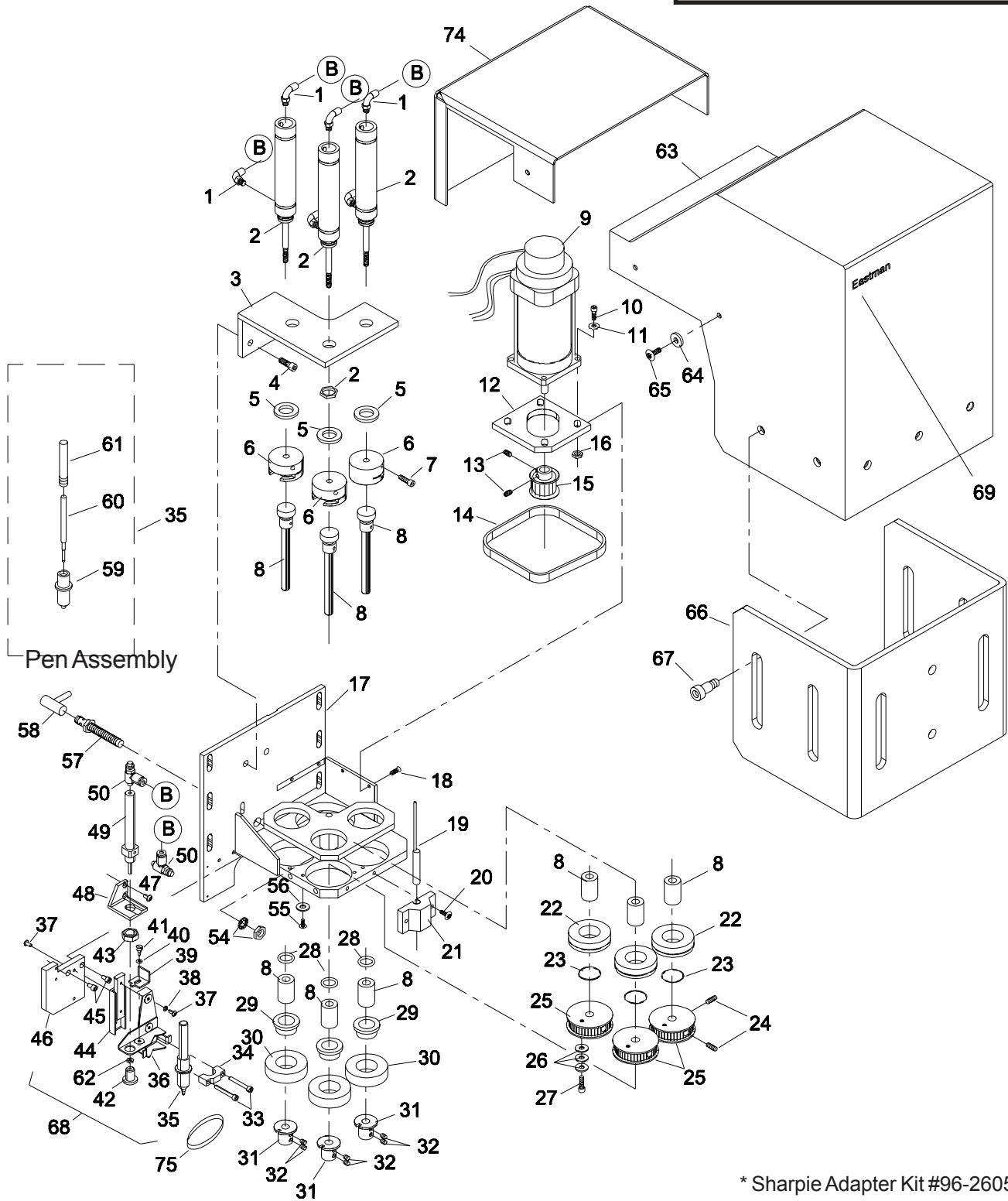

ITEM	PART No.	DESCRIPTION	QTY
1	100-13-3	Swivel Elbow, 1/8 npt x 5/32	6
2	67-26092-2	Air Cylinder	3
	54-26152	Jam Nut, 5/8-18	3
3	67-26190	Cylinder Mounting Bracket	1
4	335-34-8	Screw, Socket Hd. 1/4-20 x 1/2	4
5	54-26229	Bumper	3
6	54-26232	Cylinder Coupling, Non-Rotating	3
7	335-102-10	Screw, Socket Hd. #10-32 x 5/8	3
8	54-26234	Shaft & Bearing Assembly	3
9	31-S3205-1	Z-Motor, Servo w/Connector	1
10	335-93-14	Screw, Socket Hd. #8-32 x 7/8	4
11	402-080	Washer, Lock #8	4
12	67-26188	Motor Mounting Plate	1
13	345-93-4	Setscrew, #8-32 x 1/4	2
14	67-12972-1	Belt, 115t x 3 mm	1
15	67-26054	Pulley, 22t x 3mm	1
16	211-93	Stop Nut, #8-32	4
17	67-26191	H9900-3A Tool Head Frame	1
18	332-102-6	Screw Flat Hd. 10-32 x 3/8	4
19	81-00002	Laser Pointer	1
20	333-93-8	Screw, Button Hd. #8-32 x 1/2	2
21	54-H0403	Mount, Laser Pointer	1
22	67-26184	Bearing, 16mm ID	3
23	54-26230	Spacer	3
24	65-26009	Setscrew, #6-32 x 1/4	6
25	54-12971	Pulley, 44t x 3mm	3
26	402-010	Washer, Lock #10	3
27	335-102-8	Screw, Socket Hd.#10-32 x 1/2	1
28	67-26185	Cushion Ring	3
29	54-26231	Bearing Adapter	3
30	67-26186	Bearing 20mm ID	3
31	54-26021-1	Tool Adaptor	3
32	65-26016	Setscrew, #8-32 X 7/64	6
33	335-86-16	Screw, Socket Hd. #6-32 x 1	2
34	54-H0213	Pen Holder	1
35	68-26027	Pen Assembly	1
36	54-26272	Pen Mounting Bracket	1
37	333-3-6	Screw, Button Hd. 3m x 6m	4
38	402-040	Washer, Lock #4	2

ITEM	PART No.	DESCRIPTION	QTY
39	54-26269	Slide Lock	1
40	67-03004	O-Ring	1
41	355-2-2	Shoulder Bolt, 1/8 x 1/8	1
42	54-26270	Cylindar End	1
43	67-26224	Cylindar Nut	2
44	67-26223	Pen Mount Slide Bearing	1
45	335-86-4	Screw, Socket Hd. #6-32 x 1/4	2
46	54-26301-1	Pen Mounting Plate	1
47	333-86-4	Screw, Button Hd. #6-32 x 1/4	2
48	54-26273	Cylindar Mounting Bracket	1
49	67-26224	Pen Cylinder	1
50	100-18-19	Flow Control Fitting	2
51	-		
52	-		
53	-		
54	31-26183	Washer & Nut, (Part of #57)	1
55	333-102-6	Screw, Button Hd. 10-32 x 3/8	6
56	410-010	Washer, Flat #10	6
57	31-26183	Prox Switch	1
58	31-03008-1	Cable, Prox Switch	1
59	67-26151	Pen Holder/Adapter	1
60	Optional	See Chart	1
61	67-26151	Pen Holder/Adapter(Part of #59)	1
62	203-84	Nut, Hex #5-40	1
63	67-26187	Cover	1
64	409-99	Finish Washer, #10	4
65	333-102-8S	Screw, Button Hd. #10-32 x 1/2	4
66	67-26182	Tool Guard	1
67	54-26393	Shoulder Bolt	6
68	68-26045	Pen Lift Assembly, Double Acting (Pen Not Included)	1
69	91-26002-W	Decal, Eastman Logo	1
*70	67-26163	Ball Driver. 9/64", 7" Long	1
*71	67-26174	T-Handle, 9/64", 6" Long	1
*72	67-26175	Hex Key, 5/64"	1
*73	67-26176	Hex Key, 2.5 mm	1
74	67-26359	Back Cover, Optional	1
75	670-211	Pen/Marker Locking O'ring	1

* Not Shown

A/R - As Required

(B) 27-02996-2 Air Tubing, 5/32" A/R

Replacement Ink Pens		
Part No.	Description	Qty
67-26152	Black Ink pen	1
67-26152-1	Yellow Ink Pen	1
67-26152-2	Silver Ink Pen	1
67-26152-3	Ultraviolet Ink Pen	1
67-26152-4	Gold Ink Pen	1
67-26152-5	Green Ink Pen	1
67-26152-6	Black Bold Ink Pen	1

Replacement Ink Markers		
Part No.	Description	Qty
67-26286-2	Metalic Silver Marker	1
67-26286-4	Metalic Gold Marker	1
67-26339	Fine Black Marker	1
67-26339-5	Fine Red Marker	1
67-26340-6	Fine White Marker	1

Markers Require Adapter Kit #96-26050

Eastman®

Over a Century of Cutting Expertise

Rack & Rail Assembly

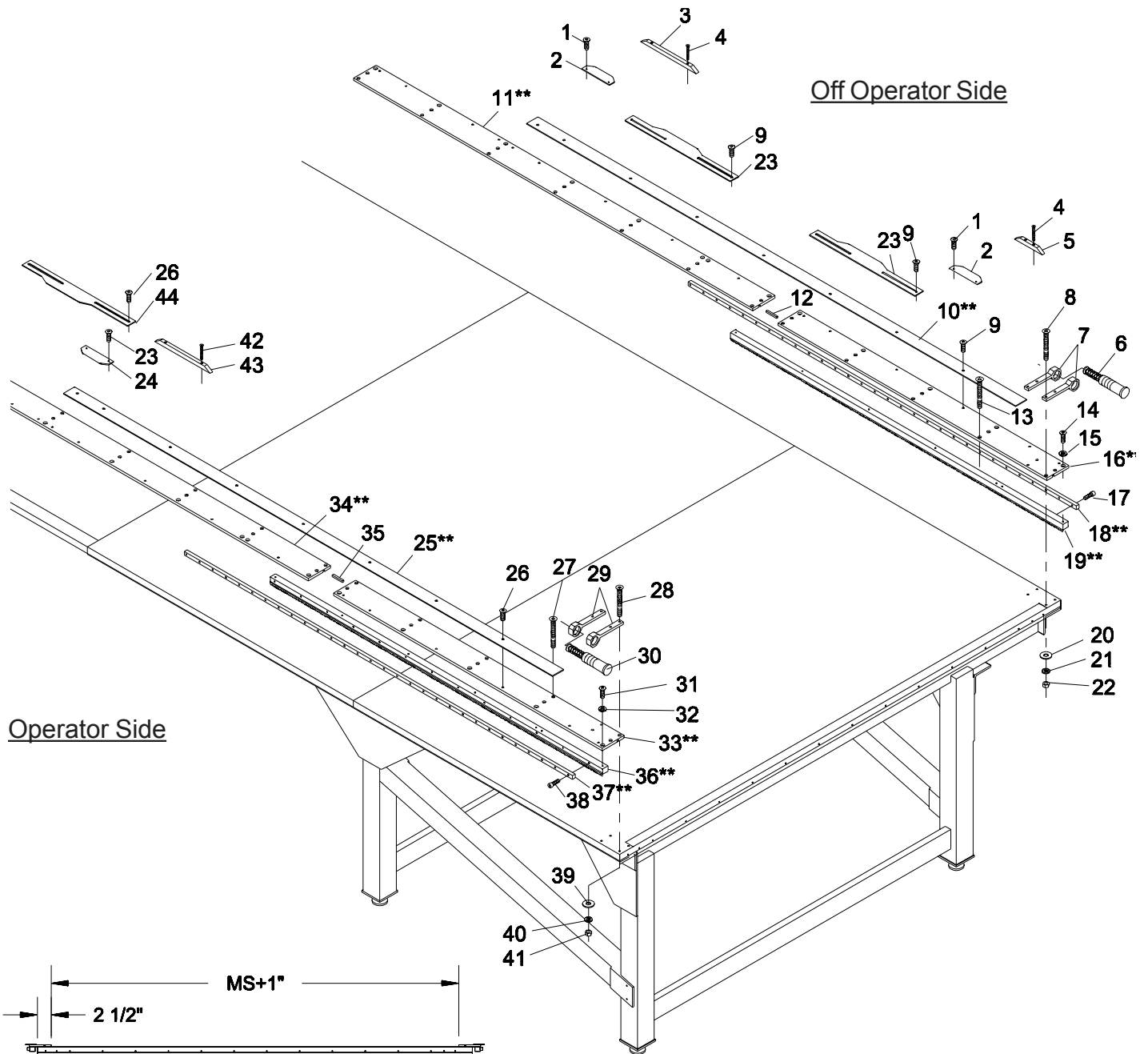

Operator Side

Off Operator Side

Note: ** Components sold in matched sets. Please consult factory before placing your order.

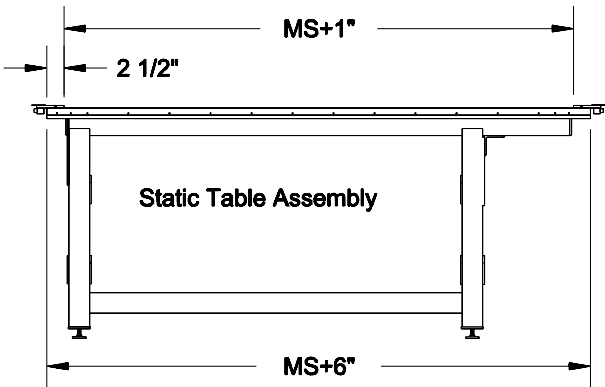

Rack & Rail Mounting Dimensions

Rack & Rail Assembly (Off Operator Side)

ITEM	PART No.	DESCRIPTION	QTY
1	333-93-6	Screw, Button Hd. #8-32 x 3/8	4
2	54-26077	Stop Cam, Side Activation	*2
3	54-T0412	Stop Cam, Long, Top Activation	*1
4	332-102-14	Screw, Flat Hd. #10-32 x 7/8	*4
5	54-T0413	Stop Cam, Short, Top Activation	*1
6	67-01051-2	Shock Absorber	2
7	54-T0179-5	Shock Mount	4
8	333-34-48	Screw, Button Hd. 1/4-20 x 3"	8
9	333-34-6	Screw, Button Hd. 1/4-20 x 3/8	A/R
10**	54-T0013-2	Dust Cover, 8'	A/R
	54-T0013-3	Dust Cover, 6'	A/R
	54-T0013-1	Dust Cover, 4'	A/R
11**	54-T0012-7	Rack Plate, 6'	A/R
12	603-8-8-14	Key, Square, 1/4 x 1/4 x 7/8	A/R
13	321-34-32	Screw, Flat Hd. 1/4-20 x 2"	A/R
14	333-102-8	Screw, Button Hd., #10-32 x 1/2	A/R
15	410-010	Washer, Flat #10	A/R
16**	54-T0012-2	Rack Plate, 4'	1
	54-T0012-1	Rack Plate, 8'	1
17	341-3-16	Screw, Socket Hd. M3 x 16	A/R
18**	67-12979-1	Bearing Rail, 63" Long	A/R
	54-26018	Bearing Rail, 18" Long	A/R
19**	54-00236-1	Gear Rack, 1' Long	1
	54-00236-2	Gear Rack, 71-15/16" Long	1
	54-00236-3	Gear Rack, 59-15/16" Long	1
	54-00236-4	Gear Rack, Additional 71-15/16" Long	A/R
20	410-34	Washer, Flat 1/4	A/R
21	402-34	Washer, Lock 1/4	A/R
22	203-34	Nut, 1/4-20	A/R
23	54-26077-2	Adjustable Stop Cam	*3

* - Not Required on Some Models
A/R- as Required
MS - Machine Size

Optional Grease Gun Adapter Tool for the linear bearings is not shown.
Part number 67-26124.

Note: ** Components sold in matched sets. Please consult factory before placing your order.

Rack & Rail Assembly (Operator Side)

ITEM	PART No.	DESCRIPTION	QTY
23	333-93-6	Screw, Button Hd. #8-32 x 3/8	4
24	54-26077	Stop Cam, Side Activation	*2
25**	54-T0013-2	Dust Cover, 8'	A/R
	54-T0013-3	Dust Cover, 6'	A/R
	54-T0013-1	Dust Cover, 4'	A/R
26	333-34-6	Screw, Button Hd. 1/4-20 x 3/8	A/R
27	321-34-32	Screw, Flat Hd. 1/4-20 x 2"	A/R
28	333-34-48	Screw, Button Hd. 1/4-20 x 3"	8
29	54-T0179-5	Shock Mount	4
30	67-01051-2	Shock Absorber	2
31	333-102-8	Screw, Button Hd., #10-32 x 1/2	A/R
32	410-010	Washer, Flat #10	A/R
33**	54-T0012-2	Rack Plate, 4'	1
	54-T0012-1	Rack Plate, 8'	1
34**	54-T0012-7	Rack Plate, 6'	A/R
35	603-8-8-14	Key, Square, 1/4 x 1/4 x 7/8	A/R
36**	54-00236-1	Gear Rack, 1' Long	1
	54-00236-2	Gear Rack, 71-15/16" Long	1
	54-00236-3	Gear Rack, 59-15/16" Long	1
	54-00236-4	Gear Rack, Additional 71-15/16" Long	A/R
37**	67-12979-1	Bearing Rail, 63" Long	A/R
	54-26018	Bearing Rail, 18" Long	A/R
38	341-3-16	Screw, Socket Hd. M3 x 16	A/R
39	410-34	Washer, Flat 1/4	A/R
40	402-34	Washer, Lock 1/4	A/R
41	203-34	Nut, 1/4-20	A/R
42	332-102-14	Screw, Flat Hd. #10-32 x 7/8	*2
43	54-T0412	Stop Cam, Long, Top Activation	*1
44	54-26077-2	Adjustable Stop Cam	*3

* - Not Required on Some Models
A/R- as Required
MS- Machine Size

Eastman®

Over a Century of Cutting Expertise

Static Table Assembly

96-260MS-TL

Porous Plastic Resurfacing Kit 96-26021-MSTL
Includes: Porous Plastic Sheets, Seam Sticks, and Super 77 Adhesive Spray.

MS= Machine Size TL =Table Length

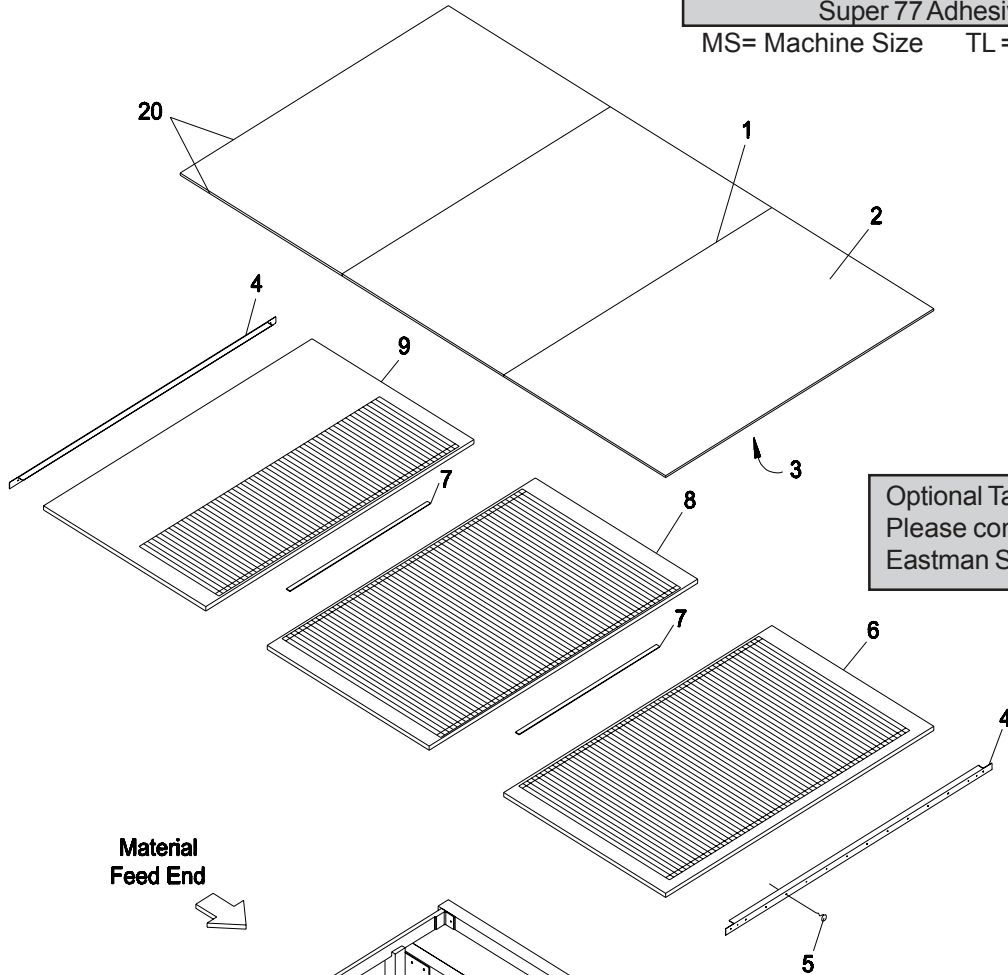

Optional Table Surfaces available.
Please consult factory or your nearest
Eastman Sales Representative.

Material
Feed End

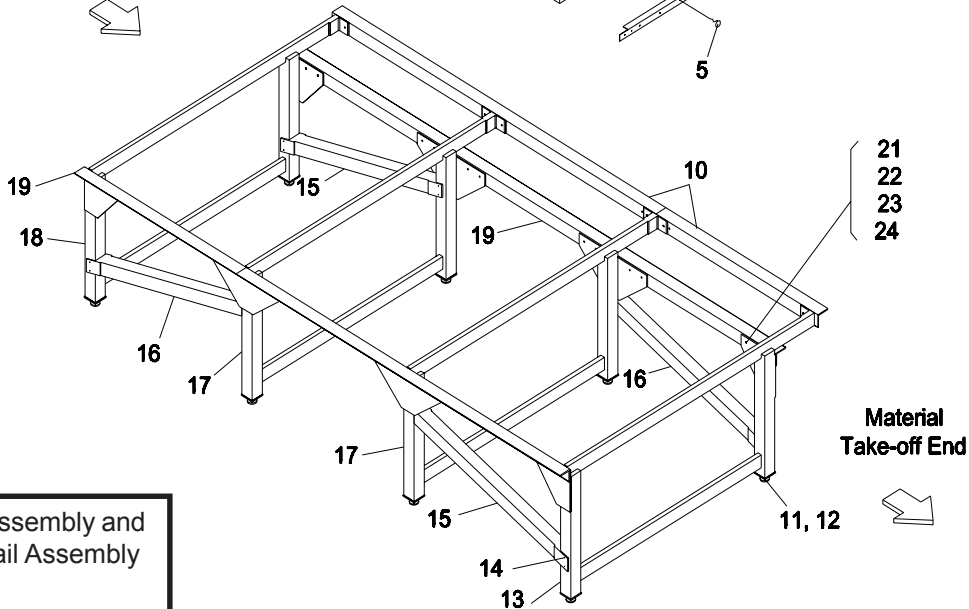

Material
Take-off End

Vacuum Assembly and
Rack & Rail Assembly
not shown

ITEM	PART No.	DESCRIPTION	QTY
1	67-26034	Plastic Seam Stick, 10"	A/R
2	54-02981	Porous Plastic Sheet, 43" x 79 1/2"	A/R
3	67-26036	S77 Adhesive Spray, Cutting Surface	A/R
	67-26036-1	S90 Adhesive Spray, Cutting Surfaces	A/R
4	54-26306-MS	Table End Cover	2
5	65-26022	Screw, #8 x 2" long	A/R
6	67-26028-MS	Table Section, Take-off End	1
7	54-26323-MS	Table Spline	A/R
8	67-26023-MS	Table Section, Center	A/R
9	67-26053-MS	Table Section, Feed End	1
10	54-26309	Top Angle, 4'	A/R
	54-26310	Top Angle, 8'	A/R
	54-26322	Top Angle, 12'	A/R
11	204-43	Stop Nut, 1/2-13	A/R
12	67-26237	Leg Leveler	A/R
13	54-26312-MS	End Table Legs, Take-off	1
14	373-99-12	Screw, Self Drill & Tap Type	24
15	54-26305-1	Angle Brace, Left	2
16	54-26305	Angle Brace, Right	2
17	54-26314-MS	Center Table Legs	A/R
18	54-26313-MS	End Table Legs, Feed End	1
19	54-26307	Front Angle Support, 4'	A/R
	54-26308	Front Angle Support, 8'	A/R
	54-26320	Front Angle Support, 12'	A/R
20	67-26256-1	Sealing Caulk, Clear, Tube	A/R
*	67-26256	Sealing Caulk, Clear, Pressurized Can	A/R
21	335-38-20	Screw, Hex Hd. 3/8-16 x 1	A/R
22	410-38	Washer, Flat 3/8	A/R
23	402-38	Washer, Lock 3/8	A/R
24	205-38	Nut, Hex 3/8-16	A/R

A/R- as Required
MS- Machine Size
TL - Table Length
* - Optional

Please specify machine size and table length when ordering parts.

Eastman®

Over a Century of Cutting Expertise

Vacuum Components

Optional 6" Zoning Blast Gates	
42-26032	Single Blast Gate, Manual
96-26056-1	78-102" Handle Extension
96-26056-2	24-66" Handle Extension
42-26041	Pneumatic Blast Gate Kit, 4 Gates
42-26041-1	Pneumatic Blast Gate Kit, 8 Gates
42-26041-2	Pneumatic Blast Gate Kit, 17 Gates
42-26041-3	Pneumatic Blast Gate Kit, 2 Gates

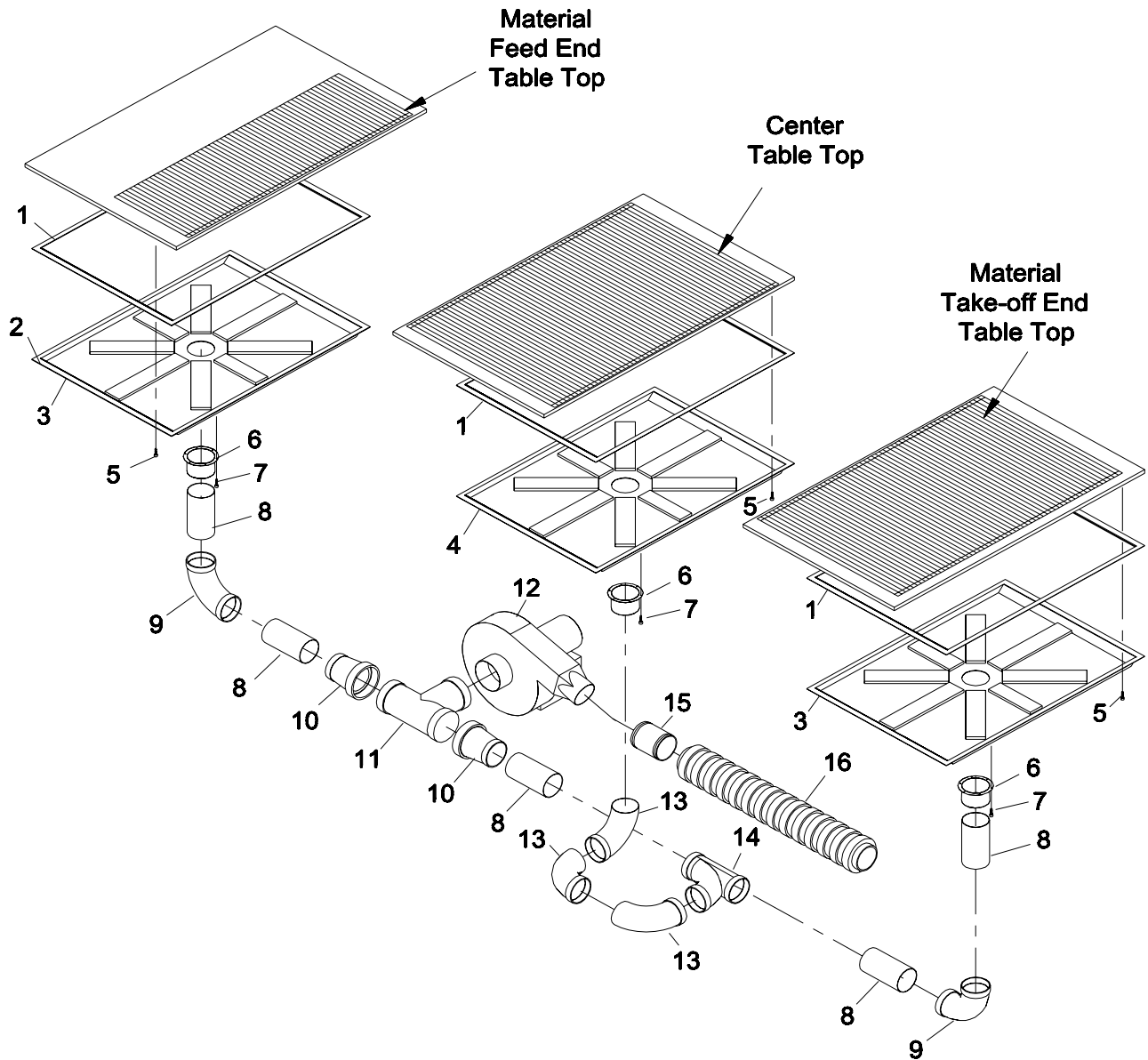

Plenum Grounding Kit
 96-26115 Static Eliminator Kit, Includes 16 Grounding Wires

ITEM	PART No.	DESCRIPTION	QTY
1	67-26225	Foam Bonding Tape, 72 Yard Roll	1
2	67-26256-1	Caulk Sealer, Tube	A/R
	67-26256	Caulk Sealer, Pressurized Can	A/R
3	67-26021-MS-E	Vacuum Plenum, End	2
4	67-26021-MS-C	Vacuum Plenum, Center	A/R
5	65-26008	Self Drill & Tap Type #8 x 1/2"	A/R
6	67-26290	Vacuum Top Hat	A/R
7	373-93-12	Self Drill & Tap Type #8 x 3/4"	A/R
8	42-26022	6" Vacuum Pipe, 12' Long	A/R
9	42-26017	6" x 90degree Vacuum Elbow	2
10	42-26036	6" - 8" Vacuum Reducer	2
11	42-26033	8" Vacuum Tee	1
12	42-26023	7.5hp Blower, 220v/60/3ph	A/R
13	42-26038	6" x 90degree Swept Vacuum Elbow	3
14	42-26034	6" Vacuum Tee	A/R
15	42-26028	6" Rubber Vacuum Coupling	1
16	42-26006-60	6" x 60" Long Vacuum Muffler	1

A/R - As Required
MS- Machine Size

Note:

-Vacuum Components may vary for optional table sizes.

-Optional Vacuum Blowers available. Please consult Factory or your nearest Eastman Sales Representative.

-Some materials may require Plastic Overlay (#42-26037-MS) to assist material hold down when cutting. Test cuts maybe required to determine actual vacuum holding power.

E-Box Assembly 31-B4001

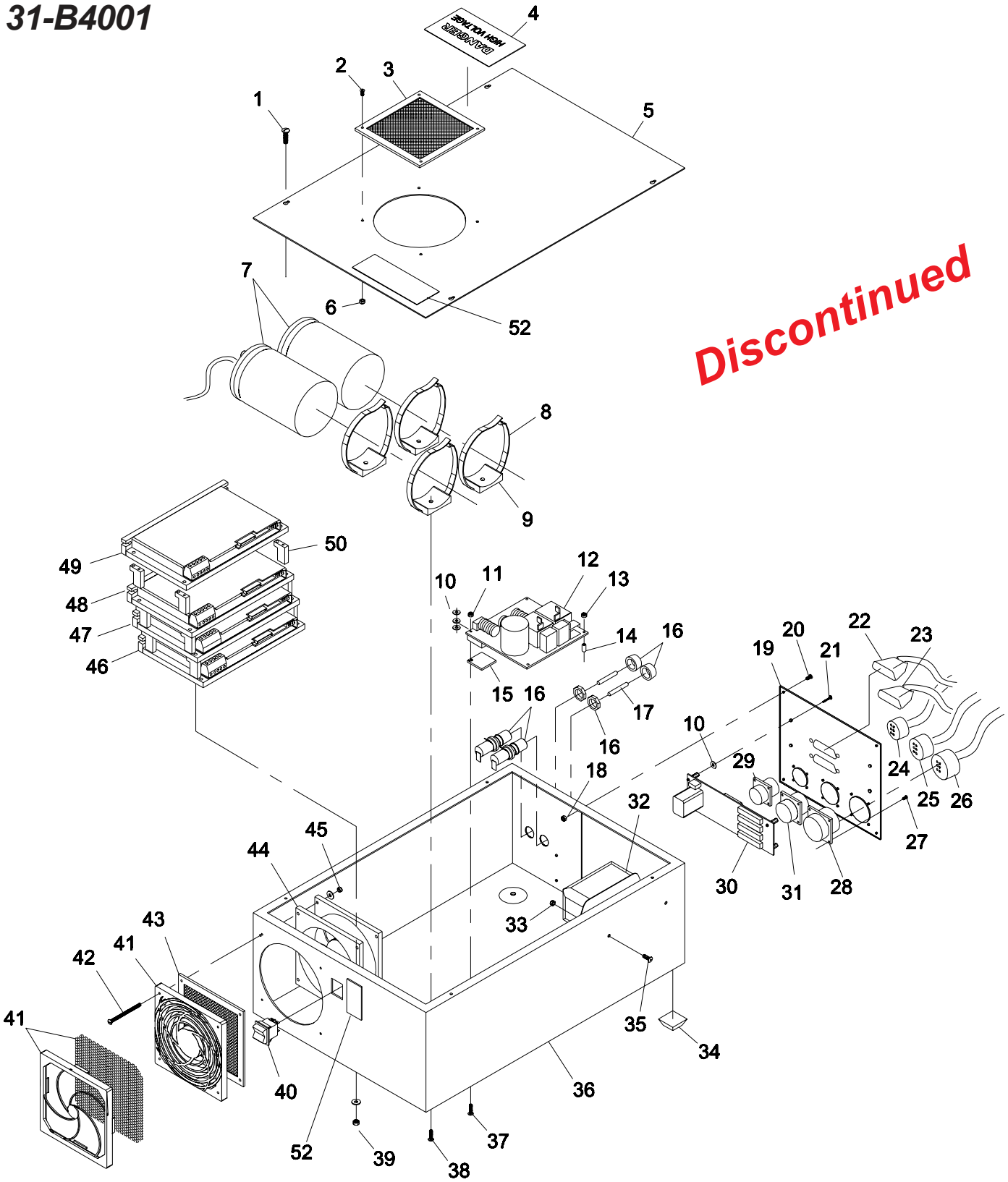

Discontinued

ITEM	PART No.	DESCRIPTION	QTY
1	—	Screw, Supplied With E-Box	4
2	333-93-6	Screw, Button Hd. #8-32 x 3/8	4
3	31-03117	Filter	1
4	91-03001	Decal, "Danger"	1
5	54-26007	E-Box, Machined	1
6	211-93	Stop Nut, Hex #8-32	4
7	31-00730-1	Capacitor	2
8	11-975-15	Cable Tie, 15"	4
9	54-C0398	Capacitor Mount	4
10	410-060	Washer, Flat #6	7
11	203-86	Nut, Hex #6-32	2
12	10-00902-2	E-Box, Power Supply	1
13	203-86	Nut, Hex #6-32	2
14	11-1975	Standoff	2
15	31-26049	Heat Sink Pad	2
16	31-00741	Fuse Holder	2
17	31-03118	Fuse, 15 amp	2
18	211-93	Stop Nut, Hex #8-32	4
19	54-E2105	Plate, Back	1
20	333-93-6	Screw, Button Hd. #8-32 x 3/8	4
21	320-86-10	Screw, Pan Hd. #6-32 x 5/8	4
22	31-B1021-10	Cable Assembly, I/O Dual X	1
23	31-B1016-TL	Cable Assembly, Hall Effect	1
24	31-B1013-25	Cable Ass'y, AC Power E-Box	1
25	31-B1019-TL	Cable Ass'y, Y & Z Motor	1
26	31-B1022-TL	Cable Ass'y, X1 & X2 Motor	1
27	333-86-4	Screw, Button Hd. #6-32 x 1/4	12
28	31-B3012	E- Box Wire Harness, X1 & X2 Motor	1
29	31-B3009	E-Box Wire Harness, AC Power	1

ITEM	PART No.	DESCRIPTION	QTY
30	10-00901-2	I/O Amp Board	1
31	31-B3011	Y & Z Motor Harness	1
32	31-00710-3	Filter, EMI	1
33	211-93	Stop Nut, Hex #8-32	2
34	67-03003	Rubber Foot	4
35	333-93-6	Screw, Button Hd. #8-32 x 3/8	2
36	54-26007	E-Box, Machined	1
37	320-86-10	Screw, Pan Hd. #6-32 x 5/8	4
38	318-102-6	Screw, Pan Hd. #10-32 x 3/8	8
39	211-86	Stop Nut, Hex #6-32	4
40	580C1-188	Switch	1
41	31-03103	Fan Filter/Guard	1
42	313-86-32	Screw, Rnd. Hd. #6-32 x 2	4
43	31-03117	Filter	1
44	11-1908	Fan	1
45	203-86	Nut, Hex #6-32	4
46	31-03012-2	X1-Motor Servo Amp	1
	31-B1001-1	X1 Amp Cable	1
47	31-03012-2	X2-Motor Servo Amp	1
	31-B1001-2	X2 Amp Cable	1
48	31-03012-2	Y-Motor Servo Amp	1
	31-B1002	Y Amp Cable	1
49	31-03012-2	Z-Motor Servo Amp	1
	31-B1003	Z Amp Cable	1
50	54-C0385	Amp Spacer	12
51	91-26017	E-box Decal Sheet, Complete	1
52	91-26018	115 Volt Decal	1

* Not included in assembly
TL - Table Length

Eastman®

Over a Century of Cutting Expertise

Optional: Heavy Duty Tool Head Assembly, 1" H9299-1HD

Refer to
Automated Cutting Tools Manual
E-515 for latest Available Tools

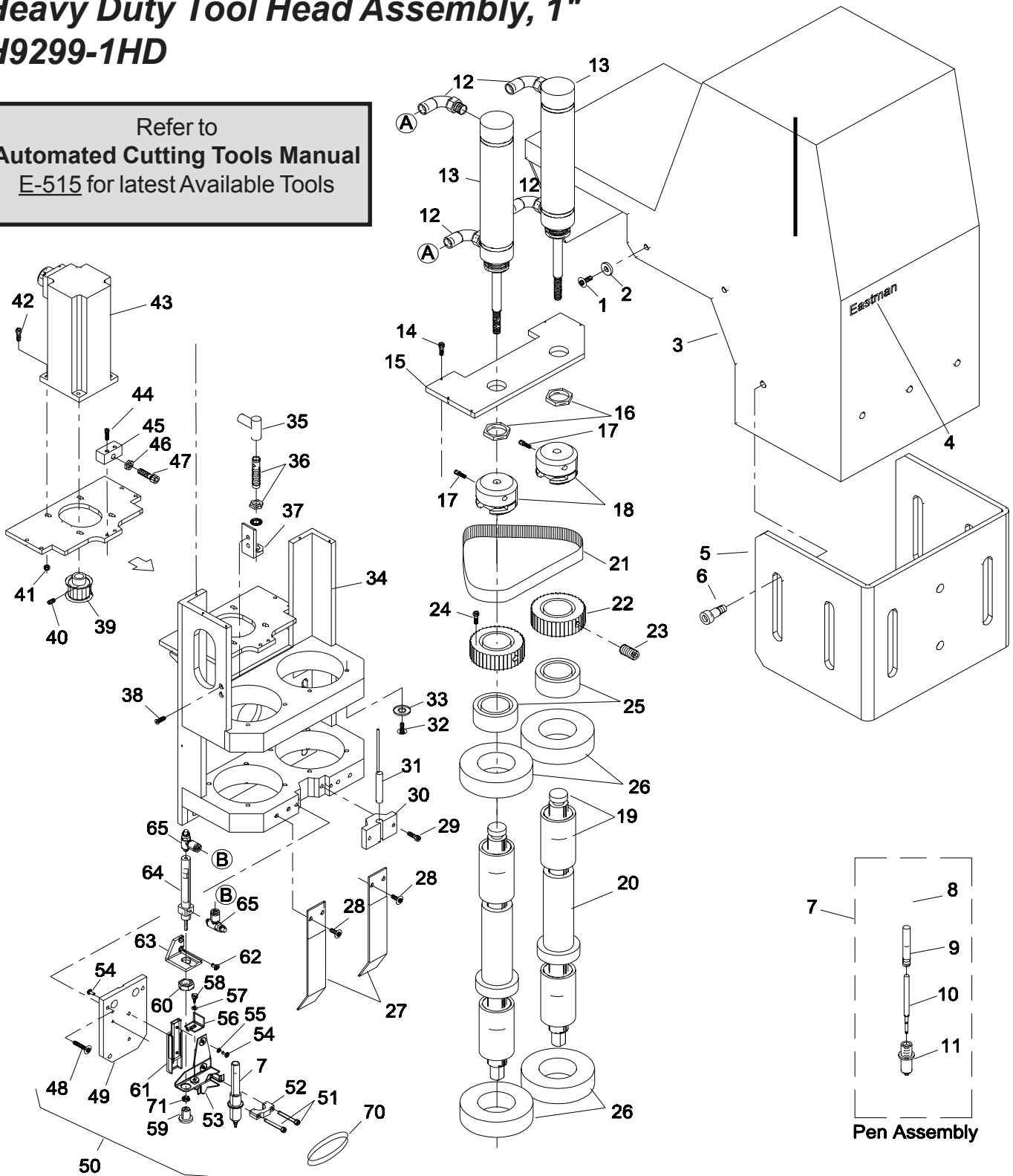

* Sharpie Adapter Kit #96-26050

ITEM	PART No.	DESCRIPTION	QTY
1	333-102-8S	Screw, Button Hd. #10-32 x 1/2	4
2	409-99	Finish Washer, #10	4
3	67-26147	Cover	1
4	91-26002-W	Decal, Eastman Logo	1
5	67-26182	Tool Guard	1
6	54-26393	Shoulder Bolt	5
7	68-26027	Pen Assembly	1
8	67-26150	Grip Tube	1
9	67-26151	Pen Holder/Adapter	1
10	Optional	See Chart	1
11	67-26151	Pen Holder/Adapter (part of #9)	1
12	100-13-7	Swivel Elbow, 1/8 npt x 1/4	4
13	54-26326	Air Cylinder, Special	2
14	335-102-6	Screw, Socket Hd. #10-32x 3/8	5
15	54-26123	Cylinder Mounting Plate	1
16	54-26152	Jam Nut	2
17	335-102-10	Screw, Socket Hd. #10-32x 5/8	2
18	54-26116	Coupling	2
19	54-26119	Linear Shaft and Bearings Set	2
20	54-26120	Bearing Spacer	2
21	67-26083	Belt, 5m085 150	1
22	54-26094	Drive Pulley	2
23	345-34-8	Setscrew, 1/4-20 x 1/2	2
24	335-34-8	Screw, Socket Hd. 1/4-20x 1/2	1
25	54-26093	Pulley Spacer	2
26	67-26082	Bearing	4
27	54-26117	Curtain Guard	2
28	333-102-8	Screw, Button Hd #10-32 x 1/2	4
29	333-93-8	Screw, Button Hd. #8-32 x 1/2	2
30	54-H0403	Mount, Laser Pointer	1
31	81-00002	Laser Pointer	1
32	333-102-8	Screw, Button Hd #10-32 x 1/2	8
33	410-010	Washer, Flat #10	8
34	54-26118	H9299-1HD Tool Head Frame	1
35	31-03008-1	Sensor Cable	1

ITEM	PART No.	DESCRIPTION	QTY
36	31-03008	Prox Sensor	1
37	54-26095	Mount, Prox Sensor	1
38	332-35-16	Screw, Flat Hd. 1/4-28 x 1"	2
39	67-26081	Motor Pulley	1
40	345-93-4	Setscrew, #8-32 x 1/4	2
41	211-93	Stop Nut, #8-32	4
42	335-93-12	Screw, Socket Hd #8-32 x 3/4	4
43	31-S3205-1	Z-Motor, Servo w/Connector	1
44	335-102-16	Screw, Socket Hd. #10-32 x 1"	2
45	54-26179	Tensioner Block	1
46	203-34	Hex Nut, 1/4-20	1
47	335-34-20	Screw, Socket 1/4-20 x 1 1/2	1
48	333-102-8	Screw, Button Hd #10-32 x 1/2	4
49	54-26185-2	Mounting Plate, Pen Holder	1
50	68-26045-3	Pen Lift Assembly	1
51	335-86-16	Screw, Socket Hd. #6-32 x 1	2
52	54-H0213	Pen Holder	1
53	54-26272	Pen Mounting Bracket	1
54	333-3-6	Screw, Button Hd. 3m x 6m	4
55	402-040	Washer, Lock #4	2
56	54-26269	Slide Lock	1
57	67-03004	O-Ring	1
58	355-2-2	Shoulder Bolt, 1/8 x 1/8	1
59	54-26270	Cylinder End	1
60	67-26224	Cylinder Nut	2
61	67-26223	Pen Mount Slide Bearing	1
62	333-86-4	Screw, Button Hd. #6-32 x 1/4	2
63	54-26273	Cylinder Mounting Bracket	1
64	67-26224	Pen Cylinder	1
65	100-18-19	Flow Control Fitting	2
*66	67-26163	Ball Driver. 9/64", 7" Long	1
*67	67-26174	T-Handle, 9/64", 6" Long	1
*68	67-26175	Hex Key, 5/64"	1
*69	67-26176	Hex Key, 2.5 mm	1
70	670-211	Pen/Marker Locking O'ring	1
71	203-84	Nut, Hex #5-40	1

* Not Shown

A/R - As Required

(A) 27-02996-1 Air Tubing, 1/4" A/R

(B) 27-02996-2 Air Tubing, 5/32" A/R

Replacement Ink Pens		
Part No.	Description	Qty
67-26152	Black Ink pen	1
67-26152-1	Yellow Ink Pen	1
67-26152-2	Silver Ink Pen	1
67-26152-3	Ultraviolet Ink Pen	1
67-26152-4	Gold Ink Pen	1
67-26152-5	Green Ink Pen	1
67-26152-6	Black Bold Ink Pen	1

Replacement Ink Markers		
Part No.	Description	Qty
67-26286-2	Metalic Silver Marker	1
67-26286-4	Metalic Gold Marker	1
67-26339	Fine Black Marker	1
67-26339-5	Fine Red Marker	1
67-26340-6	Fine White Marker	1

Markers Require Adapter Kit #96-26050

Eastman®

Over a Century of Cutting Expertise

**Optional:
Fiber Tool Head Assembly
H9299-2FC**

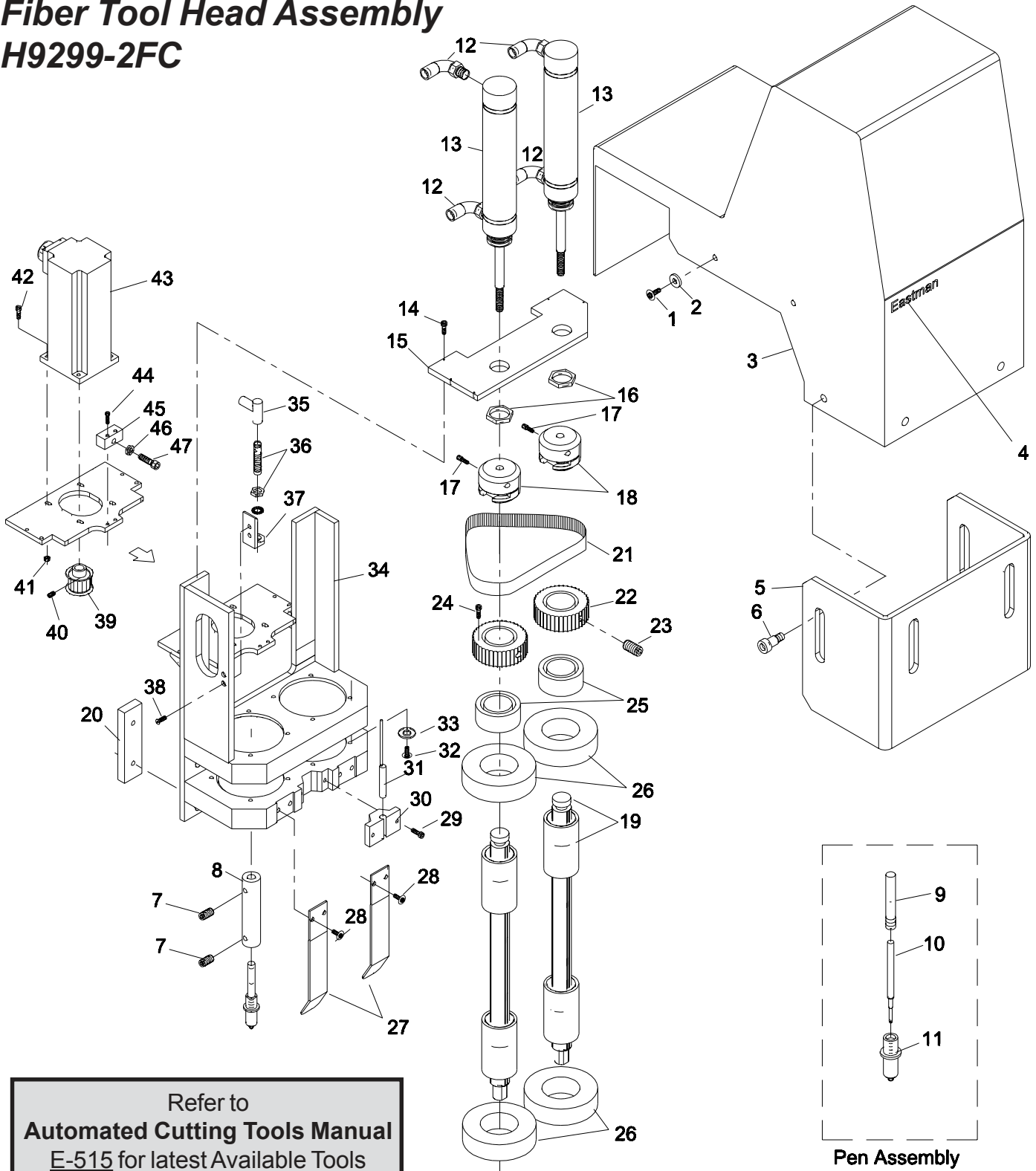

ITEM	PART No.	DESCRIPTION	QTY
1	333-102-8S	Screw, Button Hd. #10-32 x 1/2	4
2	409-99	Finish Washer, #10	4
3	67-26126	Cover, Fiber Head	1
4	91-26002-W	Decal, Eastman Logo	1
5	67-26149	Tool Guard	1
6	54-26393	Shoulder Bolt	6
7	331-34-10	Hex Screw, 1/4-20	1
	387-34-12	Thumb Screw, 1/4-20	1
8	54-26082	Pen Adapter	1
9	67-26151	Pen Holder/Adapter	1
10	Optional	See Chart	1
11	67-26151	Pen Holder/Adapter (part of #9)	1
12	100-13-7	Swivel Elbow, 1/8 npt x 1/4	4
13	54-26151	Air Cylinder, Special	2
14	335-102-6	Screw, Socket Hd. #10-32x 3/8	5
15	54-26123	Cylinder Mounting Plate	1
16	54-26152	Jam Nut	2
17	335-102-10	Screw, Socket Hd. #10-32x 5/8	2
18	54-26088	Coupling	2
19	54-26092	Linear Shaft and Bearings Set	2
20	54-26115	Tool Head Offset Spacer	2
21	67-26083	Belt, 5m085 150	1
22	54-26094	Drive Pulley	2
23	345-34-8	Setscrew, 1/4-20 x 1/2	2
24	335-34-8	Screw, Socket Hd. 1/4-20x 1/2	1
25	54-26093	Pulley Spacer	2
26	67-26082	Bearing	4
27	54-26089	Curtain Guard	2
28	333-102-8	Screw, Button Hd #10-32 x 1/2	4
29	333-93-8	Screw, Button Hd. #8-32 x 1/2	2

ITEM	PART No.	DESCRIPTION	QTY
30	54-H0403	Mount, Laser Pointer	1
31	81-00002	Laser Pointer	1
32	333-102-8	Screw, Button Hd #10-32 x 1/2	8
33	410-010	Washer, Flat #10	8
34	54-26090	H9299-2FC Tool Head Frame	1
35	31-03008-1	Sensor Cable	1
36	31-03008	Prox Sensor	1
37	54-26095	Mount, Prox Sensor	1
38	332-35-16	Screw, Flat Hd. 1/4-28 x 1"	2
39	67-26081	Motor Pulley	1
40	345-93-4	Setscrew, #8-32 x 1/4	2
41	211-93	Stop Nut, #8-32	4
42	335-93-12	Screw, Socket Hd #8-32 x 3/4	4
43	31-S3205-1	Z-Motor, Servo w/Connector	1
44	335-102-16	Screw, Socket Hd. #10-32 x 1"	2
45	54-26179	Tensioner Block	1
46	203-34	Hex Nut, 1/4-20	1
47	335-34-20	Screw, Socket 1/4-20 x 1 1/2	1
*48	67-26163	Ball Driver. 9/64", 7" Long	1
*49	67-26174	T-Handle, 9/64", 6" Long	1
*50	67-26175	Hex Key, 5/64"	1
*51	67-26176	Hex Key, 2.5 mm	1

* Not Shown
A/R - As Required

(A)	27-02996-1	Air Tubing, 1/4"	A/R
-----	------------	------------------	-----

Replacement Ink Pens		
Part No.	Description	Qty
67-26152	Black Ink pen	1
67-26152-1	Yellow Ink Pen	1
67-26152-2	Silver Ink Pen	1
67-26152-3	Ultraviolet Ink Pen	1
67-26152-4	Gold Ink Pen	1
67-26152-5	Green Ink Pen	1
67-26152-6	Black Bold Ink Pen	1

Replacement Ink Markers		
Part No.	Description	Qty
67-26286-2	Metalic Silver Marker	1
67-26286-4	Metalic Gold Marker	1
67-26339	Fine Black Marker	1
67-26339-5	Fine Red Marker	1
67-26340-6	Fine White Marker	1

Eastman®

Over a Century of Cutting Expertise

**Optional:
Static Table
Diagnostic Control Cabinet**

31-S3285 (110v)

31-S3285-1 (220v/1ph)

Refer to
M9000 Instruction and Service Manual
E-509 for Wiring Diagrams

Option: not shown
Pressure Cabinet Enclosure Kit
96-26128

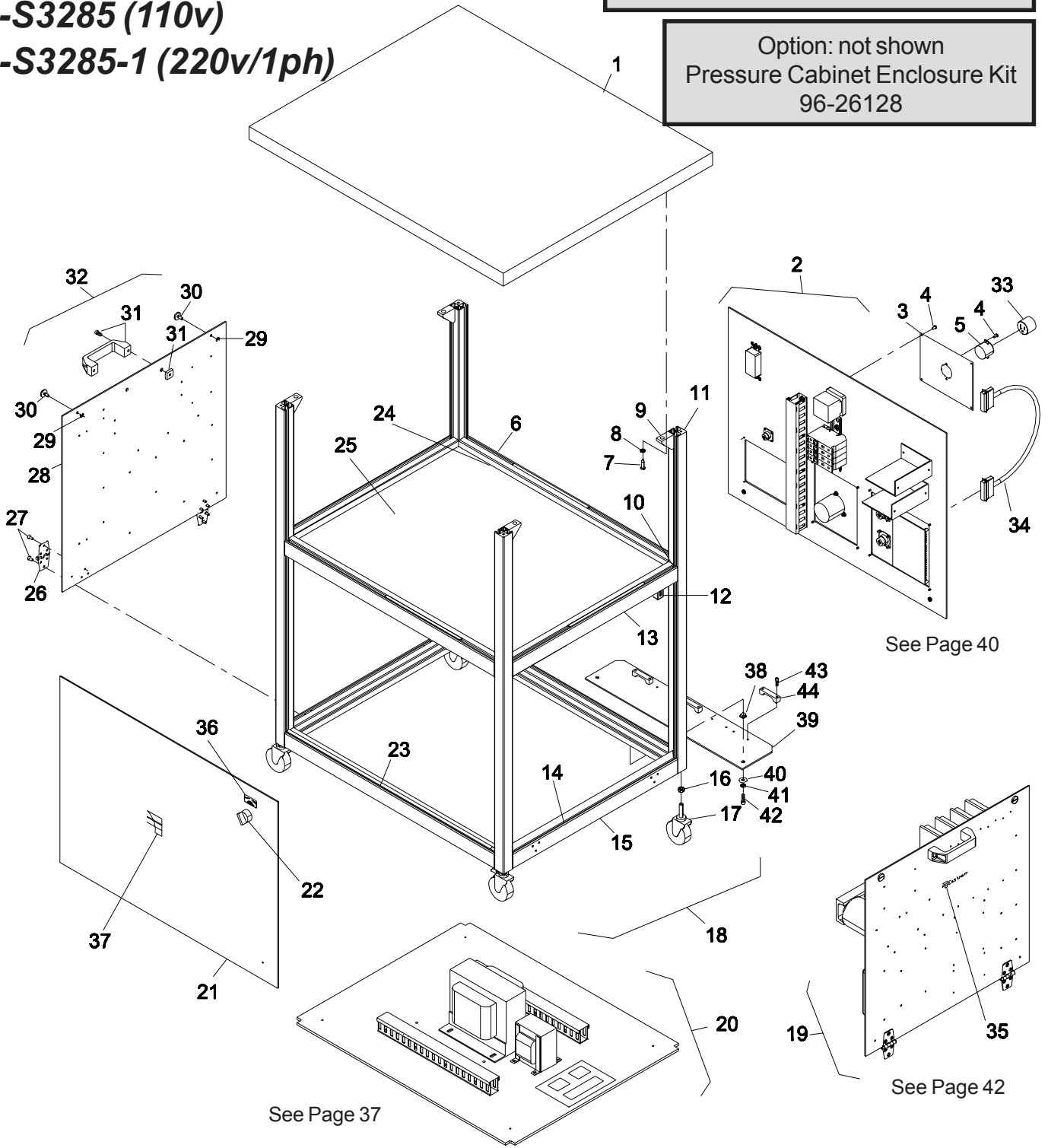

ITEM	PART No.	DESCRIPTION	QTY
1	54-26504	Cabinet Top	1
2	68-26096-1	Rear Panel Assembly (110v)	1
	68-26096-4	Rear Panel Assembly (220v/1ph)	1
3	54-26540-1	Connector Panel, Static	1
4	333-93-6	Screw, #8-32 x 3/8	6
5	31-26322	Power Outlet	1
6	54-26499-28	28" Cross Member	4
7	368-14-16	Self Tap Pan HD. #14	4
8	402-34	Washer, Lock 1/4	4
9	67-26380	Angle Mounting Bracket	4
10	67-26382	Panel Fastener	16
11	54-26509-39	36" Up-right Member	4
12	67-26377	Door Fastening Block	4
13	54-26499-22	22" Cross Member	2
14	67-26379	Sealing Lip, Door	15
15	54-26538	Hinge Cross Member	2
16	206-38	Nux, Hex 3/8	4
17	67-26384	Swivel Caster	4
18	68-26108	Frame Assembly, Cabinet	1
19	68-26094	Static Gantry E-Plate Assembly	1
20	68-26105-1	Bottom Panel Assembly	1
21	54-26508	Front Panel, Static	1

ITEM	PART No.	DESCRIPTION	QTY
22	31-26331	Switch, Green Selector	1
23	67-26378	Panel Seal	35
24	67-26381	Panel Side Cover	3
25	54-26510	Top Panel, Static	1
26	67-26375	Hinge, Door	2
27	332-102-8S	Flat Hd. #10-32 x 1/2	12
28	54-26506	Door Panel	1
29	662-14	Retaining Clip	2
30	67-26385	Door Lock Screw	2
31	67-26376	Door Handle	1
32	68-26095-1	E-Plate Assembly	1
33	11-1784	Connector, Twist Lock 120v	1
34	31-S3309	Cable, I/O	1
35	91-26002-W	Decal, Small Logo	2
36	91-26033	Decal Sheet, Complete Set	1
37	91-26005-W	Decal, Large Logo	1
38	65-26035	Nut, Special	3
39	54-26876	Strain Relief Bracket	1
40	410-36	Washer, Flat 5/16	3
41	402-36	Washer, Lock 5/16	3
42	65-26036-16	Socket Hd. Bolt, (metric)	3
43	335-102-12	Screw, Socket Hd. #10-32 x 3/4	6
44	54-C0320-2	Cable Clamp	3

Bottom Panel Assembly 68-26105-1

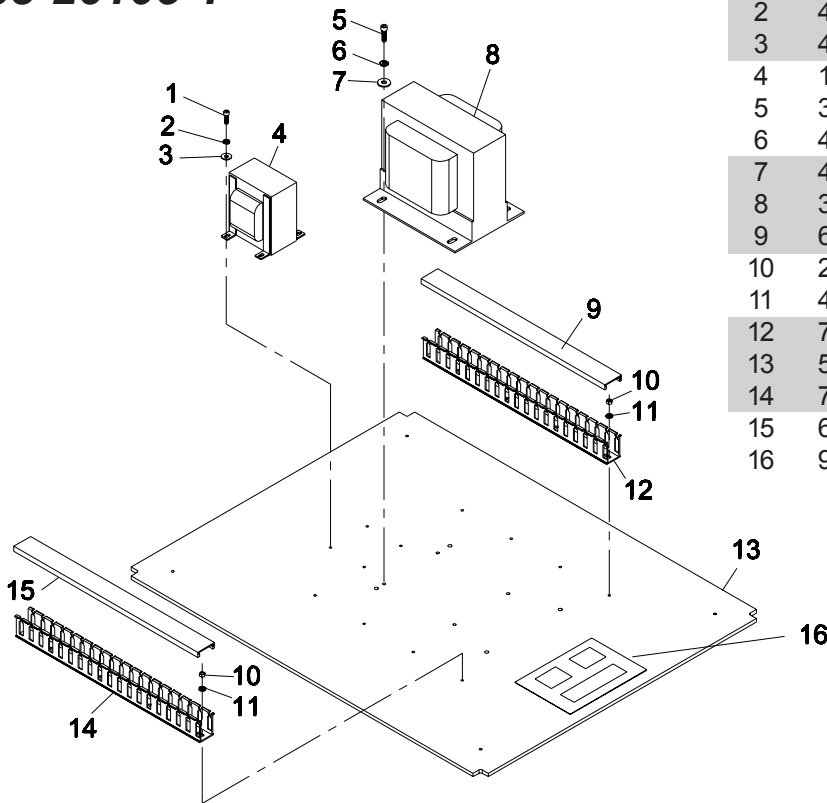

ITEM	PART No.	DESCRIPTION	QTY
1	335-102-8	Screw, Socket Hd. #10-32 x 1/2	4
2	402-102	Wahser, Lock #10	4
3	410-010	Washer, Flat #10	4
4	11-1620	Transformer, 24 volt	1
5	335-34-10	Screw, Socket Hd. 1/4-20 x 5/8	4
6	402-34	Wahser, Lock 1/4	4
7	410-34	Washer, Flat 1/4	4
8	31-26273	Transformer	1
9	67-02634	Conduit Top, 14" Long	1
10	203-93	Nut, Hex #8-32	8
11	402-080	Washer, Lock #8-	8
12	70-26001	Conduit Duct, 14" Long	1
13	54-26509	Bottom Panel	1
14	70-26001	Conduit Duct, 18" Long	1
15	67-02634	Conduit Top, 18" Long	1
16	91-26040	Decal, Transformer Wiring	1

Eastman®

Over a Century of Cutting Expertise

Rear Panel Assembly, Static
68-26096-1 (110v)
68-26096-4 (220v/1ph)

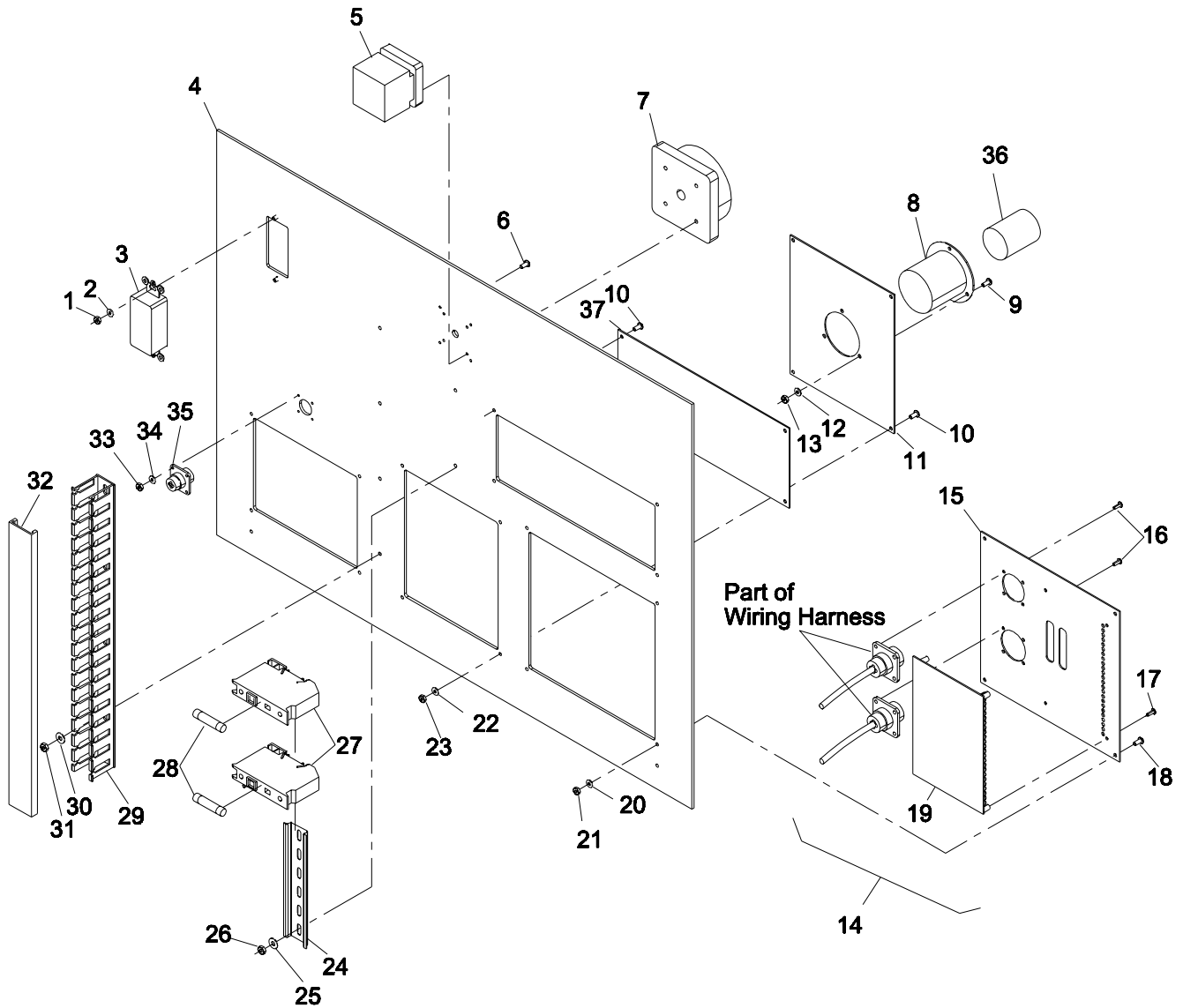

ITEM	PART No.	DESCRIPTION	QTY
1	203-86	Nut, Hex #6-32	2
2	402-060	Washer, Lock #6	2
3	31-26295	Power Outlet	1
4	54-26507	Rear Panel, Static	1
5	31-26296	Disconnect Switch,	1
6	333-86-6	Screw, Button Hd. #6-32 x 3/8	4
7	31-26297	Legend Plate, Disconnect Switch	1
8	11-1785	Inlet, Twist Lock (110 volt only)	1
	11-4784	Inlet, Twist Lock (220v/1ph only)	1
9	333-93-6	Screw, Button Hd. #8-32 x 3/8	3
10	333-93-6	Screw, #8-32 x 3/8	8
11	54-26537-1	Single Phase Panel	1
12	402-080	Washer, Lock #8-32	3
13	203-93	Nut, Hex #8-32	3
14	-		
15	54-26536	Gantry Connector Panel	1*
16	333-86-4	Screw, Button Hd. #6-32 x 1/4	8*
17	305C8-1	Screw, Pan Hd. #4-40 x 1/4	4*
18	333-93-6	Screw, #8-32 x 3/8	4
19	10-26061	Amp I/O Gantry Board with LED	1*
20	402-080	Washer, Lock #8-32	4
21	203-93	Nut, Hex #8-32	4
22	402-080	Washer, Lock #8-32	4
23	203-93	Nut, Hex #8-32	4
24	31-00739	Din Rail, 7" Long	1
25	402-080	Washer, Lock #8-32	2
26	203-93	Nut, Hex #8-32	2
27	31-26226	Fuse Block, wbf Style	1
28	31-26356-20	Fuse, 20 Amp. (110v/1ph only)	A/R
	31-26356-10	Fuse, 10 Amp. (220v/1ph only)	A/R
	31-26398	Circuit Breaker, 15 Amp	A/R
	31-26404	Circuit Breaker, 10 Amp	A/R
28A	31-26013-8	Fuse, 4 Amp	A/R
29	70-26001	Conduit Duct, 14" Long	1
30	402-080	Washer, Lock #8-32	4
31	203-93	Nut, Hex #8-32	4
32	67-02634	Conduit Top, 14" Long	1
33	203-86	Nut, Hex #6-32	2
34	402-060	Washer, Lock #6	2
35	11-4737	Connector, 4-pin	1
36	11-1784	Inlet Plug (110 v only)	1
	11-4785	Inlet Plug, (220v/1ph only)	1
37	54-26875	Auxiliary Panel	1

* - not included in assembly.

A/R - as Required

Eastman®

Over a Century of Cutting Expertise

Static Gantry E-Plate Assembly 68-26094

Panel Cables (Not Shown)	
31-S3311	Amp I/O Cable Assemble
31-S3299	Filter to Amp Cable
31-S3306	Transformer to Gantry Cable
31-S3308	Contact to Filter Cable
31-S3310	Capacitor to Amp Cable
31-S3293	Amp I/O to Power Supply
31-S3294	X1 & X2 Motor Power
31-S3295	Y & Z Motor Power
31-S3296	Gantry Fan Power
31-S3297	Gantry Power

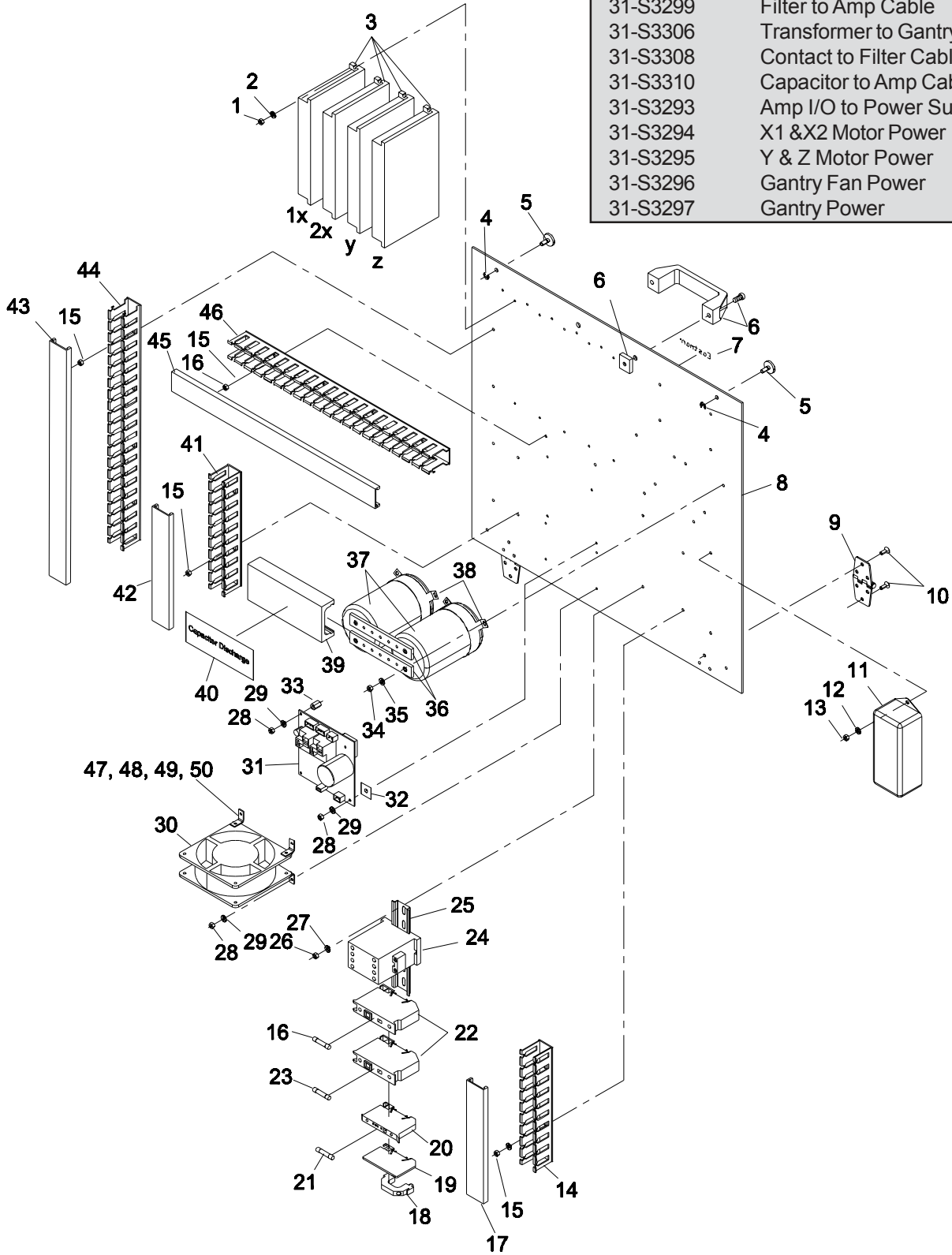

ITEM	PART No.	DESCRIPTION	QTY
1	203-86	Nut, Hex #6-32	8
2	402-060	Washer, Lock #6	8
3	31-03012-2	Servo Amplifier	4
4	662-14	Retaining Clip	2
5	67-26385	Door Lock Screw	2
6	67-26376	Door Handle	1
7	91-26002-W	Decal, Small Logo (not Included)	1
8	54-26505	Door Panel, Gantry Static	1
9	67-26375	Hinge, Door	2
10	332-102-8S	Flat Hd. #10-32 x 1/2	12
11	31-26252	Filter, 12 Amp	1
12	402-080	Washer, Lock #8-32	2
13	203-93	Nut, Hex #8-32	2
14	70-26001	Conduit Duct, 7" Long	1
15	211-93	Nut, Hex #8-32	12
16	31-26013-7	Fuse, 10 Amp.	1
17	67-02634	Conduit Top, 7" Long	1
18	31-26227	End Anchor, Din Rail	1
19	31-26225	End Barrier, Insulation	1
20	31-26224	Fuse Block, H4 Style	1
21	11-1300	Fuse, 1 Amp.	1
22	31-26226	Fuse Block, wbf Style	2
23	31-26356-1.5	Fuse, 1.5 Amp.	1
24	31-26298	Contactor, 24 Volt	1
25	31-00739	Din Rail, 7" Long	1
26	203-93	Nut, Hex #8-32	2
27	402-080	Washer, Lock #8-32	2
28	203-86	Nut, Hex #6-32	4
29	402-060	Washer, Lock #8	4
30	11-1908	Fan, Circulation	1
31	10-00902-2	Power Supply	1
32	31-26049	Heat Sink Pad	2
33	65-26007	Standoff, #6-32 x .31	2
34	203-93	Nut, Hex #8-32	3
35	402-080	Washer, Lock #8-32	3
36	54-26397-1	Bus Bar, Capacitor	2
37	31-00730-1	Capacitor, High Voltage	2
38	31-26272	Mounting Rings, Capacitor	2
39	54-26545	Capacitor Cover	1
40	91-26038	Decal, Capacitor Discharge	1
41	70-26001	Conduit Duct, 7" Long	1
42	67-02634	Conduit Top, 7" Long	1
43	67-02634	Conduit Top, 16" Long	1
44	70-26001	Conduit Duct, 16" Long	1
45	67-02634	Conduit Top, 15" Long	1
46	70-26001	Conduit Duct, 15" Long	1
47	67-26383	Fan Mount	4
48	313-86-6	Screw, Round Hd. #6-32 x 3/8	4
49	402-060	Washer, Lock #6	4
50	203-86	Nut, Hex #6	4

Easi Pull Assembly 67-26091-MS

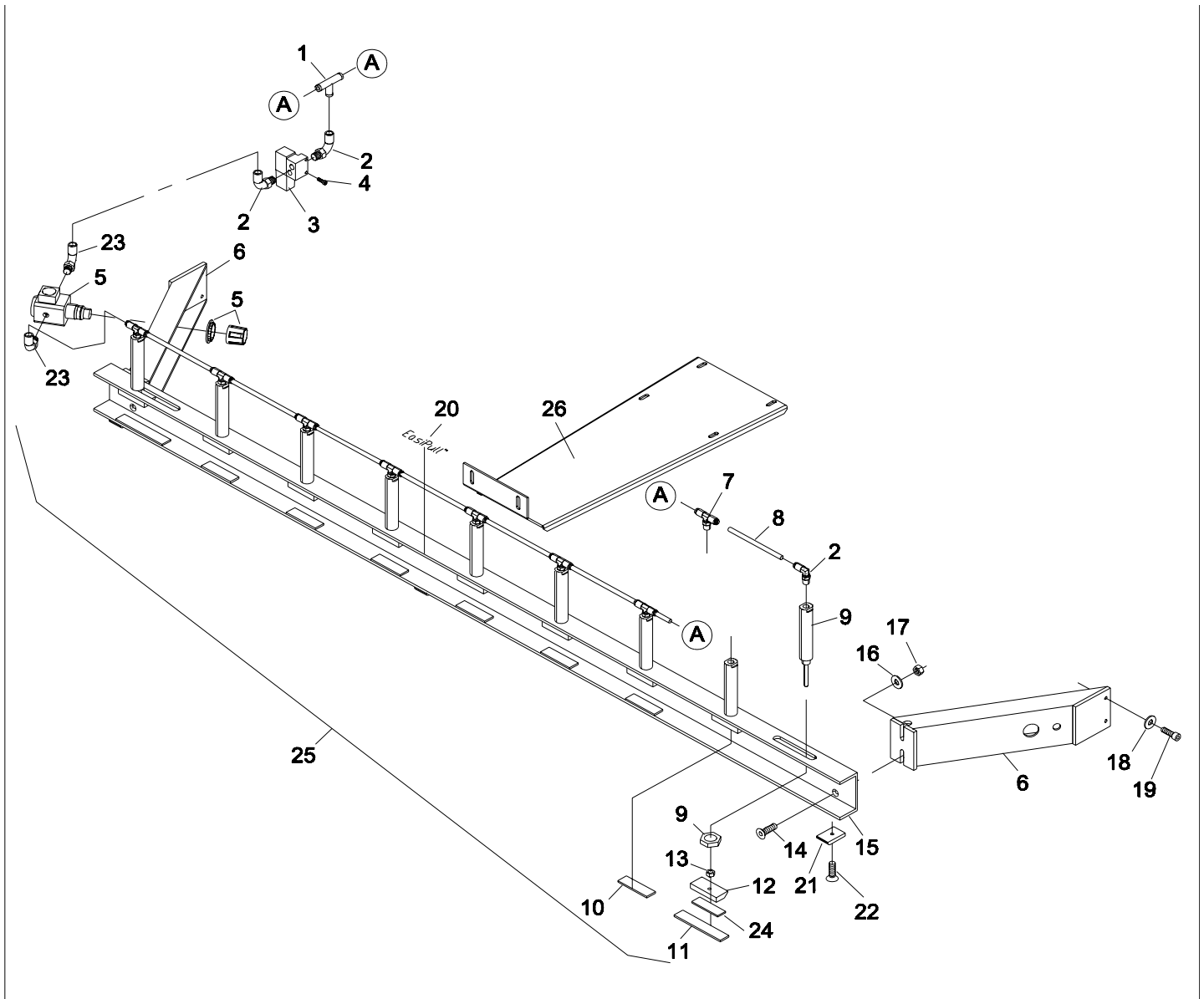

Easi Pull Cable (31-26025-ms) Not Shown

ITEM	PART No.	DESCRIPTION	QTY
1	100-14-1	TEE, 1/4 pushon	A/R
2	100-13-7	Elbow, 1/8 npt, 1/4 pushon	3
3	100-18-21	Valve, 12v Solenoid	1
4	335-93-8	Screw, Socket Hd. #8-32 x 1/2	2
5	100-18-17	Regulator	1
6	P-04546	Bracket, Mounting	2
	P-04546-1	Bracket, Mounting (short)	2
7	100-14-4	TEE, 1/8npt, 1/4 pushon	A/R
8	100-10-6	1/4" Tubing	A/R
9	100-20-2	Clamp Cylinder	A/R
10	P-12925	Notch Pad, Short	A/R
11	P-12925-1	Notch Pad, Long	2
12	P-12783	Gripper Pad	A/R
13	203-35	Nut, Hex 1/4-28	A/R
14	332-34-12	Screw, Flat Hd. 1/4-20 x 3/4	4
15	P-40231-MS	Gripper Channel	1
16	410-34	Washer, Flat 1/4	4
17	216-34	Flange Nut, 1/4-20	4
18	410-34	Washer, Flat 1/4	4
19	335-34-8	Screw, Socket Hd. 1/4-20 x 1/2	4
20	91-00562	Decal, Easi Pull	1
21	CHT-1140	Bumper	3
22	332-99-8	Screw, Socket Hd. #10-24 x 1/2	3
23	100-13-2	Elbow, 1/4 npt, 1/4 pushon	2
24	9068-004	Grip Tape	A/R
25	P-04545-MS	Gripper Assembly	1
26	54-26194	Gripper Mount, Optional	A/R

A/R - As Required

MS-Machine size

(A)	100-10-6	1/4" Tubing	A/R
-----	----------	-------------	-----

Technical Data EASTMAN® ETS-M9000

ETS-M9000

Maximum Machine Speed*	60 in/sec. (150 cm/sec.)
Maximum Table Length	None
Cut Accuracy*	+/- .015" (+/- .4 mm)
Gantry Weight	Approx. 200 lbs. (145 kg)
M9000 Operating Voltage	110v; 60hz
Blower Operating Voltage	220v; 60hz
Power Requirement (M9000)	110V/20A
(Blowers)	220V/25A
Minimum Operating Pressure	75 PSI
Volume of Air Service	5 SCFM
Minimum Temperature	55° non-condensing

Information based on a standard 72" Maximum cutting capacity machine.

* Relative to the type and quality of fabric, Cutting speed, Pulling mode, Operational Settings etc.

Machine Size	Working Width	Table Width (Including Rack & Rail)	Overall Machine Width
60" (1530 mm)	58.6" (1488 mm)	72" (1830 mm)	91" (2310 mm)
66" (1680 mm)	64.6" (1641 mm)	78" (1980 mm)	97" (2464 mm)
72" (1830 mm)	70.6" (1793 mm)	84" (2130 mm)	103" (2616 mm)
78" (1980 mm)	76.6" (1946 mm)	90" (2290 mm)	109" (2770 mm)

Please allow 3 ft working clearance on all sides.

* For all other sizes consult factory.

Limited Warranty. Eastman warrants to the buyer that the equipment shall be free from defects in materials or workmanship for a period of 180 days commencing on the date of invoice. Any goods or parts claimed by the buyer to be defective must be returned to Eastman, freight charges prepaid, within the 180-day warranty period. If Eastman determines that the goods or parts are defective in materials or workmanship, Eastman's sole obligation under this warranty shall be, at Eastman's sole option, to repair or replace the defective goods or parts or to provide the buyer a credit equal to the portion of the purchase price allocable to the defective goods or parts. This warranty shall not apply if defects are caused by product misuse or neglect, if the machine has been altered or modified by the buyer, or if other than genuine Eastman belts, emery wheels, knives or parts are used in the machine. THIS WARRANTY IS THE ONLY WARRANTY APPLICABLE TO THIS PURCHASE. SELLER DISCLAIMS ALL OTHER WARRANTIES, EXPRESS OR IMPLIED, INCLUDING, BUT NOT LIMITED TO, THE IMPLIED WARRANTIES OF MERCHANTABILITY AND FITNESS FOR A PARTICULAR PURPOSE.

Limitation of Liability. Eastman's liability to the buyer, and the buyer's remedies from Eastman, whether in contract, negligence, tort, under any warranty or otherwise, shall be limited to the remedies provided in the foregoing Limited Warranty. In no event shall Eastman have any responsibility or liability to the buyer for (a) any special, indirect, incidental, or consequential damages, including, but not limited to, loss of use, revenue, or profit, even if Eastman has been advised of the possibility of such damages, or (b) any claim against the buyer by any third party. The price stated for the product sold is a consideration for limiting Eastman's liability.