

471

474

Teileliste

Parts list

Liste de pièces

Lista de piezas

491

Diese Teileliste hat für Maschinen ab nachfolgender
Seriennummer Gültigkeit:
This parts list applies to machines from the following
serial numbers onwards:
Cette liste de pièces est valable pour les machines au
numéros de série à partir de:
Esta lista de piezas tiene validez para máquinas a partir del
número de serie siguiente:
PFAFF 471 # 2560474 →
PFAFF 474 # 2561194 →
PFAFF 491 # 2561421 →

Alle Informationen und Abbildungen waren zum Zeitpunkt der Druckgebung auf dem neusten Stand.

Technische Änderungen vorbehalten!

Der Nachdruck, die Vervielfältigung sowie die Übersetzung - auch auszugsweise - aus PFAFF-Teilelisten ist nur mit unserer vorherigen Zustimmung und mit der Quellenangabe gestattet.

At the time of printing, all information and illustrations contained in this a document were up to date.

Subject to alteration!

The reprinting, copying or translation of PFAFF Parts lists whether in whole or in part, is only permitted with our previous permission and with written reference to the source.

Au moment de la remise à l'imprimeur, toutes les informations et figures se rapportant à cette machine correspondaient à l'état actuel des connaissances.

Sous réserve de modifications techniques!

Aucune reproduction, photocopie ou traduction - même par extraits - des listes de pièces PFAFF ne peut être effectuée, à condition d'en indiquer l'origine, sans notre autorisation expresse.

Todas las informaciones e ilustraciones de este manual estaban al día en el momento de entregarse para su impresión.

¡ Salvo modificaciones técnicas!

La reimpresión, reproducción y traducción - aunque sólo sea parcial - de las listas de piezas PFAFF sólo está permitida con nuestro permiso previo e indicando la fuente.

**G.M. PFAFF KAISERSLAUTERN
INDUSTRIEMASCHINEN AG**

Postfach 3020
D-67653 Kaiserslautern

Königstr. 154
D-67655 Kaiserslautern

Redaktion/Illustration
Verlag Technische Dokumentation
Postfach 1106
D-77901 Lahr

		Seite Page Page Página
0	Wichtiger Hinweis Important note Avis important Observación importante	0 - 1
1	Vorwort Foreword Avant-propos Notas preliminares	1 - 1
2	Erläuterungen der Schlüsselzeichen Explanation of key markings Explication des symboles Explicaciones de los signos clave	2 - 1
3	Basismaschine Basic machine Machine de base Máquina básicas	
3.01	Gehäuseteile Housing sections Parties du corps Piezas del cárter	3 - 1
3.02	Kopfteile Needle head parts Pièces de tête Piezas de la cabeza	3 - 2
3.03	Armteile Arm parts Pièces de bras Piezas del brazo	3 - 7
3.04	Grundplattenteile Bedplate parts Pièces du plateau fondamental Piezas del cárter	3 - 11
4	Säule vollständig Post assy. Colonne complète Columna completo	

		Seite Page Page Página
4.01	Greifersäule, links Hook post, left Pilier à crochet, gauche Columna del garfio, a la izquierda	4 - 1
4.02	Greifersäule, rechts Hook post, right Pilier à crochet, droit Columna del garfio, a la derecha	4 - 3
4.03	Schiebradsäule, links Feed wheel post, left Pilier à roue d'entraînement, gauche Columna del arrastre por rueda, a la izquierda	4 - 8
4.04	Schiebrad-Trägerplatte Feed wheel mounting plate Plaque support de la roue d'entraînement Placa soporte del arrastre por rueda	4 - 9
5	Kantenbeschneideinrichtung (-725/04) Edge trimmer (-725/04) Couteau (-725/04) Recortador (-725/04)	5 - 1
6	Kantenbeschneideinrichtung (-726/05) Edge trimmer (-726/05) Couteau (-726/05) Recortador (-726/05)	6 - 1
7	Fadenabschneid-Einrichtung (-900/53) Thread trimmer (-900/53) Coupe-fil (-900/53) Cortahilos (-900/53)	7 - 1
8	Fadenspannungssteuerung (-906/10) Thread tension control (-906/10) Commande de la tension du fil (-906/10) Ti control de la tensión del hilo superior (-906/10)	8 - 1
9	Presserfuß-Automatik (-910/15) Automatic presser foot lifter (-910/15) Relève-pied automatique (-910/15) Alzaprensatelas (-910/15)	9 - 1

	Seite Page Page Página
10 Verriegelungs-Einrichtung (-911/35) Backtacking mechanism (-911/35) Dispositif à points d'arrêt (-911/35) Rematador (-911/35)	10 - 1
11 Wartungseinheit (-925/03) Air filter / lubricator (-925/03) Conditionneur d'air comprimé (-925/03) Grupo acondicionador del aire comprimido (-925/03)	11 - 1
12 Pneumatische Ausrüstung Pneumatic equipment Equipement pneumatique Equipo neumático	12 - 1
13 Elektrische Ausrüstung Electrical equipment Equipement électrique Equipo eléctrico	
13.01 Kabelbaum zum Oberteil Cable tree to sewing head Faisceau de câbles vers la tête de machine Mazo de cables para el cabezal	13 - 1
13.02 Tastschalter Push-button switch Interrupteur à bouton-poussoir Interruptor pulsador	13 - 2
13.03 Einbaumotor, Positionsgeber Built-in motor, Synchronizer Moteur incorporé, Synchronisateur Motor incorporado, Sincronizador	13 - 3
13.04 Sollwertgeber Set-point generator Codeur Emisor del valor teórico	13 - 4
13.05 Steuerkasten Control box Boîtier de contrôle Caja de mandos	13 - 5

	Seite Page Page Página
13.06 Steuerggerät Control device Boîte de commande Caja de mandos	13 - 6
13.07 Motordrehschalter Motor turn switch Interrupteur rotatif Interruptorgiratorio	13 - 7
14 Keilriemen V-belt Courroie trapézoïdale Correatrapezoidal	14 - 1
15 Knielüfterteile Knee lifter parts Pièces du releveur de genouillère Piezas del alzaprensateles por rodillera	14 - 1
16 Garnrollenständer Reel stands Porte-bobines Portacarretes	16 - 1
17 Einstellehren Adjustment gauges Calibres Calibres de ajuste	17 - 1
18 Teile zur Tischplatte Parts for table top Pièces du plateau Piezas para el tablero	17 - 1
19 Schmiermittel-Übersicht Overview of lubricants Tableau de lubrifiants Tabla de lubricantes	19 - 1
20 Index (Teilenummern / Seitenzahlen) Index (part numbers / page numbers) Index (numéros de pièces, de pages) Index (números de pieza / números de página)	20 - 1

21	Unterklassen-Ausstattung Subclass parts Composition des sous-classes Composición de las subclases		
21.01	Nähwerkzeuge (PFAFF 471) Gauge parts (PFAFF 471) Organes de couture (PFAFF 471) Organos de costura (PFAFF 471)	21	- 2
21.02	Nähwerkzeuge (PFAFF 474) Gauge parts (PFAFF 474) Organes de couture (PFAFF 474) Organos de costura (PFAFF 474)	21	- 7
21.03	Nähwerkzeuge (PFAFF 491) Gauge parts (PFAFF 491) Organes de couture (PFAFF 491) Organos de costura (PFAFF 491)	21	- 15



Achtung!



Wir machen ausdrücklich darauf aufmerksam, daß Ersatz- und Zubehörteile, die nicht von uns geliefert werden, auch nicht von uns geprüft und freigegeben sind. Der Einbau und / oder die Verwendung solcher Produkte kann daher u. Umständen konstruktiv vorgegebene Eigenschaften Ihrer Maschine negativ verändern. Für Schäden, die durch die Verwendung von Nicht-Originalteilen entstehen, übernehmen wir keine Haftung!

Caution!



We warn you expressively that spare parts and accessories that are not supplied by us are not tested and released by us. Fitting or using these products may therefore have negative influences on features that depend on the machine design. We are not liable for any damage caused by the use of non-Pfaff parts!

Attention!



Nous attirons expressément votre attention sur le fait que les pièces de rechange et accessoires qui n'ont pas été livrés par nous n'ont pas non plus été contrôlés et agréés par nous. C'est pourquoi le montage et/ou l'utilisation de telles pièces peut éventuellement entraîner l'altération des caractéristiques de construction de votre machine. Par conséquent, nous n'assumons aucune responsabilité pour les dommages causés par l'emploi de pièces qui ne sont pas d'origine!

¡Atención!



Se hace observar que en el caso de piezas de recambio y accesorios que no hayan sido suministrados por nosotros, quiere decir que non han sido sometidas por nuestra parte a un control y que no se les ha dado el visto bueno. Por esta razón, el montaje y/o empleo de tales productos puede repercutir negativamente en las características previstas en su máquina. ¡Para los daños que eventualmente pudiesen presentarse al utilizar piezas no originales, no asumimos ninguna garantía!

- Die Seriennummer der Maschine, für die diese Teileliste Gültigkeit hat, ist auf der Titelseite aufgeführt.
 - Alle Teile sind so abgebildet, wie sie in der Maschine funktionsmäßig zusammengehören.
 - Gestrichelt dargestellte Teile zeigen angrenzende Teile aus anderen Funktionsgruppen.
 - Im oberen Teil der Bildseiten befindet sich eine Gesamtansicht der Maschine .
 - Der Einbauort der dargestellten Teile wird durch eine gerasterte Fläche gekennzeichnet.
 - Einrahmungen auf den Bildseiten zeigen, aus welchen Einzelteilen sich die Gruppenteile zusammensetzen.
 - Die auf den Bildseiten verwendeten Schlüsselzeichen (; 2 ; 3 usw.) sind im Kapitel "Erläuterungen der Schlüsselzeichen" aufgelistet.
-
- The serial number of the machine to which this parts list applies is indicated on the cover page.
 - All parts are illustrated in function groups with the parts which they function together with in the machine.
 - Parts illustrated with broken lines are parts from other function groups which border on the illustrated function group.
 - The above section of the page of illustrations contains a total view of the machine. The place for the installation of the parts pictured here is marked by the grid.
 - The framed-in sections on the illustration pages show the individual parts comprising a group.
 - The key markings used on the illustrated pages (; 2 ; 3 etc.) are listed in the chapter "Explanation of key markings".
-
- Le numéro de série de la machine pour laquelle cette liste de pièces est valable est indiqué sur la première page.
 - Toutes les pièces sont représentées en fonction de leur groupement fonctionnel dans la machine.
 - Les pièces hâchurées indiquent les pièces limitrophes de groupes de fonctions différents.
 - La partie supérieure des pages de figures comprend une présentation globale de la machine. L'emplacement des pièces représentées est signalé par quadrillages.
 - Les parties encadrées sur les pages à illustrations représentent les pièces individuelles formant groupe.
 - Vous trouverez au chapitre "Explication des symboles" une liste des symboles utilisés sur les pages de figures (; 2 ; 3 etc.)
-
- El número de serie de la máquina para la cual tiene validez esta lista de piezas va indicado en la página de título.
 - Todas las piezas están ilustradas tal como aparecen en la máquina para su funcionamiento.
 - Las piezas representadas con rayitas muestran piezas colindantes de otros grupos de funciones.
 - En la parte superior de las páginas ilustradas se puede ver una vista en conjunto de la máquina.
 - El lugar de montaje de la pieza representada va caracterizada mediante una superficie reticulada.
 - Los recuadros en las páginas ilustradas indican las piezas individuales de que se componen los grupos.
 - Los signos clave (; 2 ; 3 etc.) empleados en las páginas con ilustraciones van listados en el capítulo "Explicaciones de los signos clave".

<input type="checkbox"/>	Unterklassenabhängig, Teilenummer siehe Unterklassen-Ausstattung. Subclas-dependent, for part number see subclass parts listing. Fonction de la sous-classe; pour le numéro de la pièce, voir "Équipement de sous-classes". Dependientes de la subclase, para el número de pieza véase "Dotación de subclases".
A	Maschinen-Ausstattung für feine Materialien. Model A for sewing thin and light-weight materials. Modèle A pour la couture de tissus fins et légers. Tipo A para materiales ligeros.
B	Maschinen-Ausstattung für mittlere Materialien. Model B for sewing medium-weight materials. Modèle B pour la couture de matières moyennes. Tipo B para materiales semiligeros.
B/C	Maschinen-Ausstattung wie B, jedoch mit größerem Stichloch (2,2 mm). Machine equipped as model B, but with larger needle hole (2.2 mm). Machine prévue comme en B, mais avec trou d'aiguille plus grand (2,2 mm). Tipo de máquina como B, pero con agujero de la placa de aguja más grande (2,2 mm).
N3,6	Stichlänge 3,6 mm. Stitch length 3.6 mm. Longeur du point 3,6 mm. Largo de puntada 3,6 mm.
4,5	Stichlänge 4,5 mm. Stitch length 4.5 mm. Longeur du point 4,5 mm. Largo de puntada 4,5 mm.
N7	Stichlänge 7,0 mm. Stitch length 7.0 mm. Longeur du point 7,0 mm. Largo de puntada 7,0 mm.
2	Markierung (Punkte, Striche oder Zahl) bei Bestellung angeben. Marking (dots, strokes or numbers) to be stated on order. Préciser les repères (points, traits ou chiffres) à la commande. Señales (puntos, rayas o cifras), indíquese en los pedidos.
3	Geklebt Part cemented Pièce collée Pieza pegada

- 3/1 Gesichert mit Loctite.
Secured with Loctite.
Bloqué par Loctite.
Asegurado con Loctite.
- 5 Nähmuster bzw. Material einsenden.
Submit sewing sample or material.
Joindre échantillons de couture ou matières.
Envíense muestras de costura.
- 6 Nadeldicke und Spitzenform bei Bestellung angeben.
Needle size and style of point to be stated on order.
Préciser la grosseur de l'aiguille et la forme de la pointe à la commande.
Grosor de aguja y forma de la punta, indíquese en los pedidos.
- 7/1 Messer mit aufgebogenem Dach und langer Schneide.
Knife with bent-up front corner and long cutting edge.
Couteau à dos relevé et tranchant long.
Cuchilla con hoja arqueada y filo largo.
- 7/3 Messer mit flachem Dach und langer Schneide.
Knife with flat front corner and long cutting edge.
Couteau à dos plat et tranchant long.
Cuchilla con hoja plana y filo largo.
- 7/4 Messer mit aufgebogenem Dach und kurzer Schneide.
Knife with bent-up front corner and short cutting edge.
Couteau à dos relevé et tranchant court.
Cuchilla con hoja arqueada y filo corto,
- 7/5 Messer mit flachem Dach und Doppelschneide.
Knife with flat front corner and dual cutting edge.
Couteau à dos plat et tranchant double.
Cuchilla con hoja plana y doble filo.
- 7/6 Messer mit flachem Dach und kurzer Schneide.
Knife with flat front corner and short cutting edge.
Couteau à dos plat et tranchant court.
Cuchilla con hoja plana y filo corto.
- 7/17 Messer (flache Ausführung) mit aufgebogener vorderer Ecke.
Knife (flat version) with bent-up front corner.
Couteau (version plate) doigt anttér. légèrement relevé.
Cuchilla (tipo plano) con esquina anterior levantada.

- 7/18 Messer (flache Ausführung) mit aufgebogener vorderer Ecke und Aussparung.
Knife (flat version) with bent-up front corner and cutout.
Couteau (version plate) doigt antér. légèrement relevé, avec évidement.
Cuchilla (tipo plano) con esquina anterior levantada y rebaja.
- 7/19 Messer mit niedriger Abkröpfung, vorderer aufgebogener Ecke und kleiner Schneidwand.
Knife with slight bend, bent-up front corner and Short blade.
Couteau avec faible désaxage, coin avant coudé et petite hauteur du tranchant.
Cuchilla de acodamiento rebajado, esquina anterior levantada y altura pequeña del filo.
- 7/20 Messer mit vorderer aufgebogener Ecke.
Knife with raised front corner.
Couteau à coin avant relevé.
Cuchilla con ángulo anterior arqueado.
- 7/21 Messer ohne aufgebogener vorderer Ecke.
Knife without raised front corner.
Couteau sans coin avant relevé.
Cuchilla sin ángulo anterior arqueado.
- 7/22 Messer mit kurzer Abkröpfung, ohne aufgebogener vorderer Ecke.
Knife with short elvow, without raised front corner.
Couteau à coude court, sans coin avant relevé.
Cuchilla con codo corto, sin ángulo anterior arqueado.
- 9 Schneidabstand
Trimming margin
Distance de coupe
Margen de corte
- 10 Nadelabstand
Needle gauge
Ecartement des aiguilles
Distancia entre agujas
- 18 Schneidhöhe
Cutting height
Hauteur de coupe
Altura de corte
- 27/2 Eingeklammerte Zahl = Dicke in mm.
Number in brackets = thickness in mm.
Chiffre entre parenthèses = épaisseur en mm
Cifra entre paréntesis = espesor en mm.

- 27/5 Eingeklammerte Zahl = Länge in mm.
 Number in brackets = length in mm.
 Chiffre entre parenthèses = longueur en mm
 Cifra entre paréntesis = largura en mm.
- 28 Sonderausführung
 Special version
 Version spéciale
 Tipo especial
- 32 Beim Einbau dieses Teiles wird für die Paßgenauigkeit zum Anschlußteil keine Garantie
 übernommen; zweckmäßig vollständiges Aggregat bestellen.
 No guarantee is assumed that this part will fit the mating part; it is best to order a
 complete assembly.
 Aucune garantie ne pourra être assurée quant à la précision d'ajustage de cette pièce
 avec lapèce correspondante; il est indiqué de commander un mécanisme complet.
 Al montar esta pieza no se asume garantía alguna en cuanto a la tolerancia y precisión
 de ajuste respecto a la pieza correspondiente; por esta razón, se recomienda pedir el
 grupo completo.
- 40/2 Tränken mit 28-011 201-44; Bestellnummer siehe Seite 19 - 1.
 Soak with 28-011 201-44; for part number see page 19 - 1.
 Imbiber d'huile 28-011 201-44; n° de commande, voir page 19 - 1.
 Empape con aceite 28-011 201-44; para el Número de pedido véase la página 19 - 1.
- 40/3 Fetten mit 28-011 202-47; Bestellnummer siehe Seite 19 - 1.
 Grease with 28-011 202-47; for part number see page 19 - 1.
 Graiser avec de la graisse 28-011 202-47; n° de commande, voir page 19 - 1.
 Engrase con grasa 28-011 202-47; para el Número de pedido véase la página 19 - 1.
- 40/4 Fetten mit 28-011 202-43; Bestellnummer siehe Seite 19 - 1.
 Grease with 28-011 202-43; for part number see page 19 - 1.
 Graiser avec de la graisse 28-011 202-43; n° de commande, voir page 19 - 1.
 Engrase con grasa 28-011 202-43; para el Número de pedido véase la página 19 - 1.
- 40/6 Füllen mit 28-011 202-17; Bestellnummer siehe Seite 19 - 1.
 Top up with 28-011 202-17; for part number see page 19 - 1.
 Remplir de 28-011 202-17; n° de commande, voir page 19 - 1.
 Rellene con 28-011 202-17; para el Número de pedido véase la página 19 - 1.
- 40/7 Tränken mit 28-011 202-17; Bestellnummer siehe Seite 19 - 1.
 Soak with 28-011 202-17; for part number see page 19 - 1.
 Imbiber d'huile 28-011 202-17; n° de commande, voir page 19 - 1.
 Empape con aceite 28-011 202-17; para el Número de pedido véase la página 19 - 1.

- 40/13 Fetten mit 28-011 202-05; Bestellnummer siehe Seite 19 - 1.
Grease with 28-011 202-05; for part number see page 19 - 1.
Graiser avec de la graisse 28-011 202-05; n° de commande, voir page 19 - 1.
Engrase con grasa 28-011 202-05; para el Número de pedido véase la página 19 - 1.
- 41/2 Nadeldiagonalabstand bei Bestellung angeben.
Diagonal needle distance to be stated on order.
Préciser l'écartement diagonal des aiguilles à la commande.
Distancia diagonal entre agujas, indíquese en los pedidos.
- 60 Wahlweise
Optional
Au choix
Opcional
- 70/1 Rollfuß 35 mm \varnothing , 4,0 mm breit, gezahnt.
Roller presser, with 35 mm dia., 4.0 mm wide, toothed.
Pied à roulette, diamètre 35 mm, largeur 4,0 mm, denté.
Pie rodante de 35 mm de diámetro, 4,0 mm de ancho, dentado.
- 70/2 Rollfuß 35 mm \varnothing , 2,6 mm breit, glatt.
Roller presser, with 35 mm dia., 2.6 mm wide, smooth.
Pied à roulette, diamètre 35 mm, largeur 2,6 mm, lisse.
Pie rodante de 35 mm de diámetro, 2,6 mm de ancho, liso.
- 70/3 Rollfuß 25 mm \varnothing , 4,0 mm breit, gezahnt.
Roller presser, with 25 mm dia., 4.0 mm wide, toothed.
Pied à roulette, diamètre 25 mm, largeur 4,0 mm, denté.
Pie rodante de 25 mm de diámetro, 4,0 mm de ancho, dentado.
- 70/4 Rollfuß 25 mm \varnothing , 2,6 mm breit, gezahnt.
Roller presser, with 25 mm dia., 2.6 mm wide, toothed.
Pied à roulette, diamètre 25 mm, largeur 2,6 mm, denté.
Pie rodante de 25 mm de diámetro, 2,6 mm de ancho, dentado.
- 70/5 Rollfuß 25 mm \varnothing , 2,6 mm breit, glatt.
Roller presser, with 25 mm dia., 2.6 mm wide, smooth.
Pied à roulette, diamètre 25 mm, largeur 2,6 mm, lisse.
Pie rodante de 25 mm de diámetro, 2,6 mm de ancho, liso.
- 81/3 Verwendung je nach Bedarf.
To be used as required.
Utilisation en fonction besoins.
Utilización según sea necesario.

- | | |
|------|--|
| 90/1 | Für Wechselstrom
For single-phase A.C.
Pour du courant alternatif
Para corriente alterna monofásica |
| 90/2 | Für Drehstrom
For three-phase A.C.
Pour du courant triphasé
Para corriente alterna trifásica |
| 96 | Länge angeben.
State length.
Préciser longueur.
Indíquese la largura |

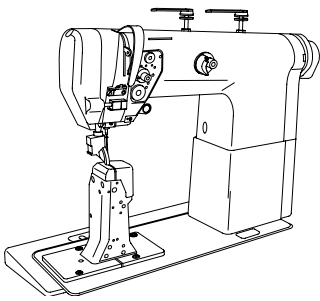

Gehäuseteile
 Housing sections PFAFF 471
 Parties du corps PFAFF 474
 Piezas del cárter PFAFF 491

3.01

91-165 372-71/893 (-725/04; -726/05; -900/53; -911/35)

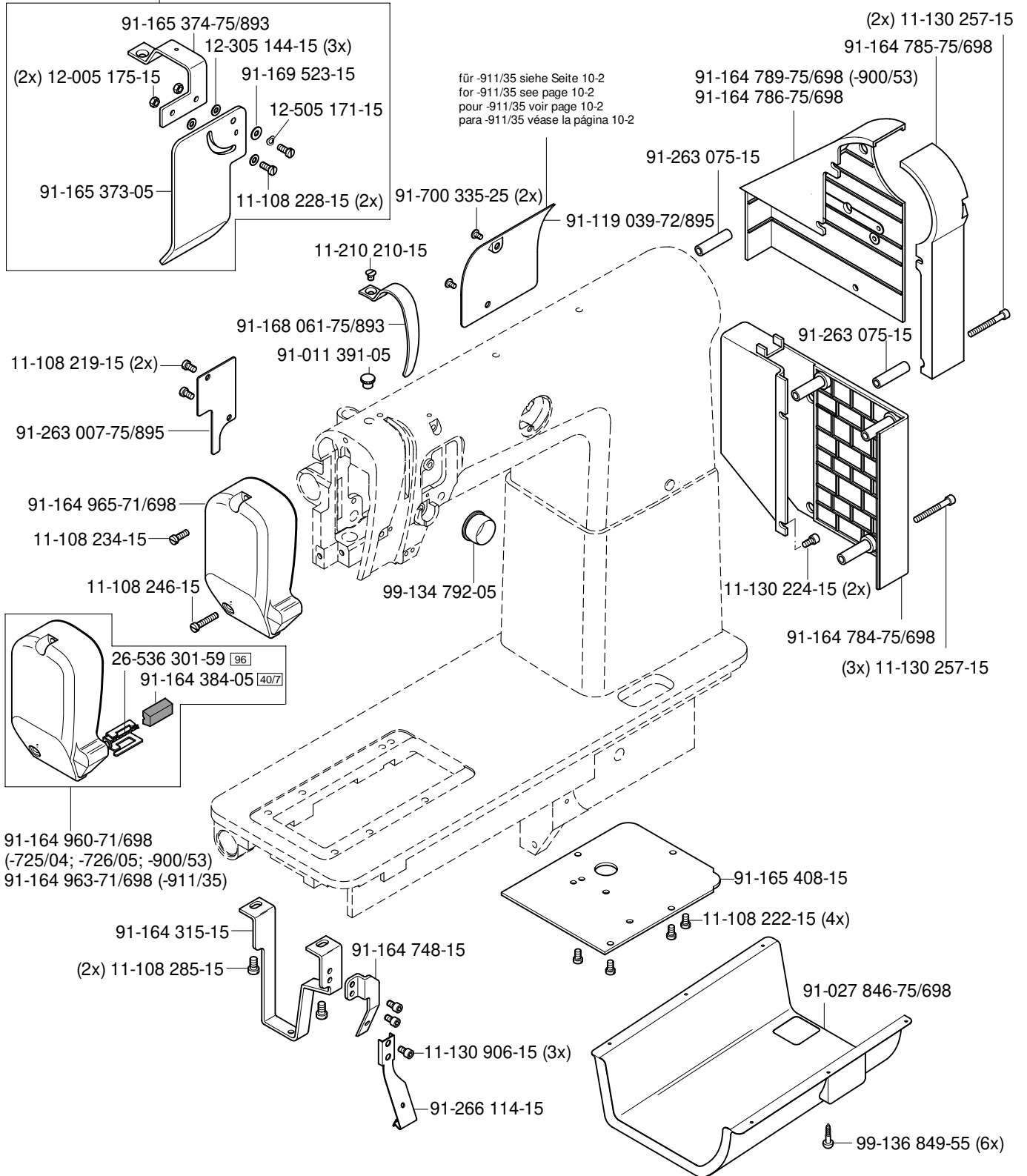

3.02

Kopfteile
Needle head parts PFAFF 471
Pièces de tête PFAFF 474
Piezas de la cabeza PFAFF 491

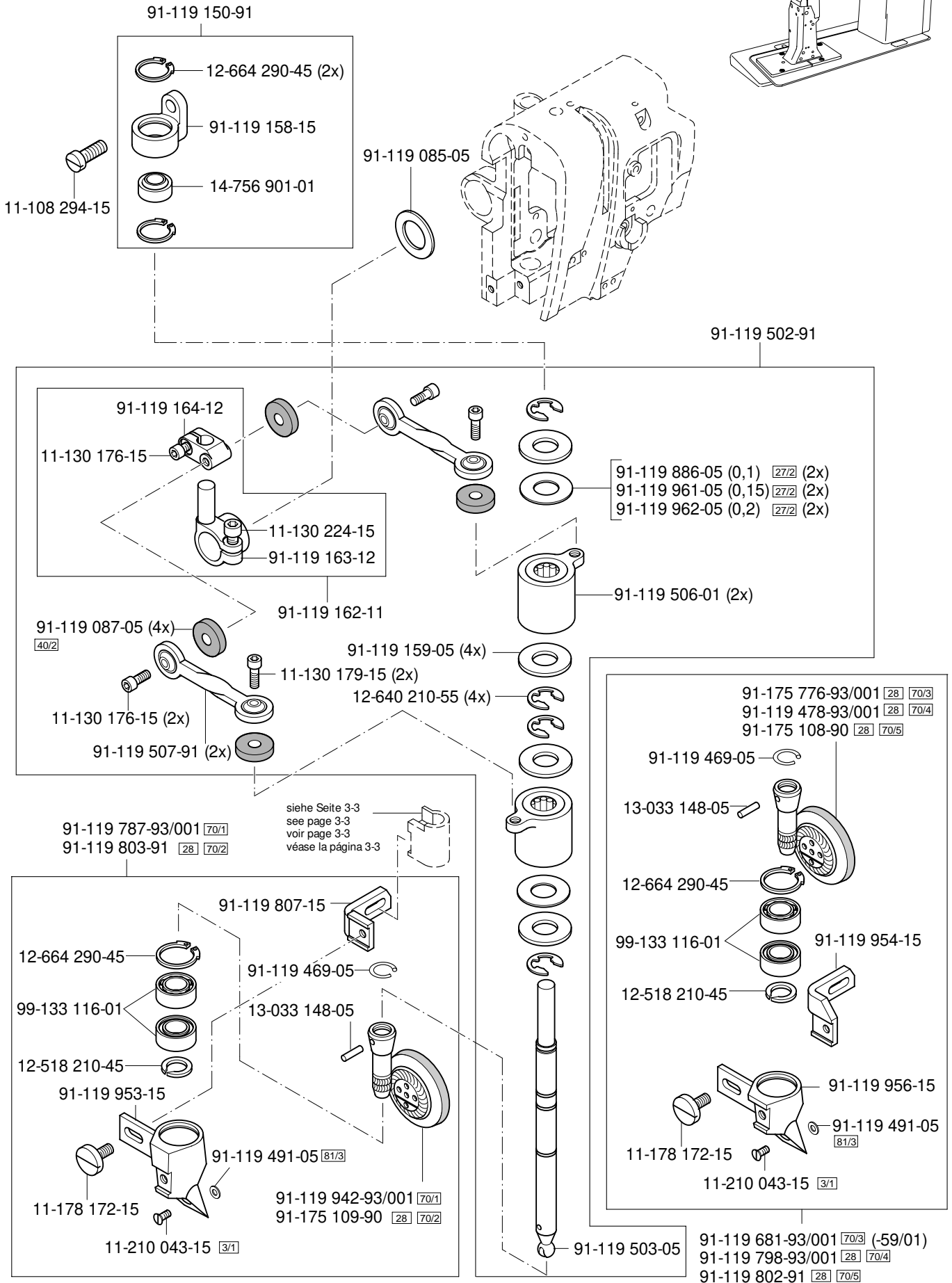
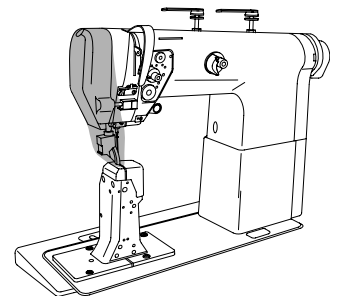

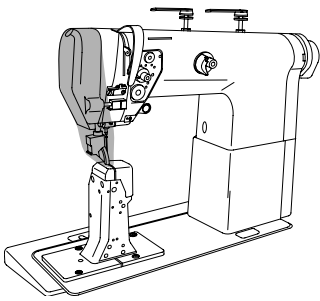

Kopfteile
Needle head parts PFAFF 471
Pièces de tête PFAFF 474
Piezas de la cabeza PFAFF 491

3.02

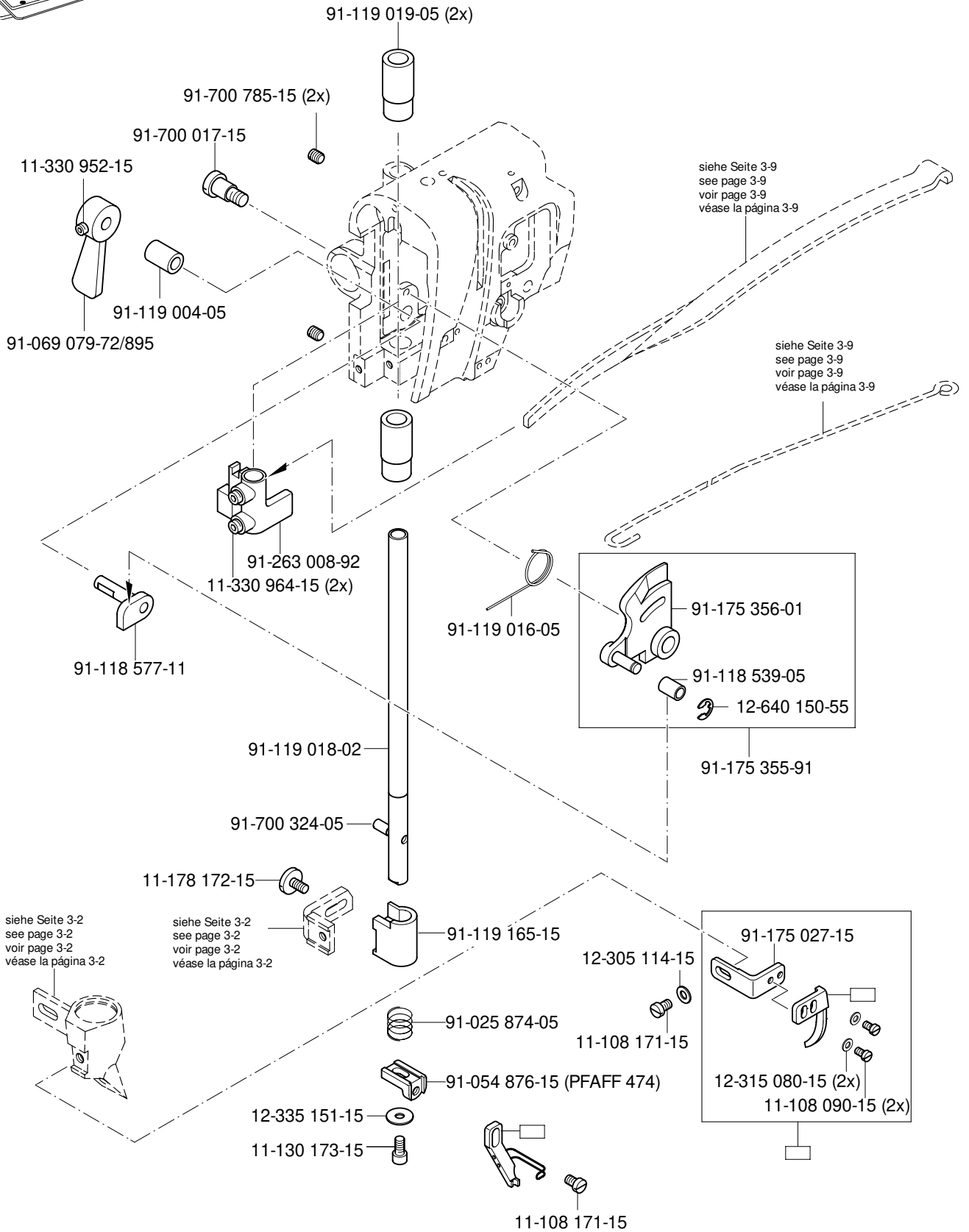

3.02

Kopfteile
Needle head parts PFAFF 471
Pièces de tête PFAFF 474
Piezas de la cabeza PFAFF 491

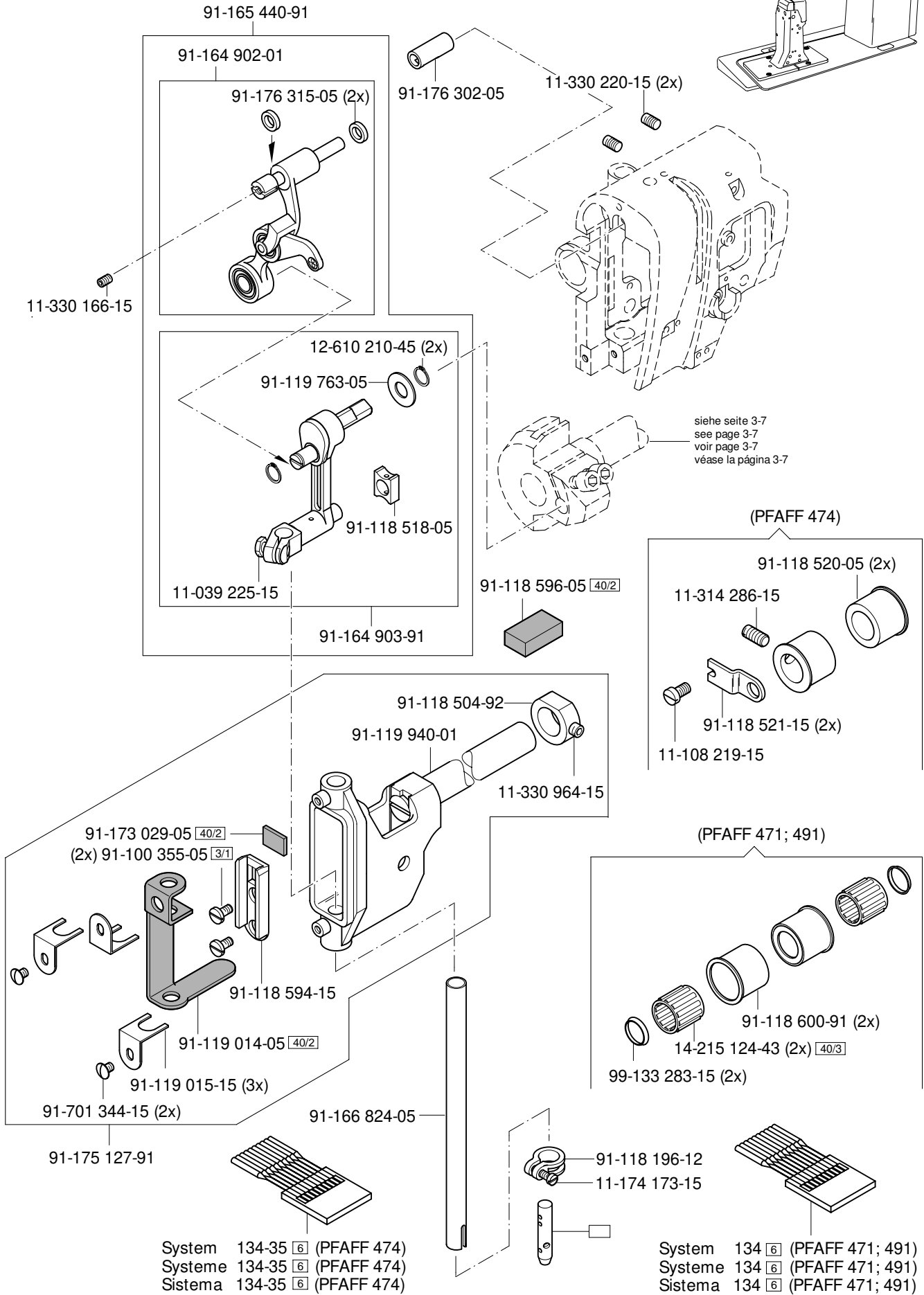
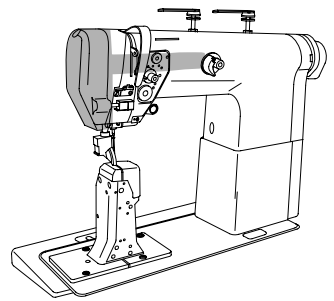

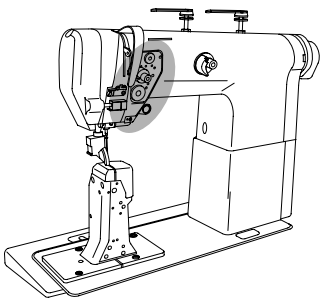

Kopfteile
 Needle head parts PFAFF 471
 Pièces de tête PFAFF 474
 Piezas de la cabeza PFAFF 491

3.03

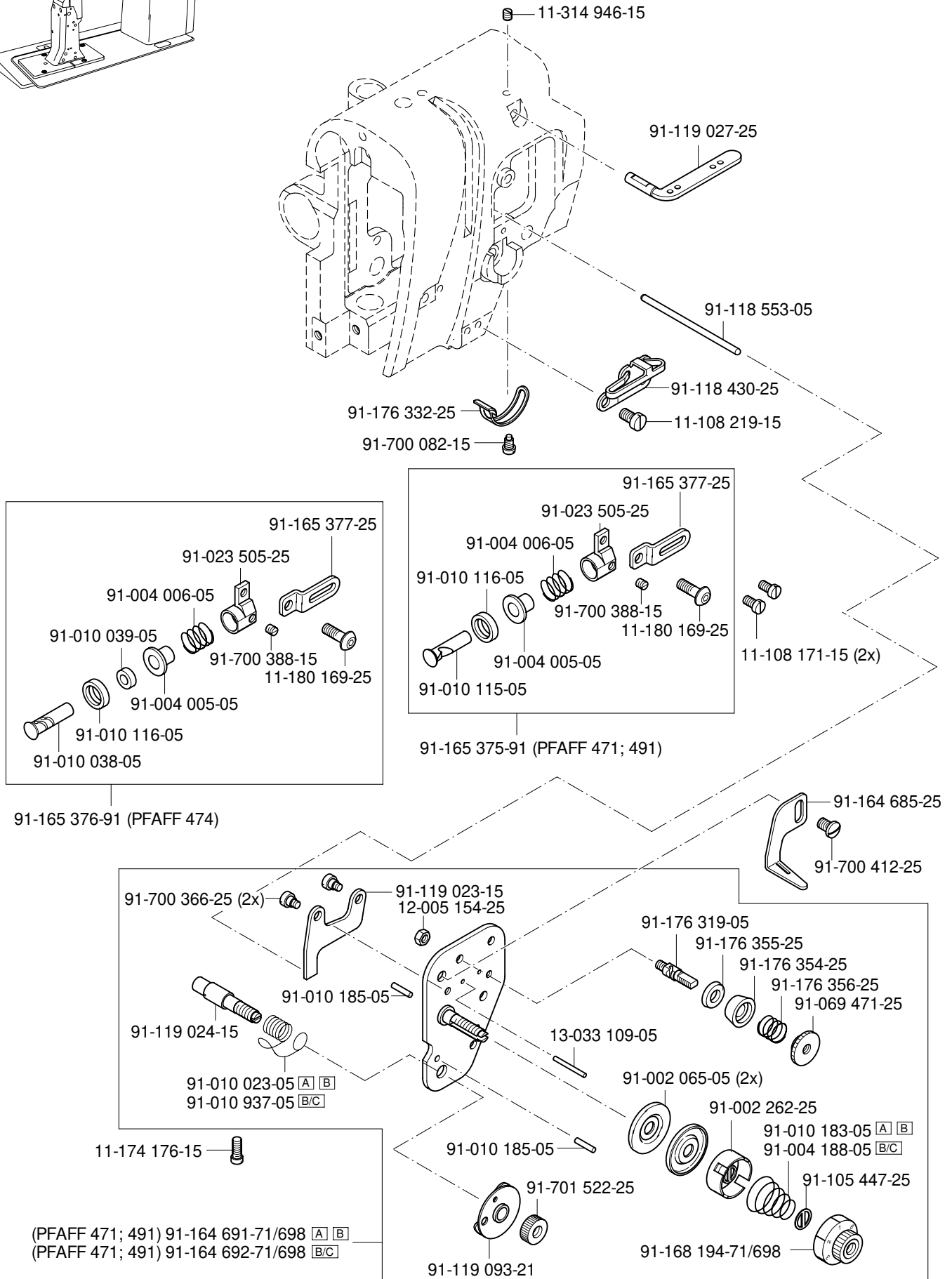

3.03

Kopfteile
 Needle head parts
 Pièces de tête
 Piezas de la cabeza PFAFF 474

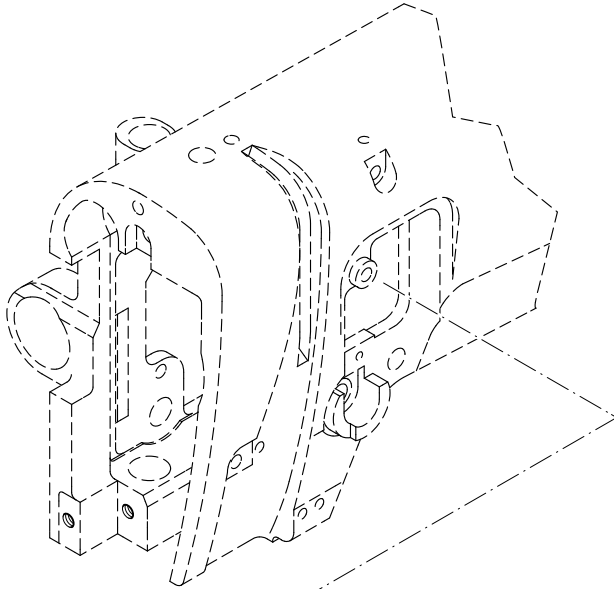
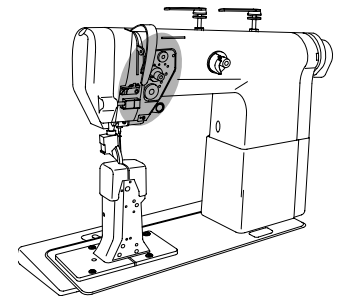

91-164 693-71/698 **A** **B** (PFAFF 474)
 91-164 694-71/698 **B/C** (PFAFF 474)

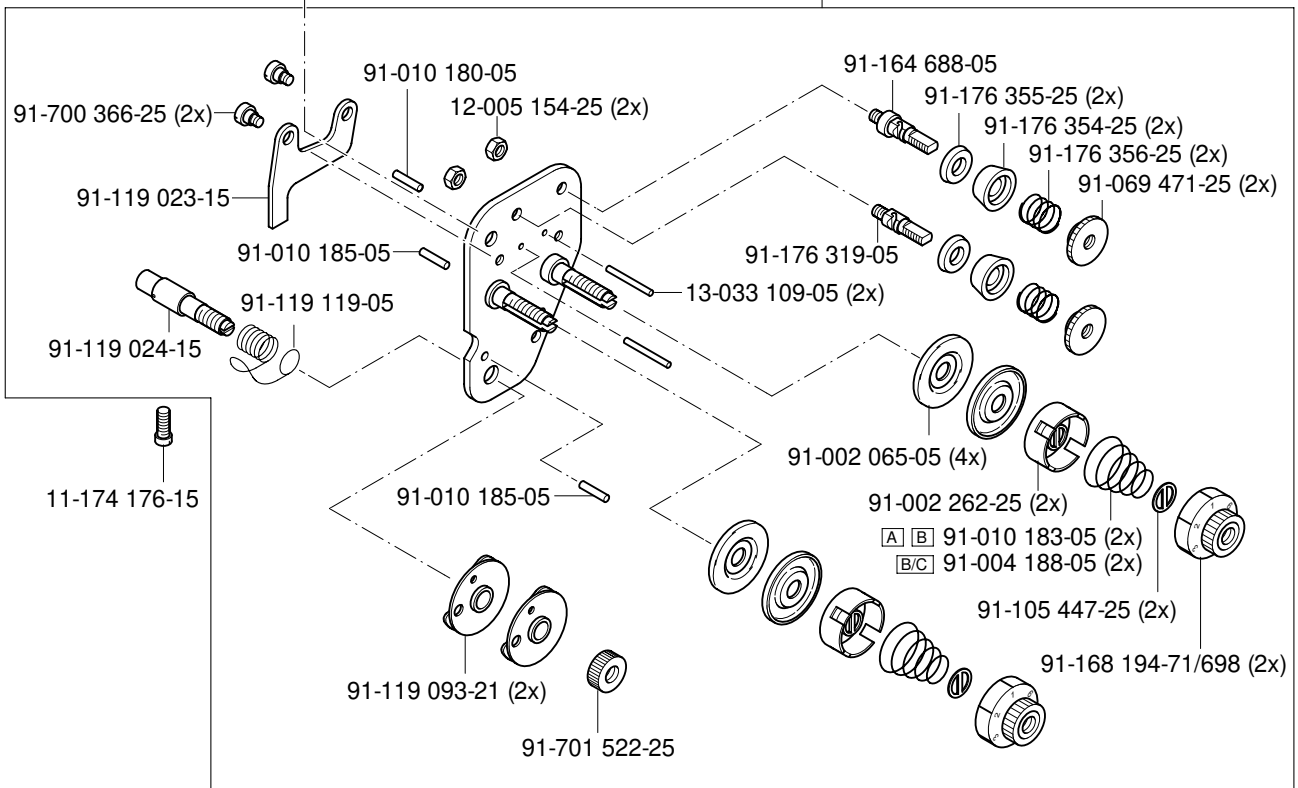

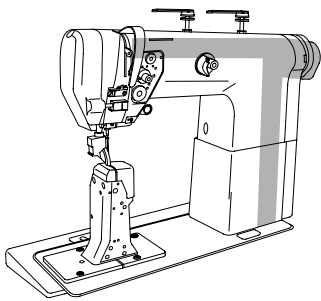

Armteile
 Arm parts PFAFF 471
 Pièces de bras PFAFF 474
 Piezas del brazo PFAFF 491

3.03

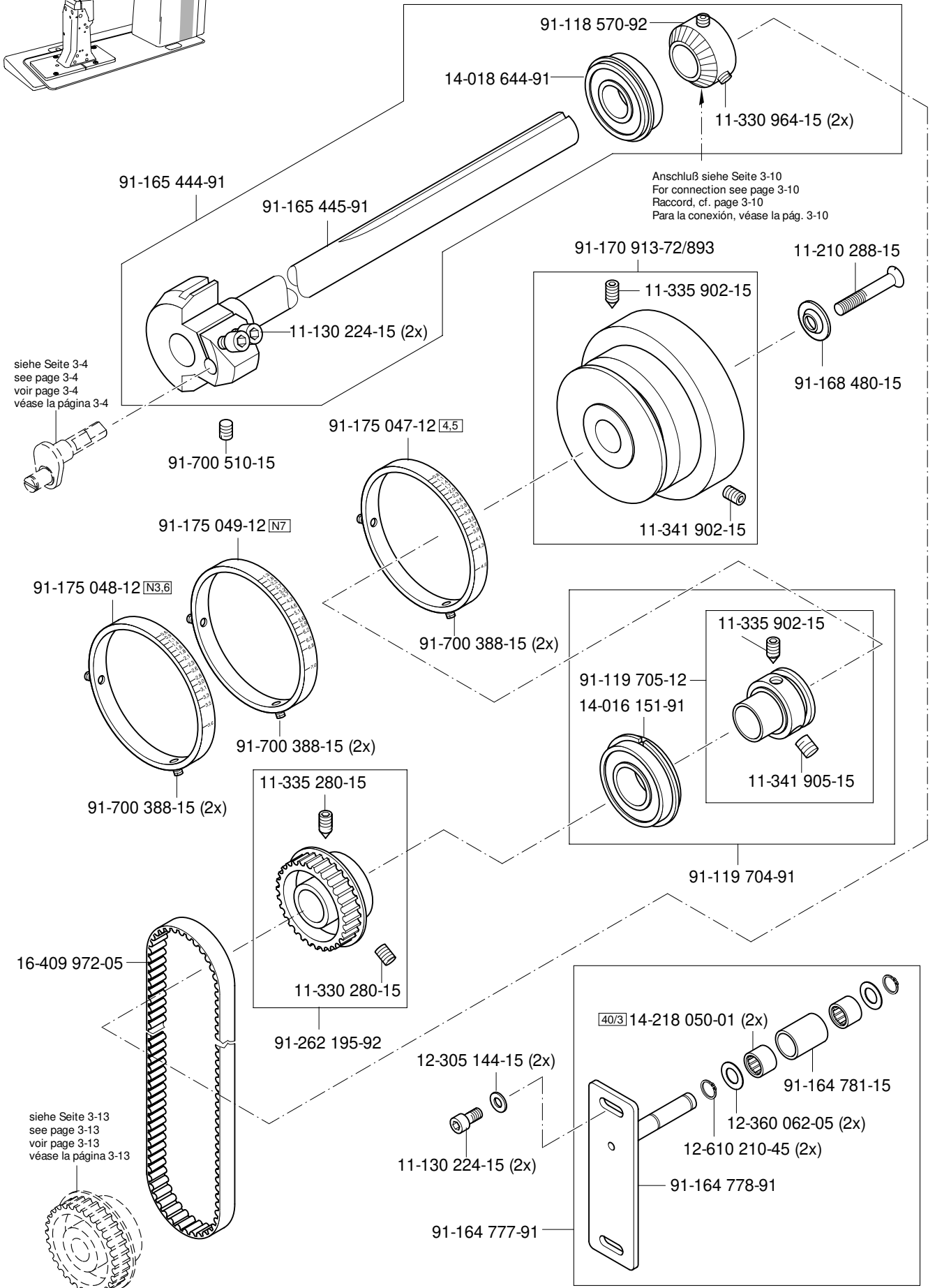

3.03

Armteile
 Arm parts PFAFF 471
 Pièces de bras PFAFF 474
 Piezas del brazo PFAFF 491

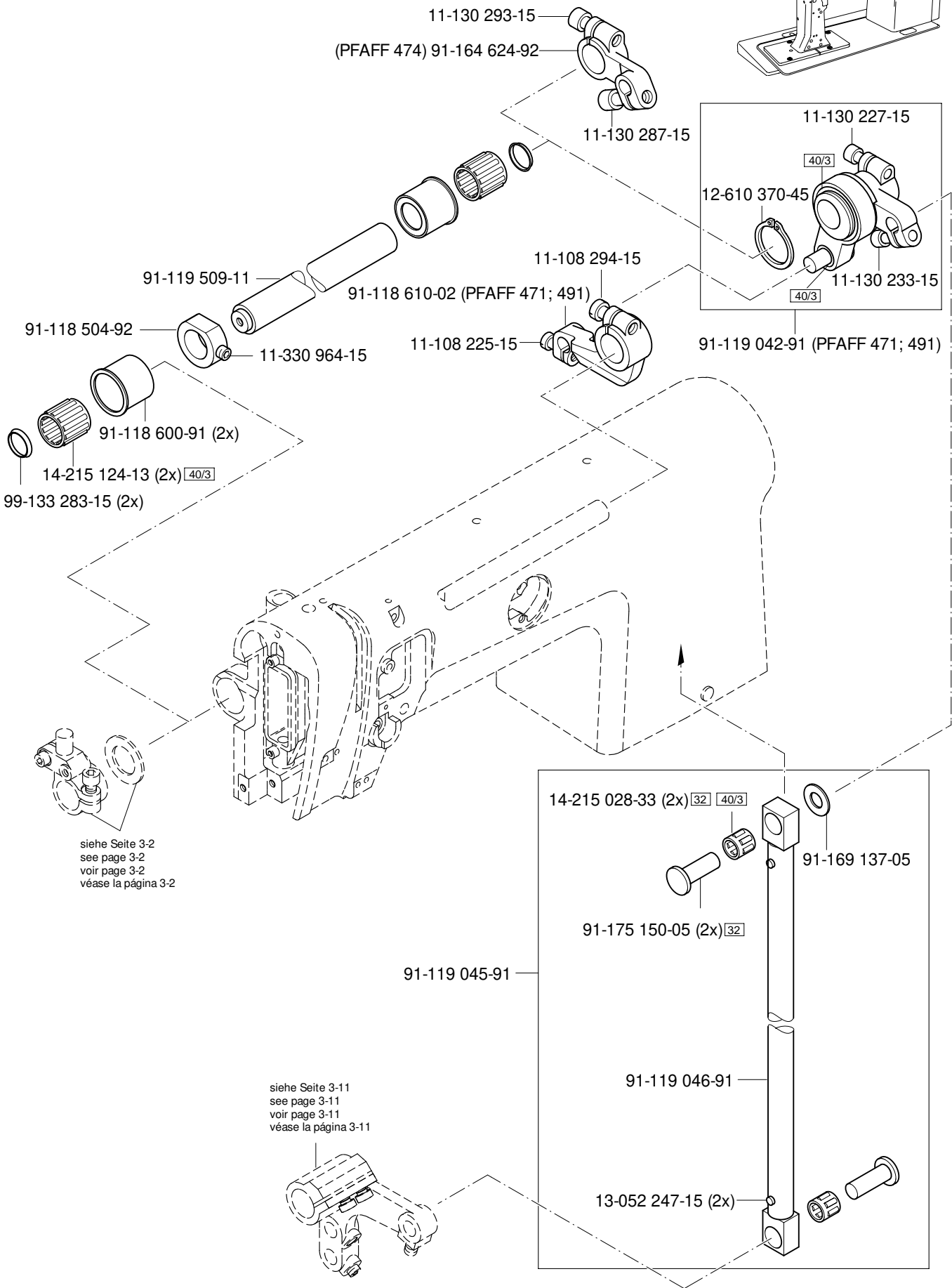
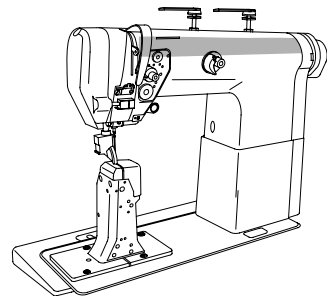

siehe Seite 3-2
 see page 3-2
 voir page 3-2
 véase la página 3-2

siehe Seite 3-11
 see page 3-11
 voir page 3-11
 véase la página 3-11

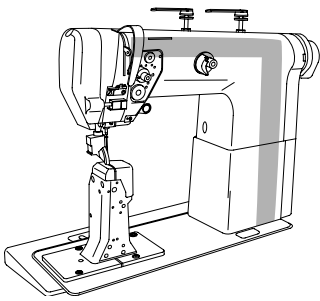

Armteile
 Arm parts PFAFF 471
 Pièces de bras PFAFF 474
 Piezas del brazo PFAFF 491

3.03

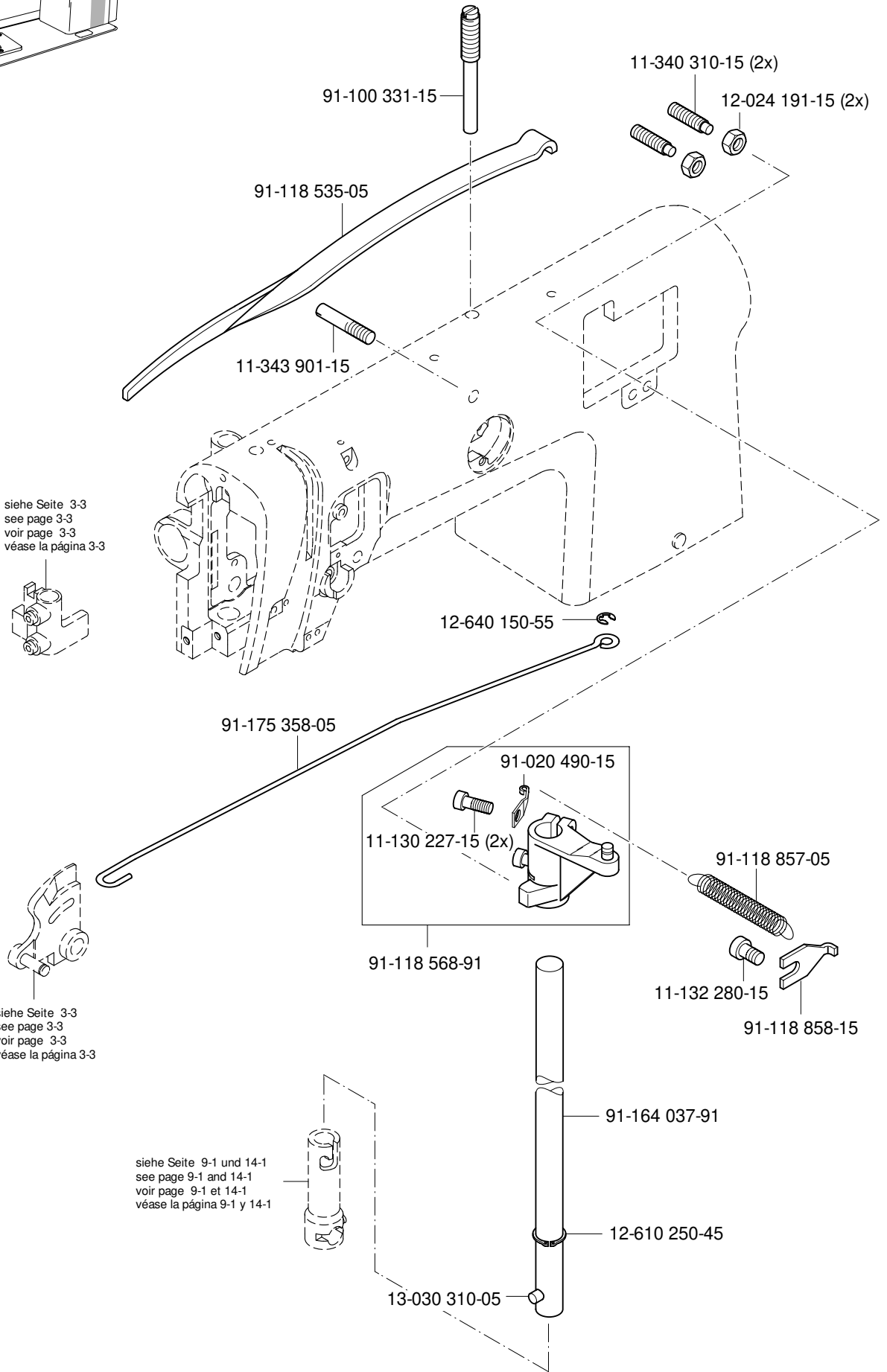

3.03

Armteile
 Arm parts PFAFF 471
 Pièces de bras PFAFF 474
 Piezas del brazo PFAFF 491

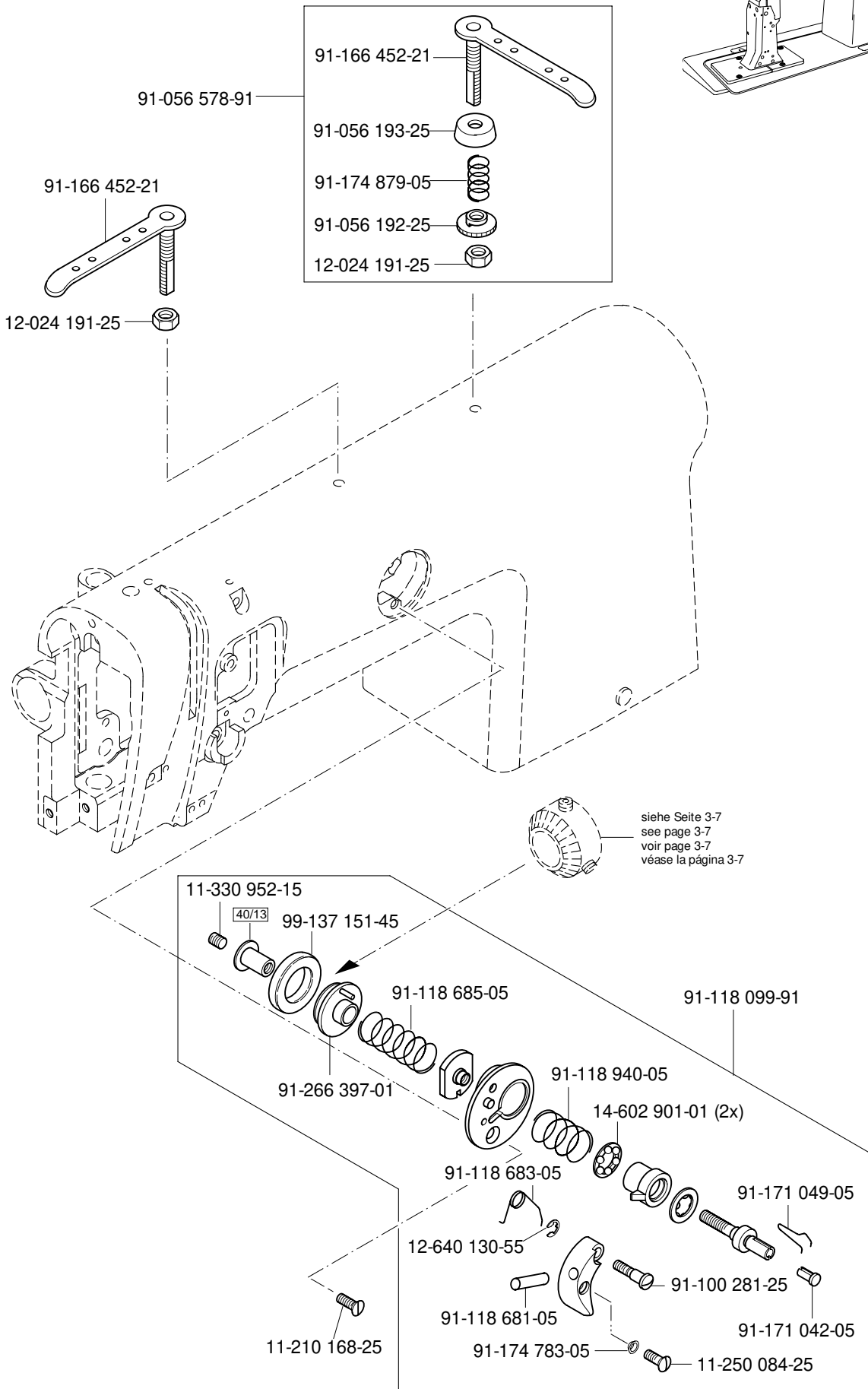
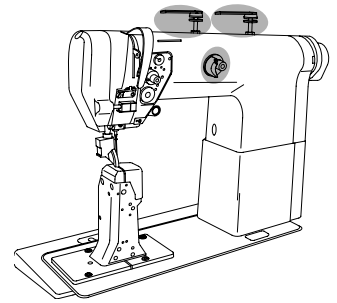

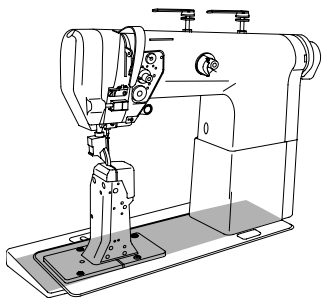

Grundplattenteile

Bedplate parts

Pièces du plateau fondamental

Piezas del cárter

PFAFF 471

PFAFF 474

PFAFF 491

3.04

siehe Seite 3-8
see page 3-8
voir page 3-8
véase la página 3-8

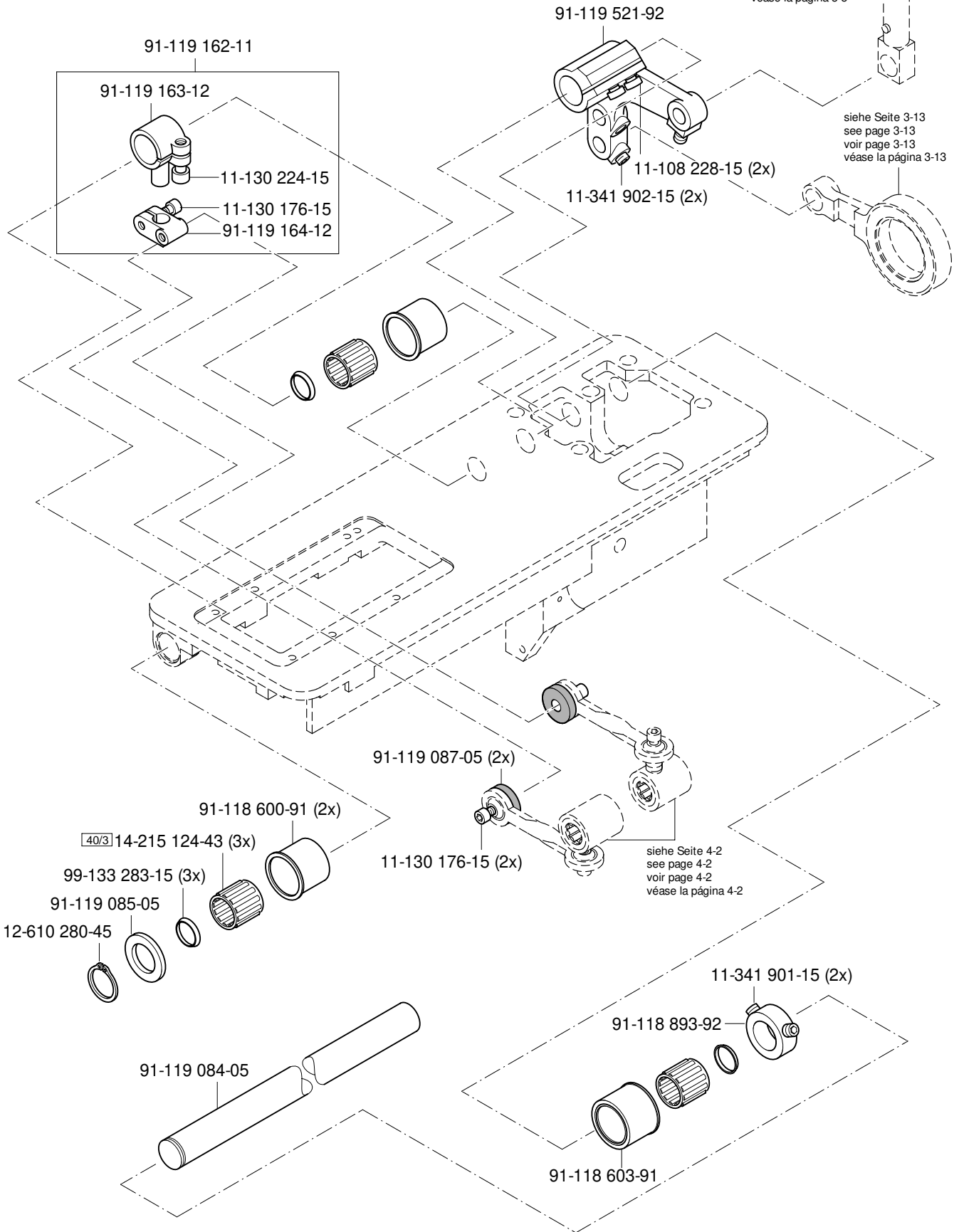

3.04

Grundplattenteile
 Bedplate parts
 Pièces du plateau fondamental
 Piezas del cárter

PFAFF 471
 PFAFF 474
 PFAFF 491

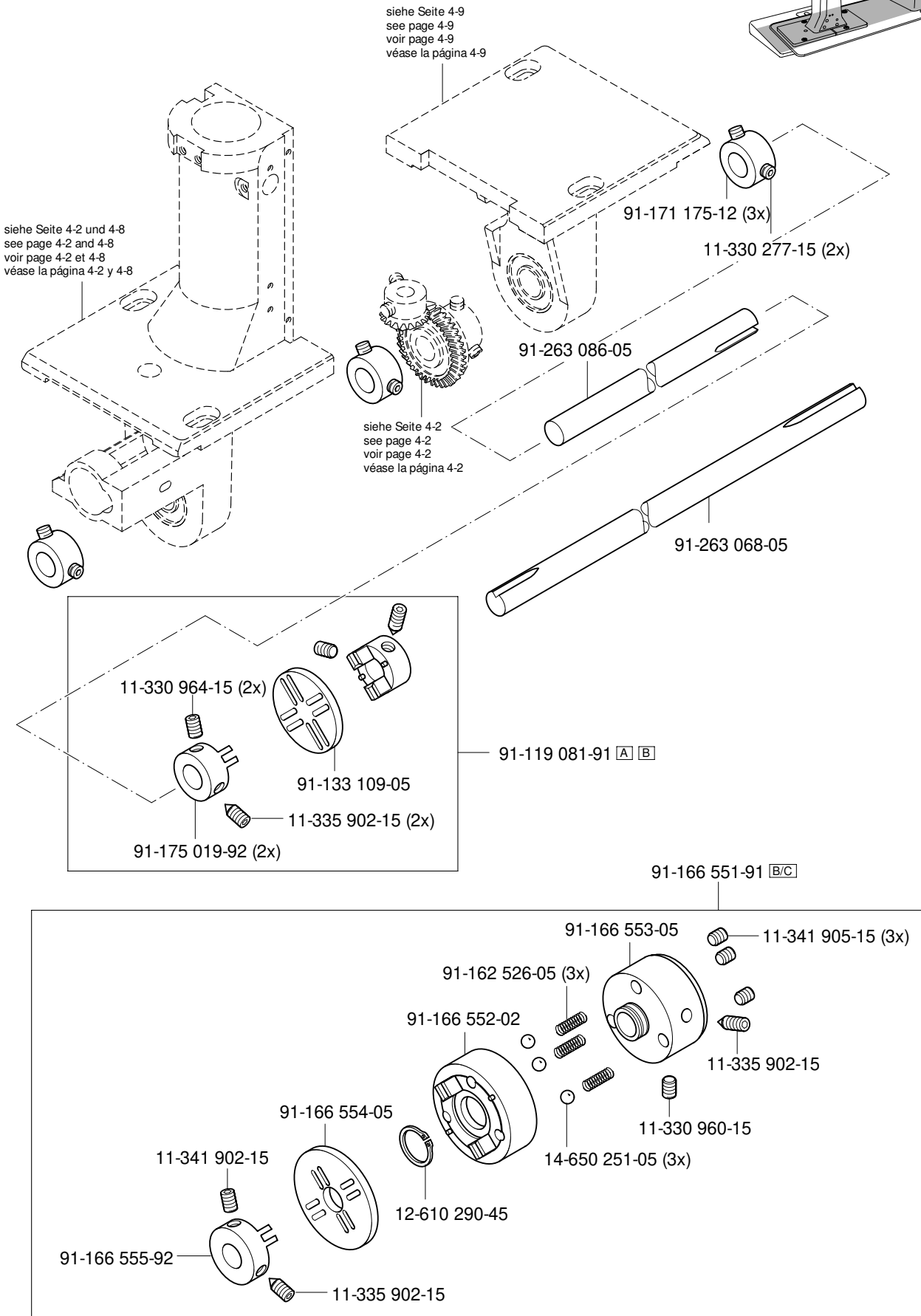
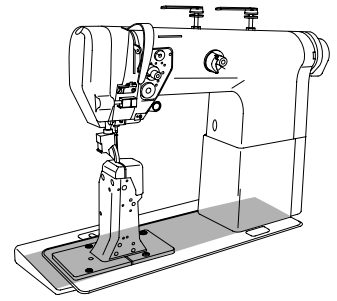

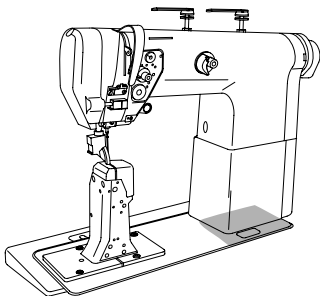

Grundplattenteile

Bedplate parts

Pièces du plateau fondamental

Piezas del cárter

PFAFF 471

PFAFF 474

PFAFF 491

3.04

siehe Seite 3-12
see page 3-12
voir page 3-12
véase la pagina 3-12

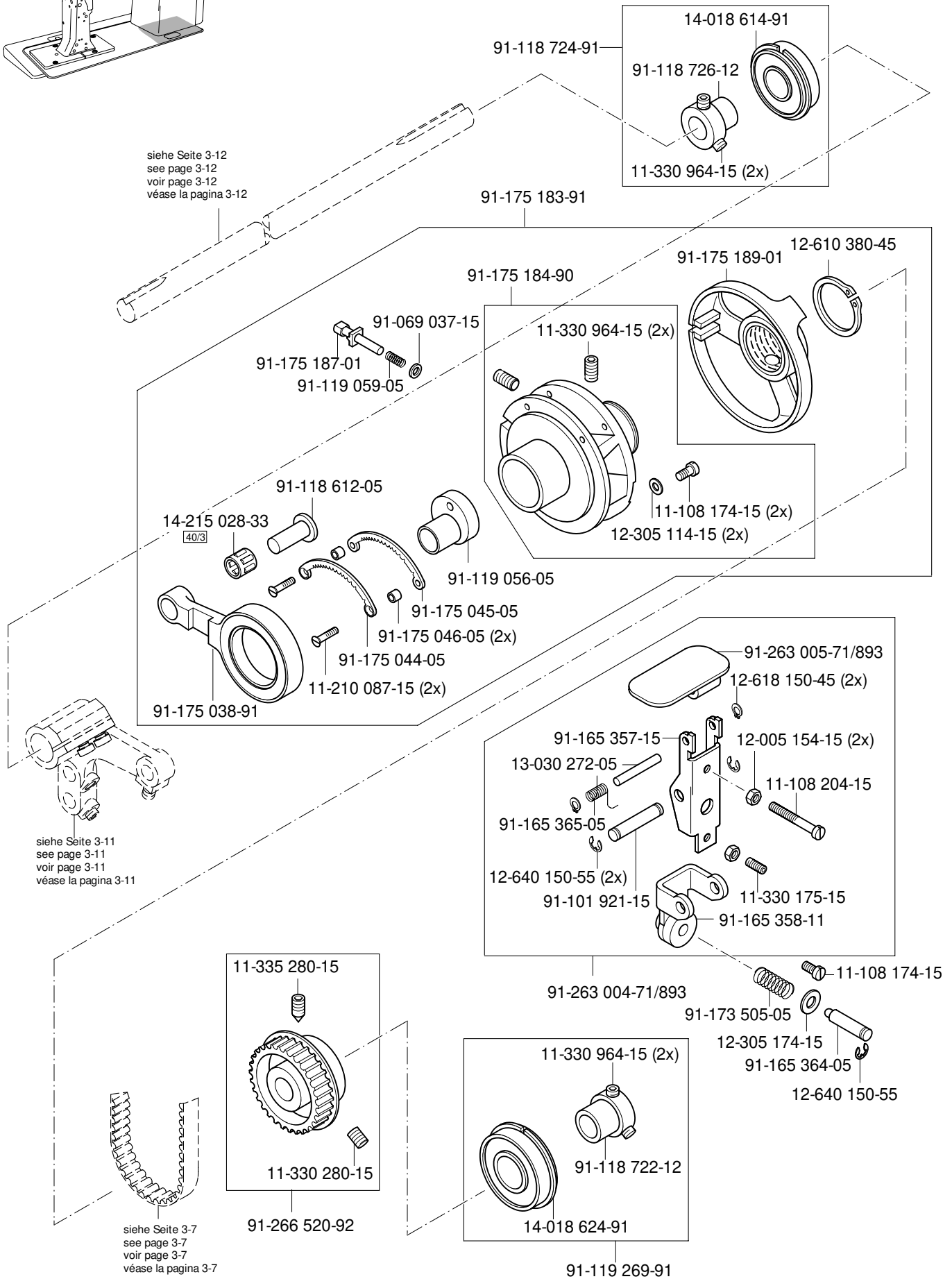

siehe Seite 3-11
see page 3-11
voir page 3-11
véase la pagina 3-11

siehe Seite 3-7
see page 3-7
voir page 3-7
véase la pagina 3-7

4.01

Greifersäule, links
 Hook post, left
 Pilier à crochet, gauche
 Columna del garfio, a la izquierda

PFAFF 471
 PFAFF 474

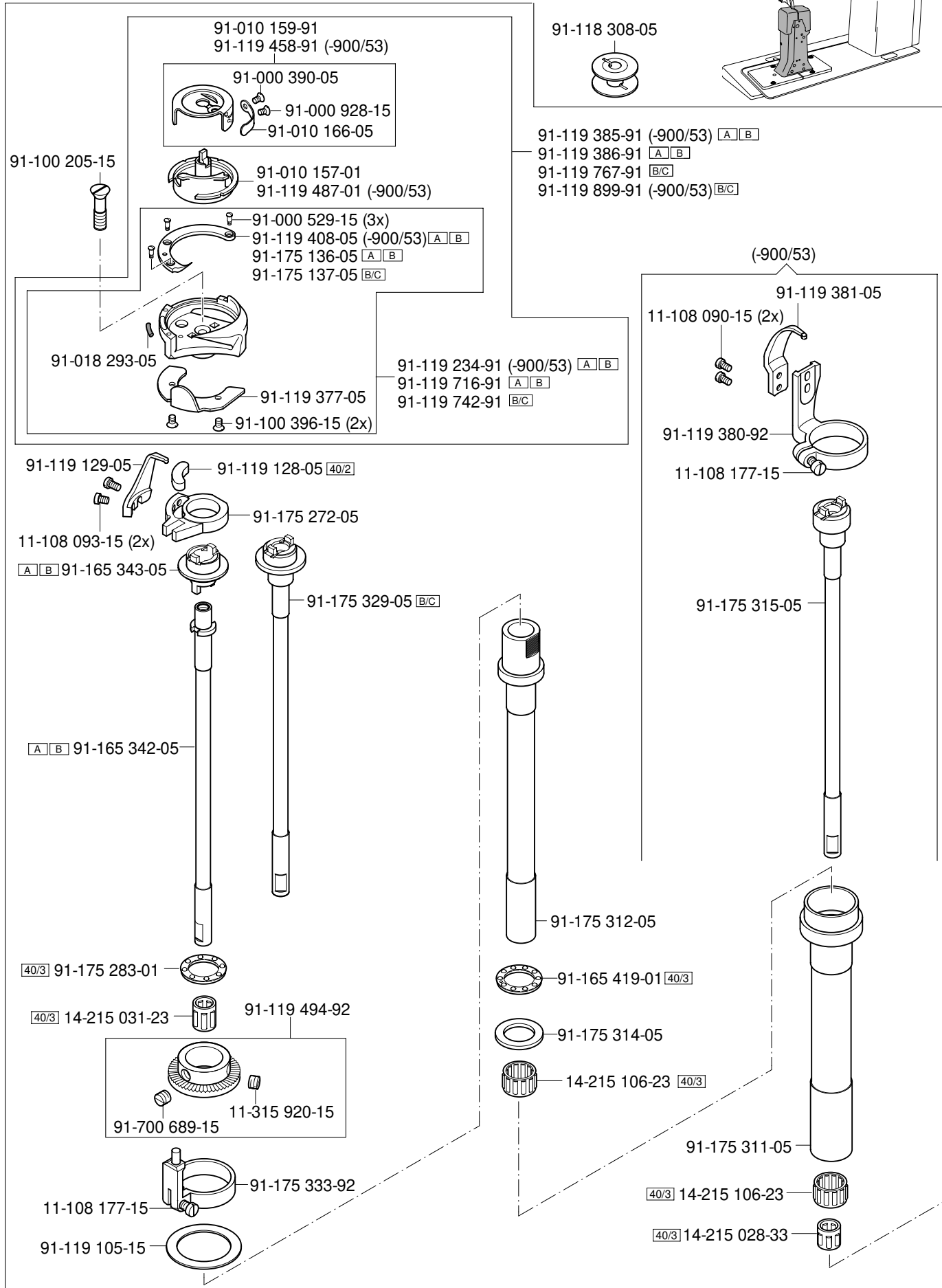
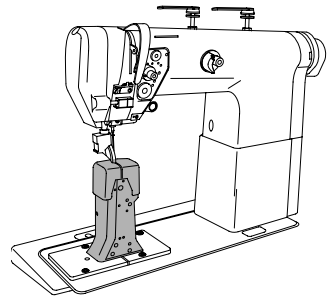

Greifersäule, links
 Hook post, left
 Pilier à crochet, gauche
 Columna del garfio, a la izquierda

PFAFF 471
 PFAFF 474

4.01

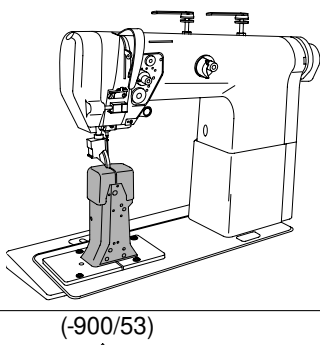

(-900/53)

91-119 492-91
 (-900/53)

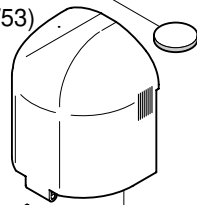

- 91-263 050-71/895 (PFAFF 471; 471-725) [A] [B]
- 91-263 052-71/895 (PFAFF 471-725 -900; 471-900) [A] [B]
- 91-263 053-71/895 (PFAFF 474; 474-725) [A] [B]
- 91-263 054-71/895 (PFAFF 474) [B/C]
- 91-263 055-71/895 (PFAFF 474-900; 474-725 -900) [A] [B]
- 91-263 056-71/895 (PFAFF 474-900) [B/C]
- 91-263 081-71/895 (PFAFF 471-725 -900 -911; 471-900 -911) [A] [B]
- 91-263 083-71/895 (PFAFF 474-900 -911) [B/C]

12-024 121-25
 11-330 094-15

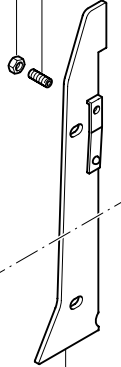

13-070 103-05

91-119 142-25

11-174 170-15 (2x)

11-174 170-15

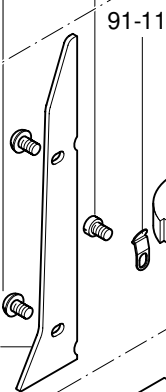

91-119 141-25 (PFAFF 474)
 91-119 437-25 (PFAFF 471)
 91-119 733-25 (PFAFF 471-900; 474-900)

91-119 140-91 (PFAFF 474)
 91-119 436-91 (PFAFF 471)
 91-119 770-91 (PFAFF 471-900; 474-900)

91-119 143-05

91-175 321-05

siehe Seite 3-11
 see page 3-11
 voir page 3-11
 véase la página 3-11

91-100 381-15

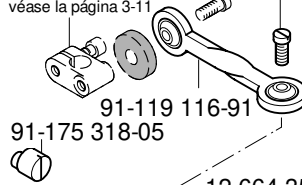

91-119 116-91
 91-175 318-05

91-119 111-05

12-664 350-45

14-012 555-01

91-119 115-01

91-119 112-01

91-263 113-90

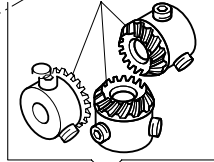

(-911/35)

(-900/53)

91-165 417-01 [40/3]

91-175 313-05

14-215 202-33 [40/3]

91-175 310-05

12-517 370-45

(PFAFF 474)

12-005 154-15

11-343 176-15

91-700 335-25 (4x)

91-164 183-75/895

91-164 682-91 (-900/53)

11-330 085-15

siehe Seite 4-9
 see page 4-9
 voir page 4-9
 véase la página 4-9

91-164 683-05

91-119 279-15

12-640 070-55
 (2x)

91-119 749-05

91-119 281-92 (-900/53)

siehe Seite 7-2
 see page 7-2
 voir page 7-2
 véase la página 7-2

11-174 179-15

91-122 718-05 (0,1 mm)

91-125 008-05 (0,15 mm)

91-125 009-05 (0,2 mm)

11-341 901-15 (2x)

91-119 133-90 [40/4]

(-900/53)

91-119 271-92

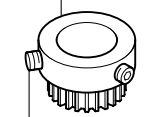

11-330 964-15 (2x)

[40/2] 91-119 103-05

12-664 390-45

[40/3] 91-175 138-01

91-119 107-92

11-330 964-15 (2x)

91-119 950-05

91-119 390-05 (0,1 mm)

91-119 957-05 (0,15 mm)

91-119 958-05 (0,2 mm)

[40/4] 91-119 109-90

(4x) 11-330 964-15

11-178 175-15 11-341 905-15 (2x)

4.02

Greifersäule, rechts
 Hook post, right
 Pilier à crochet, droit
 Columna del garfio, a la derecha

PFAFF 474
 PFAFF 491

91-118 308-05

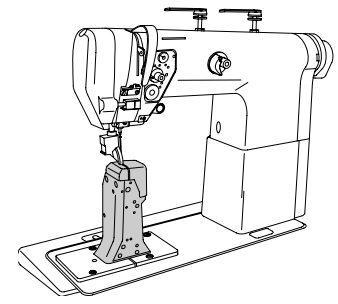

91-119 385-91 (-900/53) [A][B]
 91-119 386-91 [A][B]
 91-119 767-91 [B/C]
 91-119 899-91 (-900/53)[B/C]

91-100 205-15



91-010 159-91
 91-119 458-91 (-900/53)

91-000 390-05



91-000 928-15
 91-010 166-05

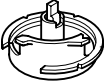

91-010 157-01
 91-119 487-01 (-900/53)

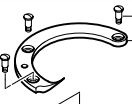

91-000 529-15 (3x)
 91-119 408-05 (-900/53) [A][B]
 91-175 136-05 [A][B]
 91-175 137-05 [B/C]

91-018 293-05

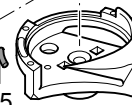

91-119 377-05
 91-100 396-15 (2x)

91-119 234-91 (-900/53) [A][B]
 91-119 716-91 [A][B]
 91-119 742-91 [B/C]

(-900/53)

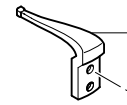

91-119 381-05

91-119 380-92

11-108 177-15



11-108 090-15
 (2x)

91-175 315-05



91-119 128-05 [40/2]

91-119 129-05

91-119 272-05

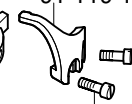
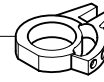

[A][B] 91-165 343-05

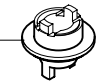

11-108 093-15 (2x)



91-175 329-05

91-175 325-05

[A][B] 91-165 342-05

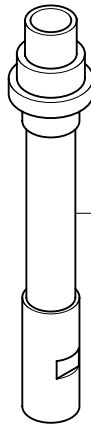
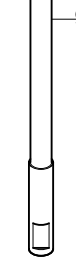
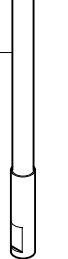

[40/3] 91-175 283-01



[40/3] 14-215 031-23



11-108 177-15



91-175 333-92



91-119 105-15



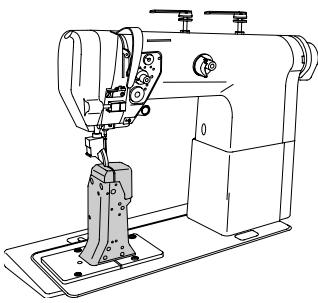

Greifersäule, rechts
 Hook post, right
 Pilier à crochet, droit
 Columna del garfio, a la derecha

PFAFF 474
 PFAFF 491

4.02

91-119 140-91 (PFAFF 474)
 91-119 436-91 (PFAFF 491)
 91-119 770-91 (PFAFF 474-900)
 91-175 225-91 (PFAFF 491-900)

[A] [B] 91-263 021-71/895 (PFAFF 491; 491-726)
 [B/C] 91-263 023-71/895 (PFAFF 491)
 [B] 91-263 025-71/895 (PFAFF 491-726 -900; 491-900)
 [B/C] 91-263 073-71/895 (PFAFF 491-900 -911)
 [A] [B] 91-263 057-71/895 (PFAFF 474)
 [B/C] 91-263 058-71/895 (PFAFF 474)
 [A] [B] 91-263 059-71/895 (PFAFF 474-900)
 [B/C] 91-263 060-71/895 (PFAFF 474-900)

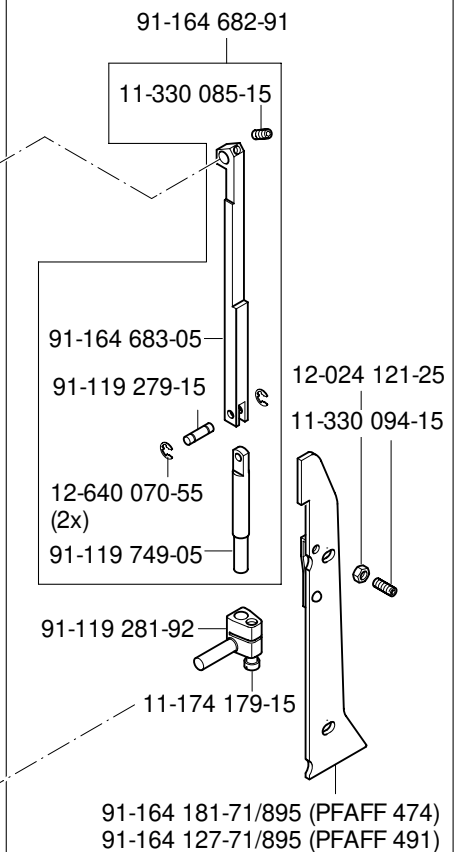
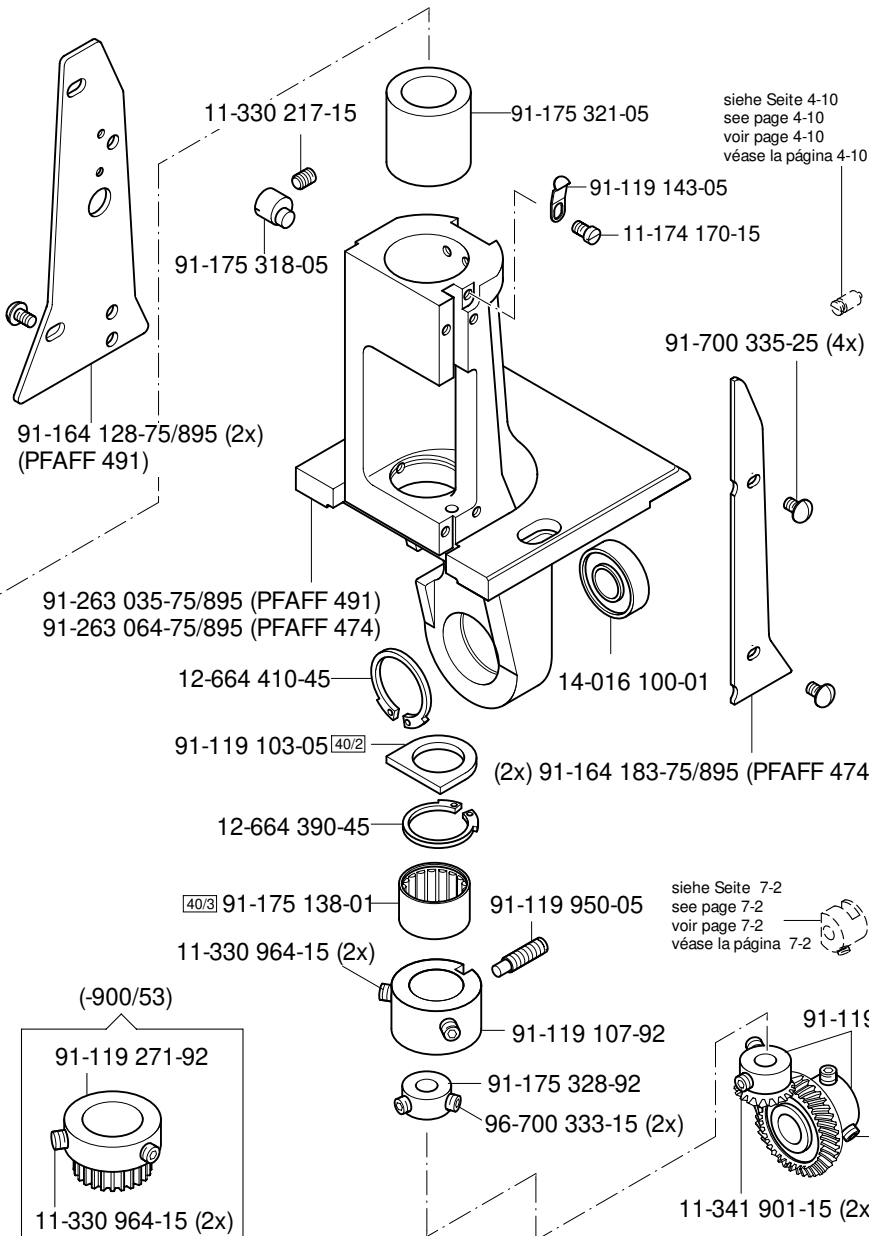
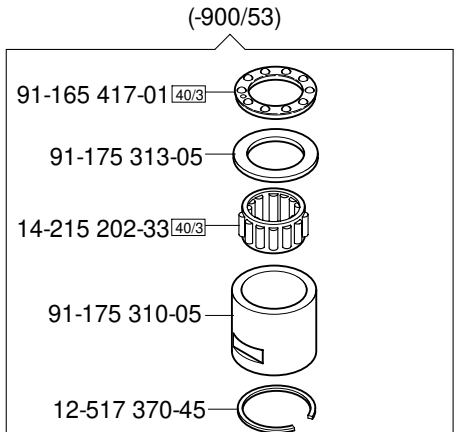
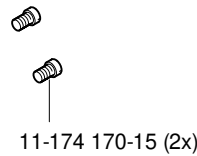
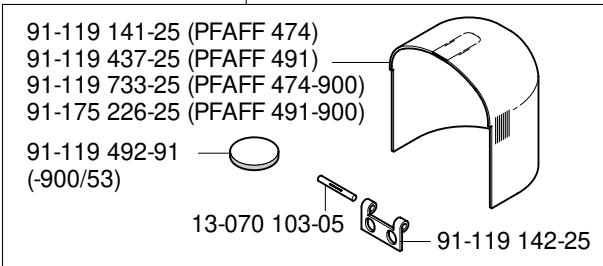

4.02

Greifersäule, rechts
 Hook post, right
 Pilier à crochet, droit
 Columna del garfio, a la derecha

PFAFF 474-725/04
 PFAFF 491-725/04

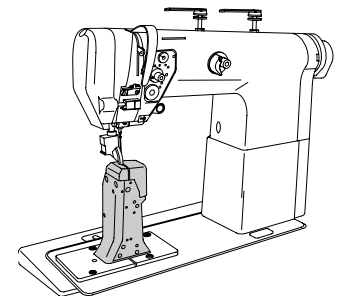

91-118 308-05



91-119 385-91 (-900/53) [A][B]
 91-119 386-91 [A][B]

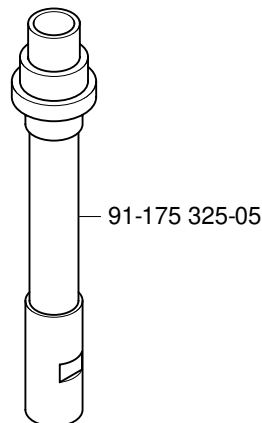
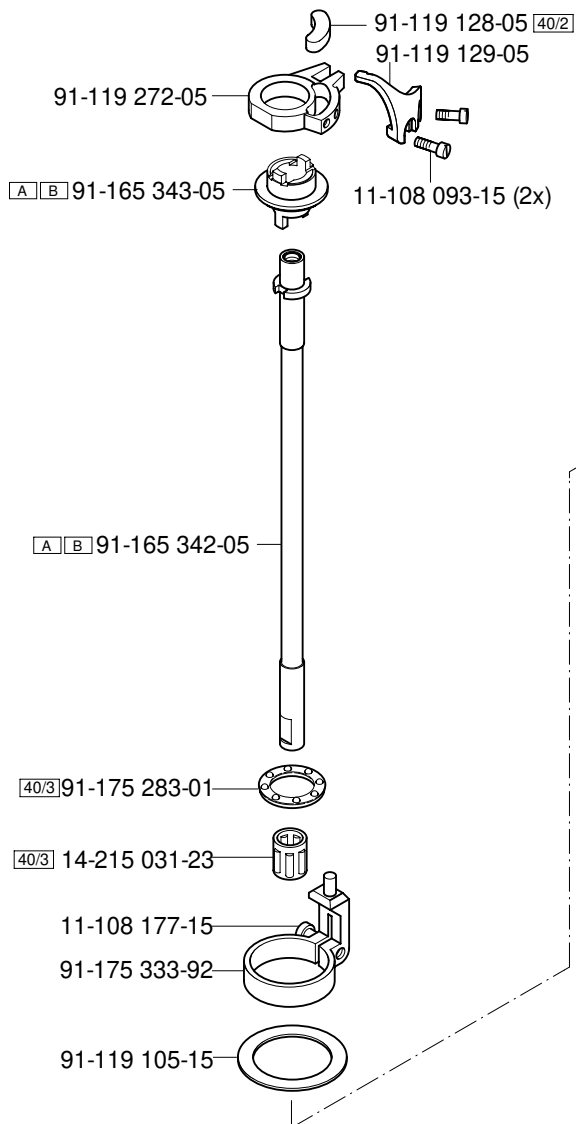
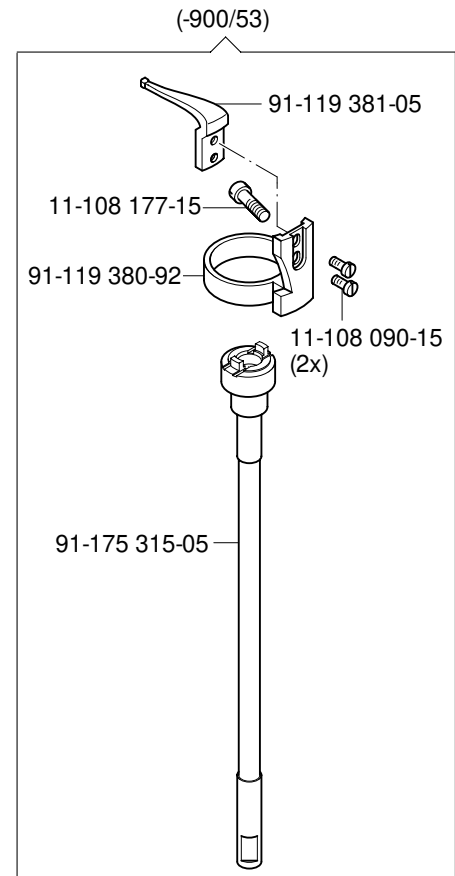
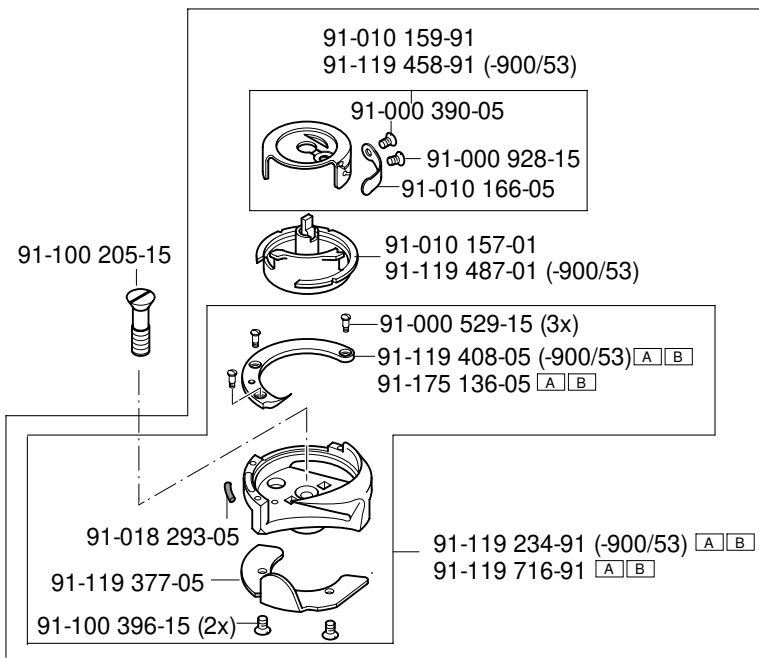

Greifersäule, rechts
 Hook post, right
 Pilier à crochet, droit
 Columna del garfio, a la derecha

PFAFF 474-725/04
 PFAFF 491-725/04

4.02

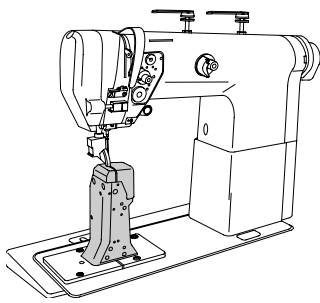

91-175 227-25 (PFAFF 474-900; 491-900)

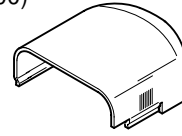
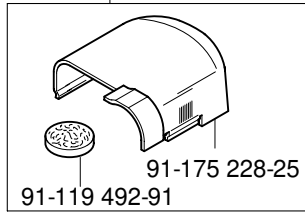

91-165 405-25 (PFAFF 474)
 91-119 605-25 (PFAFF 491)
 (-900/53)

91-175 337-71/895 (PFAFF 491-900/53)
 91-175 338-71/895 (PFAFF 474-900/53)

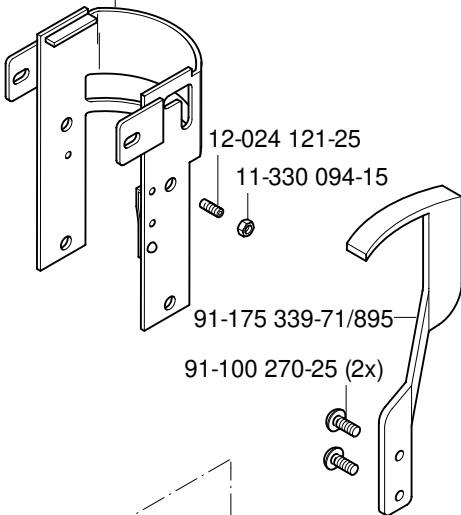

12-024 121-25
 11-330 094-15

91-175 335-71/895 (PFAFF 474)
 91-175 334-71/895 (PFAFF 491)

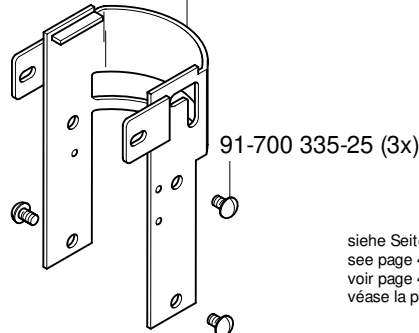

91-700 335-25 (3x)

siehe Seite 4-9
 see page 4-9
 voir page 4-9
 véase la página 4-9

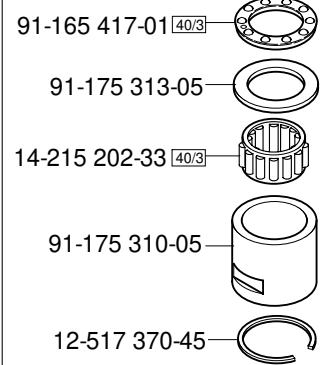

91-165 417-01 ^{40/3}

91-175 313-05

14-215 202-33 ^{40/3}

91-175 310-05

12-517 370-45

91-164 682-91

11-330 085-15

11-330 217-15 91-175 321-05

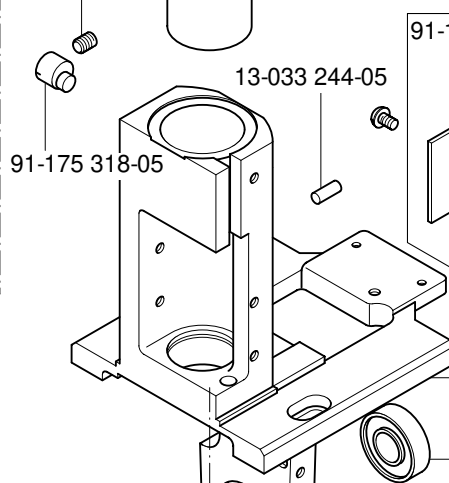

13-033 244-05

91-175 318-05

12-640 150-55 (2x)

91-119 607-15

12-305 174-15

91-119 671-05

91-119 938-71/895

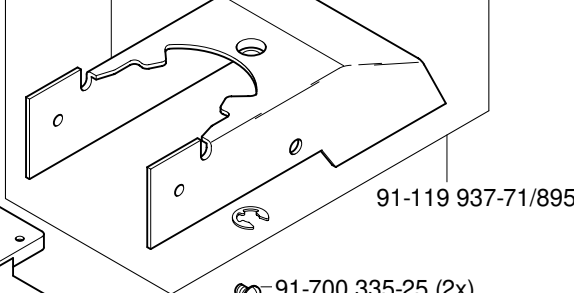

91-119 937-71/895

91-700 335-25 (2x)

91-263 036-75/895 (PFAFF 491)
 91-263 065-75/895 (PFAFF 474)

14-016 100-01

12-664 410-45

(-900/53)

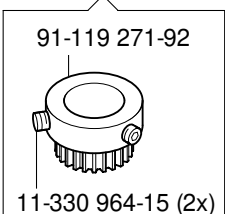

91-119 271-92

11-330 964-15 (2x)

^{40/3} 91-175 138-01 91-119 950-05

11-330 964-15 (2x)

91-119 107-92

91-119 107-92

siehe Seite 7-2
 see page 7-2
 voir page 7-2
 véase la página 7-2

91-119 281-92

11-174 179-15

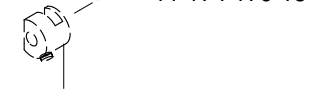

siehe Seite 7-2
 see page 7-2
 voir page 7-2
 véase la página 7-2

siehe Seite 7-2
 see page 7-2
 voir page 7-2
 véase la página 7-2

siehe Seite 7-2
 see page 7-2
 voir page 7-2
 véase la página 7-2

siehe Seite 7-2
 see page 7-2
 voir page 7-2
 véase la página 7-2

siehe Seite 7-2
 see page 7-2
 voir page 7-2
 véase la página 7-2

siehe Seite 7-2
 see page 7-2
 voir page 7-2
 véase la página 7-2

siehe Seite 7-2
 see page 7-2
 voir page 7-2
 véase la página 7-2

siehe Seite 7-2
 see page 7-2
 voir page 7-2
 véase la página 7-2

siehe Seite 7-2
 see page 7-2
 voir page 7-2
 véase la página 7-2

siehe Seite 7-2
 see page 7-2
 voir page 7-2
 véase la página 7-2

siehe Seite 7-2
 see page 7-2
 voir page 7-2
 véase la página 7-2

siehe Seite 7-2
 see page 7-2
 voir page 7-2
 véase la página 7-2

siehe Seite 7-2
 see page 7-2
 voir page 7-2
 véase la página 7-2

siehe Seite 7-2
 see page 7-2
 voir page 7-2
 véase la página 7-2

siehe Seite 7-2
 see page 7-2
 voir page 7-2
 véase la página 7-2

siehe Seite 7-2
 see page 7-2
 voir page 7-2
 véase la página 7-2

siehe Seite 7-2
 see page 7-2
 voir page 7-2
 véase la página 7-2

4.02

Greifersäule, rechts
Hook post, right
Pilier à crochet, droit
Columna del garfio, a la derecha

PFAFF 474-725/04
PFAFF 491-725/04

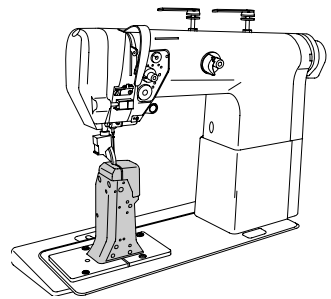

siehe Seite 5-3
see page 5-3
voir page 5-3
véase la página 5-3

- [B] 91-263 022-71/895 (PFAFF 491)
- [A] [B] 91-263 026-71/895 (PFAFF 491-900)
- [A] [B] 91-263 061-71/895 (PFAFF 474)
- [A] [B] 91-263 062-71/895 (PFAFF 474/900)

11-130 167-15 91-175 112-71/895

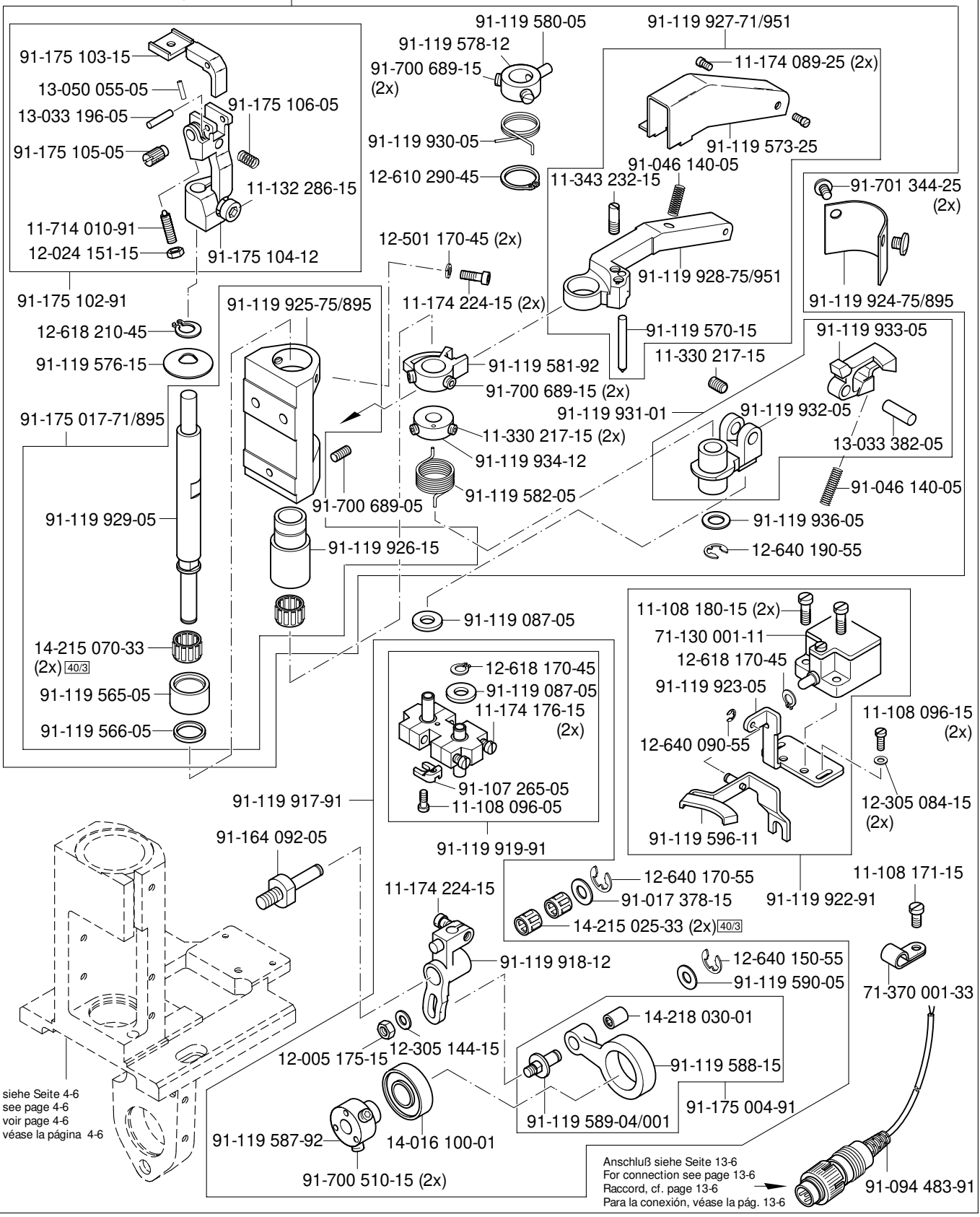

siehe Seite 4-6
see page 4-6
voir page 4-6
véase la página 4-6

Anschluß siehe Seite 13-6
For connection see page 13-6
Raccord, cf. page 13-6
Para la conexión, véase la pág. 13-6

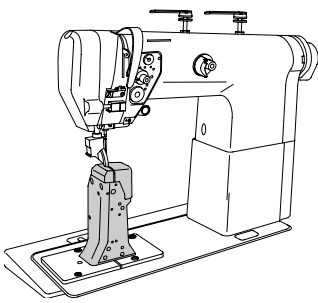

Schiebradsäule, links
 Feed wheel post, left
 Pilier à roue d'entraînement, gauche
 Columna del arrastre por rueda, a la izquierda PFAFF 491

4.03

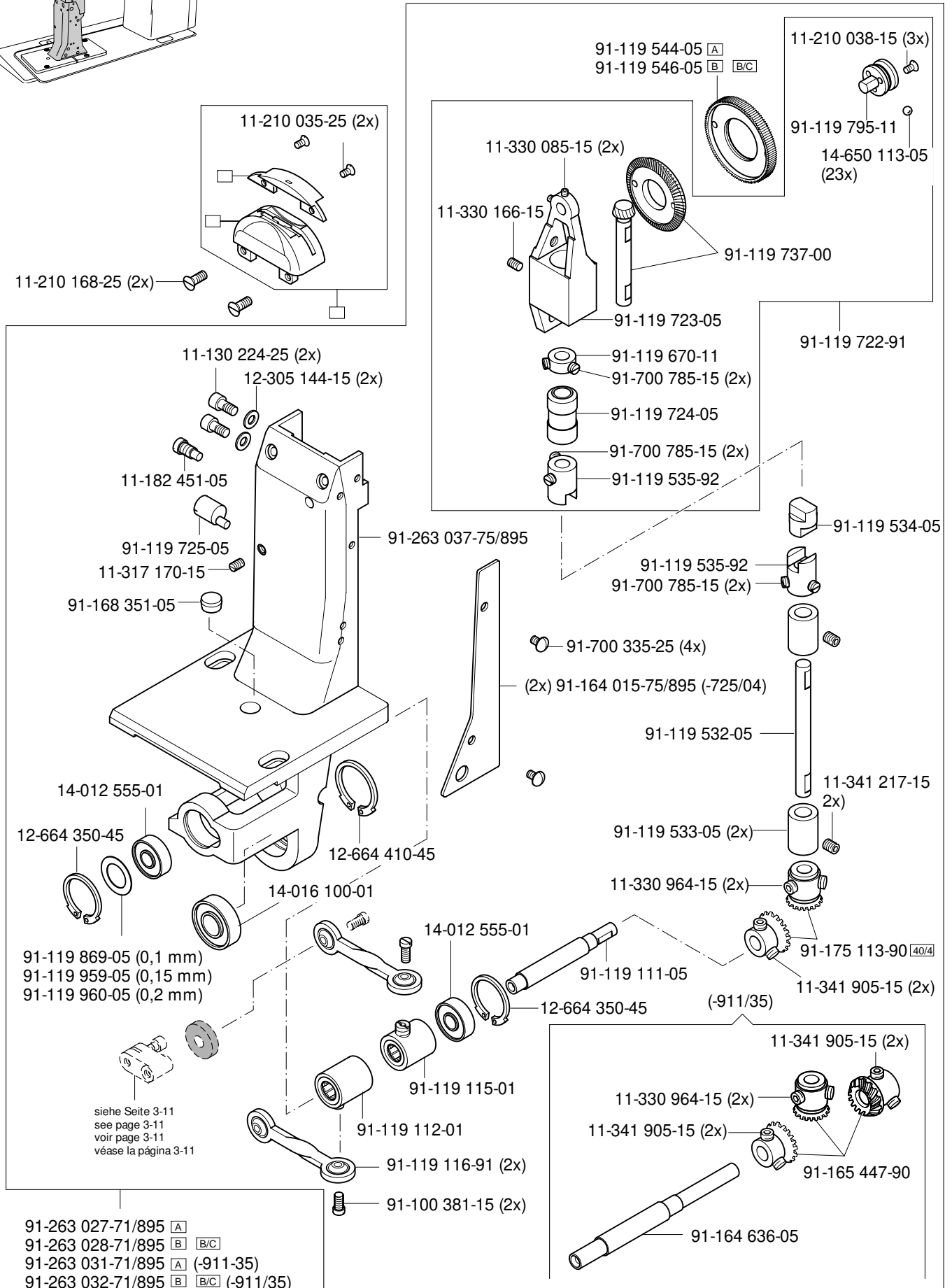

4.04

Schiebrad-Trägerplatte
 Feed wheel mounting plate
 Plaque support de la roue d'entraînement
 Placa soporte del arrastre por rueda

PFAFF 471

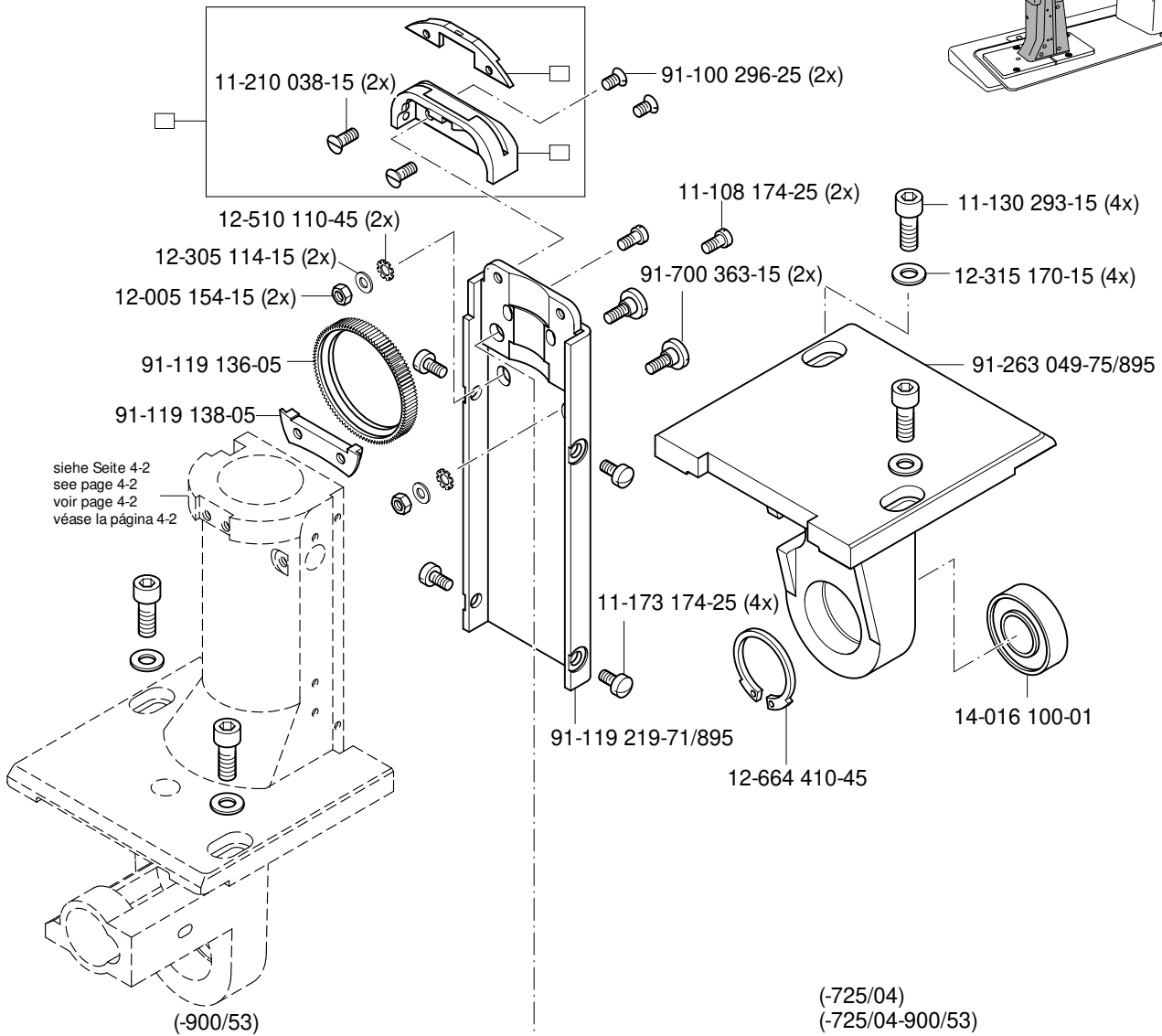
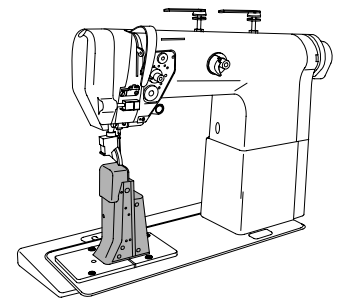

siehe Seite 4-2
 see page 4-2
 voir page 4-2
 véase la página 4-2

siehe Seite 5-1
 see page 5-1
 voir page 5-1
 véase la página 5-1

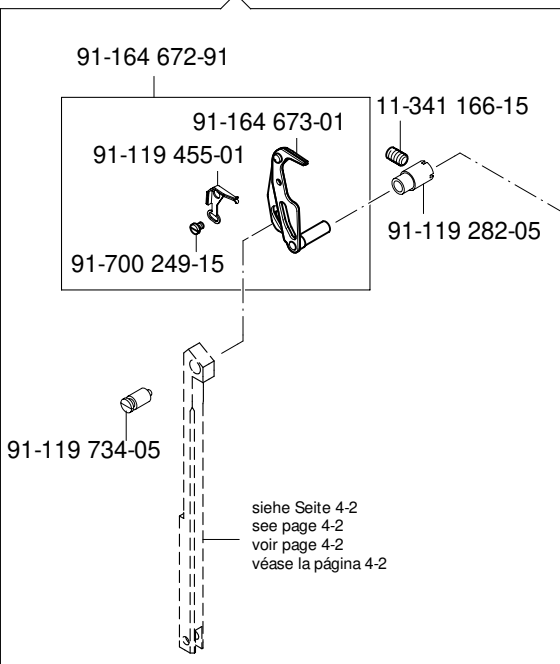

siehe Seite 4-2
 see page 4-2
 voir page 4-2
 véase la página 4-2

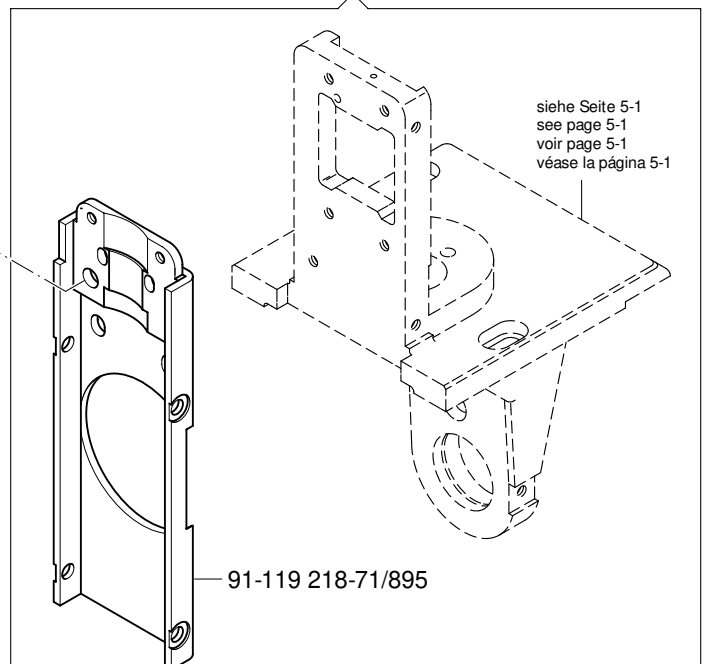

Schiebrad-Trägerplatte
 Feed wheel mounting plate
 Plaque support de la roue d'entraînement
 Placa soporte del arrastre por rueda

PFAFF 474

4.04

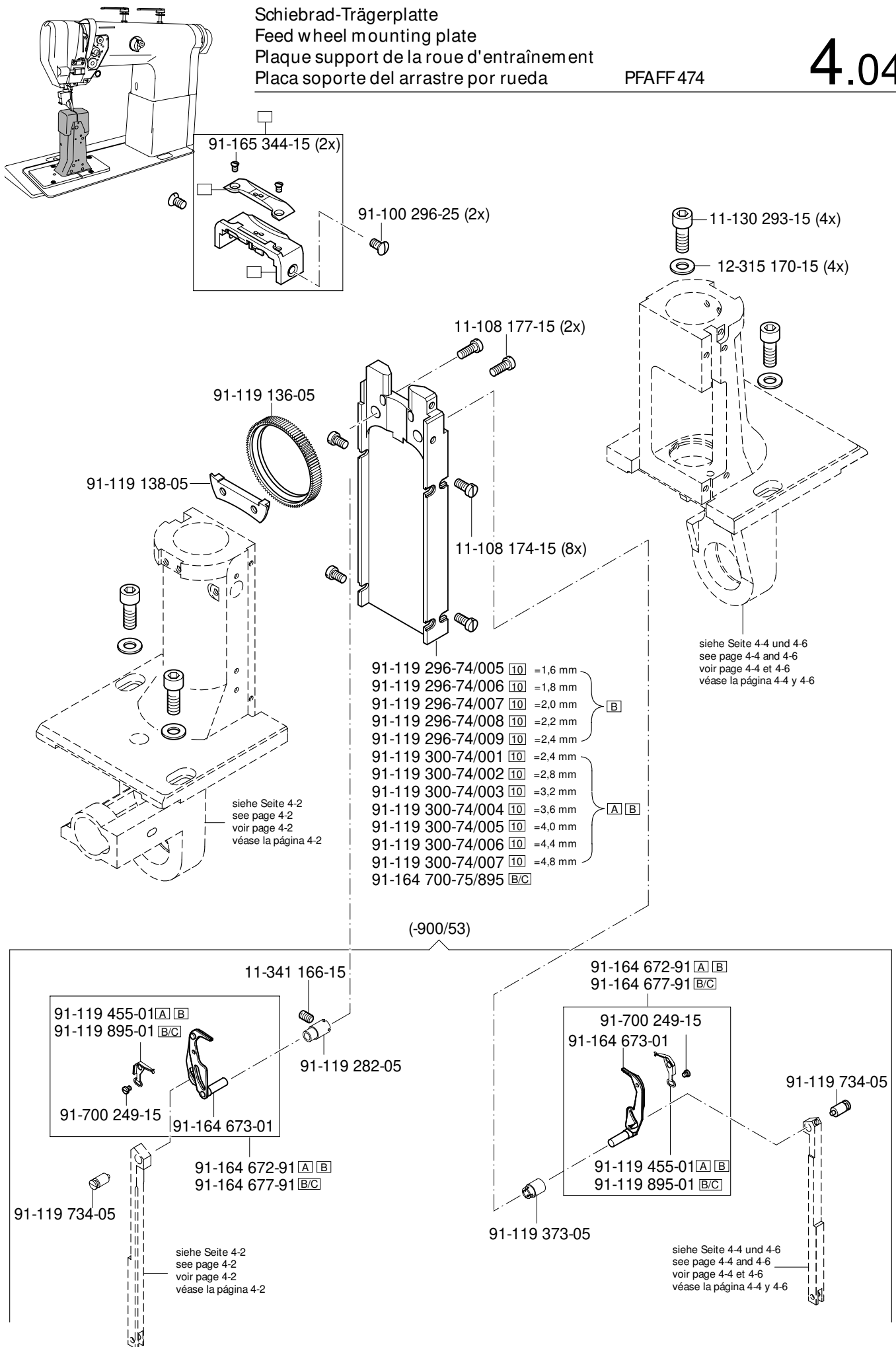

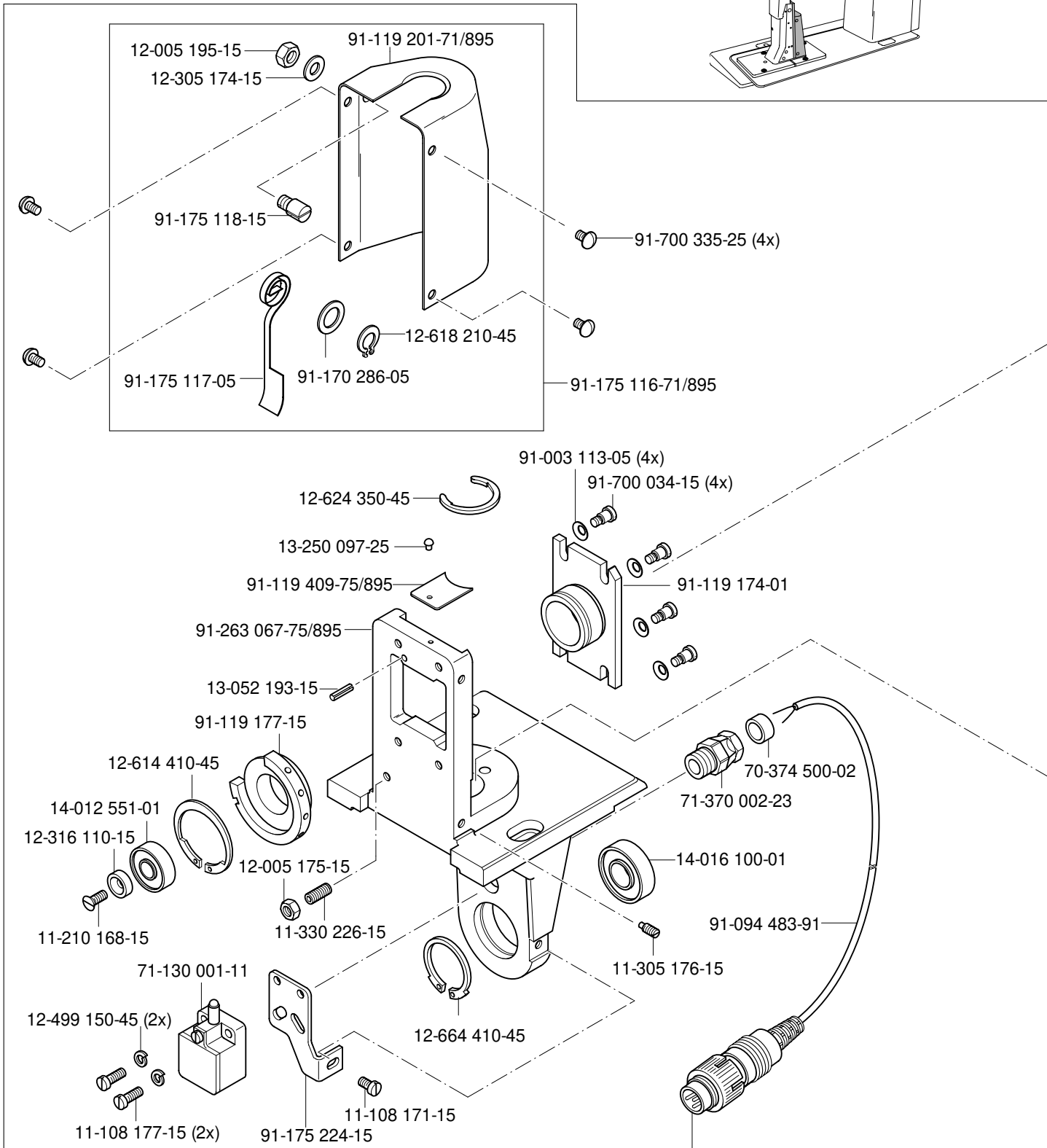
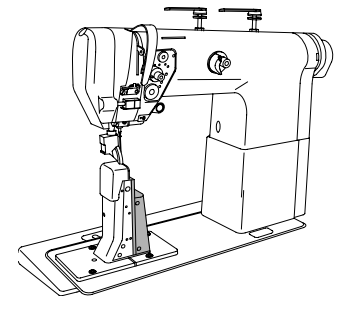

Anschluß siehe Seite 13-6
 For connection see page 13-6
 Raccord, cf. page 13-6
 Para la conexión, véase la pág. 13-6

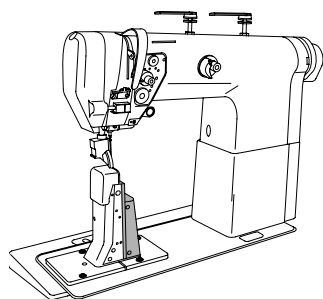

91-263 066-71/895

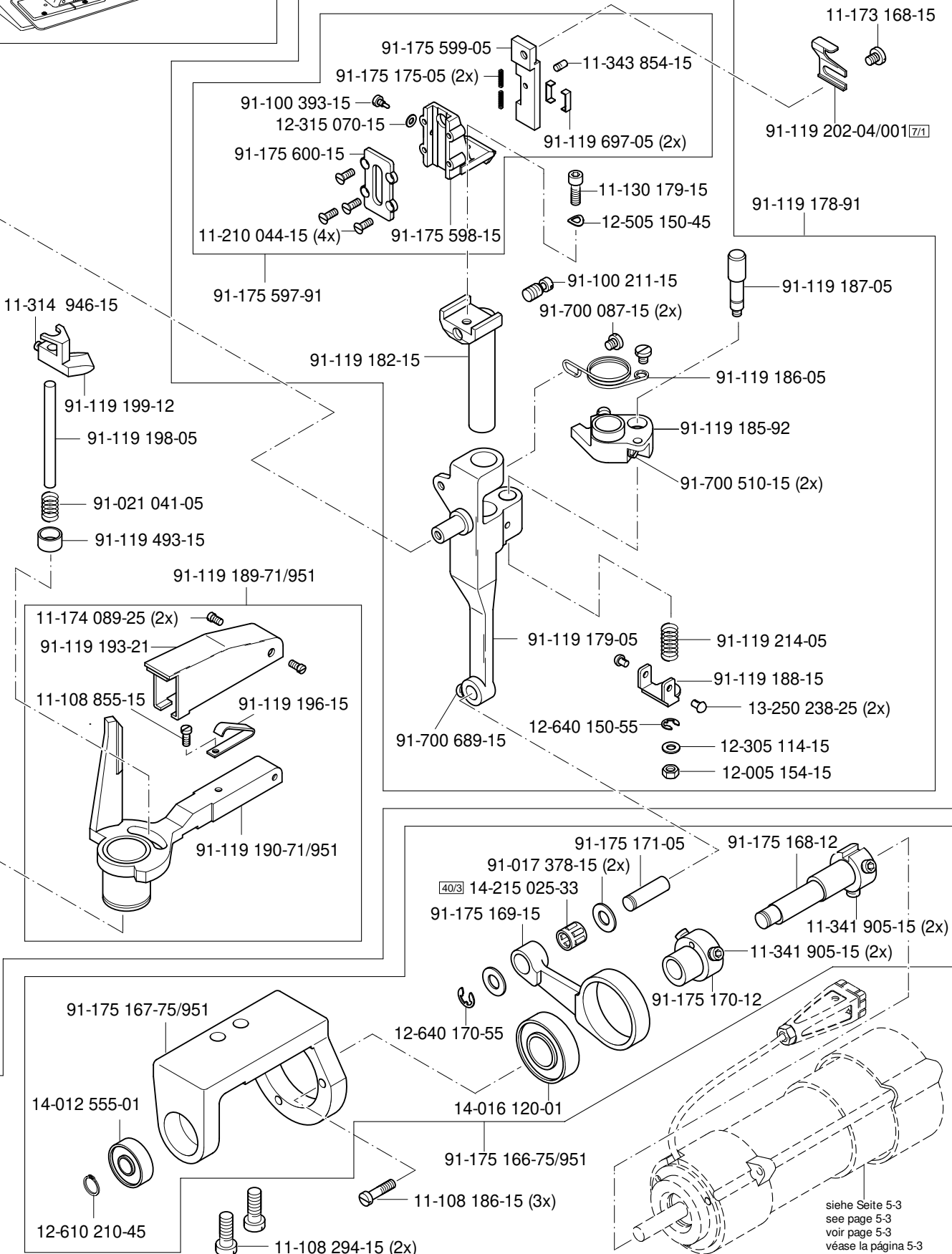

siehe Seite 5-3
 see page 5-3
 voir page 5-3
 véase la página 5-3

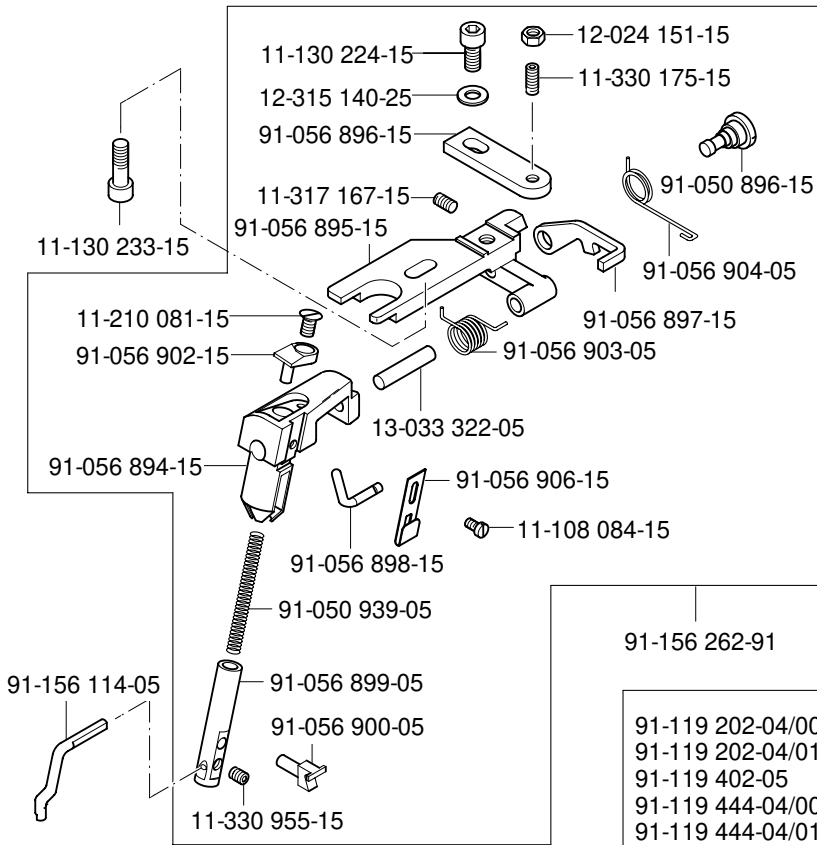
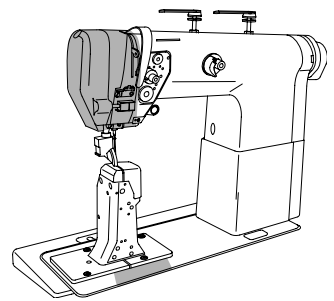

(PFAFF 474; PFAFF 491)

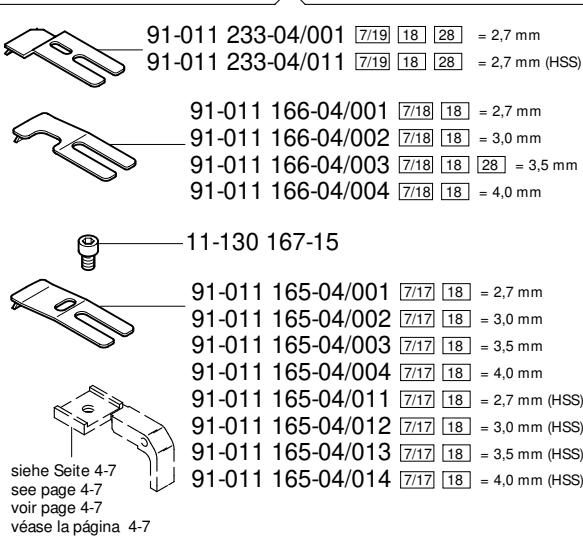

(PFAFF 471)

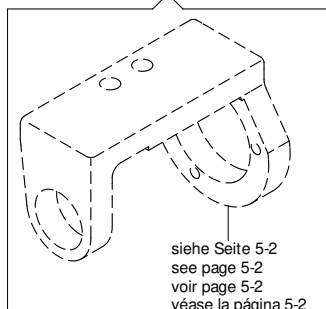

91-119 613-75/951
 (PFAFF 474; PFAFF 491)

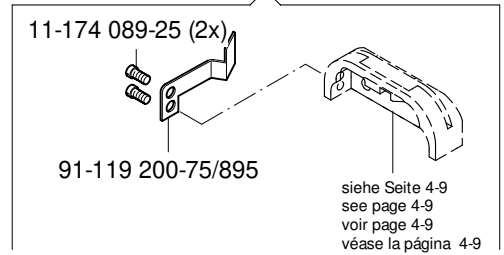
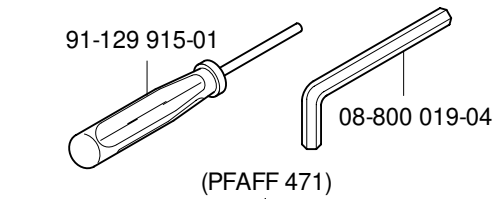
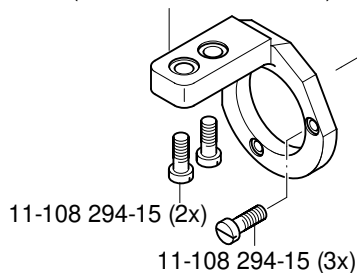

91-156 262-91

(PFAFF 471)

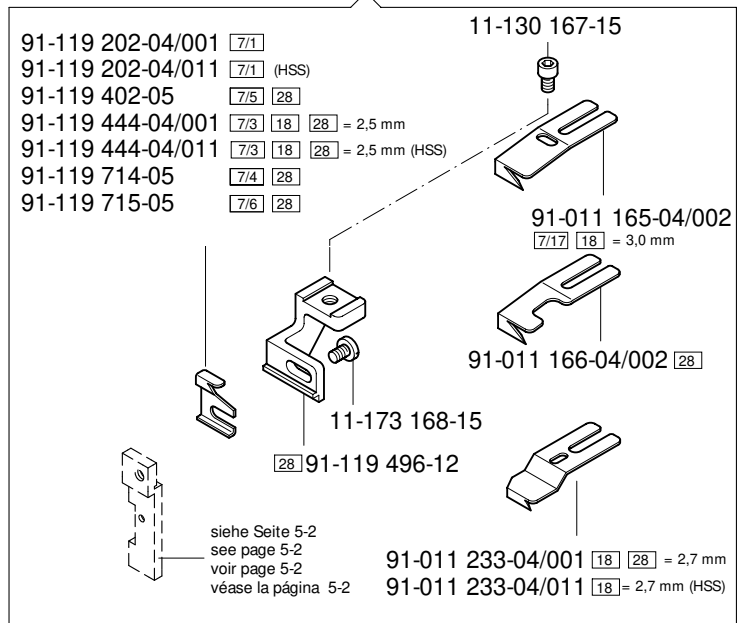

Anschluß siehe Seite 13-6
 For connection see page 13-6
 Raccord, cf. page 13-6
 Para la conexión, véase la pág. 13-6

71-370 001-35 (2x)

11-108 174-15 (2x)

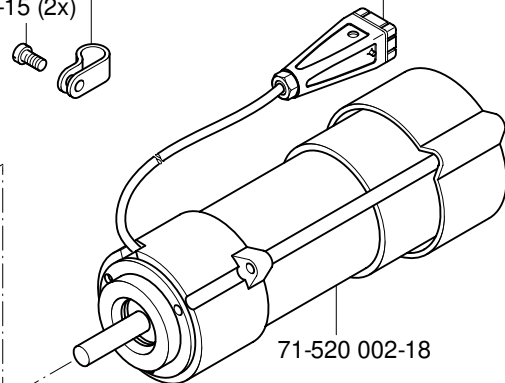

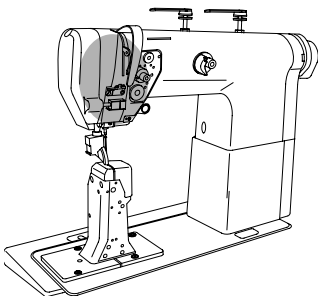

Kanten-Beschneideinrichtung (-726/05)
 Edge trimmer (-726/05)
 Couteau (-726/05)
 Recortador (-726/05)

PFAFF 491

6

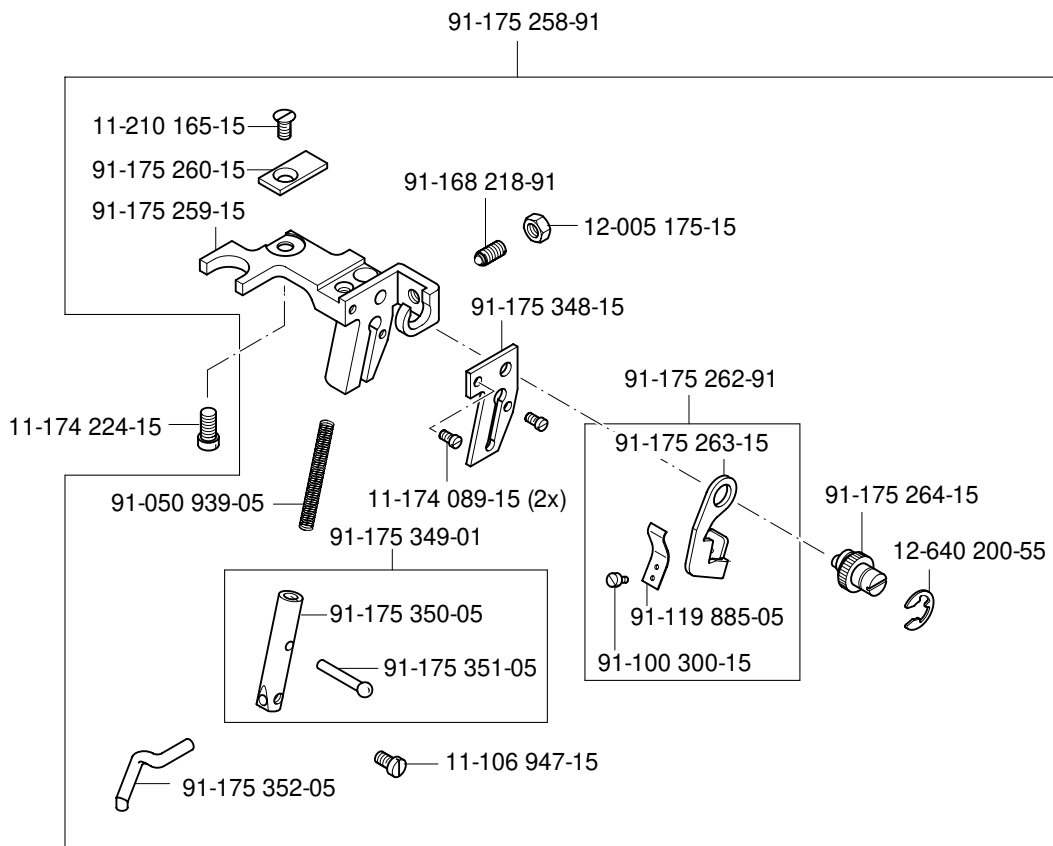

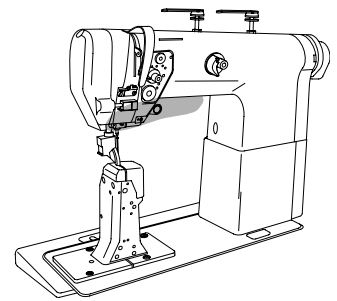

91-164 243-71/895

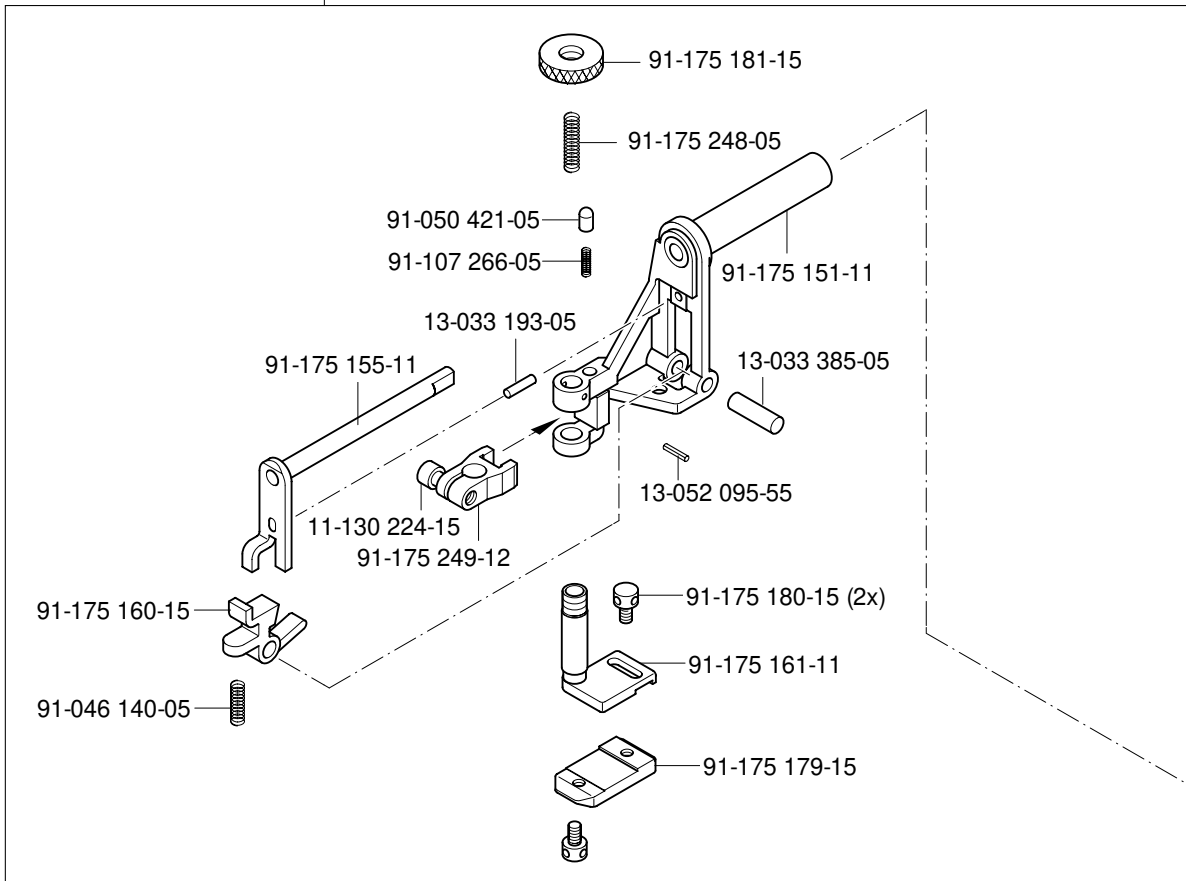

91-700 412-25

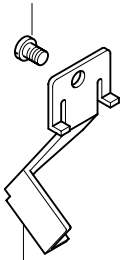

91-175 257-75/895

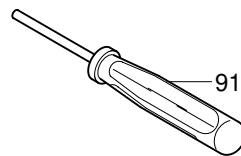

91-129 915-01

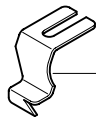

- 91-011 324-04/001 $\frac{7}{20}$ 18 = 2,7 mm
- 91-011 324-04/002 $\frac{7}{20}$ 18 = 3,0 mm
- 91-011 324-04/003 $\frac{7}{20}$ 18 = 3,5 mm
- 91-011 324-04/004 $\frac{7}{20}$ 18 = 4,0 mm
- 91-011 324-04/011 $\frac{7}{20}$ 18 = 2,7 mm (HSS)
- 91-011 324-04/012 $\frac{7}{20}$ 18 = 3,0 mm (HSS)
- 91-011 324-04/013 $\frac{7}{20}$ 18 = 3,5 mm (HSS)
- 91-011 324-04/014 $\frac{7}{20}$ 18 = 4,0 mm (HSS)

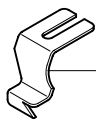

- 91-011 179-04/001 $\frac{7}{21}$ 18 = 2,7 mm
- 91-011 179-04/002 $\frac{7}{21}$ 18 = 3,0 mm
- 91-011 179-04/003 $\frac{7}{21}$ 18 = 3,5 mm
- 91-011 179-04/004 $\frac{7}{21}$ 18 = 4,0 mm
- 91-011 179-04/011 $\frac{7}{21}$ 18 = 2,7 mm (HSS)
- 91-011 179-04/012 $\frac{7}{21}$ 18 = 3,0 mm (HSS)
- 91-011 179-04/013 $\frac{7}{21}$ 18 = 3,5 mm (HSS)
- 91-011 179-04/014 $\frac{7}{21}$ 18 = 4,0 mm (HSS)

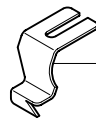

- 91-011 387-04/001 $\frac{7}{22}$ 18 = 2,7 mm
- 91-011 387-04/002 $\frac{7}{22}$ 18 = 3,0 mm
- 91-011 387-04/003 $\frac{7}{22}$ 18 = 3,5 mm
- 91-011 387-04/004 $\frac{7}{22}$ 18 = 4,0 mm

Kanten-Beschneideinrichtung (-726/05)
 Edge trimmer (-726/05)
 Couteau (-726/05)
 Recortador (-726/05)

PFAFF 491

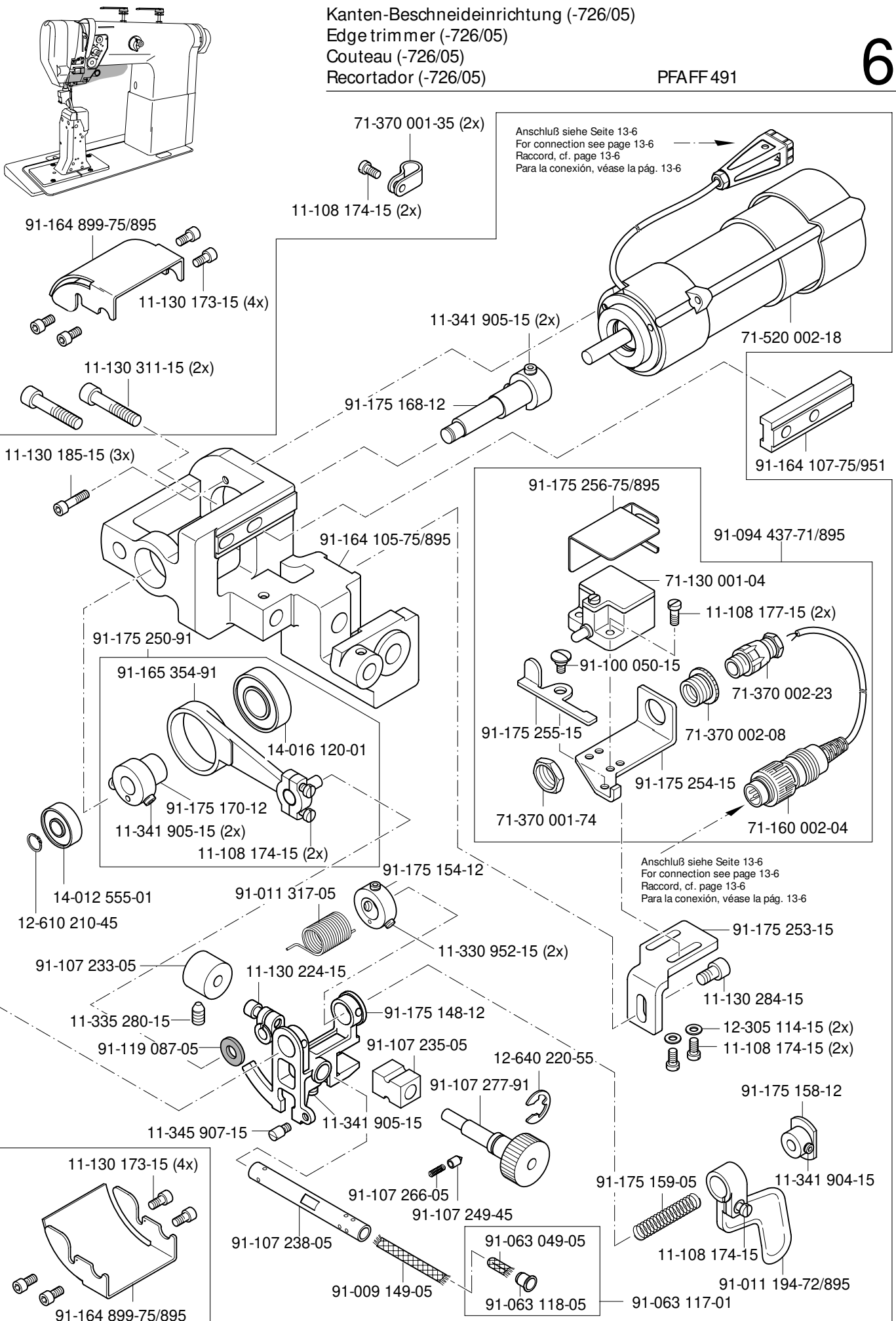

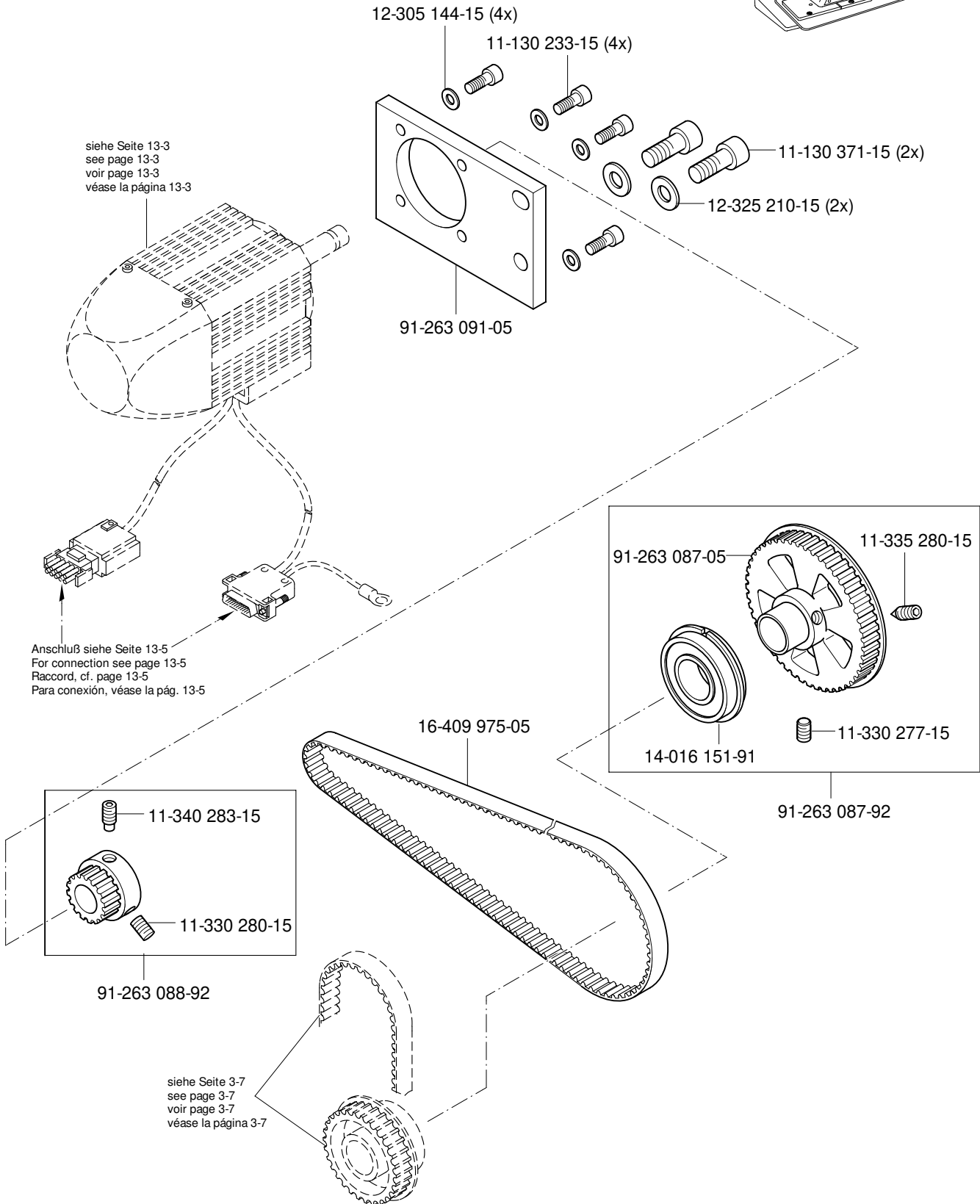
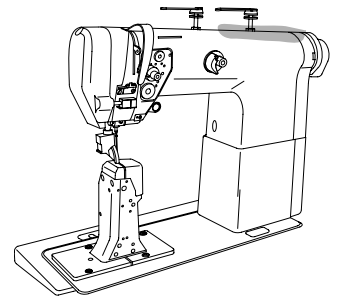

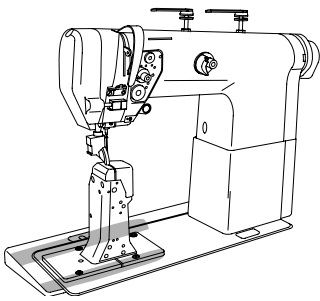

Fadenabschneid-Einrichtung (-900/53)
 Thread trimmer (-900/53)
 Coupe-fil (-900/53)
 Cortahilos (-900/53)

PFAFF 471
 PFAFF 474
 PFAFF 491

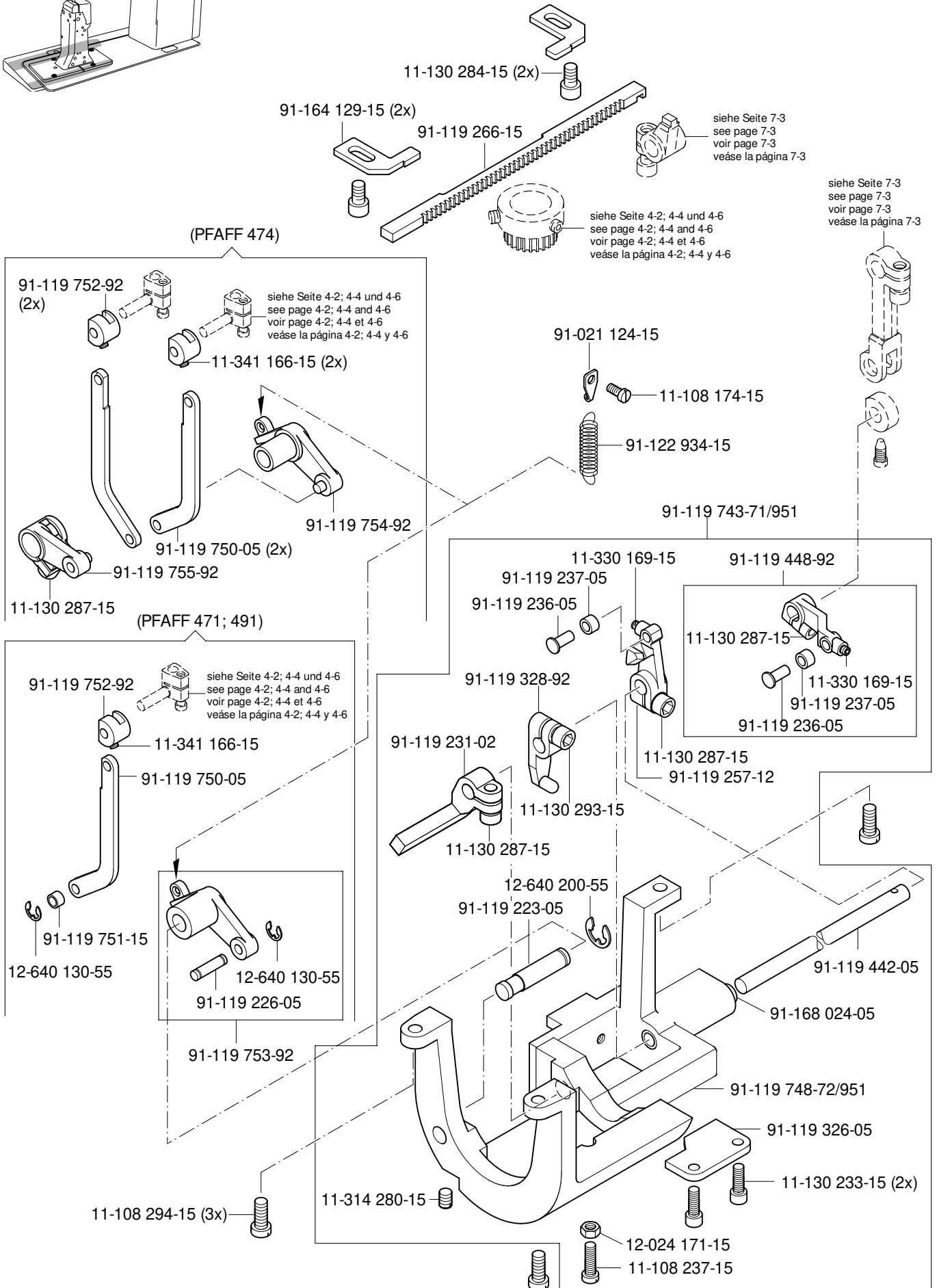

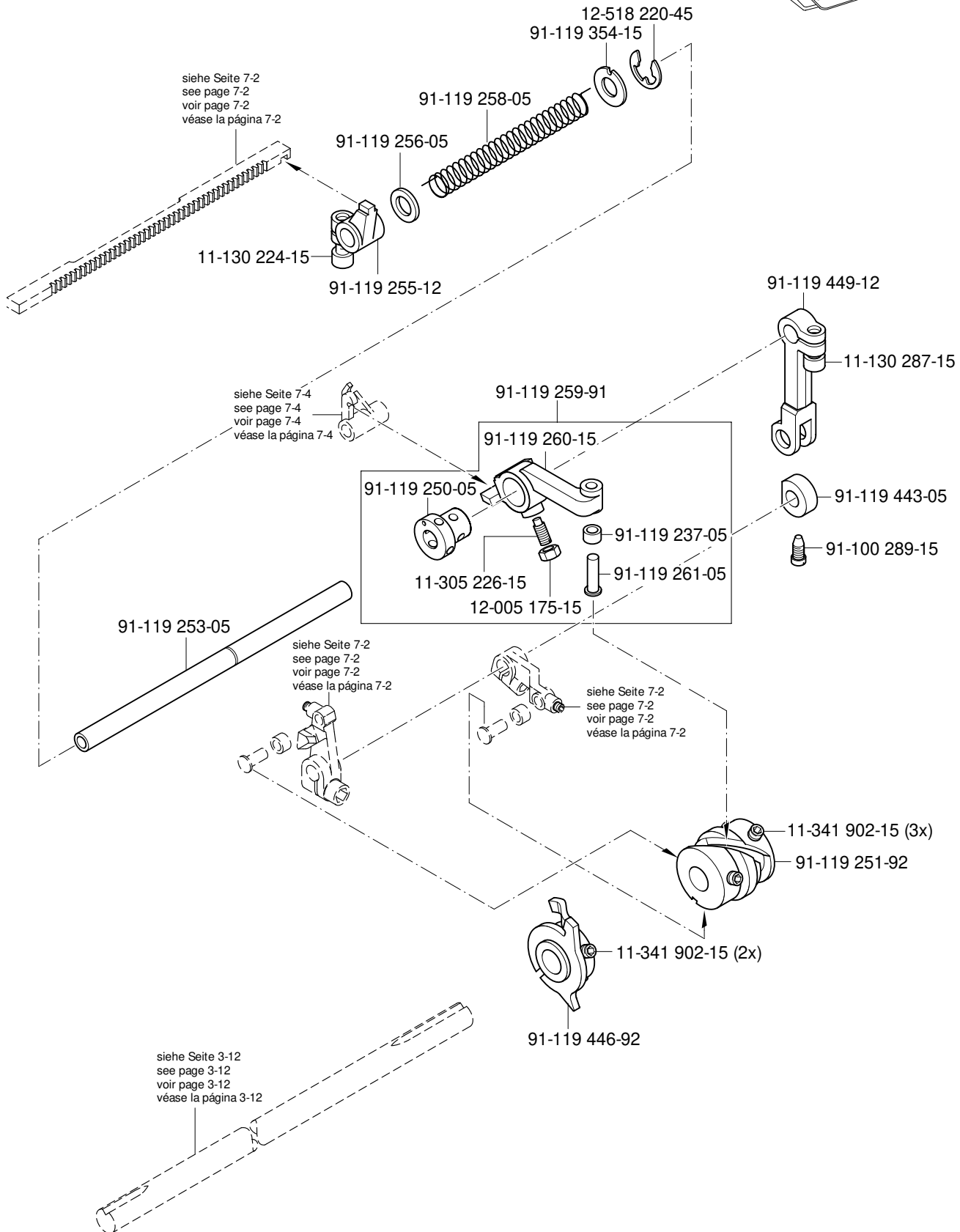
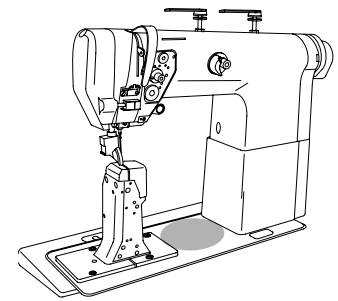

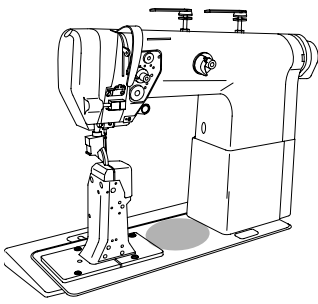

Fadenabschneid-Einrichtung (-900/53)
 Thread trimmer (-900/53)
 Coupe-fil (-900/53)
 Cortahilos (-900/53)

PFAFF 471
 PFAFF 474
 PFAFF 491

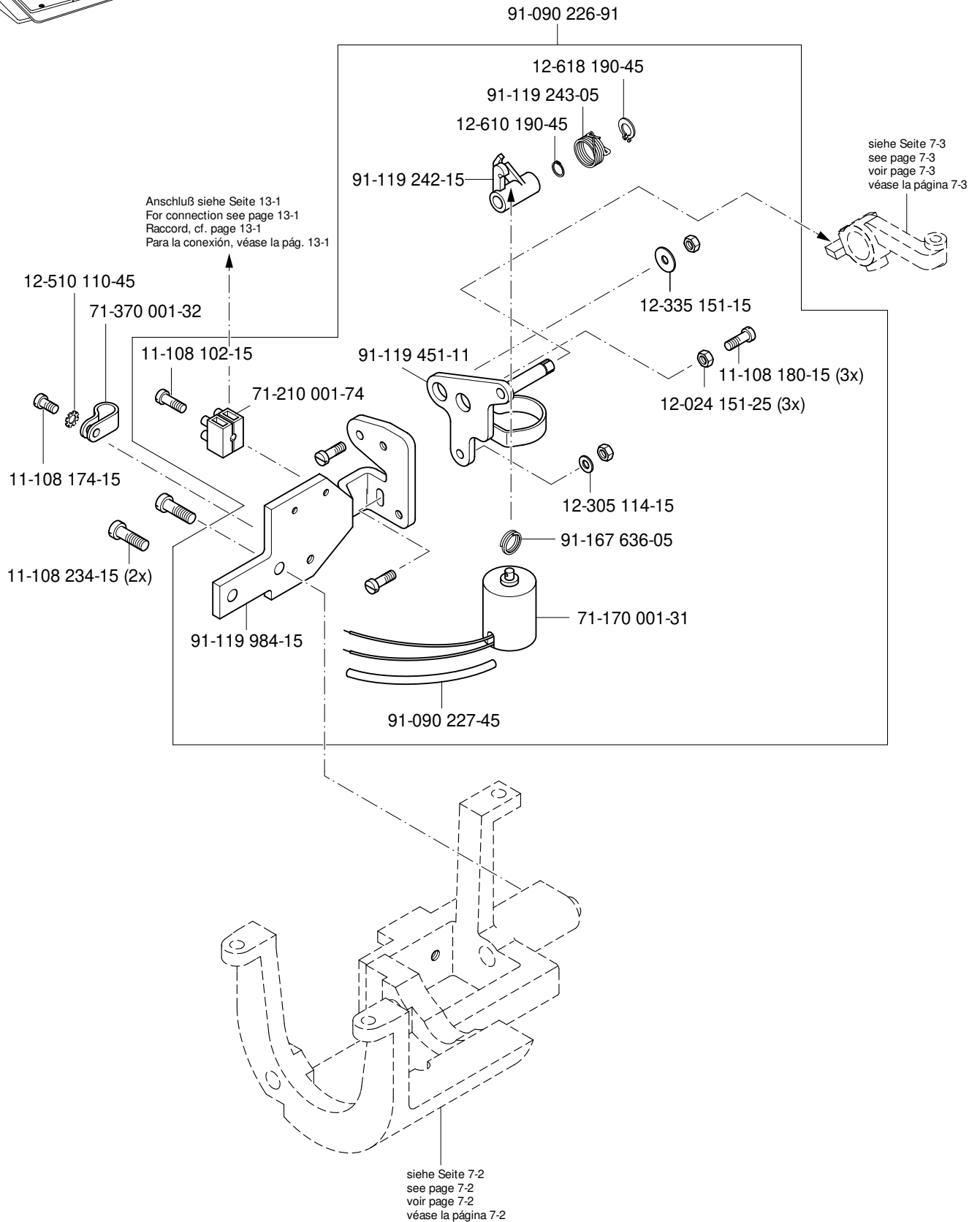

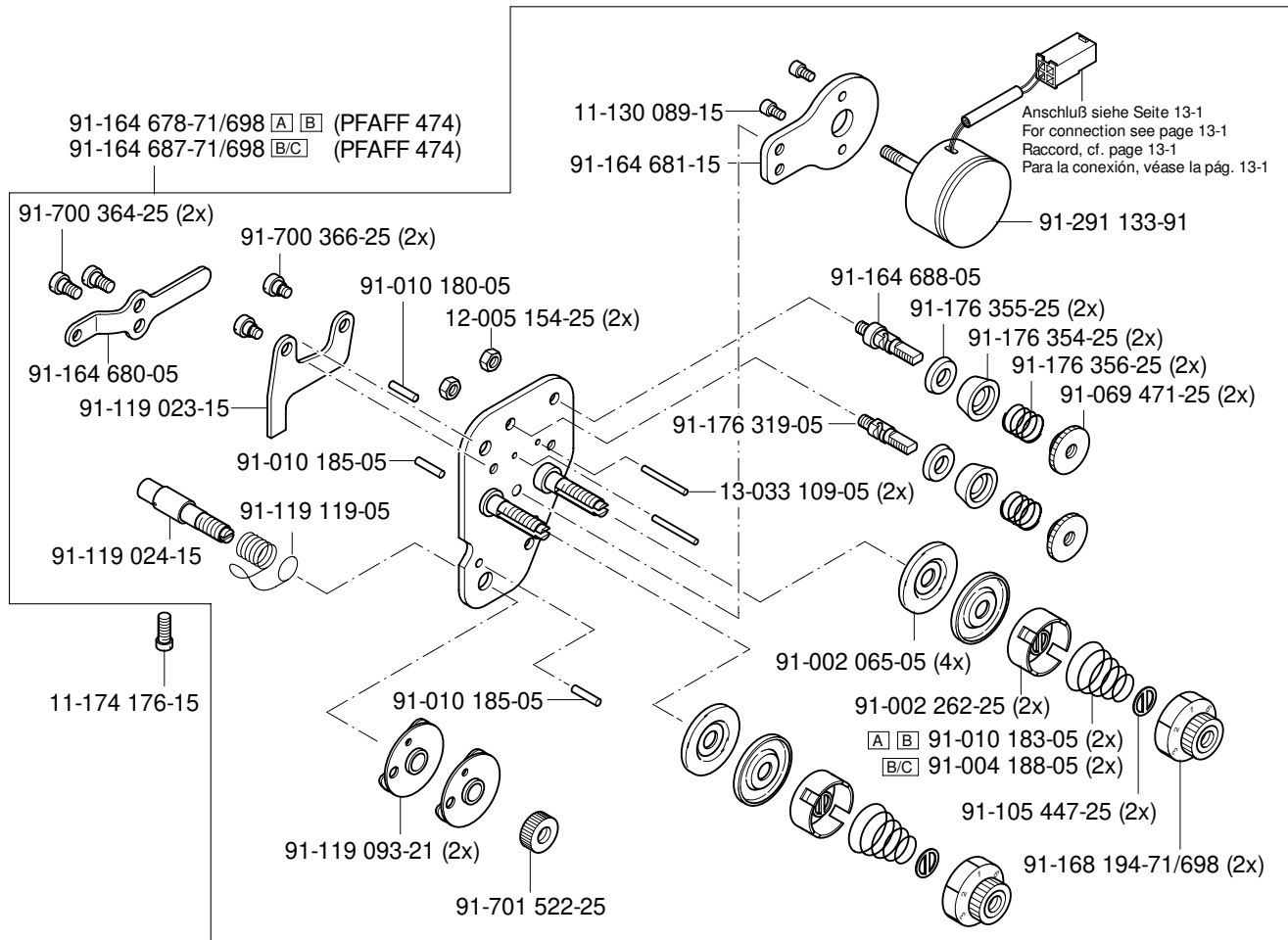
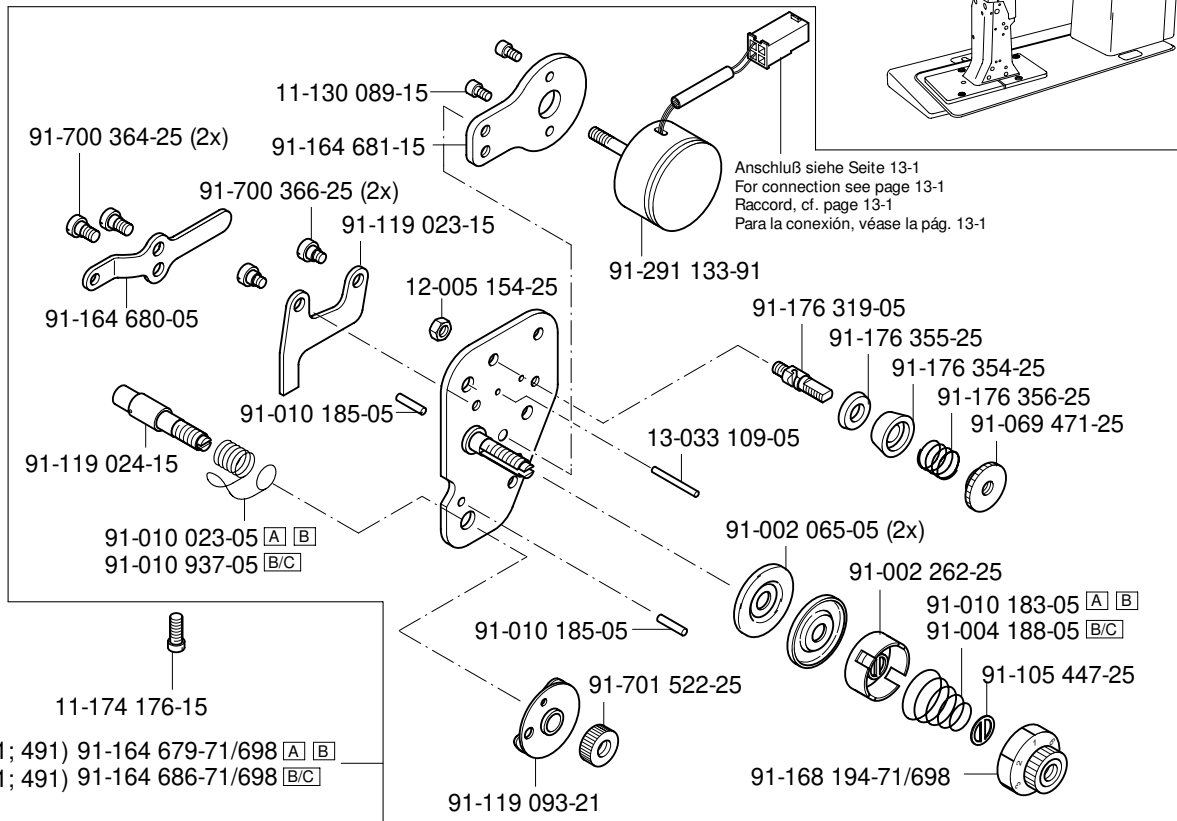
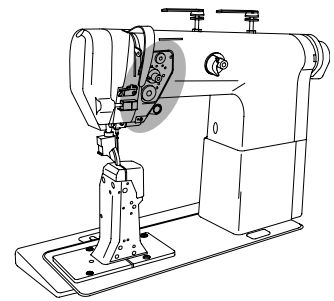

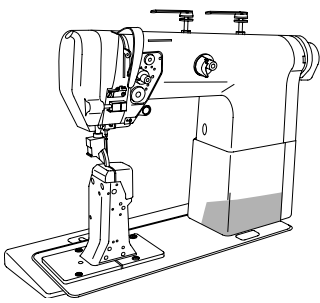

Presserfuß-Automatik (-910/15)
 Automatic presser foot lifter (-910/15)
 Relève-pied automatique (-910/15)
 Alzaprensatelas (-910/15)

PFAFF 471
 PFAFF 474
 PFAFF 491

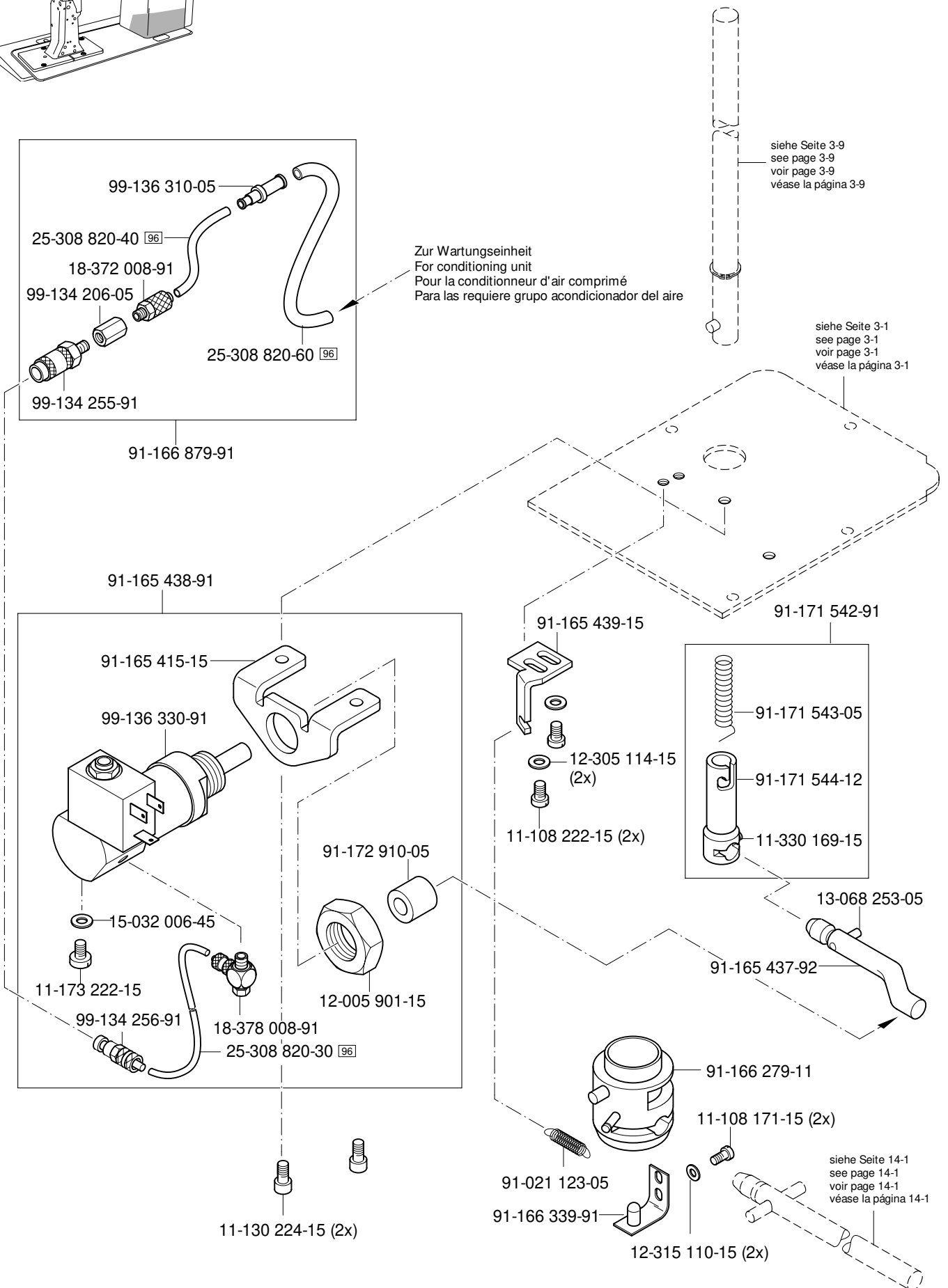

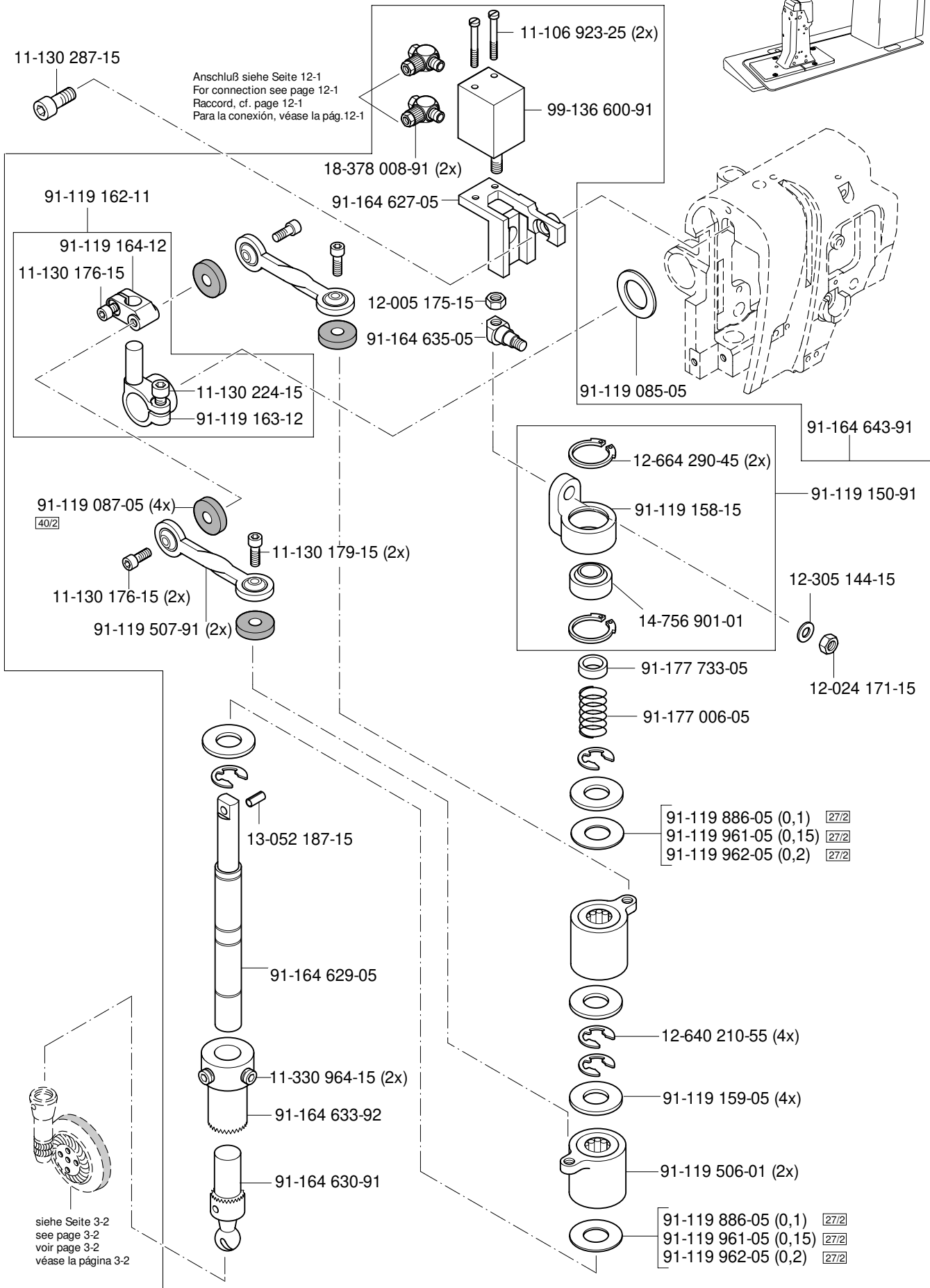
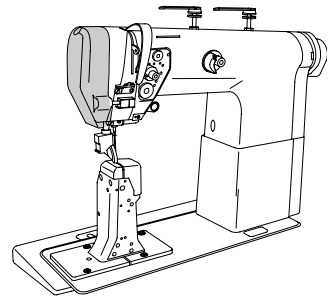

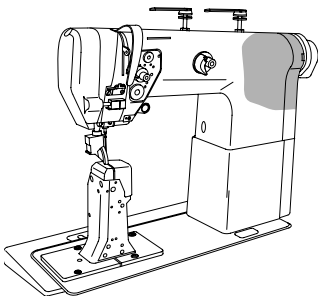

Verriegelungs-Einrichtung (-911/35)
 Backtacking mechanism (-911/35)
 Dispositif à points d'arrêt (-911/35)
 Rematador (-911/35)

PFAFF 471
 PFAFF 474
 PFAFF 491

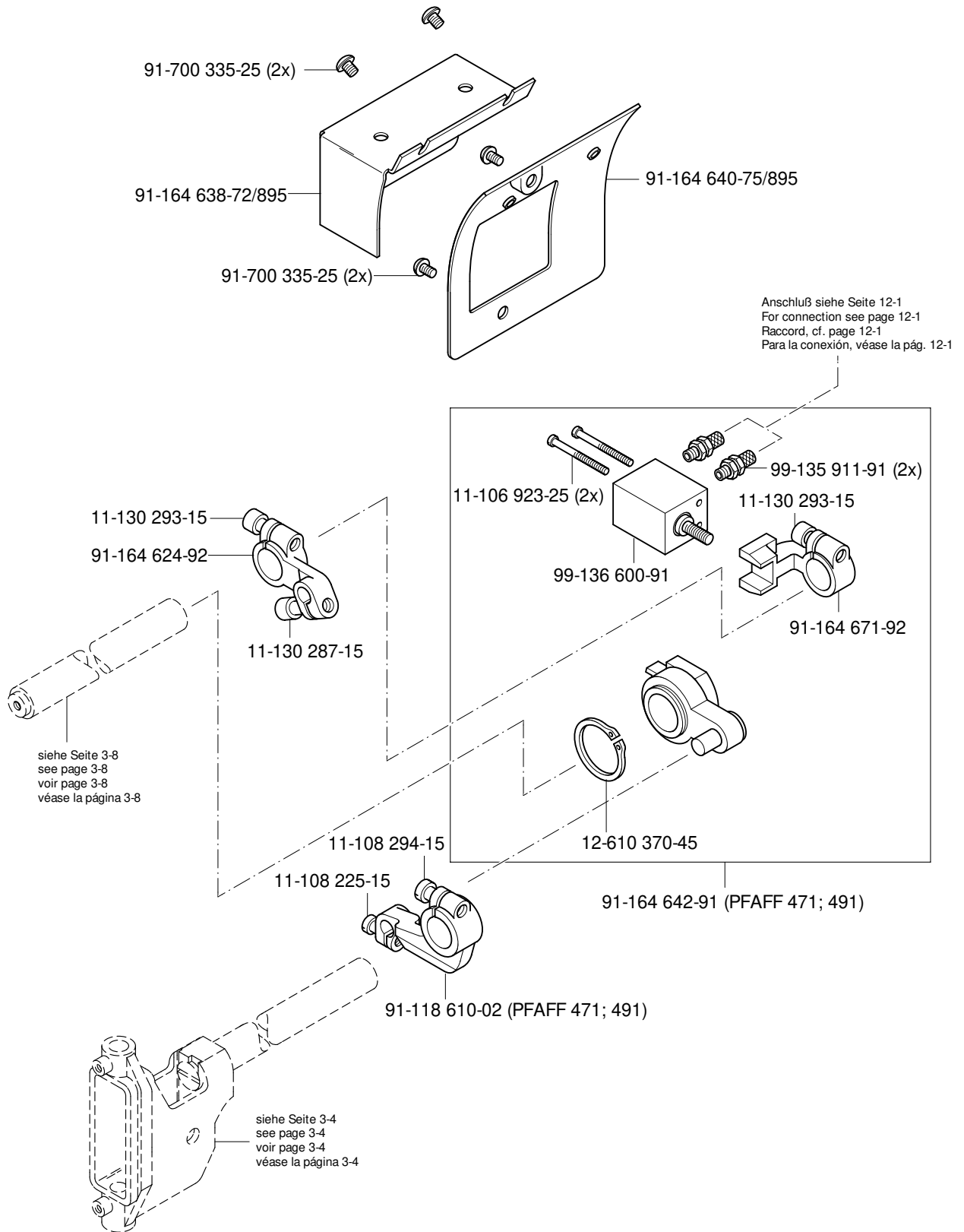

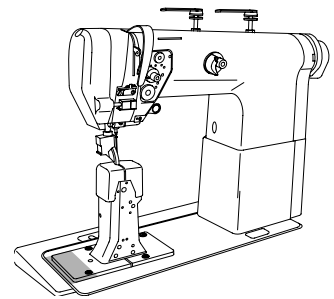

siehe Seite 4-2
 see page 4-2
 voir page 4-2
 véase la página 4-2

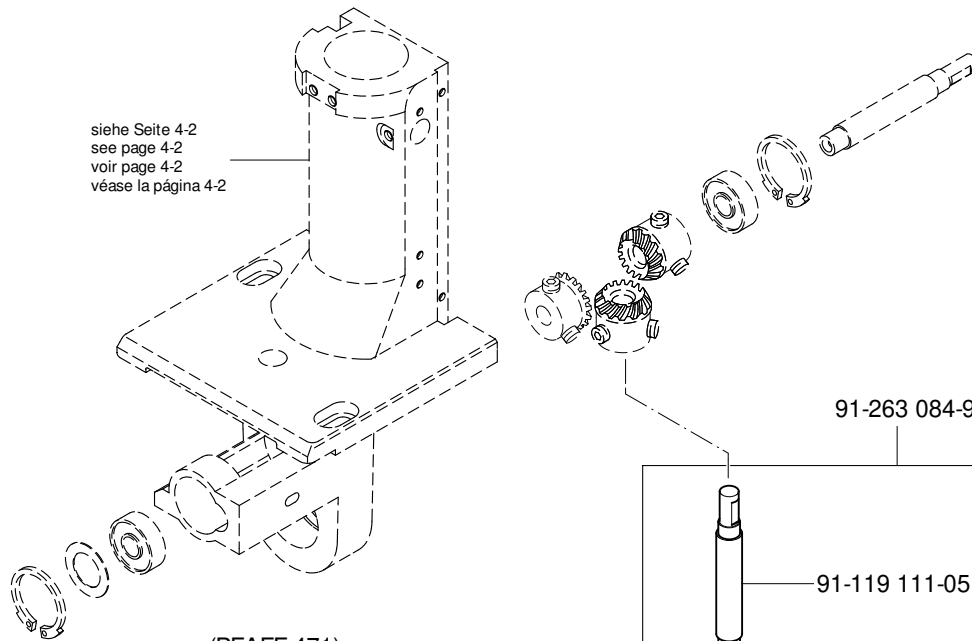

(PFAFF 471)

siehe Seite 3-11
 see page 3-11
 voir page 3-11
 véase la página 3-11

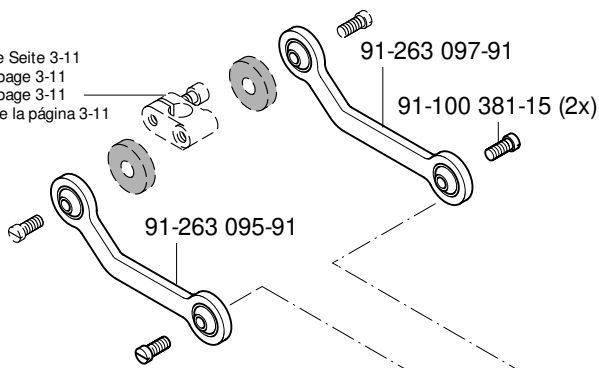

(PFAFF 474)

siehe Seite 3-11
 see page 3-11
 voir page 3-11
 véase la página 3-11

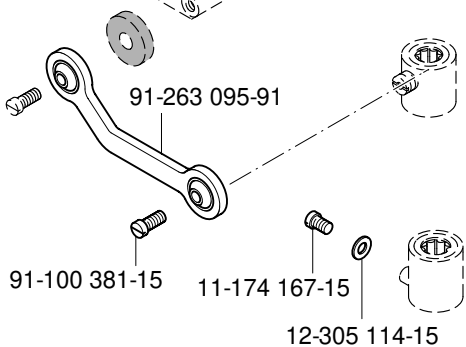

91-263 084-91

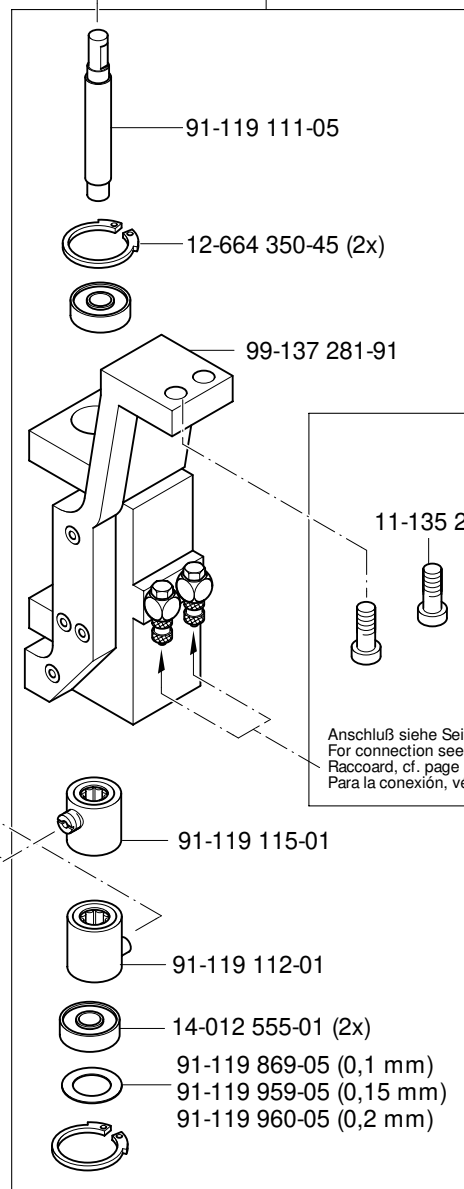

91-119 111-05

12-664 350-45 (2x)

99-137 281-91

11-135 292-15 (2x)

Anschluß siehe Seite 12-1
 For connection see page 12-1
 Raccord, cf. page 12-1
 Para la conexión, véase la pág. 12-1

91-119 115-01

91-119 112-01

14-012 555-01 (2x)

91-119 869-05 (0,1 mm)

91-119 959-05 (0,15 mm)

91-119 960-05 (0,2 mm)

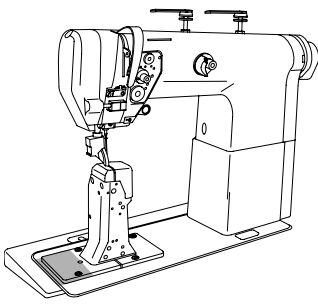

Verriegelungs-Einrichtung (-911/35)
 Backtacking mechanism (-911/35)
 Dispositif à points d'arrêt (-911/35)
 Rematador (-911/35)

PFAFF 491

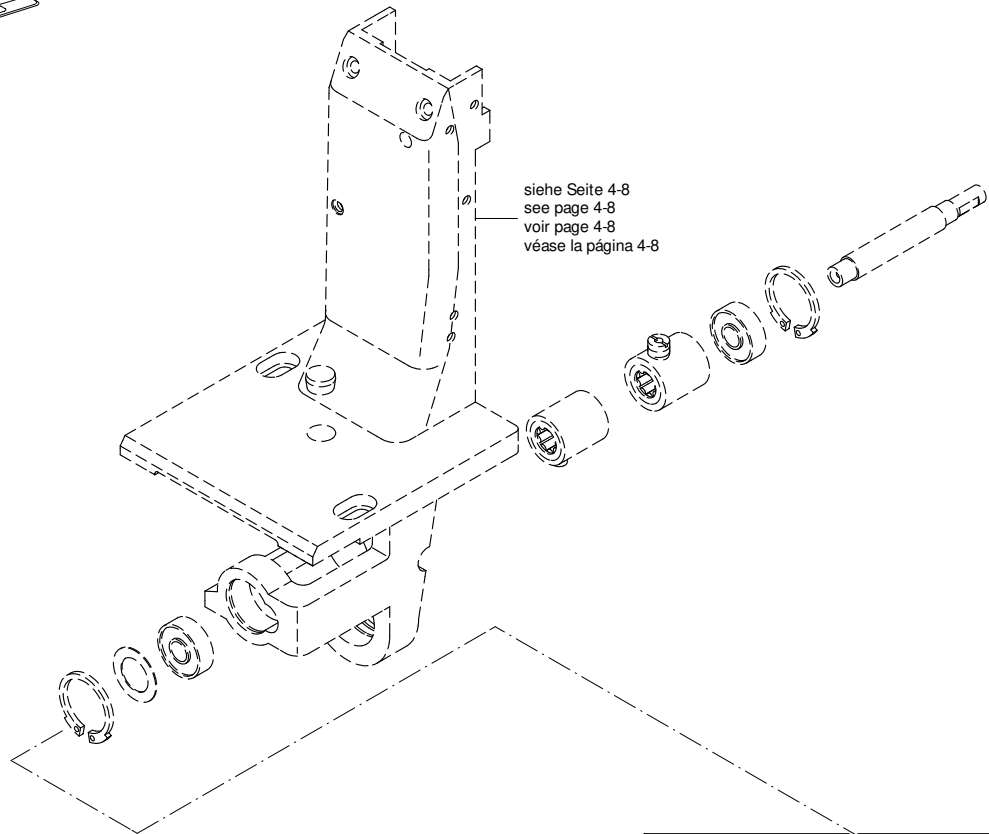

siehe Seite 4-8
 see page 4-8
 voir page 4-8
 véase la página 4-8

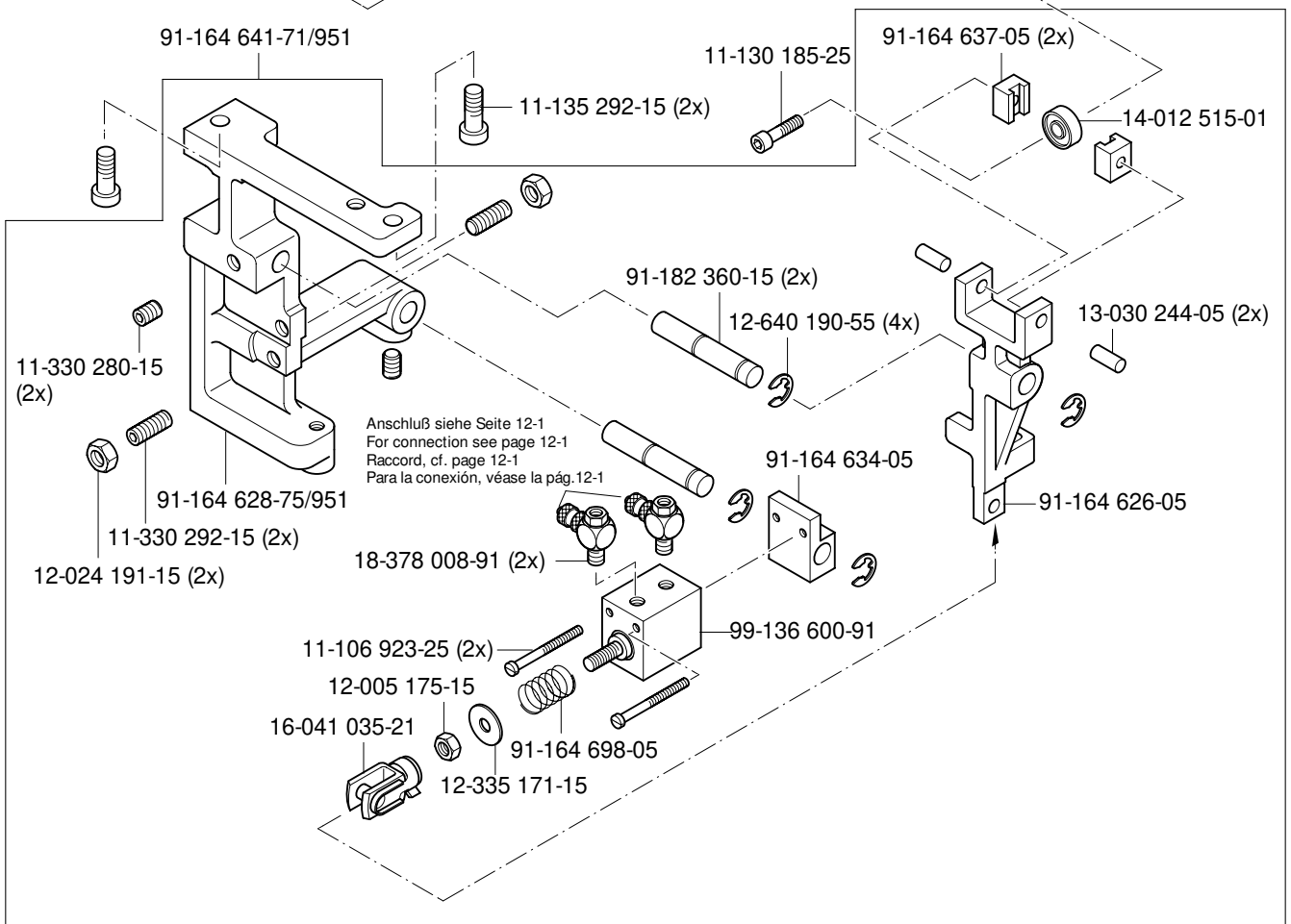

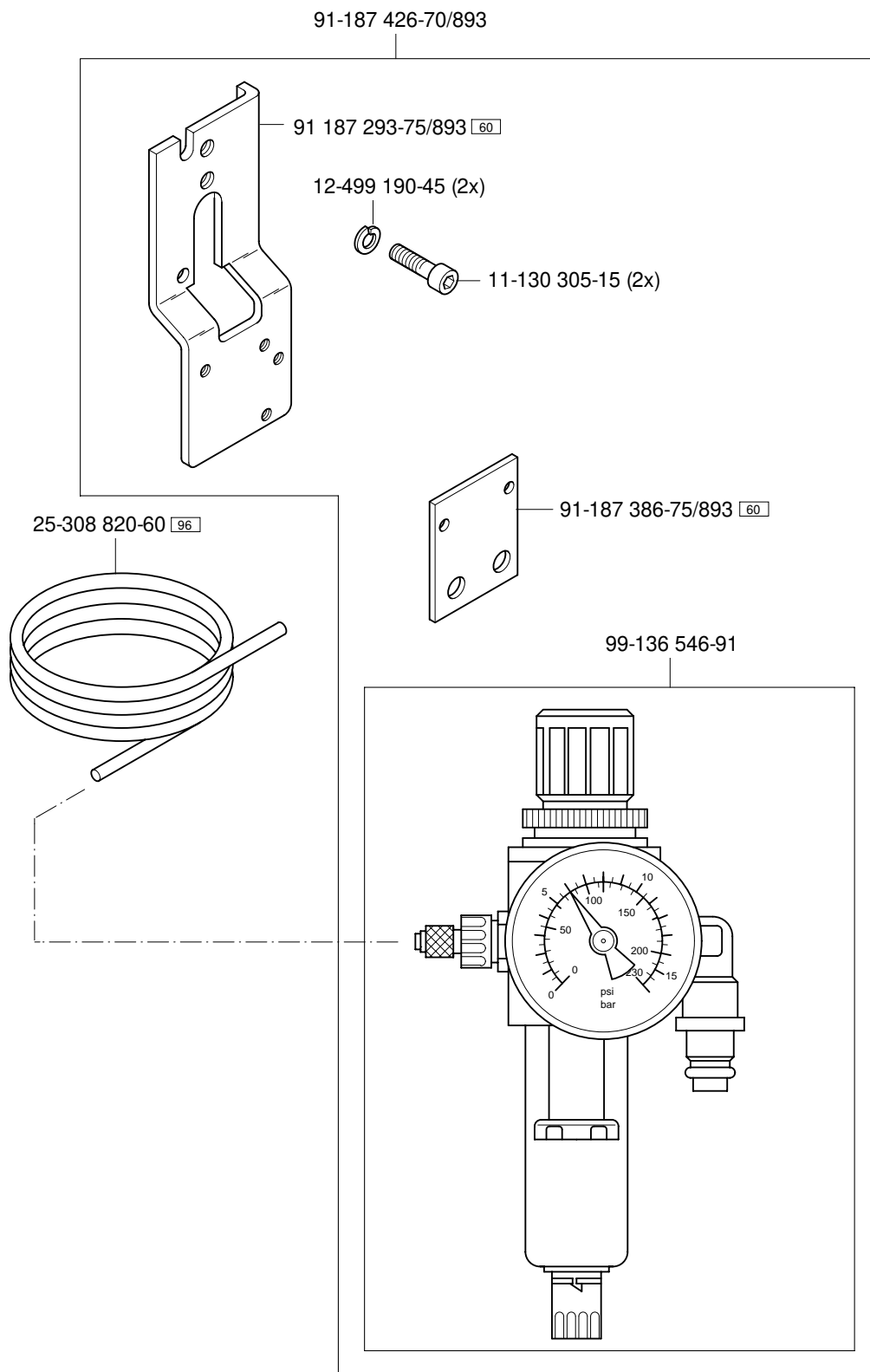

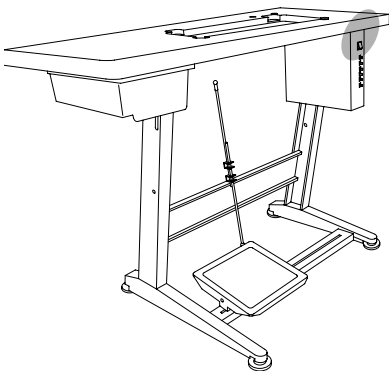

Pneumatische Ausrüstung
 Pneumatic equipment
 Equipement pneumatique
 Equipo neumático

PFAFF 471-911/35
 PFAFF 474-911/35
 PFAFF 491-911/35

Zur Wartungseinheit
 For conditioning unit
 Pour la conditionneur d'air comprimé
 Para las requiere grupo acondicionador del aire

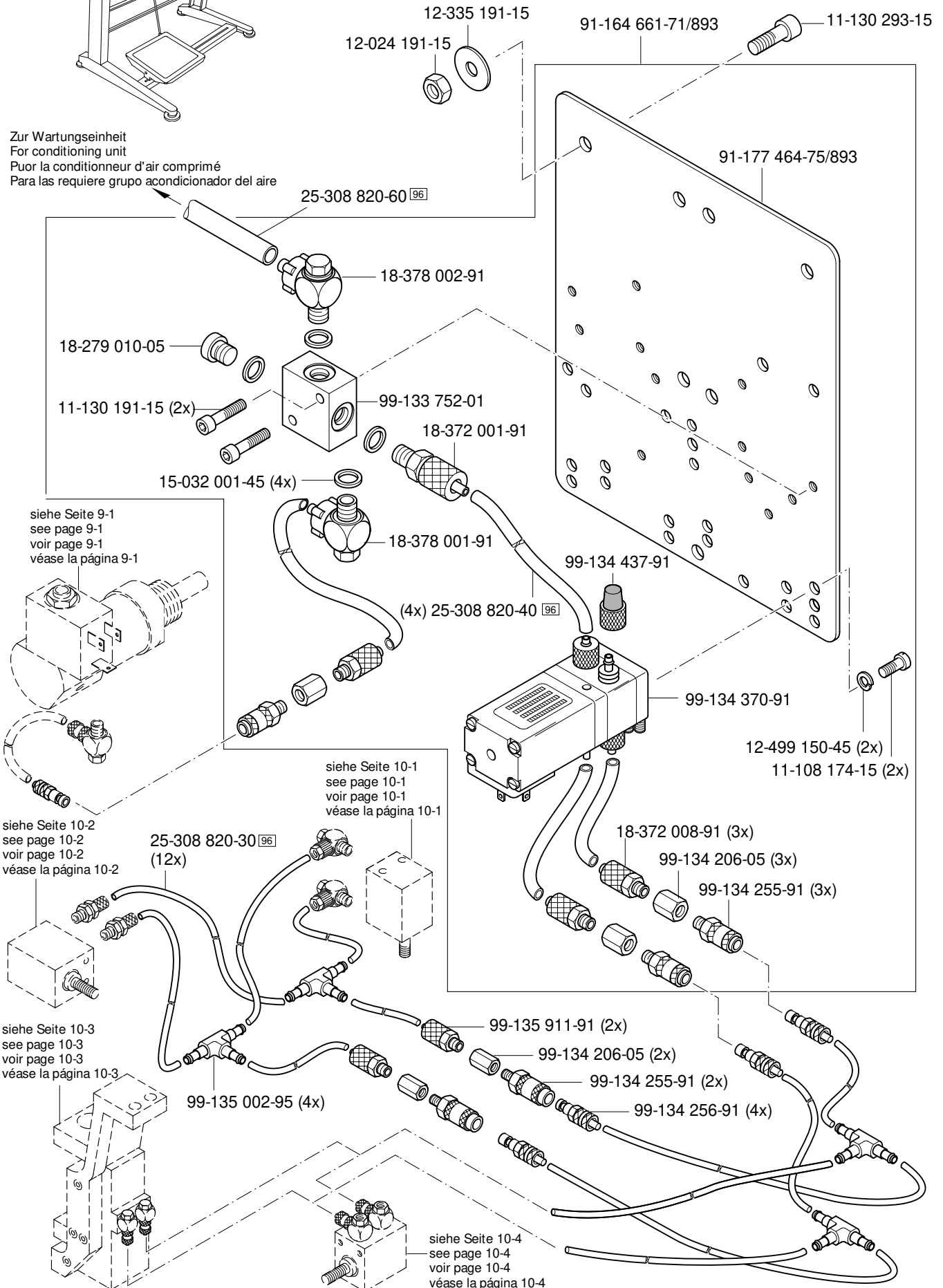

13.01

Kabelbaum zum Oberteil PFAFF 471-900/53
 Cable tree to sewing head PFAFF 474-900/53
 Faisceau de câbles vers la tête de machine
 Mazo de cables para el cabezal PFAFF 491-900/53

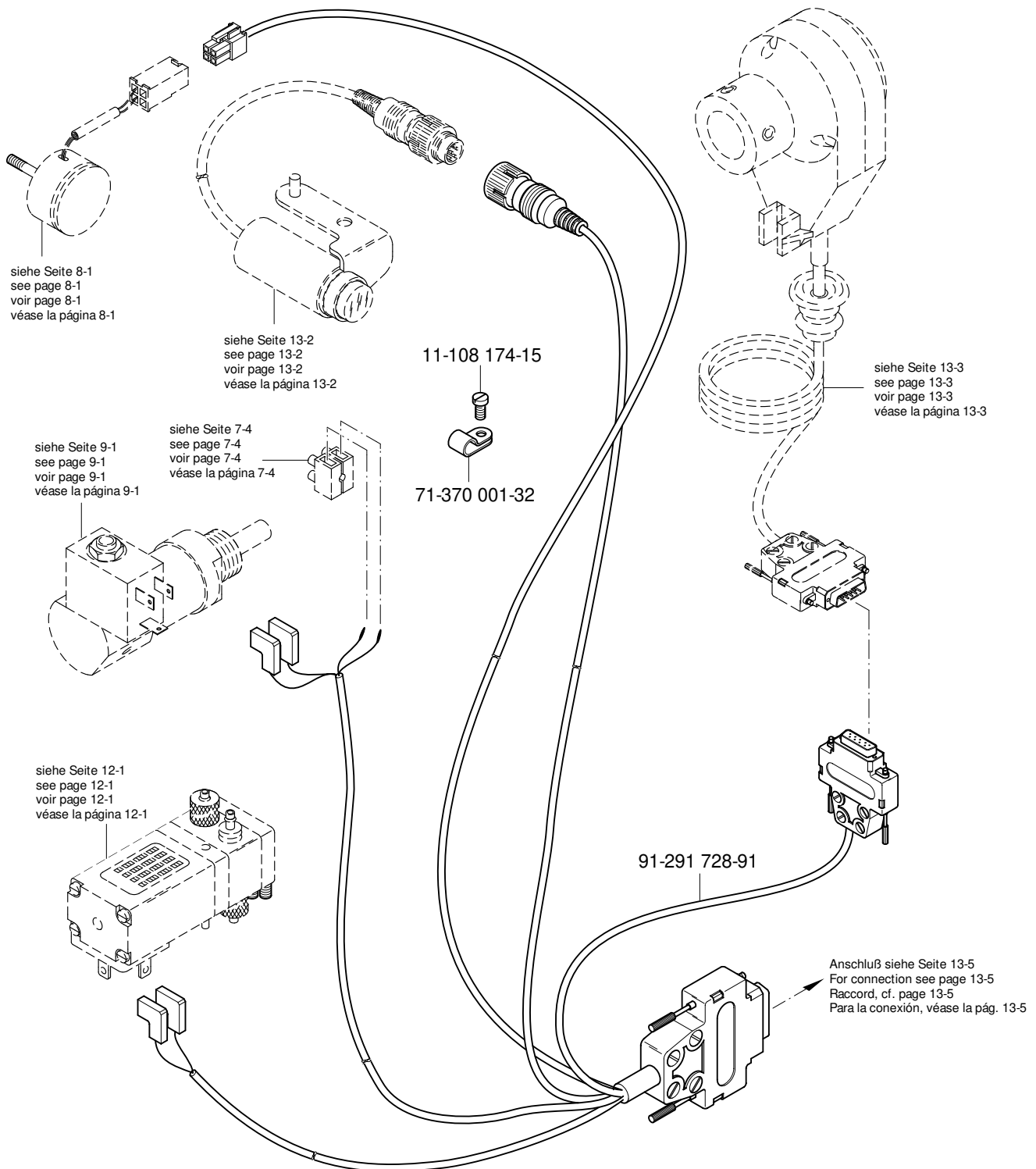
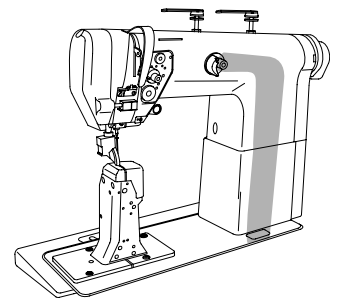

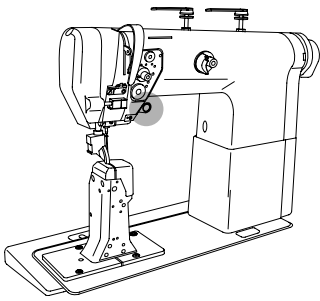

Tastschalter
 Push-button switch
 Interrupteur à bouton-poussoir
 Interruptor pulsador

PFAFF 471-911/35
 PFAFF 474-911/35
 PFAFF 491-911/35

13.02

Anschluß siehe Seite 13-1
 For connection see page 13-1
 Raccordo, cf. page 13-1
 Para la conexión, véase la pág. 13-1

91-088 273-91 (-726/05)

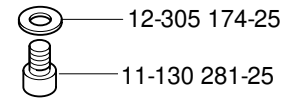
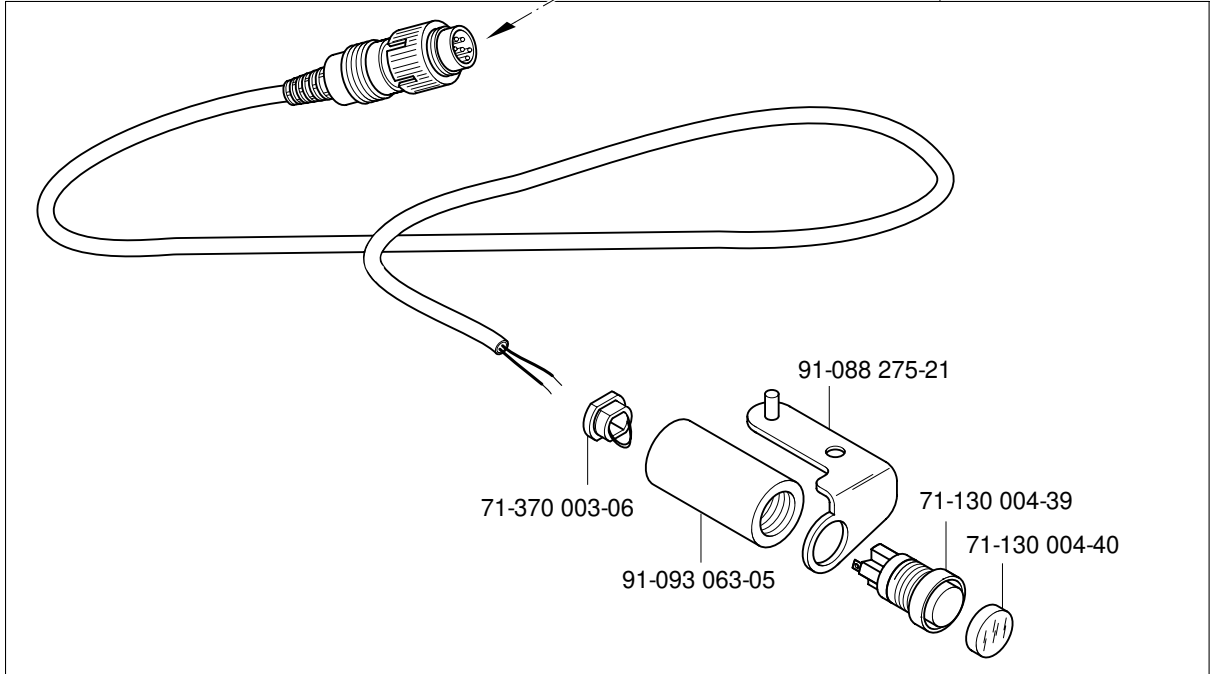

91-089 095-91

Anschluß siehe Seite 13-1
 For connection see page 13-1
 Raccordo, cf. page 13-1
 Para la conexión, véase la pág. 13-1

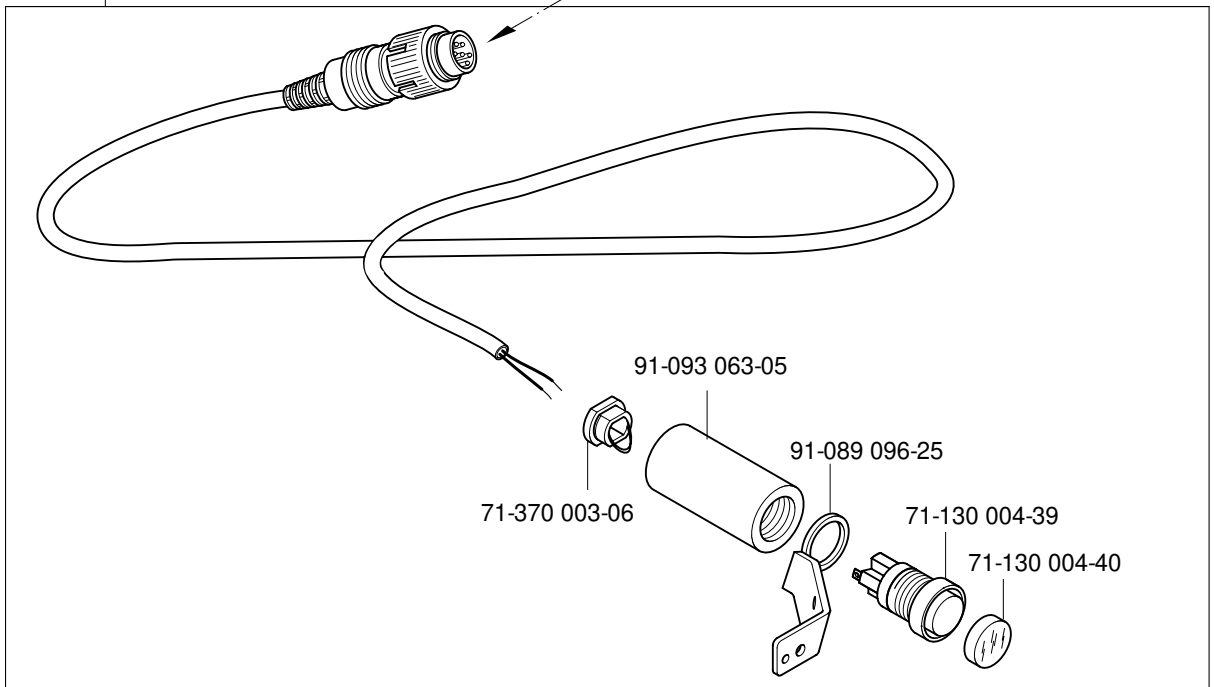

11-108 186-25

13.03

Einbaumotor, Positionsgeber
 Built-in motor, Synchronizer PFAFF 471-900/53
 Moteur incorporé, Synchronisateur PFAFF 474-900/53
 Motor incorporado, Sincronizador PFAFF 491-900/53

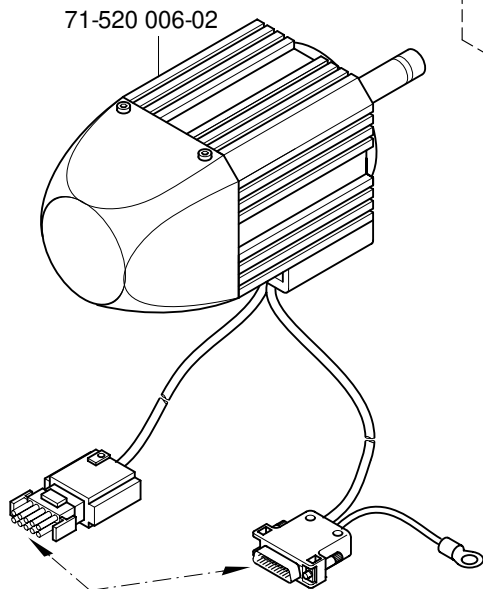
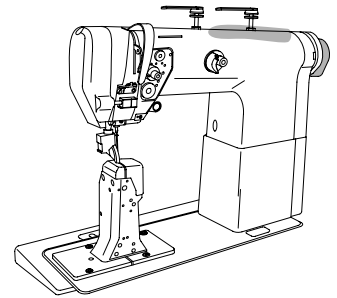

71-520 006-02
 Anschluß siehe Seite 13-5
 For connection see page 13-5
 Raccord, cf. page 13-5
 Para la conexión, véase la pág. 13-5

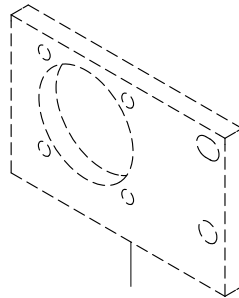

siehe Seite 7-1
 see page 7-1
 voir page 7-1
 véase la página 7-1

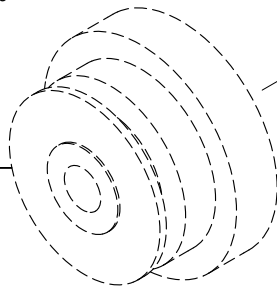

siehe Seite 3-7
 see page 3-7
 voir page 3-7
 véase la página 3-7

71-590 007-32 (PO 3)

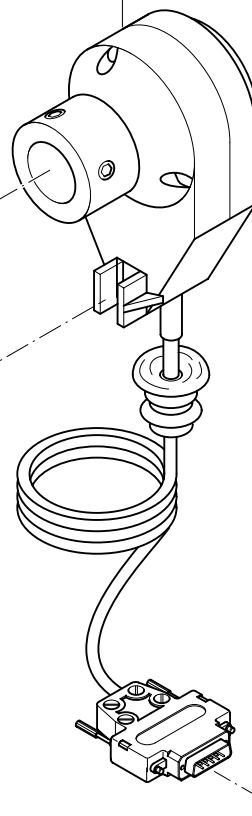

Anschluß siehe Seite 13-1
 For connection see page 13-1
 Raccord, cf. page 13-1
 Para la conexión, véase la pág. 13-1

91-141 688-90

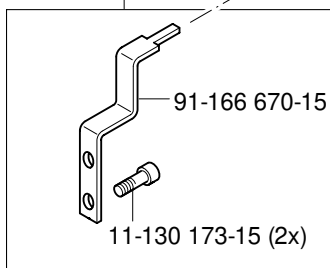

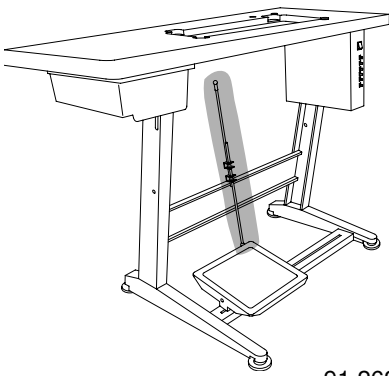

Sollwertgeber
Set-point generator
Codeur
Emisor del valor teórico

PFAFF 471
PFAFF 474
PFAFF 491

13.04

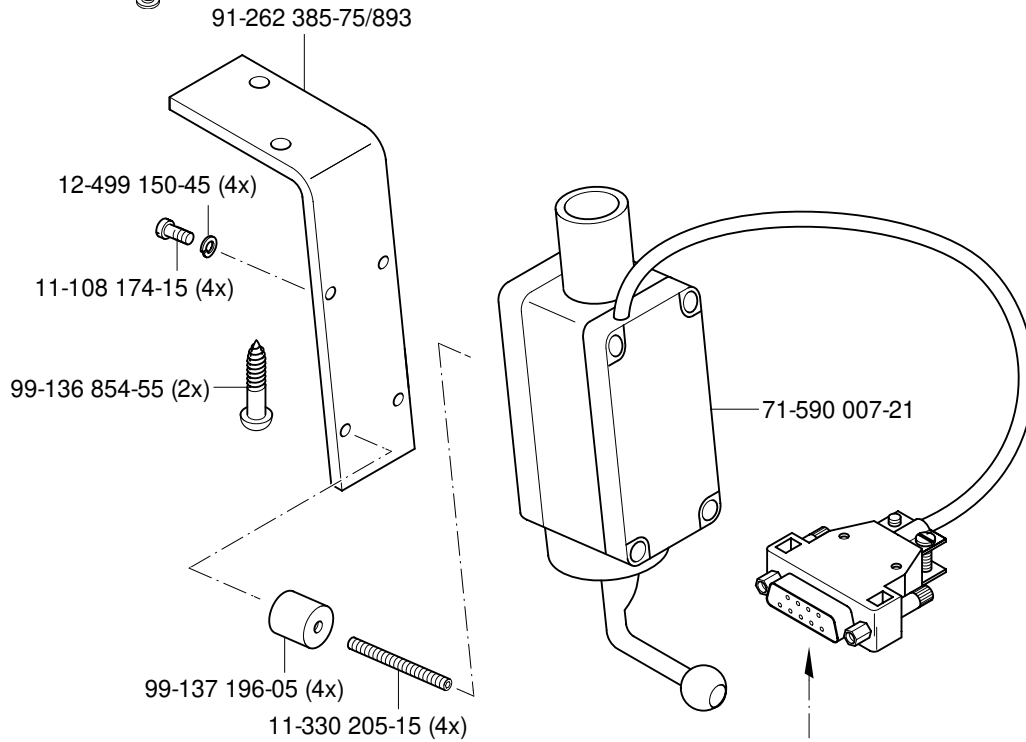

Anschluß siehe Seite 13-5
For connection see page 13-5
Raccordo, cf. page 13-5
Para la conexión, véase la pág. 13-5

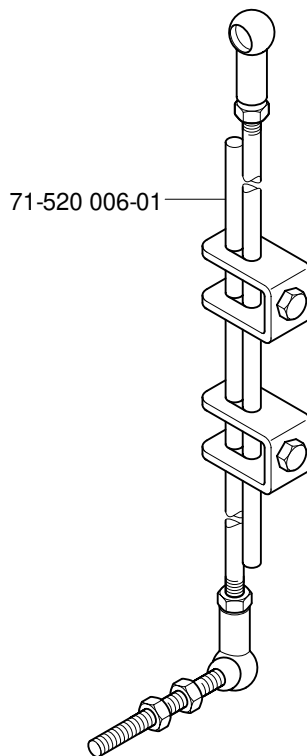

Zur Tretplatte
For the pedal
Pour la pédale
Para el pedal

13.05

Steuerkasten
Control box
Boîtier de contrôle
Caja de mandos

PFAFF 471
PFAFF 474
PFAFF 491

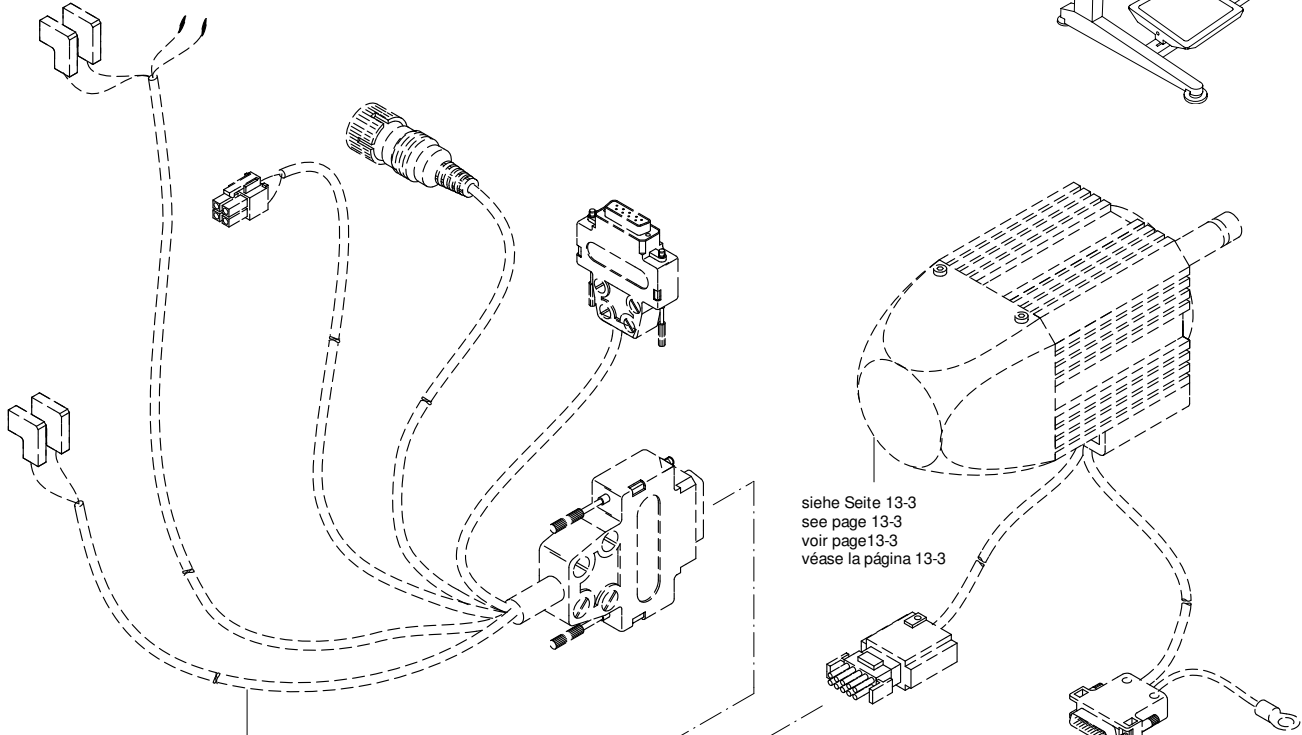
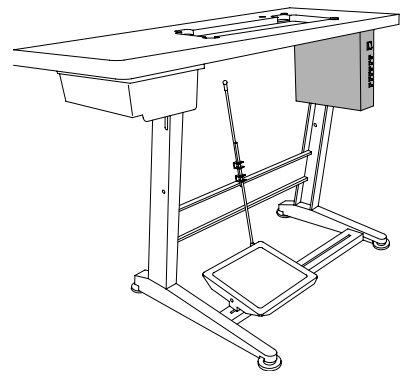

siehe Seite 13-1
see page 13-1
voir page 13-1
véase la página 13-1

siehe Seite 13-3
see page 13-3
voir page 13-3
véase la página 13-3

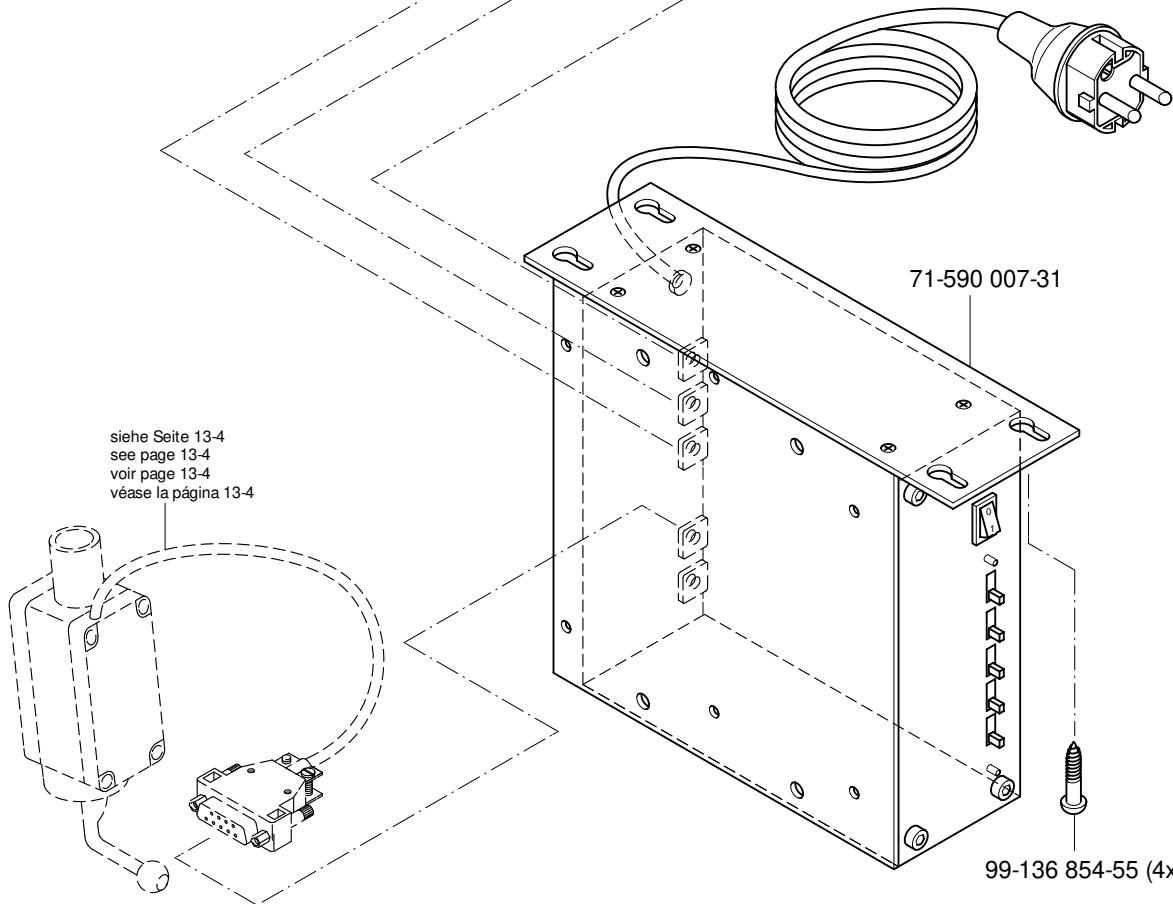

siehe Seite 13-4
see page 13-4
voir page 13-4
véase la página 13-4

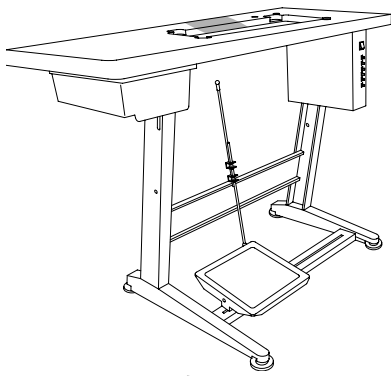

Steuergerät
Control device
Boîte de commande
Caja de mandos

PFAFF 471-725/04
PFAFF 474-725/04
PFAFF 491-725/04

13.06

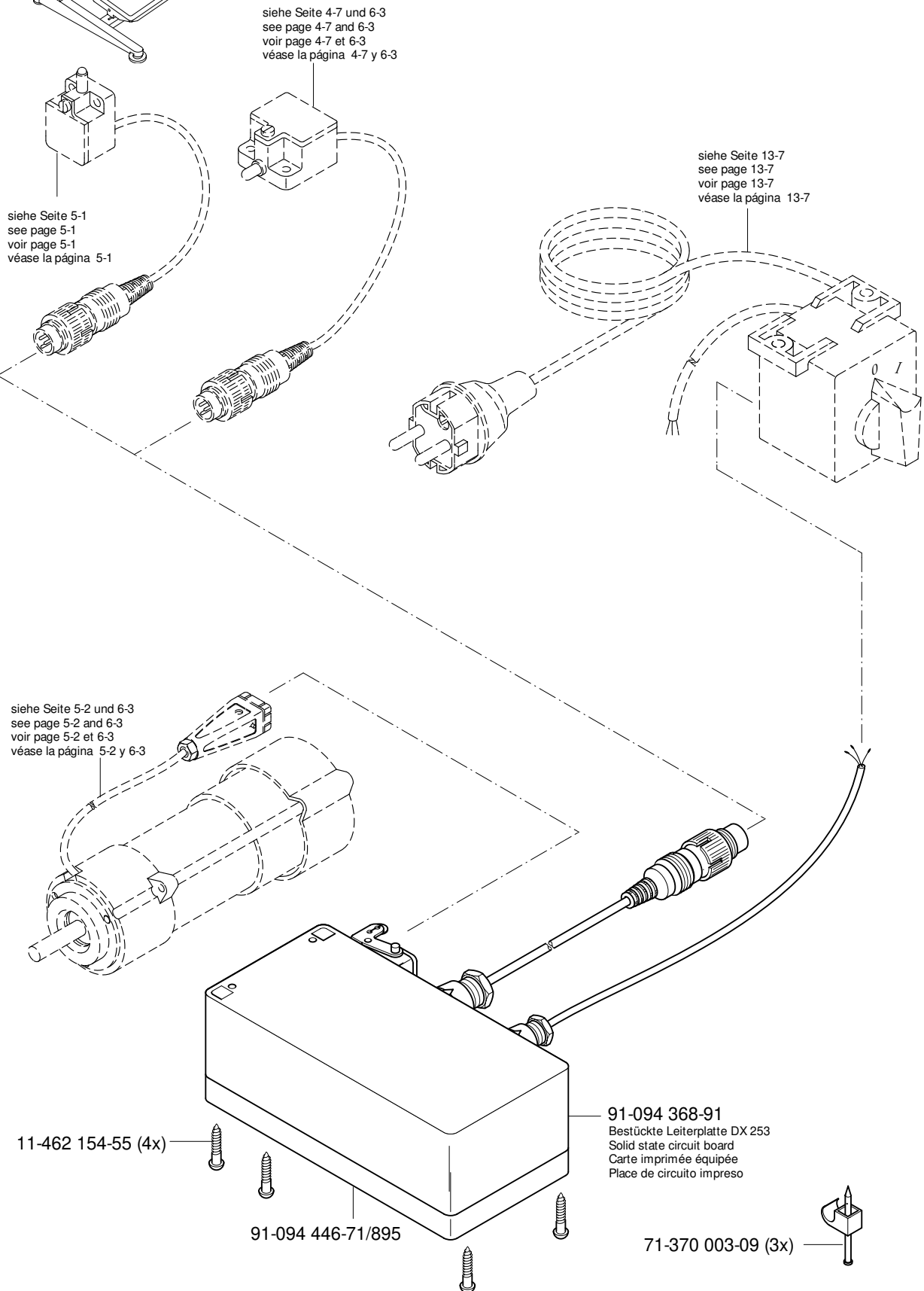

13.07

Motordrehschalter
Motor turn switch PFAFF 471-725/04
Interrupteur rotatif PFAFF 474-725/04
Interruptor giratorio PFAFF 491-725/04; -726/05

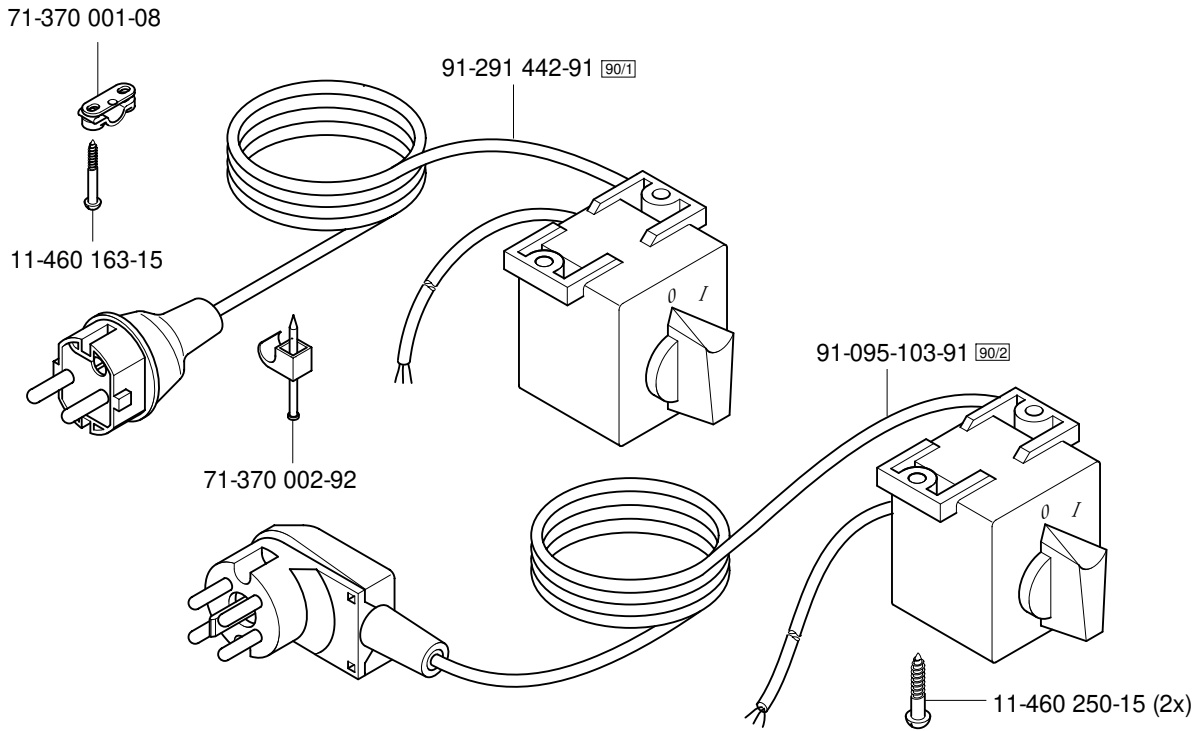
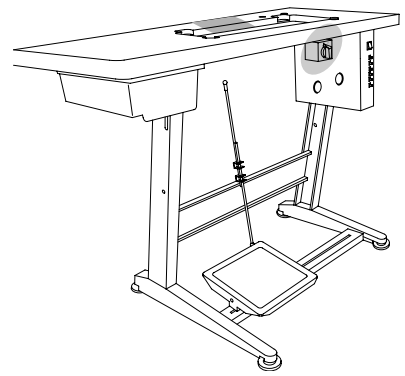

Keilriemen
 V-belt
 Courroie trapézoïdale
 Correa trapezoidal

PFAFF 471
 PFAFF 474
 PFAFF 491

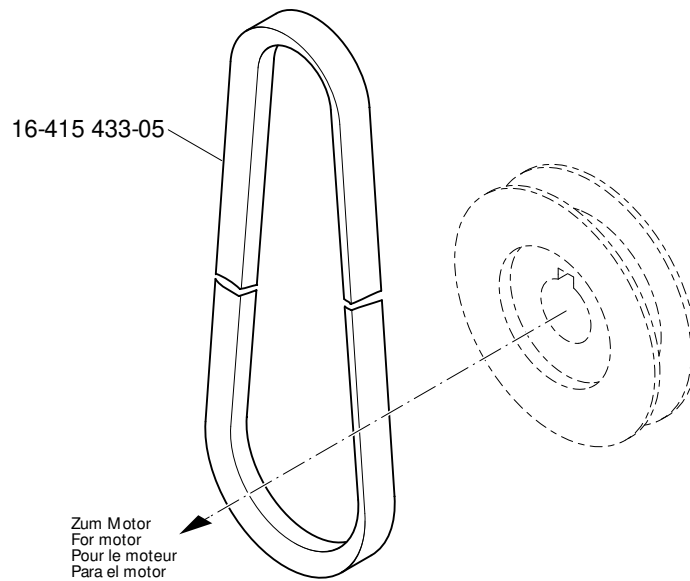

Knielüfterteile
 Knee lifter parts
 Pièces du releveur de genouillère
 Piezas del alzaprensateles por rodillera

PFAFF 471
 PFAFF 474
 PFAFF 491

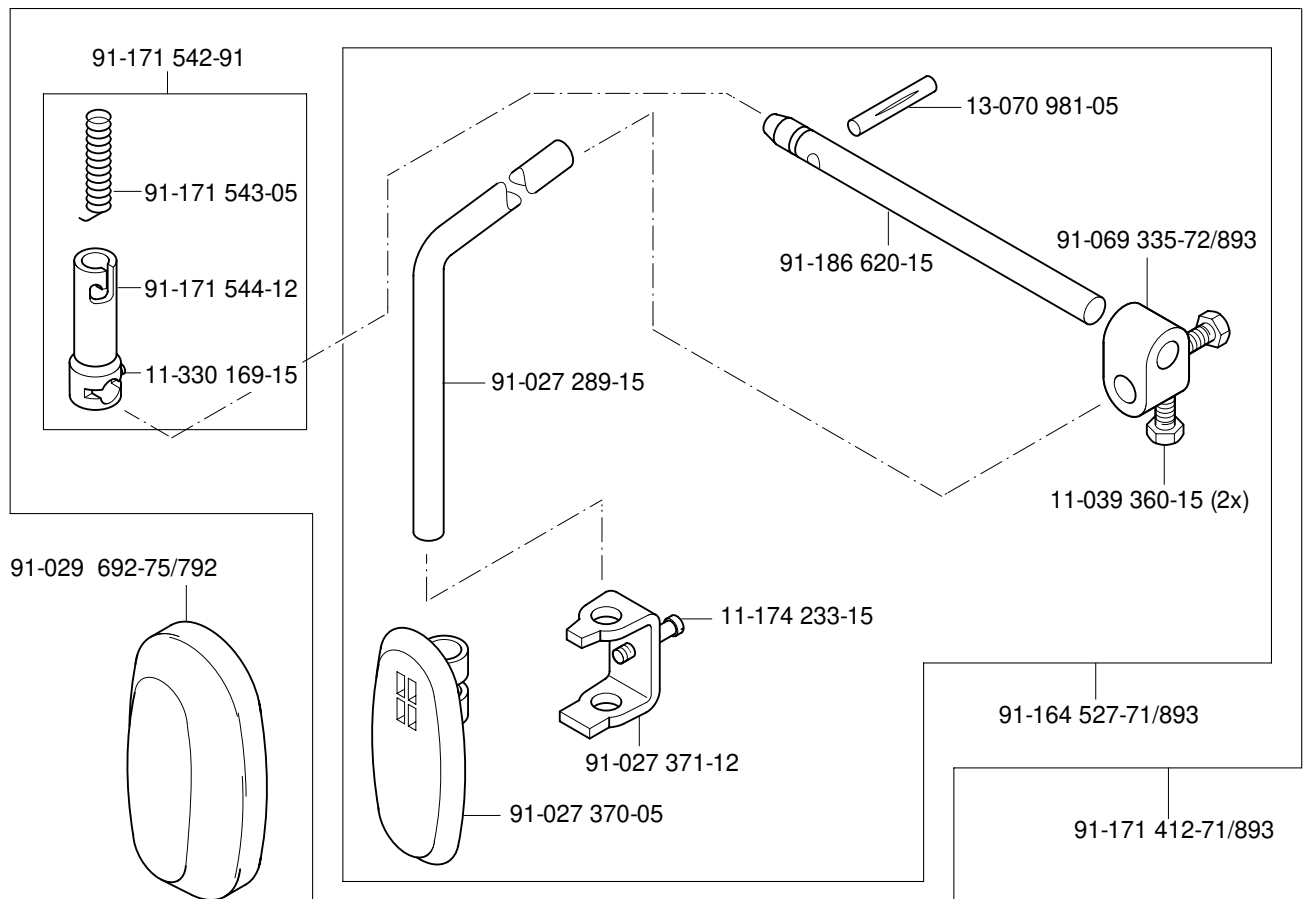

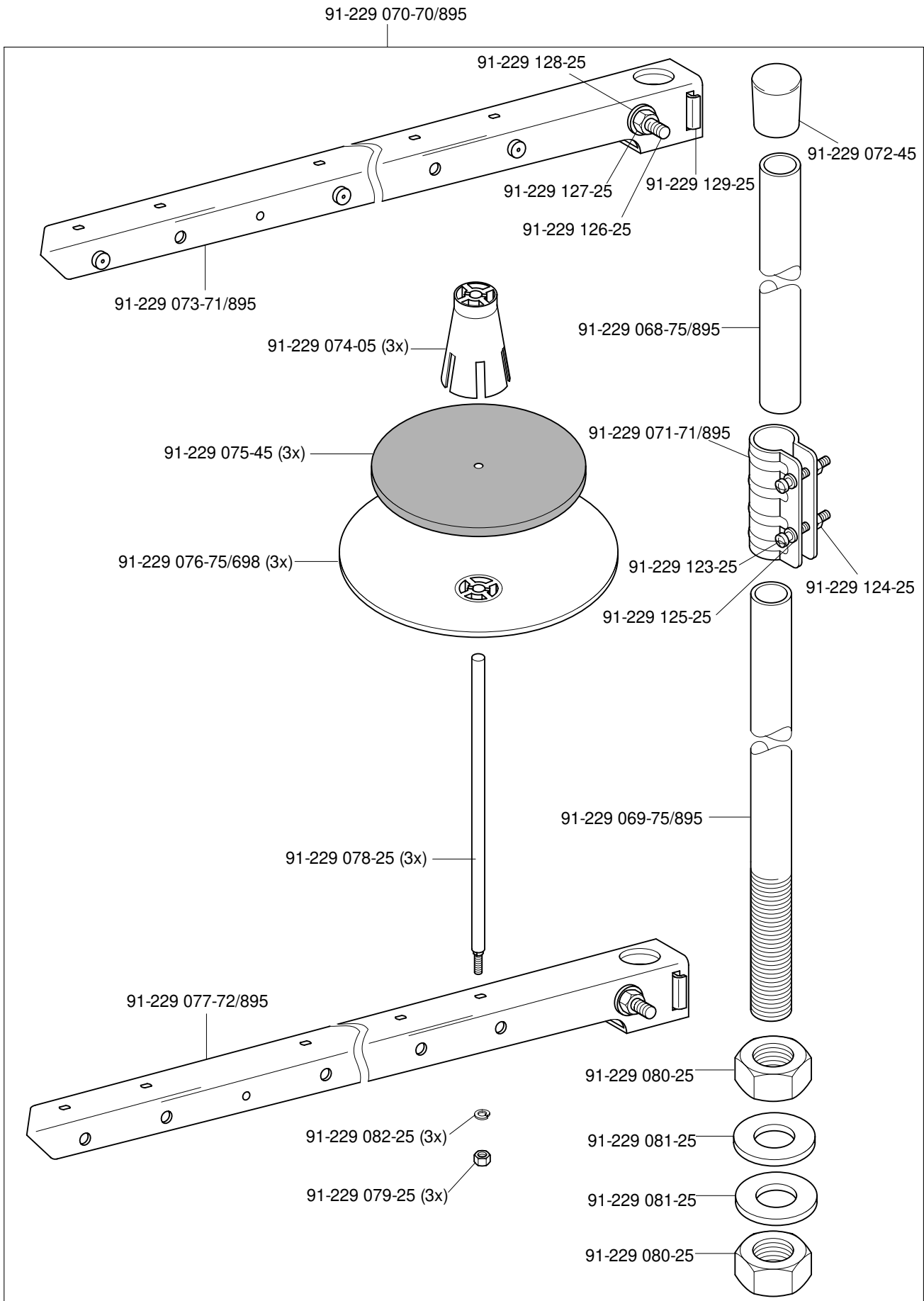

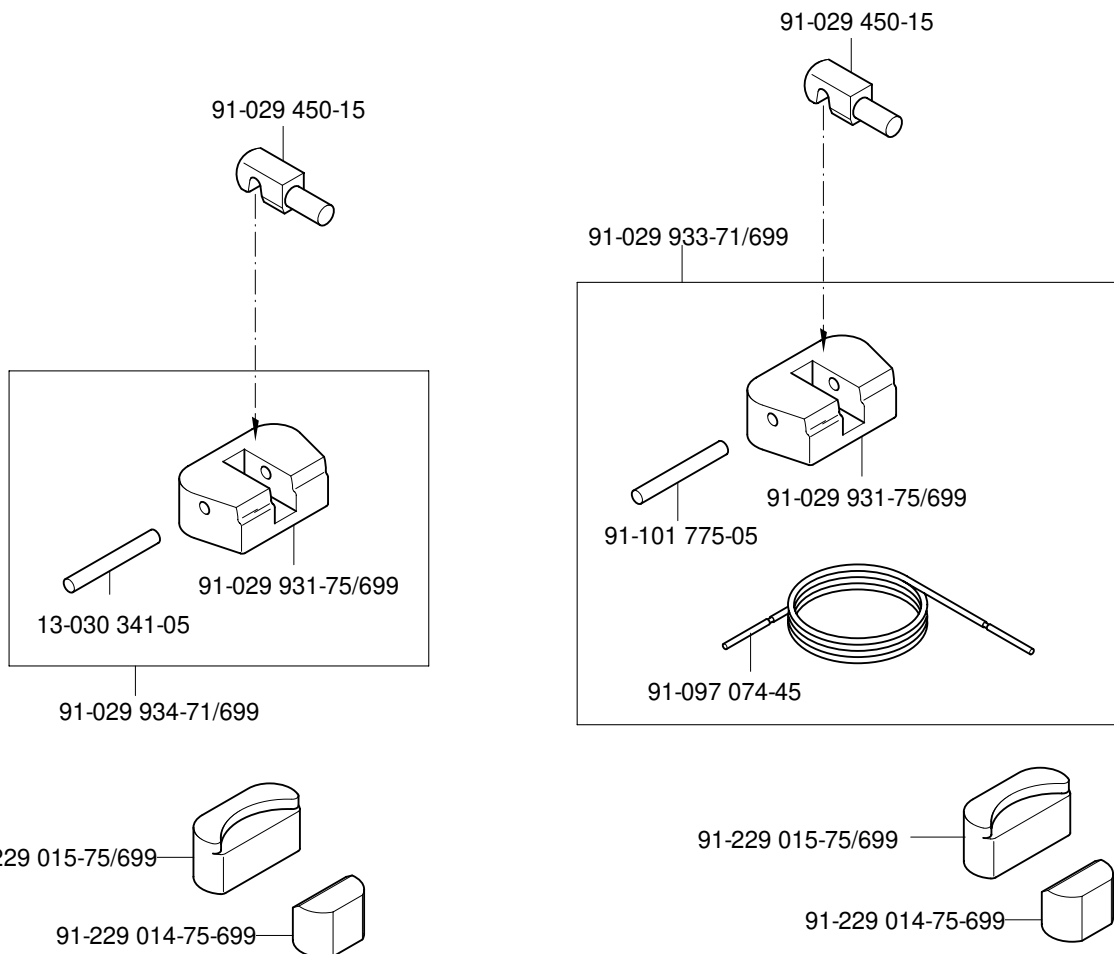
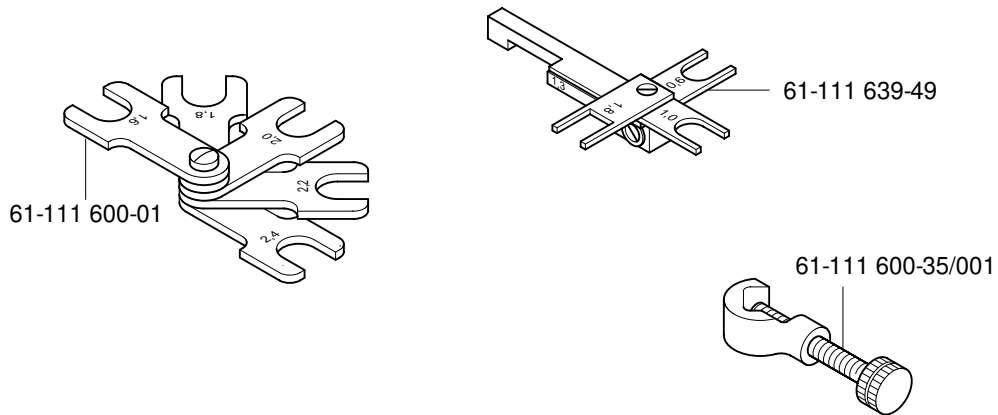

Öl Oil Huile Aceite	Mittelpunkts-Viskosität bei: Mean viscosity at: Viscosité moyenne à: Viscosidad media a:		Dichte bei: Density of: Densité à: Densidad a:		Bestellnummer für Behälter mit: Part number for can with: Numéro de commande pour récipients avec: Número de pedido para recipientes con:		
	°C	mm ² /s	°C	g/cm ³ (g/ml)	1 Liter 1 Litre 1 Litro	5 Liter 5 Litre 5 Litros	10 Liter 10 Litre 10 Litros
28-011 20 1-44	40	22,0	15	0,865	91-129 917-91	91-129 919-91	91-129 920-91
28-011 202-17 (Fadenschmiermittel) (Thread lubricant) (Agents de lubrification de fil) (Lubricantes del hilo)	40	5,8	21	0,810	91-129 941-91		

Fett Grease Graisse Grasa	Penetration Penetration Pénétration Penetración	Tropfpunkt Drip-point Point de suintement Punto de goteo	Bestellnummer für Behälter mit: Part number for can with: Numéro de commande pour récipients avec: Número de pedido para recipientes con:		
			mm/10	°C	0,25 kg
28-011 202-05					28-011 202-05
28-011 202-43	375-405	150			28-011 202-43
28-011 202-47	220-250	185			28-011 202-47

Reinigungsmittel Cleansing agent Agents de nettoyage Limpiadores	Bestellnummer für Behälter mit: Part number for can with: Numéro de commande pour récipients avec: Número de pedido para recipientes con:		
	240 ml		
Isopropyl-Alkohol	95-665 735-91		

No.	Seite Page Pages Página	No.	Seite Page Pages Página	No.	Seite Page Pages Página	No.	Seite Page Pages Página
08-800 019-04	5 - 3	11-130 167-15	4 - 7, 5 - 3	11-174 173-15	3 - 4	11-330 169-15	7 - 2, 9 - 1, 14 - 1
11-039 225-15	3 - 4	11-130 173-15	3 - 3, 6 - 3, 13 - 3	11-174 176-15	3 - 5, 3 - 6, 4 - 7, 8 - 1	11-330 175-15	3 - 13, 5 - 3
11-039 360-15	14 - 1	11-130 176-15	3 - 2, 3 - 11, 10 - 1	11-174 179-15	4 - 2, 4 - 4, 4 - 6	11-330 205-15	13 - 4
11-106 923-25	10 - 1, 10 - 2, 10 - 4	11-130 179-15	3 - 2, 5 - 2, 10 - 1	11-174 224-15	4 - 7, 6 - 1	11-330 217-15	4 - 2, 4 - 4, 4 - 6, 4 - 7
11-106 947-15	6 - 1	11-130 185-15	6 - 3	11-174 233-15	14 - 1	11-330 220-15	3 - 4
11-108 084-15	5 - 3	11-130 185-25	10 - 4	11-178 172-15	3 - 2, 3 - 3	11-330 226-15	5 - 1
11-108 090-15	3 - 3, 4 - 1, 4 - 3, 4 - 5	11-130 191-15	12 - 1	11-178 175-15	4 - 2	11-330 277-15	3 - 12, 7 - 1
11-108 093-15	4 - 1, 4 - 3, 4 - 5	11-130 224-15	3 - 1, 3 - 2, 3 - 7, 3 - 11, 5 - 3, 6 - 2, 6 - 3, 7 - 3, 9 - 1, 10 - 1	11-180 169-25	3 - 5	11-330 280-15	3 - 7, 3 - 13, 7 - 1, 10 - 4
11-108 096-15	4 - 7		4 - 8	11-182 451-05	4 - 8	11-330 292-15	10 - 4
11-108 102-15	7 - 4	11-130 224-25		11-210 035-25	4 - 8	11-330 952-15	3 - 3, 3 - 10, 6 - 3
11-108 171-15	3 - 3, 3 - 5, 4 - 7, 5 - 1, 9 - 1	11-130 227-15	3 - 8, 3 - 9	11-210 038-15	4 - 8, 4 - 9	11-330 955-15	5 - 3
11-108 174-15	3 - 13, 4 - 10, 5 - 3, 6 - 3, 7 - 2, 7 - 4, 12 - 1, 13 - 1, 13 - 4	11-130 233-15	3 - 8, 5 - 3, 7 - 1, 7 - 2	11-210 043-15	3 - 2	11-330 960-15	3 - 12
11-108 174-25	4 - 9	11-130 257-15	3 - 1	11-210 044-15	5 - 2	11-330 964-15	3 - 3, 3 - 4, 3 - 7, 3 - 8, 3 - 12, 3 - 13, 4 - 2, 4 - 4, 4 - 6, 4 - 8, 4 - 9, 10 - 1
11-108 177-15	4 - 1, 4 - 3 4 - 5, 4 - 10, 5 - 1, 6 - 3	11-130 281-25	13 - 2	11-210 081-15	5 - 3	11-335 280-15	3 - 7, 3 - 13, 6 - 3, 7 - 1
11-108 180-15	4 - 7, 7 - 4	11-130 284-15	6 - 3, 7 - 2	11-210 087-15	3 - 13	11-335 902-15	3 - 7, 3 - 12
11-108 186-15	5 - 2	11-130 287-15	3 - 8, 7 - 2, 7 - 3, 10 - 1, 10 - 2	11-210 165-15	6 - 1	11-340 283-15	7 - 1
11-108 186-25	13 - 2	11-130 293-15	3 - 8, 4 - 9, 4 - 10, 7 - 2, 10 - 2, 12 - 1	11-210 168-15	5 - 1	11-340 310-15	3 - 9
11-108 204-15	3 - 13	11-130 305-15	11 - 1	11-210 168-25	3 - 10, 4 - 8	11-341 166-15	4 - 9, 4 - 10, 7 - 2
11-108 219-15	3 - 1, 3 - 4, 3 - 5	11-130 311-15	6 - 3	11-210 210-15	3 - 1	11-341 217-15	4 - 8
11-108 222-15	3 - 1, 9 - 1	11-130 371-15	7 - 1	11-210 288-15	3 - 7	11-341 666-15	4 - 9, 4 - 10, 7 - 2
11-108 225-15	3 - 8, 10 - 2	11-130 906-15	3 - 1	11-250 084-25	3 - 10	11-341 217-15	4 - 8
11-108 228-15	3 - 1, 3 - 11	11-132 280-15	3 - 9	11-305 176-15	5 - 1	11-341 901-15	3 - 11, 4 - 2, 4 - 4, 4 - 6
11-108 234-15	3 - 1, 7 - 4	11-132 286-15	4 - 7	11-305 226-15	7 - 3	11-341 902-15	3 - 7, 3 - 11, 3 - 12, 7 - 3
11-108 237-15	7 - 2	11-132 286-15	4 - 7	11-314 280-15	7 - 2	11-341 904-15	6 - 3
11-108 246-15	3 - 1	11-135 292-15	10 - 3, 10 - 4	11-314 286-15	3 - 4	11-341 905-15	3 - 7, 3 - 12, 4 - 2, 4 - 4, 4 - 6, 4 - 8, 5 - 2, 6 - 3
11-108 285-15	3 - 1	11-173 168-15	5 - 2, 5 - 3	11-314 946-15	3 - 5, 5 - 2	11-343 176-15	4 - 2
11-108 294-15	3 - 2, 3 - 8, 5 - 2, 5 - 3, 7 - 2, 10 - 2	11-173 174-25	4 - 9	11-315 920-15	4 - 1	11-343 232-15	4 - 7
11-108 855-15	5 - 2	11-173 222-15	9 - 1	11-317 167-15	5 - 3	11-343 854-15	5 - 2
11-130 089-15	8 - 1	11-174 089-15	6 - 1	11-317 170-15	4 - 8	11-343 901-15	3 - 9
		11-174 089-25	4 - 7, 5 - 2, 5 - 3	11-330 085-15	4 - 2, 4 - 4, 4 - 6, 4 - 8	11-345 907-15	6 - 3
		11-174 167-15	10 - 3	11-330 094-15	4 - 2, 4 - 4, 4 - 6	11-460 163-15	13 - 7
		11-174 170-15	4 - 2, 4 - 4	11-330 166-15	3 - 4, 4 - 8		

No.	Seite Page Pages Página	No.	Seite Page Pages Página	No.	Seite Page Pages Página	No.	Seite Page Pages Página
11-460 250-15	13 - 7	12-499 150-45	5 - 1, 12 - 1, 13 - 4	12-664 350-45	4 - 2, 4 - 8, 10 - 3	14-016 151-91	3 - 7, 7 - 1
11-462 154-55	13 - 6	12-499 190-45	11 - 1	12-664 390-45	4 - 2, 4 - 4, 4 - 6	14-018 614-91	3 - 13
11-714 010-91	4 - 7	12-501 170-45	4 - 7	12-664 410-45	4 - 2, 4 - 4, 4 - 6, 4 - 8, 4 - 9, 5 - 1	14-018 624-91	3 - 13
12-005 154-15	3 - 13, 4 - 2, 4 - 9, 5 - 2	12-505 150-45	5 - 2	13-030 244-05	10 - 4	14-018 644-91	3 - 7
12-005 154-25	3 - 5, 3 - 6, 8 - 1	12-505 171-15	3 - 1	13-030 272-05	3 - 13	14-215 013-03	3 - 4
12-005 175-15	3 - 1, 4 - 7, 5 - 1, 6 - 1, 7 - 3, 10 - 1, 10 - 4	12-510 110-45	4 - 9, 7 - 4	13-030 310-05	3 - 9	14-215 025-33	4 - 7, 5 - 2
12-005 195-15	5 - 1	12-517 370-45	4 - 2, 4 - 4, 4 - 6	13-030 341-05	17 - 1	14-215 028-33	3 - 8, 3 - 13, 4 - 1
12-005 901-15	9 - 1	12-518 210-45	3 - 2	13-033 109-05	3 - 5, 3 - 6, 8 - 1	14-215 031-23	4 - 1, 4 - 3, 4 - 5
12-024 121-25	4 - 2, 4 - 4, 4 - 6	12-518 220-45	7 - 3	13-033 148-05	3 - 2	14-215 070-33	4 - 7
12-024 151-15	4 - 7, 5 - 3	12-610 190-45	7 - 4	13-033 193-05	6 - 2	14-215 106-23	4 - 1
12-024 151-25	7 - 4	12-610 210-45	3 - 4, 3 - 7, 5 - 2, 6 - 3	13-033 196-05	4 - 7	14-215 124-13	3 - 8
12-024 171-15	7 - 2, 10 - 1	12-610 250-45	3 - 9	13-033 244-05	4 - 6	14-215 124-43	3 - 4, 3 - 11
12-024 191-15	3 - 9, 10 - 4, 12 - 1	12-610 280-45	3 - 11	13-033 322-05	5 - 3	14-215 202-33	4 - 2, 4 - 4, 4 - 6
12-024 191-25	3 - 10	12-610 290-45	3 - 12, 4 - 7	13-033 382-05	4 - 7	14-218 030-01	4 - 7
12-305 084-15	4 - 7	12-610 370-45	3 - 8, 10 - 2	13-033 385-05	6 - 2	14-218 050-01	3 - 7
12-305 114-15	3 - 3, 3 - 13, 4 - 9, 5 - 2, 6 - 3, 7 - 4, 9 - 1, 10 - 3	12-610 380-45	3 - 13	13-033 385-05	6 - 2	14-602 901-01	3 - 10
12-305 144-15	3 - 1, 3 - 7, 4 - 7, 4 - 8, 7 - 1, 10 - 1	12-614 410-45	5 - 1	13-050 055-05	4 - 7	14-650 113-05	4 - 8
12-305 174-15	3 - 13, 4 - 6, 5 - 1	12-618 150-45	3 - 13	13-052 095-55	6 - 2	14-650 251-05	3 - 12
12-305 174-25	13 - 2	12-618 170-45	4 - 7	13-052 187-15	10 - 1	14-756 901-01	3 - 2, 10 - 1
12-315 070-15	5 - 2	12-618 190-45	7 - 4	13-052 193-15	5 - 1	15-032 001-45	12 - 1
12-315 080-15	3 - 3	12-618 210-45	4 - 7, 5 - 1	13-052 247-15	3 - 8	15-032 006-45	9 - 1
12-315 110-15	9 - 1	12-624 350-45	5 - 1	13-068 253-05	9 - 1	16-041 035-21	10 - 4
12-325 210-15	7 - 1	12-640 070-55	4 - 2, 4 - 4, 4 - 6	13-070 103-05	4 - 2, 4 - 4	16-409 972-05	3 - 7
12-315 140-25	5 - 3	12-640 090-55	4 - 7	13-070 981-05	14 - 1	16-409 975-05	7 - 1
12-315 170-15	4 - 9, 4 - 10	12-640 130-55	3 - 10, 7 - 2	13-250 097-25	5 - 1	16-415 433-05	14 - 1
12-316 110-15	5 - 1	12-640 150-55	3 - 3, 3 - 9, 3 - 13, 4 - 6, 4 - 7, 5 - 2	13-250 238-25	5 - 2	18-279 010-05	12 - 1
12-335 151-15	3 - 3, 7 - 4	12-640 170-55	4 - 7, 5 - 2	14-012 515-01	10 - 4	18-372 001-91	12 - 1
12-335 171-15	10 - 4	12-640 190-55	4 - 7, 10 - 4	14-012 551-01	5 - 1	18-372 008-91	9 - 1, 12 - 1
12-335 191-15	12 - 1	12-640 200-55	6 - 1, 7 - 2	14-012 555-01	4 - 2, 4 - 8, 5 - 2, 6 - 3, 10 - 3	18-378 001-91	12 - 1
12-360 062-05	3 - 7	12-640 210-55	3 - 2, 10 - 1	14-016 100-01	4 - 2, 4 - 4, 4 - 6, 4 - 7, 4 - 8, 4 - 9 5 - 1	18-378 002-91	12 - 1
		12-640 220-55	6 - 3	14-016 120-01	5 - 2, 6 - 3	18-378 008-91	9 - 1, 10 - 1, 10 - 4
		12-664 290-45	3 - 2, 10 - 1			25-308 820-30	9 - 1, 12 - 1

No.	Seite Page Pages Página	No.	Seite Page Pages Página	No.	Seite Page Pages Página	No.	Seite Page Pages Página
25-308 820-40	9 - 1, 12 - 1	71-590 007-21	13 - 4	91-011 165-04/014	5 - 3	91-020 490-15	3 - 9
25-308 820-60	9 - 1, 11 - 1, 12 - 1	71-590 007-31	13 - 5	91-011 166-04/001	5 - 3	91-021 041-05	5 - 2
26-536 301-59	3 - 1	71-590 007-32	13 - 3	91-011 166-04/002	5 - 3	91-021 123-05	9 - 1
28-011 201-44	19 - 1	91-000 390-05	4 - 1, 4 - 3, 4 - 5	91-011 166-04/003	5 - 3	91-021 124-15	7 - 2
28-011 202-05	19 - 1	91-000 529-15	4 - 1, 4 - 3, 4 - 5	91-011 166-04/004	5 - 3	91-023 505-25	3 - 5
28-011 202-17	19 - 1	91-000 928-15	4 - 1, 4 - 3, 4 - 5	91-011 179-04/001	6 - 2	91-025 874-05	3 - 3
28-011 202-43	19 - 1	91-002 065-05	3 - 5, 3 - 6, 8 - 1	91-011 179-04/002	6 - 2	91-027 289-15	14 - 1
28-011 202-47	19 - 1	91-002 262-25	3 - 5, 3 - 6, 8 - 1	91-011 179-04/003	6 - 2	91-027 370-05	14 - 1
61-111 600-01	17 - 1	91-003 113-05	5 - 1	91-011 179-04/004	6 - 2	91-027 371-12	14 - 1
61-111 600-35/001	17 - 1	91-004 005-05	3 - 5	91-011 179-04/011	6 - 2	91-027 846-75/698	3 - 1
61-111 639-49	17 - 1	91-004 006-05	3 - 5	91-011 179-04/012	6 - 2	91-029 450-15	17 - 1
70-374 500-02	5 - 1	91-004 188-05	3 - 5, 3 - 6, 8 - 1	91-011 179-04/013	6 - 2	91-029 692-75/792	14 - 1
71-130 001-04	6 - 3	91-009 149-05	6 - 3	91-011 179-04/014	6 - 2	91-029 931-75/699	17 - 1
71-130 001-11	4 - 7, 5 - 1	91-010 023-05	3 - 5, 8 - 1	91-011 194-72/895	6 - 3	91-029 933-71/699	17 - 1
71-130 004-39	13 - 2	91-010 038-05	3 - 5	91-011 233-04/001	5 - 3	91-029 934-71/699	17 - 1
71-130 004-40	13 - 2	91-010 039-05	3 - 5	91-011 233-04/011	5 - 3	91-046 140-05	4 - 7, 6 - 2
71-160 002-04	6 - 3	91-010 115-05	3 - 5	91-011 317-05	6 - 3	91-050 421-05	6 - 2
71-170 001-31	7 - 4	91-010 116-05	3 - 5	91-011 324-04/001	6 - 2	91-050 896-15	5 - 3
71-210 001-74	7 - 4	91-010 157-01	4 - 1, 4 - 3, 4 - 5	91-011 324-04/002	6 - 2	91-050 939-05	5 - 3, 6 - 1
71-370 001-08	13 - 7	91-010 159-91	4 - 1, 4 - 3, 4 - 5	91-011 324-04/003	6 - 2	91-054 876-15	3 - 3
71-370 001-32	7 - 4, 13 - 1	91-010 166-05	4 - 1, 4 - 3, 4 - 5	91-011 324-04/004	6 - 2	91-056 192-25	3 - 10
71-370 001-33	4 - 7	91-010 180-05	3 - 6, 8 - 1	91-011 324-04/011	6 - 2	91-056 193-25	3 - 10
71-370 001-35	5 - 3, 6 - 3	91-010 183-05	3 - 5, 3 - 6, 8 - 1	91-011 324-04/012	6 - 2	91-056 578-91	3 - 10
71-370 001-74	6 - 3	91-010 185-05	3 - 5, 3 - 6, 8 - 1	91-011 324-04/013	6 - 2	91-056 894-15	5 - 3
71-370 002-08	6 - 3	91-010 937-05	3 - 5, 8 - 1	91-011 324-04/014	6 - 2	91-056 895-15	5 - 3
71-370 002-23	5 - 1, 6 - 3	91-011 165-04/001	5 - 3	91-011 387-04/001	6 - 2	91-056 896-15	5 - 3
71-370 002-92	13 - 7	91-011 165-04/002	5 - 3	91-011 387-04/002	6 - 2	91-056 897-15	5 - 3
71-370 003-06	13 - 2	91-011 165-04/003	5 - 3	91-011 387-04/003	6 - 2	91-056 898-15	5 - 3
71-370 003-09	13 - 6	91-011 165-04/004	5 - 3	91-011 387-04/004	6 - 2	91-056 899-05	5 - 3
71-520 002-18	5 - 3, 6 - 3	91-011 165-04/011	5 - 3	91-011 391-05	3 - 1	91-056 900-05	5 - 3
71-520 006-01	13 - 4	91-011 165-04/012	5 - 3	91-017 378-15	4 - 7, 5 - 2	91-056 902-15	5 - 3
71-520 006-02	13 - 3	91-011 165-04/013	5 - 3	91-018 293-05	4 - 1, 4 - 3, 4 - 5	91-056 903-05	5 - 3

No.	Seite Page Pages Página	No.	Seite Page Pages Página	No.	Seite Page Pages Página	No.	Seite Page Pages Página
91-056 904-05	5 - 3	91-100 381-15	4 - 2, 4 - 8, 10 - 3	91-118 612-05	3 - 13	91-119 087-05	3 - 2, 3 - 11, 4 - 7, 6 - 3, 10 - 1
91-056 906-15	5 - 3	91-100 393-15	5 - 2	91-118 681-05	3 - 10	91-119 093-21	3 - 5, 3 - 6, 8 - 1
91-063 049-05	6 - 3	91-100 396-15	4 - 1, 4 - 3, 4 - 5	91-118 683-05	3 - 10	91-119 103-05	4 - 2, 4 - 4, 4 - 6
91-063 117-01	6 - 3	91-101 775-05	17 - 1	91-118 685-05	3 - 10	91-119 105-15	4 - 1, 4 - 3, 4 - 5
91-063 118-05	6 - 3	91-101 921-15	3 - 13	91-118 722-12	3 - 13	91-119 107-92	4 - 2, 4 - 4, 4 - 6
91-069 037-15	3 - 13	91-105 447-25	3 - 5, 3 - 6, 8 - 1	91-118 724-91	3 - 13	91-119 109-90	4 - 2
91-069 079-72/895	3 - 3	91-107 233-05	6 - 3	91-118 726-12	3 - 13	91-119 111-05	4 - 2, 4 - 8, 10 - 3
91-069 335-72/893	14 - 1	91-107 235-05	6 - 3	91-118 857-05	3 - 9	91-119 112-01	4 - 2, 4 - 8, 10 - 3
91-069 471-25	3 - 5, 3 - 6, 8 - 1	91-107 238-05	6 - 3	91-118 858-15	3 - 9	91-119 115-01	4 - 2, 4 - 8, 10 - 3
91-088 273-91	13 - 2	91-107 249-45	6 - 3	91-118 893-92	3 - 11	91-119 116-91	4 - 2, 4 - 8
91-088 275-21	13 - 2	91-107 265-05	4 - 7	91-118 940-05	3 - 10	91-119 119-05	3 - 6, 8 - 1
91-089 095-91	13 - 2	91-107 266-05	6 - 2, 6 - 3	91-119 004-05	3 - 3	91-119 120-91	4 - 9
91-089 096-25	13 - 2	91-107 277-91	6 - 3	91-119 013-92	3 - 4	91-119 121-12	4 - 9
91-090 226-91	7 - 4	91-118 099-91	3 - 10	91-119 014-05	3 - 4	91-119 128-05	4 - 1, 4 - 3, 4 - 5
91-090 227-45	7 - 4	91-118 196-12	3 - 4	91-119 015-15	3 - 4	91-119 129-05	4 - 1, 4 - 3, 4 - 5
91-093 063-05	13 - 2	91-118 308-05	4 - 1, 4 - 3, 4 - 5	91-119 016-05	3 - 3	91-119 133-90	4 - 2, 4 - 4, 4 - 6
91-094 368-91	13 - 6	91-118 430-25	3 - 5	91-119 018-02	3 - 3	91-119 136-05	4 - 9, 4 - 10
91-094 437-71/895	6 - 3	91-118 504-92	3 - 4, 3 - 8	91-119 019-05	3 - 3	91-119 138-05	4 - 9, 4 - 10
91-094 446-71/895	13 - 6	91-118 518-05	3 - 4	91-119 023-15	3 - 5, 3 - 6, 8 - 1	91-119 140-91	4 - 2, 4 - 4
91-094 483-91	4 - 7, 5 - 1	91-118 520-05	3 - 4	91-119 024-15	3 - 5, 3 - 6, 8 - 1	91-119 141-25	4 - 2, 4 - 4
91-095 103-91	13 - 7	91-118 521-15	3 - 4	91-119 027-25	3 - 5	91-119 142-25	4 - 2, 4 - 4
91-097 074-45	17 - 1	91-118 535-05	3 - 9	91-119 039-72/895	3 - 1	91-119 143-05	4 - 2, 4 - 4
91-100 050-15	6 - 3	91-118 539-05	3 - 3	91-119 042-91	3 - 8	91-119 150-91	3 - 2, 10 - 1
91-100 205-15	4 - 1, 4 - 3, 4 - 5	91-118 553-05	3 - 5	91-119 045-91	3 - 8	91-119 158-15	3 - 2, 10 - 1
91-100 211-15	5 - 2	91-118 568-91	3 - 9	91-119 046-91	3 - 8	91-119 159-05	3 - 2, 10 - 1
91-100 270-25	4 - 6	91-118 570-92	3 - 7	91-119 049-05	3 - 4	91-119 162-11	3 - 2, 3 - 11, 10 - 1
91-100 281-25	3 - 10	91-118 577-11	3 - 3	91-119 056-05	3 - 13	91-119 163-12	3 - 2, 3 - 11, 10 - 1
91-100 289-15	7 - 3	91-118 594-15	3 - 4	91-119 059-05	3 - 13	91-119 164-12	3 - 2, 3 - 11, 10 - 1
91-100 296-25	4 - 9, 4 - 10	91-118 596-05	3 - 4	91-119 081-91	3 - 12	91-119 165-15	3 - 3
91-100 300-15	6 - 1	91-118 600-91	3 - 4, 3 - 8, 3 - 11	91-119 084-05	3 - 11	91-119 174-01	5 - 1
91-100 331-15	3 - 9	91-118 603-91	3 - 11	91-119 085-05	3 - 2, 3 - 11, 10 - 1	91-119 177-15	5 - 1
91-100 381-05	4 - 8	91-118 610-02	3 - 8, 10 - 2			91-119 178-91	5 - 2

No.	Seite Page Pages Página	No.	Seite Page Pages Página	No.	Seite Page Pages Página	No.	Seite Page Pages Página
91-119 179-05	5 - 2	91-119 257-12	7 - 2	91-119 390-05	4 - 2	91-119 534-05	4 - 8
91-119 182-15	5 - 2	91-119 258-05	7 - 3	91-119 402-05	5 - 3	91-119 535-92	4 - 8
91-119 185-92	5 - 2	91-119 259-91	7 - 3	91-119 408-05	4 - 1, 4 - 3, 4 - 5	91-119 544-05	4 - 8
91-119 186-05	5 - 2	91-119 260-15	7 - 3	91-119 409-75/895	5 - 1	91-119 546-05	4 - 8
91-119 187-05	5 - 2	91-119 261-05	7 - 3	91-119 436-91	4 - 2, 4 - 4	91-119 565-05	4 - 7
91-119 188-15	5 - 2	91-119 266-05	7 - 2	91-119 437-25	4 - 2, 4 - 4	91-119 566-05	4 - 7
91-119 189-71/951	5 - 2	91-119 269-91	3 - 13	91-119 442-05	7 - 2	91-119 570-15	4 - 7
91-119 190-71/951	5 - 2	91-119 271-92	4 - 2, 4 - 4, 4 - 6	91-119 443-05	7 - 3	91-119 573-25	4 - 7
91-119 193-21	5 - 2	91-119 279-15	4 - 2, 4 - 4, 4 - 6	91-119 444-04/001	5 - 3	91-119 576-15	4 - 7
91-119 196-15	5 - 2	91-119 281-92	4 - 2, 4 - 4, 4 - 6	91-119 444-04/011	5 - 3	91-119 578-12	4 - 7
91-119 198-05	5 - 2	91-119 282-05	4 - 9, 4 - 10	91-119 446-92	7 - 3	91-119 580-05	4 - 7
91-119 199-12	5 - 2	91-119 296-74/005	4 - 10	91-119 448-92	7 - 2	91-119 581-92	4 - 7
91-119 200-75/895	5 - 3	91-119 296-74/006	4 - 10	91-119 449-12	7 - 3	91-119 582-05	4 - 7
91-119 201-71/895	5 - 1	91-119 296-74/007	4 - 10	91-119 451-11	7 - 4	91-119 587-92	4 - 7
91-119 202-04/001	5 - 2, 5 - 3	91-119 296-74/008	4 - 10	91-119 455-01	4 - 9, 4 - 10	91-119 588-15	4 - 7
91-119 202-04/011	5 - 3	91-119 296-74/009	4 - 10	91-119 458-91	4 - 1, 4 - 3, 4 - 5	91-119 589-04/001	4 - 7
91-119 214-05	5 - 2	91-119 300-74/001	4 - 10	91-119 469-05	3 - 2	91-119 590-05	4 - 7
91-119 218-71/895	4 - 9	91-119 300-74/002	4 - 10	91-119 478-93/001	3 - 2	91-119 596-11	4 - 7
91-119 219-71/895	4 - 9	91-119 300-74/003	4 - 10	91-119 487-01	4 - 1, 4 - 3, 4 - 5	91-119 605-25	4 - 6
91-119 223-05	7 - 2	91-119 300-74/004	4 - 10	91-119 491-05	3 - 2	91-119 607-15	4 - 6
91-119 226-05	7 - 2	91-119 300-74/005	4 - 10	91-119 492-91	4 - 2, 4 - 4, 4 - 6	91-119 613-75/951	5 - 3
91-119 231-02	7 - 2	91-119 300-74/006	4 - 10	91-119 493-15	5 - 2	91-119 670-11	4 - 8
91-119 234-91	4 - 1, 4 - 3, 4 - 5	91-119 300-74/007	4 - 10	91-119 494-92	4 - 1	91-119 671-05	4 - 6
91-119 236-05	7 - 2	91-119 326-05	7 - 2	91-119 496-12	5 - 3	91-119 681-93/001	3 - 2
91-119 237-05	7 - 2, 7 - 3	91-119 328-92	7 - 2	91-119 502-91	3 - 2	91-119 697-05	5 - 2
91-119 242-15	7 - 4	91-119 354-15	7 - 3	91-119 503-05	3 - 2	91-119 704-91	3 - 7
91-119 243-05	7 - 4	91-119 373-05	4 - 10	91-119 506-01	3 - 2, 10 - 1	91-119 705-12	3 - 7
91-119 250-05	7 - 3	91-119 377-05	4 - 1, 4 - 3, 4 - 5	91-119 507-91	3 - 2, 10 - 1	91-119 714-05	5 - 3
91-119 251-92	7 - 3	91-119 380-92	4 - 1, 4 - 3, 4 - 5	91-119 509-11	3 - 8	91-119 715-05	5 - 3
91-119 253-05	7 - 3	91-119 381-05	4 - 1, 4 - 3, 4 - 5	91-119 521-92	3 - 11	91-119 716-91	4 - 1, 4 - 3, 4 - 5
91-119 255-12	7 - 3	91-119 385-91	4 - 1, 4 - 3, 4 - 5	91-119 532-05	4 - 8	91-119 722-91	4 - 8
91-119 256-05	7 - 3	91-119 386-91	4 - 1, 4 - 3, 4 - 5	91-119 533-05	4 - 8	91-119 723-05	4 - 8

No.	Seite Page Pages Página	No.	Seite Page Pages Página	No.	Seite Page Pages Página	No.	Seite Page Pages Página
91-119 724-05	4 - 8	91-119 922-91	4 - 7	91-125 009-05	4 - 2	91-164 634-05	10 - 4
91-119 725-05	4 - 8	91-119 923-05	4 - 7	91-129 915-01	5 - 3, 6 - 2	91-164 635-05	10 - 1
91-119 733-25	4 - 2, 4 - 4	91-119 924-75/895	4 - 7	91-129 917-91	19 - 1	91-164 636-05	4 - 8
91-119 734-05	4 - 9, 4 - 10	91-119 925-75/895	4 - 7	91-129 919-91	19 - 1	91-164 637-05	10 - 4
91-119 737-00	4 - 8	91-119 926-05	4 - 7	91-129 920-91	19 - 1	91-164 638-72/895	10 - 2
91-119 742-91	4 - 1, 4 - 3	91-119 927-71/951	4 - 7	91-129 941-91	19 - 1	91-164 640-75/895	10 - 2
91-119 743-71/951	7 - 2	91-119 928-75/951	4 - 7	91-133 109-05	3 - 12	91-164 641-71/951	10 - 4
91-119 748-72/951	7 - 2	91-119 929-05	4 - 7	91-141 688-90	13 - 3	91-164 642-91	10 - 2
91-119 749-05	4 - 2, 4 - 4, 4 - 6	91-119 930-05	4 - 7	91-156 114-05	5 - 3	91-164 643-91	10 - 1
91-119 750-05	7 - 2	91-119 931-01	4 - 7	91-156 262-91	5 - 3	91-164 661-71/893	12 - 1
91-119 751-15	7 - 2	91-119 932-05	4 - 7	91-162 526-05	3 - 12	91-164 671-92	10 - 2
91-119 752-92	7 - 2	91-119 933-05	4 - 7	91-164 015-75/895	4 - 8	91-164 672-91	4 - 9, 4 - 10
91-119 753-92	7 - 2	91-119 934-12	4 - 7	91-164 037-91	3 - 9	91-164 673-01	4 - 9, 4 - 10
91-119 754-92	7 - 2	91-119 936-05	4 - 7	91-164 092-05	4 - 7	91-164 677-91	4 - 10
91-119 755-92	7 - 2	91-119 937-71/895	4 - 6	91-164 105-75/895	6 - 3	91-164 678-71/698	8 - 1
91-119 763-05	3 - 4	91-119 938-71/895	4 - 6	91-164 107-75/951	6 - 3	91-164 679-71/698	8 - 1
91-119 767-91	4 - 1, 4 - 3	91-119 940-01	3 - 4	91-164 127-71/895	4 - 4	91-164 680-15	8 - 1
91-119 770-91	4 - 2, 4 - 4	91-119 942-93/001	3 - 2	91-164 128-75/895	4 - 4	91-164 681-15	8 - 1
91-119 787-93/001	3 - 2	91-119 950-05	4 - 2, 4 - 4, 4 - 6	91-164 129-15	7 - 2	91-164 682-91	4 - 2, 4 - 4, 4 - 6
91-119 795-11	4 - 8	91-119 953-15	3 - 2	91-164 181-71/895	4 - 2, 4 - 4	91-164 683-05	4 - 2, 4 - 4, 4 - 6
91-119 798-93/001	3 - 2	91-119 954-15	3 - 2	91-164 183-75/895	4 - 2, 4 - 4	91-164 685-25	3 - 5
91-119 802-91	3 - 2	91-119 956-15	3 - 2	91-164 243-71/895	6 - 2	91-164 686-71/698	8 - 1
91-119 803-91	3 - 2	91-119 957-05	4 - 2	91-164 315-15	3 - 1	91-164 687-71/698	8 - 1
91-119 807-15	3 - 2	91-119 958-05	4 - 2	91-164 384-05	3 - 1	91-164 688-05	3 - 6, 8 - 1
91-119 869-05	4 - 2, 4 - 8, 10 - 3	91-119 959-05	4 - 2, 4 - 8, 10 - 3	91-164 527-71/893	14 - 1	91-164 691-71/698	3 - 5
91-119 885-05	6 - 1	91-119 960-05	4 - 2, 4 - 8, 10 - 3	91-164 624-92	3 - 8, 10 - 2	91-164 692-71/698	3 - 5
91-119 886-05	3 - 2, 10 - 1	91-119 961-05	3 - 2, 10 - 1	91-164 626-05	10 - 4	91-164 693-71/698	3 - 6
91-119 895-01	4 - 10	91-119 962-05	3 - 2, 10 - 1	91-164 627-05	10 - 1	91-164 694-71/698	3 - 6
91-119 899-91	4 - 1, 4 - 3	91-119 984-15	7 - 4	91-164 628-75/951	10 - 4	91-164 698-05	10 - 4
91-119 917-91	4 - 7	91-122 718-05	4 - 2	91-164 629-05	10 - 1	91-164 700-75/895	4 - 10
91-119 918-12	4 - 7	91-122 934-15	7 - 2	91-164 630-91	10 - 1	91-164 748-15	3 - 1
91-119 919-91	4 - 7	91-125 008-05	4 - 2	91-164 633-92	10 - 1	91-164 777-91	3 - 7

No.	Seite Page Pages Página	No.	Seite Page Pages Página	No.	Seite Page Pages Página	No.	Seite Page Pages Página
91-164 778-91	3 - 7	91-165 438-91	9 - 1	91-171 542-91	9 - 1, 14 - 1	91-175 136-05	4 - 1, 4 - 3, 4 - 5
91-164 781-15	3 - 7	91-165 440-91	3 - 4	91-171 543-05	9 - 1, 14 - 1	91-175 137-05	4 - 1, 4 - 3
91-164 784-75/698	3 - 1	91-165 444-91	3 - 7	91-171 544-12	9 - 1, 14 - 1	91-175 138-01	4 - 2, 4 - 4, 4 - 6
91-164 785-75/698	3 - 1	91-165 445-91	3 - 7	91-172 910-05	9 - 1	91-175 148-12	6 - 3
91-164 786-75/698	3 - 1	91-165 447-90	4 - 8	91-173 029-05	3 - 4	91-175 150-05	3 - 8
91-164 789-75/698	3 - 1	91-166 279-11	9 - 1	91-173 505-05	3 - 13	91-175 151-11	6 - 2
91-164 899-75/895	6 - 3	91-166 339-91	9 - 1	91-174 783-05	3 - 10	91-175 154-12	6 - 3
91-164 902-01	3 - 4	91-166 452-21	3 - 10	91-174 879-05	3 - 10	91-175 155-11	6 - 2
91-164 903-91	3 - 4	91-166 493-05	3 - 4	91-175 004-91	4 - 7	91-175 158-12	6 - 3
91-164 960-71/698	3 - 1	91-166 551-91	3 - 12	91-175 017-71/895	4 - 7	91-175 159-05	6 - 3
91-164 963-71/698	3 - 1	91-166 552-02	3 - 12	91-175 019-92	3 - 12	91-175 160-15	6 - 2
91-164 965-71/698	3 - 1	91-166 553-05	3 - 12	91-175 027-15	3 - 3	91-175 161-11	6 - 2
91-165 342-05	4 - 1, 4 - 3, 4 - 5	91-166 554-05	3 - 12	91-175 038-91	3 - 13	91-175 166-75/951	5 - 2
91-165 343-05	4 - 1, 4 - 3, 4 - 5	91-166 555-92	3 - 12	91-175 044-05	3 - 13	91-175 167-75/951	5 - 2
91-165 344-15	4 - 10	91-166 670-15	13 - 3	91-175 045-05	3 - 13	91-175 168-12	5 - 2, 6 - 3
91-165 354-91	6 - 3	91-166 824-05	3 - 4	91-175 046-05	3 - 13	91-175 169-15	5 - 2
91-165 357-15	3 - 13	91-166 879-91	9 - 1	91-175 047-12	3 - 7	91-175 170-12	5 - 2, 6 - 3
91-165 358-11	3 - 13	91-167 636-05	7 - 4	91-175 048-12	3 - 7	91-175 171-05	5 - 2
91-165 364-05	3 - 13	91-168 024-05	7 - 2	91-175 049-12	3 - 7	91-175 175-05	5 - 2
91-165 365-05	3 - 13	91-168 061-75/893	3 - 1	91-175 102-91	4 - 7	91-175 179-15	6 - 2
91-165 372-71/893	3 - 1	91-168 194-71/698	3 - 5, 3 - 6, 8 - 1	91-175 103-15	4 - 7	91-175 180-15	6 - 2
91-165 373-05	3 - 1	91-168 218-91	6 - 1	91-175 104-12	4 - 7	91-175 181-15	6 - 2
91-165 374-75/893	3 - 1	91-168 351-05	4 - 2, 4 - 8	91-175 105-05	4 - 7	91-175 183-91	3 - 13
91-165 375-91	3 - 5	91-168 480-15	3 - 7	91-175 106-05	4 - 7	91-175 184-90	3 - 13
91-165 376-91	3 - 5	91-169 137-05	3 - 8	91-175 108-90	3 - 2	91-175 187-01	3 - 13
91-165 377-25	3 - 5	91-169 523-15	3 - 1	91-175 109-90	3 - 2	91-175 189-01	3 - 13
91-165 405-25	4 - 6	91-170 286-05	5 - 1	91-175 112-71/895	4 - 7	91-175 224-15	5 - 1
91-165 408-15	3 - 1	91-170 913-72/893	3 - 7	91-175 113-90	4 - 8	91-175 225-91	4 - 4
91-165 415-15	9 - 1	91-171 042-05	3 - 10	91-175 116-71/895	5 - 1	91-175 226-25	4 - 4
91-165 417-01	4 - 2, 4 - 4, 4 - 6	91-171 049-05	3 - 10	91-175 117-05	5 - 1	91-175 227-25	4 - 6
91-165 419-01	4 - 1	91-171 175-12	3 - 12	91-175 118-15	5 - 1	91-175 228-25	4 - 6
91-165 437-92	9 - 1	91-171 412-71/893	14 - 1	91-175 127-91	3 - 4	91-175 248-05	6 - 2

No.	Seite Page Pages Página	No.	Seite Page Pages Página	No.	Seite Page Pages Página	No.	Seite Page Pages Página
91-175 249-12	6 - 2	91-175 348-15	6 - 1	91-229 070-70/895	16 - 1	91-263 027-71/895	4 - 8
91-175 250-91	6 - 3	91-175 349-01	6 - 1	91-229 071-71/895	16 - 1	91-263 028-71/895	4 - 8
91-175 253-15	6 - 3	91-175 350-05	6 - 1	91-229 072-45	16 - 1	91-263 031-71/895	4 - 8
91-175 254-15	6 - 3	91-175 351-05	6 - 1	91-229 073-71/895	16 - 1	91-263 032-71/895	4 - 8
91-175 255-15	6 - 3	91-175 352-05	6 - 1	91-229 074-05	16 - 1	91-263 035-75/895	4 - 4
91-175 256-75/895	6 - 3	91-175 355-91	3 - 3	91-229 075-45	16 - 1	91-263 036-75/895	4 - 6
91-175 257-75/895	6 - 2	91-175 356-01	3 - 3	91-229 076-75/698	16 - 1	91-263 037-75/895	4 - 8
91-175 258-91	6 - 1	91-175 358-05	3 - 9	91-229 077-72/895	16 - 1	91-263 049-75/895	4 - 9
91-175 259-15	6 - 1	91-175 597-91	5 - 2	91-229 078-25	16 - 1	91-263 050-71/895	4 - 2
91-175 260-15	6 - 1	91-175 598-15	5 - 2	91-229 078-45	16 - 1	91-263 052-71/895	4 - 2
91-175 262-91	6 - 1	91-175 599-05	5 - 2	91-229 079-25	16 - 1	91-263 053-71/895	4 - 2
91-175 263-15	6 - 1	91-175 600-15	5 - 2	91-229 080-25	16 - 1	91-263 054-71/895	4 - 2
91-175 264-15	6 - 1	91-175 776-93/001	3 - 2	91-229 081-25	16 - 1	91-263 055-71/895	4 - 2
91-175 272-05	4 - 1, 4 - 3, 4 - 5	91-176 302-05	3 - 4	91-229 082-25	16 - 1	91-263 056-71/895	4 - 2
91-175 283-01	4 - 1, 4 - 3, 4 - 5	91-176 315-05	3 - 4	91-229 123-25	16 - 1	91-263 057-71/895	4 - 4
91-175 310-05	4 - 2, 4 - 4, 4 - 6	91-176 319-05	3 - 5, 3 - 6, 8 - 1	91-229 124-25	16 - 1	91-263 058-71/895	4 - 4
91-175 311-05	4 - 1	91-176 332-25	3 - 5	91-229 125-25	16 - 1	91-263 059-71/895	4 - 4
91-175 312-05	4 - 1	91-176 354-25	3 - 5, 3 - 6, 8 - 1	91-229 126-25	16 - 1	91-263 060-71/895	4 - 4
91-175 313-05	4 - 2, 4 - 4, 4 - 6	91-176 355-25	3 - 5, 3 - 6, 8 - 1	91-229 127-25	16 - 1	91-263 061-71/895	4 - 7
91-175 314-05	4 - 1	91-176 356-25	3 - 5, 3 - 6, 8 - 1	91-229 128-25	16 - 1	91-263 062-71/895	4 - 7
91-175 315-05	4 - 1, 4 - 3, 4 - 5	91-177 006-05	10 - 1	91-229 129-25	16 - 1	91-263 063-75/895	4 - 2
91-175 318-05	4 - 2, 4 - 4, 4 - 6	91-177 464-75/893	12 - 1	91-262 195-92	3 - 7	91-263 064-75/895	4 - 4
91-175 321-05	4 - 2, 4 - 4, 4 - 6	91-177 733-05	10 - 1	91-262 385-75/893	13 - 4	91-263 065-75/895	4 - 6
91-175 325-05	4 - 3, 4 - 5	91-182 360-15	10 - 4	91-263 004-71/893	3 - 13	91-263 066-71/895	5 - 2
91-175 328-92	4 - 4, 4 - 6	91-186 620-15	14 - 1	91-263 005-71/893	3 - 13	91-263 067-75/895	5 - 1
91-175 329-05	4 - 1, 4 - 3	91-187 293-75/893	11 - 1	91-263 007-75/895	3 - 1	91-263 068-05	3 - 12
91-175 333-92	4 - 1, 4 - 3, 4 - 5	91-187 386-75/893	11 - 1	91-263 008-92	3 - 3	91-263 073-71/895	4 - 4
91-175 334-71/895	4 - 6	91-187 426-70/893	11 - 1	91-263 021-71/895	4 - 4	91-263 075-15	3 - 1
91-175 335-71/895	4 - 6	91-229 014-75/699	17 - 1	91-263 022-71/895	4 - 7	91-263 081-71/895	4 - 2
91-175 337-71/895	4 - 6	91-229 015-75/699	17 - 1	91-263 023-71/895	4 - 4	91-263 083-71/895	4 - 2
91-175 338-71/895	4 - 6	91-229 068-75/895	16 - 1	91-263 025-71/895	4 - 4	91-263 084-91	10 - 3
91-175 339-71/895	4 - 6	91-229 069-75/895	16 - 1	91-263 026-71/895	4 - 7	91-263 086-05	3 - 12

Index (Teilenummern / Seitenzahlen)

Index (part numbers / page numbers)

Index (numéros de pièces, de pages)

Index (números de pieza / números de página)

PFAFF 471

PFAFF 474

PFAFF 491

20

No.	Seite Page Pages Página	No.	Seite Page Pages Página	No.	Seite Page Pages Página	No.	Seite Page Pages Página
91-263 087-05	7 - 1	95-655 735-91	19 - 1				
91-263 087-92	7 - 1	96-700 333-15	4 - 4, 4 - 6				
91-263 088-92	7 - 1	99-133 116-01	3 - 2				
91-263 091-05	7 - 1	99-133 283-15	3 - 4, 3 - 8, 3 - 11				
91-263 095-91	10 - 3	99-133 752-01	12 - 1				
91-263 097-91	10 - 3	99-134 206-05	9 - 1, 12 - 1				
91-263 113-90	4 - 2	99-134 255-91	9 - 1, 12 - 1				
91-266 114-15	3 - 1	99-134 256-91	9 - 1, 12 - 1				
91-266 397-01	3 - 10	99-134 370-91	12 - 1				
91-266 520-92	3 - 13	99-134 437-91	12 - 1				
91-291 133-91	8 - 1	99-134 792-05	3 - 1				
91-291 442-91	13 - 7	99-135 002-95	12 - 1				
91-291 728-91	13 - 1	99-135 911-91	10 - 2, 12 - 1				
91-700 017-15	3 - 3	99-136 310-05	9 - 1				
91-700 034-15	5 - 1	99-136 330-91	9 - 1				
91-700 082-15	3 - 5	99-136 546-91	11 - 1				
91-700 087-15	5 - 2	99-136 600-91	10 - 1, 10 - 2, 10 - 4				
91-700 249-15	4 - 9, 4 - 10	99-136 849-55	3 - 1				
91-700 324-05	3 - 3	99-136 854-55	13 - 4, 13 - 5				
91-700 335-25	3 - 1, 4 - 2, 4 - 4, 4 - 6, 4 - 8, 5 - 1, 10 - 2	99-137 151-45	3 - 10				
91-700 363-15	4 - 9	99-137 196-05	13 - 4				
91-700 364-25	8 - 1	99-137 281-91	10 - 3				
91-700 366-25	3 - 5, 3 - 6, 8 - 1						
91-700 388-15	3 - 5, 3 - 7						
91-700 412-25	3 - 5, 6 - 2						
91-700 510-15	3 - 7, 4 - 7, 5 - 2						
91-700 689-15	4 - 1, 4 - 7, 5 - 2						
91-700 785-15	3 - 3, 4 - 8						
91-701 344-15	3 - 4						
91-701 344-25	4 - 7						
91-701 522-25	3 - 5, 3 - 6, 8 - 1						

PFAFF

G.M. PFAFF
Aktiengesellschaft

Postfach 3020
D-67653 Kaiserslautern

Königstr. 154
D-67655 Kaiserslautern

Telefon: (0631) 200-0
Telefax: (0631) 172 02
Telex: 45753 PFAFF D

Gedruckt in der BRD
Printed in Germany
Imprimé en R.F.A.
Impreso en la R.F.A.

471

474

Unterklassen-Ausstattung

Subclass parts

Composition des sous-classes

Composición de las subclases

491

21.01

Nähwerkzeuge[▲]
Gauge parts
Organes de couture
Organos de costura

PFAFF 471

Zum Herstellen von Zier- und Befestigungsnähten an feinen Materialien.
(Ausführung A*)

For sewing fancy seams and assembly seams on lightweight materials.
(Model A*)

Pour les coutures d'ornementation et de fixation sur matières fines.
(version A*)

Para ejecutar costuras de adorno y de fijación de materiales ligeros.
(Tipo A*)

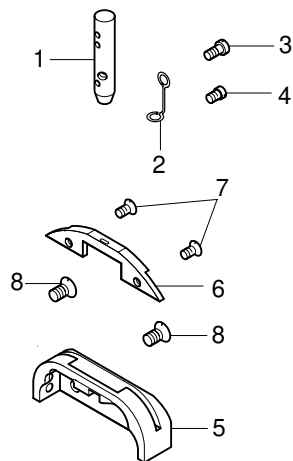

Pos.-Nr. Item No. N° pos. N° de pos.	Teil-Nr. Part No. N° de piezas N° de pieza
1	91-175 097-05
2	91-175 098-05
3	11-108 093-15
4	91-173 664-15
5 - 7	91-150 266-93/002
5	91-150 189-05
6	91-150 267-04/003
7	11-210 038-15
8	91-100 296-25

Zum Herstellen von Zier- und Befestigungsnähten an feinen Materialien.
(Ausführung -900/53 A*)

For sewing fancy seams and assembly seams on lightweight materials.
(Model -900/53 A*)

Pour les coutures d'ornementation et de fixation sur matières fines.
(version -900/53 A*)

Para ejecutar costuras de adorno y de fijación de materiales ligeros.
(Tipo -900/53 A*)

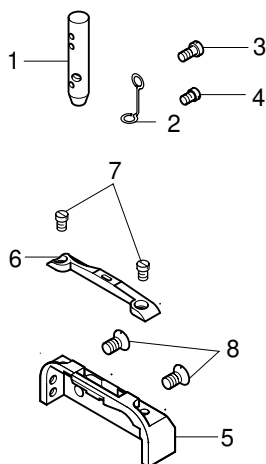

Pos.-Nr. Item No. N° pos. N° de pos.	Teil-Nr. Part No. N° de piezas N° de pieza
1	91-175 097-05
2	91-175 098-05
3	11-108 093-15
4	91-173 664-15
5 - 7	91-150 605-93/003
5	91-150 603-05
6	91-150 265-04/009
7	11-174 086-15
8	91-100 296-25

Zum Herstellen von Zier- und Befestigungsnähten an mittleren Materialien.
 (Ausführung B*)

For sewing fancy seams and assembly seams on medium-weight materials.
 (Model B*)

Pour les coutures d'ornementation et de fixation sur matières moyennes.
 (version B*)

Para ejecutar costuras de adorno y de fijación de materiales medianos.
 (Tipo B*)

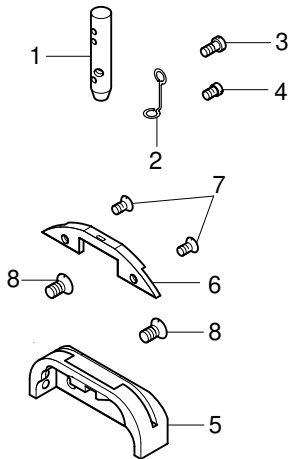

Pos.-Nr. Item No. N° pos. N° de pos.	Teile-Nr. Part No. N° de piezas N° de pieza
1	91-175 097-05
2	91-175 098-05
3	11-108 093-15
4	91-173 664-15
5 - 7	91-150 337-93/002
5	91-150 189-05
6	91-150 338-04/008
7	11-210 038-15
8	91-100 296-25

Zum Herstellen von Zier- und Befestigungsnähten an mittleren Materialien
 (Ausführung -900/53 B*)

For sewing fancy seams and assembly seams on medium-weight materials.
 (Model -900/53 B*)

Pour les coutures d'ornementation et de fixation sur matières moyennes.
 (version -900/53 B*)

Para ejecutar costuras de adorno y de fijación de materiales medianos.
 (Tipo -900/53 B*)

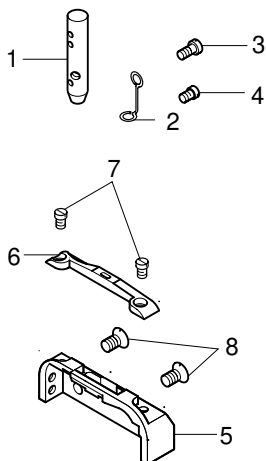

Pos.-Nr. Item No. N° pos. N° de pos.	Teile-Nr. Part No. N° de piezas N° de pieza
1	91-175 097-05
2	91-175 098-05
3	11-108 093-15
4	91-173 664-15
5 - 7	91-150 606-93/002
5	91-150 603-05
6	91-150 336-04/007
7	11-174 086-15
8	91-100 296-25

-59/01 A[◆]
-59/01 B[◆]

Arbeitsgang
Operation
Opération
Opéración

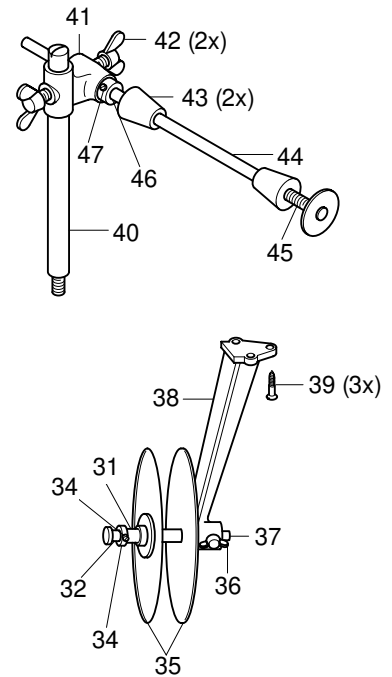
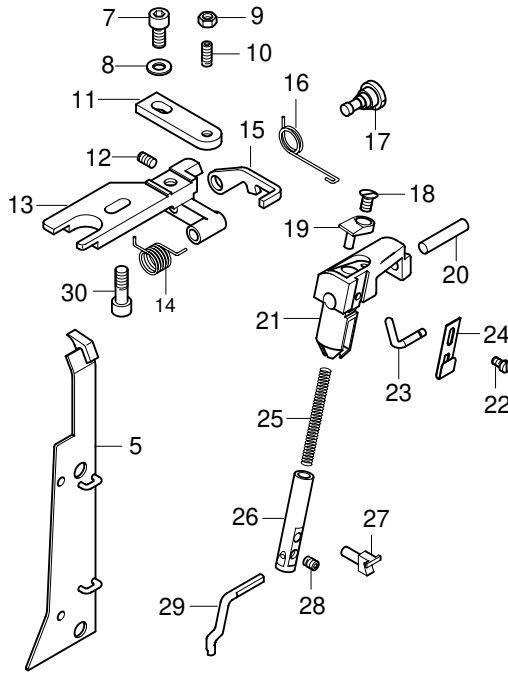
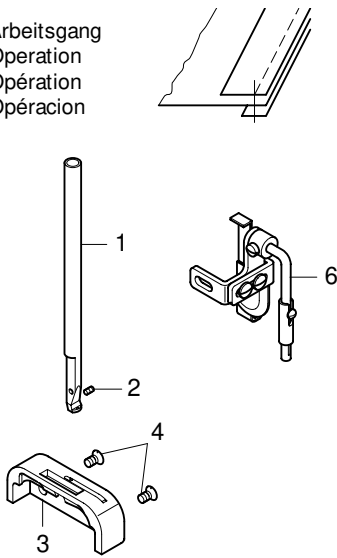

Pos.-Nr. Item No. N° pos. N° de pos.	Ausführung Model Version Tipo	Bandbreite Tape width Largeur de bande Ancho de la cinta	Teile-Nr. Part No. N° de piezas N° de pieza
1 - 2			91-119 440-91
2			11-330 082-15
3	A A B B	2,0 2,5 2,0 2,5	91-150 364-03/001 91-150 364-03/003 91-150 364-03/002 91-150 364-03/004
4			91-100 296-25
5			91-053 984-21
6			91-050 859-91
7 - 28			91-156 262-91
7			11-130 224-15
8			12-315 140-25
9			12-024 151-15
10			11-330 175-15
11			91-056 896-15
12			11-317 167-15
13			91-056 895-15
14			91-056 903-05
15			91-056 897-15
16			91-056 904-05
17			91-050 896-15
18			11-210 081-15
19			91-056 902-15
20			13-033 322-05
21			91-056 894-15
22			11-108 084-15
23			91-056 898-15

Pos.-Nr. Item No. N° pos. N° de pos.	Ausführung Model Version Tipo	Bandbreite Tape width Largeur de bande Ancho de la cinta	Teile-Nr. Part No. N° de piezas N° de pieza
24			91-056 906-15
25			91-050 939-05
26			91-056 899-05
27			91-056 900-05
28			11-330 955-15
29			91-056 905-05
30			11-130 233-15
31 - 39			91-041 644-70/895
31			91-025 694-05
32			91-043 143-25
33 - 34			91-043 161-92
34			91-000 388-15
35			91-043 138-71/895
36			11-505 292-25
37			91-043 148-21
38			91-026 558-75/895
39			11-470 355-15
40 - 48			91-053 983-71/895
40			91-100 299-25
41			91-053 792-75/895
42			11-505 292-25
43			91-053 793-25
44			91-043 936-21
45			91-008 026-05
46 - 47			91-053 794-11
47			11-314 946-15

-725/04 A♦

Arbeitsgang
 Operation
 Opération
 Operación

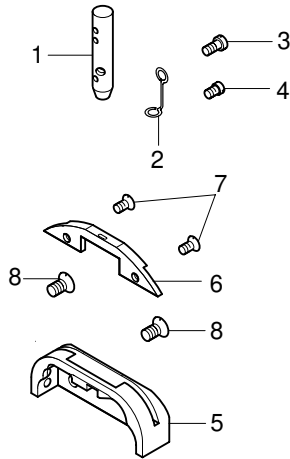
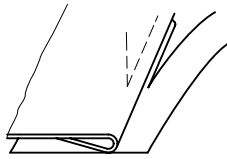

Pos.-Nr. Item No. N° pos.	Schneidabstand Trimming margin Distance de coupe Margen de corte	Teile-Nr. Part No. N° de piezas N° de pieza
1		91-175 097-05
2		91-175 098-05
3		11-108 093-15
4		91-173 664-15
5 - 7	1,0 1,2	91-150 266-93/001 91-150 266-93/002
5		91-150 189-05
6	1,0 1,1 1,2	91-150 267-04/001 91-150 267-04/002 91-150 267-04/003
7		11-210 038-15
8		91-100 296-25

-725/04-900/53 A♦

Arbeitsgang
 Operation
 Opération
 Operación

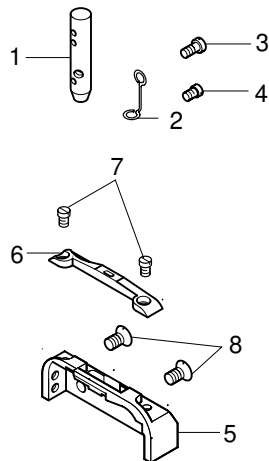
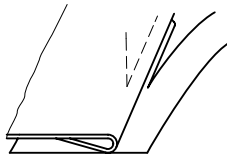

Pos.-Nr. Item No. N° pos.	Schneidabstand Trimming margin Distance de coupe Margen de corte	Teile-Nr. Part No. N° de piezas N° de pieza
1		91-175 097-05
2		91-175 098-05
3		11-108 093-15
4		91-173 664-15
5 - 7	1,0 0,8 2,5 1,2 1,5	91-150 605-93/001 91-150 605-93/002 91-150 605-93/003 91-150 605-93/004 91-150 605-93/005
5		91-150 603-05
6	0,8 0,9 1,0 1,1 1,2 1,5 1,6 2,0 2,5	91-150 265-04/001 91-150 265-04/002 91-150 265-04/003 91-150 265-04/004 91-150 265-04/005 91-150 265-04/006 91-150 265-04/007 91-150 265-04/008 91-150 265-04/009
7		11-174 086-15
8		91-100 296-25

-725/04 B♦

Arbeitsgang
Operation
Opération
Opéracion

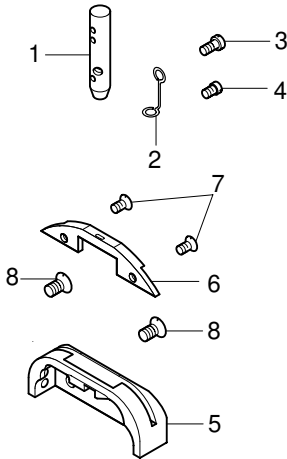
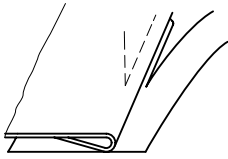

Pos.-Nr. Item No. N° pos. N° de pos.	Schneidabstand Trimming margin Distance de coupe Margen de corte	Teile-Nr. Part No. N° de piezas N° de pieza
1		91-175 097-05
2		91-175 098-05
3		11-108 093-15
4		91-173 664-15
5 - 7	1,2 2,5	91-150 337-93/001 91-150 337-93/002
5		91-150 189-05
6	1,2 1,3 1,4 1,5 1,6 1,8 2,0 2,5	91-150 338-04/001 91-150 338-04/002 91-150 338-04/003 91-150 338-04/004 91-150 338-04/005 91-150 338-04/006 91-150 338-04/007 91-150 338-04/008
7		11-210 038-15
8		91-100 296-25

-725/04-900/53 B♦

Arbeitsgang
Operation
Opération
Opéracion

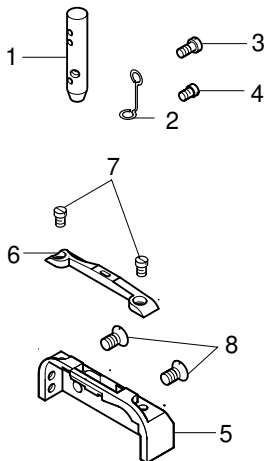
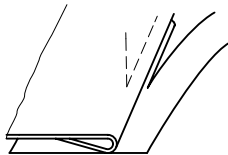

Pos.-Nr. Item No. N° pos. N° de pos.	Schneidabstand Trimming margin Distance de coupe Margen de corte	Teile-Nr. Part No. N° de piezas N° de pieza
1		91-175 097-05
2		91-175 098-05
3		11-108 093-15
4		91-173 664-15
5 - 7	1,2 2,5	91-150 606-93/001 91-150 606-93/002
5		91-150 603-05
6	1,2 1,3 1,5 1,6 1,8 2,0 2,5	91-150 336-04/001 91-150 336-04/002 91-150 336-04/003 91-150 336-04/004 91-150 336-04/005 91-150 336-04/006 91-150 336-04/007
7		11-174 086-15
8		91-100 296-25

Zum Herstellen von Zier- und Befestigungsnähten an feinen Materialien.
(Ausführung AN36*)

For sewing fancy seams and assembly seams on lightweight materials.
(Model AN36*)

Pour les coutures d'ornementation et de fixation sur matières fines.
(version AN36*)

Para ejecutar costuras de adorno y de fijación de materiales ligeros.
(Tipo AN36*)

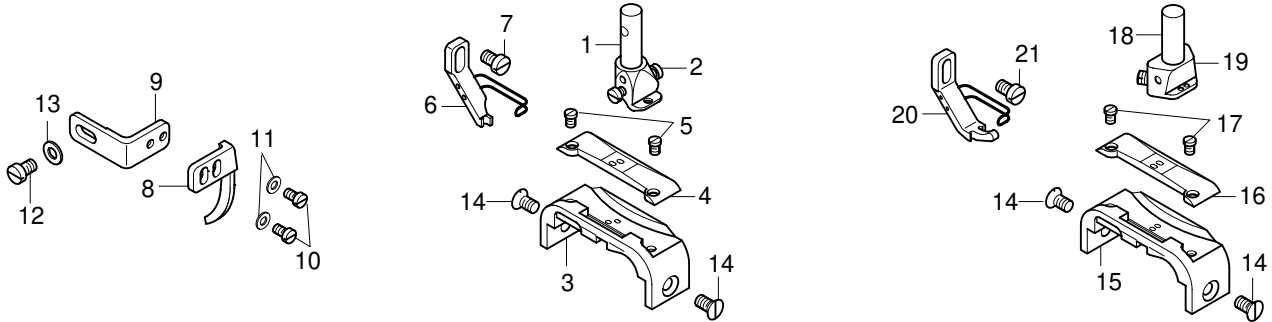

Pos.-Nr. Item No. N° pos.	Nadelabstand Needle gauge Ecartement des aiguilles Distancia entre agujas	Nadelabstand Diagonal needle distance Ecartement diagonal des aiguilles Distancia diagonal entre agujas	Teil-Nr. Part No. N° de pieza
1 - 2	0,8 - 2,2	2,4	91-118 195-93/001
2			91-700 868-15
3 - 5	1,2 1,6 1,8 2,0 2,2	2,4	91-150 637-93/003 91-150 637-93/004 91-150 637-93/005 91-150 637-93/002 91-150 637-93/009
3	1,2 1,6 1,8 2,0 2,2	2,4	91-158 704-04/001 91-158 704-04/002 91-158 704-04/004 91-158 704-04/003 91-158 704-04/005
4	(1,0) x 0,8 1,0 1,2 (1,4) x 1,2 1,4 1,6 (1,4) x 1,6 1,8 2,0 2,2	2,4	91-150 621-04/002 91-150 621-04/003 91-150 621-04/010 91-150 621-04/004 91-150 621-04/001 91-150 621-04/011 91-150 621-04/005 91-150 621-04/006 91-150 621-04/008 91-150 621-04/009
5			91-165 344-15
6	0,8 1,0 1,2 1,4 1,6 1,8 2,0 2,2	2,4	91-049 654-03/001 91-049 654-03/002 91-049 654-03/003 91-049 654-03/004 91-049 654-03/005 91-049 660-03/001 91-049 660-03/002 91-049 660-03/003
7			11-108 171-15
8 - 11	0,8 1,0 1,2 1,4 1,6	2,4	91-175 026-13/001 91-175 026-13/002 91-175 026-13/003 91-175 026-13/004 91-175 026-13/005
8	0,8 1,0 1,2	2,4	91-049 650-14/001 91-049 650-14/002 91-049 650-14/004

Pos.-Nr. Item No. N° pos.	Nadelabstand Needle gauge Ecartement des aiguilles Distancia entre agujas	Nadelabstand Diagonal needle distance Ecartement diagonal des aiguilles Distancia diagonal entre agujas	Teil-Nr. Part No. N° de pieza
	1,4 1,6	2,4 2,4	91-049 650-14/005 91-049 650-14/003
9			91-175 027-15
10			11-108 090-15
11			12-315 080-15
12			11-108 171-15
13			12-305 114-15
14			91-100 296-25
15 - 17	2,4 3,2 3,6 4,0 4,8		91-150 636-93/001 91-150 636-93/003 91-150 636-93/005 91-150 636-93/007 91-150 636-93/009
15	2,4 3,2 3,6 4,0 4,8		91-158 708-04/002 91-158 708-04/004 91-158 708-04/008 91-158 708-04/005 91-158 708-04/007
16	2,4 3,2 3,6 4,0 4,8		91-150 627-04/001 91-150 627-04/003 91-150 627-04/005 91-150 627-04/007 91-150 627-04/008
17			91-165 344-15
18 - 19	2,4 2,8 3,2 3,6 4,0 4,8		91-119 309-93/001 91-119 309-93/002 91-119 309-93/003 91-119 309-93/004 91-119 309-93/005 91-119 309-93/006
19			11-330 082-15
20	2,4 2,8 3,2 3,6 4,0 4,8		91-049 664-03/001 91-049 664-03/002 91-049 664-03/003 91-049 664-03/004 91-049 664-03/005 91-049 664-03/006
21			11-108 171-15

Zum Herstellen von Zier- und Befestigungsnähten an feinen Materialien.
(Ausführung -900/53 AN36*)

For sewing fancy seams and assembly seams on lightweight materials.
(Model -900/53 AN36*)

Pour les coutures d'ornementation et de fixation sur matières fines.
(version -900/53 AN36*)

Para ejecutar costuras de adorno y de fijación de materiales ligeros.
(Tipo -900/53 AN36*)

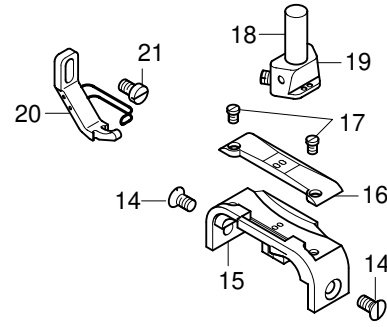
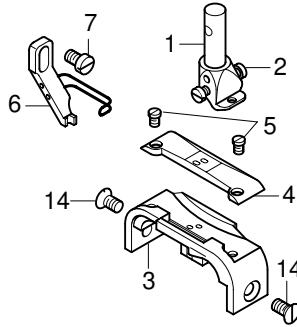
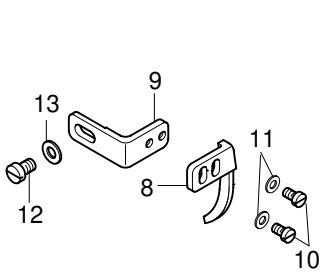

Pos.-Nr. Item No. N° pos. N° de pos.	Nadelabstand Needle gauge Ecartement des aiguilles Distancia entre agujas	Nadelabstand Diagonal needle distance Ecartement diagonal des aiguilles Distancia diagonal entre agujas	Teil-Nr. Part No. N° de piezas N° de pieza
1 - 2	0,8 - 2,2	2,4	91-118 195-93/001
2			91-700 868-15
3 - 5	1,2 1,4 1,6 1,8 2,0 2,2	2,4	91-150 622-93/010 91-150 622-93/013 91-150 622-93/011 91-150 622-93/005 91-150 622-93/007 91-150 622-93/009
3	1,2 1,4 1,6 1,8 2,0 2,2	2,4	91-150 630-04/001 91-150 630-04/002 91-150 630-04/003 91-150 630-04/004 91-150 630-04/005 91-150 630-04/006
4	(1,0) x 0,8 1,0 1,2 (1,4) x 1,2 1,4 1,6 (1,4) x 1,6 1,8 2,0 2,2	2,4	91-150 621-04/002 91-150 621-04/003 91-150 621-04/010 91-150 621-04/004 91-150 621-04/001 91-150 621-04/011 91-150 621-04/005 91-150 621-04/006 91-150 621-04/008 91-150 621-04/009
5			91-165 344-15
6	0,8 1,0 1,2 1,4 1,6 1,8 2,0 2,2	2,4	91-049 654-03/001 91-049 654-03/002 91-049 654-03/003 91-049 654-03/004 91-049 654-03/005 91-049 660-03/001 91-049 660-03/002 91-049 660-03/003
7			11-108 171-15
8 - 11	0,8 1,0 1,2 1,4 1,6	2,4	91-175 026-13/001 91-175 026-13/002 91-175 026-13/003 91-175 026-13/004 91-175 026-13/005
8	0,8 1,0	2,4	91-049 650-14/001 91-049 650-14/002

Pos.-Nr. Item No. N° pos. N° de pos.	Nadelabstand Needle gauge Ecartement des aiguilles Distancia entre agujas	Nadelabstand Diagonal needle distance Ecartement diagonal des aiguilles Distancia diagonal entre agujas	Teil-Nr. Part No. N° de piezas N° de pieza
	1,2 1,4 1,6	2,4	91-049 650-14/004 91-049 650-14/005 91-049 650-14/003
9			91-175 027-15
10			11-108 090-15
11			12-315 080-15
12			11-108 171-15
13			12-305 114-15
14			91-100 296-25
15 - 17	2,4 3,2 3,6 4,0 4,8		91-150 628-93/001 91-150 628-93/003 91-150 628-93/005 91-150 628-93/007 91-150 628-93/009
15	2,4 3,2 3,6 4,0 4,8		91-150 629-04/001 91-150 629-04/003 91-150 629-04/004 91-150 629-04/005 91-150 629-04/006
16	2,4 3,2 3,6 4,0 4,8		91-150 627-04/001 91-150 627-04/003 91-150 627-04/005 91-150 627-04/007 91-150 627-04/008
17			91-165 344-15
18 - 19	2,4 2,8 3,2 3,6 4,0 4,8		91-119 309-93/001 91-119 309-93/002 91-119 309-93/003 91-119 309-93/004 91-119 309-93/005 91-119 309-93/006
19			11-330 082-15
20	2,4 2,8 3,2 3,6 4,0 4,8		91-049 664-03/001 91-049 664-03/002 91-049 664-03/003 91-049 664-03/004 91-049 664-03/005 91-049 664-03/006
21			11-108 171-15

Zum Herstellen von Zier- und Befestigungsnähten an mittleren bis mittelschweren Materialien.
(Ausführung B/CN36[♦])

For sewing fancy seams and assembly seams on medium to medium heavyweight materials.
(Model B/CN36[♦])

Pour les coutures d'ornementation et de fixation sur matières moyennes à mi-lourdes.
(version B/CN36[♦])

Para ejecutar costuras de adorno y de fijación de materiales medianos a semipesados.
(Tipo B/CN36[♦])

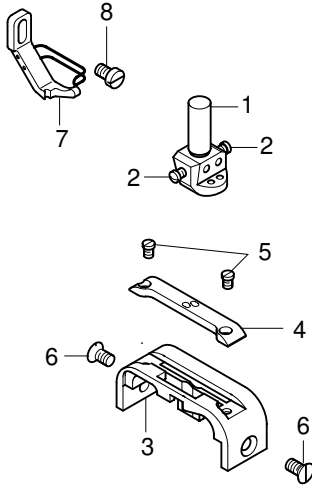

Pos.-Nr. Item No. N° pos.	Nadelabstand Needle gauge Ecartement des aiguilles Distancia entre agujas	Nadelabstand Diagonal needle distance Ecartement diagonal des aiguilles Distancia diagonal entre agujas	Teile-Nr. Part No. N° de piezas N° de pieza
1 - 2	2,2;2,4	2,8	91-164 726-92
2			91-165 344-15
3 - 5			91-150 634-91
3			91-150 584-05
4			91-150 635-05
5			91-165 344-15
6			91-100 296-25
7			91-149 192-01
8			11-108 171-15

Zum Herstellen von Zier- und Befestigungsnähten an mittleren bis mittelschweren Materialien.
(Ausführung -900/53 B/CN36[♦])

For sewing fancy seams and assembly seams on medium to medium heavyweight materials.
(Model -900/53 B/CN36[♦])

Pour les coutures d'ornementation et de fixation sur matières moyennes à mi-lourdes.
(version -900/53 B/CN36[♦])

Para ejecutar costuras de adorno y de fijación de materiales medianos a semipesados.
(Tipo -900/53 B/CN36[♦])

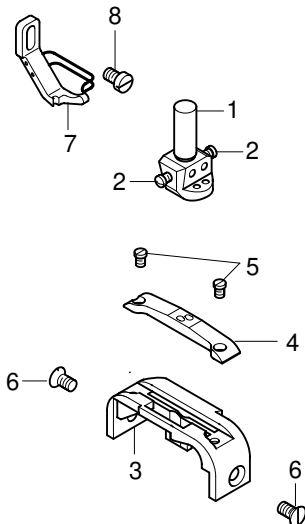

Pos.-Nr. Item No. N° pos.	Nadelabstand Needle gauge Ecartement des aiguilles Distancia entre agujas	Nadelabstand Diagonal needle distance Ecartement diagonal des aiguilles Distancia diagonal entre agujas	Teile-Nr. Part No. N° de piezas N° de pieza
1 - 2	2,2;2,4	2,8	91-164 726-92
2			91-165 344-15
3 - 5			91-150 609-91
3			91-150 611-05
4			91-150 610-05
5			91-165 344-15
6			91-100 296-25
7			91-149 192-01
8			11-108 171-15

Zum Herstellen von Zier- und Befestigungsnähten an mittleren Materialien.
(Ausführung BN36*)

For sewing fancy seams and assembly seams on medium-weight materials.
(Model BN36*)

Pour les coutures d'ornementation et de fixation sur matières moyennes.
(version BN36*)

Para ejecutar costuras de adorno y de fijación de materiales medianos.
(Tipo BN36*)

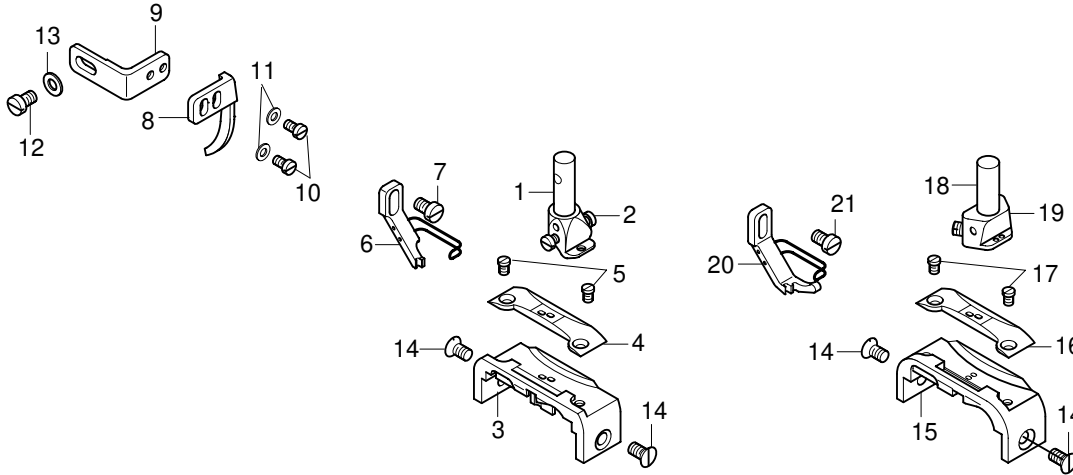

Pos.-Nr. Item No. N° pos.	Nadelabstand Needle gauge Ecartement des aiguilles Distancia entre agujas	Nadelabstand Needle gauge Ecartement des aiguilles Distancia entre agujas	Teile-Nr. Part No. N° de piezas
1 - 2	1,2; 1,4; 1,6		91-118 195-93/002
	1,8; 2,0; 2,2; 2,4; 2,8		91-118 195-93/003
2			91-700 868-15
3 - 5	1,2	3,2	91-150 638-93/001
	1,4	3,2	91-150 638-93/007
	1,6	3,2	91-150 638-93/009
	1,8	3,2	91-150 638-93/011
	2,0	3,2	91-150 638-93/013
	2,2	3,2	91-150 638-93/015
	2,4	3,2	91-150 638-93/002
3	2,8	3,2	91-150 638-93/017
	1,2	3,2	91-158 706-04/001
	1,4	3,2	91-158 706-04/008
	1,6	3,2	91-158 706-04/002
	1,8	3,2	91-158 706-04/003
	2,0	3,2	91-158 706-04/004
	2,2	3,2	91-158 706-04/005
4	2,4	3,2	91-158 706-04/006
	2,8	3,2	91-158 706-04/007
	1,2	3,2	91-150 625-04/009
4	1,4	3,2	91-150 625-04/004
	1,6	3,2	91-150 625-04/010

Pos.-Nr. Item No. N° pos.	Nadelabstand Needle gauge Ecartement des aiguilles Distancia entre agujas	Nadelabstand Needle gauge Ecartement des aiguilles Distancia entre agujas	Teile-Nr. Part No. N° de piezas
5	1,8	3,2	91-150 625-04/005
	2,0	3,2	91-150 625-04/006
	2,2	3,2	91-150 625-04/007
	2,4	3,2	91-150 625-04/003
	2,8	3,2	91-150 625-04/008
5			91-165 344-15
6	1,2	3,2	91-049 657-03/003
	1,4	3,2	91-049 657-03/004
	1,6	3,2	91-049 657-03/005
	1,8	3,2	91-049 662-03/001
	2,0	3,2	91-049 662-03/002
	2,2	3,2	91-049 662-03/003
	2,4	3,2	91-049 662-03/004
	2,8	3,2	91-049 662-03/005
7			11-108 171-15
8 - 11	1,2	3,2	91-175 028-13/003
	1,4	3,2	91-175 028-13/004
	1,6	3,2	91-175 028-13/005
8	1,2	3,2	91-049 653-14/008
	1,4	3,2	91-049 653-14/009
	1,6	3,2	91-049 653-14/010

Zum Herstellen von Zier- und Befestigungsnähten an mittleren Materialien.
(Ausführung BN36*)

For sewing fancy seams and assembly seams on medium-weight materials.
(Model BN36*)

Pour les coutures d'ornementation et de fixation sur matières moyennes.
(version BN36*)

Para ejecutar costuras de adorno y de fijación de materiales medianos.
(Tipo BN36*)

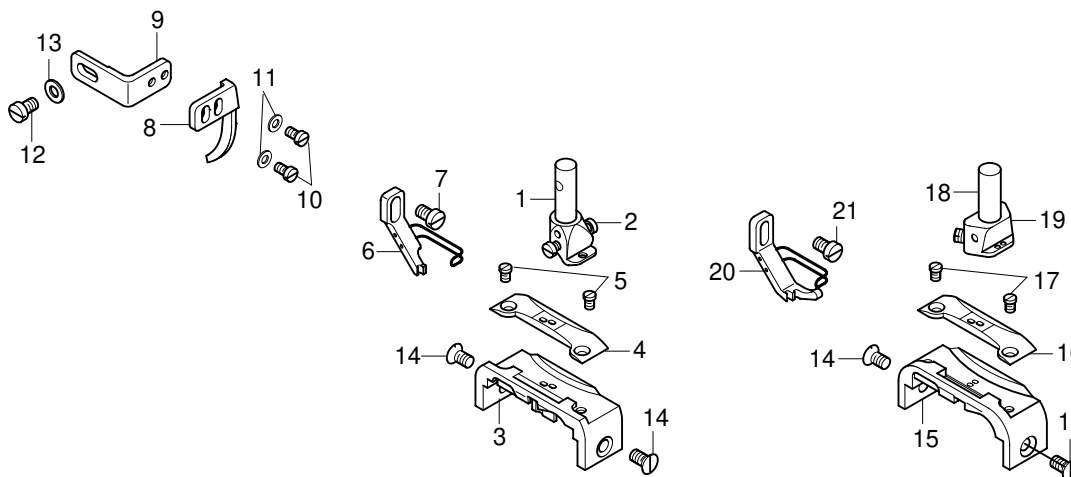

Pos.-Nr. Item No. N° pos.	Nadelabstand Needle gauge Ecartement des aiguilles Distancia entre agujas	Nadeldiagonalabstand Diagonal needle distance Ecartement diagonal des aiguilles Distancia diagonal entre agujas	Teile-Nr. Part No. N° de piezas
9			91-175 027-15
10			11-108 090-15
11			12-315 080-15
12			11-108 171-15
13			12-305 114-15
14			91-100 296-25
15 - 17	2,4 2,8 3,2 3,6 4,0 4,8		91-150 636-93/002 91-150 636-93/012 91-150 636-93/004 91-150 636-93/006 91-150 636-93/011 91-150 636-93/010
15	2,4 2,8 3,2 3,6 4,0 4,8		91-158 708-04/002 91-158 708-04/006 91-158 708-04/004 91-158 708-04/008 91-158 708-04/005 91-158 708-04/007
16	2,4 2,8 3,2 3,6 4,0 4,8		91-150 627-04/002 91-150 627-04/011 91-150 627-04/004 91-150 627-04/006 91-150 627-04/010 91-150 627-04/009
17			91-165 344-15
18 - 19	2,4 2,8 3,2 3,6 4,0 4,8		91-119 309-93/001 91-119 309-93/002 91-119 309-93/003 91-119 309-93/004 91-119 309-93/005 91-119 309-93/006
19			11-330 082-15
20	2,4 2,8 3,2 3,6 4,0 4,8		91-049 664-03/001 91-049 664-03/002 91-049 664-03/003 91-049 664-03/004 91-049 664-03/005 91-049 664-03/006
21			11-108 171-15

Zum Herstellen von Zier- und Befestigungsnähten an mittleren Materialien.
(Ausführung -900/53 BN36*)

For sewing fancy seams and assembly seams on medium-weight materials.
(Model -900/53 BN36*)

Pour les coutures d'ornementation et de fixation sur matières moyennes.
(version -900/53 BN36*)

Para ejecutar costuras de adorno y de fijación de materiales medianos.
(Tipo -900/53 BN36*)

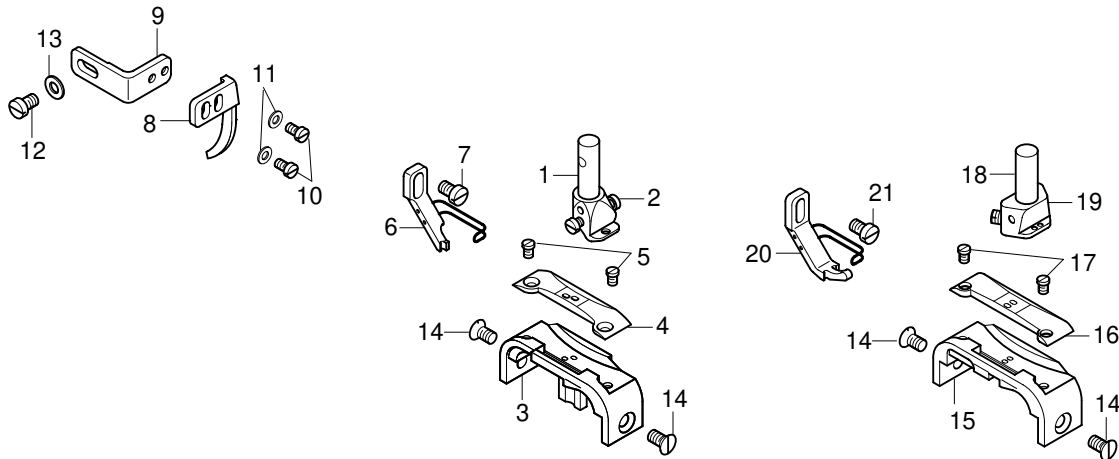

Pos.-Nr. Item No. N° de pos.	Nadelabstand Needle gauge Ecartement des aiguilles Distancia entre agujas	Nadel diagonalabstand Diagonal needle distance Ecartement diagonal des aiguilles Distancia diagonal entre agujas	Teile-Nr. Part No. N° de piezas N° de pieza
1 - 2	1,2; 1,4; 1,6		91-118 195-93/002
	1,8; 2,0; 2,2; 2,4; 2,8		91-118 195-93/003
2			91-700 868-15
3 - 5	1,2	3,2	91-150 626-93/001
	1,4	3,2	91-150 626-93/002
	1,6	3,2	91-150 626-93/003
	1,8	3,2	91-150 626-93/004
	2,0	3,2	91-150 626-93/005
	2,2	3,2	91-150 626-93/006
	2,4	3,2	91-150 626-93/007
	2,8	3,2	91-150 626-93/008
3	1,2	3,2	91-150 623-04/003
	1,4	3,2	91-150 623-04/005
	1,6	3,2	91-150 623-04/001
	1,8	3,2	91-150 623-04/004
	2,0	3,2	91-150 623-04/006
	2,2	3,2	91-150 623-04/007
	2,4	3,2	91-150 623-04/002
	2,8	3,2	91-150 623-04/008
4	1,2	3,2	91-150 625-04/009
	1,4	3,2	91-150 625-04/004
	1,6	3,2	91-150 625-04/010

Pos.-Nr. Item No. N° de pos.	Nadelabstand Needle gauge Ecartement des aiguilles Distancia entre agujas	Nadel diagonalabstand Diagonal needle distance Ecartement diagonal des aiguilles Distancia diagonal entre agujas	Teile-Nr. Part No. N° de piezas N° de pieza
1,8 2,0 2,2 2,4 2,8	1,8	3,2	91-150 625-04/005
	2,0	3,2	91-150 625-04/006
	2,2	3,2	91-150 625-04/007
	2,4	3,2	91-150 625-04/003
	2,8	3,2	91-150 625-04/008
5			91-165 344-15
6	1,2	3,2	91-049 657-03/003
	1,4	3,2	91-049 657-03/004
	1,6	3,2	91-049 657-03/005
	1,8	3,2	91-049 662-03/001
	2,0	3,2	91-049 662-03/002
	2,2	3,2	91-049 662-03/003
	2,4	3,2	91-049 662-03/004
	2,8	3,2	91-049 662-03/005
7			11-108 171-15
8 - 11	1,2	3,2	91-175 028-13/003
	1,4	3,2	91-175 028-13/004
	1,6	3,2	91-175 028-13/005
8	1,2	3,2	91-049 653-14/008
	1,4	3,2	91-049 653-14/009
	1,6	3,2	91-049 653-14/010

Zum Herstellen von Zier- und Befestigungsnähten an mittleren Materialien.
(Ausführung -900/53 BN36*)

For sewing fancy seams and assembly seams on medium-weight materials.
(Model -900/53 BN36*)

Pour les coutures d'ornementation et de fixation sur matières moyennes.
(version -900/53 BN36*)

Para ejecutar costuras de adorno y de fijación de materiales medianos.
(Tipo -900/53 BN36*)

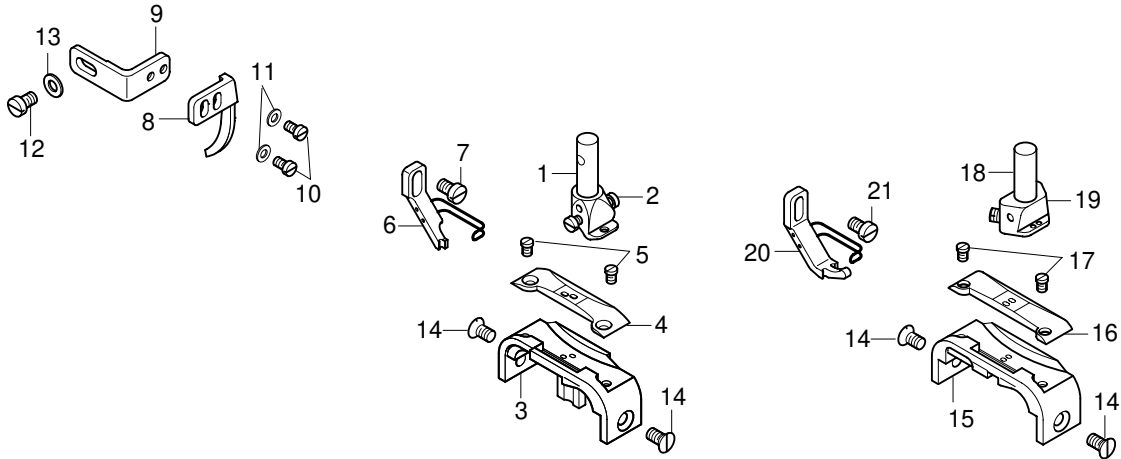

Pos.-Nr. Item No. N° pos. N° de pos.	Nadelabstand Needle gauge Ecartement des aiguilles Distancia entre agujas	Nadel diagonalabstand Diagonal needle distance Ecartement diagonal des aiguilles Distancia diagonal entre agujas	Teile-Nr. Part No. N° de piezas N° de pieza
9			91-175 027-15
10			11-108 090-15
11			12-315 080-15
12			11-108 171-15
13			12-305 114-15
14			91-100 296-25
15 - 17	2,4 2,8 3,2 3,6 4,0 4,8		91-150 628-93/002 91-150 628-93/011 91-150 628-93/004 91-150 628-93/006 91-150 628-93/008 91-150 628-93/010
15	2,4 2,8 3,2 3,6 4,0 4,8		91-150 629-04/001 91-150 629-04/002 91-150 629-04/003 91-150 629-04/004 91-150 629-04/005 91-150 629-04/006

Pos.-Nr. Item No. N° pos. N° de pos.	Nadelabstand Needle gauge Ecartement des aiguilles Distancia entre agujas	Nadel diagonalabstand Diagonal needle distance Ecartement diagonal des aiguilles Distancia diagonal entre agujas	Teile-Nr. Part No. N° de piezas N° de pieza
16	2,4 2,8 3,2 3,6 4,0 4,8		91-150 627-04/002 91-150 627-04/011 91-150 627-04/004 91-150 627-04/006 91-150 627-04/010 91-150 627-04/009
17			91-165 344-15
18 - 19	2,4 2,8 3,2 3,6 4,0 4,8		91-119 309-93/001 91-119 309-93/002 91-119 309-93/003 91-119 309-93/004 91-119 309-93/005 91-119 309-93/006
19			11-330 082-15
20	2,4 2,8 3,2 3,6 4,0 4,8		91-049 664-03/001 91-049 664-03/002 91-049 664-03/003 91-049 664-03/004 91-049 664-03/005 91-049 664-03/006
21			11-108 171-15

-725/04-900/53 BN36[◆]

Arbeitsgang
Operation
Opération
Operación

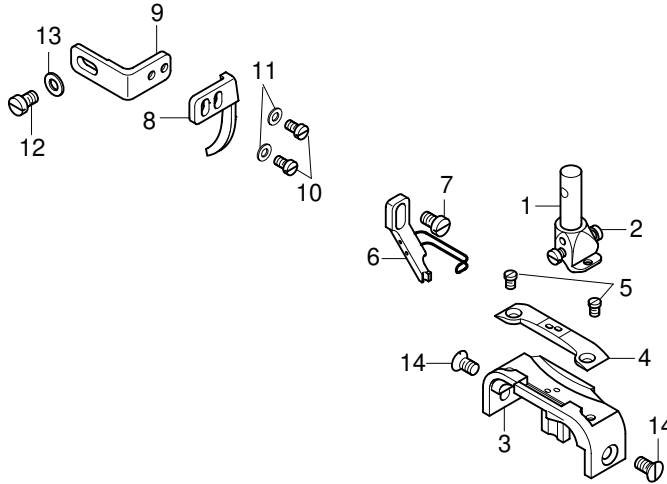
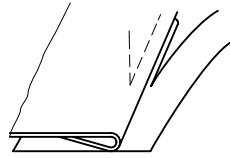

Pos.-Nr. Item No. N° pos. N° de pos.	Nadelabstand Needle gauge Ecartement des aiguilles Distancia entre agujas	Nadelabstand Diagonal needle distance Ecartement diagonal des aiguilles Distancia diagonal entre agujas	Schneidabstand Trimming margin Distance de coupe Margen de corte	Teile-Nr. Part No. N° de piezas N° de pieza
1 - 2	1,2;1,4;1,6			91-118 195-93/002
	1,8;2,0;2,2; 2,4;2,8			91-118 195-93/003
2				91-700 868-15
3 - 5	1,2 1,6 1,8 2,0 2,4	3,2 3,2 3,2 3,2 3,2	1,2 1,2 1,2 1,2 1,2	91-150 624-93/007 91-150 624-93/006 91-150 624-93/008 91-150 624-93/004 91-150 624-93/010
3	1,2 1,4 1,6 1,8 2,0 2,2 2,4 2,8	3,2 3,2 3,2 3,2 3,2 3,2 3,2 3,2		91-150 623-04/003 91-150 623-04/005 91-150 623-04/001 91-150 623-04/004 91-150 623-04/006 91-150 623-04/007 91-150 623-04/002 91-150 623-04/008
4	1,2 1,6 1,8 2,0 2,0 2,0 2,0 2,2 2,2 2,4 2,8	3,2 3,2 3,2 3,2 3,2 3,2 3,2 3,2 3,2 3,2 3,2	1,2 1,2 1,2 1,2 1,6 2,0 2,5 1,2 2,0 1,2 2,0	91-058 590-04/014 91-058 590-04/013 91-058 590-04/005 91-058 590-04/010 91-058 590-04/006 91-058 590-04/007 91-058 590-04/012 91-058 590-04/021 91-058 590-04/008 91-058 590-04/016 91-058 590-04/019

Pos.-Nr. Item No. N° pos. N° de pos.	Nadelabstand Needle gauge Ecartement des aiguilles Distancia entre agujas	Nadelabstand Diagonal needle distance Ecartement diagonal des aiguilles Distancia diagonal entre agujas	Schneidabstand Trimming margin Distance de coupe Margen de corte	Teile-Nr. Part No. N° de piezas N° de pieza
5				91-165 344-15
6	1,2 1,4 1,6 1,8 2,0 2,2 2,4 2,8	3,2 3,2 3,2 3,2 3,2 3,2 3,2 3,2		91-049 657-03/003 91-049 657-03/004 91-049 657-03/005 91-049 662-03/001 91-049 662-03/002 91-049 662-03/003 91-049 662-03/004 91-049 662-03/005
7				11-108 171-15
8 - 11	1,2 1,4 1,6	3,2 3,2 3,2		91-175 028-13/003 91-175 028-13/004 91-175 028-13/005
8	1,2 1,4 1,6	3,2 3,2 3,2		91-049 653-14/008 91-049 653-14/009 91-049 653-14/010
9				91-175 027-15
10				11-108 090-15
11				12-315 080-15
12				11-108 171-15
13				12-305-114-15
14				91-100 296-25

Zum Herstellen von Zier- und Befestigungsnähten an feinen Materialien.
 (Ausführung A*)

For sewing fancy seams and assembly seams on lightweight materials.
 (Model A*)

Pour les coutures d'ornementation et de fixation sur matières fines.
 (version A*)

Para ejecutar costuras de adorno y de fijación de materiales ligeros.
 (Tipo A*)

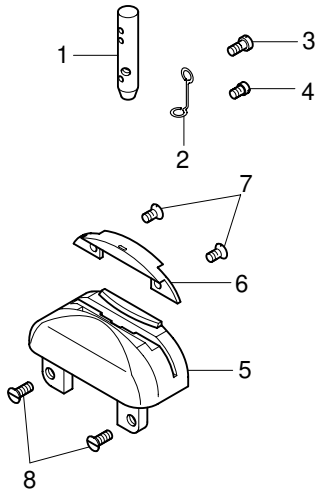

Pos.-Nr. Item No. N° pos. N° de pos.	Teile-Nr. Part No. N° de piezas N° de pieza
1	91-175 097-05
2	91-175 099-05
3	11-108 093-15
4	91-173 664-15
5 - 7	91-150 549-93/002
5	91-150 257-05
6	91-150 554-04/002
7	11-210 035-25
8	11-210 168-25

Zum Herstellen von Zier- und Befestigungsnähten an feinen Materialien.
 (Ausführung -900/53 A*)

For sewing fancy seams and assembly seams on lightweight materials.
 (Model -900/53 A*)

Pour les coutures d'ornementation et de fixation sur matières fines.
 (version -900/53 A*)

Para ejecutar costuras de adorno y de fijación de materiales ligeros.
 (Tipo -900/53 A*)

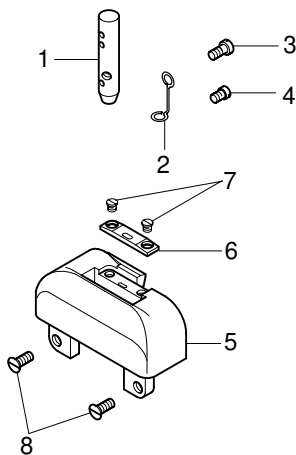

Pos.-Nr. Item No. N° pos. N° de pos.	Teile-Nr. Part No. N° de piezas N° de pieza
1	91-175 097-05
2	91-175 099-05
3	11-108 093-15
4	91-173 664-15
5 - 7	91-150 524-93/003
5	91-150 525-05
6	91-150 526-04/004
7	91-000 621-15
8	11-210 168-25

Zum Herstellen von Zier- und Befestigungsnähten an mittleren Materialien.
(Ausführung B*)

For sewing fancy seams and assembly seams on medium-weight materials.
(Model B*)

Pour les coutures d'ornementation et de fixation sur matières moyennes.
(version B*)

Para ejecutar costuras de adorno y de fijación de materiales medianos.
(Tipo B*)

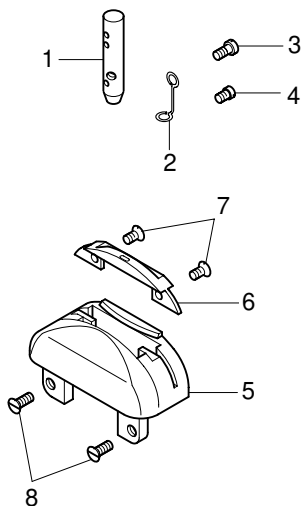

Pos.-Nr. Item No. N° pos. N° de pos.	Teil-Nr. Part No. N° de piezas N° de pieza
1	91-175 097-05
2	91-175 099-05
3	11-108 093-15
4	91-173 664-15
5 - 7	91-150 549-93/001
5	91-150 257-05
6	91-150 554-04/001
7	11-210 035-15
8	11-210 168-25

Zum Herstellen von Zier- und Befestigungsnähten an mittleren Materialien
(Ausführung -900/53 B*)

For sewing fancy seams and assembly seams on medium-weight materials.
(Model -900/53 B*)

Pour les coutures d'ornementation et de fixation sur matières moyennes.
(version -900/53 B*)

Para ejecutar costuras de adorno y de fijación de materiales medianos.
(Tipo -900/53 B*)

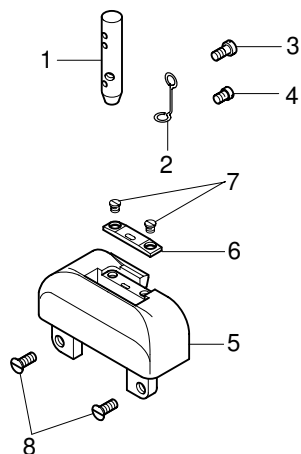

Pos.-Nr. Item No. N° pos. N° de pos.	Teil-Nr. Part No. N° de piezas N° de pieza
1	91-175 097-05
2	91-175 099-05
3	11-108 093-15
4	91-173 664-15
5 - 7	91-150 524-93/001
5	91-150 525-05
6	91-150 526-04/001
7	91-000 621-15
8	11-210 168-25

Zum Herstellen von Zier- und Befestigungsnähten an mittleren bis mittelschweren Materialien.
 (Ausführung B/CN7[♦])

For sewing fancy seams and assembly seams on medium-to medium heavyweight materials.
 (Model B/CN7[♦])

Pour les coutures d'ornementation et de fixation sur matières moyennes à mi-lourdes.
 (version B/CN7[♦])

Para ejecutar costuras de adorno y de fijación de materiales medianos a semipesados.
 (Tipo B/CN7[♦])

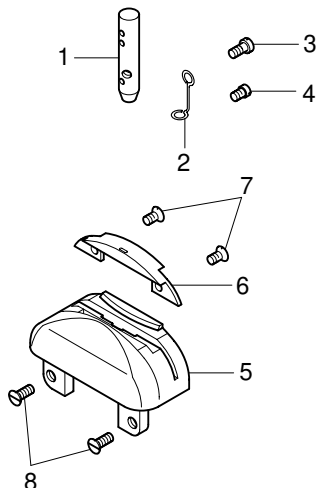

Pos.-Nr. Item No. N° pos. N° de pos.	Teil-Nr. Part No. N° de piezas N° de pieza
1	91-175 097-05
2	91-175 099-05
3	11-108 093-15
4	91-173 664-15
5 - 7	91-150 552-93/001
5	91-150 455-05
6	91-150 554-04/009
7	11-210 035-15
8	11-210 168-25

Zum Herstellen von Zier- und Befestigungsnähten an mittleren bis mittelschweren Materialien.
 (Ausführung -900/53 B/CN7[♦])

For sewing fancy seams and assembly seams on medium-to medium heavyweight materials.
 (Model -900/53 B/CN7[♦])

Pour les coutures d'ornementation et de fixation sur matières moyennes à mi-lourdes.
 (version -900/53 B/CN7[♦])

Para ejecutar costuras de adorno y de fijación de materiales medianos a semipesados.
 (Tipo -900/53 B/CN7[♦])

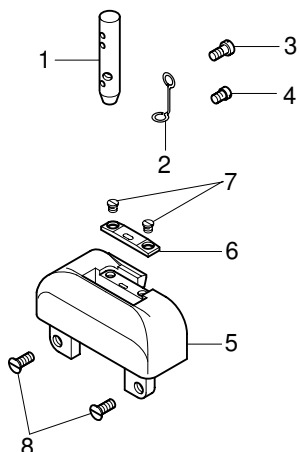

Pos.-Nr. Item No. N° pos. N° de pos.	Teil-Nr. Part No. N° de piezas N° de pieza
1	91-175 097-05
2	91-175 099-05
3	11-108 093-15
4	91-173 664-15
5 - 7	91-150 532-93/002
5	91-150 533-05
6	91-150 526-04/003
7	91-000 621-15
8	11-210 168-25

-725/04 A[◆]

Arbeitsgang
Operation
Opération
Opéracion

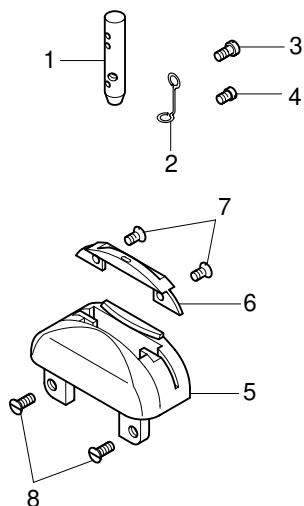
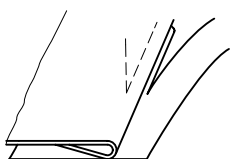

Pos.-Nr. Item No. N° pos. N° de pos.	Schneidabstand Trimming margin Distance de coupe Margen de corte	Teile-Nr. Part No. N° de pièces N° de pieza
1		91-175 097-05
2		91-175 099-05
3		11-108 093-15
4		91-173 664-15
5 - 7	0,8 0,9 1,0	91-158 644-93/001 91-158 644-93/002 91-158 644-93/003
5		91-158 645-05
6	0,8 0,9 1,0	91-158 646-04/001 91-158 646-04/002 91-158 646-04/003
7		11-210 035-15
8		11-210 168-25

-725/04-900/53 A[◆]

Arbeitsgang
Operation
Opération
Opéracion

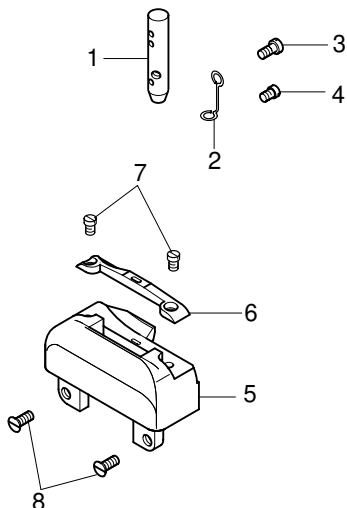
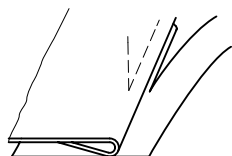

Pos.-Nr. Item No. N° pos. N° de pos.	Schneidabstand Trimming margin Distance de coupe Margen de corte	Teile-Nr. Part No. N° de pièces N° de pieza
1		91-175 097-05
2		91-175 099-05
3		11-108 093-15
4		91-173 664-15
5 - 7	1,0 0,8	91-150 249-93/001 91-150 249-93/002
5		91-150 250-05
6	1,0 1,2 1,5 0,8	91-150 251-04/001 91-150 251-04/002 91-150 251-04/003 91-150 251-04/004
7		11-174 086-15
8		11-210 168-25

-725/04 B♦

Arbeitsgang
 Operation
 Opération
 Operación

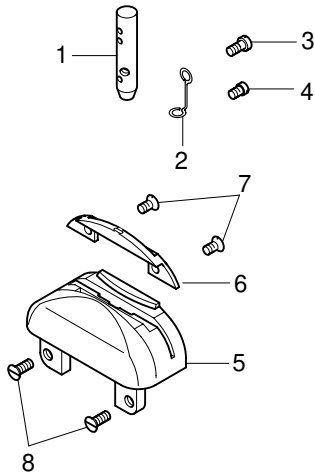
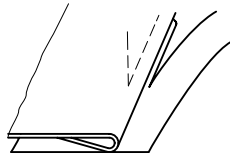

Pos.-Nr. Item No. N° pos. N° de pos.	Schneidabstand Trimming margin Distance de coupe Margen de corte	Teile-Nr. Part No. N° de piezas N° de pieza
1		91-175 097-05
2		91-175 099-05
3		11-108 093-15
4		91-173 664-15
5 - 7	1,2	91-150 377-93/001
5		91-150 200-05
6	1,2 1,3 1,4 1,5 1,8 2,0 2,5	91-150 378-04/001 91-150 378-04/002 91-150 378-04/003 91-150 378-04/004 91-150 378-04/005 91-150 378-04/006 91-150 378-04/007
7		11-210 035-15
8		11-210 168-25

-725/04-900/53 B♦

Arbeitsgang
 Operation
 Opération
 Operación

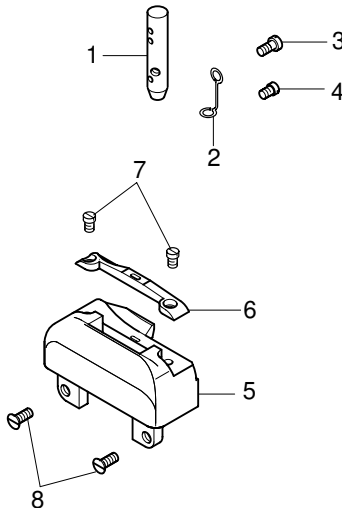
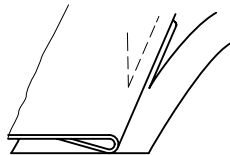

Pos.-Nr. Item No. N° pos. N° de pos.	Schneidabstand Trimming margin Distance de coupe Margen de corte	Teile-Nr. Part No. N° de piezas N° de pieza
1		91-175 097-05
2		91-175 099-05
3		11-108 093-15
4		91-173 664-15
5 - 7	1,2 2,5 2,0	91-150 242-93/001 91-150 242-93/002 91-150 242-93/003
5		91-150 243-05
6	1,2 1,3 1,5 1,6 2,5 2,0	91-150 244-04/001 91-150 244-04/002 91-150 244-04/003 91-150 244-04/004 91-150 244-04/006 91-150 244-04/007
7		11-174 086-15
8		11-210 168-25

-725/04 B/CN7♦

Arbeitsgang
Operation
Opération
Opéracion

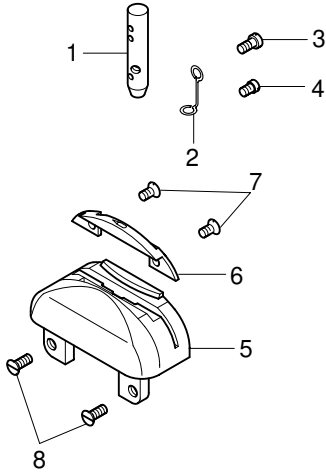
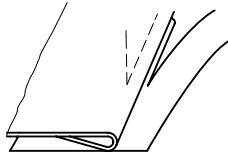

Pos.-Nr. Item No. N° pos. N° de pos.	Schneidabstand Trimming margin Distance de coupe Margen de corte	Teile-Nr. Part No. N° de piezas N° de pieza
1		91-175 097-05
2		91-175 099-05
3		11-108 093-15
4		91-173 664-15
5 - 7	1,5 2,0 2,5	91-058 584-93/001 91-058 584-93/002 91-058 584-93/004
5		91-150 455-05
6	1,5 1,6 1,8 2,0 2,5	91-058 585-04/001 91-058 585-04/002 91-058 585-04/003 91-058 585-04/004 91-058 585-04/005
7		11-210 035-15
8		11-210 168-25

-725/04-900/53 B/C♦

Arbeitsgang
Operation
Opération
Opéracion

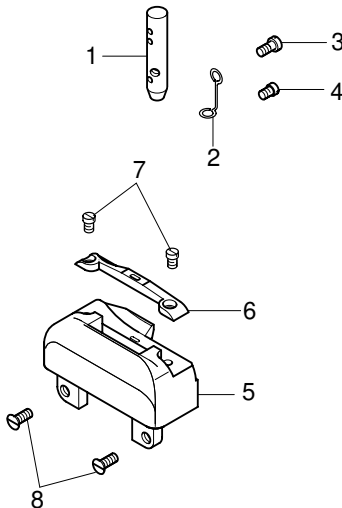
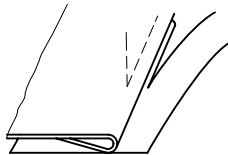

Pos.-Nr. Item No. N° pos. N° de pos.	Schneidabstand Trimming margin Distance de coupe Margen de corte	Teile-Nr. Part No. N° de piezas N° de pieza
1		91-175 097-05
2		91-175 099-05
3		11-108 093-15
4		91-173 664-15
5 - 7	1,5	91-150 245-93/001
5		91-158 264-05
6	1,5	91-150 246-04/001
7		11-174 086-15
8		11-210 168-25

-726/05 A[◆]

Arbeitsgang
 Operation
 Opération
 Operación

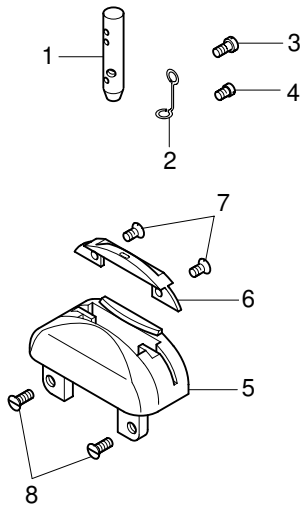
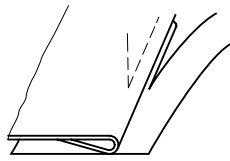

Pos.-Nr. Item No. N° pos. N° de pos.	Schneidabstand Trimming margin Distance de coupe Margen de corte	Teile-Nr. Part No. N° de pièces N° de piezas
1		91-175 097-05
2		91-175 099-05
3		11-108 093-15
4		91-173 664-15
5 - 7	0,8 0,9 1,0	91-158 644-93/001 91-158 644-93/002 91-158 644-93/003
5		91-158 645-05
6	0,8 0,9 1,0	91-158 646-04/001 91-158 646-04/002 91-158 646-04/003
7		11-210 035-15
8		11-210 168-25

-726/05-900/53 A[◆]

Arbeitsgang
 Operation
 Opération
 Operación

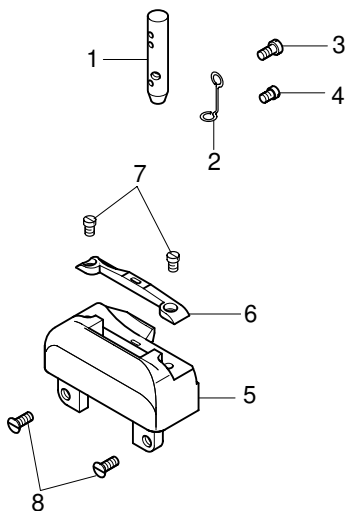
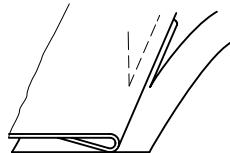

Pos.-Nr. Item No. N° pos. N° de pos.	Schneidabstand Trimming margin Distance de coupe Margen de corte	Teile-Nr. Part No. N° de pièces N° de piezas
1		91-175 097-05
2		91-175 099-05
3		11-108 093-15
4		91-173 664-15
5 - 7	1,0 0,8	91-150 249-93/001 91-150 249-93/002
5		91-150 250-05
6	1,0 1,2 1,5 0,8	91-150 251-04/001 91-150 251-04/002 91-150 251-04/003 91-150 251-04/004
7		11-174 086-15
8		11-210 168-25

-726/05 B♦

Arbeitsgang
Operation
Opération
Opéracion

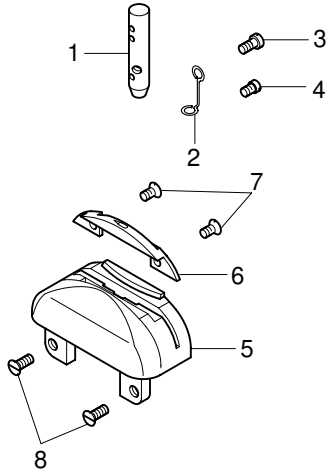
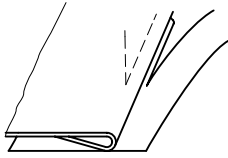

Pos.-Nr. Item No. N° pos. N° de pos.	Schneidabstand Trimming margin Distance de coupe Margen de corte	Teile-Nr. Part No. N° de piezas N° de pieza
1		91-175 097-05
2		91-175 099-05
3		11-108 093-15
4		91-173 664-15
5 - 7	1,2	91-150 377-93/001
5		91-150 200-05
6	1,2 1,3 1,4 1,5 1,8 2,0 2,5	91-150 378-04/001 91-150 378-04/002 91-150 378-04/003 91-150 378-04/004 91-150 378-04/005 91-150 378-04/006 91-150 378-04/007
7		11-210 035-15
8		11-210 168-25

-726/05-900/53 B♦

Arbeitsgang
Operation
Opération
Opéracion

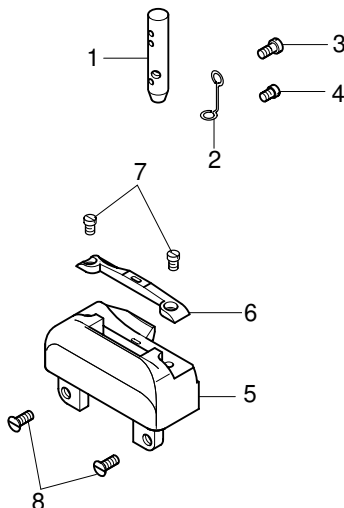
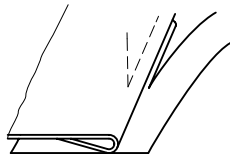

Pos.-Nr. Item No. N° pos. N° de pos.	Schneidabstand Trimming margin Distance de coupe Margen de corte	Teile-Nr. Part No. N° de piezas N° de pieza
1		91-175 097-05
2		91-175 099-05
3		11-108 093-15
4		91-173 664-15
5 - 7	1,2 2,5 2,0	91-150 242-93/001 91-150 242-93/002 91-150 242-93/003
5		91-150 243-05
6	1,2 1,3 1,5 1,6 2,5 2,0	91-150 244-04/001 91-150 244-04/002 91-150 244-04/003 91-150 244-04/004 91-150 244-04/006 91-150 244-04/007
7		11-174 086-15
8		11-210 168-25

-726/05 B/CN7♦

Arbeitsgang
 Operation
 Opération
 Opéracion

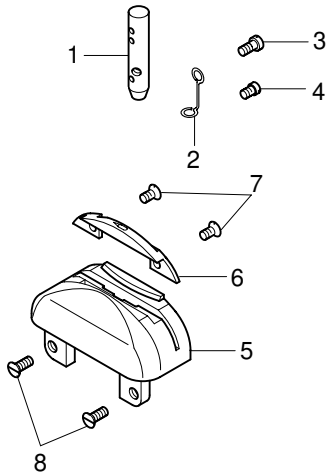
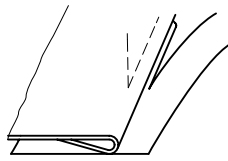

Pos.-Nr. Item No. N° pos. N° de pos.	Schneidabstand Trimming margin Distance de coupe Margen de corte	Teile-Nr. Part No. N° de piezas N° de pieza
1		91-175 097-05
2		91-175 099-05
3		11-108 093-15
4		91-173 664-15
5 - 7	1,5 2,0 2,5	91-058 584-93/001 91-058 584-93/002 91-058 584-93/004
5		91-150 455-05
6	1,5 1,6 1,8 2,0 2,5	91-058 585-04/001 91-058 585-04/002 91-058 585-04/003 91-058 585-04/004 91-058 585-04/005
7		11-210 035-15
8		11-210 168-25

-726/05-900/53 B/C♦

Arbeitsgang
 Operation
 Opération
 Opéracion

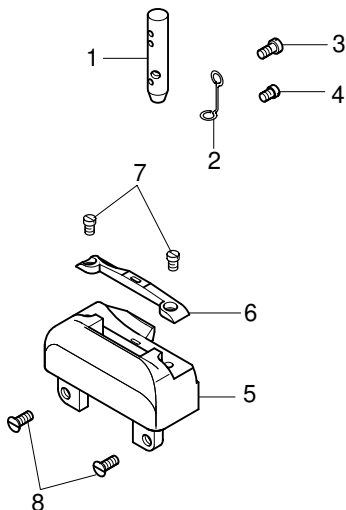
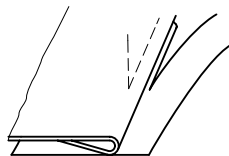

Pos.-Nr. Item No. N° pos. N° de pos.	Schneidabstand Trimming margin Distance de coupe Margen de corte	Teile-Nr. Part No. N° de piezas N° de pieza
1		91-175 097-05
2		91-175 099-05
3		11-108 093-15
4		91-173 664-15
5 - 7	1,5	91-150 245-93/001
5		91-158 264-05
6	1,5	91-150 246-04/001
7		11-174 086-15
8		11-210 168-25

PFAFF

G.M. PFAFF KAISERSLAUTERN
INDUSTRIEMASCHINEN AG

Postfach 3020
D-67653 Kaiserslautern

Königstr. 154
D-67655 Kaiserslautern

Telefon: (0631) 200-0
Telefax: (0631) 17202
E-Mail: info@pfaff-industrial.com

Gedruckt in der BRD
Printed in Germany
Imprimé en R.F.A.
Impreso en la R.F.A.