

PFAFF



543^{-712/01}_{-712/01}

Teileliste

Parts list

Liste de pièces

Lista de piezas



Die Inhaltsübersicht auf Seite 3 gibt einen Überblick über die Aufgliederung der Liste. Alle Teile sind so abgebildet, wie sie in der Maschine funktionsmäßig zusammengehören. Die gestrichelten Abbildungen zeigen, wo die daneben abgebildeten Teile hingehören. Einrahmungen auf den Bildseiten zeigen, aus welchen Einzelteilen sich die Gruppenteile zusammensetzen. Die auf den Bildseiten verwendeten Schlüsselzeichen ( ;  ;  usw.) sind in Register "0" erläutert.

Konstruktionsänderungen vorbehalten.



Achtung!

Wir machen ausdrücklich darauf aufmerksam, daß Ersatz- und Zubehörteile, die nicht von uns geliefert werden, auch nicht von uns geprüft und freigegeben sind. Der Einbau und / oder die Verwendung solcher Produkte kann daher u. Umständen konstruktiv vorgegebene Eigenschaften Ihrer Maschine negativ verändern. Für Schäden, die durch die Verwendung von Nicht-Originalteilen entstehen, übernehmen wir keine Haftung!



For the various sections of this catalogue, please refer to the "Contents" on page 3. The parts are illustrated as they belong together in the machine. The dashed illustrations show where the adjacent parts belong. The framed-in sections on the illustration pages show the individual parts comprising a group. The keys used on the illustration pages ( ;  ;  etc.) are listed and explained in section "0".

Subject to alterations in design.



Caution!

We warn you expressly that spare parts and accessories that are not supplied by us are not tested and released by us. Fitting or using these products may therefore have negative influences on features that depend on the machine design. We are not liable for any damage caused by the use of non-Pfaff parts.



La table des matières, page 3, donne un aperçu de la subdivision de la liste. Les pièces figurent sur l'illustration comme elles vont ensemble. Les figures en tirets montrent le lieu de montage des pièces figurant à côté. Les parties encadrées sur les pages à illustrations représentent les pièces individuelles formant groupe. Les symboles ( ;  ;  etc.) utilisés sur les pages illustrées sont regroupés et expliqués au registre "0".

Sous réserve de modifications.



Attention!

Nous attirons expressément votre attention sur le fait que les pièces de rechange et accessoires qui n'ont pas été livrés par nous n'ont pas non plus été contrôlés et agréés par nous. C'est pourquoi le montage et/ou l'utilisation de telles pièces peut éventuellement entraîner l'altération des caractéristiques de construction de votre machine. Par conséquent, nous n'assumons aucune responsabilité pour les dommages causés par l'emploi de pièces qui ne sont pas d'origine!

En la página 3, bajo el título "contenido", puede verse un resumen de la división de la "lista de piezas". Las piezas están ilustradas conforme se hallan montadas en la máquina. Las figuras a base de líneas entrecortadas muestran dónde y cómo van montadas las piezas ilustradas al lado. Los recuadros en las páginas ilustradas indican las piezas individuales de que se componen los grupos. Los símbolos clave ( ;  ;  etc.) utilizados en las páginas ilustradas se hallan recopilados y explicados en el registro "0".

Salvo modificaciones técnicas.



¡Atención!

Se hace observar que en el caso de piezas de recambio y accesorios que no hayan sido suministrados por nosotros, quiere decir que no han sido sometidas por nuestra parte a un control y que no se les ha dado el visto bueno. Por esta razón, el montaje y/o empleo de tales productos puede repercutir negativamente en las características constructivas previstas en su máquina. ¡Para los daños que eventualmente pudiesen presentarse al utilizar piezas no originales, no asumimos ninguna garantía!

Erläuterung der Schlüsselzeichen
Explanation of codes
Explication des codes
Explicaciones de los códigos

Kopf-, Arm-, Grundplatten- und Gehäuseteile
Needle head parts, arm-, base plate-, and housing parts
Pièce de tête, bras, plaque fondamentale et carcasse
Piezas de la cabeza, del brazo, de la placa base y de la carcasa

Fadenabschneid-Einrichtung
Thread trimmer -900/56
Coupe-fil
Cortahilos

Wartungseinheit
Air filter / lubricator -925/02
Conditionneur d'air comprimé
Grupo acondicionador del aire comprimido

Zubehörteile, Fadenöler, Einstellehren
Accessory parts, table of thread-lubricants, Adjustment gauges
Accessoires, tableau des lubrifiants, calibres
Accesorios, Tabla de lubricantes, Calibres de ajuste

Motoranschlußsatz, Positionsgeber
Motor connection kit, Synchronizer
Jeu de pièces à raccorder le moteur, synchronisateur
Juego de piezas de conexión del motor, Sincronizador

Keilriemenscheiben- und Schmiermitteltabelle
Table of pulleys and lubricants
Tableau des poulie pour courroie trapézoïdales et des lubrifiants
Tabla de poleas para correas trapezoidales y lubricantes

Index (Teilenummern / Seitenzahlen)
Index (part numbers / page numbers)
Index (numéros de pièces, de pages)
Index (números de pieza / números de página)

Nähwerkzeuge und Apparate
Gauge parts and attachments
Organes de couture et guides
Organos de costura y aparatos

- Unterklassenabhängig, Teilenummer siehe Nähwerkzeuge und Apparate.
Subclass-dependent, for part number see gauge parts and attachments.
Fonction de la sous-classe; pour le numéro de la pièce, voir "organes de couture et guides".
Dependientes de la subclase, para el número de pieza véase "órganos de costura y aparatos".
- 3 Geklebt
Part cemented
Pièce collée
Pieza pegada
- 4 Ausführungsart bei Bestellung angeben.
Model to be stated on order.
Préciser le modèle à la commande.
Indíquese el tipo en los pedidos.
- 6 Nadeldicke und Spitzenform bei Bestellung angeben.
Needle size and style of point to be stated on order.
Préciser la grosseur de l'aiguille et la forme de la pointe à la commande.
Grosor de aguja y forma de la punta, indíquese en los pedidos.
- 22 Zubehör
Accessories
Accessoires
Accesorios
- 35/1 Bei Montage vernieten.
To be riveted after assembly.
River après montage.
Remáchese después del montaje.
- 40/2 Tränken mit 280-1-120 144; Bestellnummer siehe Seite 32.
Soak with 280-1-120 144; for part number see page 32.
Imbiber d'huile 280-1-120 144; n° de commande, voir page 32.
Empape con aceite 280-1-120 144; para el número de pedido véase la página 32.
- 40/4 Fetten mit 280-1-120 243; Bestellnummer siehe Seite 32.
Grease with 280-1-120 243; for part number see page 32.
Graisser avec de la graisse 280-1-120 243; n° de commande, voir page 32.
Engrase con grasa 280-1-120 243 para el número de pedido véase la página 32.
- 90/1 Für Wechselstrom.
For single-phase A.C.
Pour du courant alternatif.
Para corriente alterna monofásica.
- 90/2 Für Drehstrom.
For three-phase A.C.
Pour du courant triphasé.
Para corriente trifásica.
- 90/3 Zur Motorbefestigung.
For fitting the motor.
Pour la fixation du moteur.
Para fijación del motor.
- 96 Länge angeben.
State length.
Préciser longueur.
Indíquese la largura.

Needle head parts
Pièces de tête
Piezas de la cabeza

PFAFF 543-712/..

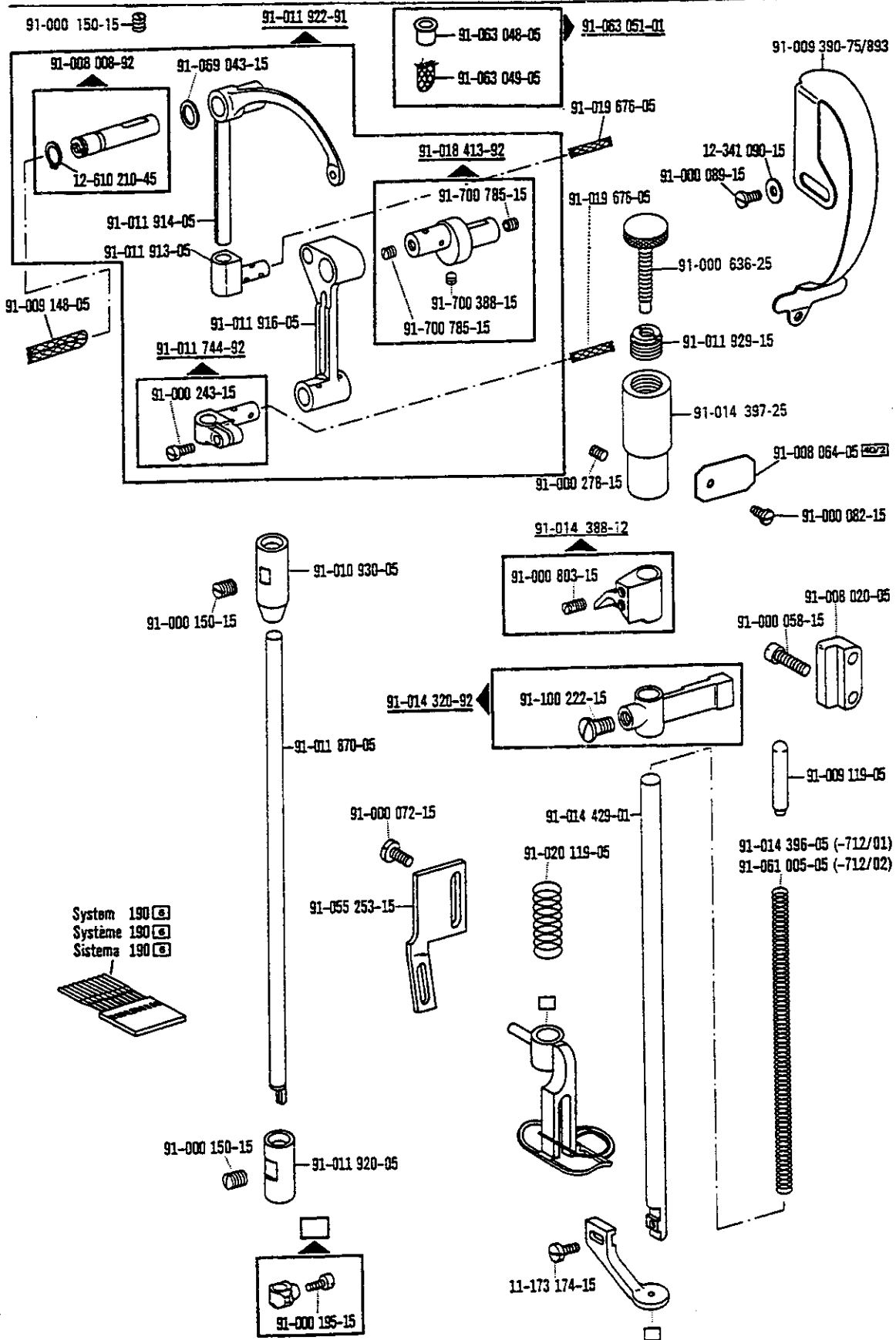

Basisteile
Basic parts
Pièces de base
Piezas básicas

☐ siehe Erläuterungen Register
see explanations in section
voir légende registre
ver explicaciones del registro

A 99

Basisteile
 Basic parts
 Pièces de base
 Piezas básicas

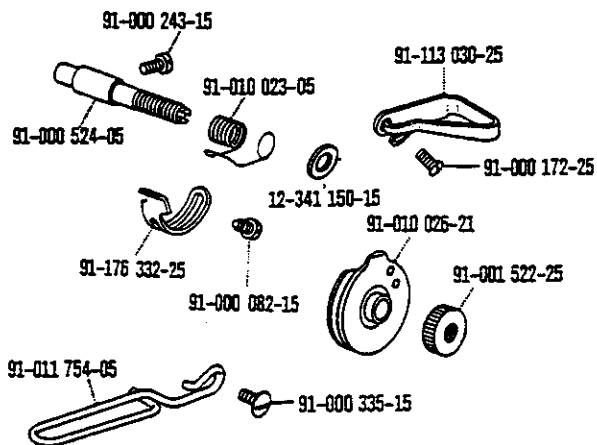
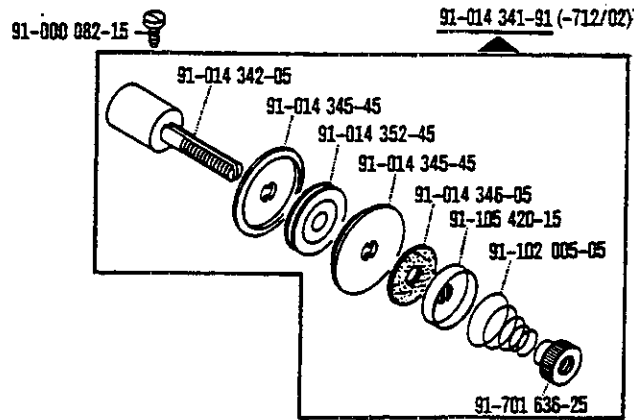
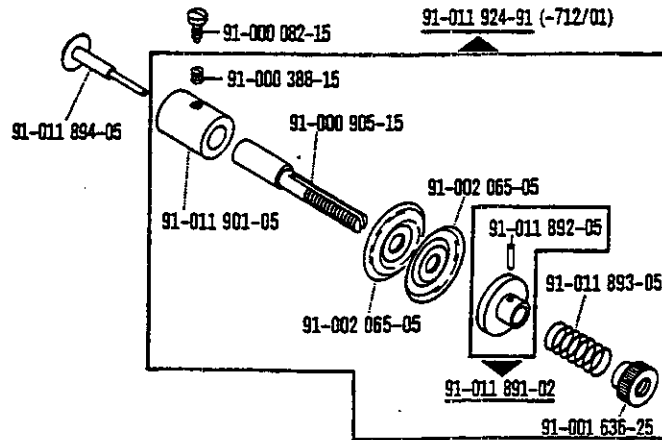

Basisteile
Basic parts
Pièces de base
Piezas básicas

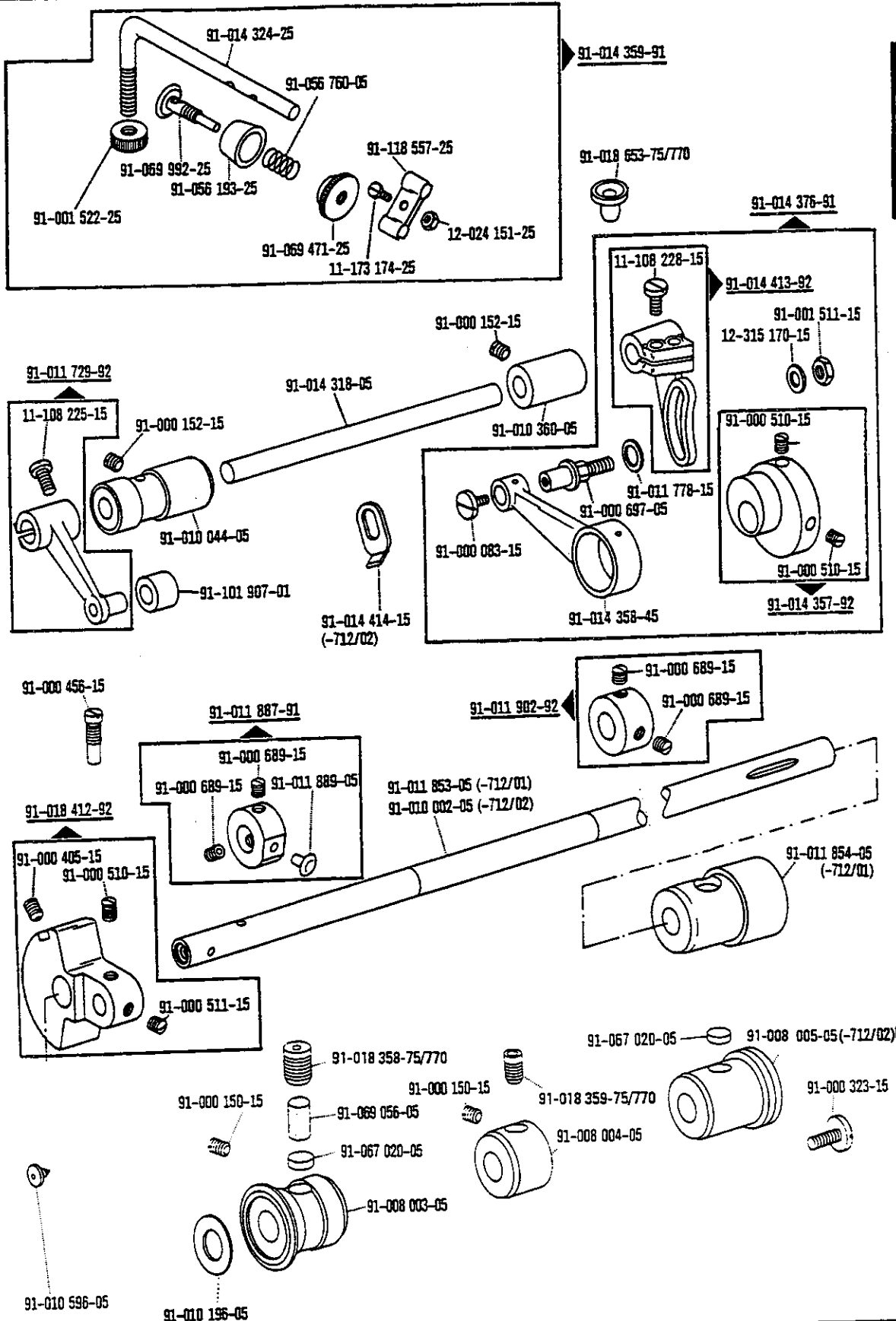

☐ siehe Erläuterungen Register
see explanations in section
voir légende registre
ver explicaciones del registro

Armteile
 Arm parts
 Pièces de bras
 Piezas del brazo

PFAFF 543-712/..

Basisteile
 Basic parts
 Pièces de base
 Piezas básicas

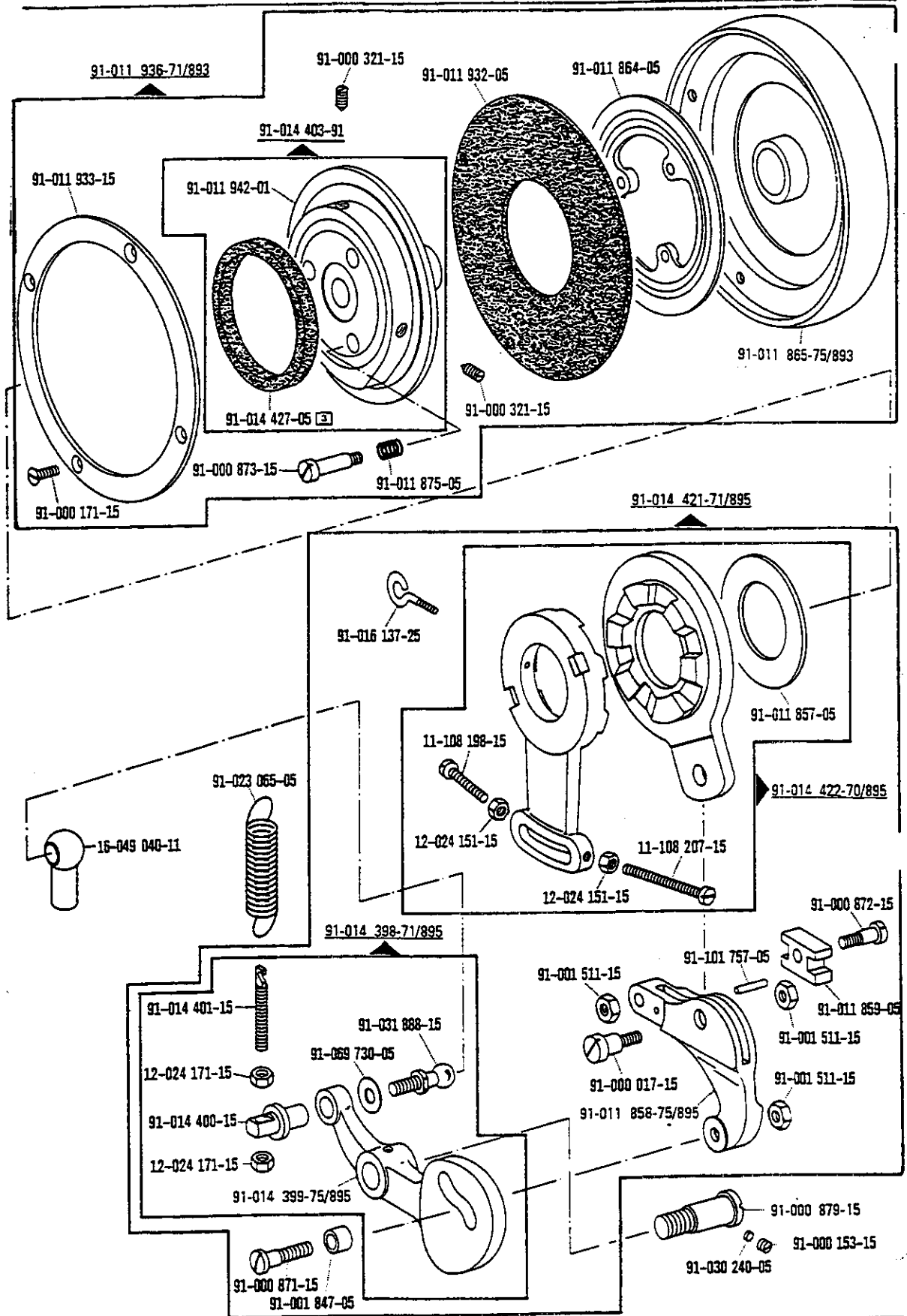

Basisteile
 Basic parts
 Pièces de base
 Piezas básicas

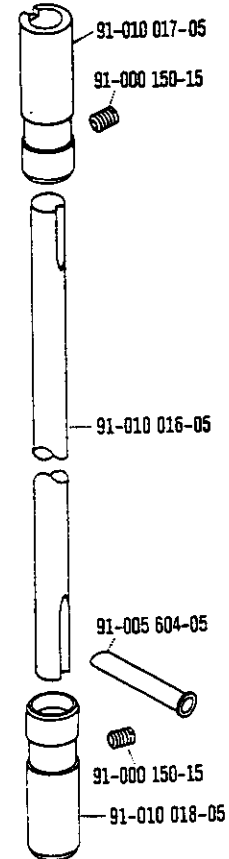
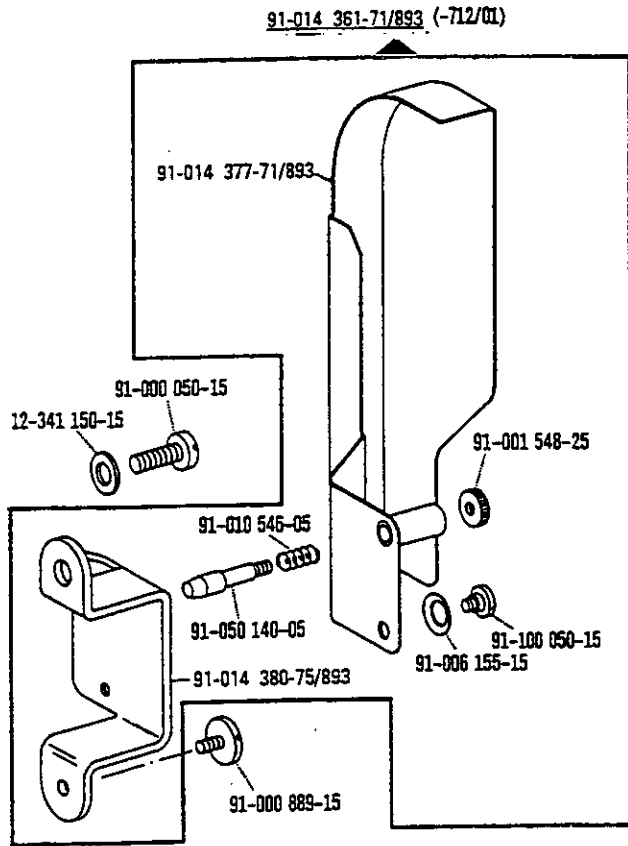
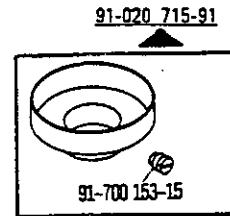
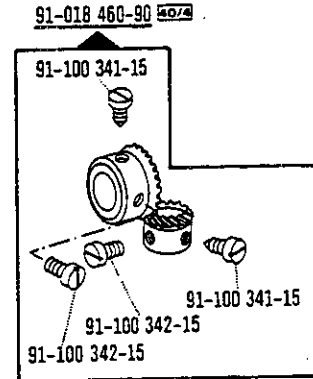
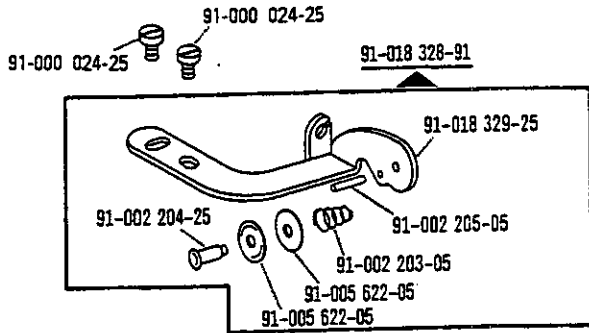

Basisteile
 Basic parts
 Pièces de base
 Piezas básicas

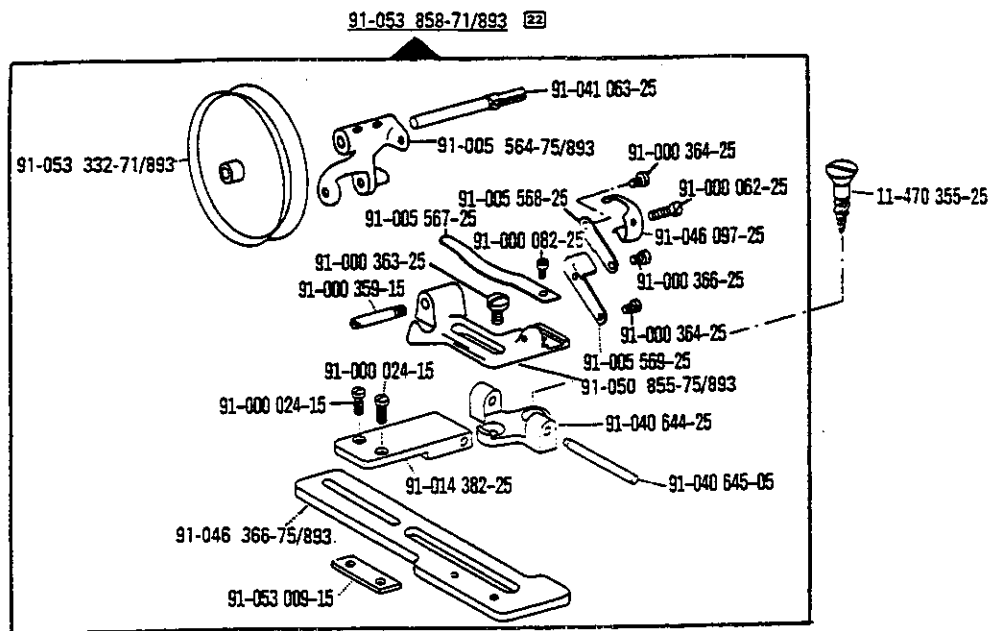
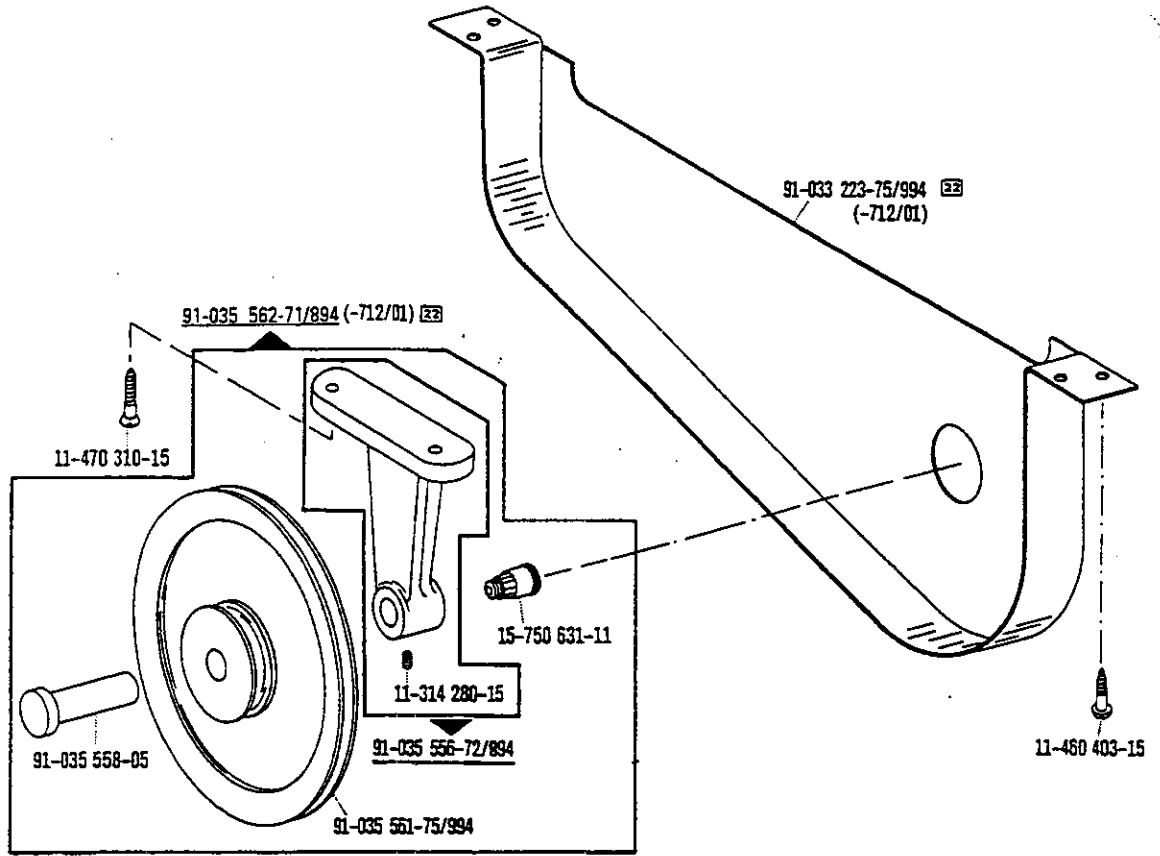

Basisteile
 Basic parts
 Pièces de ba
 Piezas básica

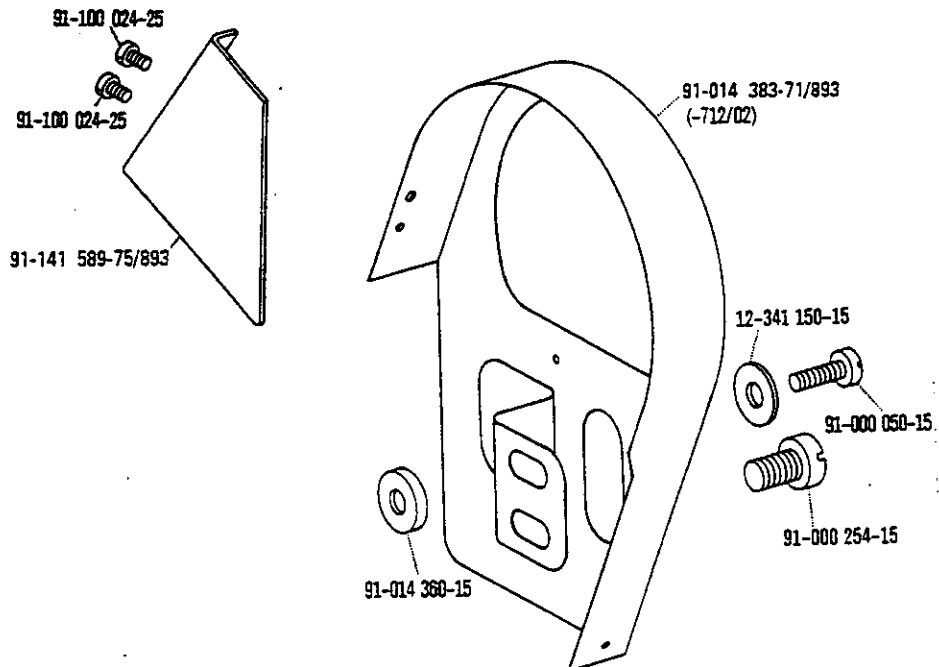
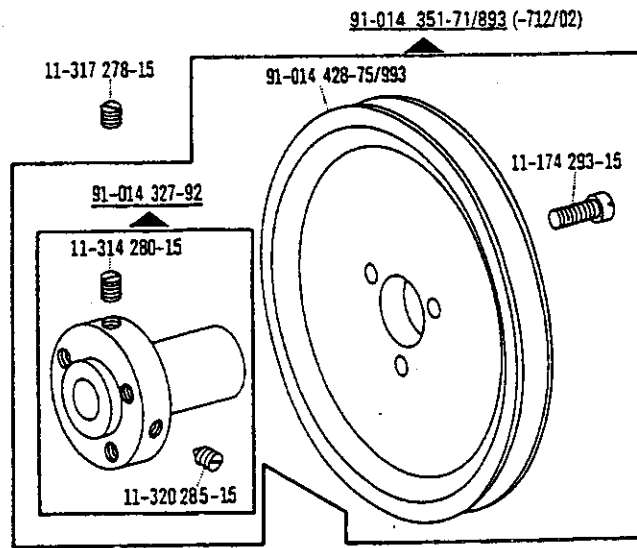

Basisteile
 Basic parts
 Pièces de base
 Piezas básicas

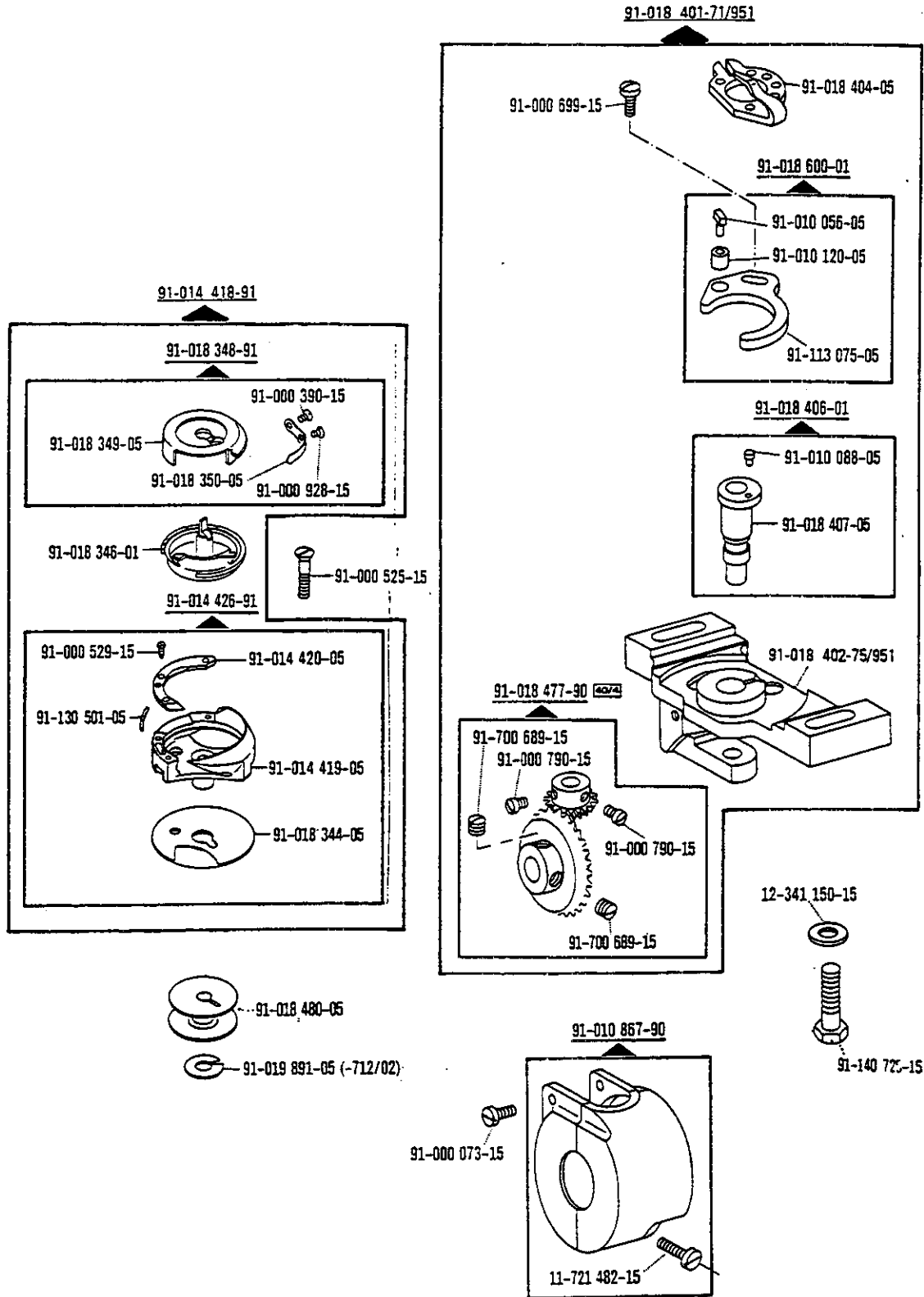

Basisteile
 Basic parts
 Pièces de base
 Piezas básicas

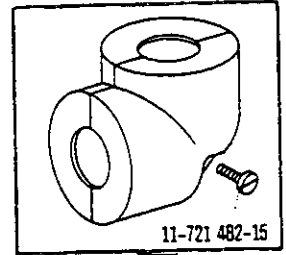
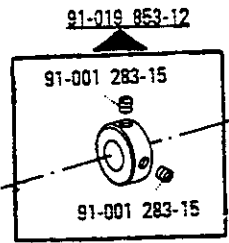
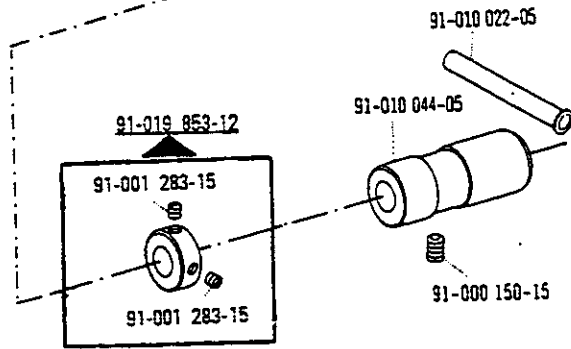
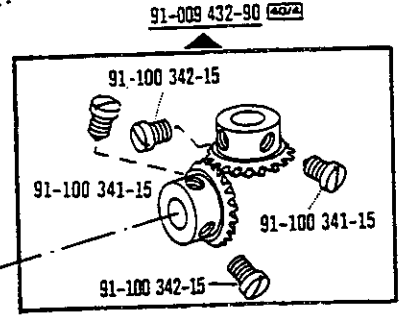
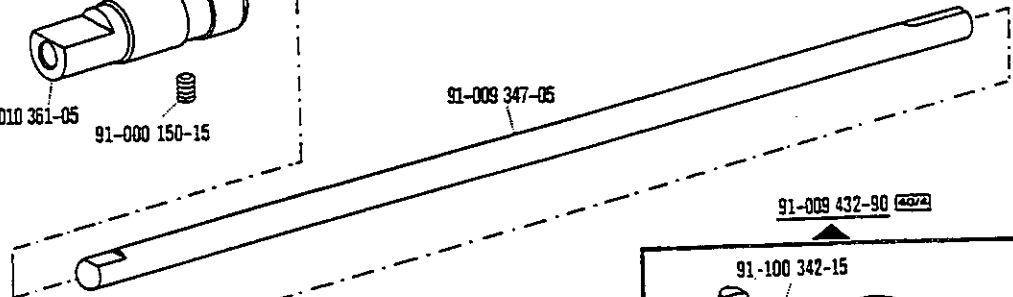
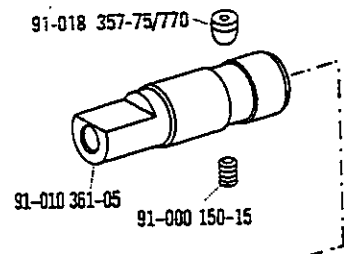
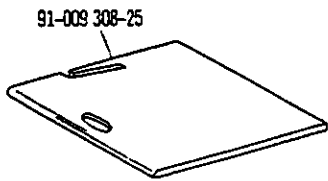
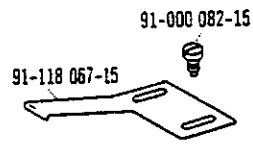
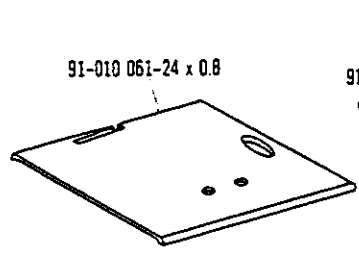
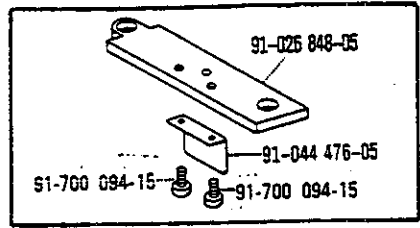

91-019 619-90

Basisteile
 Basic parts
 Pièces de base
 Piezas básicas

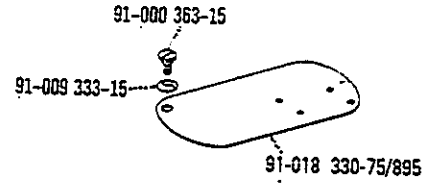
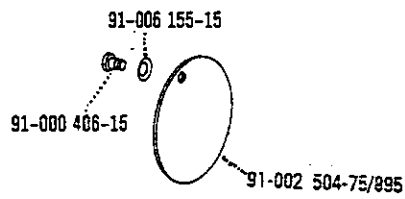

91-018 652-71/895

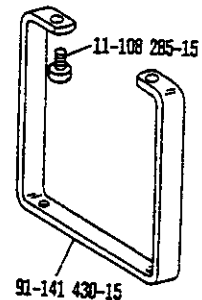
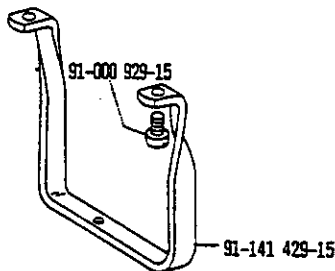
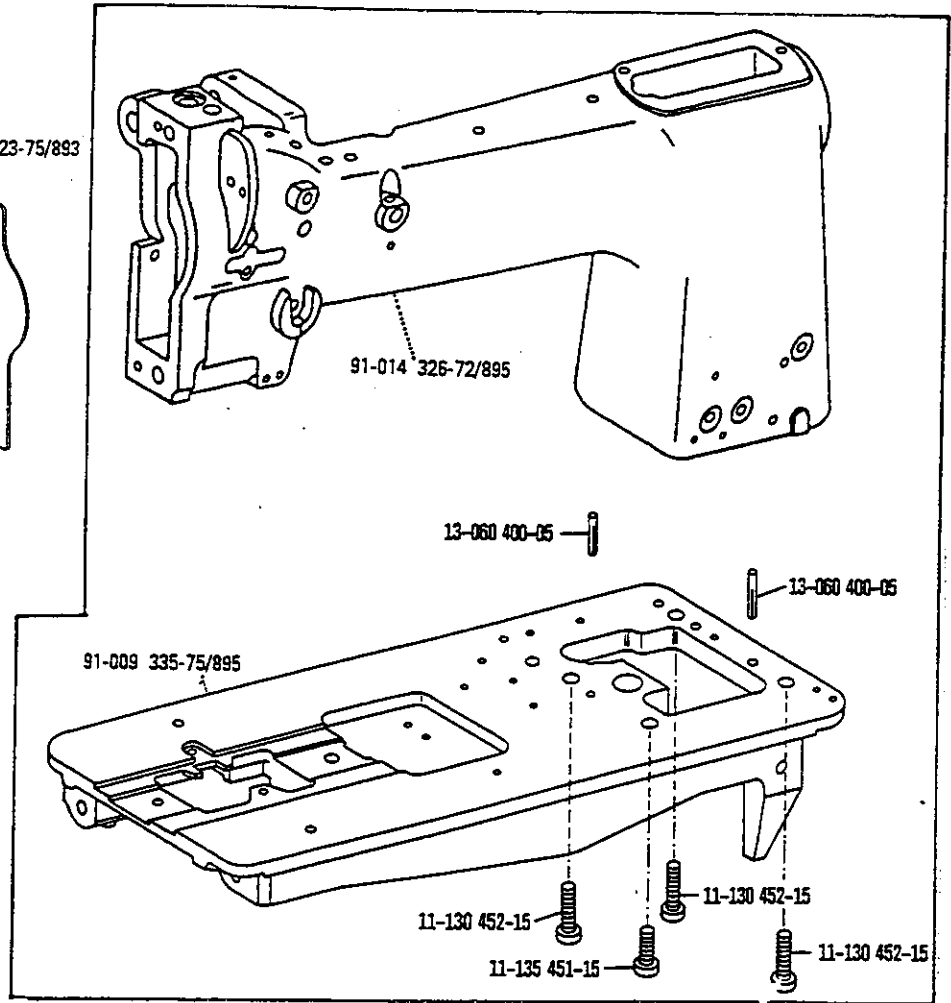
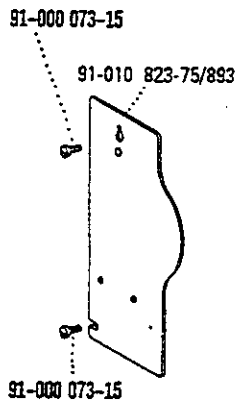

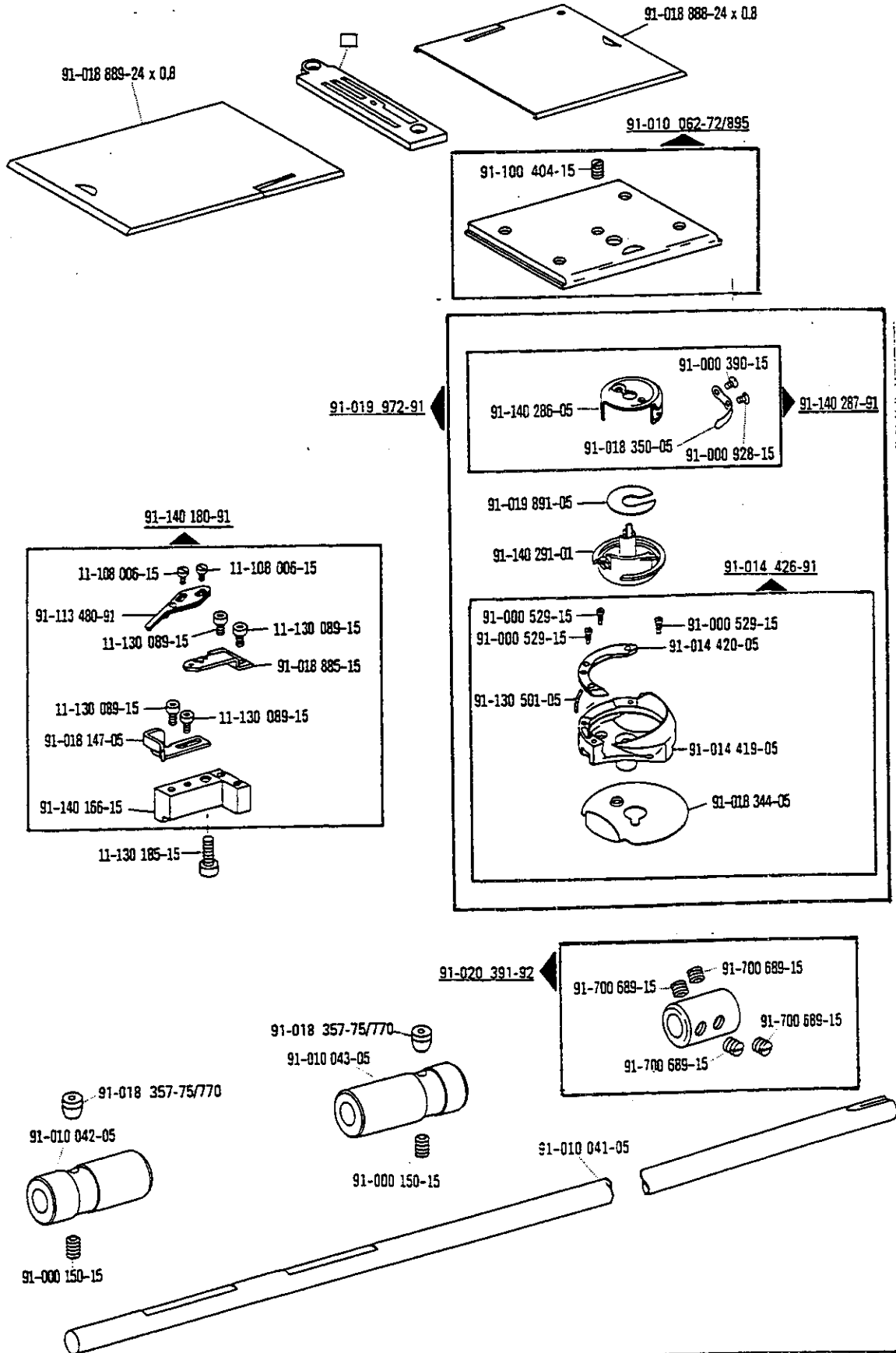

-900/

900/..

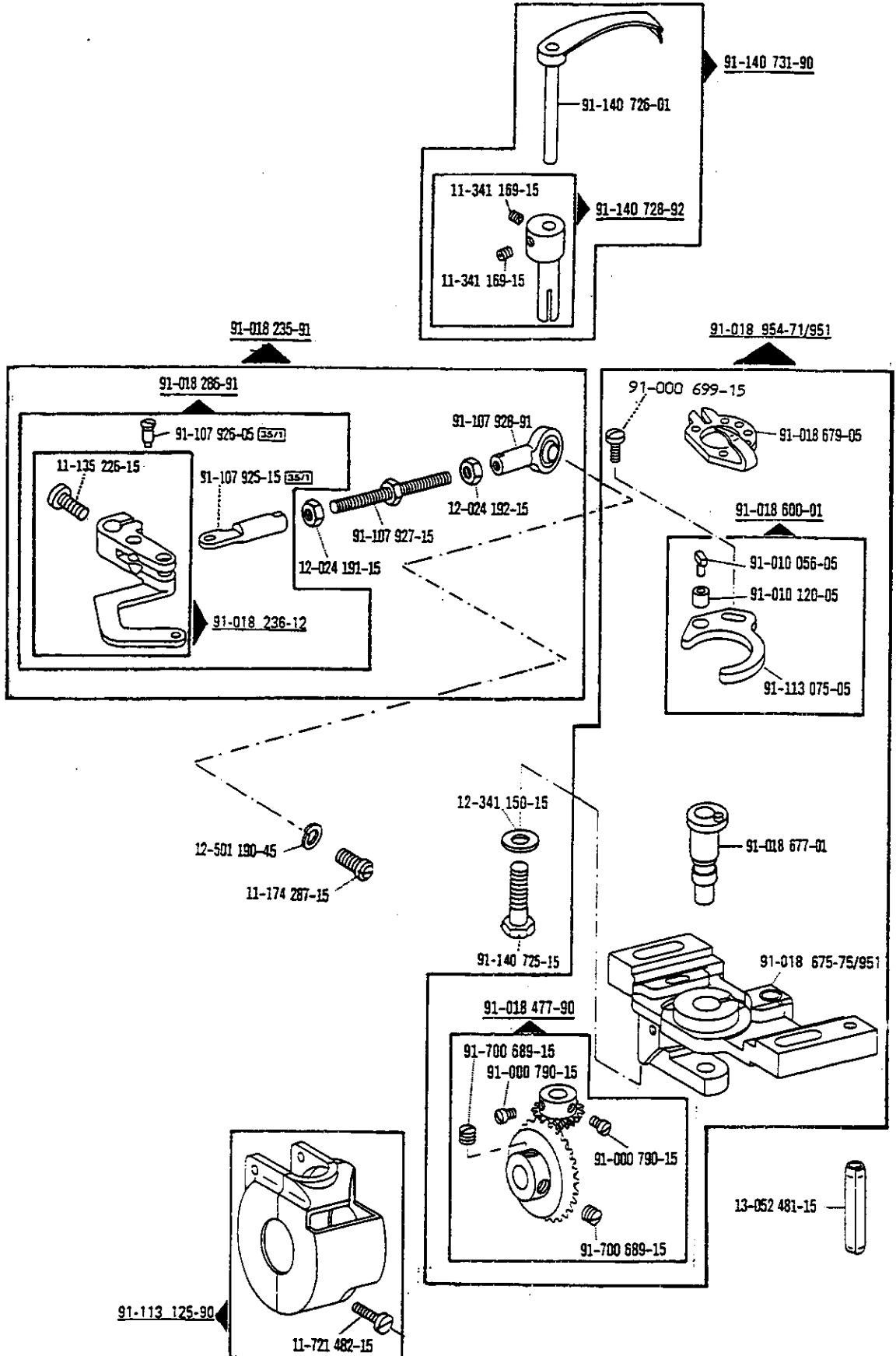

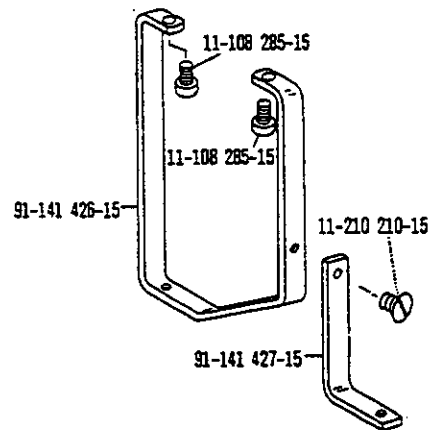
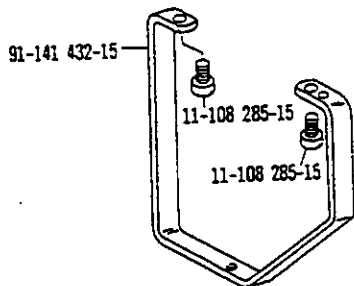
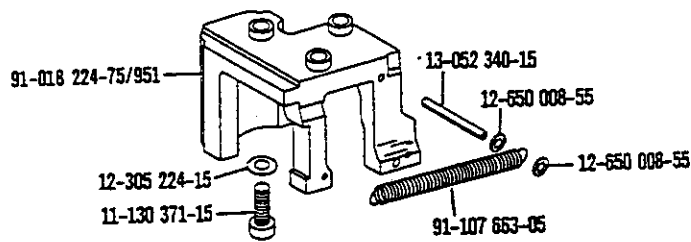
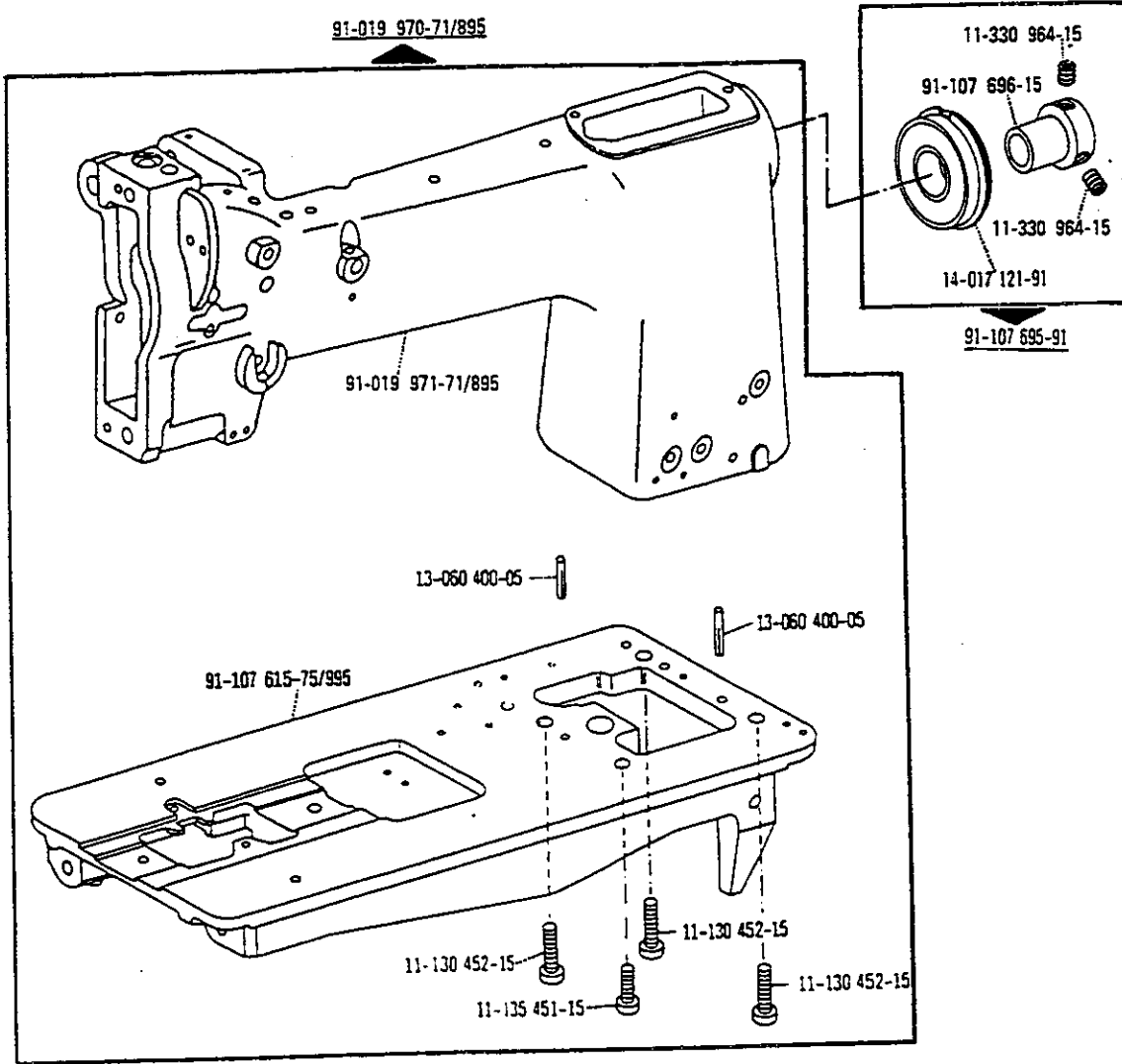

900/..

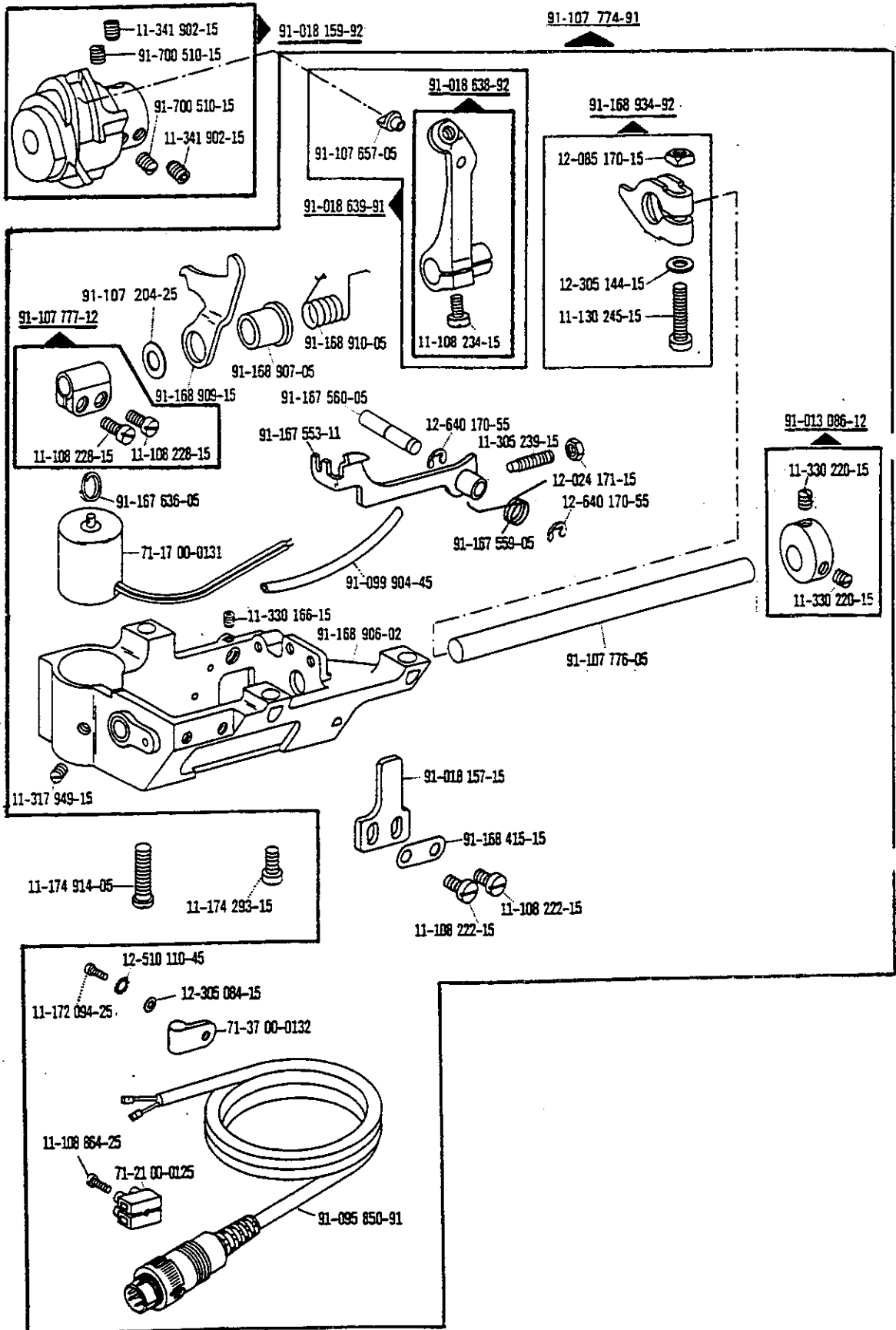

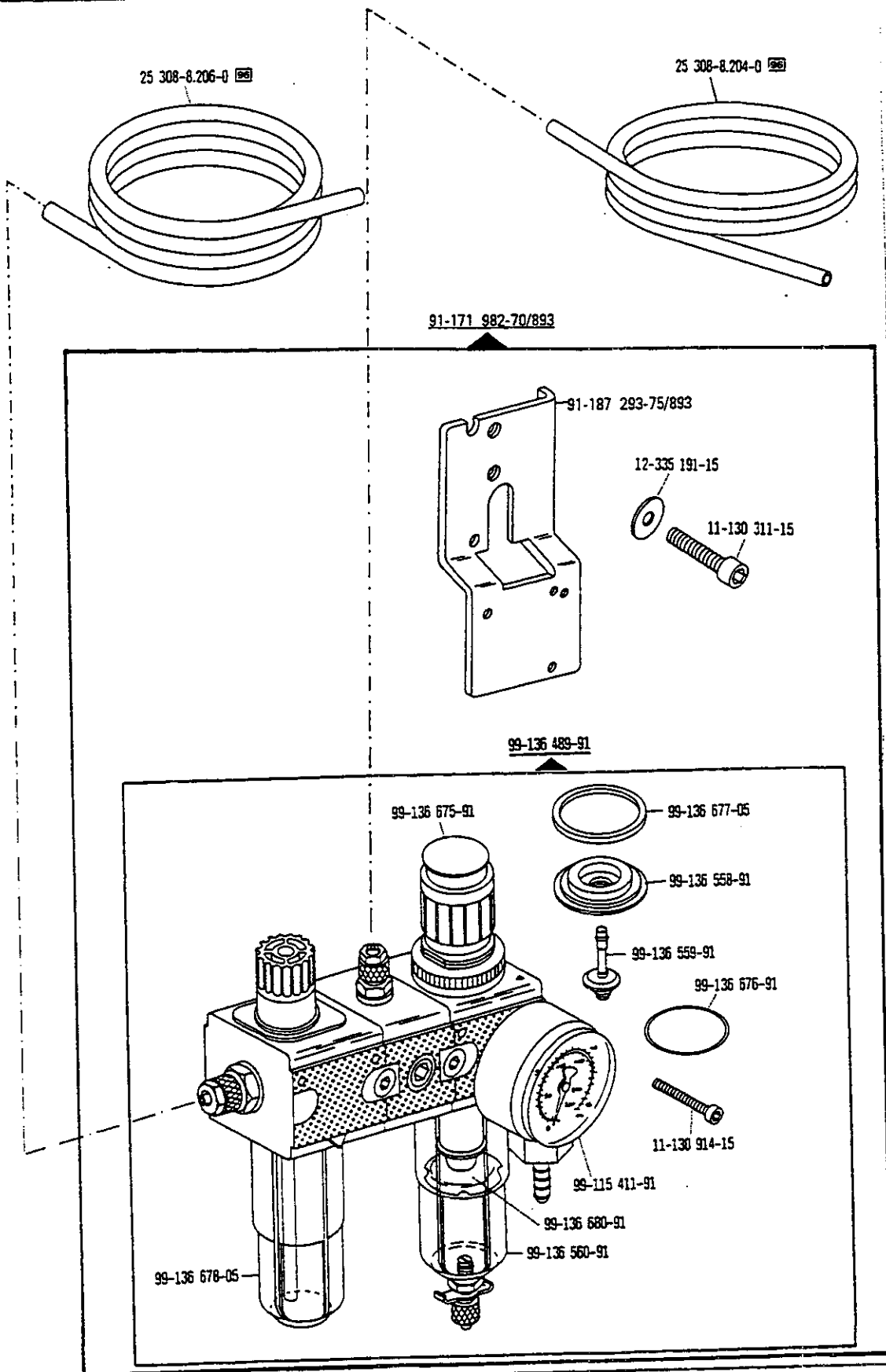

-925/..

□ siehe Erläuterungen Register
 see explanations in section
 voir légende registre
 ver explicaciones del registro

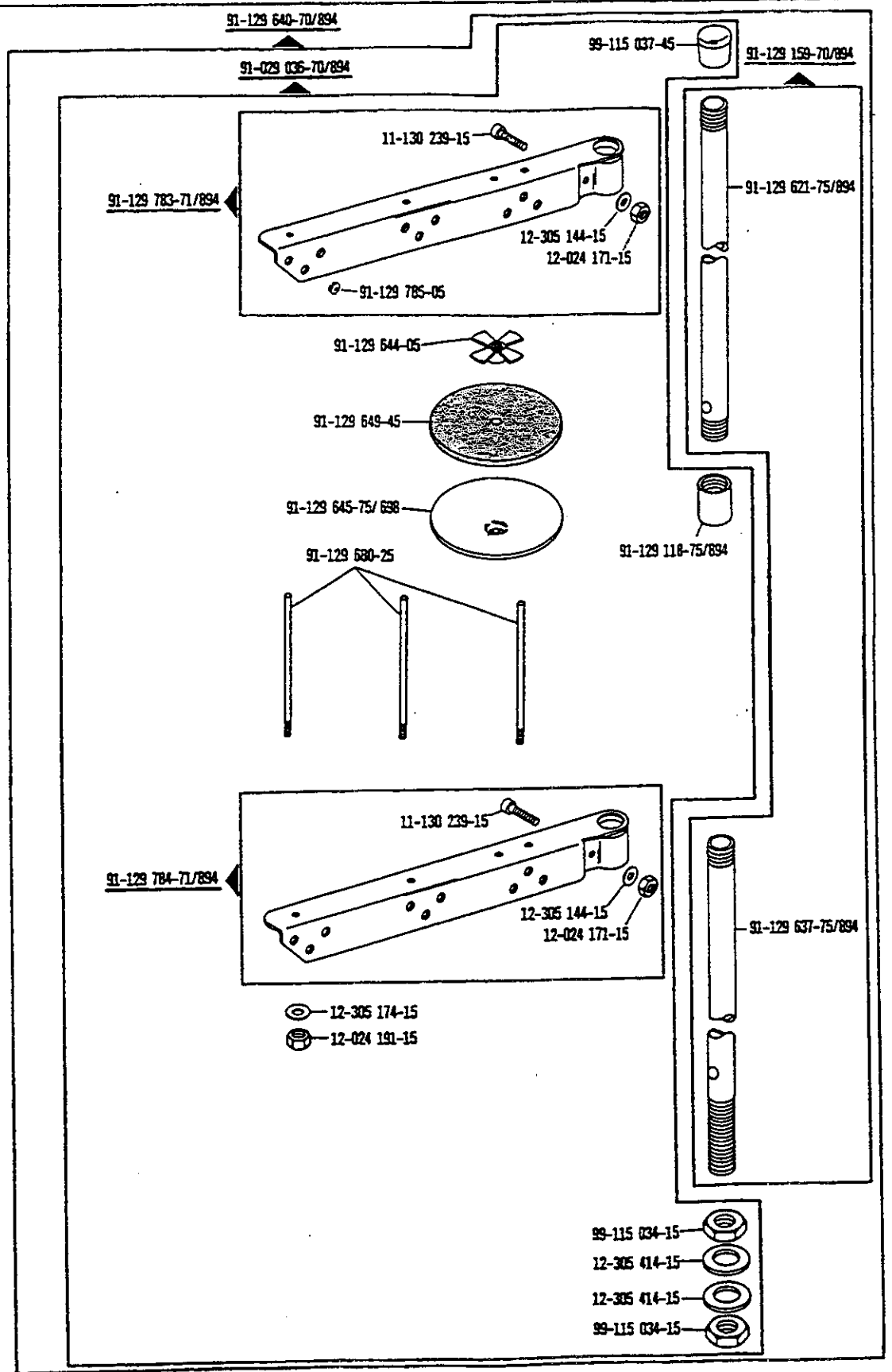

siehe Erläuterungen Register
 see explanations in section
 voir légende registre
 ver explicaciones del registro

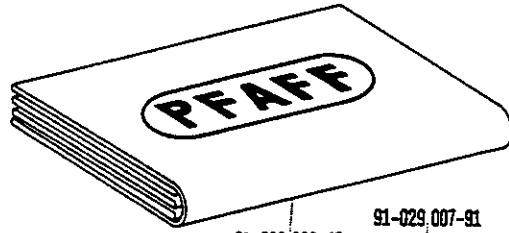

91-029 946-91



91-029 007-91

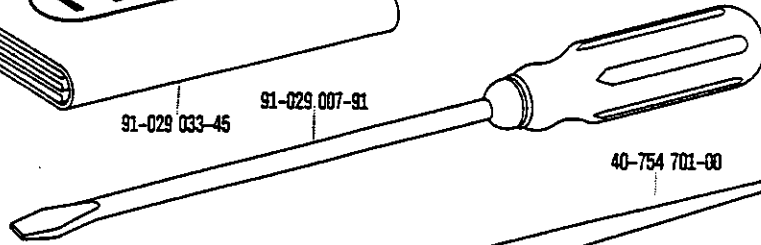

40-754 701-00



91-029 394-01

leer
 empty
 vide
 vacia

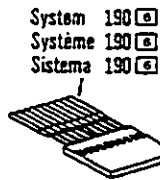
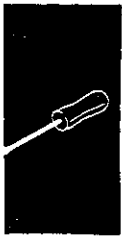
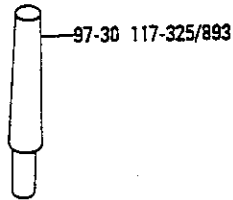
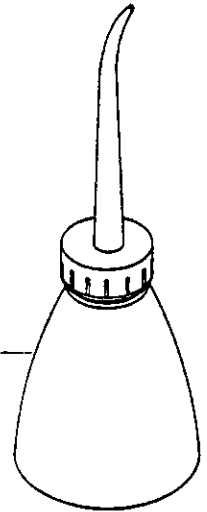

91-038 800-71/699

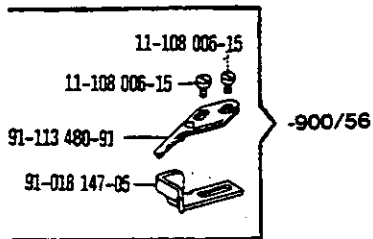
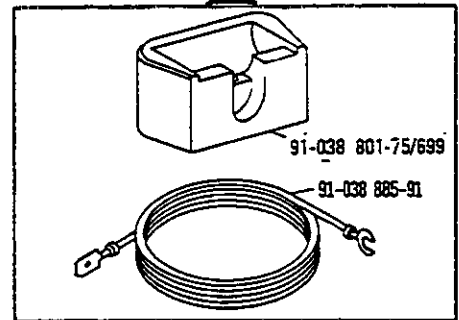

91-027 651-75/699

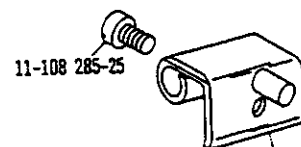
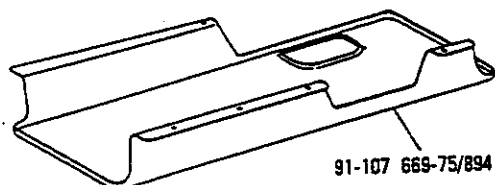
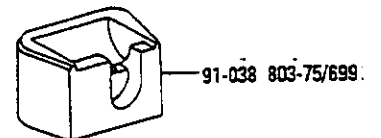
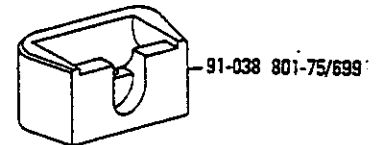
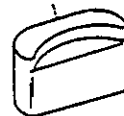

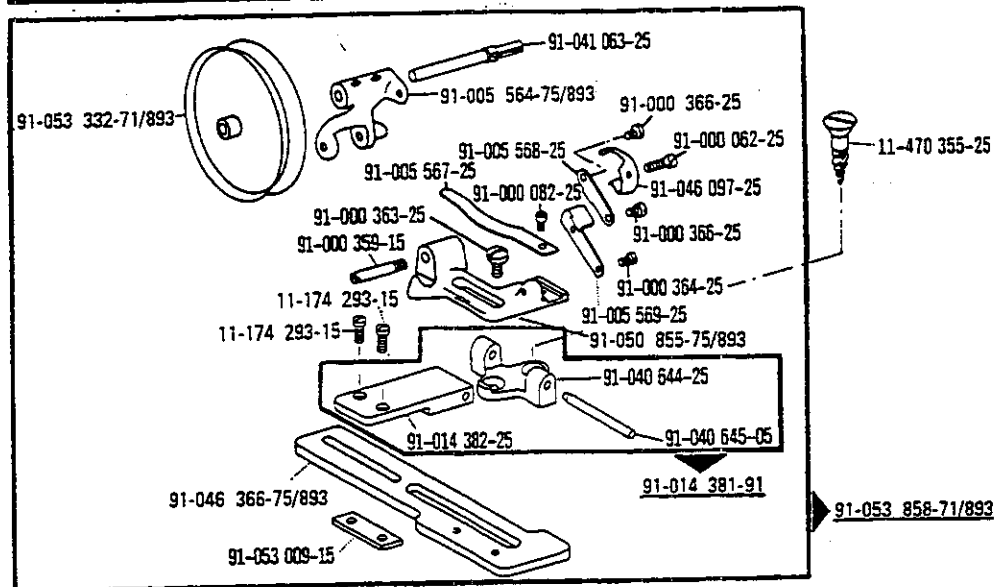
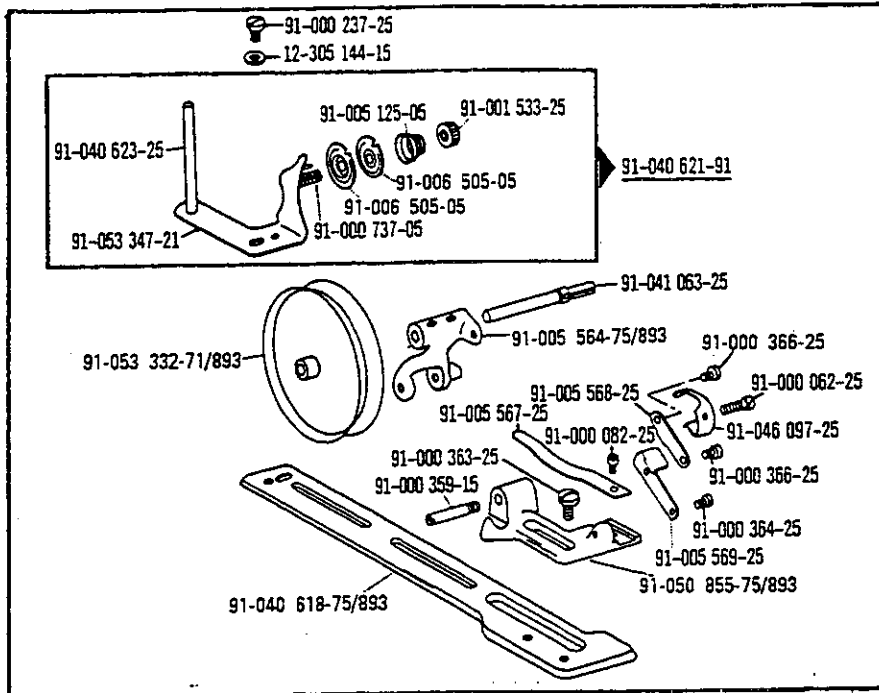

Einstellehren
Adjustment gauges
Calibres
Calibres de ajuste

61-111 600-35

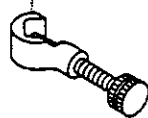

61-111 600-01

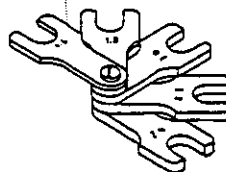

61-111 630-14

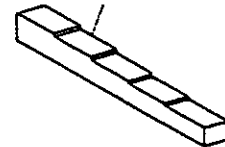

Motoranschlussbau

Motor connection kit

Jeu de pièces à raccorder le moteur

Juego de piezas de conexión del motor

PFAFF 543-712/..

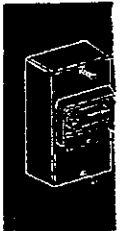
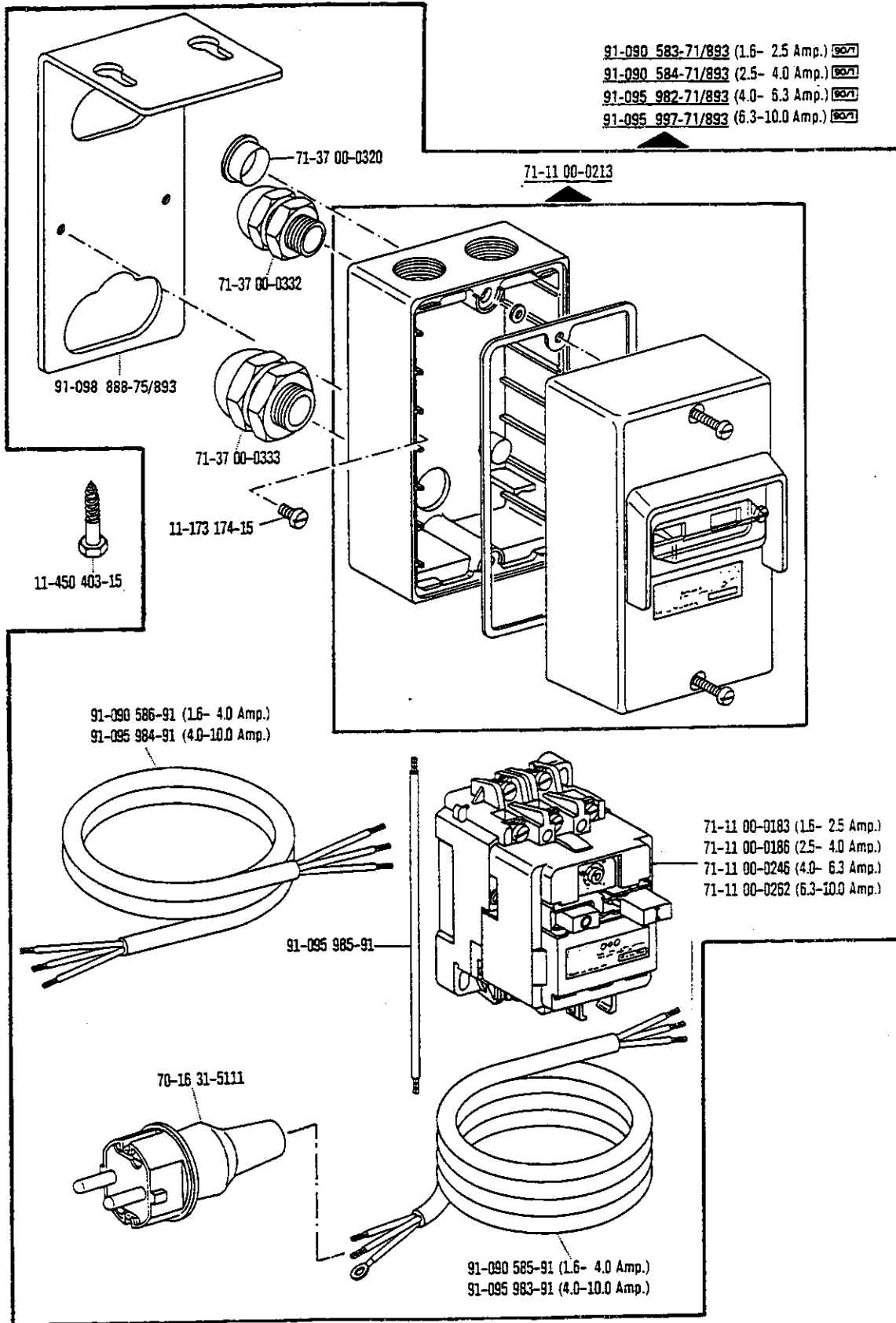

siehe Erläuterungen Register A-199
 see explanations in section
 voir légende registre
 ver explicaciones del registro

Motor connection kit



Jeu de pièces à raccorder le moteur

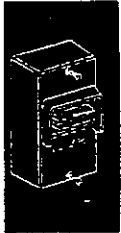
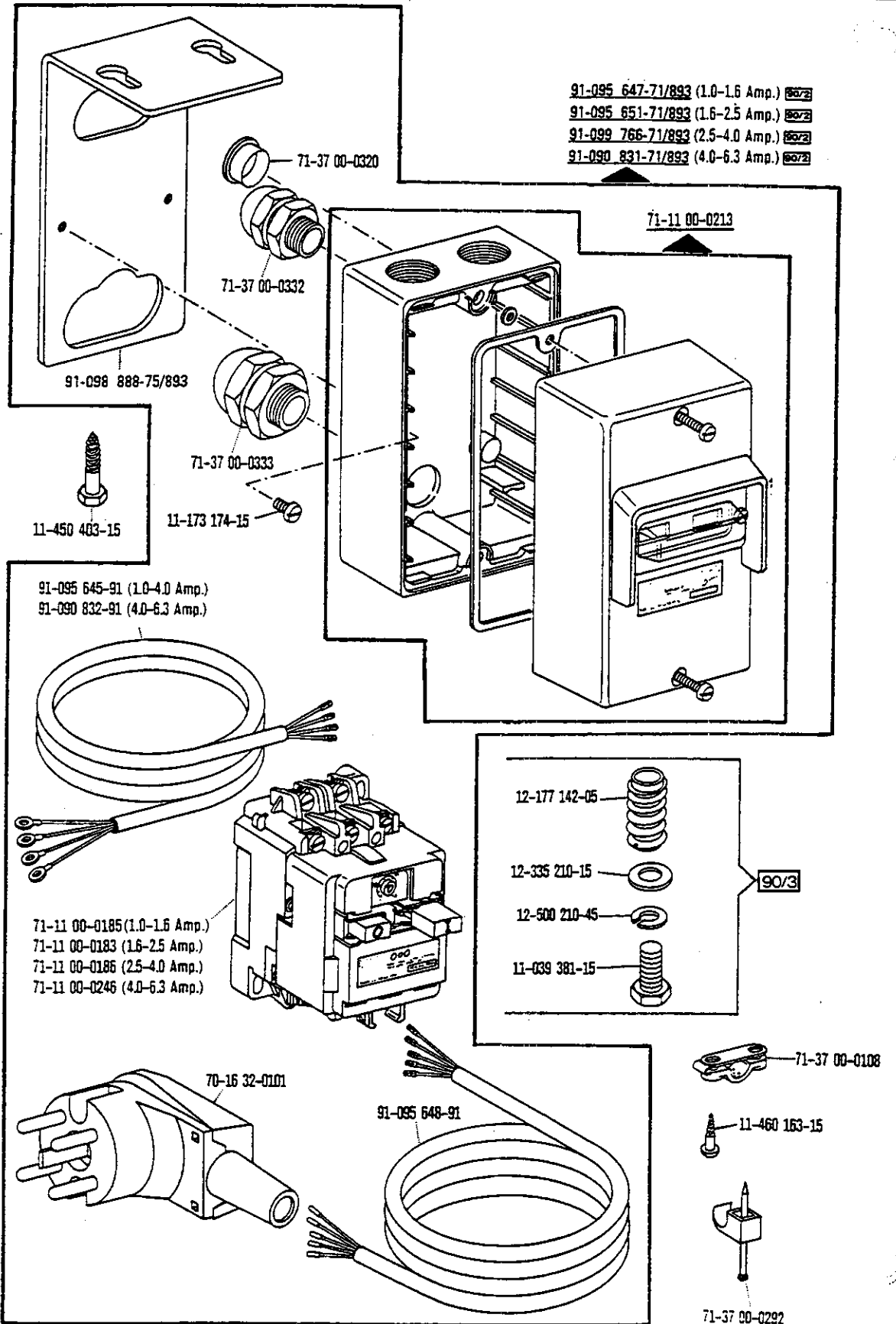

Juego de piezas de conexión del motor

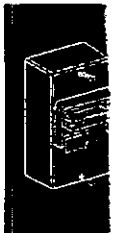
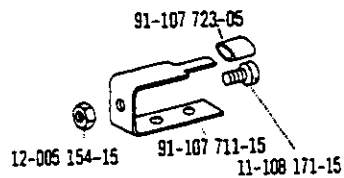
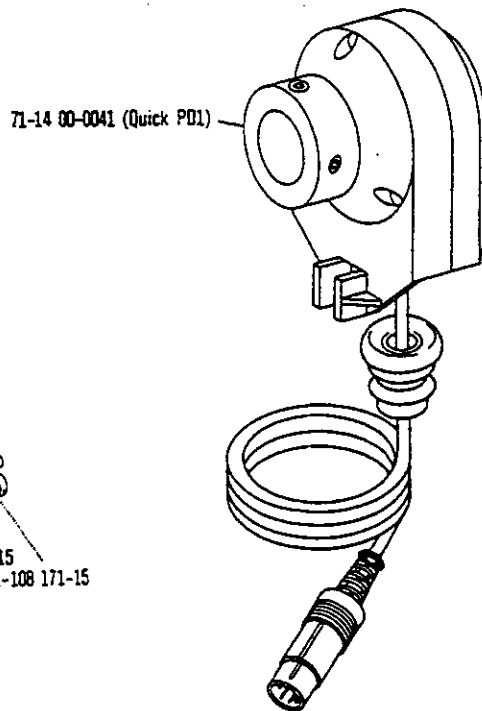
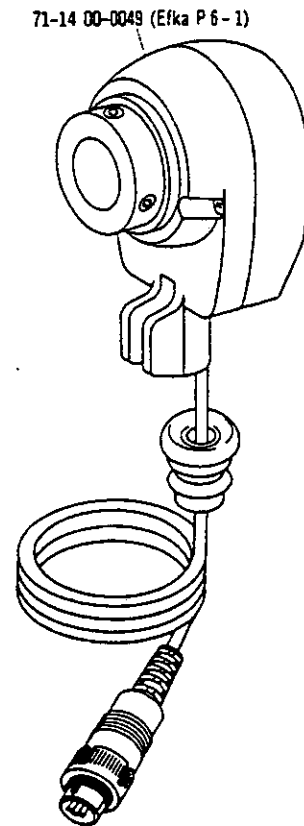
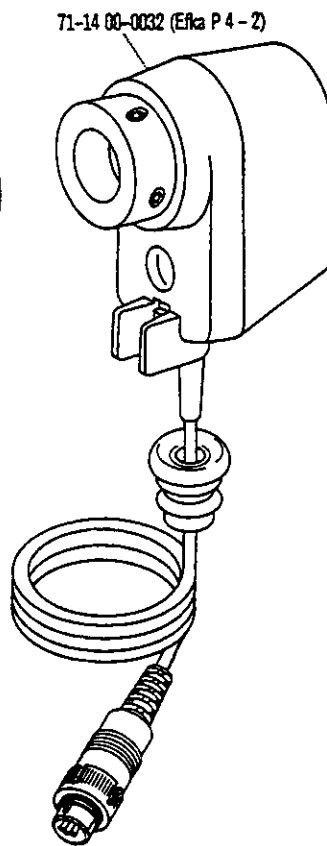
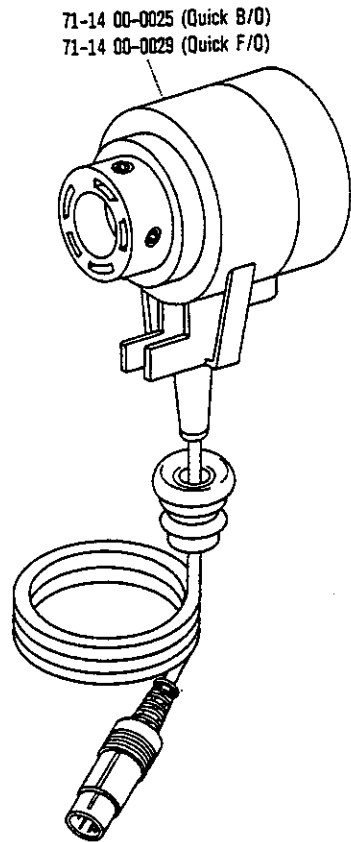
PFAFF 543-712/L





Öl Oil Huile Aceite	Mittelpunkts- Viskosität bei: Mean viscosity at: Viscosité moyenne à: Viscosidad media a:		Dichte bei: Density of: Densité à: Densidad a:		Bestellnummer für Behälter mit: Part number for can with: Numéro de commande pour récipients avec: Número de pedido para recipientes con:			
	°C	mm²/s	°C	g/cm³ (g/ml)	Liter Litre Litros			
280-1-120 144	40	22.0	15	80(ml)			91-027 630-91	
				0.25			91-129 916-91	
				0.865	1			91-129 917-91
				5			91-129 919-91	
				10			91-129 920-91	

Fett Grease Graisse Grasa	Penetration Penetration Pénétration Penetración	Tropfpunkt Drip-point Point de suintement Punto de goteo	Bestellnummer für Behälter mit: Part number for can with: Numéro de commande pour récipients avec: Número de pedido para recipientes con:				
			mm/10	°C	kg		
280-1-120 24	375-405	150	0.5		280-1-120 243		
			1				



No.	Seite Page Pages Página	No.	Seite Page Pages Página	No.	Seite Page Pages Página	No.	Seite Page Pages Página
11-039 381-15	28	11-320 285-15	13	12-640 170-55	20	71-37 00-0333	27, 28
11-108 006-15	17	11-330 166-15	20	12-650 008-55	19	91-000 017-15	10
11-108 006-15	24	11-330 220-15	20	13-052 340-15	19	91-000 024-15	12
11-108 171-15	29	11-330 964-15	19	13-052 481-15	18	91-000 050-15	11, 13
11-108 198-15	10	11-341 169-15	18	13-060 400-05	16, 19	91-000 058-15	7
11-108 207-15	10	11-341 902-15	20	14-017 121-91	19	91-000 062-25	12, 25
11-108 222-15	20	11-450 403-15	27, 28	15-750 631-11	12	91-000 072-15	7
11-108 225-15	9	11-460 109-15	24	16-049 040-11	10	91-000 073-15	14, 16
11-108 228-15	9	11-460 163-15	28	16-437 030-05	31	91-000 082-15	7, 8, 15
11-108 228-15	20	11-460 403-15	12	16-437 070-05	31	91-000 082-25	12, 25
11-108 234-15	20	11-470 310-15	12	16-437 909-05	31	91-000 083-15	9
11-108 285-15	16, 19	11-470 355-25	12, 25	40-754 701-00	24	91-000 089-15	7
11-108 285-25	24	11-721 482-15	14, 15, 18	61-111 600-01	25	91-000 150-15	7, 9, 11,
11-108 864-25	20	12-005 154-15	29	61-111 600-35	25		15, 17
11-130 089-15	17	12-024 151-15	10	61-111 630-14	25	91-000 152-15	7, 9
11-130 185-15	17	12-024 151-25	9	70-16 31-5111	27	91-000 153-15	10
11-130 239-15	23	12-024 171-15	10, 20, 23	70-16 32-0101	28	91-000 171-15	10
11-130 245-15	20	12-024 191-15	18, 23	71-11 00-0183	27, 28	91-000 172-25	8
11-130 311-15	21	12-024 192-15	18	71-11 00-0185	28	91-000 195-15	7
11-130 371-15	19	12-085 170-15	20	71-11 00-0186	27, 28	91-000 237-25	25
11-130 452-15	16, 19	12-177 142-05	28	71-11 00-0213	27, 28	91-000 243-15	7, 8
11-130 914-15	21	12-305 084-15	20	71-11 00-0246	27, 28	91-000 254-15	13
11-135 225-15	18	12-305 144-15	20, 23, 25	71-11 00-0262	27	91-000 278-15	7
11-135 451-15	16, 19	12-305 174-15	23	71-14 00-0025	29	91-000 321-15	10
11-172 094-25	20	12-305 224-15	19	71-14 00-0029	29	91-000 323-15	9
11-173 174-15	7, 27, 28	12-305 414-15	23	71-14 00-0032	29	91-000 335-15	8
11-173 174-25	9	12-315 170-15	9	71-14 00-0041	29	91-000 359-15	12, 25
11-174 287-15	18	12-335 191-15	21	71-14 00-0049	29	91-000 363-15	16
11-174 293-15	13, 20, 25	12-335 210-15	28	71-17 00-0131	20	91-000 363-25	12, 25
11-174 914-05	20	12-341 090-15	7	71-21 00-0125	20	91-000 364-25	12, 25
11-210 210-15	19	12-341 150-15	8, 11, 13,	71-27 00-0320	28	91-000 366-25	12, 25
11-305 239-15	20		14, 18	71-37 00-0108	28	91-000 388-15	8
11-314 280-11	12	12-500 210-45	28	71-37 00-0132	20	91-000 390-15	14, 17
11-314 280-15	13	12-501 190-45	18	71-37 00-0292	28	91-000 405-15	9
11-317 278-15	13	12-510 110-45	20	71-37 00-0320	27	91-000 406-15	16
11-317 949-15	20	12-610 210-45	7	71-37 00-0332	27, 28	91-000 456-15	9



No.	Seite Page Pages Página	No.	Seite Page Pages Página	No.	Seite Page Pages Página	No.	Seite Page Pages Página
91-000 510-15	9	91-005 568-25	12, 25	91-010 196-05	9	91-011 932-05	10
91-000 511-15	9	91-005 569-25	12, 25	91-010 360-05	9	91-011 933-15	10
91-000 524-05	8	91-005 604-05	11	91-010 361-05	15	91-011 936-71/893	10
91-000 525-15	14	91-005 622-05	11	91-010 546-05	11	91-011 942-01	10
91-000 529-15	14, 17	91-006 155-15	11, 16	91-010 596-05	9	91-013 086-12	20
91-000 636-25	7	91-006 505-05	25	91-010 823-75/893	16	91-014 318-05	9
91-000 689-15	9	91-008 003-05	9	91-010 867-90	14	91-014 320-92	7
91-000 697-05	9	91-008 004-05	9	91-010 930-05	7	91-014 324-25	9
91-000 699-15	14, 18	91-008 005-05	9	91-011 893-05	8	91-014 326-72/895	16
91-000 737-05	25	91-008 008-92	7	91-011 729-92	9	91-014 327-92	13
91-000 790-15	14, 18	91-008 020-05	7	91-011 744-92	7	91-014 341-91	8
91-000 803-15	7	91-008 064-05	7	91-011 754-05	8	91-014 342-05	8
91-000 871-15	10	91-009 119-05	7	91-011 778-15	9	91-014 345-45	8
91-000 872-15	10	91-009 148-05	7	91-011 853-05	9	91-014 346-05	8
91-000 873-15	10	91-009 308-25	15	91-011 854-05	9	91-014 351-71/893	13
91-000 879-15	10	91-009 333-15	16	91-011 857-05	10	91-014 352-45	8
91-000 889-15	11	91-009 335-75/895	16	91-011 858-75/895	10	91-014 357-92	9
91-000 905-15	8	91-009 347-05	15	91-011 859-05	10	91-014 358-45	9
91-000 928-15	14, 17	91-009 390-75/893	7	91-011 864-05	10	91-014 359-91	9
91-000 929-15	16	91-009 432-90	15	91-011 865-75/893	10	91-014 360-15	13
91-001 283-15	15	91-010 002-05	9	91-011 870-05	7	91-014 361-71/893	11
91-001 511-15	9, 10	91-010 016-05	11	91-011 875-05	10	91-014 376-91	9
91-001 522-25	8, 9	91-010 017-05	11	91-011 887-91	9	91-014 377-71/893	11
91-001 533-25	25	91-010 018-05	11	91-011 889-05	9	91-014 380-75/893	11
91-001 548-25	11	91-010 022-05	15	91-011 891-02	8	91-014 381-91	25
91-001 636-25	8	91-010 023-05	8	91-011 892-05	8	91-014 382-25	12, 25
91-001 847-05	10	91-010 026-21	8	91-011 894-05	8	91-014 383-71/893	13
91-002 025-92	4	91-010 041-05	17	91-011 901-05	8	91-014 388-12	7
91-002 065-05	8	91-010 042-05	17	91-011 902-92	9	91-014 396-05	7
91-002 203-05	11	91-010 043-05	17	91-011 913-05	7	91-014 397-25	7
91-002 204-25	11	91-010 044-05	9, 15	91-011 914-05	7	91-014 398-71/895	10
91-002 205-05	11	91-010 055-05	14, 18	91-011 916-05	7	91-014 399-75/895	10
91-002 504-75/895	16	91-010 061-24	15	91-011 920-05	7	91-014 400-15	10
91-005 125-05	25	91-010 062-72/895	17	91-011 922-91	7	91-014 401-15	10
91-005 564-75/893	12, 25	91-010 088-05	14	91-011 924-91	8	91-014 403-91	10
91-005 567-25	12, 25	91-010 120-05	14, 18	91-011 929-15	7	91-014 413-92	9



No.	Seite Page Pages Página	No.	Seite Page Pages Página	No.	Seite Page Pages Página	No.	Seite Page Pages Página
91-014 414-15	9	91-018 460-90	11	91-033 223-75/894	12	91-069 043-15	7
91-014 418-91	14	91-018 477-90	14, 18	91-033 915-21	24	91-069 056-05	9
91-014 419-05	14, 17	91-018 480-05	14, 24	91-035 556-72/994	12	91-069 471-25	9
91-014 420-05	14, 17	91-018 600-01	14, 18	91-035 558-05	12	91-069 730-05	10
91-014 421-71/895	10	91-018 638-92	20	91-035 561-75/994	12	91-069 992-25	9
91-014 422-70/895	10	91-018 639-91	20	91-035 562-71/894	12	91-090 583-71/893	27
91-014 426-91	14, 17	91-018 652-71/895	16	91-038 800-71/699	24	91-090 584-71/893	27
91-014 427-05	10	91-018 653-75/770	9	91-038 801-75/699	24	91-090 585-91	27
91-014 428-75/893	13	91-018 675-75/951	18	91-038 803-75/699	24	91-090 586-91	27
91-014 429-01	7	91-018 677-01	18	91-038 885-91	24	91-090 831-71/893	28
91-016 137-25	10	91-018 679-05	18	91-040 618-75/893	25	91-090 832-91	28
91-018 147-05	17, 24	91-018 885-15	17	91-040 621-91	25	91-095 647-71/893	28
91-018 157-15	20	91-018 888-24	17	91-040 623-25	25	91-095 648-91	28
91-018 159-92	20	91-018 889-24	17	91-040 644-25	12, 25	91-095 649-91	28
91-018 224-75/951	19	91-018 954-71/951	18	91-040 645-05	12, 25	91-095 651-71/893	28
91-018 235-91	18	91-019 619-90	15	91-041 063-25	12, 25	91-095 850-91	20
91-018 236-12	18	91-019 676-05	7	91-041 085-71/893	25	91-095 982-71/893	27
91-018 286-91	18	91-019 853-12	15	91-044 476-05	15	91-095 983-91	27
91-018 328-91	11	91-019 891-05	14, 17	91-046 097-25	12, 25	91-095 984-91	27
91-018 329-25	11	91-019 970-71/895	19	91-046 366-75/893	12, 25	91-095 985-91	27
91-018 330-75/895	16	91-019 971-71/895	19	91-050 140-05	11	91-095 997-71/893	27
91-018 344-05	14, 17	91-019 972-91	17	91-050 855-75/893	12, 25	91-098 888-75/893	27, 28
91-018 346-01	14	91-020 119-05	7	91-053 009-15	12, 25	91-099 766-71/893	28
91-018 348-91	14	91-020 391-92	17	91-053 332-71/893	12, 25	91-099 904-45	20
91-018 349-05	14	91-020 715-91	11	91-053 347-21	25	91-100 024-25	11, 13
91-018 350-05	14, 17	91-023 065-05	10	91-053 858-71/893	12, 25	91-100 050-15	11
91-018 357-75/770	15, 17	91-026 848-05	15	91-055 253-15	7	91-100 222-15	7
91-018 358-75/770	9	91-027 630-91	32	91-056 193-25	9	91-100 341-15	11, 15
91-018 359-75/770	9	91-027 651-75/699	24	91-056 760-05	9	91-100 342-15	11, 15
91-018 401-71/951	14	91-029 007-91	24	91-057 182-05	4	91-100 404-15	17
91-018 402-75/951	14	91-029 033-45	24	91-058 012-91	4, 15	91-101 757-05	10
91-018 404-05	14	91-029 036-70/994	23	91-061 005-05	7	91-101 907-01	9
91-018 406-01	14	91-029 394-01	24	91-063 048-05	7	91-102 005-05	8
91-018 407-05	14	91-029 946-91	24	91-063 049-05	7	91-105 420-15	8
91-018 412-92	9	91-030 240-05	10	91-063 051-01	7	91-107 204-15	20
91-018 413-92	7	91-031 888-15	10	91-067 020-05	9	91-107 515-75/895	19



PFaff 543-712/..

No.	Seite Page Pages Página	No.	Seite Page Pages Página	No.	Seite Page Pages Página	No.	Seite Page Pages Página
91-107 657-05	20	91-130 501-05	14, 17	91-700 785-15	7		
91-107 663-05	19	91-140 166-15	17	91-701 636-25	8		
91-107 669-75/894	24	91-140 180-91	17	92-107 777-12	20		
91-107 695-91	19	91-140 286-05	17	97-30 117-325/893	24		
91-107 696-15	19	91-140 287-91	17	99-115 034-15	23		
91-107 711-15	29	91-140 291-01	17	99-115 037-45	23		
91-107 723-05	29	91-140 725-15	14, 18	99-115 411-91	21		
91-107 774-91	20	91-140 726-01	18	99-136 489-91	21		
91-107 776-05	20	91-140 728-92	18	99-136 558-91	21		
91-107 925-15	18	91-140 731-90	18	99-136 559-91	21		
91-107 926-05	18	91-141 426-15	19	99-136 560-91	21		
91-107 927-15	18	91-141 427-15	19	99-136 675-91	21		
91-107 928-91	18	91-141 429-15	16	99-136 676-91	21		
91-113 030-25	8	91-141 430-15	16	99-136 677-05	21		
91-113 075-05	14, 18	91-141 432-15	19	99-136 678-05	21		
91-113 125-90	18	91-141 589-75/893	13	99-136 680-91	21		
91-113 480-91	17, 24	91-157 404-21	4	25 308-8.204-0	21		
91-118 067-15	15	91-158 662-91	4, 17	25 308-8.206-0	21		
91-118 557-25	9	91-167 553-11	20	280-1-120 243	32		
91-123 134-72/894	31	91-167 559-05	20	280-1-120 144	32		
91-129 118-75/894	23	91-167 560-05	20				
91-129 159-70/894	23	91-167 636-05	20				
91-129 621-75/894	23	91-168 415-15	20				
91-129 637-75/894	23	91-168 906-02	20				
91-129 640-70/894	23	91-168 907-05	20				
91-129 644-05	23	91-168 909-15	20				
91-129 645-45	23	91-168 910-05	20				
91-129 649-45	23	91-168 934-92	20				
91-129 680-25	23	91-171 982-70/895	21				
91-129 763-71/894	23	91-176 332-25	8				
91-129 784-71/894	23	91-187 293-75/893	21				
91-129 785-05	23	91-700 094-15	15				
91-129 916-91	32	91-700 153-15	11				
91-129 917-91	32	91-700 388-15	7				
91-129 919-91	32	91-700 510-15	20				
91-129 920-91	32	91-700 689-15	14, 17, 18				



PFAFF