

# JUKI®

No. 0234-00

1987・3

AE1030S0PJB

model **MO-103N**

一本針縁かがり縫ミシン

Single Needle, Overedging Sewing Machine

ジューキロックミシン

**JUKI LOCK**

---

**PARTS BOOK**

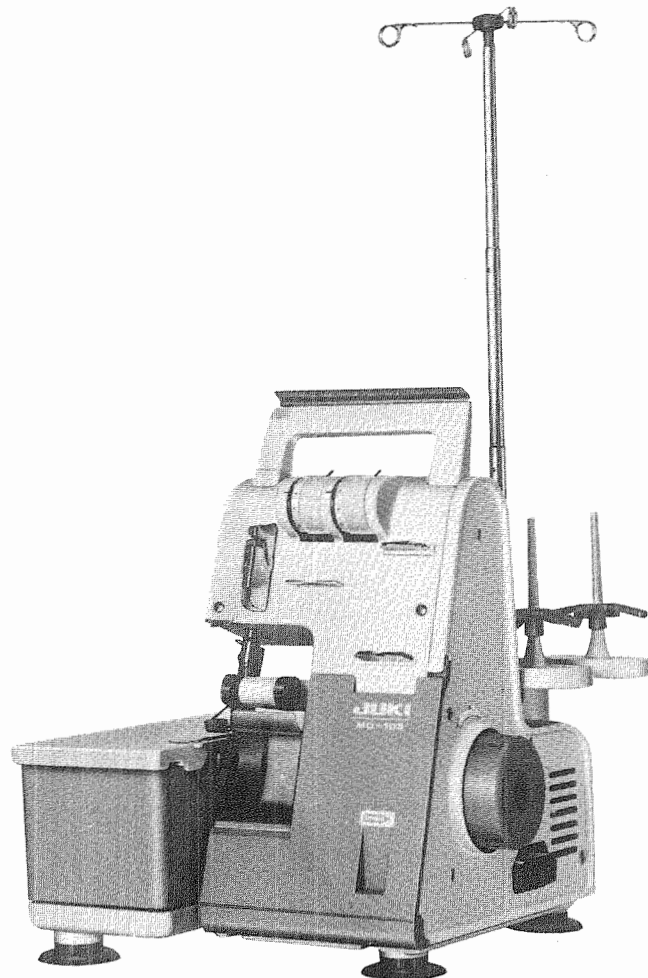

**TOKYO JUKI INDUSTRIAL CO. LTD.**

# HOW TO MAKE USE OF THIS PARTS BOOK

## パーツブックの見方

1. The part numbers of parts shown in the figure indicate the corresponding numbers (Ref. No.) shown by the Index.  
図に示された部品の品番は、図にふられているNo (Ref.No.)に対応するインデックスによって、その品番がわかります

### 2. Explanation of codes

記号の説明

#### 1) Codes on the "Note" column

"注記" 欄の記号

- ① ☆ . . . . . means this part is changed from the previous parts book.  
前回のパーツブックに対して今回変更された部品を意味します
- ② #01 . . . . . refer to the "Note" explanation at bottom of page.  
#01 ページ下の "注記" の説明を参照して下さい

#### 2) Codes on the "E.C. (Engineering change)" column

"変更年月" 欄の記号

- ① A.10/83 . . . . . Added from October, 1983  
1983年10月より追加された
- ② D.10/83 . . . . . Obsoleted from October, 1983  
1983年10月より削除された

③ When previous parts (Obsoleted part) and new parts (Added parts) are not interchangeable with each other:  
部品の互換性がない変更の場合

In this case, even obsoleted part (D.) can be ordered with the obsoleted part number, so select the parts with changed dates and place your orders.  
この場合は削除(D)された品番でもご注文できますから、変更年月により、いずれかの部品を選択してご注文下さい

Example (例)

Ref. No.	Note 注記	Part No. 品番	Description	E.C. 変更年月	品名	Amt. Req. 数量
1	☆	B1401-100-000	Needle bar	D.10/83	ハリボー	-
1-1	☆	B1401-100-000-A	Needle bar	A.10/83	ハリボー	1
2	☆	B1105-200-000	Frame cover	D.10/83	<del>B1105-300-000</del>	-
	☆	<u>B1105-300-000</u>	Frame cover	A.10/83	フレームカバー	1

④ In case when previous parts and new part are interchangeable with each other:  
部品の互換性がある場合の変更

In this case the new part number is replaced on the "品名 (Japanese)" column of the previous parts, so please order by the new part number.  
この場合は、旧部品の和文品名欄にそれにかわる新しい品番が記入してありますので、新しい品番でご注文下さい

#### ⑤ C.10/83

1	☆	<u>B1105-500-000</u>	Frame cover	C.10/83	<del>B1105-600-000</del>	1
		↑ Correct No. 正しい品番			↑ Wrong No. 誤り品番	

Please order by the correct part number.  
正しい品番でご注文下さい。

- ⑥ M.10/83 . . . . . The amount required is changed from October, 1983  
The new amount required is shown in the "Amt. Req." column.  
1983年10月より数量が変更になった。この場合数量欄には新しい数量が表示してあります

#### 3) Codes on the "Amt. Req." column

"数量" 欄の記号

- ① 2 . . . . . Indicates amount required is 2.  
数量、2個を表わします
- ② 2.0 . . . . . Indicates length in meters. (unit is meter)  
長さ、2メートルを表わします (単位はメートルです)
- ③ - . . . . . Indicates parts obsoleted from the parts book.  
このパーツブックから削除された部品です
- ④ (1) . . . . . Indicates sub parts which construct the assembly part.  
Assembly part is shown as "asm." and クミ in Japanese, in the "Description" column.  
組部品を構成している子部品を表わします。組部品は品名欄に英文で "asm." 和文でクミと表示してあります

### When Ordering The Spare Parts:

In order to ensure that we deliver the correct parts to you, please clearly state when ordering the corresponding PART NUMBER (ex. B1109-012-A00) and also the PARTS BOOK NUMBER (ex. 0010-01, given at the top right of the cover) or the MACHINE SERIAL NUMBER, because there are some parts which have been changed.

### 補用部品注文の際のご注意

このパーツブックに記載されている補用部品をご注文の際は、部品の番号(例えば、B1109-012-A00)でご注文下さい。合わせて、ご覧のパーツブックの管理番号(表紙右上、例えば、No0010-01)又は、機械番号をご連絡頂ければ幸いです。又、改良のため部品の一部が変更になる場合がありますのでご了承下さい。

CONTENTS  
目 次

1. FRAME COMPONENTS .....	1
フレーム関係	
2. MAIN SHAFT & FEED MECHANISM COMPONENTS .....	3
主軸・送り関係	
3. KNIFE COMPONENTS .....	4
メス関係	
4. NEEDLE BAR & PRESSER FOOT COMPONENTS .....	5
針棒・押工関係	
5. LOOPER COMPONENTS .....	7
ルーパ関係	
6. THREAD TENSION COMPONENTS .....	9
糸調子関係	
7. MOTOR COMPONENTS .....	10
モーター関係	
8. ACCESSORIES COMPONENTS .....	11
付属品関係	
NUMERICAL INDEX OF PARTS .....	12
索引	

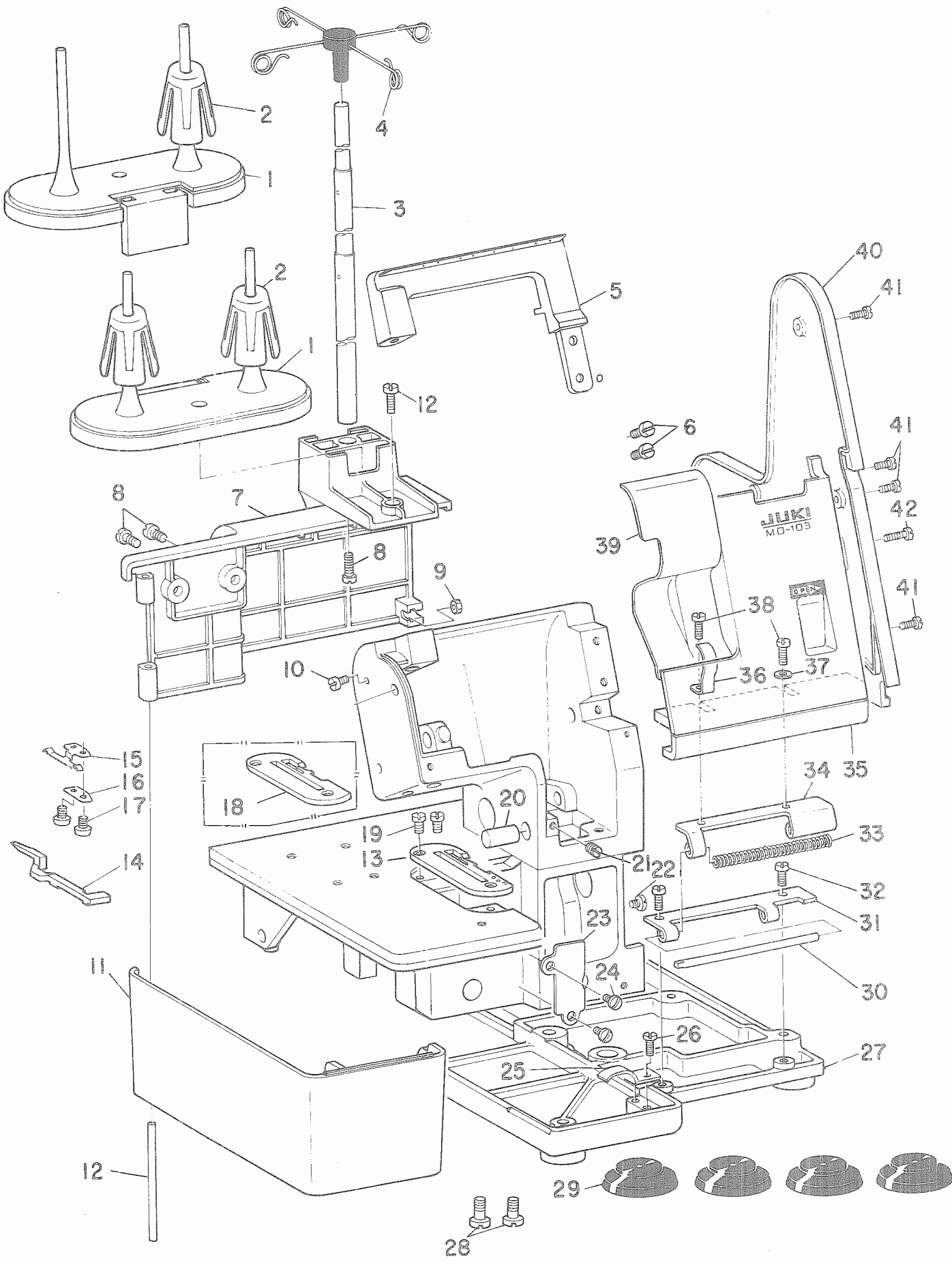

Ref. No.	Note 注記	Part No. 品番	Description	E. C. 変更年月	品名	Amt. Req. 数量
1		A1123-102-000	SPOOL HOLDER		イトダテケラ	2
2		A1120-202-000	SPOOL RETAINER		イトマキ フレトマ	3
3		A1124-102-000	SPOOL REST POLE		イトマキ イトダテホ-	1
4		A1127-104-000	THREAD GUIDE		イトマキ イトアソナイ	1
5		A1116-104-0AF	HANDLE ASM.		トツテ N	1
6		SS-6121210-SP	SCREW 3/16-28 L=12		ヒラネジ 3/16-28 L=9	2
7		A1105-102-00A	MOTOR COVER		モータカバー	1
8		SS-6121210-SP	SCREW 3/16-28 L=12		ヒラネジ 3/16-28 L=9	4
9		NS-6090310-SP	NUT 9/64-40		ロツカケナツト 9/64-40	1
10		SS-7090710-SL	SCREW 9/64-40 L=6.8		マルヒラネジ 9/64-40 L=6.3	1
11		A1106-103-00F	SIDE COVER N		ヨコカバー N	1
12		A1107-102-000	SIDE COVER HINGE PIN		ヨコカバー ヒンジシク	1
13		A1121-103-800	TROAT PLATE N		ニタツカカリハハハ ハリイタ N	1
14		A1130-203-000	LATCH FOR OVEREDGE WIDTH		カカリ チウウセツツメ	1
15		A1131-203-000	LATCH PRESSING SPRING		ツメネウエハハネ	1
16		A1132-203-000	LATCH PRESSING SPRING WASHER		ツメネウエハハネツマカネ	1
17		SM-4020301-SC	SCREW M2X0.4 L=3		ナハコネジ M2 L=3	2
18	#01	A1121-103-A00	THROAT PLATE		マキスイヨ- ハリイタ	1
19		SS-6110480-SL	SCREW 11/64-40 L=4.3		ヒラネジ 11/64-40 L=4.3	2
20		A4106-102-000	UPPER KNIFE ARM GUIDE SHAFT		ウラメスウツメ カイトシク	1
21		SS-8120740-SP	SCREW 3/16-28 L=7		トメネジ 3/16-28 L=7	1
22		SS-6090520-SP	SCREW 9/64-40 L=5.0		ヒラネジ 9/64-40 L=5	1
23		A1131-103-000	CHIP PROTECTOR		ヌノクス ホ-シハハ	1
24		SS-5110810-SP	SCREW 11/64-40 L=8		トラネジ 11/64-40 L=8	2
25		A1108-102-000-B	SIDE COVER STOPPER		ヨコカバー-トメハハネ	1
26		SS-7110510-SP	SCREW 11/64-40 L=5		マルヒラネジ 11/64-40 L=5	1
27		A1103-102-000-9	FRAME BOTTOM PLATE		ソコイタ	1
28		SS-7150940-SP	SCREW 15/64-28 L=9		マルヒラネジ 15/64-28 L=9	2
29		A1129-102-000	RUBBER CUSHION		キユ-ハハ	1
30		A1113-102-000	LOOPER COVER HINGE PIN		ル-ハカハ- ヒンジシク	1
31		A1111-102-000	LOOPER COVER HINGE A		ル-ハカハ- ヒンジ A	1
32		SS-7110510-SP	SCREW 11/64-40 L=5		マルヒラネジ 11/64-40 L=5	2
33		A1130-102-000	LOOPER COVER SPRING		ル-ハカハ- ハネ	1
34		A1112-102-000	LOOPER COVER HINGE B		ル-ハカハ- ヒンジ B	1
35		A1110-103-00F	LOOPER COVER N		ル-ハカハ- N	1
36		A1115-102-000	CHIP GUARD STOPPER		ヌノクス カハ- コテイハネ	1
37		WP-0450000-SD	WASHER 4.5X8X0.5		ヒラツマカネ 4.5X8X0.5	1
38		SS-7110910-SP	SCREW		マルヒラネジ 11/64-40 L=8.5	2
39		A1114-103-000	CHIP GUARD COVER		ヌノクス カハ-	1
40		A1104-102-00A	SIDE COVER		ソクメンカバー	1
41		SS-7090910-SL	SCREW 9/64-40 L=8.5		マルヒラネジ 9/64-40 L=8.5	4
42		SS-7091410-SL	SCREW 9/64-40 L=13.5		マルヒラネジ 9/64-40 L=13.5	1

Note (注記) #01 ..... Special order part for hemming 巻縫い用特別注文部品

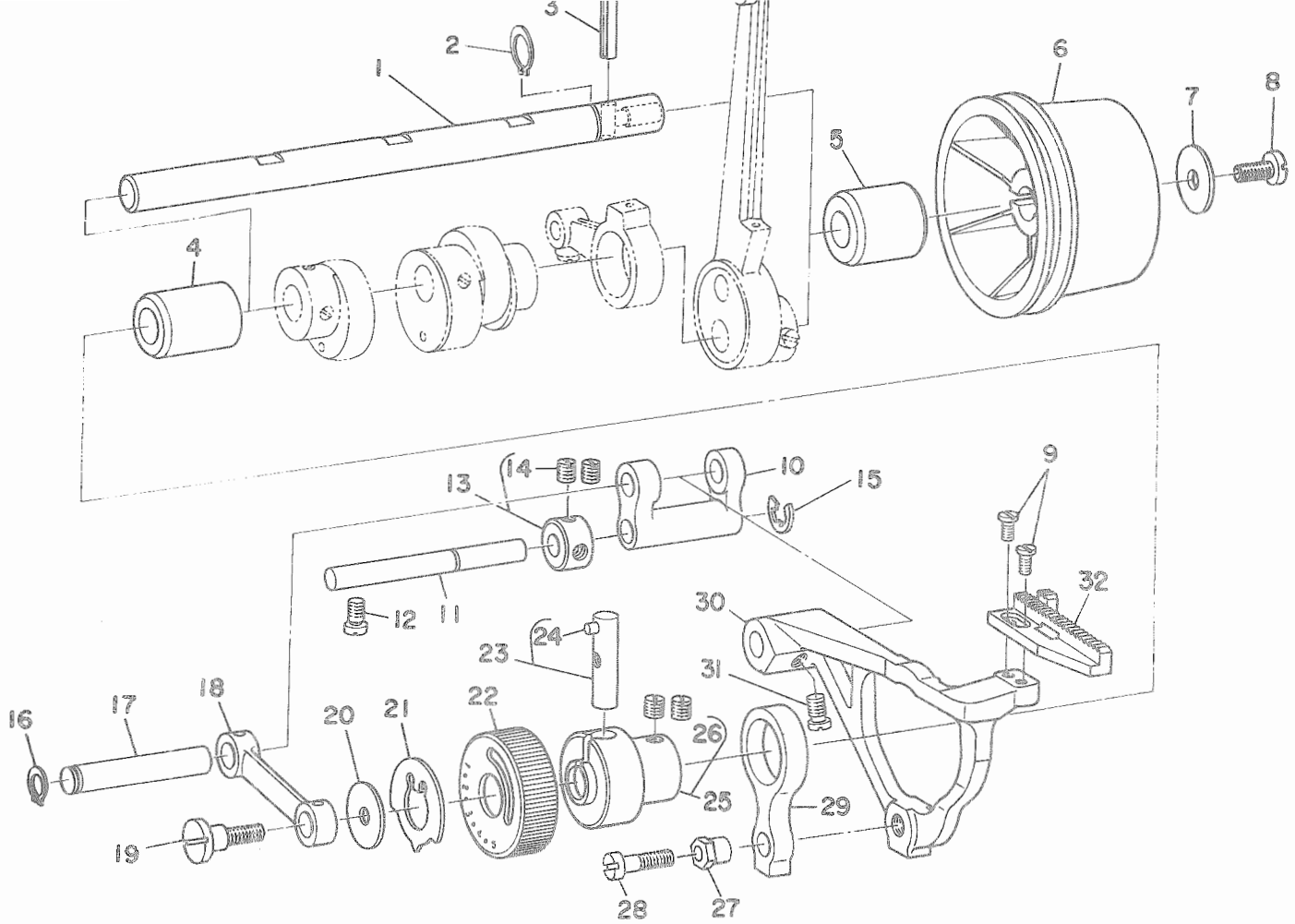

Ref. No.	Note 注記	Part No. 品番	Description	E. C. 変更年月	品名	Amt. Req. 数量
1		A1201-103-000	MAIN SHAFT		シユシツク	1
2		A1206-102-000	C RING		シユシツク エリツク	1
3		PS-0400222-K0	SPRING PIN		スプリングピン	1
4		A1204-102-000	MAIN SHAFT BUSHING, FRONT		シユシツク マシメタル	1
5		A1205-102-000	MAIN SHAFT BUSHING, REAR		シユシツク ウシロメタル	1
6		A1202-103-00F	HAND WHEEL N		ハシメ クルマ N	1
7		WP-0451016-SP	WASHER 4.5X20X1		ヒラケカネ 4.5X20X1	1
8		SS-6111140-SP	SCREW 11/64-40 L=11		ヒラネシ 11/64-40 L=11	1
9		SS-4080610-SP	SCREW 1/8-44 L=6.4		ナハネシ 1/8-44 L=6.4	2
10		A1610-102-000-A	FEED ROCKER ARM		スイハイオクリウテ	1
11		A1614-102-000	FEED ROCKER SHAFT		スイハイオクリシツク	1
12		SS-7120910-SP	SCREW 3/16-28 L=9		マルヒラネシ 3/16-28 L=9	1
13		CS-0720818-SP	THRUST COLLAR ASM. D=7.24 W=8		スラストウケ D=7.24 W=8 クミ	1
14		SM-8050310-SS	SCREW M5X0.8 L=3.4		トメネシ M5X0.8 L=3.4	(2)
15		RE-0600000-K0	SNAP RING 6		エカタメワ 6	1
16		RC-0650817-K0	RETAINING RING 6.5		Cカタメワ 6.5	1
17		A1611-102-000	FEED BAR SHAFT		オクリタメイ シツク	1
18		A1609-102-000	FEED ROCKER SHAFT CONNECTING ROD		スイハイオクリ ロツト	1
19		SD-0720701-SP	HINGE SCREW D=7.24 H=7		タメネシ D=7.24 H=7	1
20		WP-0451016-SP	WASHER 4.5X20X1		ヒラケカネ 4.5X20X1	1
21		A1606-102-000	STITCH DIAL STOPPER		タメイタル マワリトメ	1
22		A1605-102-000	STITCH DIAL		オクリチヨセツ タメイタル	1
23		A1604-102-0A0	FEED REGULATING PIN ASM.		オクリセイケツピン クミ	1
24		A1608-102-000	FEED REGULATING GUIDE PIN		ヒケツン カイトピン	(1)
25		A1601-102-0A0	FEED REGULATION CAM ASM.		オクリカム クミ	1
26		SS-8110510-SP	SCREW 11/64-40 L=5		トメネシ 11/64-40 L=5	(2)
27		A1603-102-000-A	FEED DRIVING LINK PIN		シヨウケオクリ リンクピン	1
28		SS-7091410-SP	SCREW 9/64-40 L=13.5		マルヒラネシ 9/64-40 L=13.5	1
29		A1602-102-000	FEED DRIVING LINK		シヨウケオクリ リンク	1
30		A1612-103-000-A	FEED BAR		オクリタメイ	1
31		SS-6120740-SP	SCREW 3/16-28 L=7		ヒラネシ 3/16-28 L=7	1
32		A1613-103-000	FEED DOG		オクリハ	1

### 3. KNIFE COMPONENTS メス関係

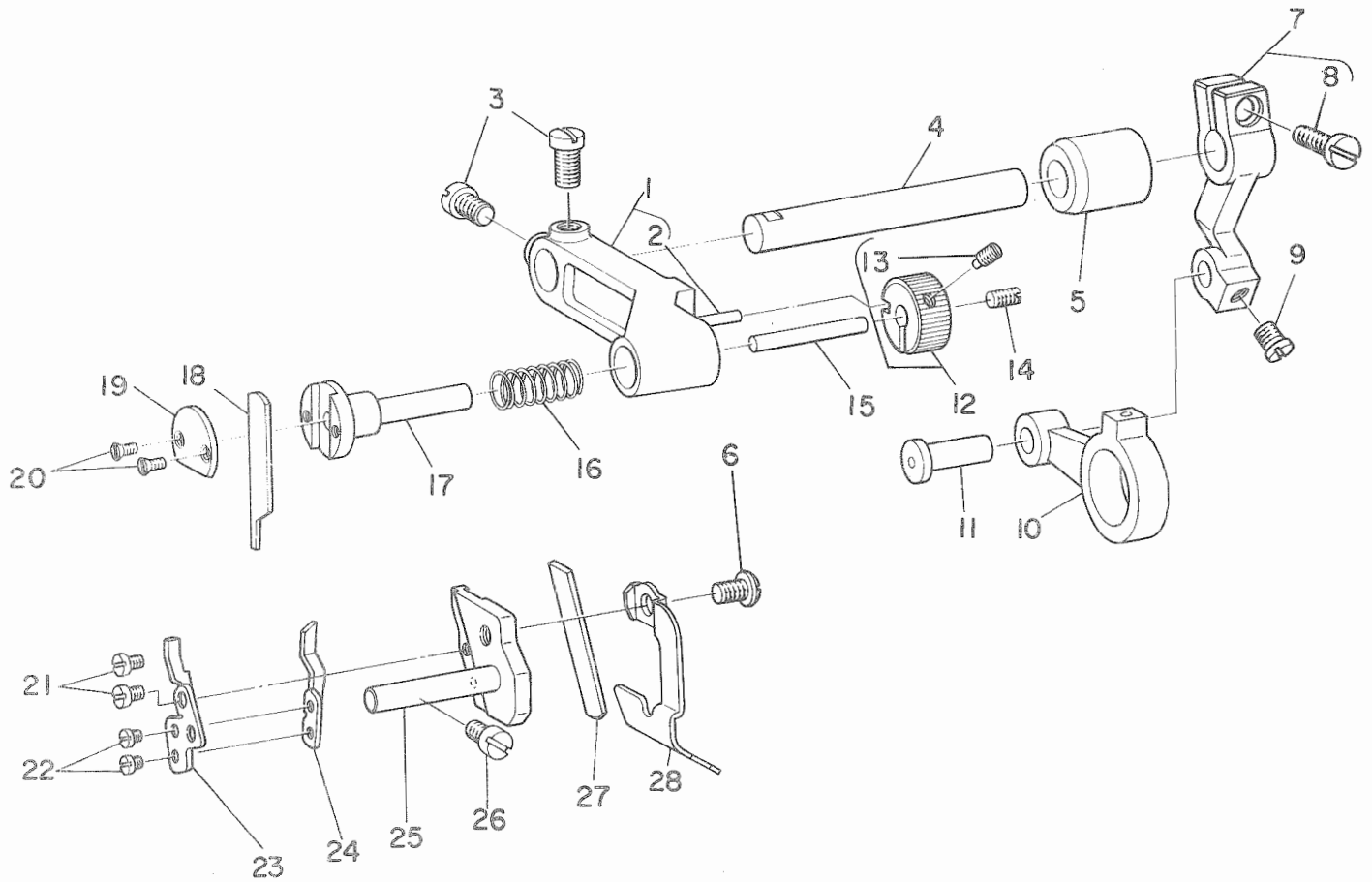

Ref. No.	Note 注記	Part No. 品番	Description	E. C. 変更年月	品名	Amt. Req. 数量
1		A4105-102-0A0	UPPER KNIFE DRIVING ARM ASM.		ウツメス ヨートウチン クミ	1
2		A1608-102-000	FEED REGULATING GUIDE PIN		ヒイケン カイトヒオン	(1)
3		SS-6150810-SP	SCREW 15/64-28 L=8		ヒラネジ 15/64-28 L=8	2
4		A4103-102-000	KNIFE DRIVING SHAFT		メス クトウシヤク	1
5		A4104-102-000	KNIFE DRIVING SHAFT BUSHING		メス クトウシヤクメタル	1
6		SS-5110810-SP	SCREW 11/64-40 L=8		トラスネジ 11/64-40 L=8	1
7		A4102-103-0A0	UPPER KNIFE DRIVING ARM ASM.		ウツメス クトウチン クミ	1
8		SS-6121210-SP	SCREW 3/16-28 L=12		ヒラネジ 3/16-28 L=9	(1)
9		SS-6120740-SP	SCREW 3/16-28 L=7		ヒラネジ 3/16-28 L=7	1
10		A4101-103-000	UPPER KNIFE CRANK ROD		ウツメスロツト	1
11		A1403-102-000	CONNECTING PIN		レンケツ ヒオン	1
12		A4109-102-0A0	UPPER KNIFE STOPPER ASM.		ウツメス ストツハク クミ	1
13		SS-8090650-TP	SCREW 9/64-40 L=5.5		トメネジ 9/64-40 L=5.5	(1)
14		SS-8090710-SP	SCREW 9/64-40 L=7.0		トメネジ 9/64-40 L=7	1
15		A4108-102-000	UPPER KNIFE PRESSER PIN		メスオウエイヒオン	1
16		A4111-102-000	UPPER KNIFE PRESSER SPRING		メスオウエイバネ	1
17		A4107-102-000	UPPER KNIFE HOLDER		ウツメスホルダウシヤク	1
18		B4108-352-000	CEMENTED CARBIDE UPPER KNIFE		チヨウゴウ ウツメス	1
19		A4110-102-000	UPPER KNIFE PRESSER PLATE		メスオウエイタ	1
20		SS-2060510-SP	SCREW 3/32-56 L=4.5		マルツラネジ 3/32-56 L=4.5	2
21		SS-7080510-TP	SCREW 1/8-44 L=4.5		マルヒラネジ 1/8-44 L=4.5	2
22		SS-6060340-SP	SCREW 3/32-56 L=2.5		ヒラネジ 3/32-56 L=2.5	2
23		A4116-103-A00	NEEDLE GUARD A (N)		ハリウケ A (N)	1
24		A4117-103-000	NEEDLE GUARD B		ハリウケ B	1
25		A4112-103-A00	LOWER KNIFE HOLDER		シタメスホルダ USA	1
26		SS-7120910-SP	SCREW 3/16-28 L=9		マルヒラネジ 3/16-28 L=9	1
27		A4113-102-000	LOWER KNIFE		シタメス	1
28		A4115-103-000	LOWER KNIFE PRESSER PLATE		シタメスオウエイタ	1

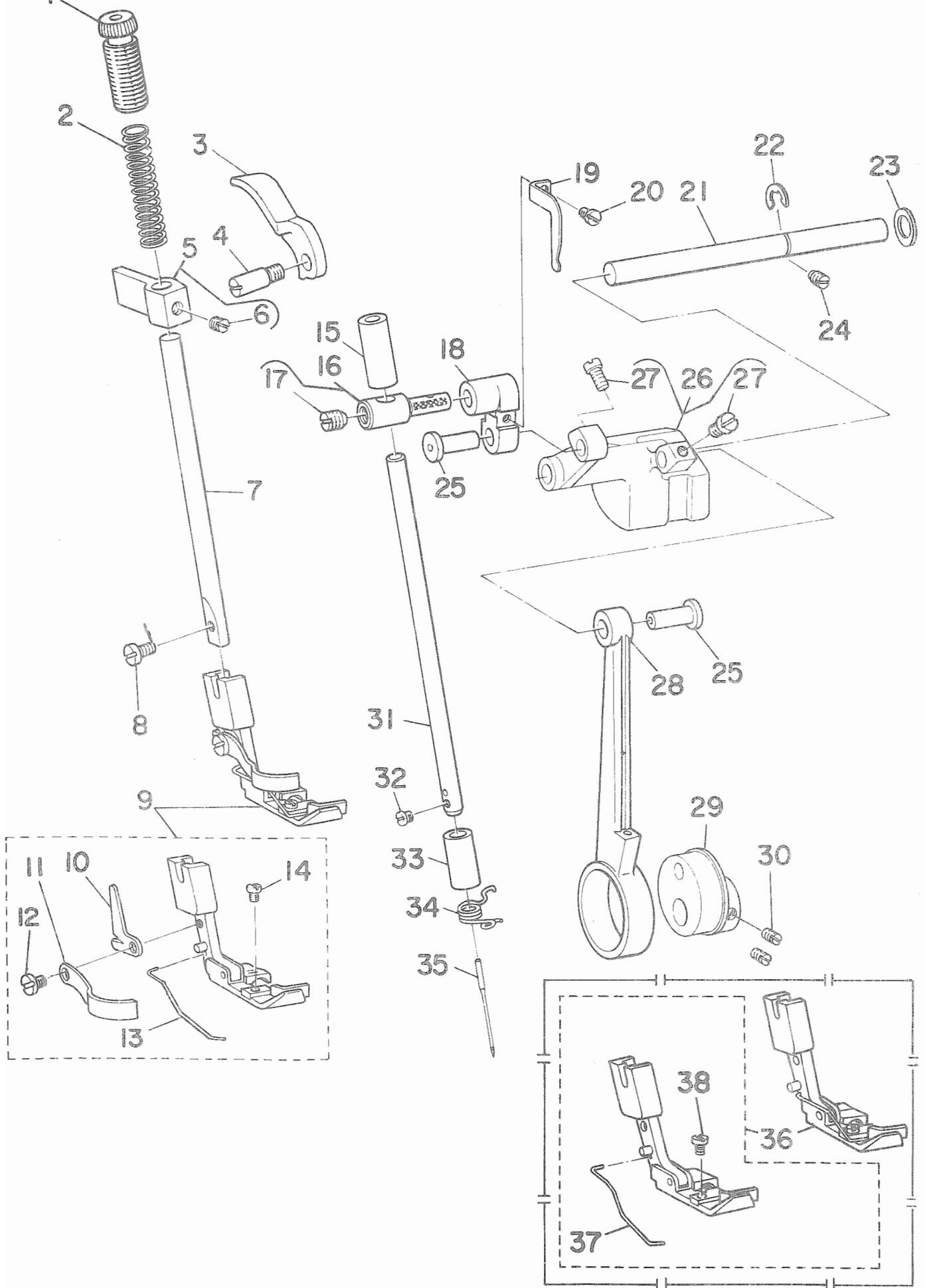



Ref. No.	Note 注記	Part No. 品番	Description	E. C. 変更年月	品名	Amt. Req. 数量
1		A1509-001-000	PRESSER SPRING REGULATOR SCREW		オウエ チヨ-ピツネシ	1
2		A1506-102-000	PRESSER SPRING.		オウエハネ	1
3		A1508-102-000	PRESSER FOOT LIFTING LEVER		オウエアケム レハム-	1
4		B1508-352-000	STOPPER SCREW		ストツハ-ネシ	1
5		A1507-102-0A0	PRESSER BAR GUIDE BRACKET ASM.		オウエホムウ アンナイ クミ	1
6		SS-8110320-SP	SCREW 11/64-40 L= 3.2		トメネシ 11/64-40 L=3.2	(1)
7		A1505-102-000	PRESSER BAR		オウエホム-	1
8		SS-7090710-SP	SCREW 9/64-40 L= 6.8		マルヒラネシ 9/64-40 L=6.8	1
9		A1501-103-0B0-A	PRESSER FOOT ASM.		オウエ クミ USA	1
10		A1504-102-000	THREAD TRIMMER		イトキリハム	(1)
11		A1510-102-000	FINGER PROTECTOR		ハリカ-トキイ	(1)
12		SS-6090520-SP	SCREW 9/64-40 L= 5.0		ヒラネシ 9/64-40 L=5	(2)
13		A1503-102-000	PRESSER SPRING, FRONT		マエ オウエハネ	(1)
14		SS-6060410-TP	SCREW 3/32-56 L= 3.5		ヒラネシ 3/32-56 L=3.5	(1)
15		A1406-202-000	NEEDLE BAR BUSHING		ハリホ-メタル	1
16		A1409-102-0A0	NEEDLE BAR CONNECTION ASM.		ハリホ-タキ クミ	1
17		SS-8150750-SP	SCREW 15/64-28 L=7		トメネシ 15/64-28 L=7	(1)
18		A1408-104-000	NEEDLE BAR LINK		ハリホ-リンク	1
19		A1412-103-000	NEEDLE THREAD TAKE-UP LEVER		ハリイト テンヒム	1
20		SS-6090620-SP	SCREW 9/64-40 L=6		ヒラネシ 9/64-40 L=6	1
21		A1405-102-000	NEEDLE BAR DRIVING SHAFT		ハリホ-クム-シツク	1
22		RE-0700000-K0	SNAP RING 7		Eカムタメワ 7	1
23		WP-0820516-SP	WASHER 11.6X8.2X0.6		ヒラグカメネ 8.2X11.6X0.6	1
24		SS-8120740-SP	SCREW 3/16-28 L=7		トメネシ 3/16-28 L=7	1
25		A1403-102-000	CONNECTING PIN		レンケツ ヒオン	2
26		A1404-102-0A0	NEEDLE BAR CRANK ASM.		ハリホ-クランク クミ	1
27		SS-6110710-TP	SCREW 11/64-40 L= 6.5		ヒラネシ 11/64-40 L=6.5	(2)
28		A1402-102-000	NEEDLE BAR CRANK ROD		ハリホ-クランクロツト	1
29		A1401-103-0A0	NEEDLE BAR ECCENTRIC CAM ASM.		ハリホ-クム-カム	1
30		SS-8110510-SP	SCREW 11/64-40 L=5		トメネシ 11/64-40 L=5	(2)
31		A1410-102-000	NEEDLE BAR		ハリホ-	1
32		SS-4080320-TP	SCREW 1/8-44 L=3.4		チハネシ 1/8-44 L=3.4	1
33		A1407-102-000	NEEDLE BAR BUSHING, LOWER		ハリホ-シタメタル	1
34		A1411-103-000	NEEDLE BAR THREAD GUIDE		ハリホ-イトアンナイ	1
35		MBL-100B1100	NEEDLE BLX1 #11		ハリ BLX1 #11	1
36	#01	A1501-102-AA0	PRESSER FOOT ASM.		マキヌイヨ-オウエ クミ	1
37	#01	A1503-102-000	PRESSER SPRING, FRONT		マエ オウエハネ	(1)
38	#01	SS-6060410-TP	SCREW 3/32-56 L= 3.5		ヒラネシ 3/32-56 L=3.5	(1)

Note (注記) #01 ..... Special order part for hemming 巻縫い用特別注文部品

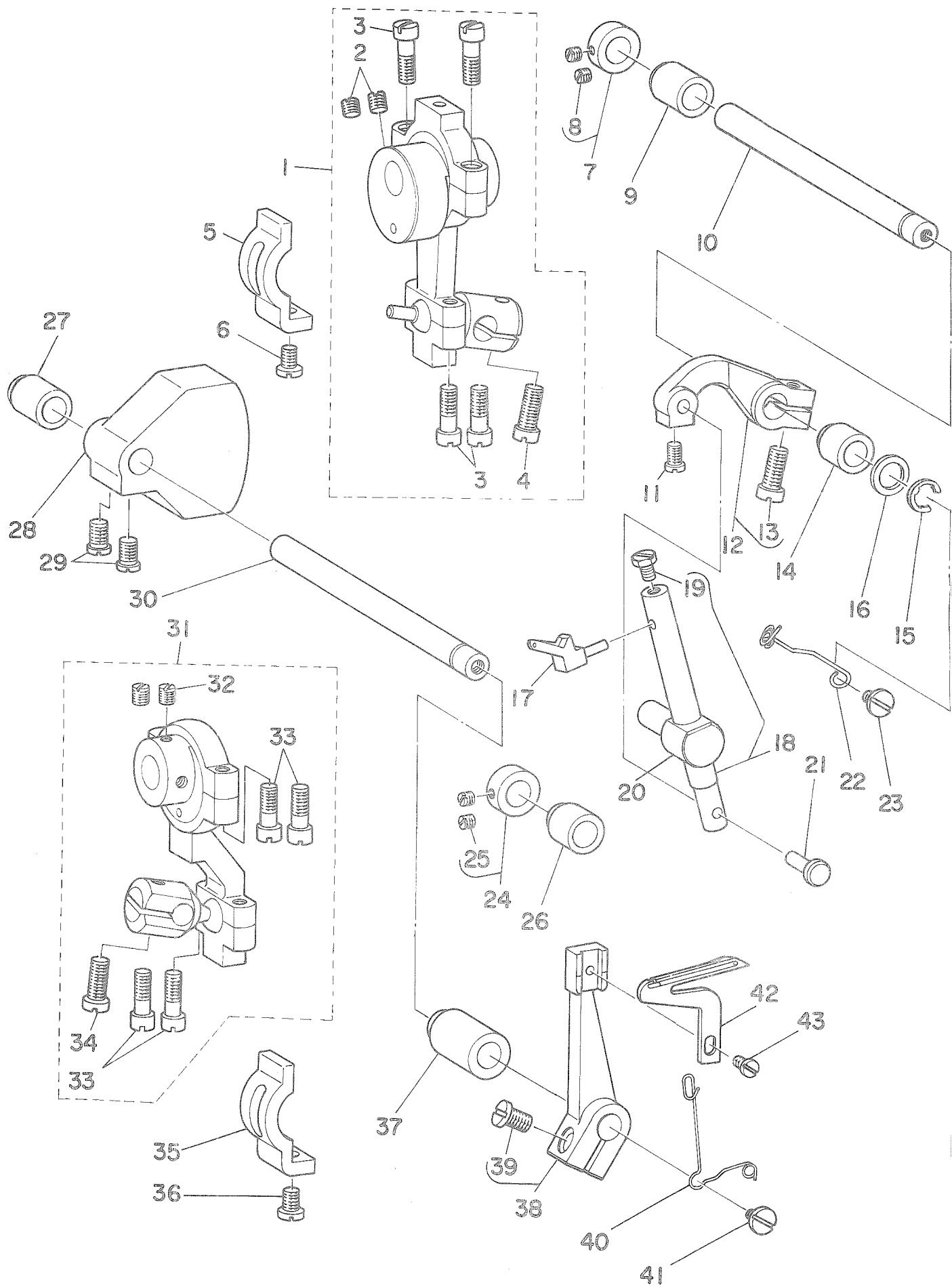

Ref. No.	Note 注記	Part No. 品番	Description	E. C. 変更年月	品名	Amt. Req. 数量
1		A2502-103-080	UPPER LOOPER ROD ASM.		ウフル-ハ°ロツト™ クミ	1
2		SS-8110510-SP	SCREW 11/64-40 L=5		トメネジ™ 11/64-40 L=5	(2)
3		SS-7111310-SP	SCREW 11/64-40 L=12.8		マルヒラネジ™ 11/64-40 L=12.8	(4)
4		SS-6121210-SP	SCREW 3/16-28 L=12		ヒラネジ™ 3/16-28 L=9	(1)
5		A2503-202-000	VIBRATION STOPPER		フレト™	1
6		SS-7090850-SP	SCREW 9/64-40 L=8		マルヒラネジ™ 9/64-40 L=8	1
7		CS-079061C-SP	THRUST COLLAR ASM.		スラストウケ クミ	1
8		SS-8090410-SP	SCREW 9/64-40 L=3.5		トメネジ™ 9/64-40 L=3.5	(2)
9		A2506-202-000	LOOPER SHAFT BUSHING		ル-ハ°シ™クメタル	1
10		A2504-103-000	LOOPER SHAFT		ル-ハ°シ™ク	1
11		SS-6090620-SP	SCREW 9/64-40 L=6		ヒラネジ™ 9/64-40 L=6	1
12		A2508-103-000	UPPER LOOPER SHAFT DRIVING ARM		ウフル-ハ°ウテ™	1
13		SS-6121210-SP	SCREW 3/16-28 L=12		ヒラネジ™ 3/16-28 L=9	(1)
14		A2505-103-000	UPPER LOOPER SHAFT BUSHING, FRONT		ウフル-ハ°シ™ク マイメタル	1
15		WP-0820516-SP	WASHER 11.6X8.2X0.6		ヒラウ™カ™ネ 8.2X11.6X0.6	1
16		RE-0700000-KO	SNAP RING 7		Eカ™タ™メウ 7	1
17		A2512-103-000	UPPER LOOPER		ウフル-ハ°	1
18		A2509-103-0A0	UPPER LOOPER SLIDE STUD ASM.		ウフル-ハ° スライト™シ™ク クミ	1
19		SS-7090520-TP	SCREW 9/64-40 L=4.5		マルヒラネジ™ 9/64-40 L=4.5	(1)
20		A2511-103-000	SLIDING SHAFT GUIDE		ウフル-ハ°カ™イト™	1
21		A2510-103-000	PIN		ウフル-ハ°ウテ™ E°ン	1
22		A2519-203-000	UPPER LOOPER THREAD TAKE-UP		ウフル-ハ° テンヒ™ン	1
23		SS-6090630-SP	SCREW 9/64-40 L=6		ヒラネジ™ 9/64-40 L=6	1
24		CS-079061C-SP	THRUST COLLAR ASM.		スラストウケ クミ	1
25		SS-8090410-SP	SCREW 9/64-40 L=3.5		トメネジ™ 9/64-40 L=3.5	(2)
26		A2505-103-000	UPPER LOOPER SHAFT BUSHING, FRONT		ウフル-ハ°シ™ク マイメタル	1
27		A2506-202-000	LOOPER SHAFT BUSHING		ル-ハ°シ™クメタル	1
28		A2518-103-000	COUNTERWEIGHT		シタル-ハ°シ™ク ツリアイネリ	1
29		SS-6120740-SP	SCREW 3/16-28 L=7		ヒラネジ™ 3/16-28 L=7	2
30		A2504-103-000	LOOPER SHAFT		ル-ハ°シ™ク	1
31		A2514-103-080	LOWER LOOPER ROD ASM.		シタル-ハ°ロツト™ クミ	1
32		SS-8110510-SP	SCREW 11/64-40 L=5		トメネジ™ 11/64-40 L=5	(2)
33		SS-7111310-SP	SCREW 11/64-40 L=12.8		マルヒラネジ™ 11/64-40 L=12.8	(4)
34		SS-6121210-SP	SCREW 3/16-28 L=12		ヒラネジ™ 3/16-28 L=9	(1)
35		A2503-202-000	VIBRATION STOPPER		フレト™	1
36		SS-7090850-SP	SCREW 9/64-40 L=8		マルヒラネジ™ 9/64-40 L=8	1
37		A2507-103-000	LOWER LOOPER SHAFT BUSHING, FRONT		シタル-ハ°シ™ク マイメタル	1
38		A2516-103-0A0	LOWER LOOPER HOLDER ASM.		シタル-ハ° シ™ウテ™ クミ	1
39		SS-6121210-SP	SCREW 3/16-28 L=12		ヒラネジ™ 3/16-28 L=9	(1)
40		A2520-203-000	LOWER LOOPER THREAD TAKE-UP		シタル-ハ° テンヒ™ン	1
41		SS-6090630-SP	SCREW 9/64-40 L=6		ヒラネジ™ 9/64-40 L=6	1
42		A2517-103-000	LOWER LOOPER		シタル-ハ°	1
43		SS-6090610-SP	SCREW 1/8-44 L=6		ヒラネジ™	1

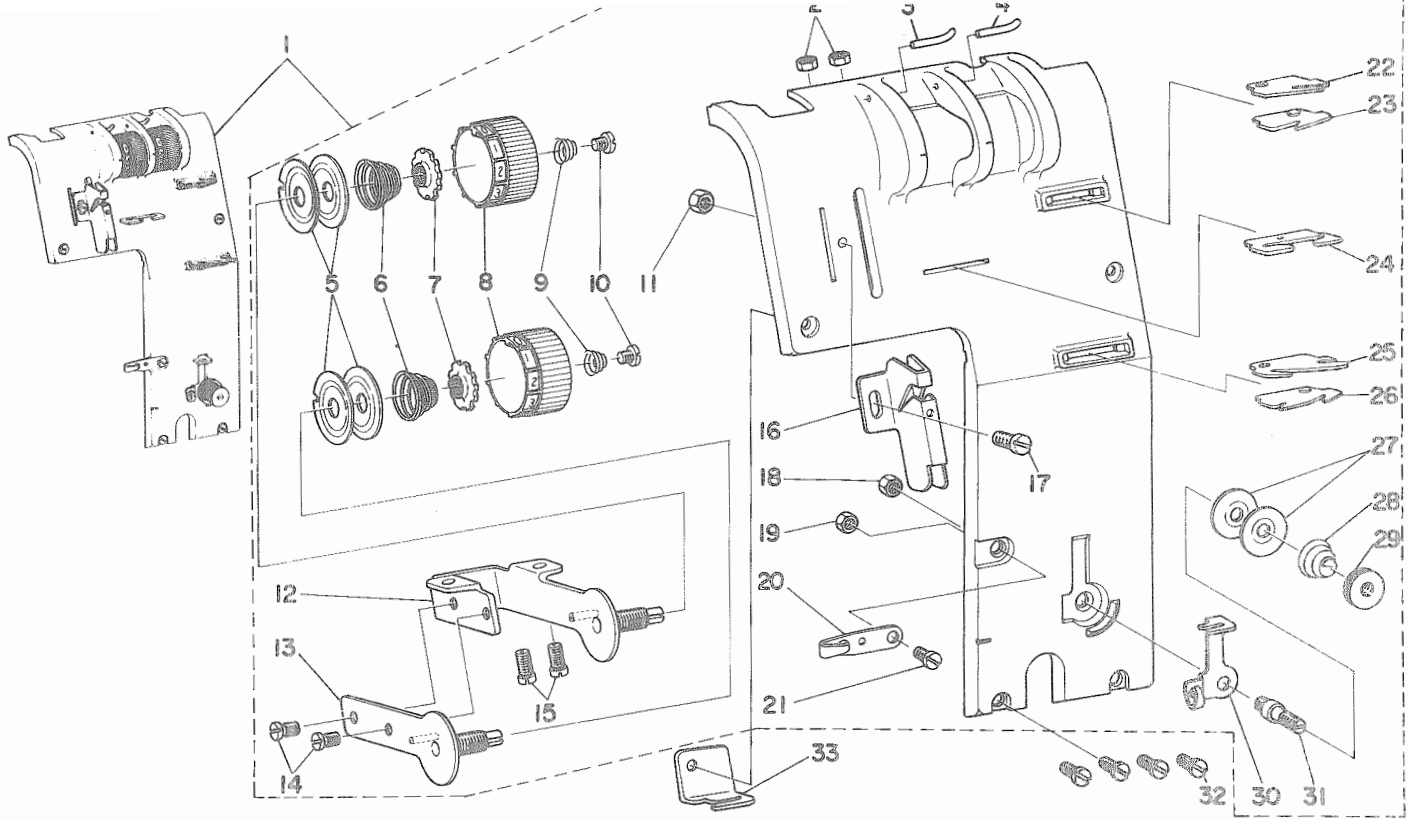

Ref. No.	Note 注記	Part No. 品番	Description	E. C. 変更年月	品名	Amt. Req. 数量
1		A3101-103-DAF	FRONT COVER ASM. N		シヨウメンカバー クミ N	1
2		NS-6110310-SP	NUT 11/64-40		ロツカクナツト 11/64-40	(2)
3		A3503-104-COF	TENSION THREAD GUIDE		イトチヨウシイトアンナイ USA	(1)
4		A3503-102-COF	TENSION THREAD GUIDE		イトチヨウシイトアンナイ USA	(1)
5		B3126-352-000	TENSION DISC		イトチヨ-シ ヌラ	(4)
6		A3108-103-000	NEEDLE THREAD TENSION SPRING		ウツイトチヨ-シハネ	(2)
7		A3134-755-000	NEEDLE THREAD TENSION NUT		イトチヨ-シ ナツト	(2)
8		A3107-103-000	NEEDLE THREAD TENSION KNOB		ウツイトチヨ-シ ツマミ	(2)
9		B3149-123-B00	CHAIN LOOPER THREAD TENSION SPRING		イトアンナイツツラ ハネ	(2)
10		SS-6090520-SP	SCREW 9/64-40 L= 5.0		ヒラネジ 9/64-40 L=5	(2)
11		NS-6090310-SP	NUT 9/64-40		ロツカクナツト 9/64-40	(1)
12		A3505-103-080	THREAD TENSION POST A ASM.		イトチヨ-シホ-クイ A クミ	(1)
13		A3506-103-0A0	THREAD TENSION POST B ASM.		イトチヨ-シホ-クイ B クミ	(1)
14		SS-7110540-SP	SCREW 11/64-40 L=5		マルヒラネジ 11/64-40 L= 5	(2)
15		SS-7110810-SP	SCREW 11/64-40 L= 8.0		マルヒラネジ 11/64-40 L=8	(2)
16		A3103-103-COF	NEEDLE THREAD GUIDE B		ハリイト アンナイ B USA	(1)
17		SS-7090710-SL	SCREW 9/64-40 L=6.8		マルヒラネジ 9/64-40 L=6.8	(1)
18		NS-6110310-SP	NUT 11/64-40		ロツカクナツト 11/64-40	(1)
19		NS-6090310-SP	NUT 9/64-40		ロツカクナツト 9/64-40	(1)
20		A3105-103-00F	UPPER LOOPER THREAD GUIDE		ウツル-ハ° イトアンナイUSA	(1)
21		SS-7090710-SL	SCREW 9/64-40 L=6.8		マルヒラネジ 9/64-40 L=6.8	(1)
22		A3504-102-00F	LOOPER THREAD GUIDE		ル-ハ° イトアンナイUSA	(1)
23		A3504-102-000	LOOPER THREAD GUIDE		ル-ハ° イトアンナイ	(1)
24		A3102-103-00F	NEEDLE THREAD GUIDE A		ハリイト アンナイ A USA	(1)
25		A3504-103-00F	LOOPER THREAD GUIDE		ル-ハ° イトアンナイ USA	(1)
26		A3504-104-000	LOOPER THREAD GUIDE		ル-ハ° イトアンナイ	(1)
27		B3214-047-000	BOBBIN WINDER TENSION DISC		イトチヨ-シ ヌラ	(2)
28		B3218-232-000	BOBBIN WINDER TENSION SPRING		イトチヨ-シ ハネ	(1)
29		B3216-047-000	BOBBIN WINDER TENSION NUT		イトチヨ-シ ナツト	(1)
30		A3106-103-00F	LOWER LOOPER THREAD GUIDE		シタル-ハ° イトアンナイUSA	(1)
31		B3219-232-000	BOBBIN WINDER TENSION POST		イトマキ イトチヨ-シホ-	(1)
32		SS-7090910-SL	SCREW 9/64-40 L=8.5		マルヒラネジ 9/64-40 L=8.5	4
33		A3104-103-00F	NEEDLE THREAD GUIDE C (N)		ハリイトアンナイ C (N)	1

# 7. MOTOR COMPONENTS

モーター関係

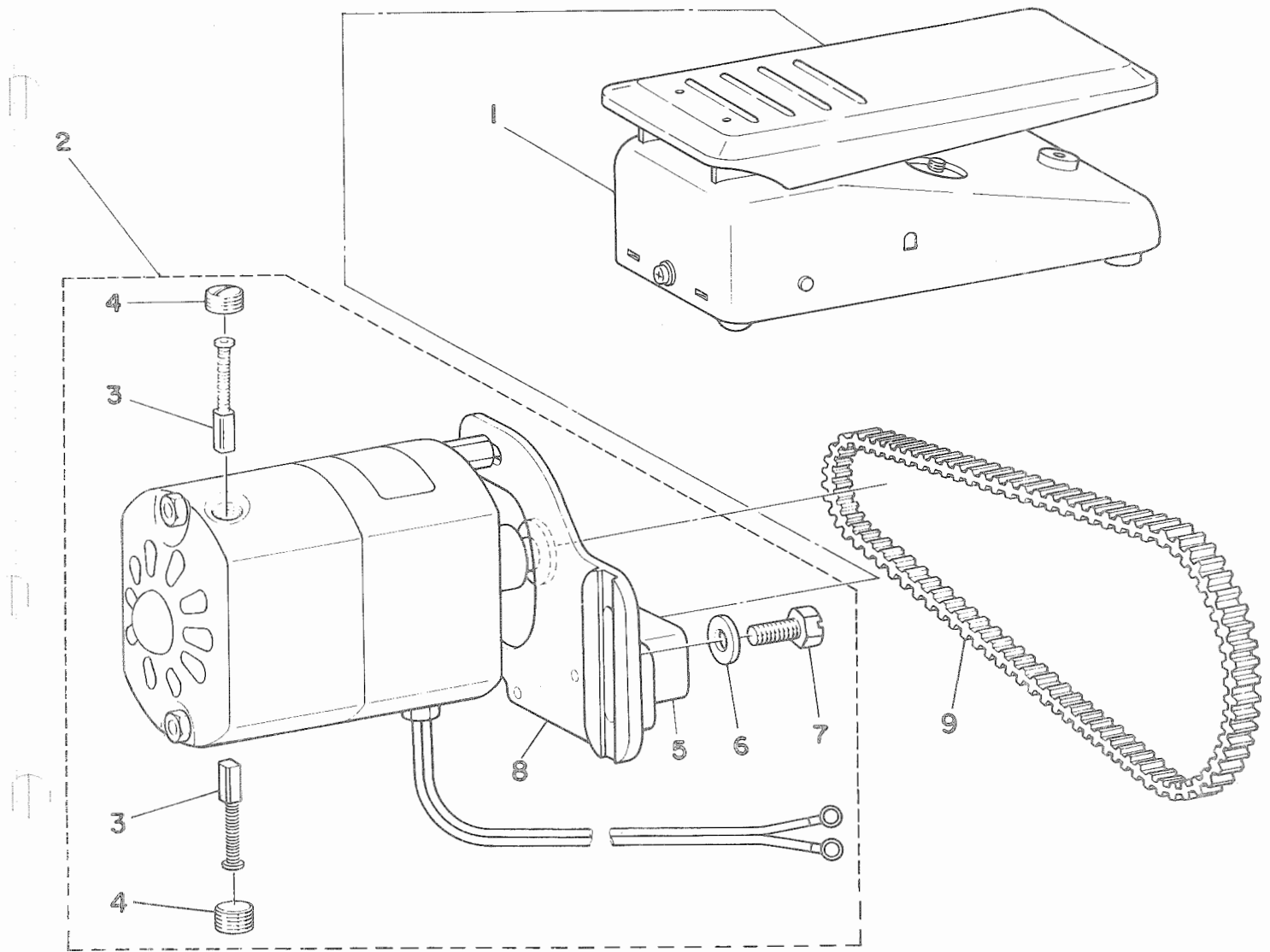

Ref. No.	Note 注記	Part No. 品番	Description	E. C. 変更年月	品名	Amt. Req. 数量
1		MSA-1722F3M0	CONTROLLER ASM.		モータ	1
2		MSA-172202M0	MOTOR ASM.		モータ クミ USA	1
3		MSA-01071M06	CARBON BRUSH		カーボンブラシ	(2)
4		MSA-01071M07	CARBON BRUSH CAP		ブラシキャップ	(2)
5		A6001-102-J00-A	TERMINAL NO.32 200/230V		ターミナル	(1)
6		WP-0751616-SC	WASHER 7.5X14X1.6		ヒラシカネ 7.5X14X1.6	(1)
7		SS-9181950-SC	BOLT 9/32 L=19		ロツカクネルト 9/32-20 L=19	(1)
8		A6003-102-000	MOTOR BRACKET		モータ フラケット	(1)
9		A7108-001-000	BELT		ベルト	1

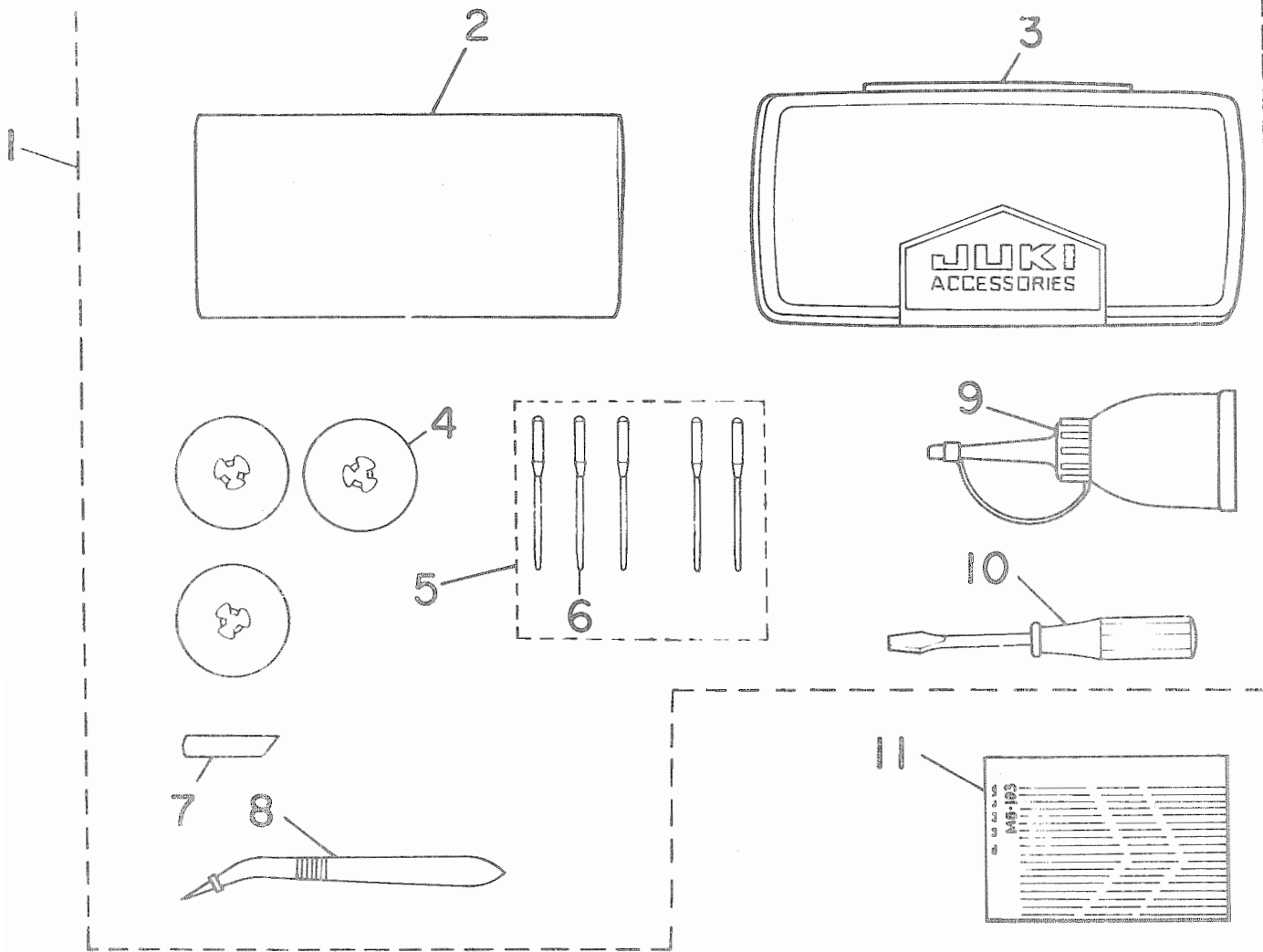

Ref. No.	Note 注記	Part No. 品番	Description	E. C. 変更年月	品名	Amt. Req. 数量
1		A9101-103-F80	ACCESSORY BOX ASM.		フソクフヒンバコ クミ	1
2		A9102-102-000	VINYL COVER		トーフ ヴィニールカバー	(1)
3		A9101-001-80A	ACCESSORY BOX		フソクフヒンバコ	(1)
4		A1114-957-800	SPOOL HOLDER DISC		イトマキ アチャク	(3)
5		MBL-100B1105	NEEDLE ASM.		ハリ BLX1 #11	(1)
6		MBL-100B1100	NEEDLE BLX1 #11		ハリ BLX1 #11	(5)
7		A4113-102-000	LOWER KNIFE		シタメス	(1)
8		B9204-352-000	TWEEZERS		ピンセット	(1)
9		A9104-102-0A0	OILER WITH OIL ASM		アブラサシ クミ	(1)
10		A9103-102-000	SCREW DRIVER, LARGE		ドライバー (テスター)	(1)
11		AE-1030S0E-0B	INSTRUCTION BOOK		シヨクセツメイシヨ USA	1

NUMERICAL INDEX OF PARTS

索引

Part No. 品番	Page 頁	Ref. No.	Part No. 品番	Page 頁	Ref. No.	Part No. 品番	Page 頁	Ref. No.	Part No. 品番	Page 頁	Ref. No.
AE-1030S08-08	11	11	A2506-202-000	8	9	MSA-1722F3M0	10	1	SS-8110320-SP	6	6
A1103-102-000-B	2	27	A2506-202-000	8	27	MSA-172202M0	10	2	SS-8110510-SP	3	26
A1104-102-00A	2	40	A2507-103-000	8	37				SS-8110510C-SP	6	30
A1105-102-00A	2	7	A2508-103-000	8	12				SS-8110510-SP	8	2
A1106-103-00F	2	11	A2509-103-0A0	8	18	NS-6090310-SP	2	9	SS-8110510-SP	8	32
A1107-102-000	2	12	A2510-103-000	8	21	NS-6090310-SP	9	11	SS-8120740-SP	2	21
A1108-102-000-B	2	25	A2511-103-000	8	20	NS-6090310-SP	9	19	SS-8120740-SP	6	24
A1110-103-00F	2	35	A2512-103-000	8	17	NS-6110310-SP	9	2	SS-8150750-SP	6	17
A1111-102-000	2	31	A2514-103-0B0	8	31	NS-6110310-SP	9	18	SS-9181950-SC	10	7
A1112-102-000	2	34	A2516-103-0A0	8	38						
A1113-102-000	2	30	A2517-103-000	8	42						
A1114-103-000	2	39	A2518-103-000	8	28	PS-0400222-K0	3	3	WP-0450000-SD	2	37
A1114-957-800	11	4	A2519-203-000	8	22				WP-0451016-SP	3	7
A1115-102-000	2	36	A2520-203-000	8	40				WP-0451016-SP	3	20
A1116-104-0AF	2	5	A3101-103-0AF	9	1	RC-0650811-K0	3	16	WP-0751616-SC	10	6
A1120-202-000	2	2	A3102-103-00F	9	24	RE-0600000-K0	3	15	WP-0820516-SP	6	23
A1121-103-A00	2	18	A3103-103-00F	9	16	RE-0700000-K0	6	22	WP-0820516-SP	8	15
A1121-103-B00	2	13	A3104-103-00F	9	33	RE-0700000-K0	8	16			
A1123-102-000	2	1	A3105-103-00F	9	20						
A1124-102-000	2	3	A3106-103-00F	9	30						
A1127-104-000	2	4	A3107-103-000	9	8	SD-0720701-SP	3	19			
A1129-102-000	2	29	A3108-103-000	9	6	SM-4020301-SC	2	17			
A1130-102-000	2	33	A3134-755-000	9	7	SM-8050310-SS	3	14			
A1130-203-000	2	14	A3503-102-00F	9	4	SS-2060510-SP	4	20			
A1131-103-000	2	23	A3503-104-00F	9	3	SS-4080320-TP	6	32			
A1131-203-000	2	15	A3504-102-00F	9	22	SS-4080610-SP	3	9			
A1132-203-000	2	16	A3504-102-000	9	23	SS-5110810-SP	2	24			
A1201-103-000	3	1	A3504-103-00F	9	25	SS-5110810-SP	4	6			
A1202-103-00F	3	6	A3504-104-000	9	26	SS-6060340-SP	4	22			
A1204-102-000	3	4	A3505-103-0B0	9	12	SS-6060410-TP	6	14			
A1205-102-000	3	5	A3506-103-0A0	9	13	SS-6060410-TP	6	38			
A1206-102-000	3	2	A4101-103-000	4	10	SS-6080610-SP	8	43			
A1401-103-0A0	6	29	A4102-103-0A0	4	7	SS-6090520-SP	2	22			
A1402-102-000	6	20	A4103-102-000	4	4	SS-6090520-SP	6	12			
A1403-102-000	4	11	A4104-102-000	4	5	SS-6090520-SP	9	10			
A1403-102-000	6	25	A4105-102-0A0	4	1	SS-6090620-SP	6	20			
A1404-102-0A0	6	26	A4106-102-000	2	20	SS-6090620-SP	3	11			
A1405-102-000	6	21	A4107-102-000	4	17	SS-6090630-SP	8	23			
A1406-202-000	6	15	A4108-102-000	4	15	SS-6090630-SP	8	41			
A1407-102-000	6	33	A4109-102-0A0	4	12	SS-6110480-SL	2	19			
A1408-104-000	6	18	A4110-102-000	4	19	SS-6110710-TP	6	27			
A1409-102-0A0	6	16	A4111-102-000	4	16	SS-6111140-SP	3	8			
A1410-102-000	6	31	A4112-103-A00	4	25	SS-6120740-SP	3	31			
A1411-103-000	6	34	A4113-102-000	4	27	SS-6120740-SP	4	9			
A1412-103-000	6	19	A4113-102-000	11	7	SS-6120740-SP	9	29			
A1501-102-AA0	6	36	A4115-103-000	4	28	SS-6121210-SP	2	5			
A1501-103-0B0-A	6	9	A4116-103-A00	4	23	SS-6121210-SP	2	8			
A1503-102-000	6	13	A4117-103-000	4	24	SS-6121210-SP	4	8			
A1503-102-000	6	37	A6001-102-J00-A	10	5	SS-6121210-SP	8	4			
A1504-102-000	6	10	A6003-102-000	10	8	SS-6121210-SP	8	13			
A1505-102-000	6	7	A7108-001-000	10	9	SS-6121210-SP	8	34			
A1506-102-000	6	2	A9101-001-80A	11	3	SS-6121210-SP	3	39			
A1507-102-0A0	6	5	A9101-103-FB0	11	1	SS-6150810-SP	4	3			
A1508-102-000	6	3	A9102-102-000	11	2	SS-7080510-TP	4	21			
A1509-001-000	6	1	A9103-102-000	11	10	SS-7090520-TP	8	19			
A1510-102-000	6	11	A9104-102-0A0	11	9	SS-7090710-SL	2	10			
A1601-102-0A0	3	25				SS-7090710-SL	9	17			
A1602-102-000	3	29	B1508-352-000	6	4	SS-7090710-SL	9	21			
A1603-102-000-A	3	27	B3126-352-000	9	5	SS-7090850-SP	8	6			
A1604-102-0A0	3	23	B3149-123-800	9	9	SS-7090850-SP	8	36			
A1605-102-000	3	22	B3214-047-000	9	27	SS-7090910-SL	2	41			
A1606-102-000	3	21	B3216-047-000	9	29	SS-7090910-SL	9	32			
A1608-102-000	3	24	B3218-232-000	9	28	SS-7091410-SL	2	42			
A1608-102-000	3	24	B3219-232-000	9	31	SS-7091410-SL	3	28			
A1608-102-000	4	2	B4108-352-000	4	18	SS-7110510-SP	2	26			
A1609-102-000	3	18	B9204-352-000	11	8	SS-7110510-SP	2	32			
A1610-102-000-A	3	10				SS-7110540-SP	9	14			
A1611-102-000	3	17				SS-7110810-SP	9	15			
A1612-103-000-A	3	30	CS-0720818-SP	3	13	SS-7110910-SP	2	38			
A1613-103-000	3	32	CS-079061C-SP	8	7	SS-7111310-SP	3	3			
A1614-102-000	3	11	CS-079061C-SP	8	24	SS-7111310-SP	8	33			
A2502-103-0B0	8	1				SS-7120910-SP	3	12			
A2503-202-000	8	5				SS-7120910-SP	4	26			
A2503-202-000	8	35	MBL-100B1100	6	35	SS-7150940-SP	2	28			
A2504-103-000	8	10	MBL-100B1100	11	6	SS-8090410-SP	8	8			
A2504-103-000	8	30	MBL-100B1105	11	5	SS-8090410-SP	8	25			
A2505-103-000	8	14	MSA-01071M06	10	3	SS-8090650-TP	4	13			
A2505-103-000	8	26	MSA-01071M07	10	4	SS-8090710-SP	4	14			

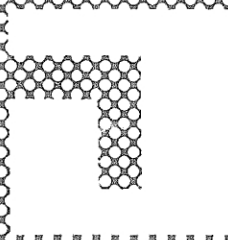

  
**東京重機工業株式会社**

〒182  
本社・営業本部 東京都調布市国領町8の2の1 TEL(480)1113(代)

Printed in Japan(T)