

1

1051

1053

Teileliste

Parts list

Liste de pièces

Lista de piezas

1181

1183

Diese Teileliste hat für Maschinen ab nachfolgender
Seriennummer Gültigkeit:

This parts list applies to machines from the following
serial numbers onwards:

Cette liste de pièces est valable pour les machines au
numéros de série à partir de:

Esta lista de piezas tiene validez para máquinas a partir del
número de serie siguiente:

PFAFF 1051 # 3-112296 →

PFAFF 1053 # 3-105519 →

PFAFF 1181 # 3-112301 →

PFAFF 1183 # 3-105529 →



Alle Informationen und Abbildungen waren zum Zeitpunkt der Druckgebung auf dem neuesten Stand.

Technische Änderungen vorbehalten!

Der Nachdruck, die Vervielfältigung sowie die Übersetzung – auch auszugsweise – aus PFAFF-Teilelisten ist nur mit unserer vorherigen Zustimmung und mit der Quellenangabe gestattet.

At the time of printing, all information and illustrations contained in this document were up to date.

Subject to alteration!

The reprinting, copying or translation of PFAFF parts lists whether in whole or in part, is only permitted with our previous permission and with written reference to the source.

Au moment de la remise à l'imprimeur, toutes les informations et figures se rapportant à cette machine correspondaient à l'état actuel des connaissances.

Sous réserve de modifications techniques!

Aucune reproduction, polycopie ou traduction – même par extraits – listes de pièces PFAFF ne peut être effectuée, à condition d'en indiquer l'origine, sans notre autorisation expresse.

Todas las informaciones e ilustraciones de este manual estaban al día en el momento de entregarse para su impresión.

¡ Salvo modificaciones técnicas!

La reimpresión, reproducción y traducción – aunque sólo sea parcial – de los manuales de instrucciones PFAFF sólo está permitida con nuestro permiso previo e indicando la fuente.

G.M. PFAFF
Aktiengesellschaft

Postfach 3020
D-67653 Kaiserslautern
Königstr. 154
D-67655 Kaiserslautern

Redaktion/Illustration
Verlag Technische Dokumentation
Postfach 1106
D-77901 Lahr

	Seite Page Page Página
0	Wichtiger Hinweis 0 - 1 Important note Avis important Observación importante
1	Vorwort 1 - 1 Foreword Avant-propos Notas preliminares
2	Erläuterungen der Schlüsselzeichen 2 - 1 Explanation of key markings Explication des symboles Explicaciones de los signos clave
3	Basismaschine Basic machine Machine de base Máquina básicas
3.01	Gehäuseteile 3 - 1 Housing sections Parties du corps Piezas del cárter
3.02	Kopfteile 3 - 2 Needle head parts Pièces de tête Piezas de la cabeza
3.03	Armteile 3 - 7 Arm parts Pièces de bras Piezas del brazo
3.04	Grundplattenteile 3 - 15 Bedplate parts Pièces du plateau fondamental Piezas del cárter

4	Fadenabschneid-Einrichtung (-900/24) 4 - 1 Thread trimmer (-900/24) Coupe-fil (-900/24) Cortahilos (-900/24)
5	Fadenabstreif-Einrichtung (-909/04) 5 - 1 Thread wiper (-909/04) Racleur de fil (-909/04) Retirahilos (-909/04)
6	Presserfuß-Automatik (-910/06) 6 - 1 Automatic presser foot lifter (-910/06) Relève-pied automatique (-910/06) Alzaprensateelas (-910/06)
7	Verriegelungs-Einrichtung (-911/37) 7 - 1 Backtacking mechanism (-911/37) Dispositif à points d'arrêt (-911/37) Rematador (-911/37)
8 8 - 1
9	Anbausatz für integrierten Motor Mounting kit for integrated motor Jeu de pièces pour moteur intégré Juego de piezas acoplables para motor integrado
9.01	Einbaumotor 9 - 1 Built-in motor Moteur incorporé Motor incorporado
9.02	Kabelbaum zum Oberteil 9 - 2 Cable tree to sewing head Faisceau de câbles vers la tête de machine Mazo de cables para el cabezal
9.03	Sollwertgeber 9 - 3 Set-point generator Codeur Emisor del valor teórico

9.04	Steuerkasten 9 - 4 Control box Boîtier de contrôle Caja de mandos
10	Garnrollenständer 10 - 1 Reel stands Porte-bobines Portacarretes
11	Einstellehren 11 - 1 Adjustment gauges Calibres Calibres de ajuste
12	Teile zur Tischplatte 11 - 1 Parts for table top Pièces du plateau Piezas para el tablero
13	Keilriemen 13 - 1 V-belt Courroie trapézoïdale Correa trapezoidal
14	Knieüferteile 13 - 1 Knee lifter parts Pièces du releveur de genouillère Piezas del alzaprensateles por rodillera
15	Schmiermittel-Übersicht 15 - 1 Overview of lubricants Tableau de lubrifiants Tabla de lubricantes
16	Index (Teilenummern / Seitenzahlen) 16 - 1 Index (part numbers / page numbers) Index (numéros de pièces, de pages) Index (números de pieza / números de página)
17	Unterklassen-Ausstattung Subclass parts Composition des sous-classes Composición de las subclases

17.01	Unterklassen-Übersicht (PFAFF 1051; 1181) 17 - 1 Table of subclasses (PFAFF 1051; 1181) Table de sous-classes (PFAFF 1051; 1181) Table de subclasses (PFAFF 1051; 1181)
17.02	Nähwerkzeuge (PFAFF 1051; 1181) 17 - 3 Gauge parts (PFAFF 1051; 1181) Organes de couture (PFAFF 1051; 1181) Organos de costura (PFAFF 1051; 1181)
17.03	Unterklassen-Übersicht (PFAFF 1053; 1183) 17 - 7 Table of subclasses (PFAFF 1053; 1183) Table de sous-classes (PFAFF 1053; 1183) Table de subclasses (PFAFF 1053; 1183)
17.04	Nähwerkzeuge (PFAFF 1053; 1183) 17 - 9 Gauge parts (PFAFF 1053; 1183) Organes de couture (PFAFF 1053; 1183) Organos de costura (PFAFF 1053; 1183)

Achtung!



Wir machen ausdrücklich darauf aufmerksam, daß Ersatz- und Zubehörteile, die nicht von uns geliefert werden, auch nicht von uns geprüft und freigegeben sind. Der Einbau und / oder die Verwendung solcher Produkte kann daher u. Umständen konstruktiv vorgegebene Eigenschaften Ihrer Maschine negativ verändern. Für Schäden, die durch die Verwendung von Nicht-Originalteilen entstehen, übernehmen wir keine Haftung!

Caution!



We warn you expressively that spare parts and accessories that are not supplied by us are not tested and released by us. Fitting or using these products may therefore have negative influences on features that depend on the machine design. We are not liable for any damage caused by the use of non-Pfaff parts!

Attention!



Nous attirons expressément votre attention sur le fait que les pièces de rechange et accessoires qui n'ont pas été livrés par nous n'ont pas non plus été contrôlés et agréés par nous. C'est pourquoi le montage et/ou l'utilisation de telles pièces peut éventuellement entraîner l'altération des caractéristiques de construction de votre machine. Par conséquent, nous n'assumons aucune responsabilité pour les dommages causés par l'emploi de pièces qui ne sont pas d'origine!

¡Atención!



Se hace observar que en el caso de piezas de recambio y accesorios que no hayan sido suministrados por nosotros, quiere decir que non han sido sometidas por nuestra parte a un control y que no se les ha dado el visto bueno. Por esta razón, el montaje y/o empleo de tales productos puede repercutir negativamente en las características previstas en su máquina. ¡Para los daños que eventualmente pudiesen presentarse al utilizar piezas no originales, no asumimos ninguna garantía!

- Die Seriennummer der Maschine, für die diese Teileliste Gültigkeit hat, ist auf der Titelseite aufgeführt.
- Alle Teile sind so abgebildet, wie sie in der Maschine funktionsmäßig zusammengehören.
- Gestrichelt dargestellte Teile zeigen angrenzende Teile aus anderen Funktionsgruppen.
- Im oberen Teil der Bildseiten befindet sich eine Gesamtansicht der Maschine .
Der Einbauort der dargestellten Teile wird durch eine gerasterte Fläche gekennzeichnet.
- Einrahmungen auf den Bildseiten zeigen, aus welchen Einzelteilen sich die Gruppenteile zusammensetzen.
- Die auf den Bildseiten verwendeten Schlüsselzeichen (; 2 ; 3 usw.) sind im Kapitel "Erläuterungen der Schlüsselzeichen" aufgelistet.

- The serial number of the machine to which this parts list applies is indicated on the cover page.
- All parts are illustrated in function groups with the parts which they function together with in the machine.
- Parts illustrated with broken lines are parts from other function groups which border on the illustrated function group.
- The above section of the page of illustrations contains a total view of the machine. The place for the installation of the parts pictured here is marked by the grid.
- The framed-in sections on the illustration pages show the individual parts comprising a group.
- The key markings used on the illustrated pages (; 2 ; 3 etc.) are listed in the chapter "Explanation of key markings".

- Le numéro de série de la machine pour laquelle cette liste de pièces est valable est indiqué sur la première page.
- Toutes les pièces sont représentées en fonction de leur groupement fonctionnel dans la machine.
- Les pièces hâchurées indiquent les pièces limitrophes de groupes de fonctions différents.
- La partie supérieure des pages de figures comprend une présentation globale de la machine. L'emplacement des pièces représentées est signalé par quadrillages.
- Les parties encadrées sur les pages à illustrations représentent les pièces individuelles formant groupe.
- Vous trouverez au chapitre "Explication des symboles" une liste des symboles utilisés sur les pages de figures (; 2 ; 3 etc.)

- El número de serie de la máquina para la cual tiene validez esta lista de piezas va indicado en la página de título.
- Todas las piezas están ilustradas tal como aparecen en la máquina para su funcionamiento.
- Las piezas representadas con rayitas muestran piezas colindantes de otros grupos de funciones.
- En la parte superior de las páginas ilustradas se puede ver una vista en conjunto de la máquina. El lugar de montaje de la pieza representada va caracterizada mediante una superficie reticulada.
- Los recuadros en las páginas ilustradas indican las piezas individuales de que se componen los grupos.
- Los signos clave (; 2 ; 3 etc.) empleados en las páginas con ilustraciones van listados en el capítulo "Explicaciones de los signos clave".

- Unterklassenabhängig, Teilenummer siehe Unterklassen-Ausstattung.
Subclass-dependent, for part number see subclass parts listing.
Fonction de la sous-classe; pour le numéro de la pièce, voir "Équipement de sous-classes".
Dependientes de la subclase, para el número de pieza véase "Dotación de subclases".
- 2 Markierung (Punkte, Striche oder Zahl) bei Bestellung angeben.
Marking (dots, strokes or numbers) to be stated on order.
Préciser les repères (points, traits ou chiffres) à la commande.
Señales (puntos, rayas o cifras), indíquese en los pedidos.
- 3/4 Selbstklebend
Self-adhesive
Auto-adhésive
Autoadhesivo
- 6 Nadeldicke und Spitzenform bei Bestellung angeben.
Needle size and style of point to be stated on order.
Préciser la grosseur de l'aiguille et la forme de la pointe à la commande.
Grosor de aguja y forma de la punta, indíquese en los pedidos.
- 6/3 Für 1,64 mm Nadelkolbendicke
For needle thickness of 1.64 mm
Pour grosseur d'aiguille 1,64 mm
Para 1,64 mm de grosor de aguja
- 6/4 Für 2,00 mm Nadelkolbendicke
For needle thickness of 2.00 mm
Pour grosseur d'aiguille 2,00 mm
Para 2,00 mm de grosor de aguja
- 27/5 Eingeklammerte Zahl = Länge in mm.
Number in brackets = length in mm.
Chiffre entre parenthèses = longueur en mm.
Cifra entre paréntesis = largura en mm.
- 32 Beim Einbau dieses Teiles wird für die Paßgenauigkeit zum Anschlußteil keine Garantie übernommen; zweckmäßig vollständiges Aggregat bestellen.
No guarantee is assumed that this part will fit the mating part; it is best to order a complete assembly.
Aucune garantie ne pourra être assurée quant à la précision d'ajustage de cette pièce avec la pièce correspondante; il est indiqué de commander un mécanisme complet.
Al montar esta pieza no se asume garantía alguna en cuanto a la tolerancia y precisión de ajuste respecto a la pieza correspondiente; por esta razón, se recomienda pedir el grupo completo.

- 32/1 Beim Einbau dieses Teiles ist Nacharbeit erforderlich.
When fitting this part re-work is required.
Retouches nécessaires au montage.
Al montar esta pieza hay que retocarla antes.
- 40/3 Fetten mit 28-011 202-47; Bestellnummer siehe Seite 15 - 1.
Grease with 28-011 202-47; for part number see page 15 - 1.
Graisser avec de la graisse 28-011 202-47; n° de commande, voir page 15 - 1.
Engrase con grasa 28-011 202-47; para el número de pedido véase la página 15 - 1.
- 40/4 Fetten mit 28-011 202-43; Bestellnummer siehe Seite 15 - 1.
Grease with 28-011 202-43; for part number see page 15 - 1.
Graisser avec de la graisse 28-011 202-43; n° de commande, voir page 15 - 1.
Engrase con grasa 28-011 202-43; para el número de pedido véase la página 15 - 1.
- 40/13 Fetten mit 28-011 202-05; Bestellnummer siehe Seite 15 - 1.
Grease with 28-011 202-05; for part number see page 15 - 1.
Graisser avec de la graisse 28-011 202-05; n° de commande, voir page 15 - 1.
Engrase con grasa 28-011 202-05; para el número de pedido véase la página 15 - 1.
- 40/23 Tränken mit 28-011 201-05; Bestellnummer siehe Seite 15 - 1.
Grease with 28-011 201-05; for part number see page 15 - 1.
Graisser avec de la graisse 28-011 201-05; n° de commande, voir page 15 - 1.
Engrase con grasa 28-011 201-05; para el número de pedido véase la página 15 - 1.
- 40/24 Ölen mit 28-011 201-05; Bestellnummer siehe Seite 15 - 1.
Oil with 28-011 201-05; for part number see page 15 - 1.
Huiler avec de la graisse 28-011 201-05; n° de commande, voir page 15 - 1.
Lubrifique con grasa 28-011 201-05; para el número de pedido véase la página 15 - 1.
- 96 Länge angeben.
State length.
Préciser longueur.
Indíquese la largura.

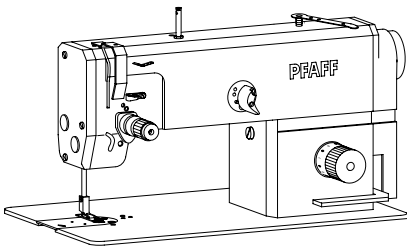

Gehäuseteile	PFAFF 1051
Housing sections	PFAFF 1053
Parties du corps	PFAFF 1181
Piezas del cárter	PFAFF 1183

3.01

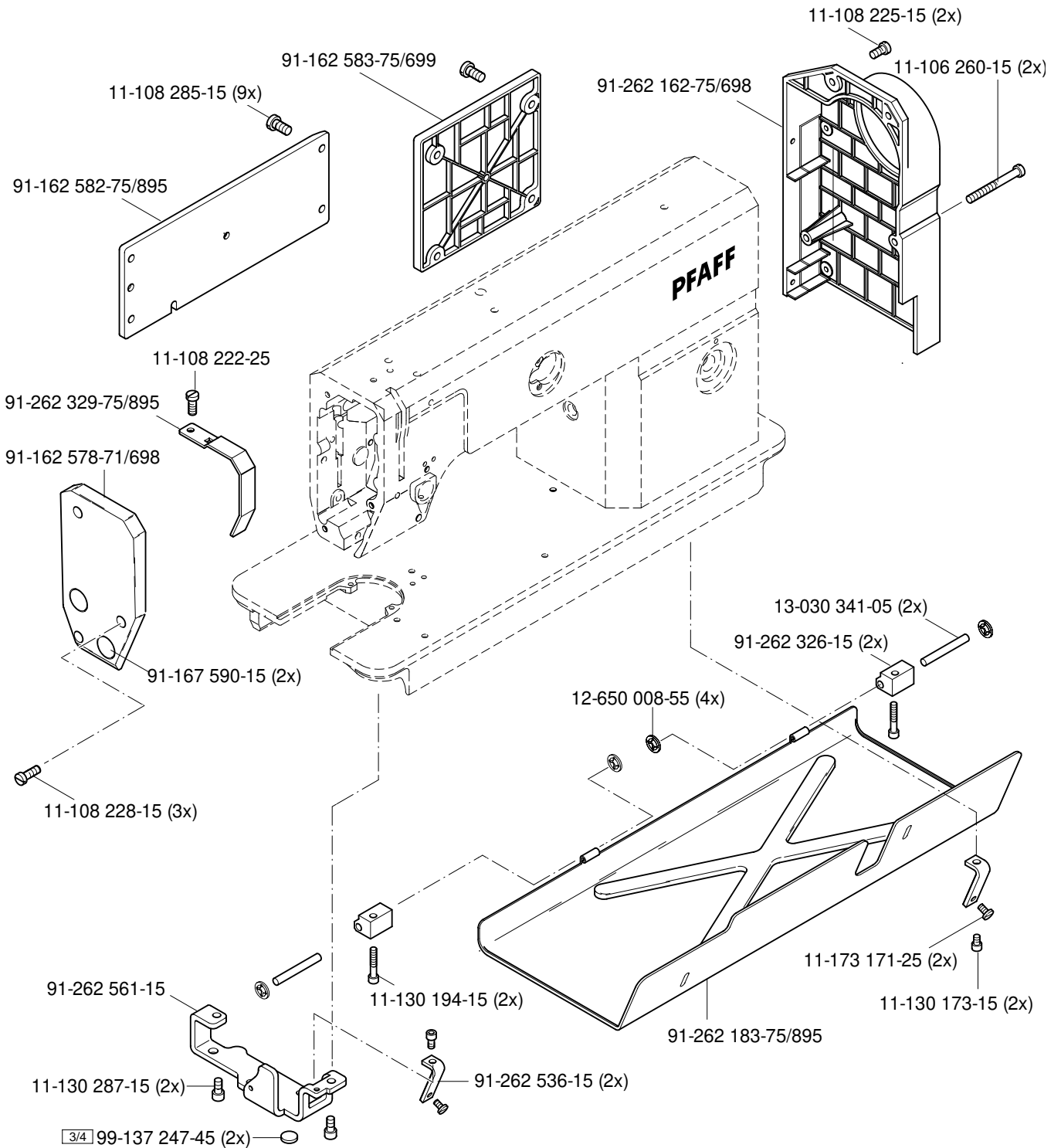

3.02

Kopfteile PFAFF 1051
 Needle head parts PFAFF 1053
 Pièces de tête PFAFF 1181
 Piezas de la cabeza PFAFF 1183

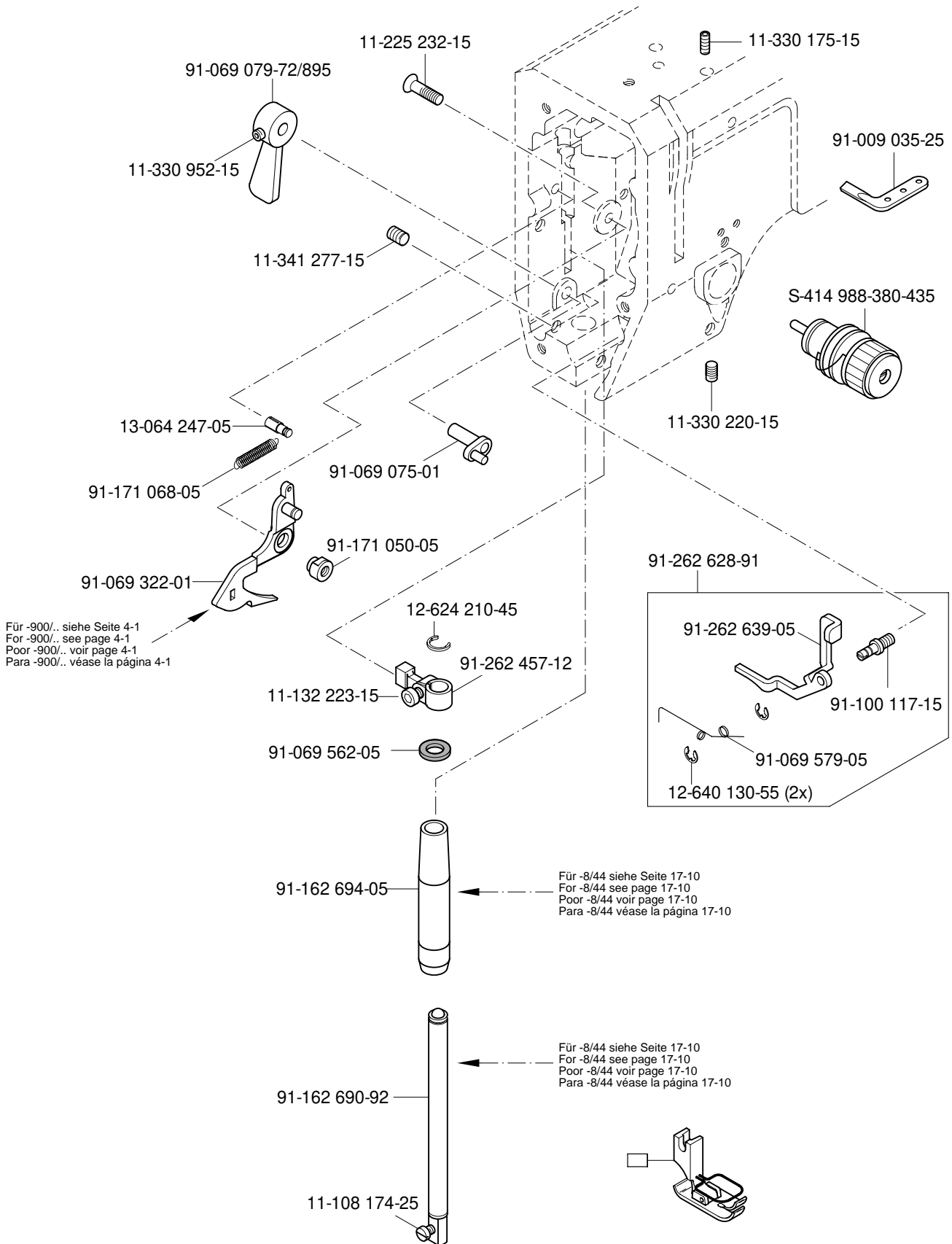
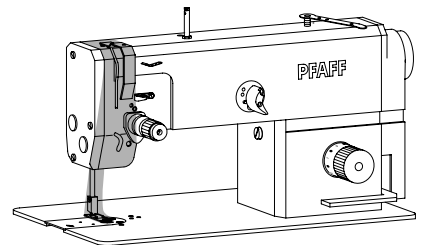

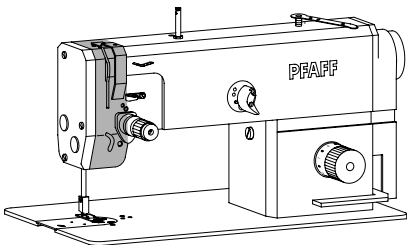

Kopfteile PFAFF 1051
 Needle head parts PFAFF 1053
 Pièces de tête PFAFF 1181
 Piezas de la cabeza PFAFF 1183

3.02

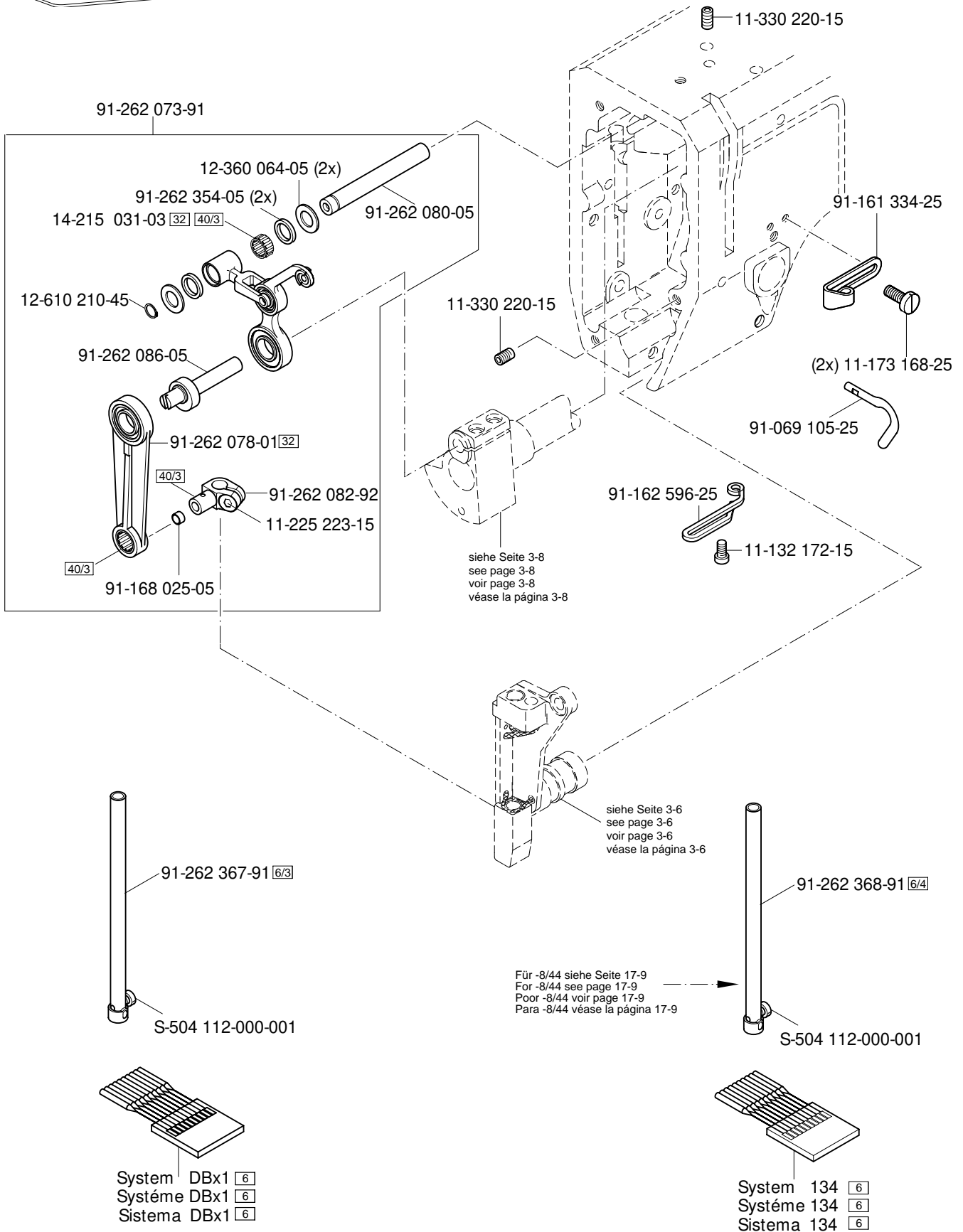

3.02

Kopfteile
 Needle head parts
 Pièces de tête
 Piezas de la cabeza PFAFF 1051

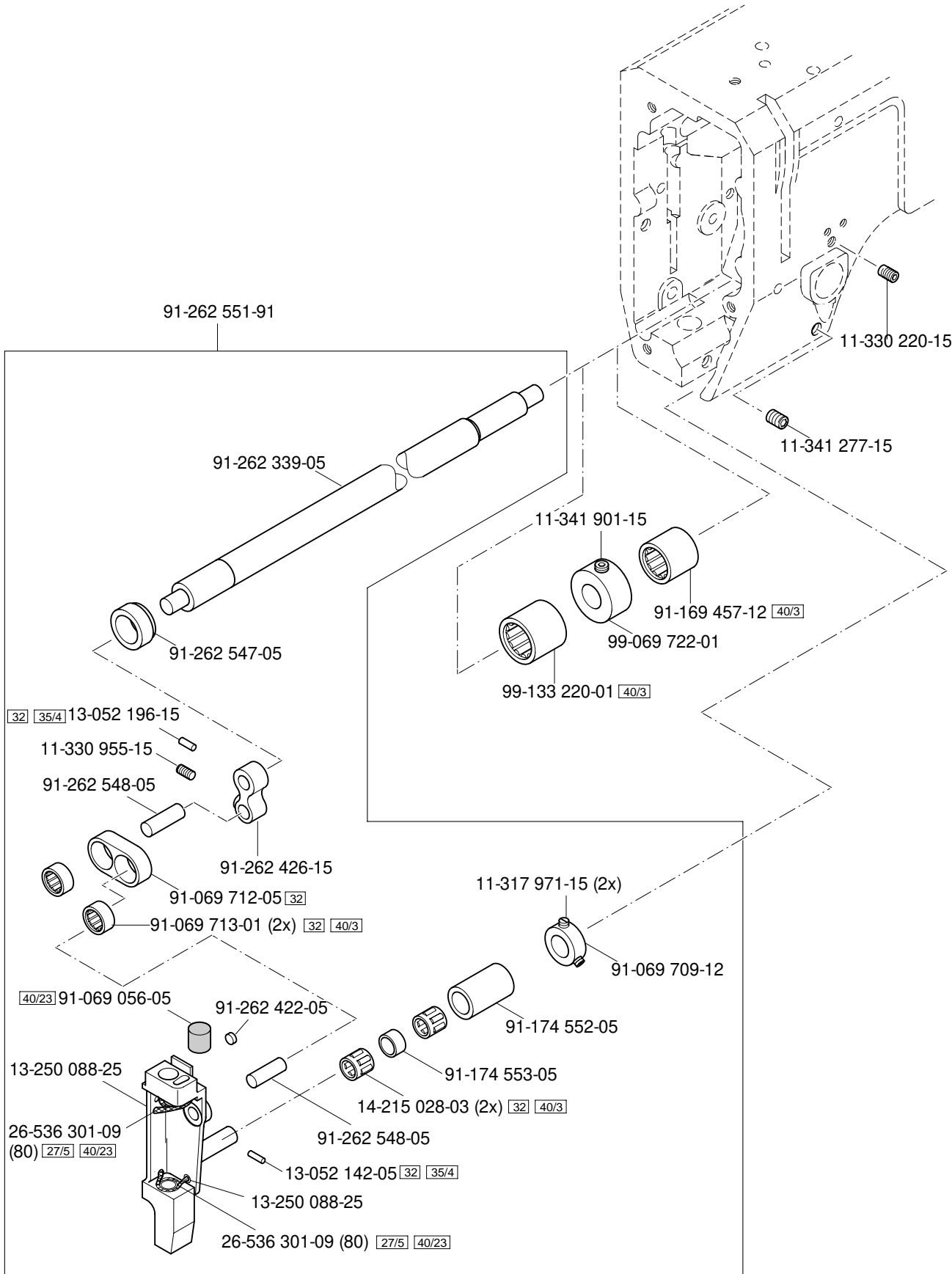
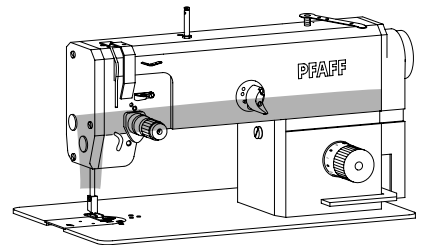

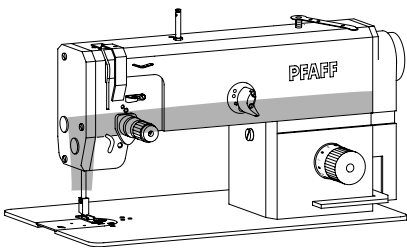

Kopfteile
Needle head parts
Pièces de tête
Piezas de la cabeza PFAFF 1181

3.02

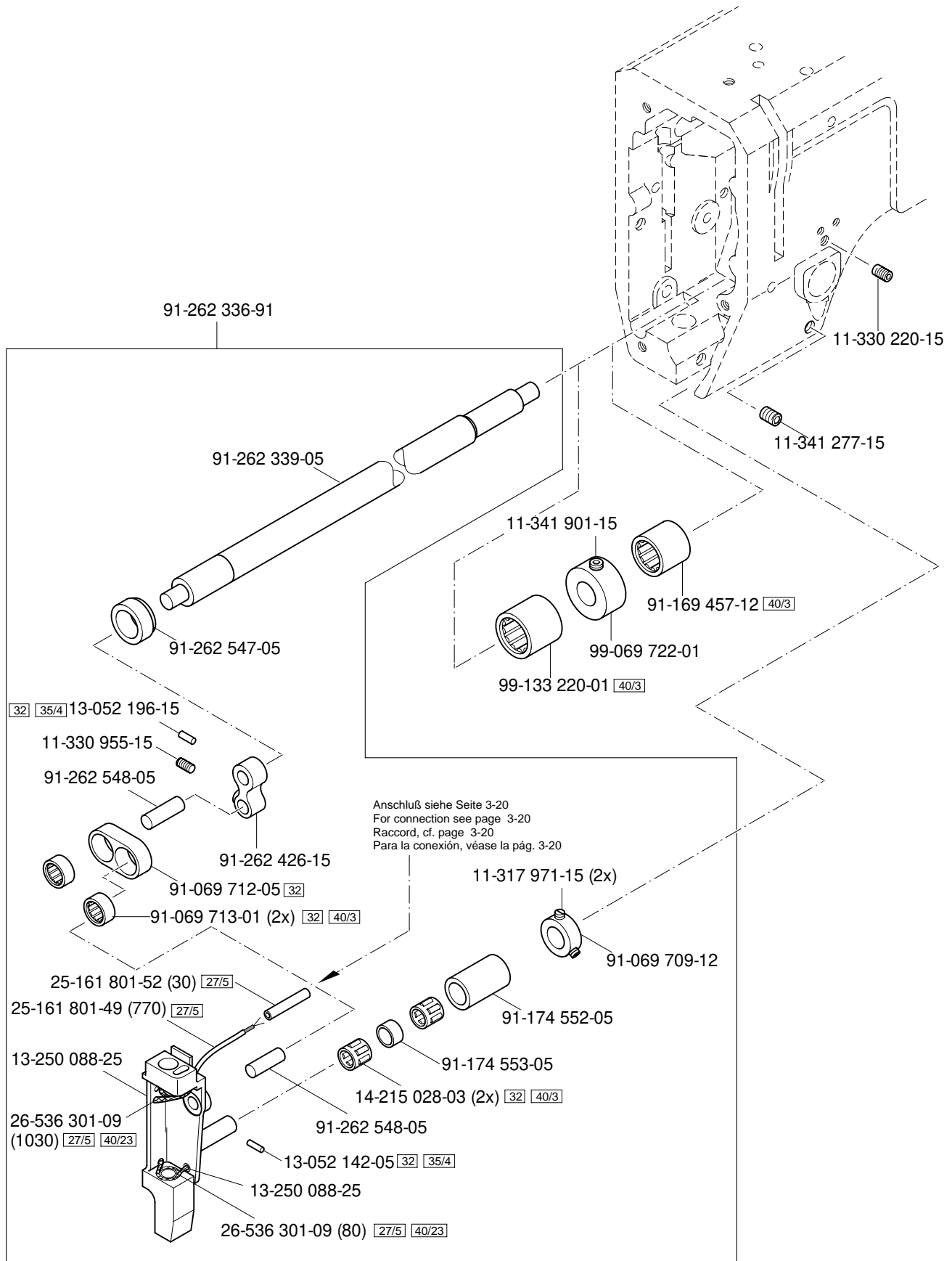

3.02

Kopfteile
 Needle head parts
 Pièces de tête
 Piezas de la cabeza

PFAFF 1053
 PFAFF 1183

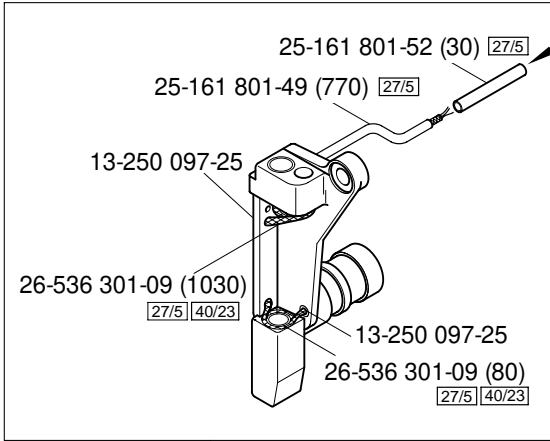
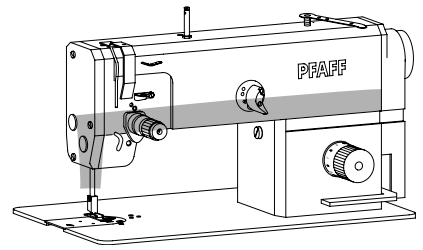

91-262 320-91 (PFAFF 1183)

Anschluß siehe Seite 3-20
 For connection see page 3-20
 Raccord, cf. page 3-20
 Para la conexión, véase la pág. 3-20

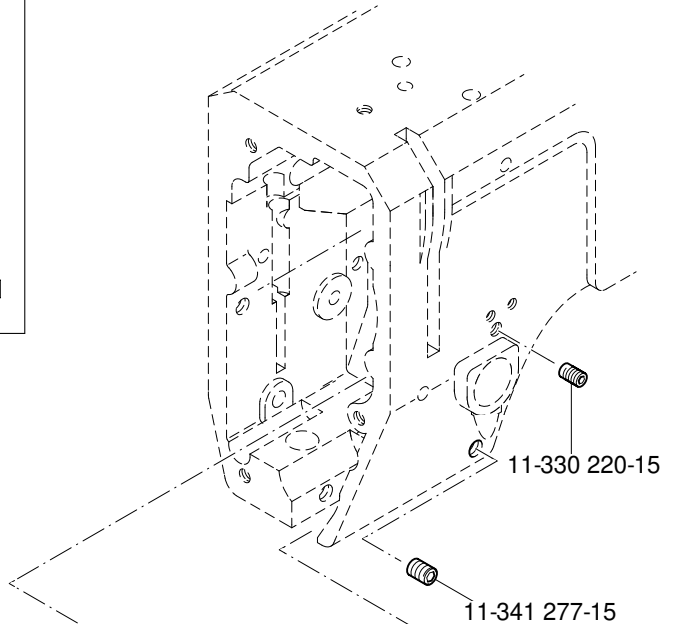

siehe Seite 3-3
 see page 3-3
 voir page 3-3
 véase la página 3-3

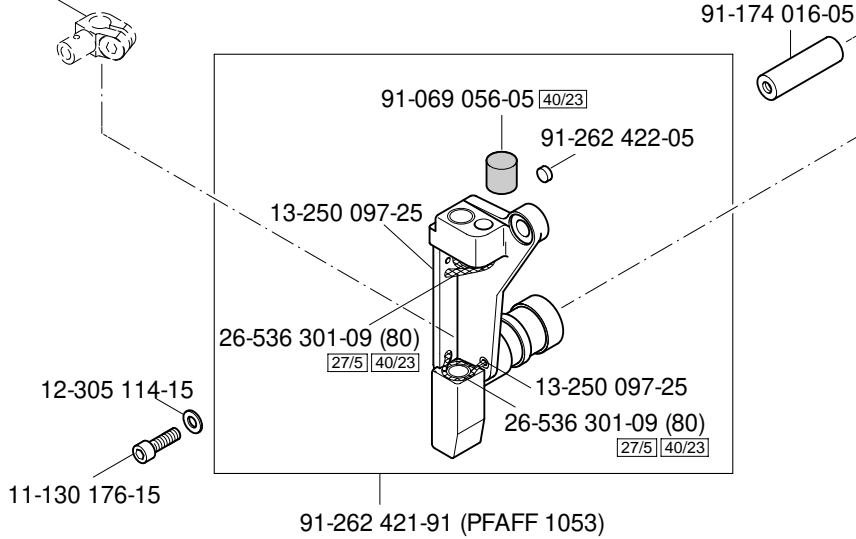

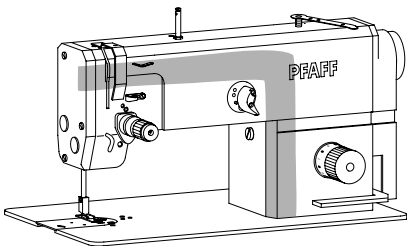

Armteile PFAFF 1051
 Arm parts PFAFF 1053
 Pièces de bras PFAFF 1181
 Piezas del brazo PFAFF 1183

3.03

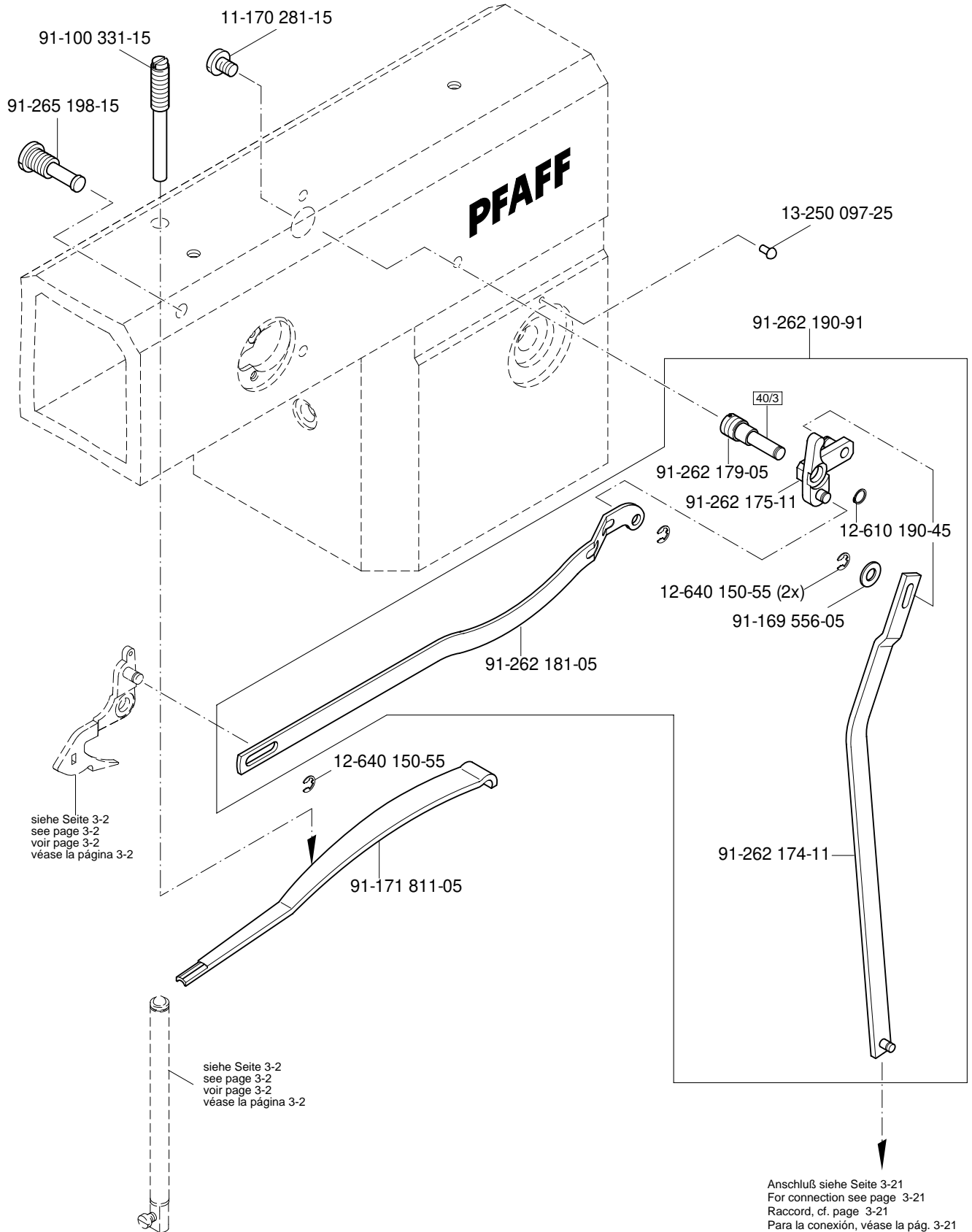

3.03

Armteile	PFAFF 1051
Arm parts	PFAFF 1053
Pièces de bras	PFAFF 1181
Piezas del brazo	PFAFF 1183

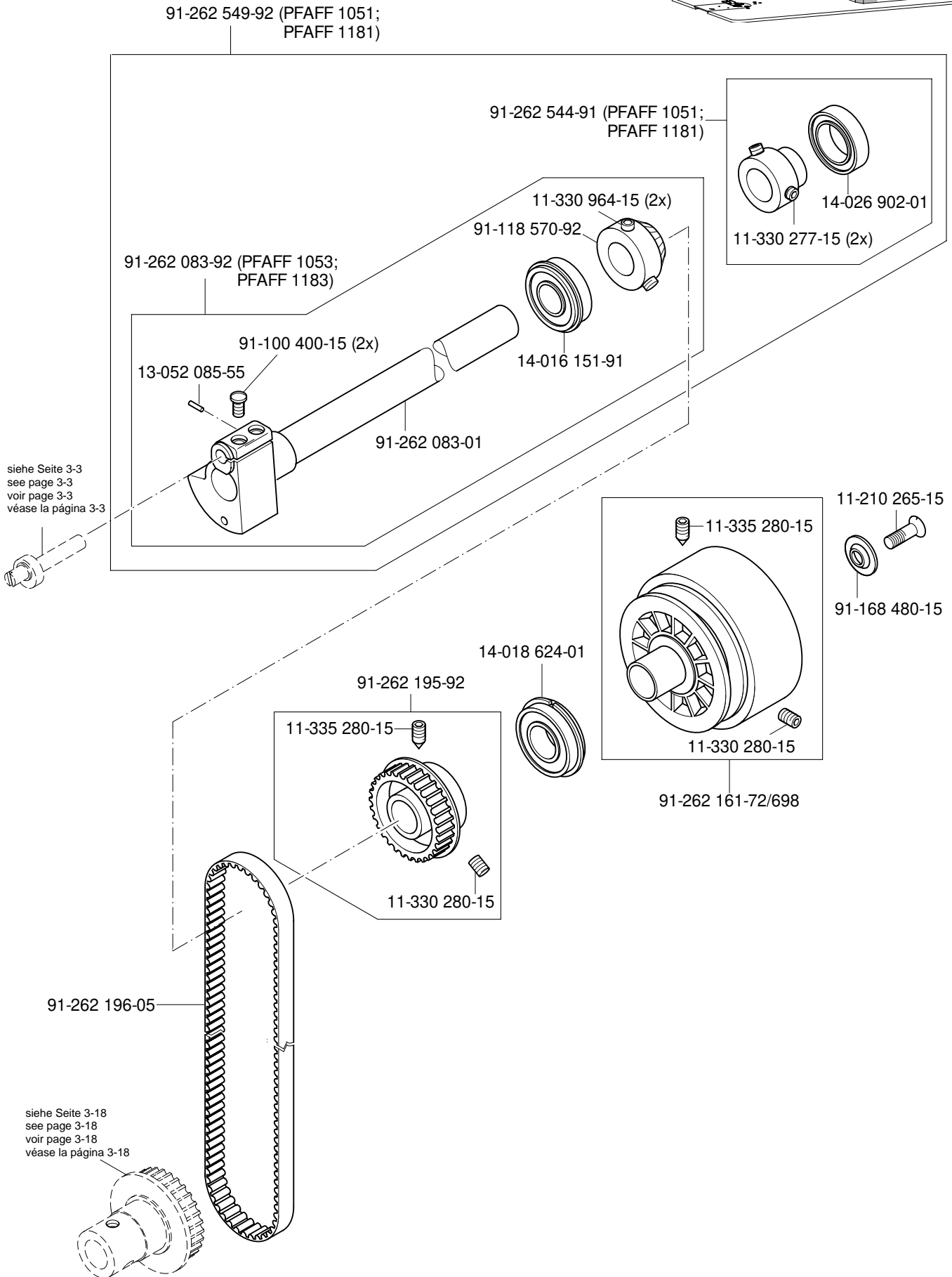
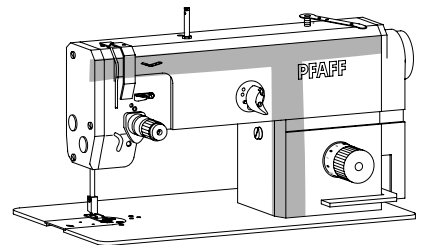

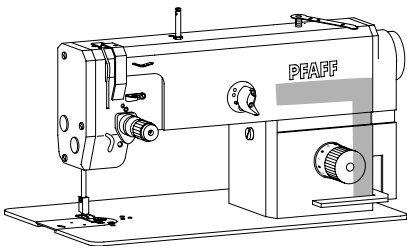

Armteile
 Arm parts
 Pièces de bras PFAFF 1051
 Piezas del brazo PFAFF 1181

3.03

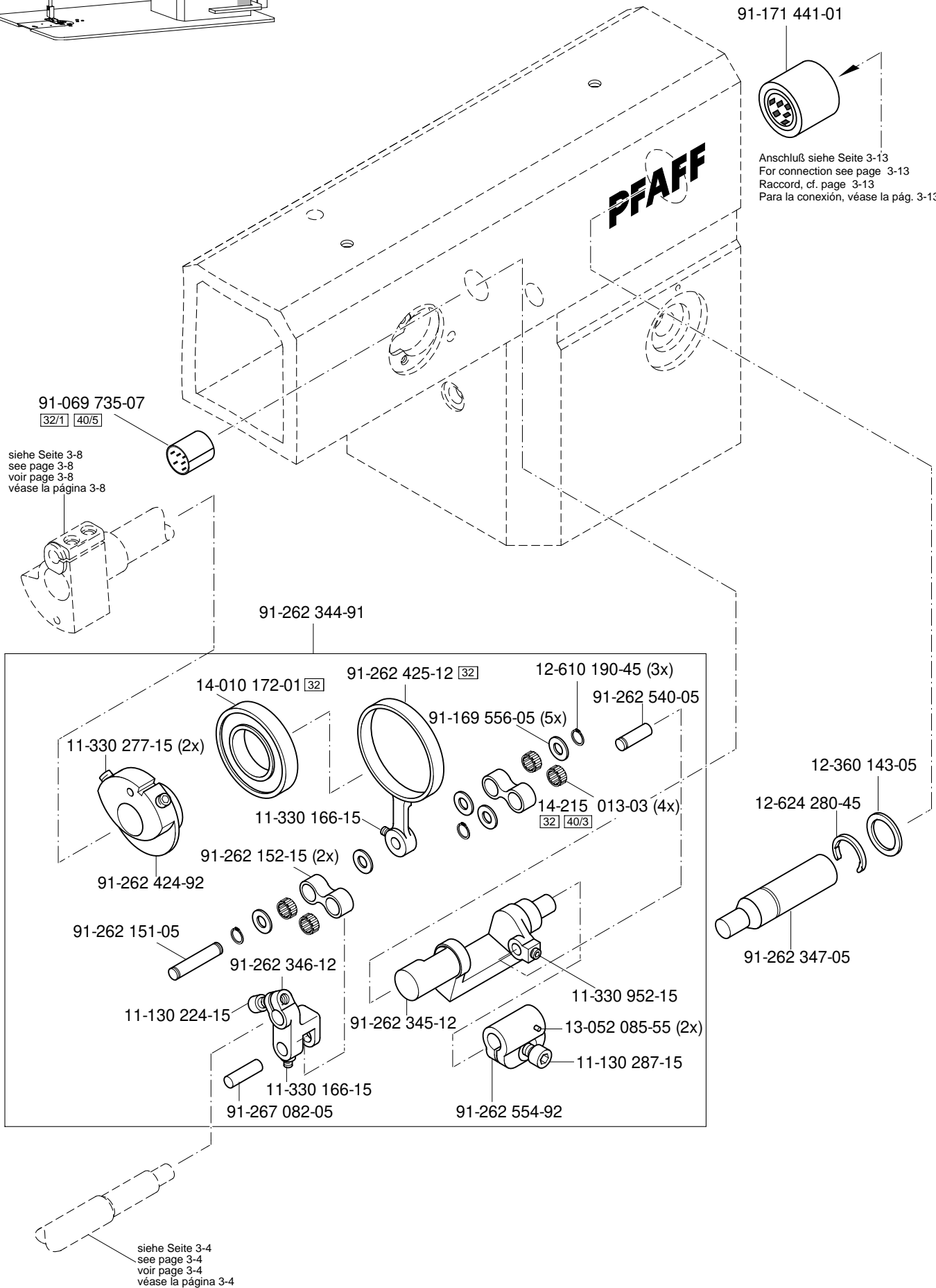

3.03

Armteile
 Arm parts
 Pièces de bras
 Piezas del brazo

PFAFF 1051
 PFAFF 1053
 PFAFF 1181
 PFAFF 1183

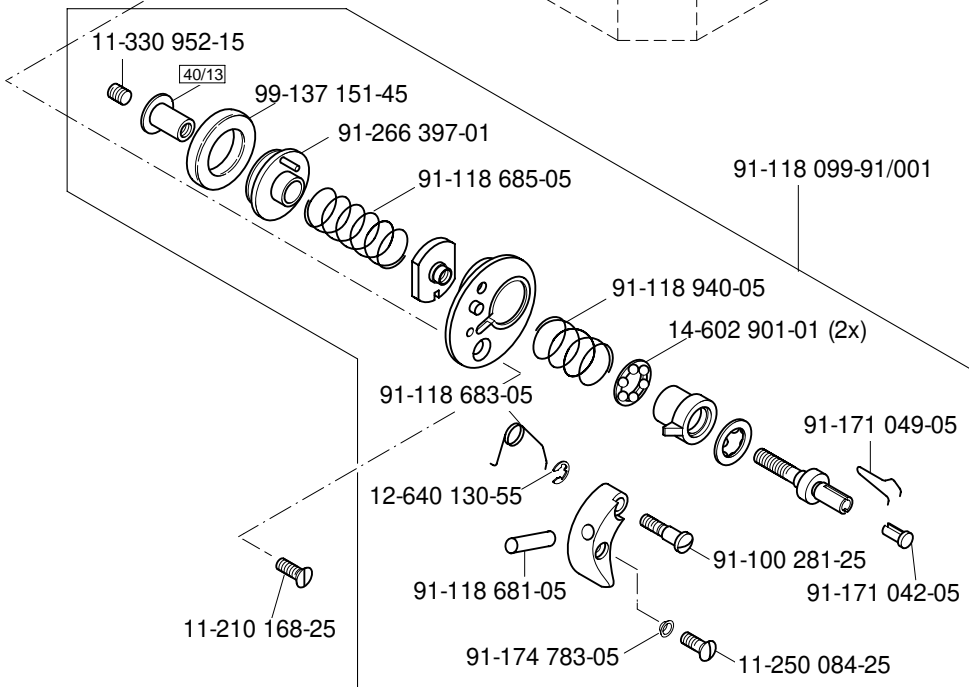
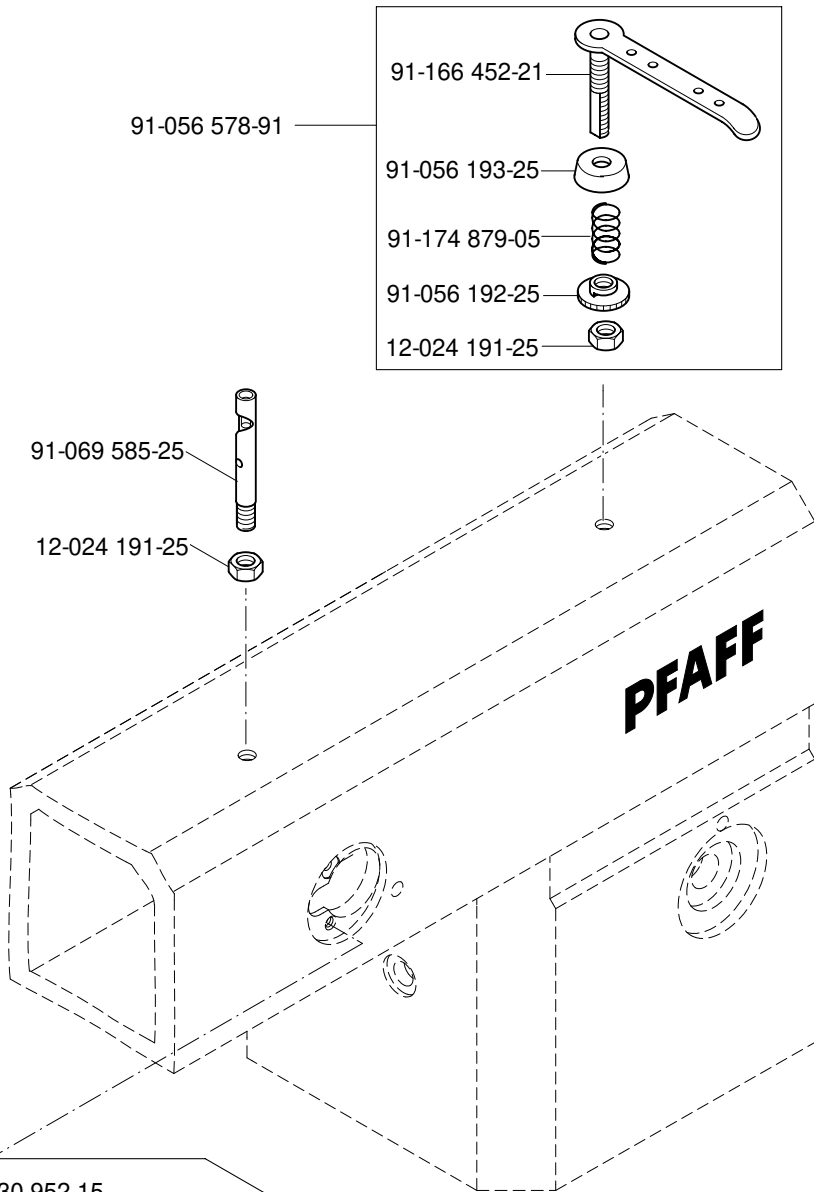
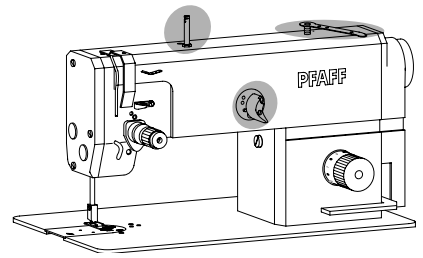

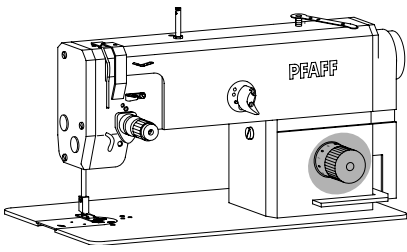

Armteile	PFAFF 1051
Arm parts	PFAFF 1053
Pièces de bras	PFAFF 1181
Piezas del brazo	PFAFF 1183

3.03

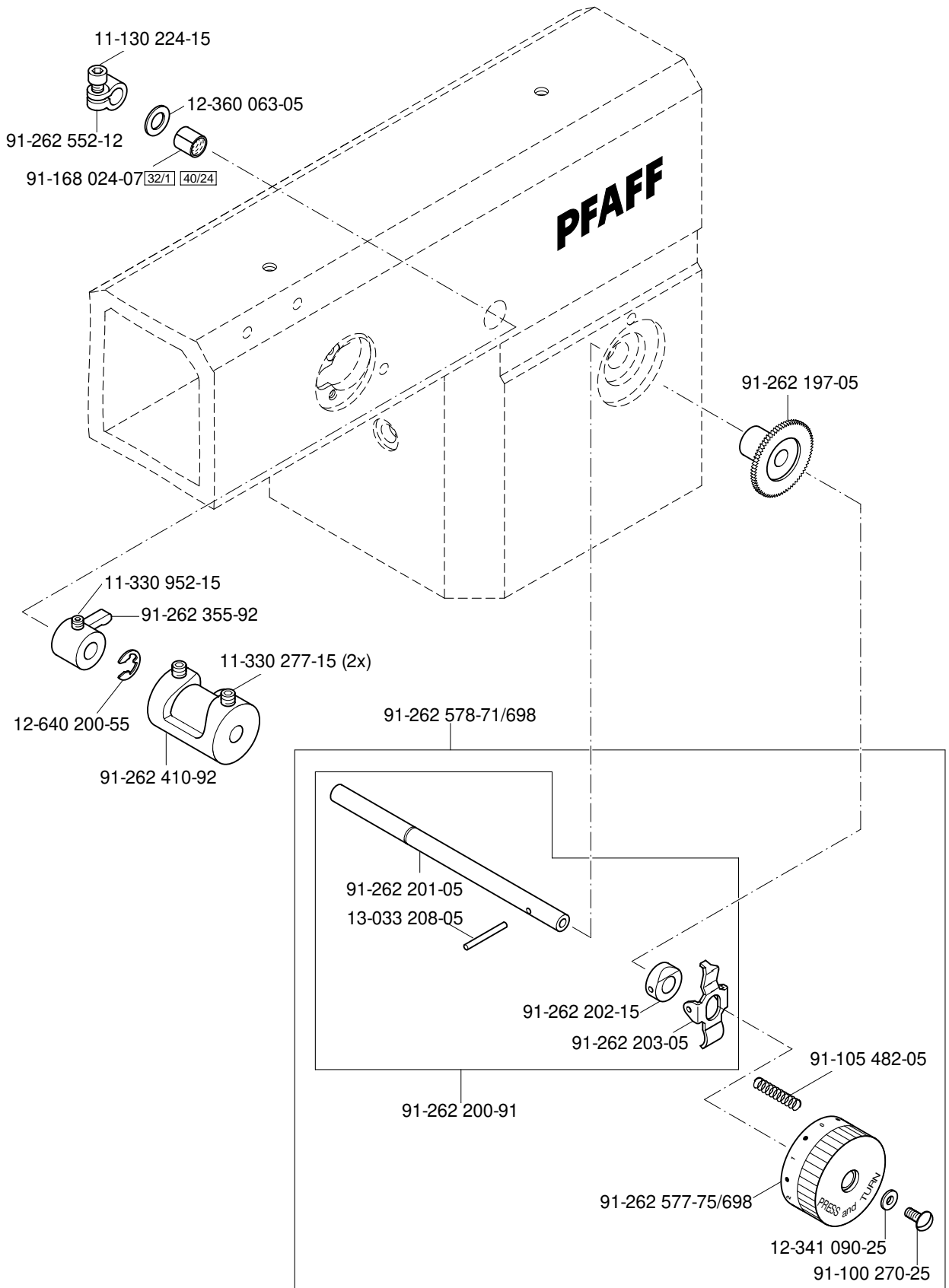

3.03

Armteile PFAFF 1051
 Arm parts PFAFF 1053
 Pièces de bras PFAFF 1181
 Piezas del brazo PFAFF 1183

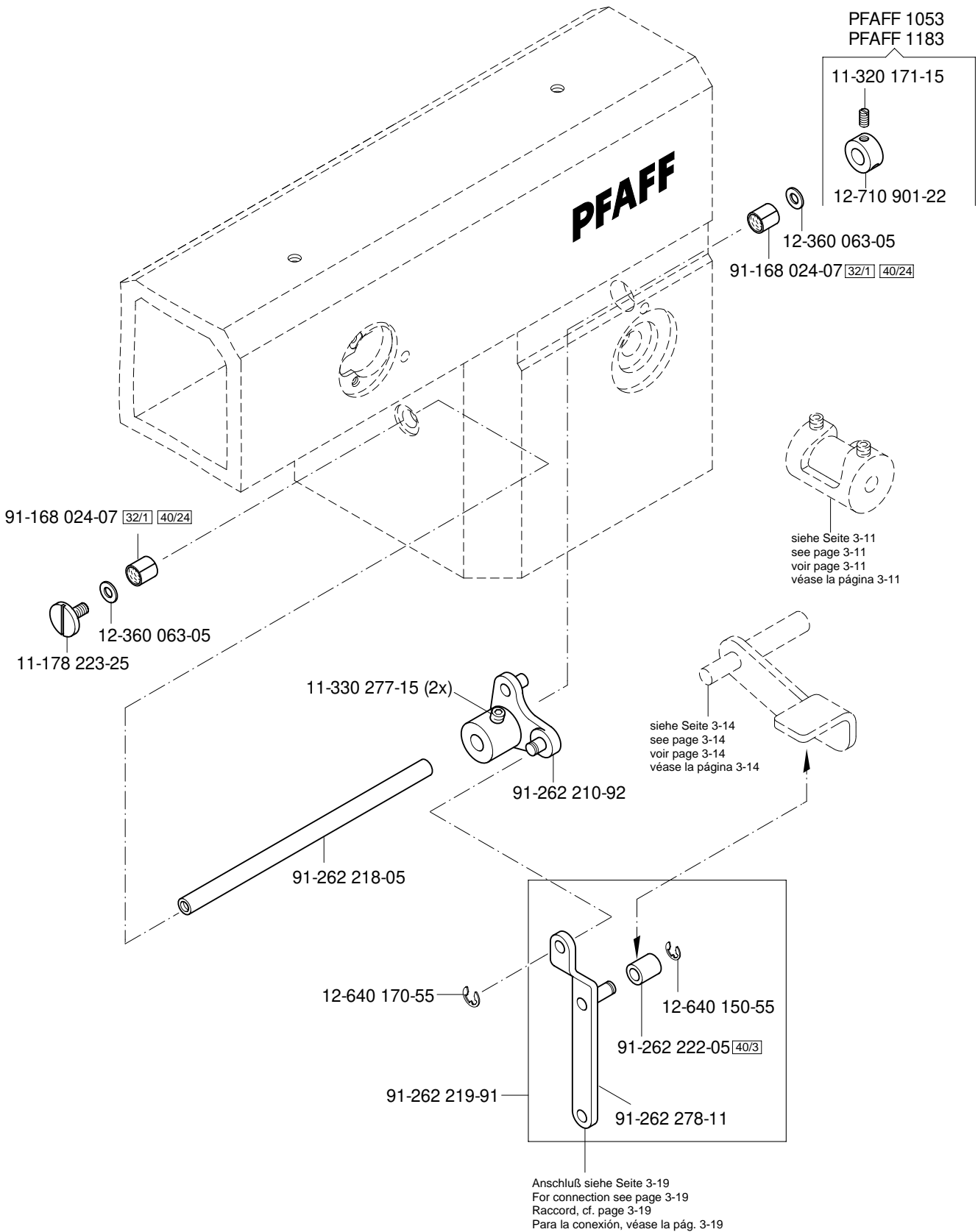
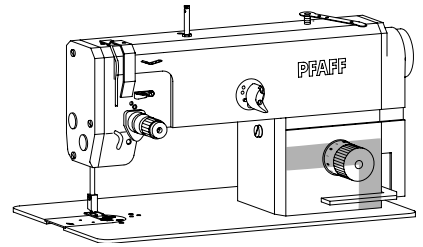

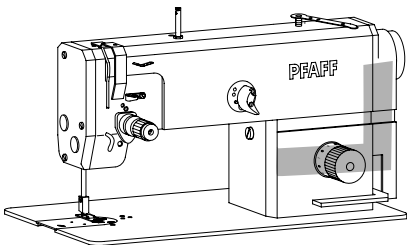

Armteile
 Arm parts
 Pièces de bras PFAFF 1051
 Piezas del brazo PFAFF 1181

3.03

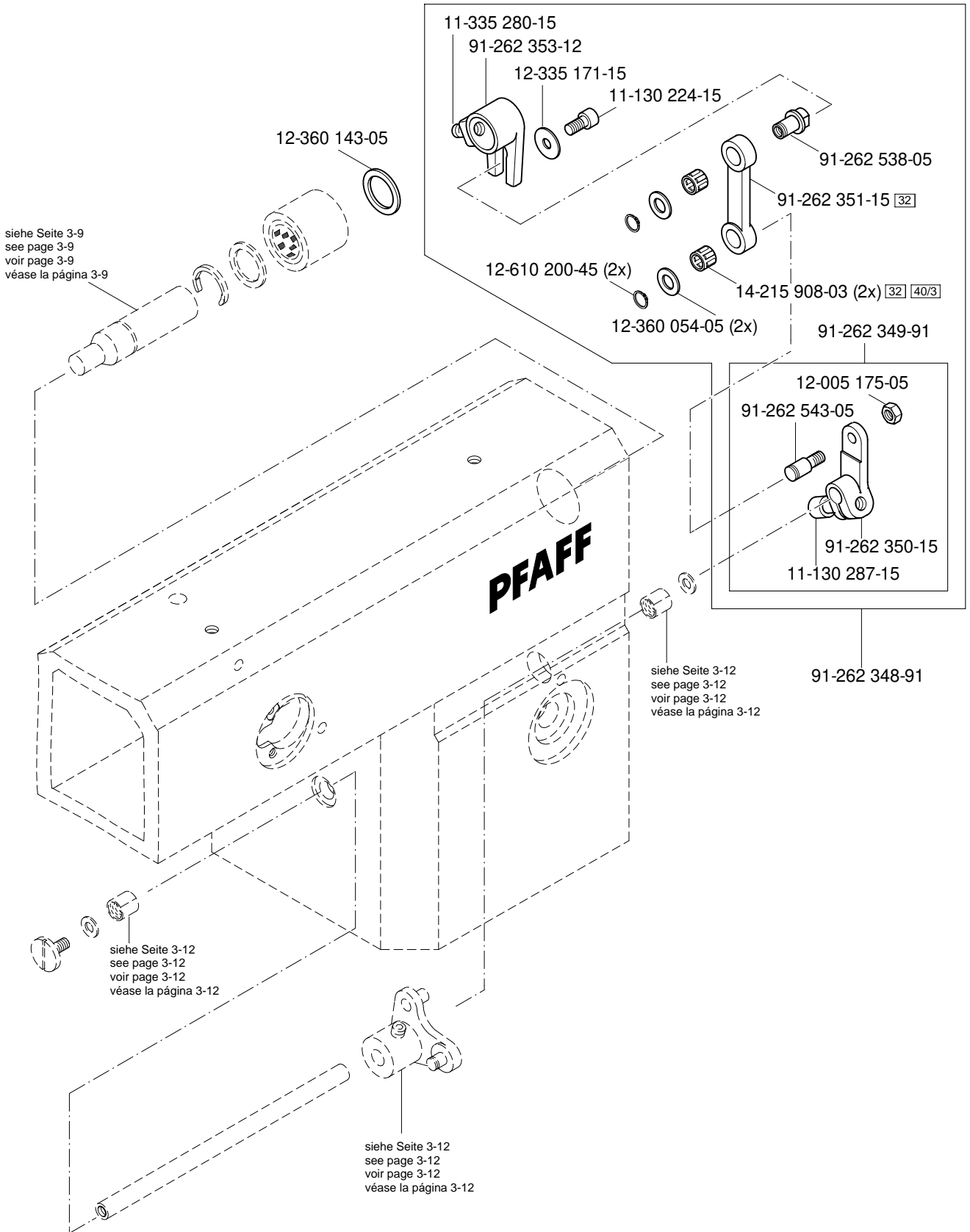

3.03

Armteile	PFAFF 1051
Arm parts	PFAFF 1053
Pièces de bras	PFAFF 1181
Piezas del brazo	PFAFF 1183

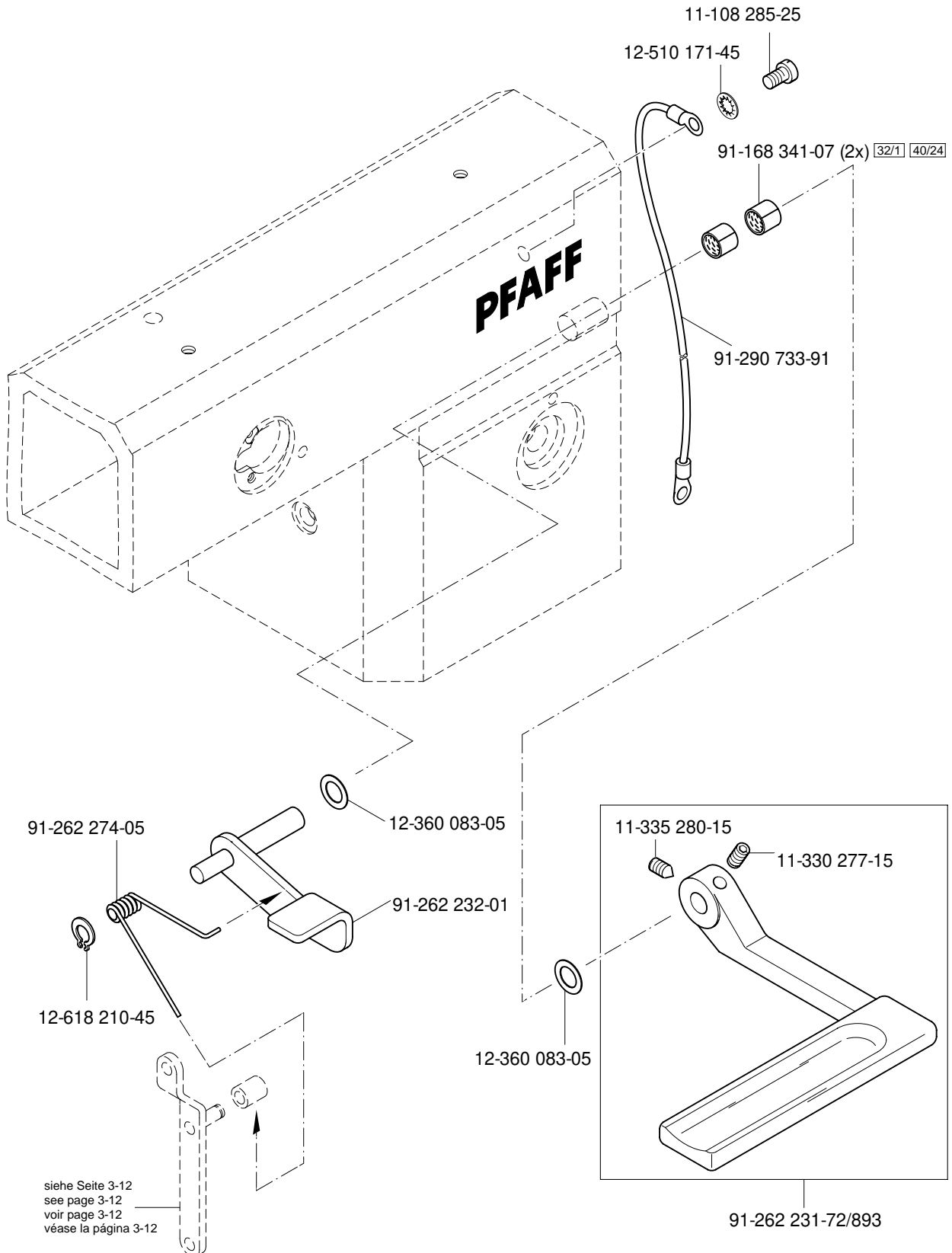
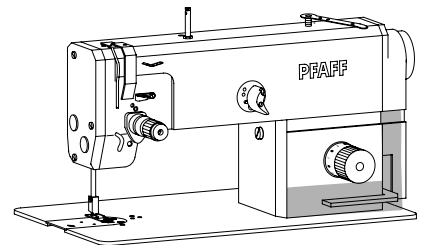

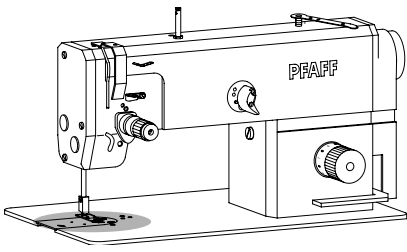

Grundplattenteile
 Bedplate parts
 Pièces du plateau fondamental
 Piezas del cárter

PFAFF 1051
 PFAFF 1053
 PFAFF 1181
 PFAFF 1183

3.04

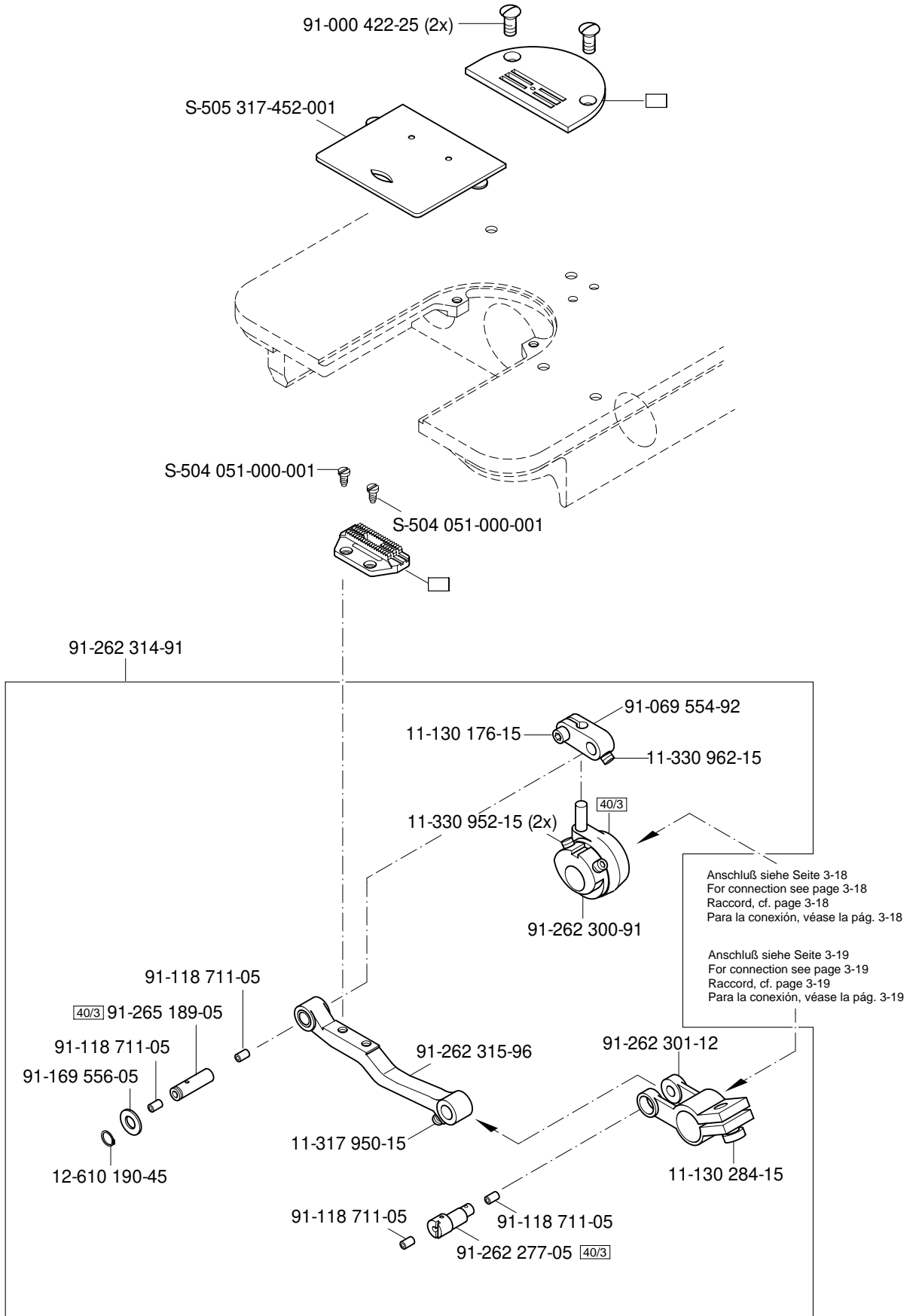

3.04

Grundplattenteile
 Bedplate parts
 Pièces du plateau fondamental PFAFF 1051
 Piezas del cárter PFAFF 1053

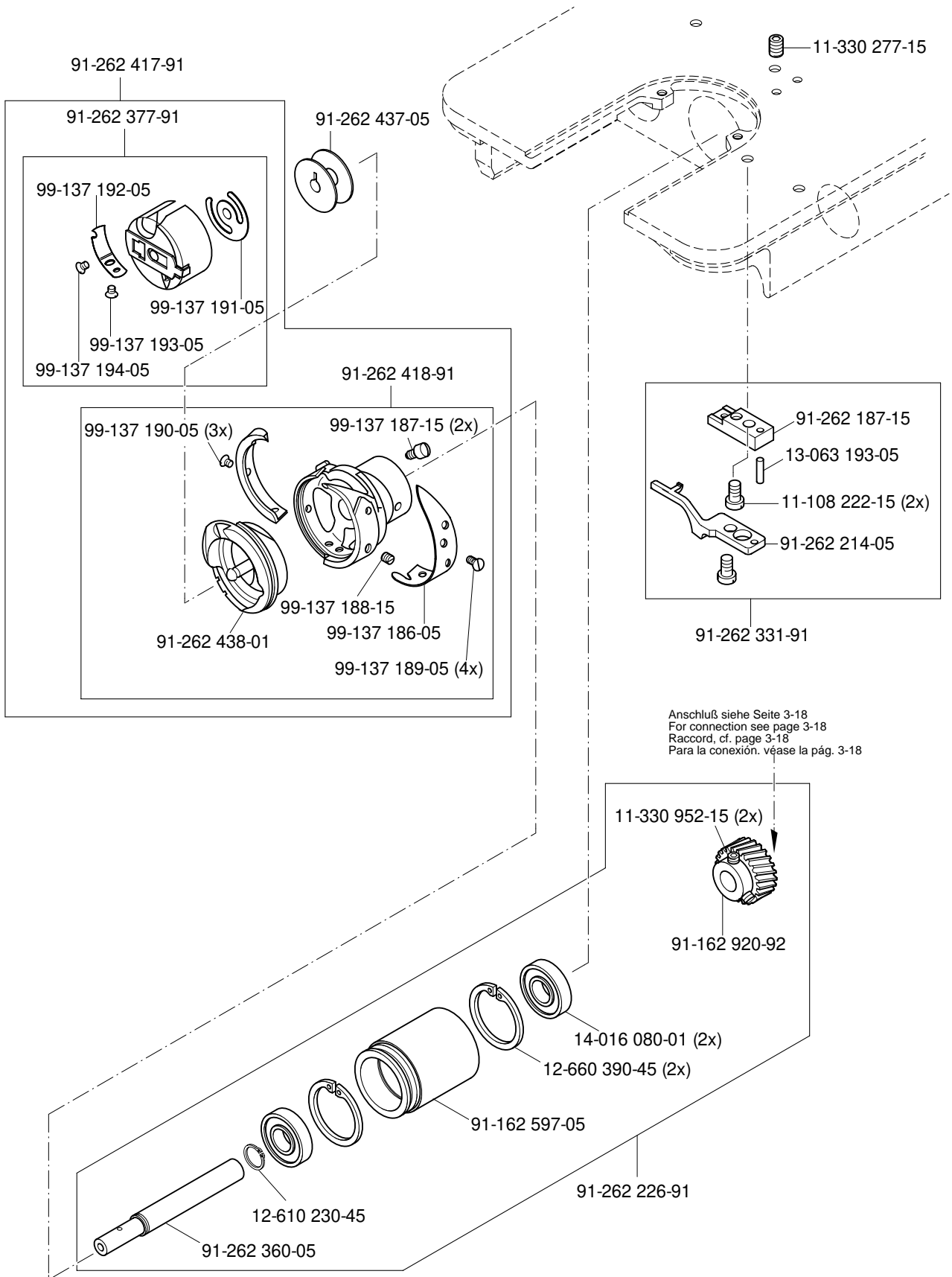
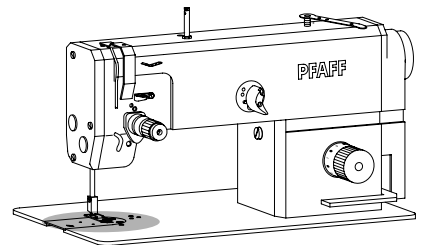

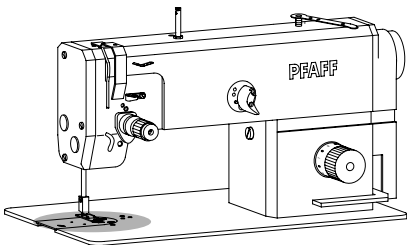

Grundplattenteile
 Bedplate parts
 Pièces du plateau fondamental
 Piezas del cárter

PFAFF 1181
 PFAFF 1183

3.04

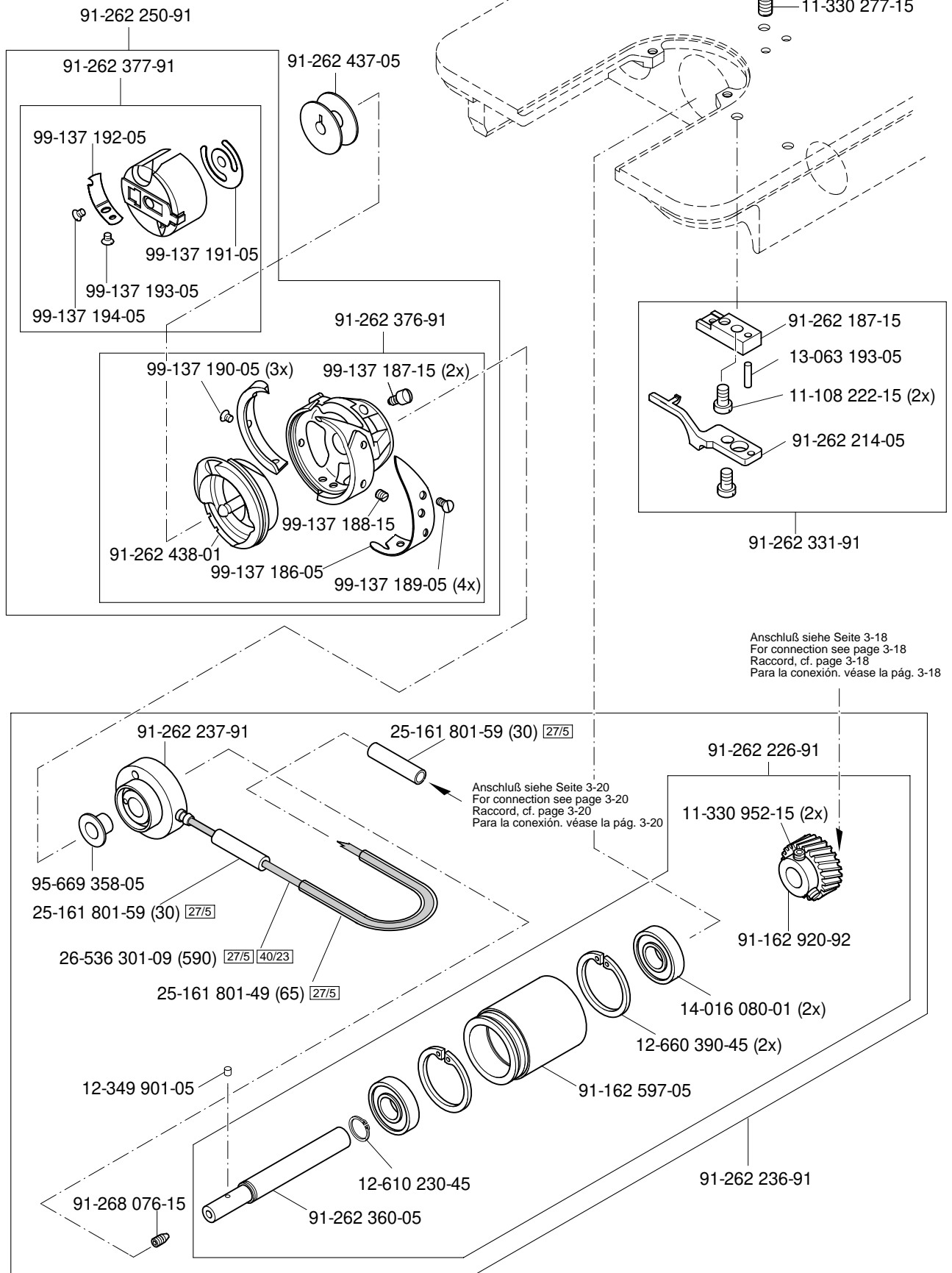

3.04

Grundplattenteile
Bedplate parts
Pièces du plateau fondamental
Piezas del cárter

PFAFF 1051
PFAFF 1053
PFAFF 1181
PFAFF 1183

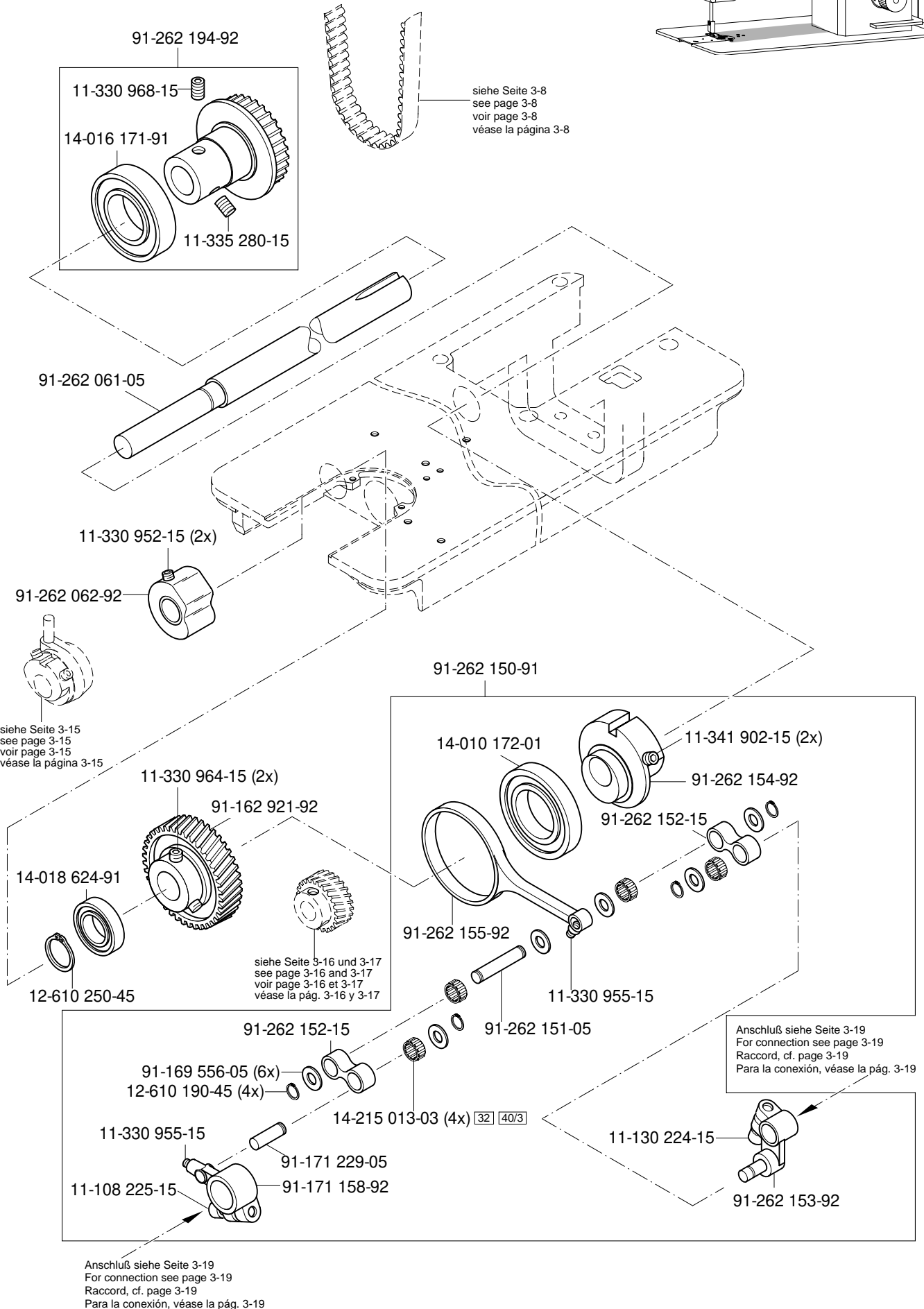
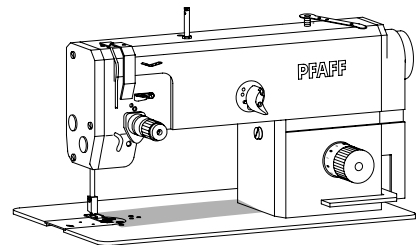

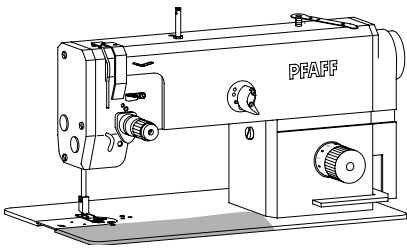

Grundplattenteile
 Bedplate parts
 Pièces du plateau fondamental
 Piezas del cárter

PFAFF 1051
 PFAFF 1053
 PFAFF 1181
 PFAFF 1183

3.04

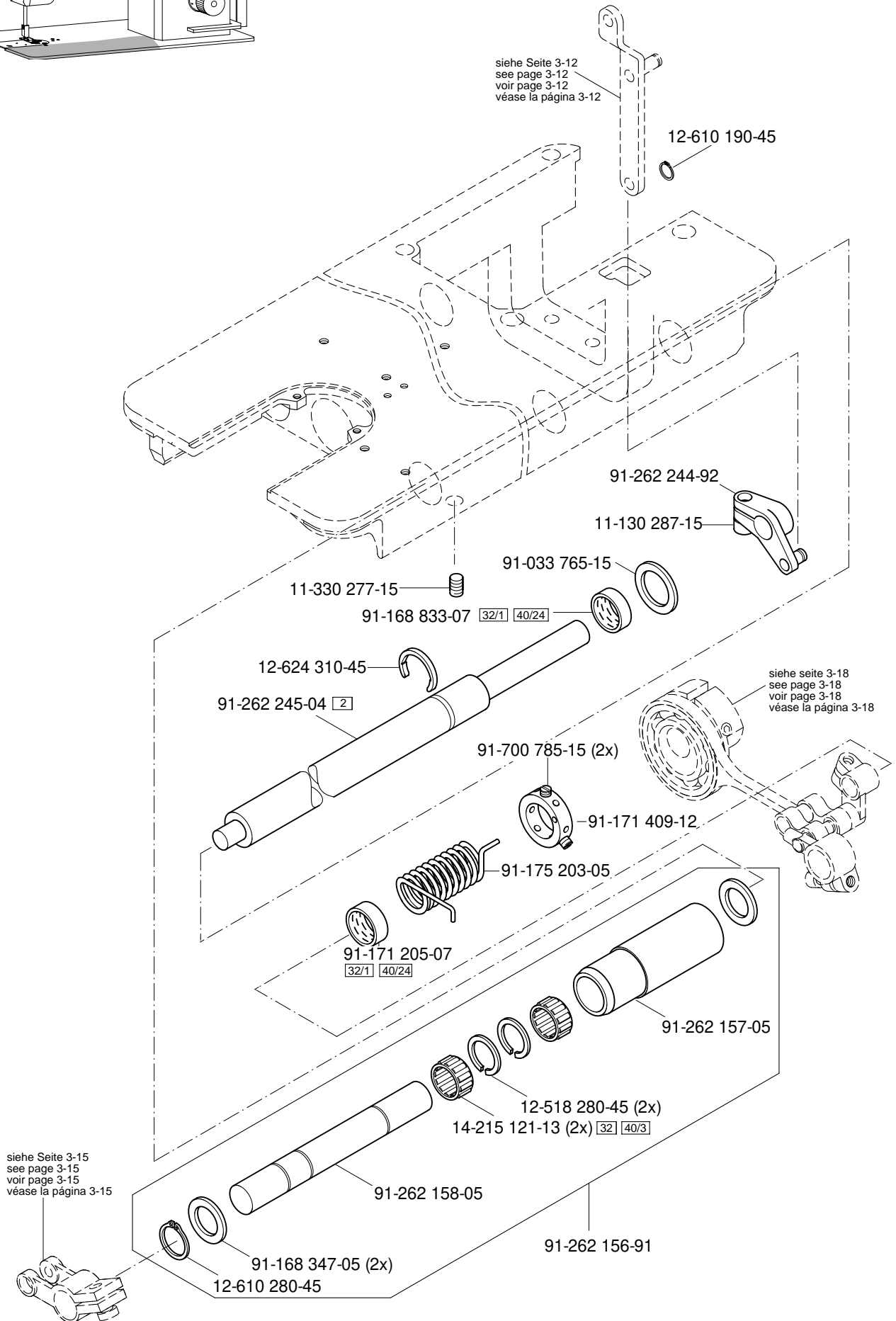

3.04

Grundplattenteile
Bedplate parts
Pièces du plateau fondamental
Piezas del cárter

PFAFF 1181
PFAFF 1183

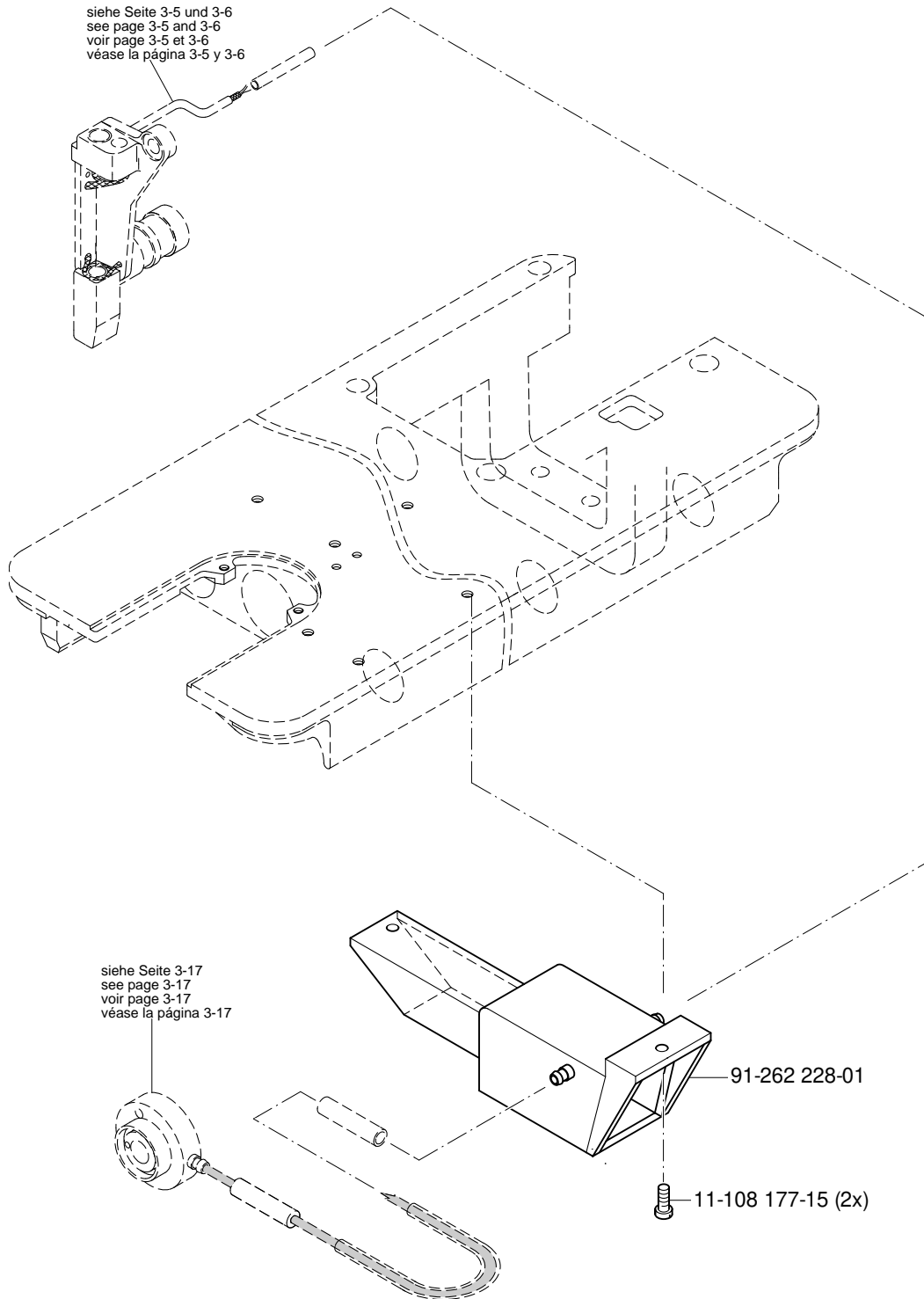
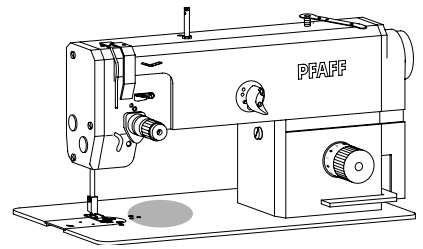

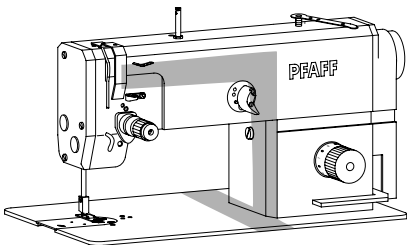

Grundplattenteile
 Bedplate parts
 Pièces du plateau fondamental
 Piezas del cárter

PFAFF 1051
 PFAFF 1053
 PFAFF 1181
 PFAFF 1183

3.04

siehe Seite 3-7
 see page 3-7
 voir page 3-7
 véase la página 3-7

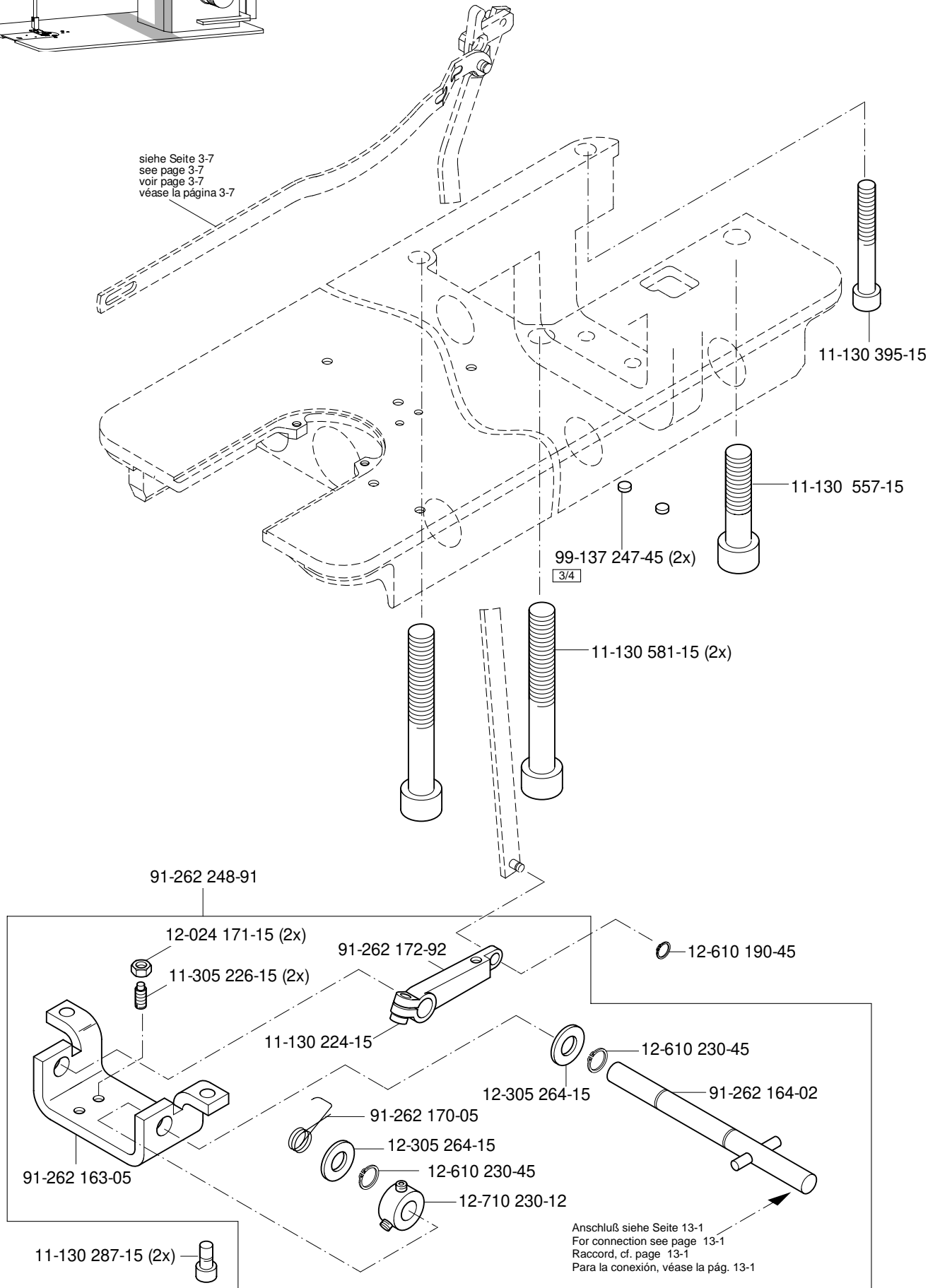

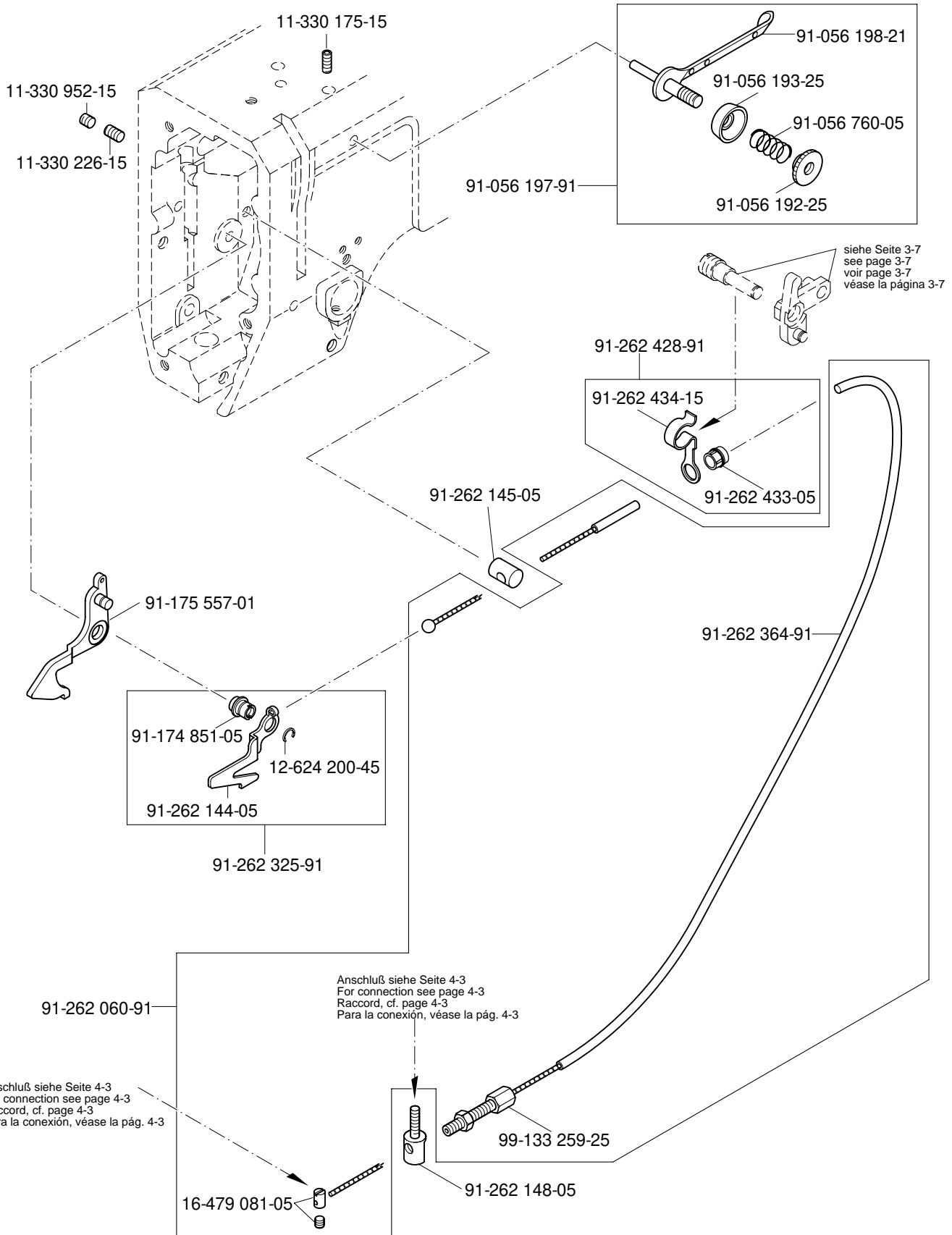
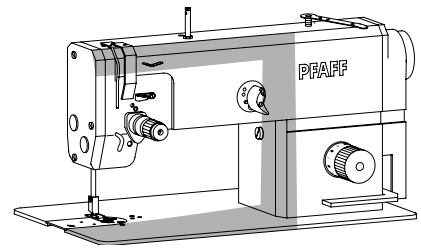

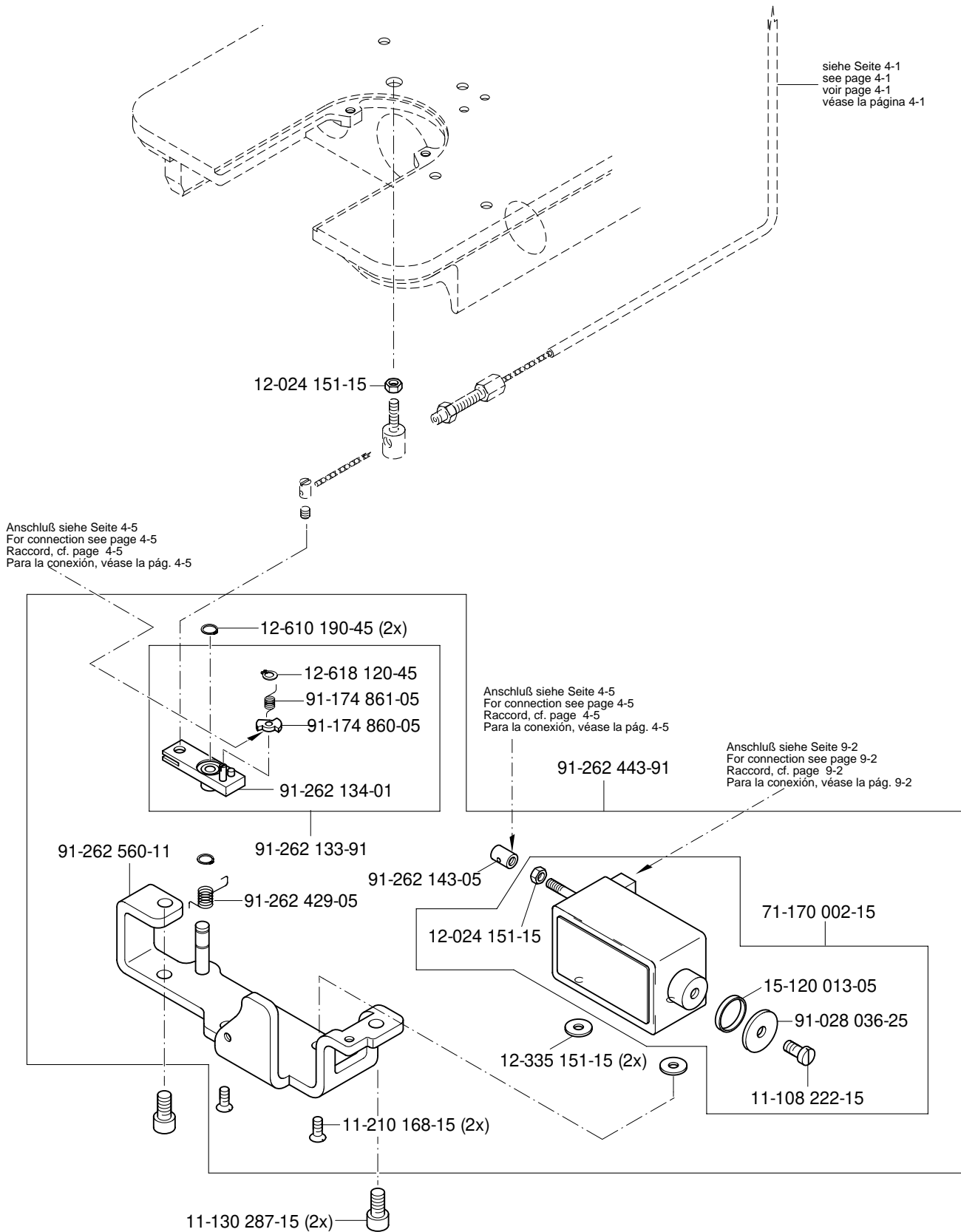
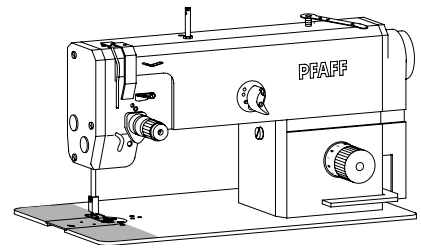

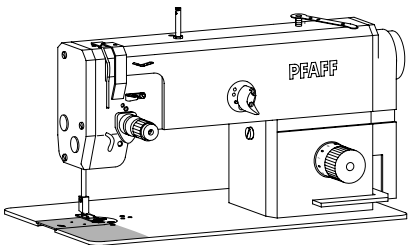

Fadenabschneid-Einrichtung (-900/24)
 Thread trimmer (-900/24)
 Coupe-fil (-900/24)
 Cortahilos (-900/24)

PFAFF 1051
 PFAFF 1181

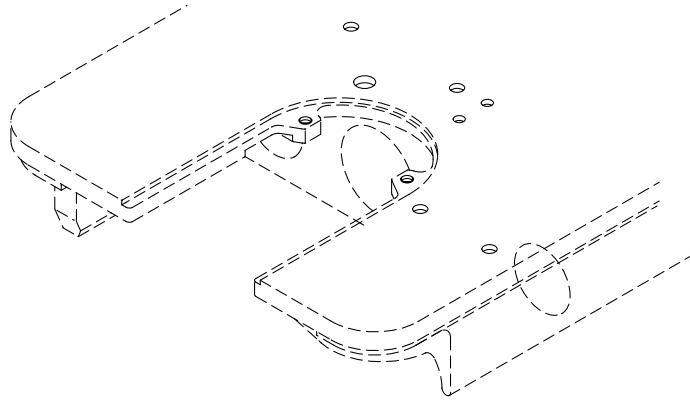

Anschluß siehe Seite 4-5
 For connection see page 4-5
 Raccord, cf. page 4-5
 Para la conexión, véase la pág. 4-5

Anschluß siehe Seite 9-2
 For connection see page 9-2
 Raccord, cf. page 9-2
 Para la conexión, véase la pág. 9-2

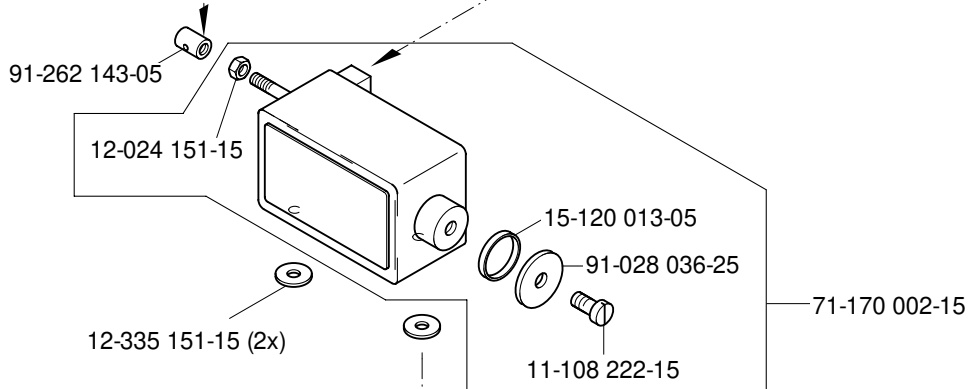

siehe Seite 3-1
 see page 3-1
 voir page 3-1
 véase la página 3-1

11-210 168-15 (2x)

Fadenabschneid-Einrichtung (-900/24) PFAFF 1051
 Thread trimmer (-900/24) PFAFF 1053
 Coupe-fil (-900/24) PFAFF 1181
 Cortahilos (-900/24) PFAFF 1183

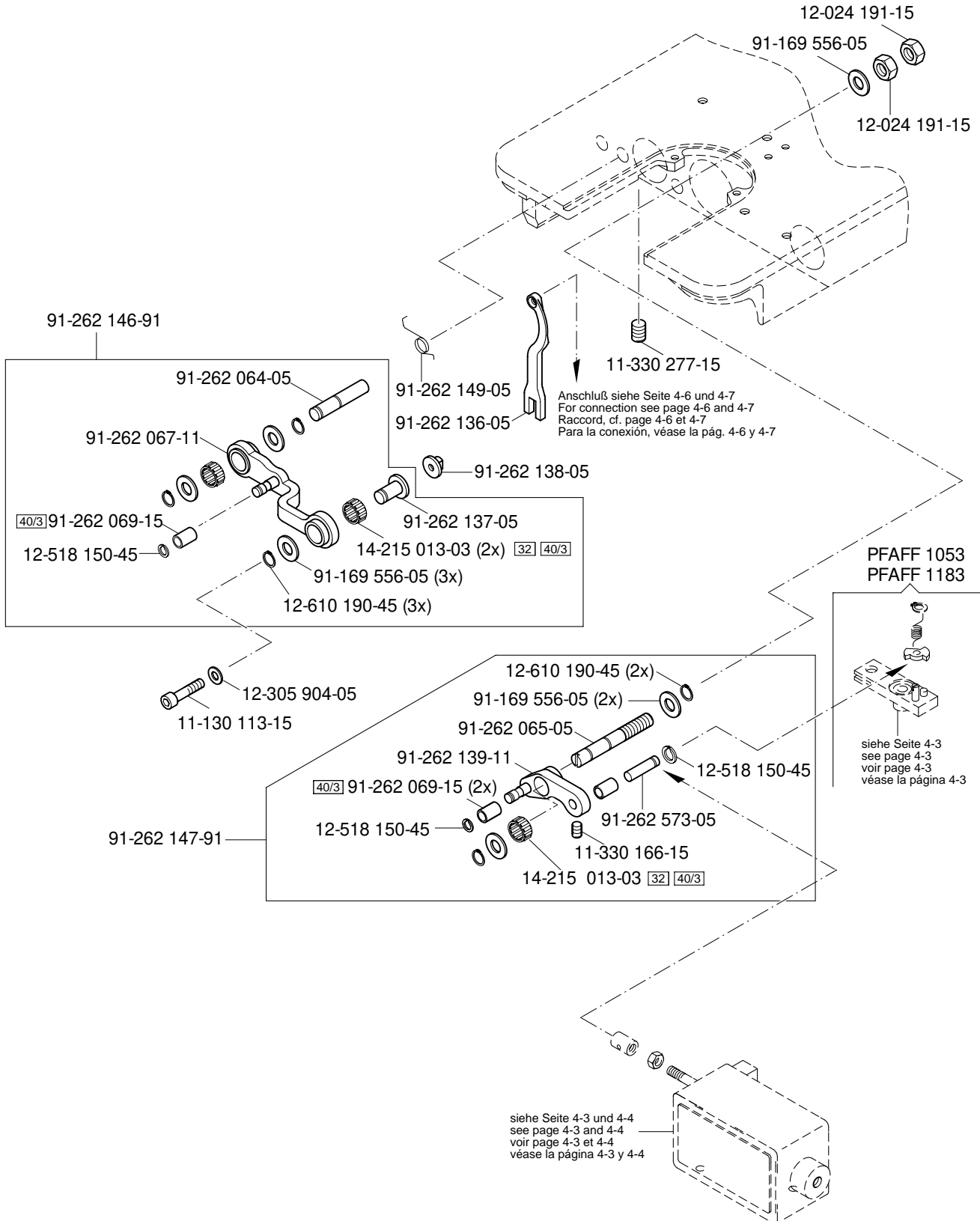
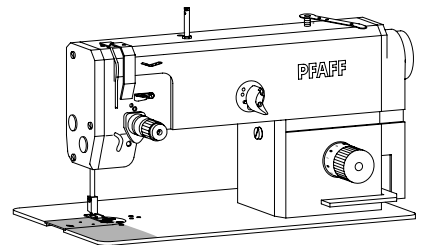

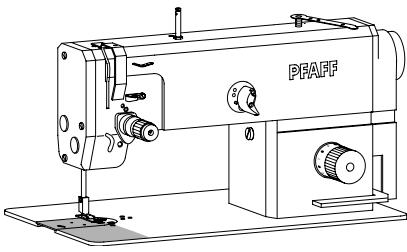

Fadenabschneid-Einrichtung (-900/24)
 Thread trimmer (-900/24)
 Coupe-fil (-900/24)
 Cortahilos (-900/24)

PFAFF 1051
 PFAFF 1053

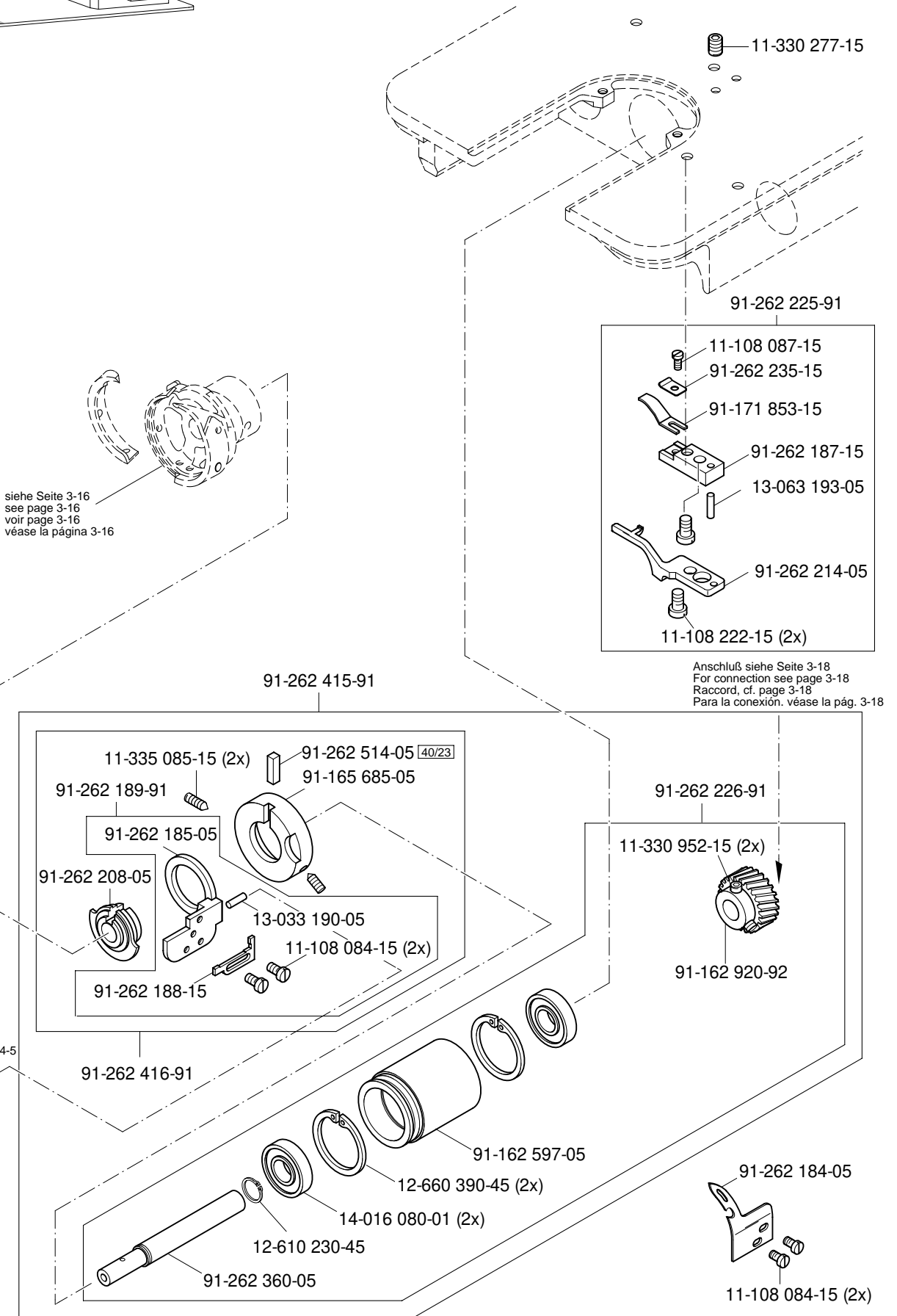

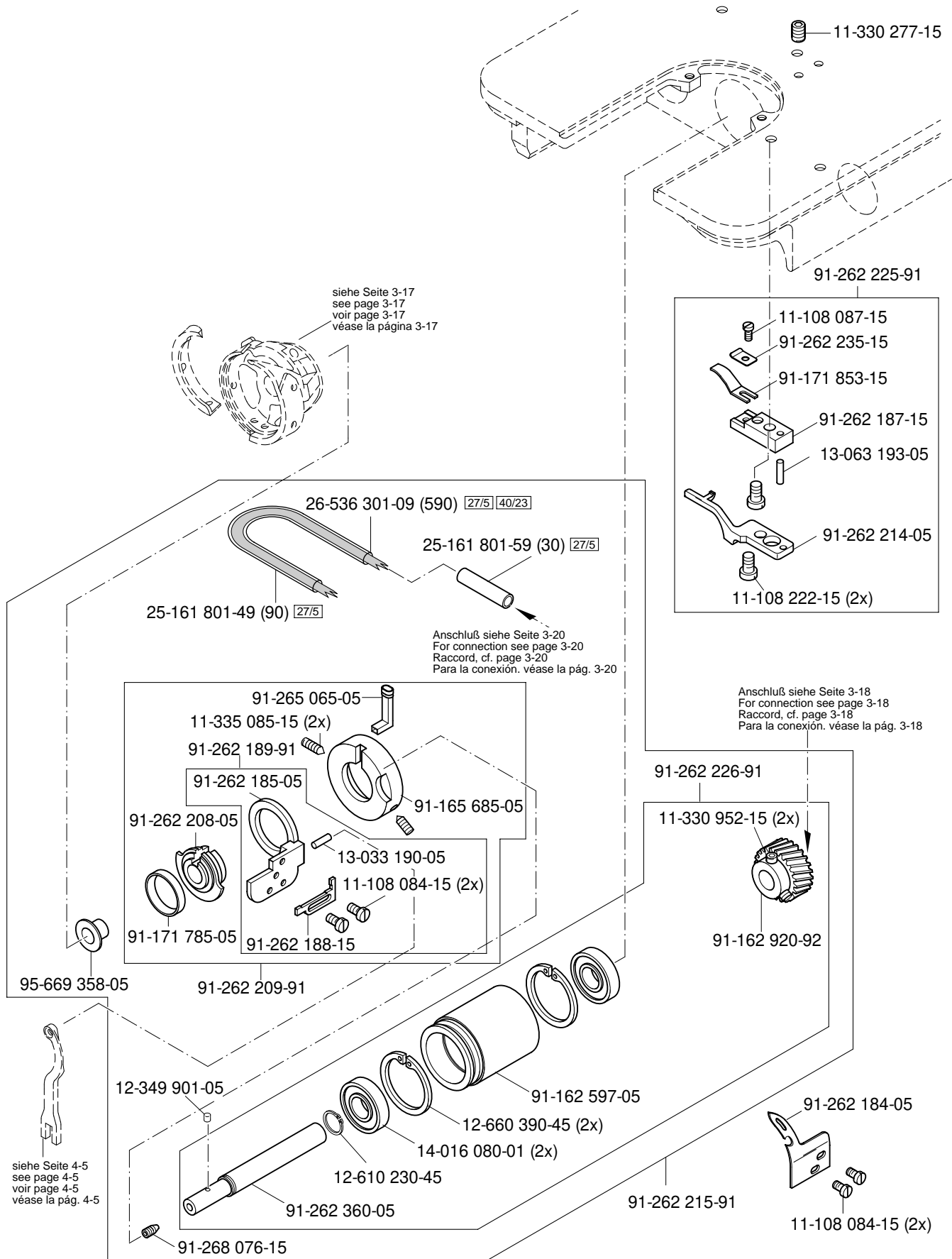
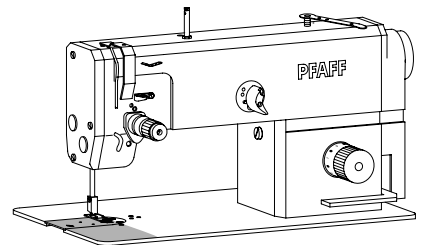

siehe Seite 4-5
 see page 4-5
 voir page 4-5
 véase la pág. 4-5

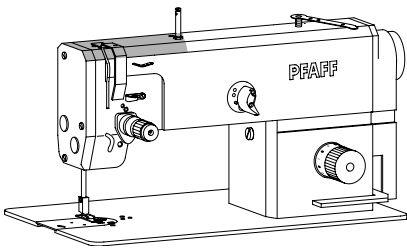

Fadenabstreif-Einrichtung (-909/04)
 Thread wiper (-909/04)
 Racleur de fil (-909/04)
 Retirahilos (-909/04)

PFAFF 1051-900/24
 PFAFF 1053-900/24
 PFAFF 1181-900/24
 PFAFF 1183-900/24

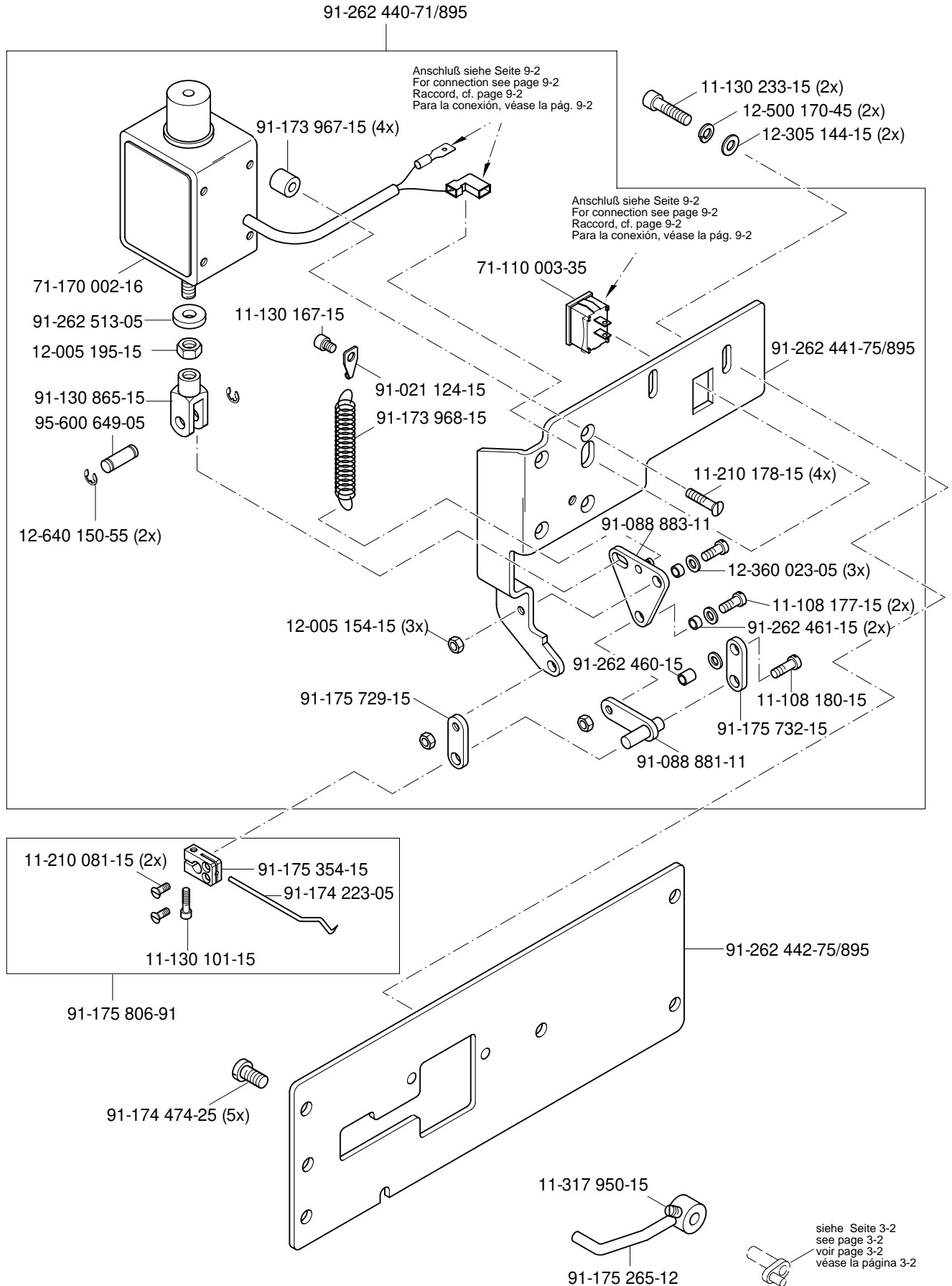

Presserfuß-Automatik (-910/06)
 Automatic presser foot lifter (-910/06)
 Relève-pied automatique (-910/06)
 Alzaprensatelas (-910/06)

PFAFF 1051-900/24
 PFAFF 1053-900/24
 PFAFF 1181-900/24
 PFAFF 1183-900/24

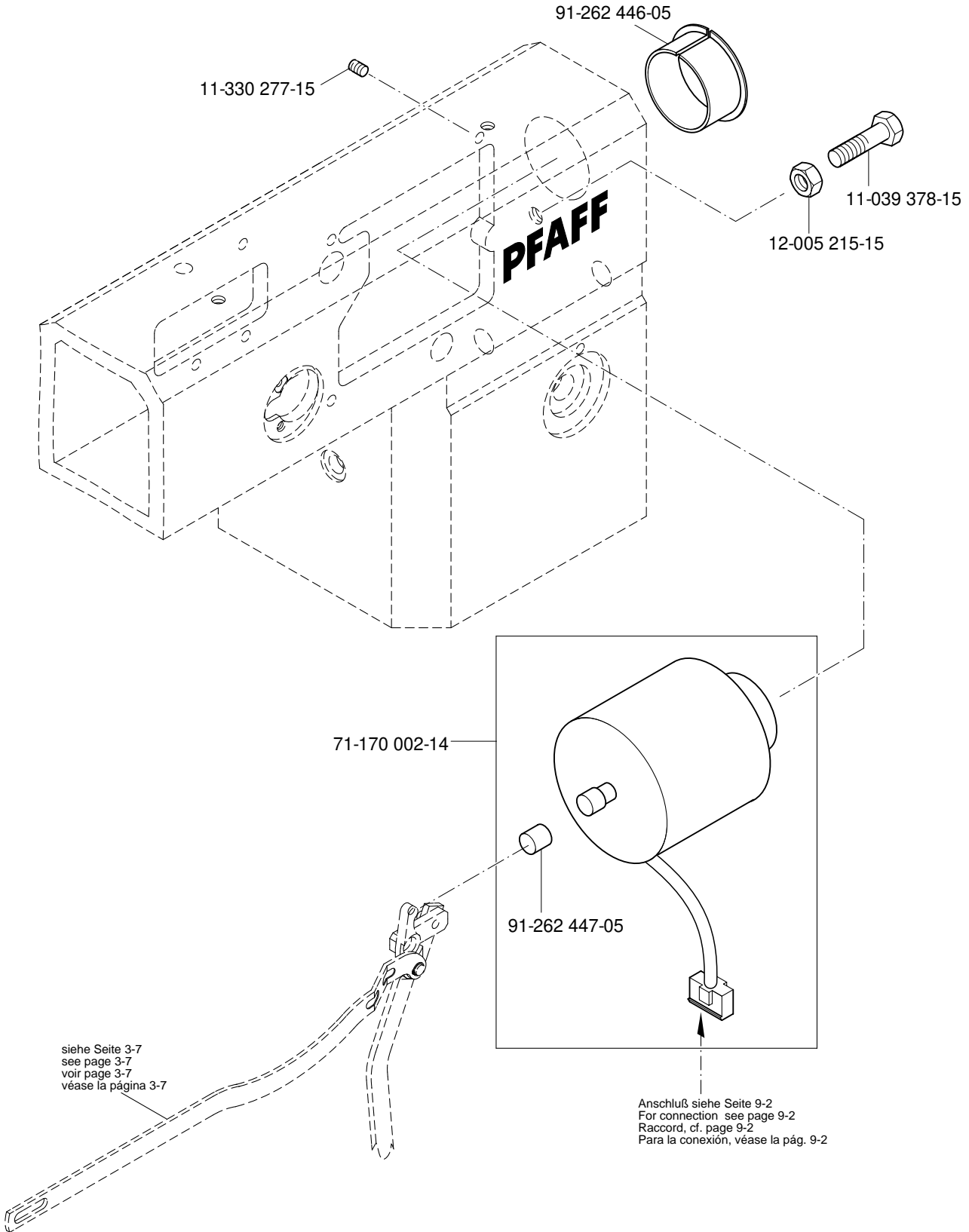
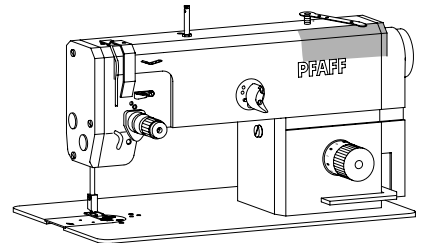

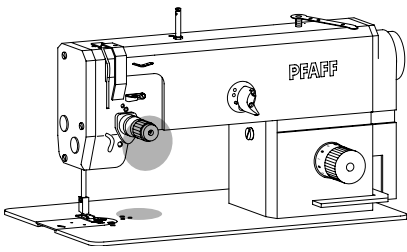

Verriegelungs-Einrichtung (-911/37)
 Backtacking mechanism (-911/37)
 Dispositif à points d'arrêt (-911/37)
 Rematador (-911/37)

PFAFF 1051-900/24
 PFAFF 1053-900/24
 PFAFF 1181-900/24
 PFAFF 1183-900/24

Anschluß siehe Seite 9-2
 For connection see page 9-2
 Raccord, cf. page 9-2
 Para la conexión, véase la pág. 9-2

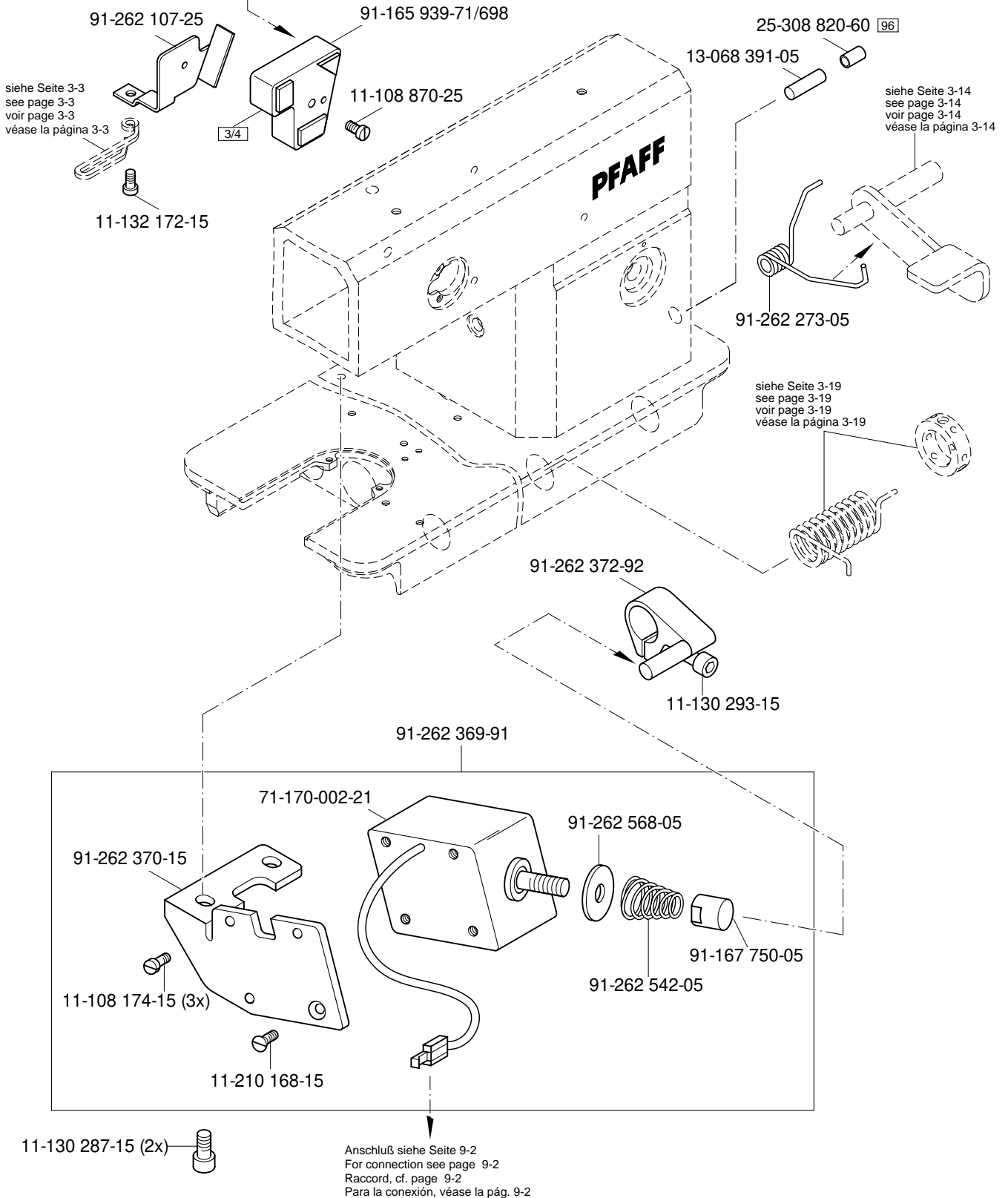

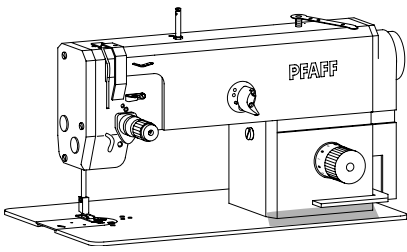

Einbaumotor	PFAFF 1051-900/24
Built-in motor	PFAFF 1053-900/24
Moteur incorporé	PFAFF 1181-900/24
Motor incorporado	PFAFF 1183-900/24

9.01

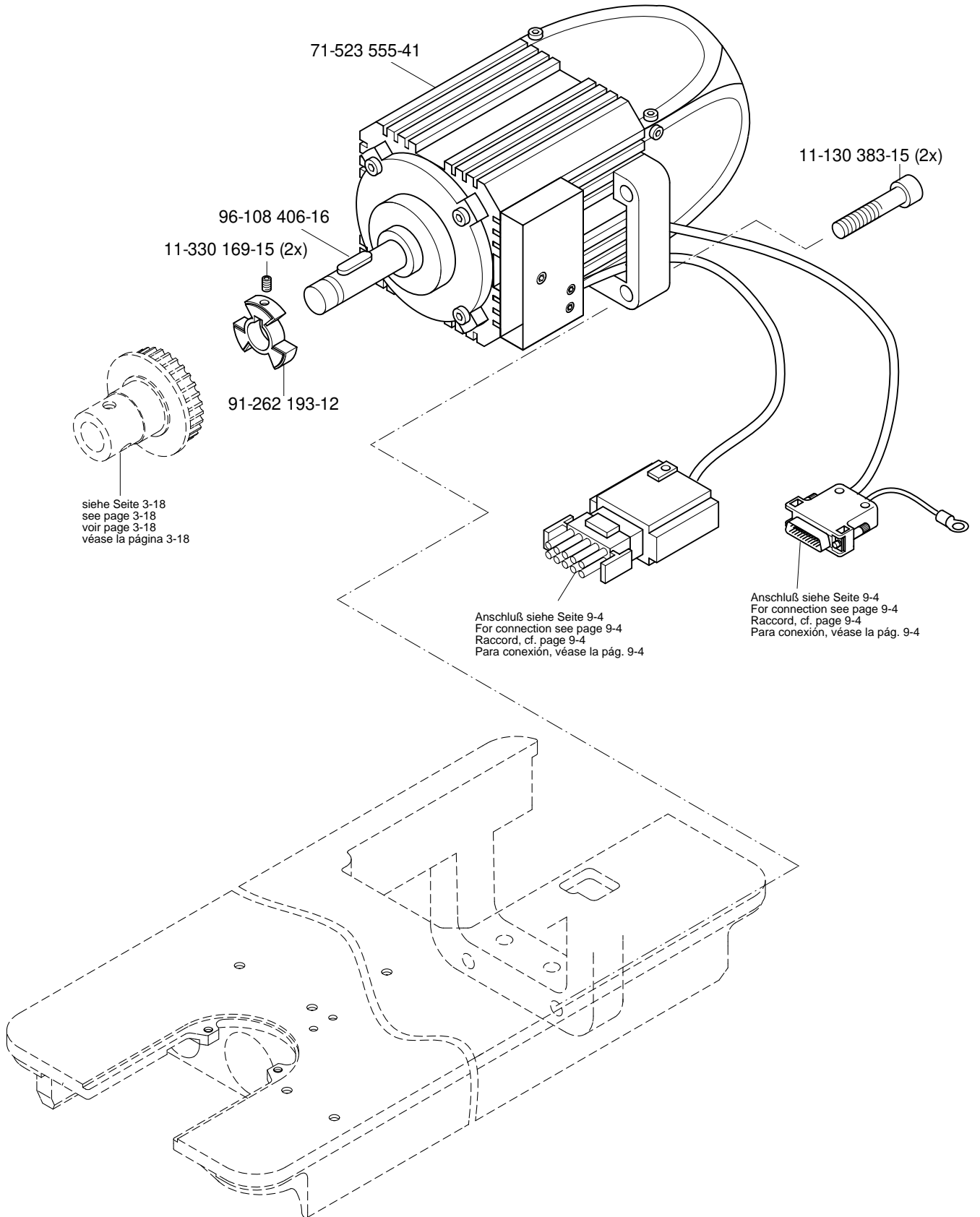

9.02

Kabelbaum zum Oberteil
 Cable tree to sewing head
 Faisceau de câbles vers la tête de mach.
 Mazo de cables para el cabezal

PFAFF 1051-900/24
 PFAFF 1053-900/24
 PFAFF 1181-900/24
 PFAFF 1183-900/24

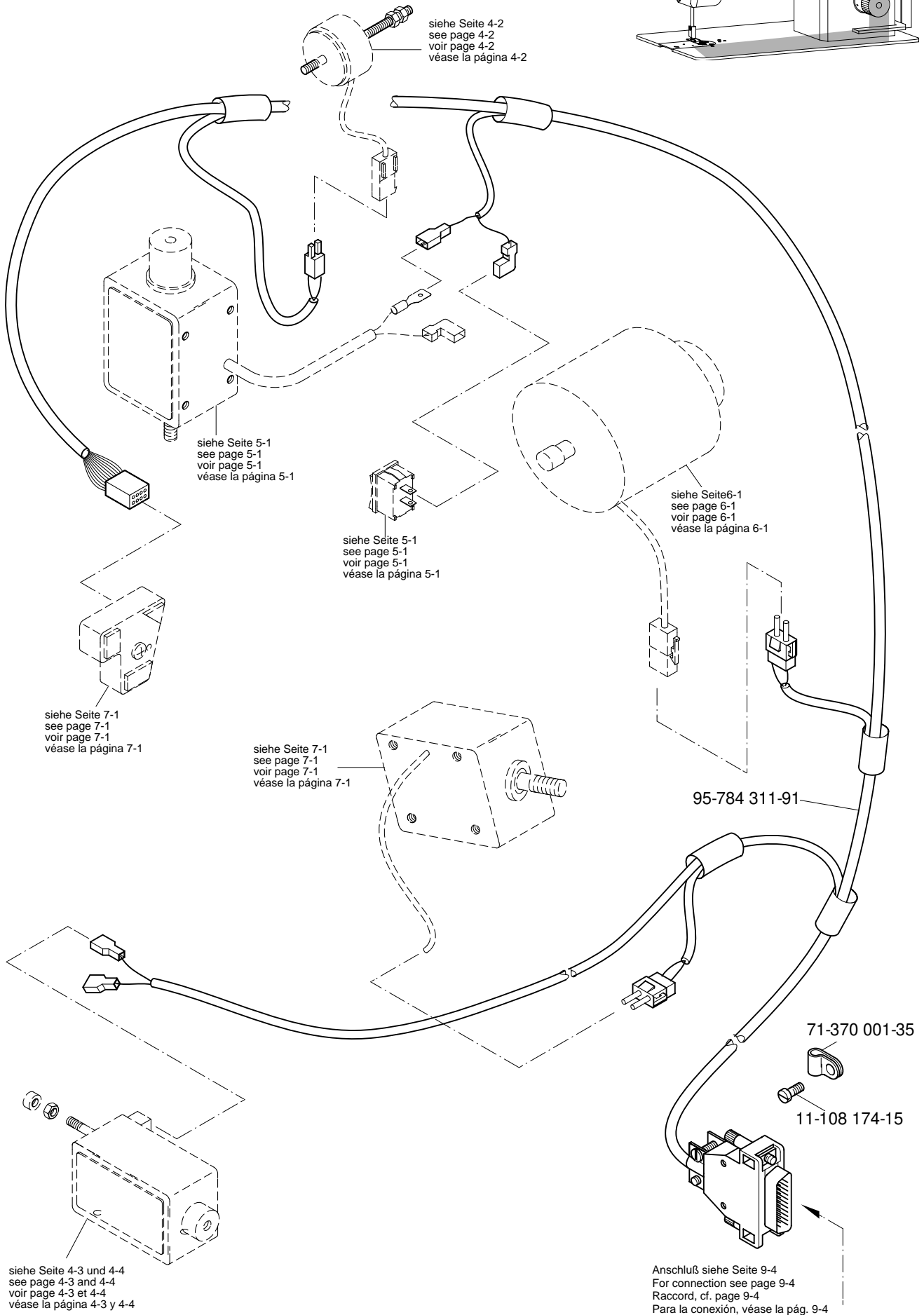
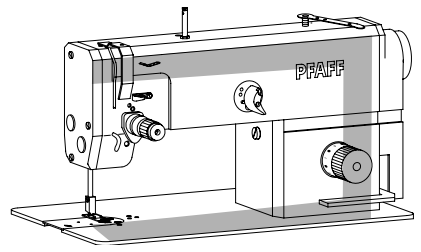

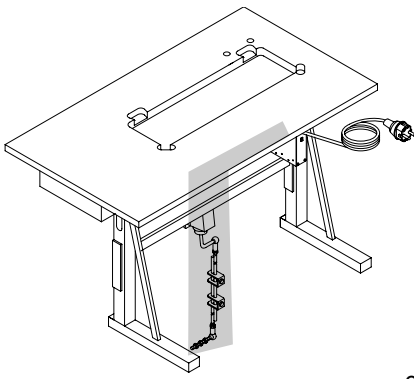

Sollwertgeber PFAFF 1051
 Set-point generator PFAFF 1053
 Codeur PFAFF 1181
 Emisor del valor teórico PFAFF 1183

9.03

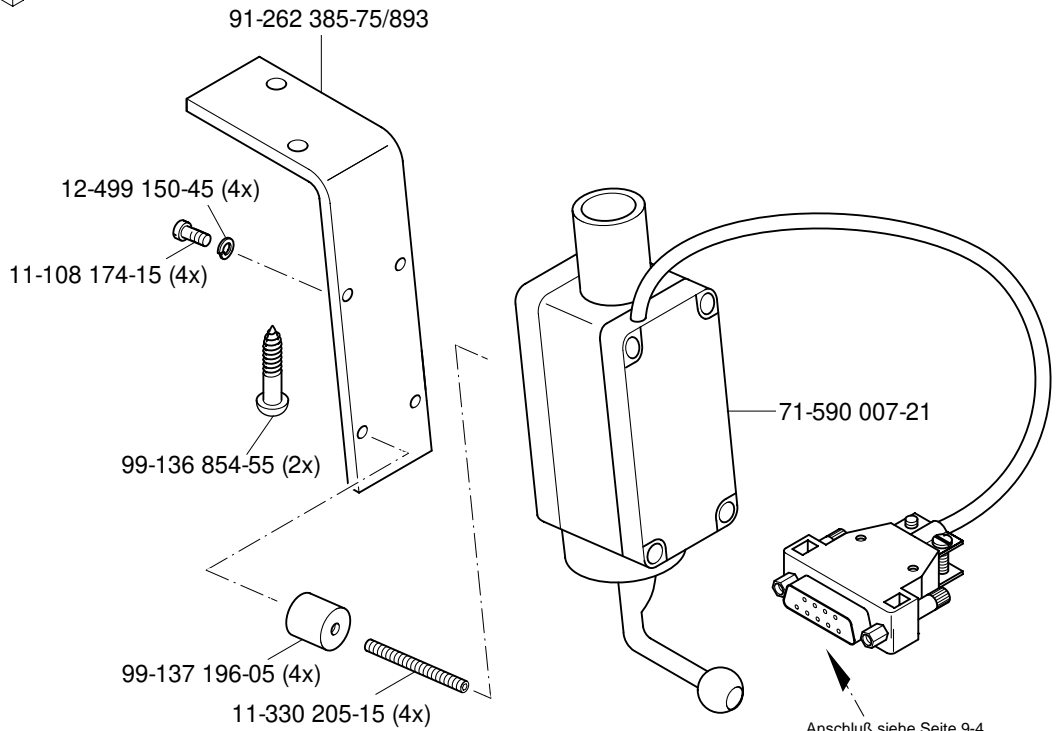

Anschluß siehe Seite 9-4
 For connection see page 9-4
 Raccordo, cf. page 12-4 et 9-4
 Para la conexión, véase la pág. 9-4

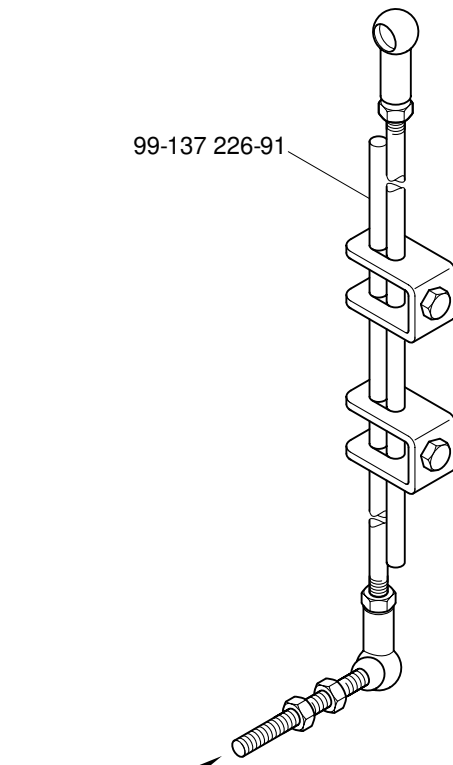

Zur Tretplatte
 For the pedal
 Pour la pédale
 Para el pedal

9.04

Steuerkasten

Control box

Boîtier de contrôle

Caja de mandos

PFAFF 1051-900/24

PFAFF 1053-900/24

PFAFF 1181-900/24

PFAFF 1183-900/24

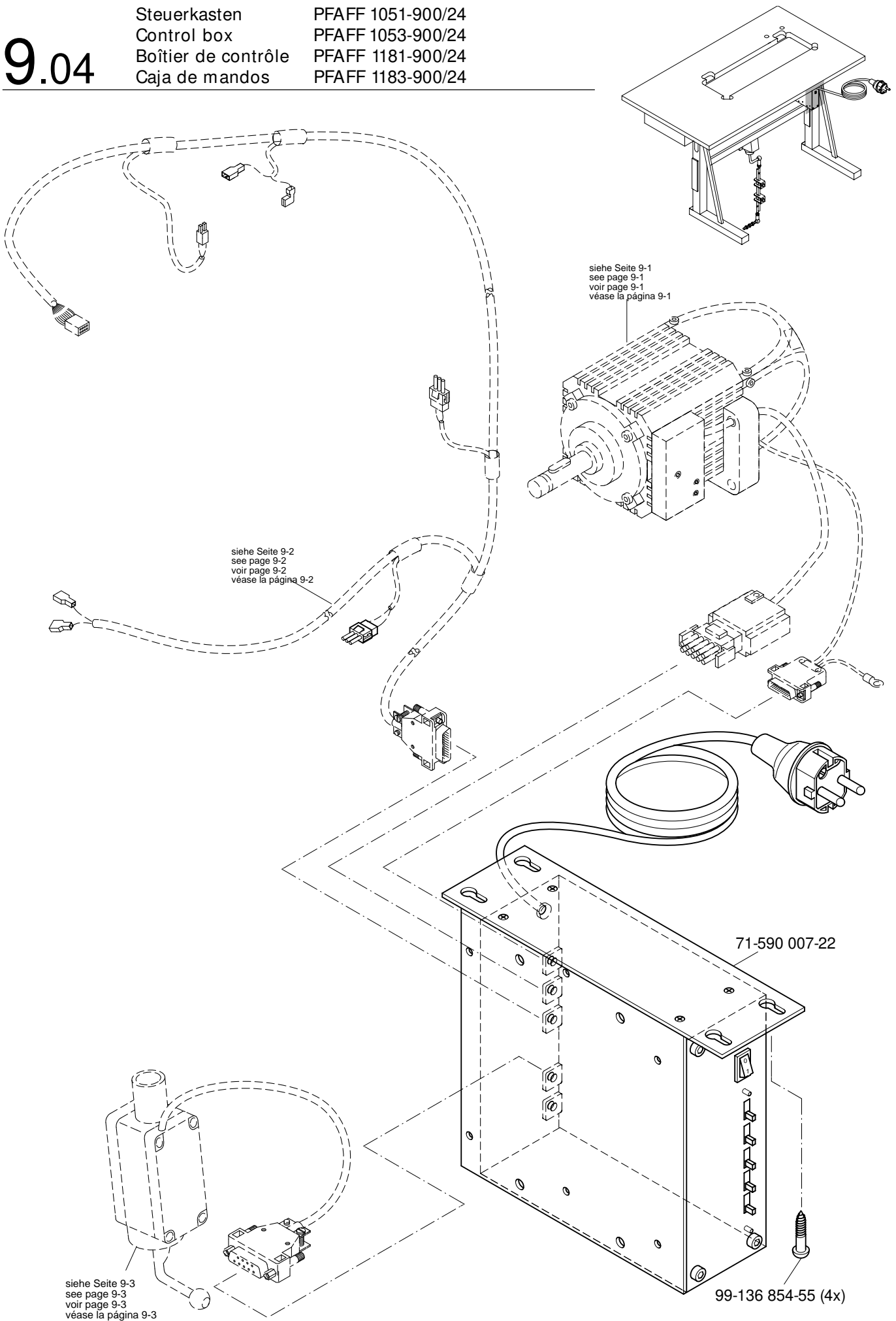

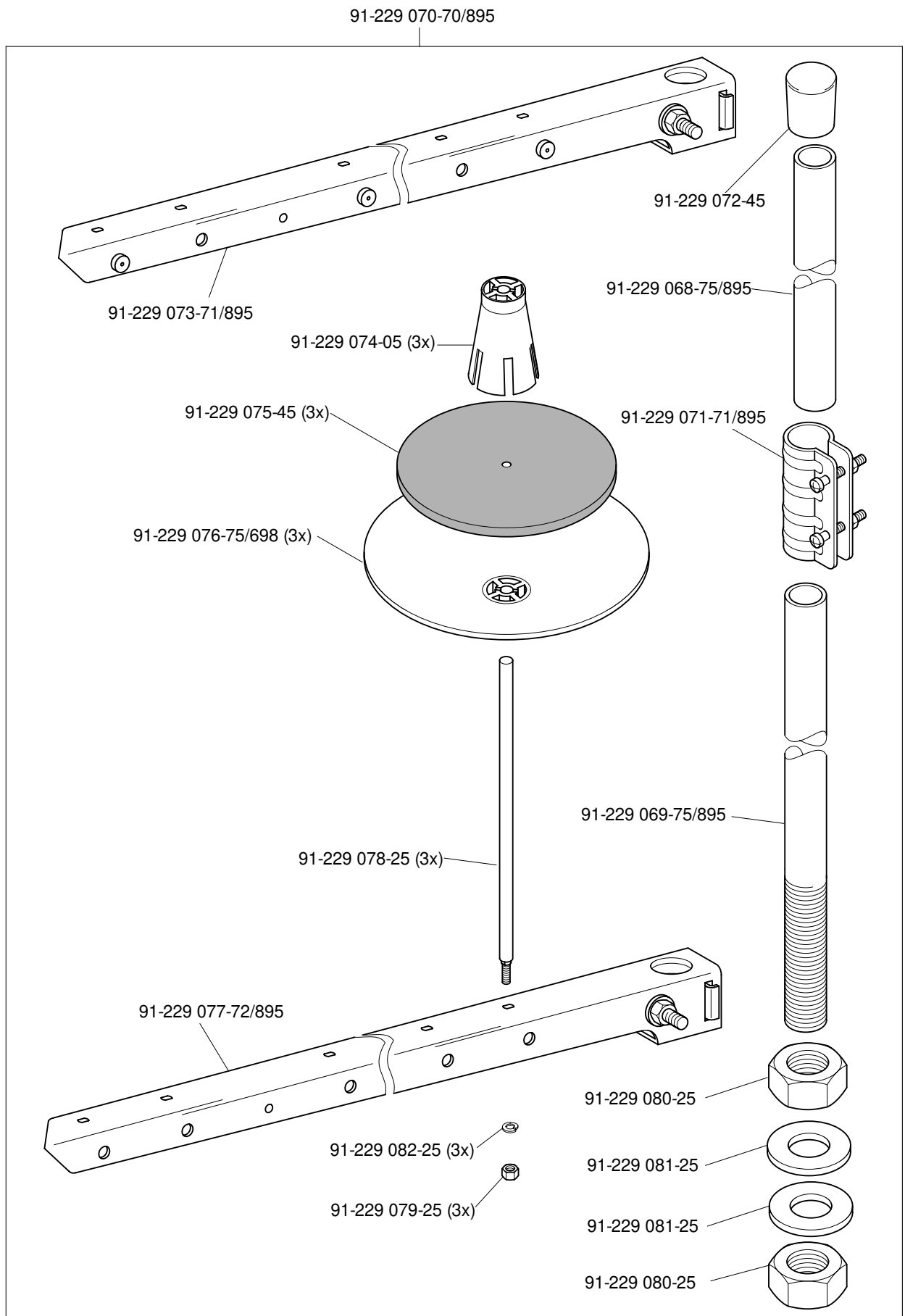

11

Einstellehren	PFAFF 1051
Adjustment gauges	PFAFF 1053
Calibres	PFAFF 1181
Calibres de ajuste	PFAFF 1183

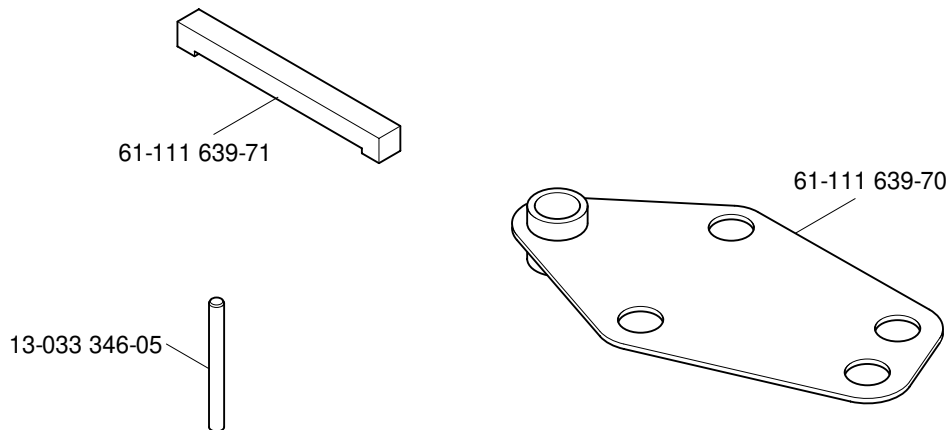

12

Teile zur Tischplatte	PFAFF 1051
Parts for table top	PFAFF 1053
Pièces du plateau	PFAFF 1181
Piezas para el tablero	PFAFF 1183

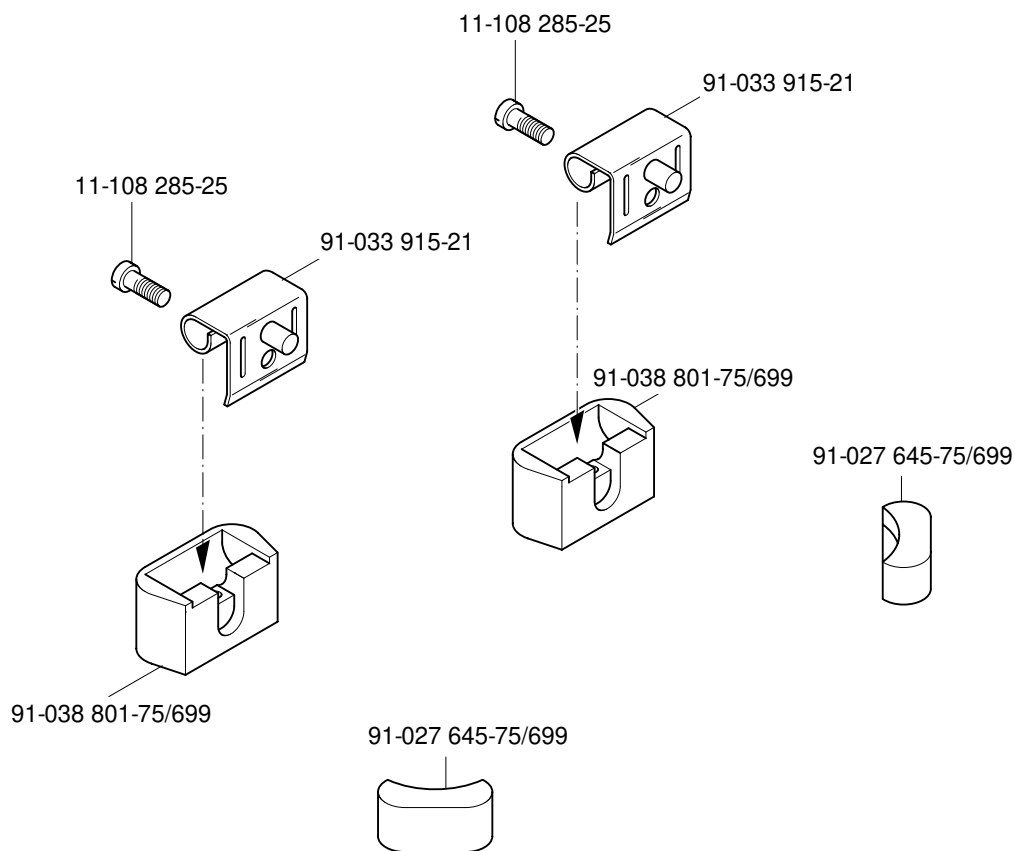

Keilriemen	PFAFF 1051
V-belt	PFAFF 1053
Courroie trapézoïdale	PFAFF 1181
Correa trapezoidal	PFAFF 1183

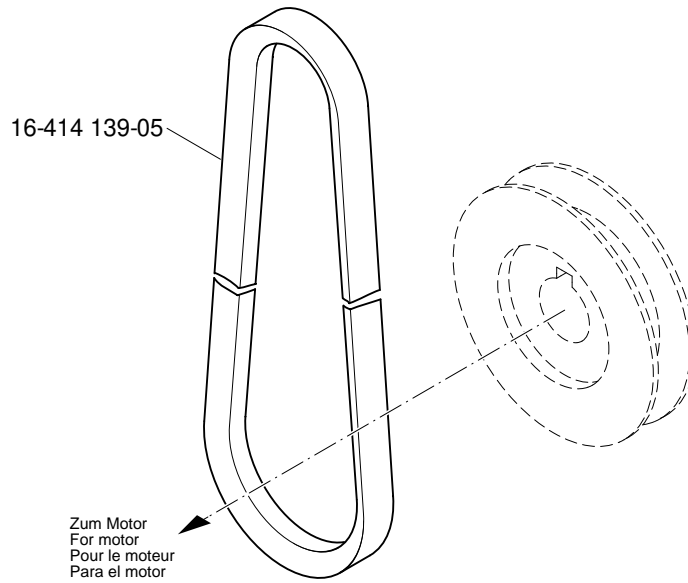

Knieüferteile	PFAFF 1051
Knee lifter parts	PFAFF 1053
Pièces du releveur de genouillère	PFAFF 1181
Piezas del alzaprensateles por rodillera	PFAFF 1183

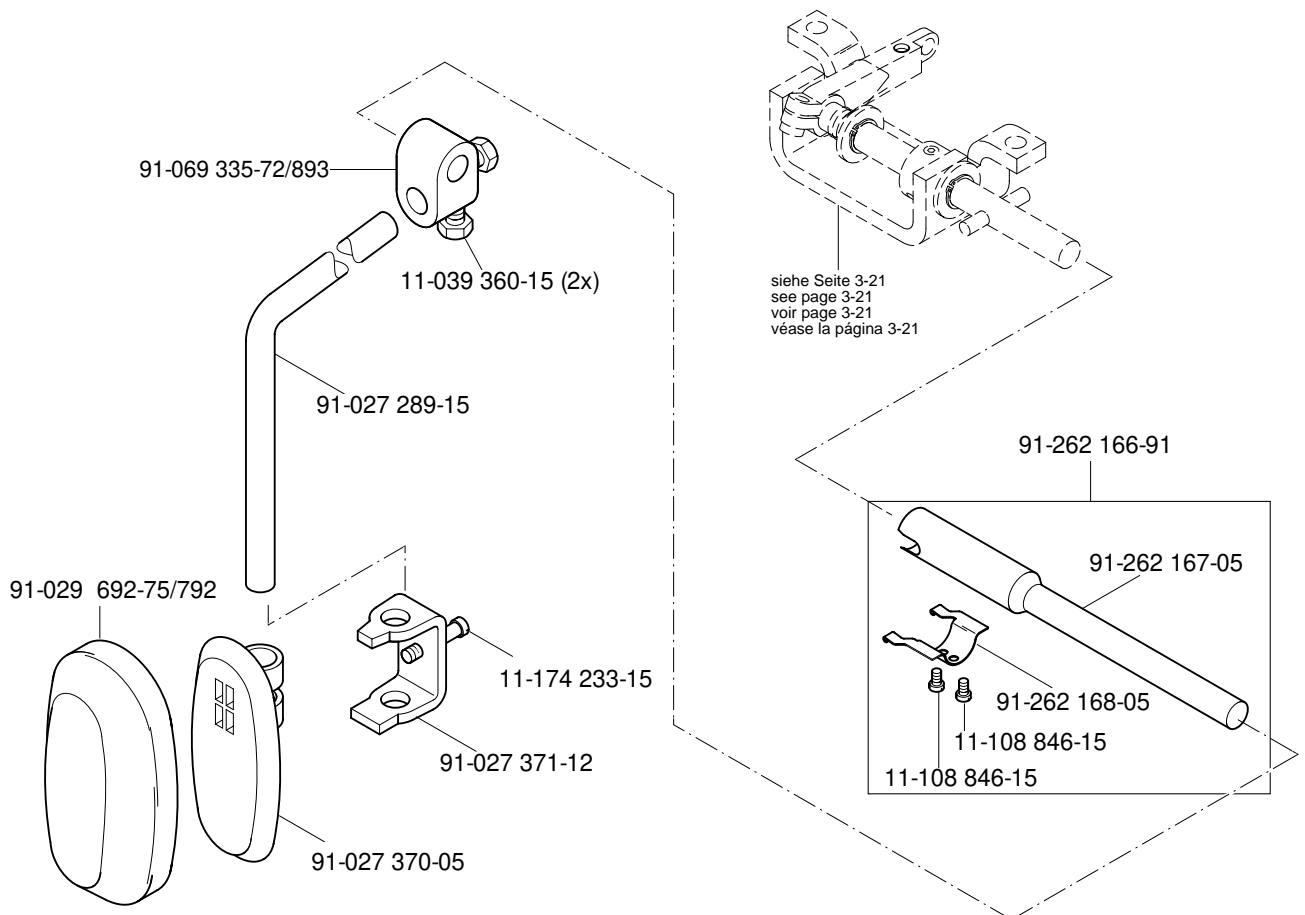

Öl Oil Huile Aceite	Mittelpunkts- Viskosität bei: Mean viscosity at: Viscosité moyenne à: Viscosidad media a:		Dichte bei: Density of: Densité à: Densidad a:		Bestellnummer für Behälter mit: Part number for can with: Numéro de commande pour récipients avec: Número de pedido para recipientes con:		
	°C	mm ² /s	°C	g/cm ³ (g/ml)	1 Liter 1 Litre 1 Litro	5 Liter 5 Litre 5 Litros	10 Liter 10 Litre 10 Litros
28-011 201-05	40	10,0	15	0,847	91-027 975-91	91-027 976-91	91-027 977-91

Fett Grease Graisse Grasa	Penetration Penetration Pénétration Penetración	Tropfpunkt Drip-point Point de suintement Punto de goteo	Bestellnummer für Behälter mit: Part number for can with: Numéro de commande pour récipients avec: Número de pedido para recipientes con:		
			mm/10	°C	0,25 kg
28-011 202-05					28-011 202-05
28-011 202-43	375-405	150			28-011 202-43
28-011 202-47	220-250	185			28-011 202-47

Reinigungsmittel Cleansing agent Agents de nettoyage Limpiadores			Bestellnummer für Behälter mit: Part number for can with: Numéro de commande pour récipients avec: Número de pedido para recipientes con:	
			240 ml	
95-665 735-91 Isopropyl-Alkohol			95-665 735-91	

No.	Seite Page Pages Página	No.	Seite Page Pages Página	No.	Seite Page Pages Página	No.	Seite Page Pages Página
11-039 360-15	13- 1	11-130 395-15	3- 21	11-330 952-15	3- 2, 3- 9, 3- 10, 3- 11, 3- 15, 3- 16, 3- 17, 3- 18, 4- 1, 4- 2, 4- 6, 4- 7	12-360 064-05	3- 3
11-039 378-15	6- 1	11-130 557-15	3- 21	11-330 955-15	3- 4, 3- 5, 3- 18	12-360 083-05	3- 14
11-106 260-15	3- 1	11-130 581-15	3- 21	11-330 962-15	3- 15	12-360 143-05	3- 9, 3- 13
11-108 084-15	4- 6, 4- 7	11-132 172-15	3- 3, 7- 1	11-330 964-15	3- 8, 3- 18	12-499 150-45	9- 3
11-108 087-15	4- 6, 4- 7	11-132 223-15	3- 2	11-330 968-15	3- 18	12-499 170-45	5- 1
11-108 171-15	8- 1	11-170 281-15	3- 7, 4- 2	11-335 085-15	4- 6, 4- 7	12-510 171-45	3- 14
11-108 174-15	7- 1, 9- 2, 9- 3	11-173 168-25	3- 3	11-335 280-15	3- 8, 3- 13, 3- 14, 3- 18	12-518 150-45	4- 5
11-108 174-25	3- 2	11-173 171-25	3- 1	11-341 277-15	3- 2, 3- 4, 3- 5, 3- 6	12-518 280-45	3- 19
11-108 177-15	3- 20, 5- 1	11-174 233-15	13- 1	11-341 901-15	3- 4, 3- 5	12-610 190-45	3- 7, 3- 9, 3- 15, 3- 18, 3- 19, 3- 21, 4- 3, 4- 5
11-108 180-15	5- 1	11-178 223-25	3- 12	11-341 902-15	3- 18	12-610 200-45	3- 13
11-108 222-15	3- 16, 3- 17, 4- 3, 4- 4, 4- 6, 4- 7	11-210 081-15	5- 1	12-005 154-15	4- 2, 5- 1	12-610 210-45	3- 3
11-108 222-25	3- 1	11-210 168-15	4- 3, 4- 4, 7- 1	12-005 175-05	3- 13	12-610 230-45	3- 16, 3- 17, 3- 21, 4- 6, 4- 7
11-108 225-15	3- 1, 3- 18	11-210 168-25	3- 10	12-005 195-15	5- 1	12-610 250-45	3- 18
11-108 228-15	3- 1	11-210 178-15	5- 1	12-005 215-15	6- 1	12-610 280-45	3- 19
11-108 285-15	3- 1	11-210 265-15	3- 8	12-024 151-15	4- 3, 4- 4	12-618 120-45	4- 3
11-108 285-25	3- 14, 11- 1	11-225 223-15	3- 3	12-024 171-15	3- 21	12-618 210-45	3- 14
11-108 846-15	13- 1	11-225 232-15	3- 2	12-024 191-15	4- 5	12-624 200-45	4- 1, 4- 2
11-108 870-25	7- 1	11-250 084-25	3- 10	12-024 191-25	3- 10	12-624 210-45	3- 2
11-130 086-15	4- 2	11-305 226-15	3- 21	12-024 210-15	8- 1	12-624 280-45	3- 9
11-130 101-15	5- 1	11-317 950-15	3- 15, 5- 1	12-024 210-15	8- 1	12-624 310-45	3- 19
11-130 113-15	4- 5	11-317 971-15	3- 4, 3- 5	12-305 114-15	3- 6, 8- 1	12-640 130-55	3- 2, 3- 10
11-130 167-15	5- 1	11-320 171-15	3- 12	12-305 144-15	5- 1	12-640 150-55	3- 7, 3- 12, 5- 1
11-130 173-15	3- 1	11-330 166-15	3- 9, 4- 5	12-305 264-15	3- 21	12-640 170-55	3- 12
11-130 176-15	3- 6, 3- 15, 8- 1	11-330 169-15	9- 1	12-305 904-05	4- 5	12-640 200-55	3- 11
11-130 194-15	3- 1	11-330 175-15	3- 2, 4- 1, 4- 2	12-335 151-15	4- 3, 4- 4	12-650 008-55	3- 1
11-130 224-15	3- 9, 3- 11, 3- 13, 3- 18, 3- 21	11-330 205-15	9- 3	12-335 171-15	3- 13	12-660 390-45	3- 16, 3- 17, 4- 6, 4- 7
11-130 233-15	5- 1	11-330 220-15	3- 2, 3- 3, 3- 4, 3- 5, 3- 6	12-341 090-25	3- 11	12-710 230-12	3- 21
11-130 284-15	3- 15	11-330 226-15	4- 1, 4- 2	12-349 901-05	3- 17, 4- 7	12-710 901-22	3- 12
11-130 287-15	3- 1, 3- 9, 3- 13, 3- 19, 3- 21, 4- 3, 7- 1	11-330 277-15	3- 8, 3- 9, 3- 11, 3- 12, 3- 14, 3- 16, 3- 17, 3- 19, 4- 5, 4- 6, 4- 7, 6- 1	12-360 023-05	5- 1	13-030 341-05	3- 1
11-130 293-15	7- 1	11-330 280-15	3- 8	12-360 054-05	3- 13	13-033 190-05	4- 6, 4- 7
11-130 383-15	9- 1			12-360 063-05	3- 11, 3- 12	13-033 208-05	3- 11

No.	Seite Page Pages Página	No.	Seite Page Pages Página	No.	Seite Page Pages Página	No.	Seite Page Pages Página
13-033 346-05	11 - 1	28-011 202-43	15 - 1	91-056 198-21	4 - 1, 4 - 2	91-130 865-15	5 - 1
13-052 085-55	3 - 8, 3 - 9	28-011 202-47	15 - 1	91-056 578-91	3 - 10	91-161 334-25	3 - 3
13-052 142-05	3 - 4, 3 - 5	61-111 639-70	11 - 1	91-056 760-05	4 - 1, 4 - 2	91-162 578-71/698	3 - 1
13-052 196-15	3 - 4, 3 - 5	61-111 639-71	11 - 1	91-069 056-05	3 - 4, 3 - 6	91-162 582-75/895	3 - 1
13-063 193-05	3 - 16, 3 - 17, 4 - 6, 4 - 7	71-110 003-35	5 - 1	91-069 075-01	3 - 2	91-162 583-75/699	3 - 1
13-064 247-05	3 - 2	71-170 002-14	6 - 1	91-069 079-72/895	3 - 2	91-162 596-25	3 - 3
13-068 391-05	7 - 1	71-170 002-15	4 - 3, 4 - 4	91-069 105-25	3 - 3	91-162 597-05	3 - 16, 3 - 17, 4 - 6, 4 - 7
13-250 088-25	3 - 4, 3 - 5	71-170 002-16	5 - 1	91-069 322-01	3 - 2	91-162 690-92	3 - 2
13-250 097-25	3 - 6, 3 - 7	71-170 002-20	4 - 2	91-069 335-72/893	13 - 1	91-162 694-05	3 - 2
14-010 172-01	3 - 9, 3 - 18	71-170 002-21	7 - 1	91-069 554-92	3 - 15	91-162 920-92	3 - 16, 3 - 17, 4 - 6, 4 - 7
14-016 080-01	3 - 16, 3 - 17, 4 - 6, 4 - 7	71-370 001-35	9 - 2	91-069 562-05	3 - 2	91-162 921-92	3 - 18
14-016 151-91	3 - 8	71-523 555-41	9 - 1	91-069 579-05	3 - 2	91-165 685-05	4 - 6, 4 - 7
14-016 171-91	3 - 18	71-590 007-21	9 - 3	91-069 585-25	3 - 10	91-165 939-71/698	7 - 1
14-018 624-01	3 - 8	71-590 007-22	9 - 4	91-069 709-12	3 - 4, 3 - 5	91-166 452-21	3 - 10
14-018 624-91	3 - 18	91-000 422-25	3 - 15	91-069 712-05	3 - 4, 3 - 5	91-167 590-15	3 - 1
14-026 902-01	3 - 8	91-009 035-25	3 - 2	91-069 713-01	3 - 4, 3 - 5	91-167 750-05	7 - 1
14-215 013-03	3 - 9, 3 - 18, 4 - 5	91-021 124-15	5 - 1	91-069 735-07	3 - 9	91-168 024-07	3 - 11, 3 - 12
14-215 028-03	3 - 4, 3 - 5	91-027 289-15	13 - 1	91-088 881-11	5 - 1	91-168 025-05	3 - 3
14-215 031-03	3 - 3	91-027 370-05	13 - 1	91-088 883-11	5 - 1	91-168 341-07	3 - 14
14-215 121-13	3 - 19	91-027 371-12	13 - 1	91-100 117-15	3 - 2	91-168 347-05	3 - 19
14-215 908-03	3 - 13	91-027 645-75/699	11 - 1	91-100 270-25	3 - 11	91-168 480-15	3 - 8
14-602 901-01	3 - 10	91-027 975-91	15 - 1	91-100 281-25	3 - 10	91-168 833-07	3 - 19
15-120 013-05	4 - 3, 4 - 4	91-027 976-91	15 - 1	91-100 331-15	3 - 7	91-169 457-12	3 - 4, 3 - 5
16-414 139-05	13 - 1	91-027 977-91	15 - 1	91-100 400-15	3 - 8	91-169 556-05	3 - 7, 3 - 9, 3 - 15, 3 - 18, 4 - 5
16-479 081-05	4 - 1	91-028 036-25	4 - 3, 4 - 4	91-105 482-05	3 - 11	91-171 042-05	3 - 10
25-161 801-49	3 - 5, 3 - 6, 3 - 17, 4 - 7	91-029 692-75/792	13 - 1	91-118 099-91/001	3 - 10	91-171 049-05	3 - 10
25-161 801-52	3 - 5, 3 - 6	91-033 765-15	3 - 19	91-118 570-92	3 - 8	91-171 050-05	3 - 2
25-161 801-59	3 - 17, 4 - 7	91-033 915-21	11 - 1	91-118 681-05	3 - 10	91-171 068-05	3 - 2
25-308 820-60	7 - 1	91-038 801-75/699	11 - 1	91-118 683-05	3 - 10	91-171 158-92	3 - 18
26-536 301-09	3 - 4, 3 - 5, 3 - 6, 3 - 17, 4 - 7	91-056 192-25	3 - 10, 4 - 1, 4 - 2	91-118 685-05	3 - 10	91-171 205-07	3 - 19
28-011 201-05	15 - 1	91-056 193-25	3 - 10, 4 - 1, 4 - 2	91-118 711-05	3 - 15	91-171 229-05	3 - 18
28-011 202-05	15 - 1	91-056 197-91	4 - 1, 4 - 2	91-118 940-05	3 - 10	91-171 409-12	3 - 19

No.	Seite Page Pages Página	No.	Seite Page Pages Página	No.	Seite Page Pages Página	No.	Seite Page Pages Página
91-171 441-01	3-9	91-229 077-72/895	10-1	91-262 148-05	4-1	91-262 194-92	3-18
91-171 785-05	4-7	91-229 078-25	10-1	91-262 149-05	4-5	91-262 195-92	3-8
91-171 811-05	3-7	91-229 079-25	10-1	91-262 150-91	3-18	91-262 196-05	3-8
91-171 853-15	4-6,4-7	91-229 080-25	10-1	91-262 151-05	3-9,3-18	91-262 197-05	3-11
91-173 967-15	5-1	91-229 081-25	10-1	91-262 152-15	3-9,3-18	91-262 200-91	3-11
91-173 968-15	5-1	91-229 082-25	10-1	91-262 153-92	3-18	91-262 201-05	3-11
91-174 016-05	3-6	91-262 060-91	4-1	91-262 154-92	3-18	91-262 202-15	3-11
91-174 223-05	5-1	91-262 061-05	3-18	91-262 155-92	3-18	91-262 203-05	3-11
91-174 474-25	5-1	91-262 062-92	3-18	91-262 156-91	3-19	91-262 208-05	4-6,4-7
91-174 552-05	3-4,3-5	91-262 064-05	4-5	91-262 157-05	3-19	91-262 209-91	4-7
91-174 553-05	3-4,3-5	91-262 065-05	4-5	91-262 158-05	3-19	91-262 210-92	3-12
91-174 783-05	3-10	91-262 067-11	4-5	91-262 161-72/698	3-8	91-262 214-05	3-16,3-17, 4-6,4-7
91-174 851-05	4-1,4-2	91-262 069-15	4-5	91-262 162-75/698	3-1	91-262 215-91	4-7
91-174 860-05	4-3	91-262 073-91	3-3	91-262 163-05	3-21	91-262 218-05	3-12
91-174 861-05	4-3	91-262 078-01	3-3	91-262 164-02	3-21	91-262 219-91	3-12
91-174 879-05	3-10	91-262 080-05	3-3	91-262 166-91	13-1	91-262 222-05	3-12
91-175 203-05	3-19	91-262 082-92	3-3	91-262 167-05	13-1	91-262 225-91	4-6,4-7
91-175 265-12	5-1	91-262 083-01	3-8	91-262 168-05	13-1	91-262 226-91	3-16,3-17, 4-6,4-7
91-175 354-15	5-1	91-262 083-92	3-8	91-262 170-05	3-21	91-262 228-01	3-20
91-175 557-01	4-1,4-2	91-262 086-05	3-3	91-262 172-92	3-21	91-262 231-72/893	3-14
91-175 729-15	5-1	91-262 107-25	7-1	91-262 174-11	3-7	91-262 232-01	3-14
91-175 732-15	5-1	91-262 133-91	4-3	91-262 175-11	3-7	91-262 235-15	4-6,4-7
91-175 806-91	5-1	91-262 134-01	4-3	91-262 179-05	3-7	91-262 236-91	3-17
91-229 068-75/895	10-1	91-262 136-05	4-5	91-262 181-05	3-7	91-262 237-91	3-17
91-229 069-75/895	10-1	91-262 137-05	4-5	91-262 183-75/895	3-1	91-262 244-92	3-19
91-229 070-70/895	10-1	91-262 138-05	4-5	91-262 184-05	4-6,4-7	91-262 245-04	3-19
91-229 071-71/895	10-1	91-262 139-11	4-5	91-262 185-05	4-6,4-7	91-262 248-91	3-21
91-229 072-45	10-1	91-262 143-05	4-3,4-4	91-262 187-15	3-16,3-17, 4-6,4-7	91-262 250-91	3-17
91-229 073-71/895	10-1	91-262 144-05	4-1,4-2	91-262 188-15	4-6,4-7	91-262 273-05	7-1
91-229 074-05	10-1	91-262 145-05	4-1	91-262 189-91	4-6,4-7	91-262 274-05	3-14
91-229 075-45	10-1	91-262 146-91	4-5	91-262 190-91	3-7	91-262 277-05	3-15
91-229 076-75/698	10-1	91-262 147-91	4-5	91-262 193-12	9-1	91-262 278-11	3-12

No.	Seite Page Pages Página	No.	Seite Page Pages Página	No.	Seite Page Pages Página	No.	Seite Page Pages Página
91-262 300-91	3- 15	91-262 385-75/893	9- 3	91-262 540-05	3- 9	95-669 358-05	3- 17,4- 7
91-262 301-92	3- 15	91-262 408-05	8- 1	91-262 542-05	7- 1	95-784 311-91	9- 2
91-262 314-91	3- 15	91-262 409-15	8- 1	91-262 543-05	3- 13	96-108 406-16	9- 1
91-262 315-96	3- 15	91-262 410-92	3- 11	91-262 544-91	3- 8	99-069 722-01	3- 4,3- 5
91-262 320-91	3- 6	91-262 415-91	4- 6	91-262 547-05	3- 4,3- 5	99-133 220-01	3- 4,3- 5
91-262 325-91	4- 1,4- 2	91-262 416-91	4- 6	91-262 548-05	3- 4,3- 5	99-133 259-25	4- 1
91-262 326-15	3- 1	91-262 417-91	3- 16	91-262 549-92	3- 8	99-136 854-55	9- 3,9- 4
91-262 329-75/895	3- 1	91-262 418-91	3- 16	91-262 551-91	3- 4	99-137 151-45	3- 10
91-262 331-91	3- 16,3- 17	91-262 421-91	3- 6	91-262 552-12	3- 11	99-137 186-05	3- 16,3- 17
91-262 336-91	3- 5	91-262 422-05	3- 4,3- 6	91-262 554-92	3- 9	99-137 187-15	3- 16,3- 17
91-262 339-05	3- 4,3- 5	91-262 424-92	3- 9	91-262 559-15	4- 2	99-137 188-15	3- 16,3- 17
91-262 344-91	3- 9	91-262 425-12	3- 9	91-262 560-11	4- 3	99-137 189-05	3- 16,3- 17
91-262 345-12	3- 9	91-262 426-15	3- 4,3- 5	91-262 561-15	3- 1	99-137 190-05	3- 16,3- 17
91-262 346-12	3- 9	91-262 428-91	4- 1	91-262 568-05	7- 1	99-137 191-05	3- 16,3- 17
91-262 347-05	3- 9	91-262 429-05	4- 3	91-262 569-91	4- 2	99-137 192-05	3- 16,3- 17
91-262 348-91	3- 13	91-262 433-05	4- 1	91-262 570-95	4- 2	99-137 193-05	3- 16,3- 17
91-262 349-91	3- 13	91-262 434-15	4- 1	91-262 571-15	4- 2	99-137 194-05	3- 16,3- 17
91-262 350-15	3- 13	91-262 437-05	3- 16,3- 17	91-262 573-05	4- 5	99-137 196-05	9- 3
91-262 351-15	3- 13	91-262 438-01	3- 16	91-262 577-75/698	3- 11	99-137 226-91	9- 3
91-262 353-12	3- 13	91-262 440-71/895	5- 1	91-262 578-71/698	3- 11	99-137 247-45	3- 1,3- 21
91-262 354-05	3- 3	91-262 441-75/895	5- 1	91-262 628-91	3- 2	S-414 988-380-435	3- 2
91-262 355-92	3- 11	91-262 442-75/895	5- 1	91-262 639-05	3- 2	S-504 112-000-001	3- 3
91-262 357-75/698	8- 1	91-262 443-91	4- 3	91-265 065-05	4- 7	S-504 051-000-001	3- 15
91-262 360-05	3- 16,3- 17, 4- 6,4- 7	91-262 446-05	6- 1	91-265 189-05	3- 15	S-505 317-452-001	3- 15
91-262 364-91	4- 1	91-262 447-05	6- 1	91-265 198-15	3- 7		
91-262 367-91	3- 3	91-262 457-12	3- 2	91-266 397-01	3- 10		
91-262 368-91	3- 3	91-262 460-15	5- 1	91-267 082-05	3- 9		
91-262 369-91	7- 1	91-262 461-15	5- 1	91-268 076-15	3- 17,4- 7		
91-262 370-15	7- 1	91-262 513-05	5- 1	91-290 733-91	3- 14		
91-262 372-92	7- 1	91-262 514-05	4- 6	91-700 785-15	3- 19		
91-262 376-91	3- 17	91-262 536-15	3- 1	95-600 649-05	5- 1		
91-262 377-91	3- 16,3- 17	91-262 538-05	3- 13	95-665 735-91	15- 1		

1051

1181

Unterklassen-Ausstattung

Subclass parts

Composition des sous-classes

Composición de las subclases

Unterklasse Subclass Sous-classe Subclase	-8/11	-8/11-900/24	-8/12	-8/12-900/24
Arbeitsgang Operation Opération Operación	Universalteilesatz, zum Nähen feiner Materialien. Universal part set for sewing light-weight materials. Jeu de pièces universel, pour matières fines. Juego de piezas universal, para materiales finos.	Universalteilesatz, zum Nähen feiner Materialien. Universal part set for sewing light-weight materials. Jeu de pièces universel, pour matières fines. Juego de piezas universal, para materiales finos.	Zum Nähen besonders feiner Stoffe mittels Brücken-Teilesatz. For stitching delicate fabrics with Bridge-type part set. Couture de tissus particulièrement fins; jeu de pièces en pont. Para géneros muy finos mediante juego de piezas en puente.	Zum Nähen besonders feiner Stoffe mittels Brücken-Teilesatz. For stitching delicate fabrics with Bridge-type part set. Couture de tissus particulièrement fins; jeu de pièces en pont. Para géneros muy finos mediante juego de piezas en puente.
Teilesatz vollst. Part set assy. Jeu de pièces complète Juego de piezas compl.				
Nadelstange Needle bar Barre à aiguille Bara de aguja	91-262 367-91 6/3 91-262 368-91 6/4	91-262 367-91 6/3 91-262 368-91 6/4	91-262 367-91 6/3 91-262 368-91 6/4	91-262 367-91 6/3 91-262 368-91 6/4
Nähfuß * Presser foot Pied presseur Pie prensatelas	91-154 172-21	91-154 172-21	91-054 841-23/001	91-054 841-23/001
Stichplatte * Needle plate Plaque à aiguille Placa de aguja	91-150 671-25	91-150 671-25	91-150 673-25	91-150 673-25
Stoffschieber * Feed dog Griffe Transportador inferior	91-059 816-05	91-059 816-05	91-059 812-04/002	91-059 812-04/002
Schieber * Slide Glissière Corredera	S-505 317-452-001	S-505 317-452-001	S-505 317-452-001	S-505 317-452-001

Unterklassen-Übersicht

Table of subclasses

Table de sous-classes

Tabla de subclases

PFAFF 1051

PFAFF 1181

17.01

Unterklasse Subclass Sous-classe Subclase	-8/ 13	-8/ 13-900/ 24
Arbeitsgang Operation Opération Operación	Universalteilersatz, zum Nähen für mittlere bis mittelschwere Materialien. Universal part set for sewing for medium-weight materials to medium-heavy materials. Jeu de pièces universel, pour matières moyennes à matières mi-lourdes. Juego de piezas universal, para materiales semifinos hasta de materiales semipesados.	Universalteilersatz, zum Nähen für mittlere bis mittelschwere Materialien. Universal part set for sewing for medium-weight materials to medium-heavy materials. Jeu de pièces universel, pour matières moyennes à matières mi-lourdes. Juego de piezas universal, para materiales semifinos hasta de materiales semipesados.
Teilesatz vollst. Part set assy. Jeu de pièces complète Juego de piezas compl.		
Nadelstange Needle bar Barre à aiguille Bara de aguja	91-262 367-91 6/3 91-262 368-91 6/4	91-262 367-91 6/3 91-262 368-91 6/4
Nähfuß * Presser foot Pied presseur Pie prensatelas		
Stichplatte * Needle plate Plaque à aiguille Placa de aguja		
Stoffschieber * Feed dog Griffe Transportador inferior		
Schieber * Slide Glissière Corredera	S-505 317-452-001	S-505 317-452-001

17.02

Nähwerkzeuge
 Gauge parts
 Organes de couture PFAFF 1051
 Organos de costura PFAFF 1181

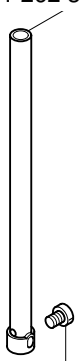
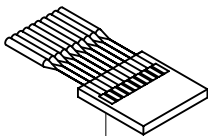
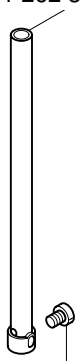
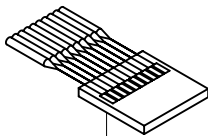
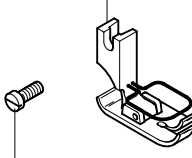
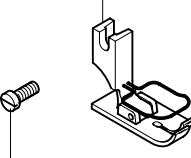
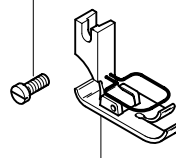
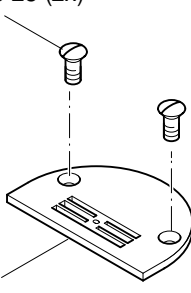
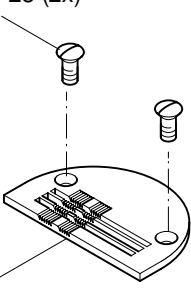
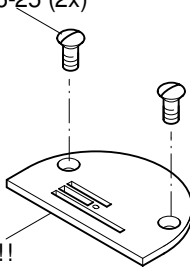
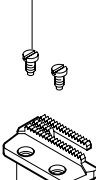
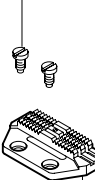
<p>91-262 367-91 6/3</p>  <p>S-504 112-000-001</p>  <p>System DBx1 6 Système DBx1 6 Sistema DBx1 6</p> <p>-8/11 -8/11-900/24 -8/12 -8/12-900/24 -8/13 -8/13-900/24</p>	<p>91-262 368-91 6/4</p>  <p>S-504 112-000-001</p>  <p>System 134 6 Système 134 6 Sistema 134 6</p> <p>-8/11 -8/11-900/24 -8/12 -8/12-900/24 -8/13 -8/13-900/24</p>	<p>91-054 841-23/001</p>  <p>11-108 174-25</p> <p>-8/12 -8/12-900/24</p>	<p>91-154 172-21</p>  <p>11-108 174-25</p> <p>-8/11 -8/11-900/24</p>	
		<p>11-108 174-25</p>  <p>Nr. fehlt!!</p> <p>-8/13 -8/13-900/24</p>		
<p>91-100 296-25 (2x)</p>  <p>91-150 671-25</p> <p>-8/11 -8/11-900/24</p>	<p>91-100 296-25 (2x)</p>  <p>91-150 673-25</p> <p>-8/12 -8/12-900/24</p>	<p>91-100 296-25 (2x)</p>  <p>Nr. fehlt!!</p> <p>-8/13 -8/13-900/24</p>	<p>S-504 051-000-001 (2x)</p>  <p>91-059 812-04/002</p> <p>-8/12 -8/12-900/24</p>	<p>S-504 051-000-001 (2x)</p>  <p>91-059 816-05</p> <p>-8/11 -8/11-900/24</p>

S-504 051-000-001 (2x)

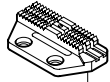

Nr. fehlt!!

-8/13

-8/13-900/24

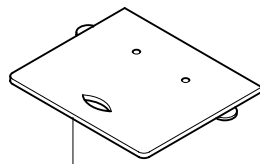

S-505 317-452-001

-8/11

-8/11-900/24

-8/12

-8/12-900/24

-8/13

-8/13-900/24

1053

1183

Unterklassen-Ausstattung

Subclass parts

Composition des sous-classes

Composición de las subclases

Unterklasse Subclass Sous-classe Subclase	-8/31	-8/31-900/24	-8/33	-8/33-900/24
Arbeitsgang Operation Opération Operación	Universalteilesatz, zum Nähen feiner Materialien. Universal part set for sewing light-weight materials. Jeu de pièces universel, pour matières fines. Juego de piezas universal, para materiales finos.	Universalteilesatz, zum Nähen feiner Materialien. Universal part set for sewing light-weight materials. Jeu de pièces universel, pour matières fines. Juego de piezas universal, para materiales finos.	Universalteilesatz, zum Nähen für mittlere bis mittelschwere Materialien. Universal part set for sewing for medium-weight materials to medium-heavy materials. Jeu de pièces universel, pour matières moyennes à matières mi-lourdes. Juego de piezas universal, para materiales semifinos hasta de materiales semipesados.	Universalteilesatz, zum Nähen für mittlere bis mittelschwere Materialien. Universal part set for sewing for medium-weight materials to medium-heavy materials. Jeu de pièces universel, pour matières moyennes à matières mi-lourdes. Juego de piezas universal, para materiales semifinos hasta de materiales semipesados.
Teilesatz vollst. Part set assy. Jeu de pièces complète Juego de piezas compl.	91-202 099-91	91-202 099-91	91-202 100-91	91-202 100-91
Nadelstange Needle bar Barre à aiguille Barra de aguja	91-262 367-91 ^[6/3] 91-262 368-91 ^[6/4]	91-262 367-91 ^[6/3] 91-262 368-91 ^[6/4]	91-262 367-91 ^[6/3] 91-262 368-91 ^[6/4]	91-262 367-91 ^[6/3] 91-262 368-91 ^[6/4]
Nähfuß * Presser foot Pied presseur Pie prensatelas	S-505 643-458-435	S-505 643-458-435	S-543 419-458-435	S-543 419-458-435
Stichplatte * Needle plate Plaque à aiguille Placa de aguja	S-414 464-452-435	S-414 464-452-435	S-012 482-452-435	S-012 482-452-435
Stoffschieber * Feed dog Griffe Transportador inferior	S-376 445-000-435	S-376 445-000-435	S-012 481-000-435	S-012 481-000-435
Schieber * Slide Glissière Corredera	S-505 317-452-001	S-505 317-452-001	S-505 317-452-001	S-505 317-452-001

Unterklassen-Übersicht

Table of subclasses

Table de sous-classes

Tabla de subclases

PFAFF 1053

PFAFF 1183

17.03

Unterklasse Subclass Sous-classe Subclase	-8/ 34	-8/ 34-900/ 24	-8/ 44	-8/ 44-900/ 24
Arbeitsgang Operation Opération Operación	Zum Nähen besonders feiner Stoffe mittels Brücken-Teilesatz. For stitching delicate fabrics with Bridge-type part set. Couture de tissus particulière-ment fins; jeu de pièces en pont. Para géneros muy finos mediante juego de piezas en puente.	Zum Nähen besonders feiner Stoffe mittels Brücken-Teilesatz. For stitching delicate fabrics with Bridge-type part set. Couture de tissus particulière-ment fins; jeu de pièces en pont. Para géneros muy finos mediante juego de piezas en puente.	Für Stepparbeiten an Schuh-schäften und sonstigen Lederwaren mittels angetriebe-nem Rollfuß. For stitching shoe uppers and other leather articles with driven roller presser. Travaux de piquage sur tiges ou autres en cuir, par pied à roulette entraînée. Para trabajos de respunteado en cortes de calzado y en artículos de cuero mediante pie rodante accionado.	Für Stepparbeiten an Schuh-schäften und sonstigen Lederwaren mittels angetriebe-nem Rollfuß. For stitching shoe uppers and other leather articles with driven roller presser. Travaux de piquage sur tiges ou autres en cuir, par pied à roulette entraînée. Para trabajos de respunteado en cortes de calzado y en artículos de cuero mediante pie rodante accionado.
Teilesatz vollst. Part set assy. Jeu de pièces complète Juego de piezas compl.			91-262 521-90	91-262 521-90
Nadelstange Needle bar Barre à aiguille Barra de aguja	91-262 367-91 6/3 91-262 368-91 6/4	91-262 367-91 6/3 91-262 368-91 6/4	91-262 565-92*	91-262 565-92*
Nähfuß * Presser foot Pied presseur Pie prensatelas				
Rollfuß 4 * Roller presser Pied à roulette Pie rodante			91-051 155-93/001	91-051 155-93/001
Stichplatte * Needle plate Plaque à aiguille Placa de aguja			S-414 213-452-001	S-414 213-452-001
Stoffschieber * Feed dog Griffe Transportador inferior			S-149 436-000-001	S-149 436-000-001
Schieber * Slide Glissière Corredera	S-505 317-452-001	S-505 317-452-001	S-505 317-452-001	S-505 317-452-001
Stoffdrückerstange * Presser bar Barre presse-tissu Barra del prensatelas			91-171 075-91	91-171 075-91
Buchse zur Stoffdrückerstange * Bushing Douille pour barre presse-t Casquillo para barra prensatelas			91-171 557-05	91-171 557-05
Fadenführungshaken * Thread guide hook Crochet guide-fil Gancho del prendehilos			91-262 520-25	91-262 520-25

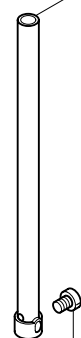
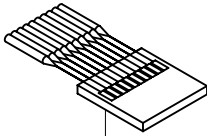
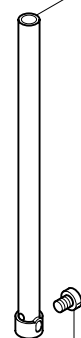
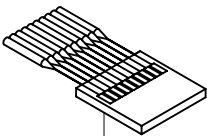
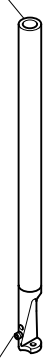
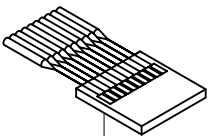
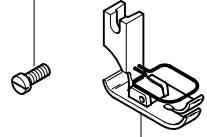
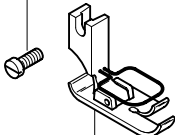
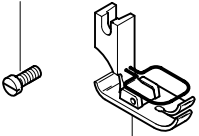
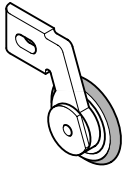
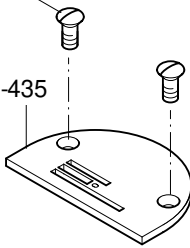
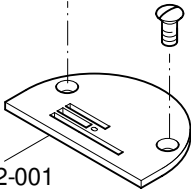
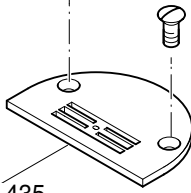
<p>91-262 367-91 6/3</p>  <p>S-504 112-000-001</p>  <p>System DBx1 6 Système DBx1 6 Sistema DBx1 6</p> <p>-8/31 -8/31-900/24 -8/33 -8/33-900/24 -8/34 -8/34-900/24</p>	<p>91-262 368-91 6/4</p>  <p>S-504 112-000-001</p>  <p>System 134 6 Système 134 6 Sistema 134 6</p> <p>-8/31 -8/31-900/24 -8/33 -8/33-900/24 -8/34 -8/34-900/24</p>	<p>91-262 565-92</p>  <p>11-330 085-15</p>  <p>System 134 6 Système 134 6 Sistema 134 6</p> <p>-8/44 -8/44-900/24</p>	<p>11-108 174-25</p>  <p>S-505 643-458-435</p> <p>-8/31 -8/31-900/24</p> <hr/> <p>11-108 174-25</p>  <p>S-543 419-458-435</p> <p>-8/33 -8/33-900/24</p>
<p>11-108 174-25</p>  <p>Nr. fehlt</p> <p>-8/34 -8/34-900/24</p>	<p>91-051 155-93/001</p>  <p>-8/44 -8/44-900/24</p>	<p>91-100 296-25 (2x)</p>  <p>S-012 482-452-435</p> <p>-8/33 -8/33-900/24</p>	
<p>91-100 296-25 (2x)</p>  <p>S-414 213-452-001</p> <p>-8/44 -8/44-900/24</p>		<p>91-100 296-25 (2x)</p>  <p>S-414 464-452-435</p> <p>-8/31 -8/31-900/24</p>	

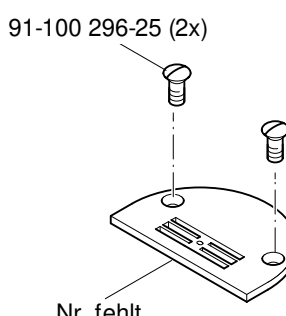
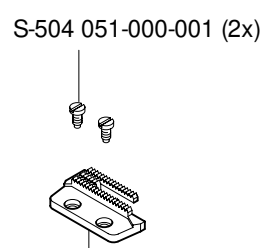
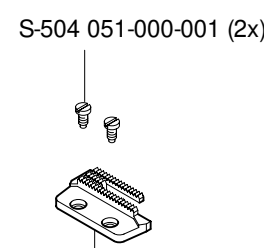
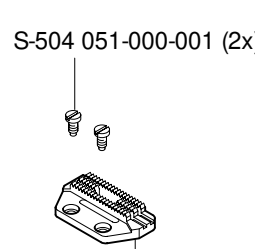
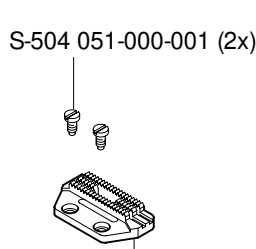
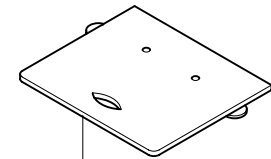
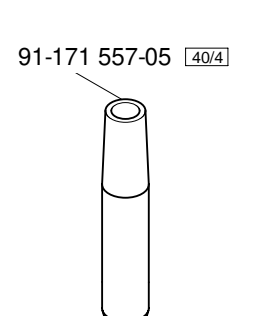
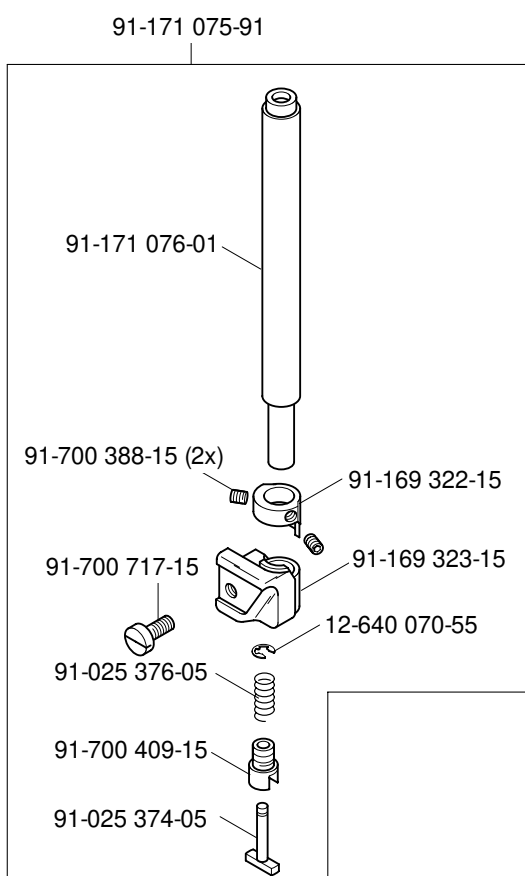
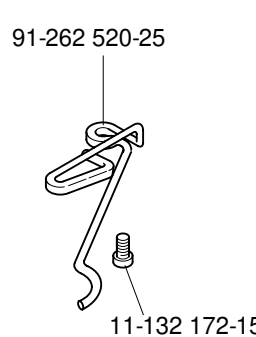
 <p>91-100 296-25 (2x)</p> <p>Nr. fehlt</p> <p style="text-align: right;">-8/ 34 -8/ 34-900/ 24</p>	 <p>S-504 051-000-001 (2x)</p> <p>S-012 481 000-435</p> <p style="text-align: right;">-8/ 33 -8/ 33-900/ 24</p>	 <p>S-504 051-000-001 (2x)</p> <p>S-149 436-000-001</p> <p style="text-align: right;">-8/ 44 -8/ 44-900/ 24</p>	
 <p>S-504 051-000-001 (2x)</p> <p>S-376 445-000-435</p> <p style="text-align: right;">-8/ 31 -8/ 31-900/ 24</p>	 <p>S-504 051-000-001 (2x)</p> <p>Nr. fehlt</p> <p style="text-align: right;">-8/ 34 -8/ 34-900/ 24</p>	 <p>S-505 317-452-001</p> <p style="text-align: right;">-8/ 31 -8/ 31-900/ 24 -8/ 33 -8/ 33-900/ 24 -8/ 34 -8/ 34-900/ 24 -8/ 44 -8/ 44-900/ 24</p>	 <p>91-171 557-05 40/4</p> <p style="text-align: right;">-8/ 44 -8/ 44-900/ 24</p>
 <p>91-171 075-91</p> <p>91-171 076-01</p> <p>91-700 388-15 (2x)</p> <p>91-169 322-15</p> <p>91-700 717-15</p> <p>91-169 323-15</p> <p>12-640 070-55</p> <p>91-025 376-05</p> <p>91-700 409-15</p> <p>91-025 374-05</p> <p style="text-align: right;">-8/ 44 -8/ 44-900/ 24</p>		 <p>91-262 520-25</p> <p>11-132 172-15</p> <p style="text-align: right;">-8/ 44 -8/ 44-900/ 24</p>	

PFAFF