

- MO-2000N / S057,S058** Swing type Intermittent Shirring Attachment(Pedal type)  
スイング方式ひだ取り装置 (ペダル式)
- MO-2000N / S097,S098** Swing type Intermittent Shirring Attachment(Manual type)  
スイング方式ひだ取り装置 (手動式)
- MO-2000N / S112** Swing type Intermittent Shirring Attachment(Pedal / Manual type)  
スイング方式上ひだ取り装置 (手動・ペダル式)
- MO-2000N / S114,S115** Swing type Lower Intermittent Shirring Attachment  
スイング方式下布ひだ取り装置
- MO-2000N / S118,S119** Swing type Intermittent Shirring Attachment(Pedal type)  
スイング方式上ひだ取り装置 (ペダル式)

## PARTS LIST

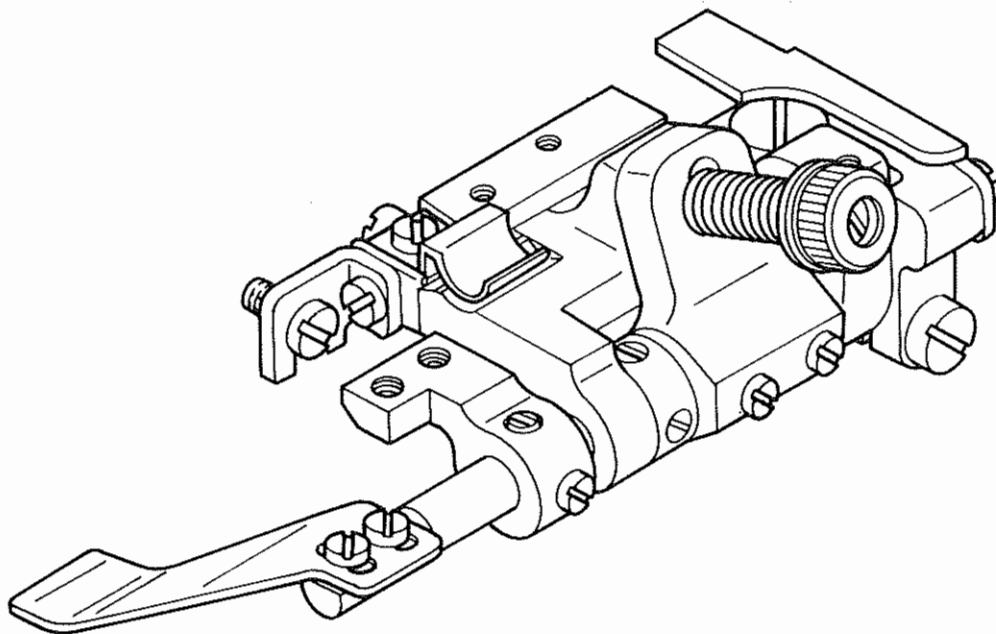

# HOW TO MAKE USE OF THIS PARTS LIST

## パーツリストの見方

1. The part numbers of parts shown in the figure indicate the corresponding numbers (Ref. No.) shown by the Index.  
 図に示された部品の品番は、図にふられているNo (Ref.No)に対応するインデックスによって、その品番がわかります

2. Explanation of codes  
 記号の説明

1) Codes on the "Note" column  
 "注記"欄の記号

- ① ☆..... means this part is changed from the previous parts list.  
 前回のパーツリストに対して今回変更された部品を意味します
- ② #01..... refer to the "Note" explanation at bottom of page.  
 001 ページ下の"注記"の説明を参照して下さい。

2) Codes on the "E.C. (Engineering change)" column  
 "変更年月"欄の記号

- ① A.10/83.... Added from October, 1983  
 1983年10月より追加された。
- ② D.10/83.... Obsolete from October, 1983  
 1983年10月より削除された。

③ When previous parts (Obsoleted part) and new parts (Added parts) are not interchangeable with each other:  
 部品の互換性がない変更の場合

In this case, even obsoleted part (D.) can be ordered with the obsoleted part number, so select the parts with changed dates and place your orders.  
 この場合は削除(D)された品番でもご注文できますから、変更年月により、いずれかの部品を選択してご注文下さい。

Example (例)

Ref. No.	Note 注記	Part No. 品番	Description	E.C. 変更年月	品名	Amt. Req. 数量
1	☆	B1401-100-000	Needle bar	D.10/83	ハリホー	-
1-1	☆	B1401-100-000-A	Needle bar	A.10/83	ハリホー	1
2	☆	B1105-200-000	Frame cover	D.10/83	<b>B1105-300-000</b>	-
	☆	<b>B1105-300-000</b>	Frame cover	A.10/83	フレームカバー	1

④ In case when previous parts and new part are interchangeable with each other:  
 部品の互換性がある場合の変更

In this case the new part number is replaced on the "品名 (Japanese)" column of the previous parts, so please order by the new part number.  
 この場合は、旧部品の和文品名欄にそれにかわる新しい品番が記入してありますので、新しい品番でご注文下さい。

⑤ C.10/83

1	☆	<b>B1105-500-000</b>	Frame cover	C.10/83	<del>B1105-600-000</del>	1
		↑ Correct No. 正しい品番			↑ Wrong No. 誤り品番	

Please order by the correct part number.  
 正しい品番でご注文下さい。

⑥ M.10/83..... The amount required is changed from October, 1983  
 The new amount required is shown in the "Amt. Req." column.  
 1983年10月より数量が変更になった。この場合数量欄には新しい数量が表示してあります。

3) Codes on the "Amt. Req." column  
 "数量"欄の記号

- ① 2..... Indicates amount required is 2.  
 数量、2個を表わします。
- ② 2.0..... Indicates length in meters. (unit is meter)  
 長さ、2メートルを表わします。(単位はメートルです)
- ③ -..... Indicates parts obsoleted from the parts list.  
 このパーツリストから削除された部品です。
- ④ (1)..... Indicates sub parts which construct the assembly part.  
 Assembly part is shown as "asm." and クミ in Japanese, in the "Description" column.  
 組部品を構成している子部品を表わします。組部品は品名欄に英文で "asm." 和文でクミと表示してあります。

### When Ordering The Spare Parts:

In order to ensure that we deliver the correct parts to you, please clearly state when ordering the corresponding PART NUMBER (ex. B1109-012-A00) and also the PARTS LIST NUMBER (ex. 0010-01, given at the bottom right of the cover) or the MACHINE SERIAL NUMBER, because there are some parts which have been changed.

### 補用部品注文の際のご注意

このパーツリストに記載されている補用部品をご注文の際は、部品の番号(例えば、B1109-012-A00)でご注文下さい。合わせて、ご覧のパーツリストの管理番号(表紙右下、例えば、No0010-01)又は、機械番号をご連絡頂ければ幸いです。又、改良のため部品の一部が変更になる場合がありますのでご了承下さい。

# CONTENTS

## 目 次

1. TABLE OF SWING TYPE INTERMITTENT SHIRring ATTACHMENT .....	1
スイング方式ひだ取り装置一覧表	
2. SIMULTANEOUS EXCHANGING GAUGE PARTS (FOR MO-2000N SERIES) .....	2
同時交換ゲージ部品 (MO-2000Nシリーズ用)	
(1) S057, S097	
(2) S058, S098	
3. S057, S058: SWING TYPE INTERMITTENT SHIRring ATTACHMENT (PEDAL TYPE) .....	3
S057, S058: スイング方式ひだ取り装置 (ペダル式)	
4. S097, S098: SWING TYPE INTERMITTENT SHIRring ATTACHMENT (MANUAL TYPE) .....	5
S097, S098: スイング方式ひだ取り装置 (手動式)	
5. KNEE OPERATING COMPONENTS .....	7
膝作動装置関係	
6. S112: SWING TYPE UPPER INTERMITTENT SHIRring ATTACHMENT .....	9
(MANUAL/PEDAL TYPE)	
S112: スイング方式上ひだ取り装置 (手動・ペダル式)	
7. S114, S115: SWING TYPE LOWER INTERMITTENT SHIRring ATTACHMENT .....	11
S114, S115: スイング方式布ひだ取り装置	
8. SIMULTANEOUS EXCHANGING GAUGE PARTS (FOR MOR-2500N SERIES) .....	12
MOR-2500N シリーズ同時交換ゲージ部品	
(1) S112	
(2) S114, S098	
(3) S115, S097	
9. S118, S119: SWING TYPE UPPER INTERMITTENT SHIRring ATTACHMENT .....	13
(PEDAL TYPE)	
S118, S119: スイング方式上ひだ取り装置 (ペダル式)	
NUMERICAL INDEX OF PARTS .....	15
索引	

1. TABLE OF SWING TYPE INTERMITTENT SHIRRING ATTACHMENT  
 スイング方式ひだ取り装置一覧表

<b>PEDAL TYPE</b> (For fully-sunken, semi-sunken type table) ペダル式 (全沈、半沈式テーブル用)		<b>MANUAL TYPE</b> (For only semi-sunken type table) 手動式 (半沈式テーブル用のみ)	
<b>S057</b> Intermittent shirring attachment for safety stitcher インターロックミシン用ひだ取り装置		<b>S097</b> Intermittent shirring attachment for safety stitcher インターロックミシン用ひだ取り装置	
<b>S058</b> Intermittent shirring attachment for overedger オーバーロックミシン用ひだ取り装置		<b>S098</b> Intermittent shirring attachment for overedger. オーバーロックミシン用ひだ取り装置	
Attachment 装置品番	Constitution parts 構成品番	Attachment	Constitution parts 構成品番
<b>S057</b> MAS-057000A0-A	1. MAS-057050A0-A 2. SS-7110710-SP 3. SS-6151040-SP 4. 118-19307 5. MAS-05714000 6. SS-8090410-SP 7. SS-6110610-TP 8. MAS-05715000 9. MAS-107010A0 10. MAS-10704000 11. SM-9083013-SC 12. MAS-10701000 13. WP-0850002-SC 14. NM-6080600-SM 15. SM-9084533-SC 16. MAS-107010C0 17. MAS-057010A0	<b>S097</b> MAS-097000A0	9. MAS-107010A0 10. MAS-10704000 11. SM-9083013-SC 12. MAS-10701000 13. WP-0850002-SC 14. NM-6080600-SM 15. SM-9084533-SC 16. MAS-107010C0 19. MAS-097010A0
<b>S058</b> MAS-058000A0-A	1 ~ 16 18. MAS-058010A0	<b>S098</b> MAS-098000A0	9 ~ 16 20. MAS-098010A0
Series	Attachment	Series	
MO-2400N MO-2500N	<b>S057</b> MO-2416N, MO-2516N BD4, DD4, FF6, RH6 DD6, -320	<b>S058</b> MO-2404N-OD6-320 MO-2414N-BD6-320 MO-2504N-OD6-320 MO-2514N-BD6-320	<b>S097</b> MO-2416N, MO-2516N BD4, DD4, FF6, RH6 DD6, -320/S097 MOR-2516N-FF6
		<b>S098</b> MO-2404N-OD6-320 MO-2414N-BD6-320 MO-2504N-OD6-320 MO-2514N-BD6-320 MOR-2514N-BD6	

2. SIMULTANEOUS EXCHANGING GAUGE PARTS (FOR MO-2000N SERIES)  
同時交換ゲージ部品 (MO-2000Nシリーズ用)

(1) S057, S097

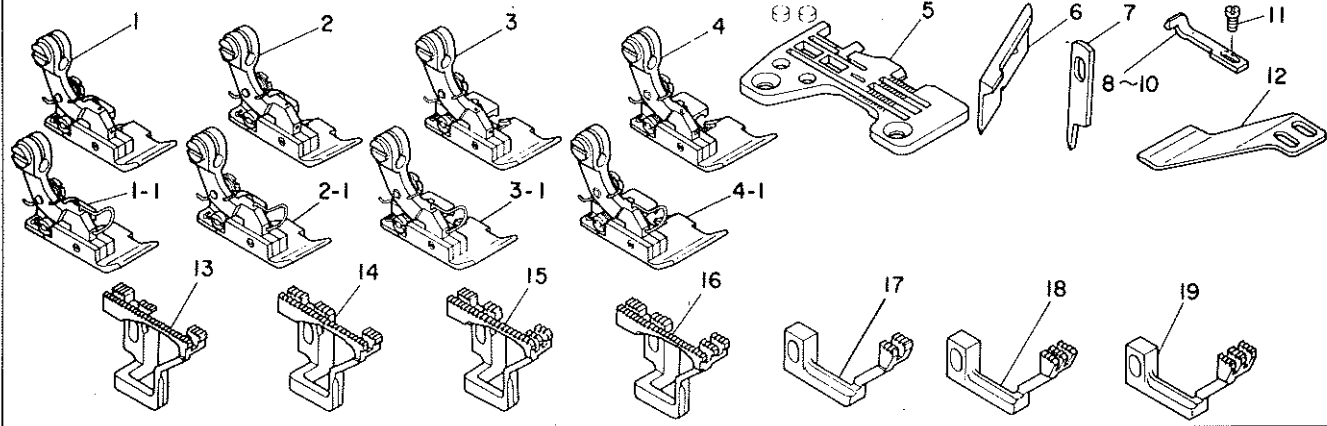

Ref. No.	Note	Part No. 品番	Description	E. C. 変更年月	品名	Amt. Req. 数量
1	◇01	118-79558	PRESSER FOOT ASM.		オワイ クミ	1
1-1	◇15	118-79566	PRESSER FOOT ASM.	A.02/84	シムツオワイクミ (シビカ-トツキ)	1
2	◇02	118-79657	PRESSER FOOT ASM.		オワイ クミ	1
2-1	◇15	118-79665	PRESSER FOOT ASM.	A.02/84	シムツオワイクミ (シビカ-トツキ)	1
3	◇04	118-80457	PRESSER FOOT ASM.		オワイ クミ	1
3-1	◇15	118-80465	PRESSER FOOT ASM.	A.02/84	シムツオワイクミ (シビカ-トツキ)	1
4	◇07	118-80853	PRESSER FOOT ASM.		オワイ クミ	1
4-1	◇15	118-80861	PRESSER FOOT ASM.	A.02/84	シムツオワイクミ (シビカ-トツキ)	1
5	◇04	R4612-HOF-B00	THROAT PLATE		ハリイダ	1
6	◇05	118-45807	UPPER KNIFE	C.11/84	ウツメス	1
7	◇05	118-45609	KNIFE		ヒラメス	1
8	◇06	B4120-816-DOB-A	NEEDLE GUARD		ハリウケ E	1
9	◇04	B4120-816-FOC-A	NEEDLE GUARD		ハリウケ E	1
10	◇07	B4120-816-ROA	NEEDLE GUARD		ハリウケ	1
11	◇08	SS-7060610-SP	SCREW 3/32-56 L= 5.5		メネヒラメス 3/32-56 L=5.5	1
12	◇07	MAS-0510800A	INTERMITTENT SHIRRING PRESSER PLATE		ヒタトリオワイ	1
13	◇09	118-83709	MAIN FEED DOG		シユオクリハ	1
14	◇10	118-83808	MAIN FEED DOG		シユオクリハ	1
15	◇11	118-83907	MAIN FEED DOG		シユオクリハ	1
16	◇03	118-84103	MAIN FEED DOG		シユオクリハ	1
17	◇05	118-85704	DIFFERENTIAL FEED DOG		フクオクリハ	1
18	◇11	118-85803	DIFFERENTIAL FEED DOG		フクオクリハ	1
19	◇03	118-85902	DIFFERENTIAL FEED DOG		フクオクリハ	1

• The same throat plate can be used independent of other replacement (except FF6)  
針板については交換する必要はありません(FF6を除いて)

• Each notes apply also to model MO-2416N, MO-2516N  
各注記についてはMO-2416N, MO-2516N それぞれ共通

Note (注記) ◇01 ..... For BD4-320	BD4-320用	◇07 ..... For RH6-320	RH6-320用
◇02 ..... For DD4-320, DD6-320	DD4-320, DD6-320用	◇08 ..... For S057, S097	S057, S097用
◇03 ..... For FF6-320, RH6-320	FF6-320, RH6-320用	◇09 ..... For BD4-320	BD4-320用
◇04 ..... For FF6-320	FF6-320用	◇10 ..... For DD4-320	DD4-320用
◇05 ..... For BD4-320, DD4-320	BD4-320, DD4-320用	◇11 ..... For DD6-320	DD6-320用
◇06 ..... For BD4-320, DD4-320	BD4-300, DD4-320用	◇15 ..... For export	輸出用

(2) S058, S098

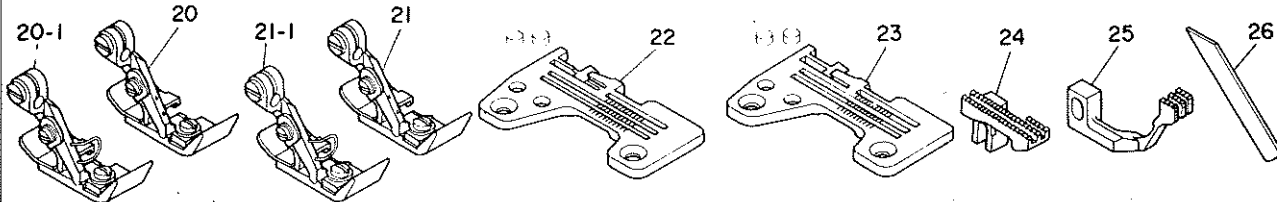

Ref. No.	Note	Part No. 品番	Description	E. C. 変更年月	品名	Amt. Req. 数量
20	◇13	118-79350	PRESSER FOOT ASM.		オワイ クミ	1
20-1	◇15	118-79368	PRESSER FOOT ASM.	A.02/84	オワイクミ (シビカ-トツキ)	1
21	◇12	118-78857	PRESSER FOOT ASM.		オワイ クミ	1
21-1	◇15	118-78865	PRESSER FOOT ASM.	A.02/84	オワイクミ (シビカ-トツキ)	1
22	◇13	R4305-HOD-E0A	THROAT PLATE		ハリイダ	1
23	◇12	R4300-HOD-D0A	THROAT PLATE		ハリイダ	1
24	◇14	118-83402	MAIN FEED DOG		シユオクリハ	1
25	◇14	B1657-814-RCL	DIFFERENTIAL FEED DOG		フクオクリハ	1
26	◇12	118-97501	LOWER KNIFE		シタメス B	1

NOTE (注記) ◇12..... For OD6-320 (MO-2404N, 2414N, 2504N, 2514N) OD6-320用 (MO-2404N, 2414N, 2504N, 2514N)  
 ◇13..... For BD6-320 (MO-2404N, 2504N, 2514N) BD6-320用 (MO-2404N, 2414N, 2504N, 2514N)  
 ◇14..... For S058, S098 (MO-2404N, 2414N, 2504N, 2514N) S058, S098用 (MO-2404N, 2414N, 2504N, 2514N)  
 ◇15..... For export 輸出用

3. S057, S058: SWING TYPE INTERMITTENT SHIRING ATTACHMENT (PEDAL TYPE)  
 S057, S058: スイング方式ひだ取り装置 (ペダル式)

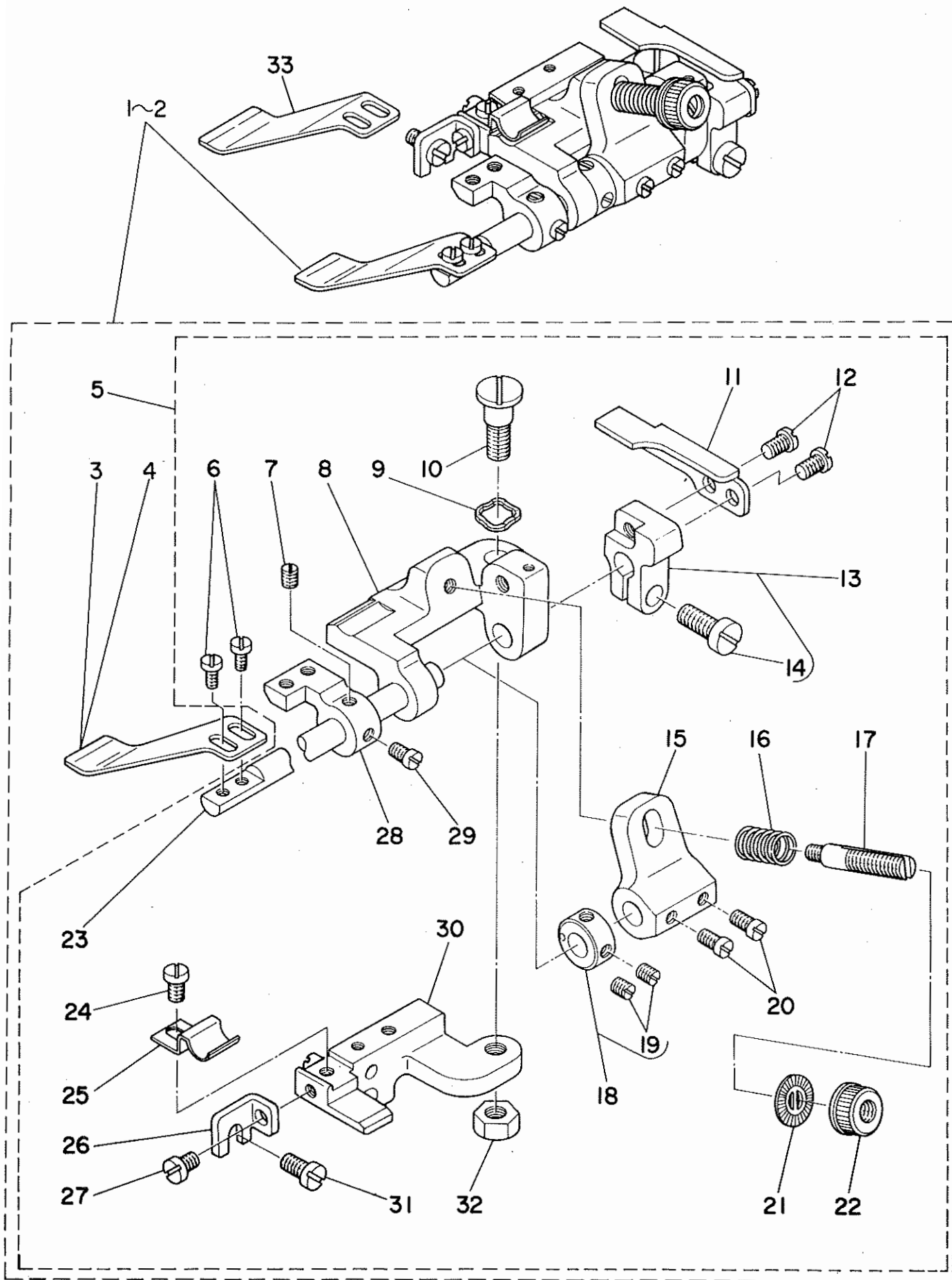

Ref. No.	Note 注記	Part No. 品番	Description	E. C. 変更年月	品名	Amt. Req. 数量
1	◇01	MAS-057010A0	PEDAL SHIRRING ATTACHMENT ASM.		ヒタ*トリツウチ クミ	1
2	◇02	MAS-058010A0	PEDAL SHIRRING ATTACHMENT ASM.		ヒタ*トリツウチ クミ	1
3	◇01	MAS-05108000	INTERMITTENT SHIRRING PRESSER PLATE		ヒタ*トリオウエ	(1)
4	◇02	MAS-05208000	INTERMITTENT SHIRRING PLATE		ヒタ*トリオウエ	(1)
5		MAS-057010B0	PEDAL SHIRRING ATTACHMENT ASM.		ヒタ*トリツウチ クミ	(1)
6		SS-6090650-SP	SCREW 9/64-40 L=6		ヒラネシ* 9/64-40 L=6	(2)
7		SS-8110520-TP	SCREW 11/64-40 L= 4.5		トメネシ* 11/64-40 L=4.5	(1)
8		MAS-05702000	SWING BASE		ヒタ*トリオウエ シシ*タイ	(1)
9		WZ-0850302-K0	WAVED WASHER 8.5X13X0.3		ナミカ*タウ*カ*ネ 8.5X12.5X0.3	(1)
10		SD-0790801-SP	HINGE SCREW D=7.94 H=8		タ*ンネシ* D=7.94 H=8	(1)
11		MAS-05703000	LIFTING ARM		ヒキアケ*ウチ*	(1)
12		SS-7110710-SP	SCREW 11/64-40 L=7		マルヒラネシ* 11/64-40 L=7	(2)
13		MAS-052070A0	LIFTING ARM MOUNTING BLOCK ASM.,A		ヒキアケ*ウチ* トリツウチ*クミ	(1)
14		SS-6151440-SP	SCREW 15/64-28 L=14		ヒラネシ* 15/64-28 L=14	(1)
15		MAS-05204000	APM		ヒタ*トリオウエ ハネウチ*	(1)
16		MAS-05205000	SPRING		ヒタ*トリオウエハネ	(1)
17		B3105-804-000	TENSION POST		イトチヨ-シホ**	(1)
18		CS-079081A-SP	THRUST COLLAR ASM. D=7.94 W=8		スラストウケ D=7.94 W=8	(1)
19		SS-8110520-TP	SCREW 11/64-40 L= 4.5		トメネシ* 11/64-40 L=4.5	(2)
20		SS-6110710-TP	SCREW 11/64-40 L= 6.5		ヒラネシ* 11/64-40 L=6.5	(2)
21		B3120-125-000	TENSION DISC STOPPER		イトチヨ-シハラ カイテント*メ	(1)
22		B3116-125-000	TENSION NUT		イトチヨ-シ ナツト	(1)
23		MAS-05206000	SHAFT		ヒタ*トリシ*ク	(1)
24		SS-7110710-SP	SCREW 11/64-40 L=7		マルヒラネシ* 11/64-40 L=7	(1)
25		MAS-05209000	SPRING		ヒタ*トリオウエ シシ*タイハネ	(1)
26		MAS-05704000	SWING BASE ROTATING STOPPER		ヒタ*トリオウエ トリツウチ*イ マウリト*メ	(1)
27		SS-7110510-SP	SCREW 11/64-40 L=5		マルヒラネシ* 11/64-40 L= 5	(1)
28		MAS-05212000	PIPING MOUNTING BLOCK		ハ*イ*ヒ*ンク* トリツウチ*イ	(1)
29		SS-6110650-TP	SCREW 11/64-40 L=5.5		ヒラネシ* 11/64-40 L=5.5	(1)
30		MAS-057010C0	PRESSER PLATE BASE ASM.		ヒタ*トリオウエ トリツウチ*イ クミ	(1)
31		SS-6120940-SP	SCREW 3/16-28 L=9		ヒラネシ* 3/16-28 L=9	(1)
32		NS-6160520-SP	NUT 1/4-24		ロツカクナツト 1/4-24	(1)
33	◇03	MAS-0510800A	INTERMITTENT SHIRRING PRESSER PLATE		ヒタ*トリオウエ	1

Note (注記) ◇01 ..... For S057  
◇02 ..... For S058  
◇03 ..... For RH6-320

S057用  
S058用  
RH6-320用

4. S097, S098: SWING TYPE INTERMITTENT SHIRING ATTACHMENT (MANUAL TYPE)  
 S097, S098: スイング方式ひだ取り装置 (手動式)

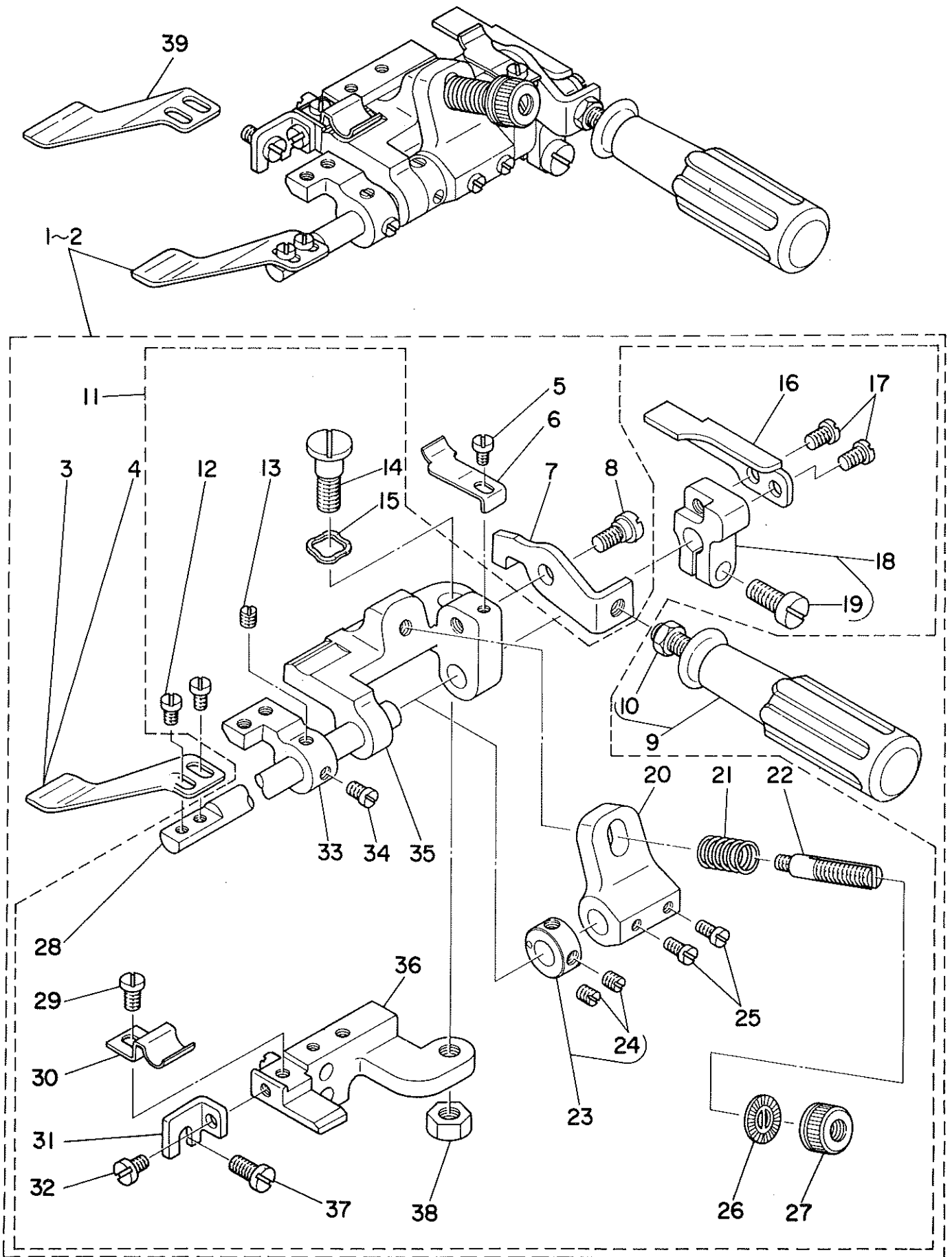



Ref. No.	Note 注記	Part No. 品番	Description	E. C. 変更年月	品名	Amt. Req. 数量
1	◇01	MAS-097010A0	MANUAL SHIRRING ATTACHMENT ASM		シユト* - ヒタ*トリソ-チ クミ	1
2	◇02	MAS-098010A0	MANUAL SHIRRING ATTACHMENT ASM		シユト* - ヒタ*トリソ-チ クミ	1
3	◇01	MAS-05108000	INTERMITTENT SHIRRING PRESSER PLATE		ヒタ*トリソウエ	(1)
4	◇02	MAS-05208000	INTERMITTENT SHIRRING PLATE		ヒタ*トリソウエ	(1)
5		SS-7090520-SP	SCREW 9/64-40 L= 4.5		マルヒラネシ* 9/64-40 L=4.5	(1)
6		MAS-09203000	SPRING PLATE		シユト* - レハ* - ハ*ネ	(1)
7		MAS-09201000	MANUAL LEVER ARM		シユト* - レハ* - ウチ*	(1)
8		SD-0640322-TP	HINGE SCREW D= 6.35 H= 3.2		タ*ンネシ* D=6.35 H=3.2	(1)
9		MAS-092020A0	MANUAL LEVER ASM.		シユト* - レハ* - クミ	(1)
10		NS-6150310-SP	NUT 15/64-28		ロツカクナツト 15/64-28	(1)
11		MAS-057010B0	PEDAL SHIRRING ATTACHMENT ASM.		ヒタ*トリソ-チ クミ	(1)
12		SS-6090650-SP	SCREW 9/64-40 L=6		ヒラネシ* 9/64-40 L=6	(2)
13		SS-8110520-TP	SCREW 11/64-40 L= 4.5		トメネシ* 11/64-40 L=4.5	(1)
14		SD-0790801-SP	HINGE SCREW D=7.94 H=8		タ*ンネシ* D=7.94 H=8	(1)
15		WZ-0850302-K0	WAVED WASHER 8.5X13X0.3		ワミカ*ワウ*カ*ネ 8.5X12.5X0.3	(1)
16		MAS-05703000	LIFTING ARM		ヒキアケ*ウチ*	(1)
17		SS-7110710-SP	SCREW 11/64-40 L=7		マルヒラネシ* 11/64-40 L=7	(2)
18		MAS-052070A0	LIFTING ARM MOUNTING BLOCK ASM. A		ヒキアケ*ウチ* トリツクタイ クミ	(1)
19		SS-6151440-SP	SCREW 15/64-28 L=14		ヒラネシ* 15/64-28 L=14	(1)
20		MAS-05204000	ARM		ヒタ*トリソウエ ハ*ネウチ*	(1)
21		MAS-05205000	SPRING		ヒタ*トリソウエハ*ネ	(1)
22		B3105-804-000	TENSION POST		イトチヨ-シネ*	(1)
23		CS-079081A-SP	THRUST COLLAR ASM. D=7.94 W=8		スラストウケ D=7.94 W=8	(1)
24		SS-8110520-TP	SCREW 11/64-40 L= 4.5		トメネシ* 11/64-40 L=4.5	(2)
25		SS-6110710-SP	SCREW 11/64-40 L=7		ヒラネシ*	(2)
26		B3120-125-000	TENSION DISC STOPPER		イトチヨ-シウラ カイテント*メ	(1)
27		B3116-125-000	TENSION NUT		イトチヨ-シ ナツト	(1)
28		MAS-05206000	SHAFT		ヒタ*トリシ*ク	(1)
29		SS-7110710-SP	SCREW 11/64-40 L=7		マルヒラネシ* 11/64-40 L=7	(1)
30		MAS-05209000	SPRING		ヒタ*トリソウエ ショ*タイハ*ネ	(1)
31		MAS-05704000	SWING BASE ROTATING STOPPER		ヒタ*トリソウエ トリツクタイ マウリト*メ	(1)
32		SS-7110510-SP	SCREW 11/64-40 L=5		マルヒラネシ* 11/64-40 L= 5	(1)
33		MAS-05212000	PIPING MOUNTING BLOCK		ハ*イヒ*ンク* トリツクタイ	(1)
34		SS-6110650-TP	SCREW 11/64-40 L=5.5		ヒラネシ* 11/64-40 L=5.5	(1)
35		MAS-05702000	SWING BASE		ヒタ*トリソウエ ショ*タイ	(1)
36		MAS-057010C0	PRESSER PLATE BASE ASM.		ヒタ*トリソウエ トリツクタイ クミ	(1)
37		SS-6120940-SP	SCREW 3/16-28 L=9		ヒラネシ* 3/16-28 L=9	(1)
38		NS-6160520-SP	NUT 1/4-24		ロツカクナツト 1/4-24	(1)
39	◇03	MAS-0510800A	INTERMITTENT SHIRRING PRESSER PLATE		ヒタ*トリソウエ	1

Note (注記) ◇01 ..... For S097  
◇02 ..... For S098  
◇03 ..... For RH6-320/S097

S097用  
S098用  
RH6-320/S097

5. KNEE OPERATING COMPONENTS  
膝作動装置関係

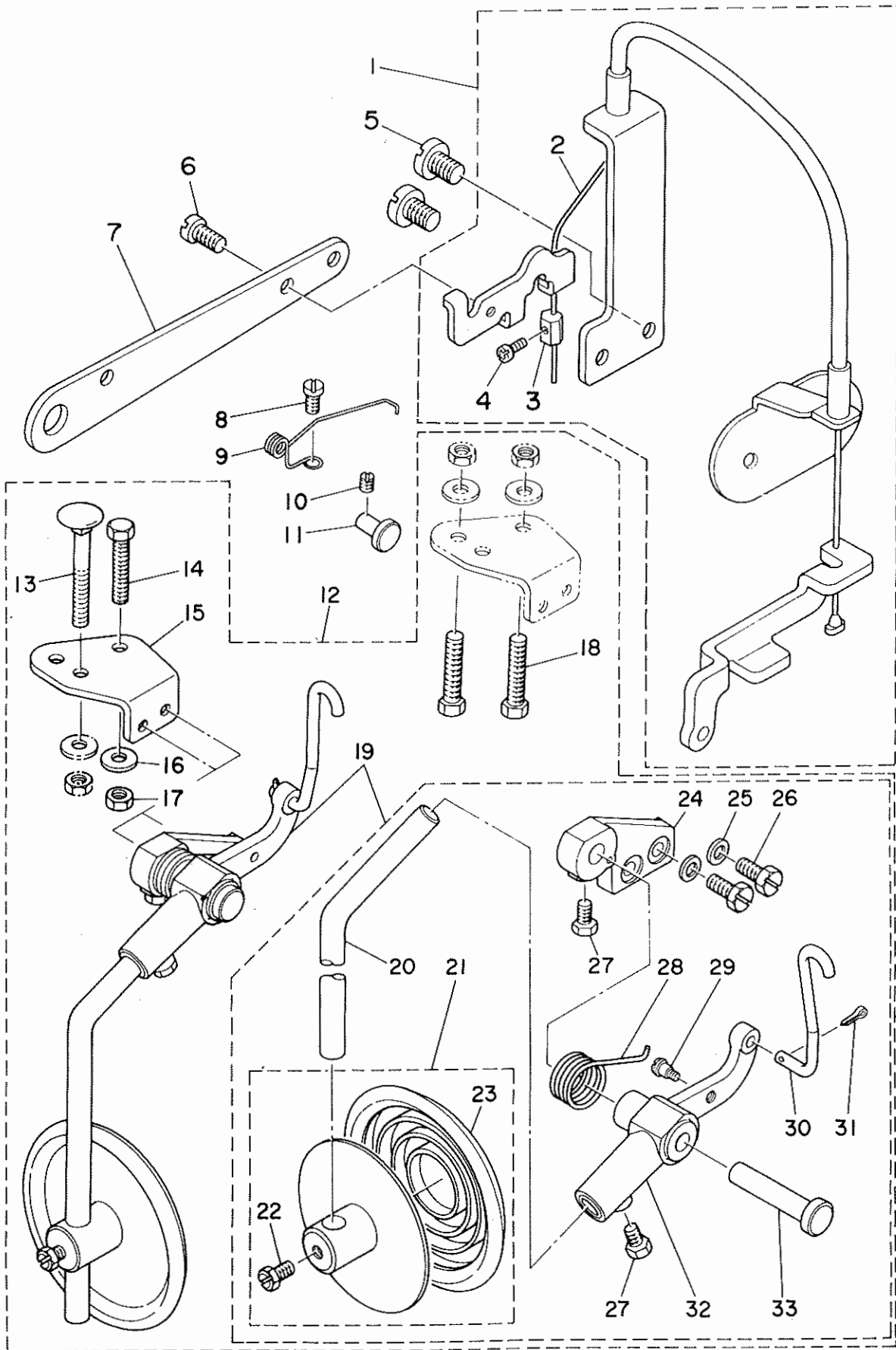

Ref. No.	Note 注記	Part No. 品番	Description	E. C. 変更年月	品名	Amt. Req. 数量
1		MAS-057050A0-A	WIRE ASM.		ワイヤークミ	1
2		MAS-057120A0	WIRE METAL FITING ASM.		ワイヤカナグクミ	(1)
3		MAS-05720000	WIRE STOPPER		ワイヤトメ	(1)
4		SS-4090615-SP	SCREW		ナベネジ	(1)
5		SS-6151040-SP	SCREW 15/64-28 L=10		ヒラネジ 15/64-28 L=10	2
6		SS-6121010-SP	SCREW 3/16-28 L=10		ヒラネジ 3/16-28 L=10	2
7		118-19307	LIFTING LEVER ASM.		オサエアカレハ	1
8		SS-6110610-TP	SCREW 11/64-40 L=6		ヒラネジ 11/64-40 L=6	1
9		MAS-05715000	SPRING		ヒキアカレハ ハネ	1
10		SS-8090410-SP	SCREW 9/64-40 L=3.5		トメネジ 9/64-40 L=3.5	1
11		MAS-05714000	PIN		ヒキアカレハ ヒツシク	1
12		MAS-107010A0	KNEE OPERATING DEVICE ASM.	C.05/84	MAS-107010C0	1
13		MAS-10704000	BOLT		ウケイタネット	(1)
14	#01	SM-9083013-SC	SCREW M8 L=30		ロツカクネット M8 L=30	(1)
15		MAS-10701000	INSTALLING PLATE		ヒキアカレハ タイツツケイ	(1)
16	#01	WP-0850002-SC	WASHER 8.5X18X1.6		ヒラサカネ 8.5X18X1.6	(1)
17	#01	NM-6080600-SM	NUT M8		ロツカクナツト M8 10X11.5	(1)
18	#02	SM-9084533-SC	SCREW M8 L=45		ロツカクネット M8 L=45	(2)
19		MAS-107010C0	KNEE PRESS PLATE ASM.	C.05/84	ヒキアタイタ クミ	(1)
20		MAS-10702000	ROD		ヒキアカシク	(1)
21		B3430-552-0AU	KNEE PRESS PLATE ASM.		ヒキアタイタ クミ	(1)
22		SS-9661230-CP	SCREW 1/4-40 L=12		ロツカクネット 1/4-40 L=12	(1)
23		B3431-552-00U-A	KNEE PRESS PLATE COVER		ヒキアタイタ カハ	(1)
24		MAS-10501000	LEVER INSTALLING BASE		ヒキアカレハ タイ	(1)
25		WP-0740510-SP	WASHER 7.4X11.8X0.5		ヒラサカネ 7.4X11.8X0.5	(2)
26		SS-9681610-TP	SCREW 9/32-28 L=16		ロツカクネット 9/32-28 L=16	(2)
27		SS-9151220-SR	SCREW 15/64-28 L=12		ロツカクネット 15/64-28 L=12	(1)
28		MAS-10503000	SPRING		ヒキアカレハ ハネ	(1)
29		SD-0550501-SP	HINGE SCREW D=5.5 H=5		タンスジ D=5.5 H=5	(1)
30		MAS-10703000	CONNECTING ROD		ヒキアカ レンケツネ	(1)
31		PD-0201000-0U	SPLIT PIN 2X10		ワリピン 1.0X10	(1)
32		MAS-10502000	LEVER		ヒキアカレハ	(1)
33		MAS-10504000	PIN		ヒキアカレハ シク	(1)

NOTE (注記) ◇01.....For semi-sunken type table  
◇02.....For fully-sunken type table

卓上式テーブル用  
全沈式テーブル用

6. S112: SWING TYPE UPPER INTERMITTENT SHIRTING ATTACHMENT  
 (MANUAL/PEDAL TYPE)  
 S112: スイング方式上ひだ取り装置 (手動・ペダル式)

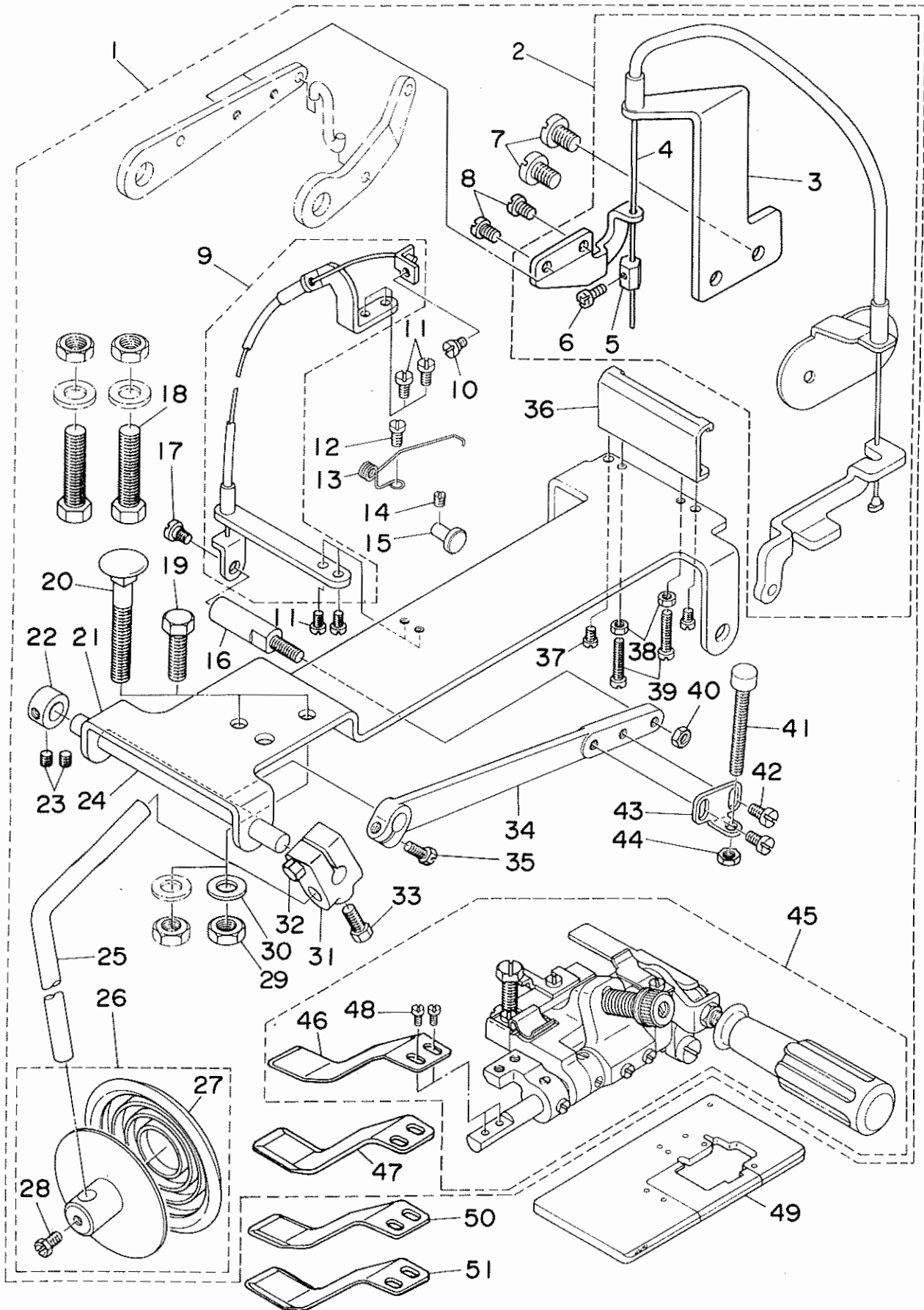

Ref. No.	Note 注記	Part No. 品番	Description	E.C. 変更年月	品名	Amt. Req. 数量
1		MAS-112000A0-A	UPPER SHIRING ATTACHMENT ASM.		ウフヒタトリツナ クミ	1
2		MAS-112120A0-A	LIFTING WIRE ASM.		オガイアケワイヤ	(1)
3		MAS-125190A0	WIRE SUPPORT ASM.		ワイヤサエ クミ	(1)
4		MAS-057120A0	WIRE METAL FITTING ASM.		ワイヤカク クミ	(1)
5		MAS-05720000	WIRE STOPPER		ワイヤトメ	(1)
6		SS-4090615-SP	SCREW		ナベジ	(1)
7		SS-6151040-SP	SCREW 15/64-28 L=10		エラネジ 15/64-28 L=10	(2)
8		SS-7110710-SP	SCREW 11/64-40 L=7		マルヒラネジ 11/64-40 L=7	(2)
9		MAS-112010A0	WIRE ASM.		ワイヤ クミ	(1)
10		SD-0500251-SP	HINGE SCREW D= 5 H= 2.5		ダブネジ D=5 H=2.5	(1)
11		SS-7110710-SP	SCREW 11/64-40 L=7		マルヒラネジ 11/64-40 L=7	(4)
12	*	SS-6110610-TP	SCREW 11/64-40 L=6	A.05/84	ヒラネジ 11/64-40 L=6	(1)
13	*	MAS-05715000	SPRING	A.05/84	ヒキアケレバ 11/64	(1)
14	*	SS-8090410-SP	SCREW 9/64-40 L= 3.5	A.05/84	トメネジ 9/64-40 L=3.5	(1)
15	*	MAS-05714000	PIN	A.05/84	ヒキアケレバ エンジンシツク	(1)
16		MAS-11206000	SHAFT A		ヒタトリシツク A	(1)
17		SD-0640321-SP	HINGE SCREW D= 6.35 H= 3.2		ダブネジ D=6.35 H=3.2	(1)
18	#02	SM-9084533-SC	SCREW M8 L=45		ロツカクネルト M8 L=45	(2)
19	#01	SM-9083013-SC	SCREW M8 L=30		ロツカクネルト M8 L=30	(1)
20	#01	MAS-10704000	BOLT		ツクイタネルト	(1)
21		MAS-11211000	LEVER BASE		ヒキアケレバ レバ	(1)
22		CS-1111019-SP	THRUST COLLAR D=11.11 W=10		スラストワケ D=11.11 W=10	(1)
23		SS-8660330-SP	SCREW 1/4-40 L= 3.0		トメネジ 1/4-40 L=3	(2)
24		MAS-11209000	SHAFT B		ヒタトリシツク B	(1)
25		MAS-10702000	ROD		ヒキアケレバ	(1)
26		B3430-552-OA0	KNEE PRESS PLATE ASM.		ヒキアケレバ クミ	(1)
27		B3431-552-000-A	KNEE PRESS PLATE COVER		ヒキアケレバ カバ	(1)
28		SS-9661230-CP	SCREW 1/4-40 L=12		ロツカクネルト 1/4-40 L=12	(1)
29	#01	NM-6080600-SM	NUT M8		ロツカクネルト M8 シツ	(1)
30	#01	WP-0850002-SC	WASHER 8.5X18X1.6		ヒラケカバ 8.5X18X1.6	(1)
31		B3427-122-000	KNEE PRESS ROD MOUNTING BRACKET		ヒキアケレバ シツク トリツクワケ	(1)
32		SS-9182010-SN	SCREW 9/32-20 L=20		ロツカクネルト 9/32-20 L=20	(1)
33		SS-9181520-CP	SCREW 9/32-20 L=15.0		ロツカクネルト 9/32-20 L=15	(1)
34		MAS-11207000	ARM		ヒタトリシツク	(1)
35		SS-9661610-CP	SCREW 1/4-40 L=16		ロツカクネルト 1/4-40 L=16	(1)
36		MAS-11210000	LEVER BASE SUPPORT		ヒキアケレバ レバ	(1)
37		SS-7110710-SP	SCREW 11/64-40 L=7		マルヒラネジ 11/64-40 L=7	(2)
38		NS-6110310-SP	NUT 11/64-40		ロツカクネルト 11/64-40	(2)
39		SS-7112420-SP	SCREW 11/64-40 L=24		マルヒラネジ 11/64-40 L=24	(2)
40		NS-6150310-SP	NUT 15/64-28		ロツカクネルト 15/64-28	(1)
41		GAK-01003B00	PRESSER LIFTER STOPPER B		オガイアケレバ ストップ B	(1)
42		SS-7151210-SP	SCREW 15/64-28 L=12		マルヒラネジ 15/64-28 L=12	(2)
43		MAS-11208000	STPPER BASE		ヒタトリ ストップ	(1)
44		NM-6060003-SC	NUT M6		ロツカクネルト M6 シツ	(1)
45		MAS-112140A0	UPPER SHIRING ATTACHMENT ASM.		ヒタトリツナ クミ	(1)
46	#03	MAS-12523000	SEPARATING PLATE A T=0.8	A.06/88	ヒタトリ フツリヤ A	(1)
47	#04	MAS-12524000	SEPARATING PLATE B T=1.6	A.06/88	ヒタトリ フツリヤ B	(1)
48		SS-6090650-SP	SCREW 9/64-40 L=6		ヒラネジ 9/64-40 L=6	(2)
49	#01	118-95950	TABLE B (FULLY SUNKEN TYPE)		テーブル B クミ (ヒツツツ)	1
50	#05	MAS-12525000	SEPARATING PLATE C T=1.2	A.06/88	ヒタトリ フツリヤ C	1
51	#05	MAS-12526000	SEPARATING PLATE D T=2.0	A.06/88	ヒタトリ フツリヤ D	1

Note (注記) #01 ..... For semi-sunken type table  
#02 ..... For fully-sunken type table  
#03 ..... Standard part  
#04 ..... Accessory part  
#05 ..... Special order part

卓上式テーブル用  
全沈式テーブル用  
標準品  
付属品  
特別注文部品

7. S114, S115: SWING TYPE LOWER INTERMITTENT SHIRRING ATTACHMENT  
 S114, S115: スイング方式布ひだ取り装置

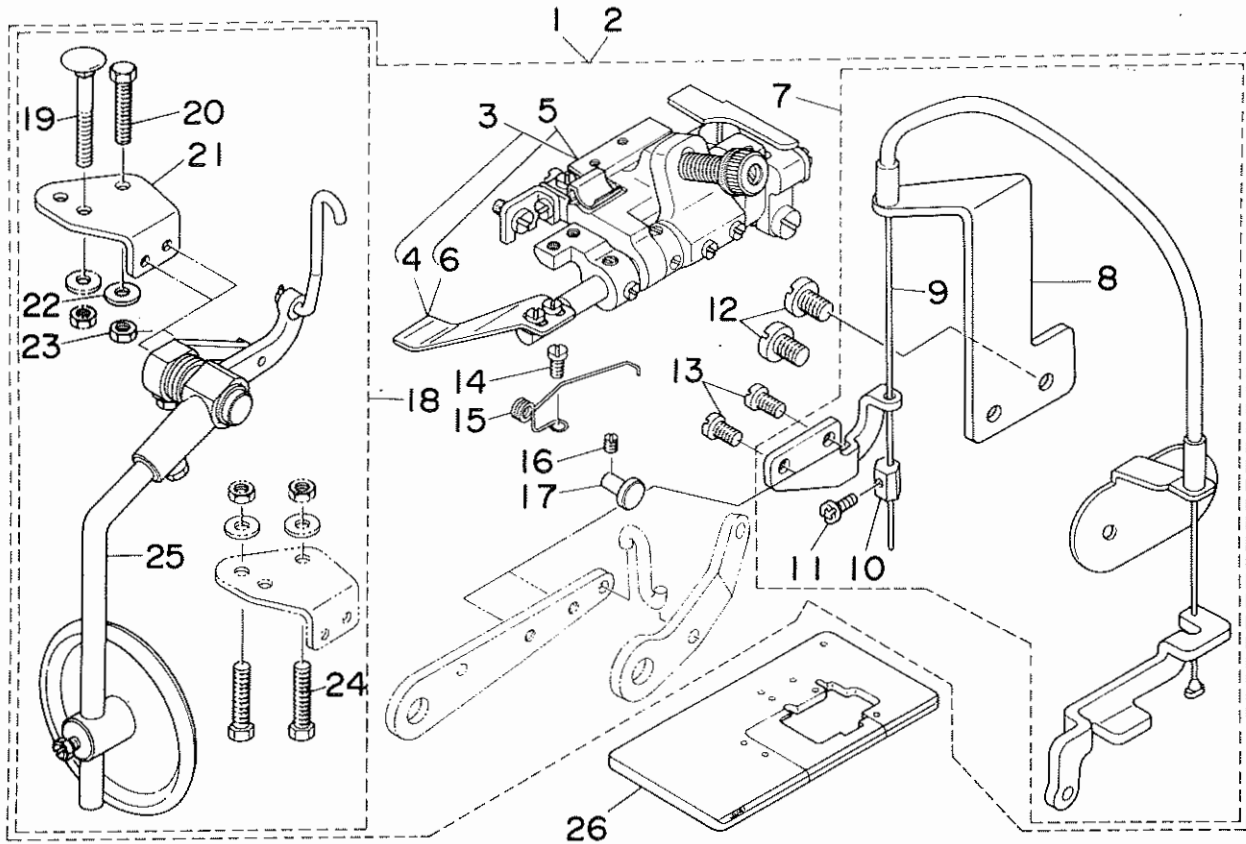

Ref. No.	Note 注記	Part No. 品番	Description	E. C. 変更年月	品名	Amt. Req. 数量
1	#01	MAS-114000A0-A	LOWER SHIRRING ATTACHMENT ASM.		ヒタトリソウチ クミ	1
2	#02	MAS-115000A0-A	LOWER SHIRRING ATTACHMENT ASM.		ヒタトリソウチ クミ	1
3	#01	MAS-057010A0	PEDAL SHIRRING ATTACHMENT ASM.		ヒタトリソウチ クミ	(1)
4	#01	MAS-05108000	INTERMITTENT SHIRRING PRESSER PLATE		ヒタトリソウチ	(1)
5	#02	MAS-058010A0	PEDAL SHIRRING ATTACHMENT ASM.		ヒタトリソウチ クミ	(1)
6	#02	MAS-05208000	INTERMITTENT SHIRRING PLATE		ヒタトリソウチ	(1)
7		MAS-112120A0-A	LIFTING WIRE ASM.		オウエアケワイヤ	(1)
8		MAS-125190A0	WIRE SUPPORT ASM.		ワイヤサエ クミ	(1)
9		MAS-057120A0	WIRE METAL FITTING ASM.		ワイヤカタ クミ	(1)
10		MAS-05720000	WIRE STOPPER		ワイヤトメ	(1)
11		SS-4090615-SP	SCREW		ナベジ	(1)
12		SS-6151040-SP	SCREW 15/64-28 L=10		ヒラネジ 15/64-28 L=10	(2)
13		SS-7110710-SP	SCREW 11/64-40 L=7		マルヒラネジ 11/64-40 L=7	(2)
14		SS-6110610-TP	SCREW 11/64-40 L=6		ヒラネジ 11/64-40 L=6	(1)
15		MAS-05715000	SPRING	A.05/84	Eキアケレハ - ハネ	(1)
16		SS-8090410-SP	SCREW 9/64-40 L=3.5	A.05/84	トメネジ 9/64-40 L=3.5	(1)
17		MAS-05714000	PIN	A.05/84	Eキアケレハ - ヒジシキク	(1)
18		MAS-107010A0	KNEE OPERATING DEVICE ASM.	C.05/84	MAS-107010C0	(1)
19	#03	MAS-10704000	BOLT		ウケイタネルト	(1)
20	#03	SM-9083013-SC	SCREW M8 L=30		ロツカクネルト M8 L=30	(1)
21		MAS-10701000	INSTALLING PLATE		ヒツアケレハ - タイ トリツガイ	(1)
22	#03	WP-0850002-SC	WASHER 8.5X18X1.6		ヒラサカネ 8.5X18X1.6	(1)
23	#03	NH-6080600-SM	NUT M8		ロツカクワツト M8 10X11.5	(1)
24	#04	SM-9084533-SC	SCREW M8 L=45		ロツカクネルト M8 L=45	(2)
25		MAS-107010C0	KNEE PRESS PLATE ASM.	C.05/84	MAS-107010A0	(1)
26		118-95950	TABLE B (FULLY SUNKEN TYPE)		チーフル B クミ (セリソウチ)	1

Note (注記) #01 ..... For S114  
 #02 ..... For S115  
 #03 ..... For semi-sunken type table  
 #04 ..... For fully-sunken type table

S114用  
 S115用  
 卓上式テーブル用  
 全沈式テーブル用

8. SIMULTANEOUS EXCHANGING GAUGE PARTS (FOR MOR-2500N SERIES)  
MOR-2500N シリーズ同時交換ゲージ部品

(1) S112

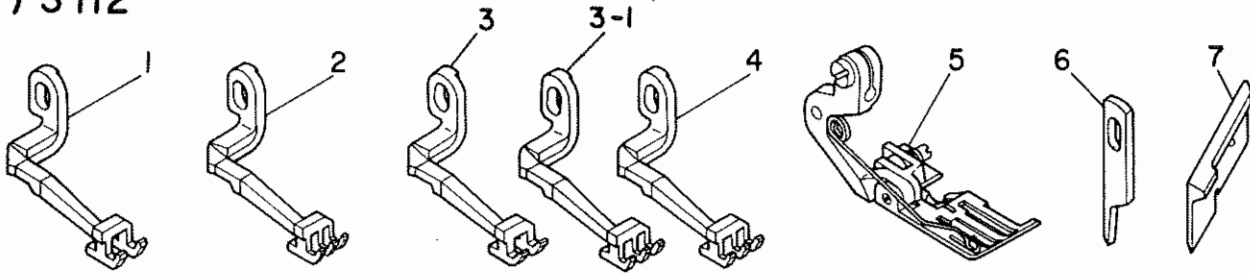

Ref. No.	Note 注記	Part No. 品番	Description	E. C. 変更年月	品名	Amt. Req. 数量
1	#01	119-37505	UPPER FEED DOG		ウウオクリハ	1
2	#02	119-37604	UPPER FEED DOG		ウウオクリハ	1
3	#03	119-37703	UPPER FEED DOG		ウウオクリハ	1
3-1	#06	119-36408	UPPER FEED DOG	A.06/88	ウウオクリハ	1
4	#04	119-37802	UPPER FEED DOG		ウウオクリハ	1
5	#03	119-34056	PRESSER FOOT ASM.		オウエ クミ	1
6	#03	118-45609	KNIFE		ヒラメス	1
7	#05	118-45906	UPPER KNIFE		ウウメス	1

NOTE (注記) #01..... For MOR-2514N-BD4 MOR-2514N-BD4用  
 #02..... For MOR-2514N-BD6 MOR-2514N-BD6用  
 #03..... For MOR-2516N-DD4 MOR-2516N-DD4用  
 #04..... For MOR-2516N-FF6, MOR-2516N-RH6 MOR-2516N-FF6, MOR-2516N-RH6用  
 MOR-2543N-DBD6 MOR-2543N-DBD6用  
 #05..... For MOR-2516N-DD4 (For export) MOR-2516N-DD4 (輸出用)  
 #06..... For MOR-2516N-DD6 MOR-2516N-DD6用

(2) S114, S098

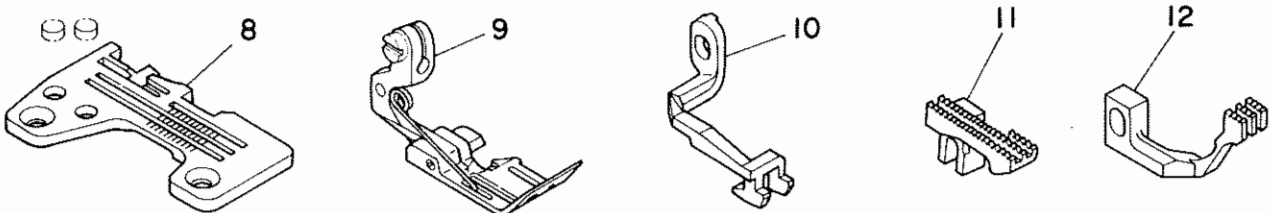

Ref. No.	Note 注記	Part No. 品番	Description	E. C. 変更年月	品名	Amt. Req. 数量
8		R4305-H0D-E0A	THROAT PLATE		ハリイタ	1
9		119-35053	PRESSEP FOOT ASM.		オウエ クミ	1
10		119-38602	UPPER FEED DOG		ウウオクリハ	1
11		118-83402	MAIN FEED DOG		ジュオクリハ	1
12		B1657-814-B0L	DIFFERENTIAL FEED DOG		フクオクリハ	1

(3) S115, S097

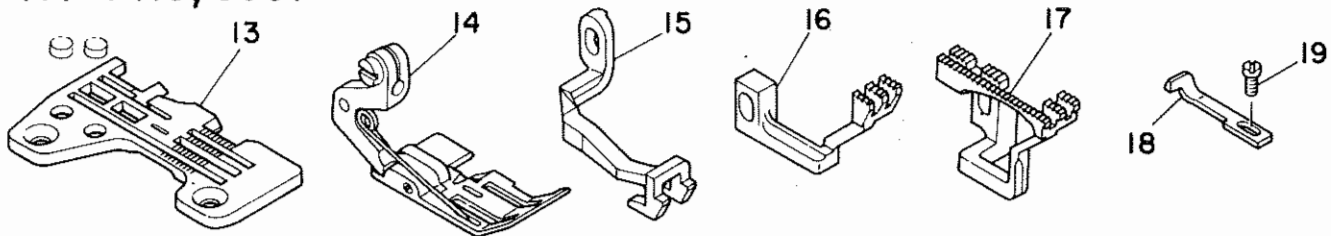

Ref. No.	Note 注記	Part No. 品番	Description	E. C. 変更年月	品名	Amt. Req. 数量
13		R4612-H0F-B00	THROAT PLATE		ハリイタ	1
14		119-35152	PRESSEP FOOT ASM.		オウエ クミ	1
15		119-38701	UPPER FEED DOG		ウウオクリハ	1
16		118-85902	DIFFERENTIAL FEED DOG		フクオクリハ	1
17		118-84103	MAIN FEED DOG		ジュオクリハ	1
18		B4120-816-F0C-A	NEEDLE GUARD		ハリウケ E	1
19		SS-7060610-SP	SCREW 3/32-56 L=5.5		マルヒラネジ 3/32-56 L=5.5	1

9. S118, S119: SWING TYPE UPPER INTERMITTENT SHIRTING ATTACHMENT  
 (PEDAL TYPE)  
 S118, S119: スイグ方式上ひだ取り装置 (ペダル式)

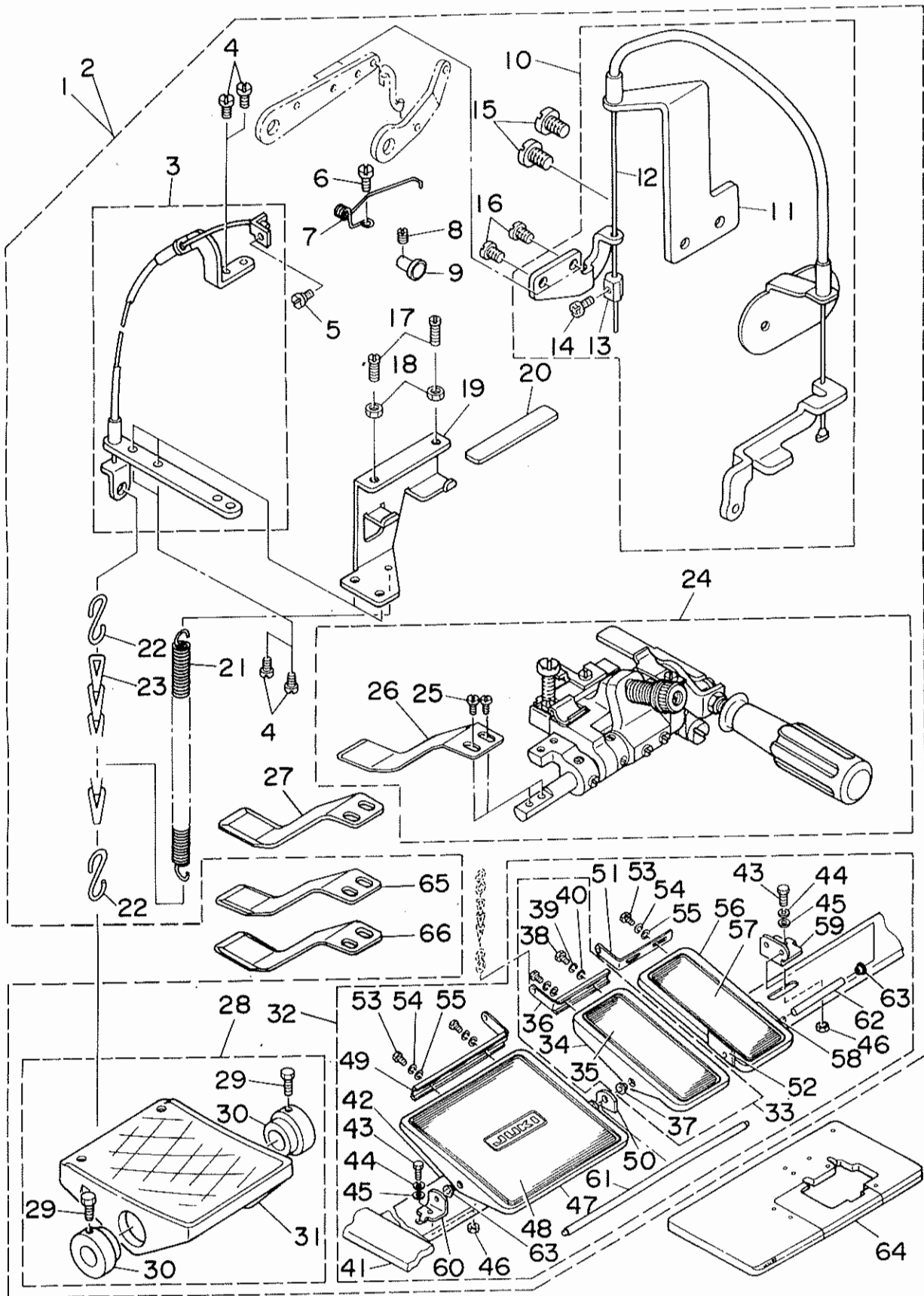



Ref. No.	Note 注記	Part No. 品番	Description	E.C. 変更年月	品名	Amt. Req. 数量
1	#01	MAS-118000AO-A	UPPER SHIRRING ATTACHMENT ASM.		ウフヒタトリソチ クミ	1
2	#02	MAS-119000AO-A	UPPER SHIRRING ATTACHMENT ASM.		ウフヒタトリソチ クミ	1
3		MAS-112010AO	WIRE ASM.		ワイヤ クミ	(1)
4		SS-7110710-SP	SCREW 11/64-40 L=7		マムヒラネシ 11/64-40 L=7	(4)
5		SD-0500251-SP	HINGE SCREW D=5 H=2.5		ダツネシ D=5 H=2.5	(1)
6		SS-6110610-TP	SCREW 11/64-40 L=6		ヒラネシ 11/64-40 L=6	(1)
7		MAS-05715000	SPRING		ヒキアケリハハハ	(1)
8		SS-8090410-SP	SCREW 9/64-40 L=3.5		トメネシ 9/64-40 L=3.5	(1)
9		MAS-05714000	PIN		ヒキアケリハハハ ヒンジツク	(1)
10		MAS-112120AO-A	LIFTING WIRE ASM.		オサアケツワイヤ	(1)
11		MAS-125190AO	WIRE SUPPORT ASM.		ワイヤササ クミ	(1)
12		MAS-057120AO	WIRE METAL FITTING ASM.		ワイヤカナダ クミ	(1)
13		MAS-05720000	WIRE STOPPER		ワイヤトメ	(1)
14		SS-4090615-SP	SCREW		ナベネジ	(1)
15		SS-6151040-SP	SCREW 15/64-28 L=10		ヒラネシ 15/64-28 L=10	(1)
16		SS-7110710-SP	SCREW 11/64-40 L=7		マムヒラネシ 11/64-40 L=7	(1)
17		SS-6111110-SP	SCREW 11/64-40 L=11.0		ヒラネシ 11/64-40 L=11	(2)
18		NS-6110310-SP	NUT 11/64-40		ワツカクナツト 11/64-40	(2)
19		MAS-11801000	WIRE STOPPER SUPPORTER		ワイヤストツク サダササ	(1)
20		MAS-11802000	PROTECTOR PLATE		ソウフウケース ネジ	(1)
21		U7159-781-000	SHIFTER TENSION SPRING		シフター ヒツハリハハ	(1)
22		B8133-019-000	S SHAPED HOOK		Sカクタ カク	(2)
23		B8301-804-000	CHAIN		クワリ	(1)
24		MAS-112140AO	UPPER SHIRRING ATTACHMENT ASM.		ヒタトリソチ クミ	(1)
25		SS-6090650-SP	SCREW 9/64-40 L=6		ヒラネシ 9/64-40 L=6	(2)
26	#04	MAS-12523000	SEPARATING PLATE A T=0.8	A.06/88	ヒタトリ フツリヤ A	(1)
27	#05	MAS-12524000	SEPARATING PLATE B T=1.6	A.06/88	ヒタトリ フツリヤ B	(1)
28	#02	B8101-232-0AO	PEDAL ASM.		ハタタ クミ	(1)
29	#02	SM-906 703-SE	SCREW M6 L=12		ワツカクネツト M6 L=12	(2)
30	#02	B8125-112-000	PEDAL THRUST COLLAR		フミヤ ササツク	(2)
31	#02	B8101-232-000	PEDAL		ハタタ	(1)
32	#01	MAS-118000BO	PEDAL ASM.		ハタタ クミ	(1)
33	#01	MAS-118030AO	PEDAL ASM.		オサアケツハタタ クミ	(1)
34	#01	B8151-771-000	PEDAL		Zキヤクヨハタタ	(1)
35	#01	B8152-771-000	PEDAL MAT		ハタタマツ	(1)
36	#01	D8125-772-B00	PEDAL ADJUSTING PLATE		フミヤ チョセツヤ	(1)
37	#01	O8113-555-B00	PEDAL BUSHING		フミヤ フツツ	(2)
38	#01	SM-9061203-SE	SCREW M6 L=12		ワツカクネツト M6 L=12	(2)
39	#01	WS-0621210-KR	SPRING WASHER 6.2X11.4X1.2		ハタタカネ 6.2X11.4X1.2	(2)
40	#01	WP-0671016-SE	WASHER 6.7X13X1		ヒラカネ 6.7X13X1	(2)
41	#01	B8103-552-000	STAND ASM.		シフター クミ	(2)
42	#01	O8109-555-B00	PEDAL SHAFT		シタシチュー	(1)
43	#01	SM-9082023-SE	SCREW M8 L=20		ワツカクネツト M8 L=20	(3)
44	#01	WS-0861410-KR	SPRING WASHER 8.6X15X1.4		ハタタカネ 8.6X15X1.4	(3)
45	#01	WP-0871602-SE	WASHER 8.7X18X1.6		ヒラカネ 8.7X18X1.6	(6)
46	#01	NM-6080721-SE	NUT M8		ワツカクナツト M8	(3)
47	#01	O8110-555-BOE	PEDAL		フミヤ	(1)
48	#01	O8111-555-BOE	PEDAL MAT		フミヤ マツ	(1)
49	#01	O8112-555-BOE	PEDAL ADJUSTING PLATE		フミヤ チョセツヤ	(1)
50	#01	GPF-01017000	LINER PLATE		フミヤシツク	(1)
51	#01	O8125-772-B00	PEDAL ADJUSTING PLATE		フミヤ チョセツヤ	(1)
52	#01	B8153-491-000	PEDAL SUPPORT PLATE B		ハタタシツヤ B	(1)
53	#01	SM-9061203-SE	SCREW M6 L=12		ワツカクネツト M6 L=12	(4)
54	#01	WS-0621210-KR	SPRING WASHER 6.2X11.4X1.2		ハタタカネ 6.2X11.4X1.2	(4)
55	#01	WP-0671016-SE	WASHER 6.7X13X1		ヒラカネ 6.7X13X1	(4)
56	#01	B8151-491-000	PEDAL		ハタタ	(1)
57	#01	B8152-771-000	PEDAL MAT		ハタタマツ	(1)
58	#01	B8152-491-000	PEDAL SUPPORT PLATE A		ハタタシツヤ A	(1)
59	#01	B8114-491-000	PEDAL SHAFT BRACKET		フミヤシツク	(2)
60	#01	O8114-555-BOE	PEDAL SHAFT BRACKET		フミヤシツク	(1)
61	#01	GPF-01016000	PEDAL SHAFT		ハタタシツク	(1)
62	#01	B8115-491-000	PEDAL SHAFT		ハタタシツク	(1)
63	#01	O8113-555-B00	PEDAL BUSHING		フミヤ フツツ	(4)
64	#03	118-95950	TABLE B (FULLY SUNKEN TYPE)		テーブ B クミ (フルンケン)	1
65	#06	MAS-12525000	SEPARATING PLATE C T=1.2	A.06/88	ヒタトリ フツリヤ C	1
66	#06	MAS-12526000	SEPARATING PLATE D T=2.0	A.06/88	ヒタトリ フツリヤ D	1

Note (注記) #01.....For S118 S118用  
#02.....For S119 S119用  
#03.....For fully-sunken type table 全沈式テーブル用  
#04.....Standard part 標準品  
#05.....Accessory part 付属品  
#06.....Special order part 特別注文部品

NUMERICAL INDEX OF PARTS

索引

Part No. 品番	Page Ref. 頁 No.	Part No. 品番	Page Ref. 頁 No.	Part No. 品番	Page Ref. 頁 No.	Part No. 品番	Page Ref. 頁 No.
B1657-814-BOL	2 25	MAS-057120AO	14 12	PD-0201000-OD	8 31	WP-0671016-SE	14 40
B1657-814-BOL	12 12	MAS-05714000	1 5	R4300-HOD-DOA	2 23	WP-0671016-SE	14 55
B3105-804-000	4 17	MAS-05714000	8 11	R4305-HOD-EOA	2 22	WP-0740516-SP	8 25
B3105-804-000	6 22	MAS-05714000	10 15	R4305-HOD-EOA	12 8	WP-0850002-SC	1 13
B3116-125-000	4 22	MAS-05714000	11 17	R4612-HOF-800	2 5	WP-0850002-SC	8 16
B3116-125-000	6 27	MAS-05714000	14 9	R4612-HOF-800	12 13	WP-0850002-SC	10 30
B3120-125-000	4 21	MAS-05715000	1 8	SD-0500251-SP	10 10	WP-0850002-SC	11 22
B3120-125-000	6 26	MAS-05715000	8 9	SD-0500251-SP	14 5	WP-0871602-SE	14 45
B3427-122-000	10 31	MAS-05715000	10 13	SD-0550501-SP	8 29	WS-0621210-KR	14 39
B3430-552-0AO	8 21	MAS-05715000	11 15	SD-0640321-SP	10 17	WS-0621210-KR	14 54
B3430-552-0AO	10 26	MAS-05720000	14 7	SD-0640322-TP	6 8	WS-0861410-KR	14 44
B3431-552-000-A	8 23	MAS-05720000	8 3	SD-0790801-SP	4 10	WZ-0850302-KO	4 9
B3431-552-000-A	10 27	MAS-05720000	10 5	SD-0790801-SP	6 14	WZ-0850302-KO	6 15
B4120-816-DOB-A	2 8	MAS-05720000	11 10	SM-9061203-SE	14 29	118-19307	1 4
B4120-816-FDC-A	2 9	MAS-05720000	14 13	SM-9061203-SE	14 38	118-19807	8 7
B4120-816-FDC-A	12 18	MAS-058010AO	4 2	SM-9061203-SE	14 53	118-45609	2 7
B4120-816-ROA	2 10	MAS-058010AO	11 5	SM-9082023-SE	14 43	118-45609	12 6
B7159-781-000	14 21	MAS-09201000	6 7	SM-9083013-SC	1 11	118-45807	2 6
B8101-232-000	14 31	MAS-092020AO	6 9	SM-9083013-SC	8 14	118-45906	12 7
B8101-232-0AO	14 28	MAS-09203000	6 6	SM-9083013-SC	10 19	118-78857	2 21
B8103-552-000	14 41	MAS-097010AO	6 1	SM-9083013-SC	11 20	118-78857	2 21-1
B8114-491-000	14 59	MAS-098010AO	6 2	SM-9084533-SC	1 15	118-79305	2 20
B8115-491-000	14 62	MAS-10501000	8 24	SM-9084533-SC	8 18	118-79368	2 20-1
B8125-012-000	14 30	MAS-10502000	8 32	SM-9084533-SC	10 18	118-79558	2 1
B8133-019-000	14 22	MAS-10503000	8 28	SM-9084533-SC	11 24	118-79566	2 1-1
B8151-491-000	14 56	MAS-10504000	8 33	SM-9084533-SP	8 4	118-79657	2 2
B8151-771-000	14 34	MAS-10701000	1 12	SS-4090615-SP	10 6	118-79666	2 2-1
B8152-491-000	14 58	MAS-10701000	8 15	SS-4090615-SP	11 11	118-80457	2 3
B8152-771-000	14 35	MAS-107010AO	1 9	SS-4090615-SP	14 14	118-80465	2 3-1
B8152-771-000	14 57	MAS-107010AO	8 12	SS-6090650-SP	4 6	118-80853	2 4
B8153-491-000	14 52	MAS-107010AO	11 18	SS-6090650-SP	6 12	118-80861	2 4-1
B8301-804-000	14 23	MAS-107010CO	1 16	SS-6090650-SP	10 48	118-83402	2 24
CS-07081A-SP	4 18	MAS-107010CO	8 19	SS-6090650-SP	14 25	118-83402	12 11
CS-079081A-SP	6 23	MAS-107010CO	11 25	SS-6110610-TP	1 7	118-83709	2 13
CS-1111019-SP	10 22	MAS-10702000	8 20	SS-6110610-TP	10 12	118-83808	2 14
D8109-555-BOO	14 42	MAS-10702000	10 25	SS-6110610-TP	11 14	118-83907	2 15
D8110-555-BOE	14 47	MAS-10703000	8 30	SS-6110610-TP	14 6	118-84103	2 16
D8111-555-BOE	14 48	MAS-10704000	1 10	SS-6110650-TP	4 29	118-84103	12 17
D8112-555-BOE	14 49	MAS-10704000	8 13	SS-6110710-SP	6 34	118-85704	2 17
D8113-555-BO	14 37	MAS-10704000	10 20	SS-6110710-SP	6 25	118-85803	2 18
D8113-555-BOO	14 63	MAS-112000AO-A	10 1	SS-6110710-TP	4 20	118-85902	2 19
D8114-555-BOE	14 60	MAS-112010AO	10 9	SS-6111110-SP	14 17	118-85902	12 16
D8125-772-BOO	14 36	MAS-112010AO	14 3	SS-61160610-TP	8 8	118-95950	10 49
D8125-772-BOO	14 51	MAS-11206000	10 16	SS-6120940-SP	4 31	118-95950	11 26
GAK-01003800	10 41	MAS-11207000	10 34	SS-6120940-SP	6 37	118-95950	14 64
GPF-01016000	14 61	MAS-11208000	10 43	SS-6121010-SP	8 6	118-97501	2 26
GPF-01017000	14 50	MAS-11209000	10 24	SS-6151040-SP	1 3	119-34056	12 5
MAS--57010BO	4 5	MAS-11210000	10 36	SS-6151040-SP	8 5	119-35053	12 9
MAS-05108000	4 3	MAS-11210000	10 21	SS-6151040-SP	10 7	119-35152	12 14
MAS-05108000	6 3	MAS-112120AO	11 7	SS-6151040-SP	11 12	119-36408	12 3-1
MAS-05108000	11 4	MAS-112120AO-A	10 2	SS-6151040-SP	14 15	119-37505	12 1
MAS-0510800A	2 12	MAS-112140AO	14 10	SS-6151440-SP	4 14	119-37604	12 2
MAS-0510800A	4 33	MAS-112140AO	10 45	SS-6151440-SP	6 19	119-37703	12 3
MAS-0510800A	6 39	MAS-112140AO	14 24	SS-7060610-SP	2 11	119-37802	12 4
MAS-05204000	4 15	MAS-114000AO-A	11 1	SS-7060610-SP	12 19	119-38602	12 10
MAS-05204000	6 20	MAS-115000AO-A	11 2	SS-7090520-SP	6 5	119-38701	12 15
MAS-05205000	4 16	MAS-118000AO-A	14 1	SS-7110510-SP	4 27		
MAS-05205000	6 21	MAS-118000BO	14 32	SS-7110510-SP	6 32		
MAS-05206000	4 23	MAS-11801000	14 19	SS-7110710-SP	1 2		
MAS-052070AO	4 13	MAS-11802000	14 20	SS-7110710-SP	4 12		
MAS-052070AO	6 18	MAS-118030AO	14 33	SS-7110710-SP	4 24		
MAS-05208000	4 4	MAS-119000AO-A	14 2	SS-7110710-SP	6 17		
MAS-05208000	6 4	MAS-125190AO	10 3	SS-7110710-SP	6 29		
MAS-05208000	11 6	MAS-125190AO	11 8	SS-7110710-SP	10 8		
MAS-05209000	4 25	MAS-125190AO-A	14 11	SS-7110710-SP	10 11		
MAS-05212000	6 30	MAS-12523000	10 46	SS-7110710-SP	10 37		
MAS-05212000	4 28	MAS-12523000	14 26	SS-7110710-SP	11 13		
MAS-05212000	6 33	MAS-12524000	10 47	SS-7110710-SP	14 4		
MAS-05701000	4 30	MAS-12524000	14 27	SS-7112420-SP	10 39		
MAS-05701000	6 36	MAS-12525000	10 50	SS-7151210-SP	10 42		
MAS-057010AO	1 17	MAS-12525000	14 65	SS-8090410-SP	1 6		
MAS-057010AO	1 18	MAS-12526000	10 51	SS-8090410-SP	8 10		
MAS-057010AO	4 1	MAS-12526000	14 66	SS-8090410-SP	10 14		
MAS-057010AO	11 3	NM-6060003-SC	10 44	SS-8090410-SP	11 16		
MAS-057010BO	6 11	NM-6080600-SC	1 14	SS-8110520-TP	4 7		
MAS-05702000	4 8	NM-6080600-SM	8 17	SS-8110520-TP	4 19		
MAS-05702000	6 35	NM-6080600-SM	10 29	SS-8110520-TP	6 13		
MAS-05703000	4 11	NM-6080721-SE	14 46	SS-8110520-TP	6 24		
MAS-05703000	6 16	NS-6110310-SP	10 38	SS-8110520-TP	10 23		
MAS-05704000	4 26	NS-6110310-SP	14 18	SS-9151220-SR	8 27		
MAS-05704000	6 31	NS-6150310-SP	6 10	SS-9181520-CP	10 33		
MAS-057050AO	8 1	NS-6150310-SP	10 40	SS-9182010-SN	10 32		
MAS-057050AO-A	1 1	NS-6160520-SP	4 32	SS-9661230-CP	8 22		
MAS-057120AO	8 2	NS-6160520-SP	6 38	SS-9661230-CP	10 28		
MAS-057120AO	10 4			SS-9661610-CP	10 35		
MAS-057120AO	11 9			SS-9681610-TP	8 26		



**JUKI**

JUKI CORPORATION

JUKI 株式会社

