PFAFF[®] **1442**

Unterklassen-Ausstattung

Subclass parts

Composition des sous-classes

Composición de las subclases

Unterklasse Sub-classe Subclasse	Ausführung Model Version Tipo de máquina	Nadelabstand in mm Needle gauge in mm Ecartement des aiguilles en mm Distance entre agujas en mm	Nadelhalter ¹⁰² Needle holder Pince-aiguille Portaagujas	Stoffschieber ⁴ ¹⁰¹ ¹⁰² Feed dog Griffe Transportador inferior
-6/01	BN	1,2-40,0	91-176343-93 ¹⁰ = 1,2-2,8 mm ⁴¹ = 3,2 mm 91-176068-93 ¹⁰ = 3,2-4,0 mm 91-172590-93 ¹⁰ = 4,8-7,2 mm 91-172840-93 ¹⁰ = 8,0-14,0 mm 91-710004-93 ¹⁰ = 15,2-34,0 mm 91-710234-93 ¹⁰ = 36,0-40,0 mm	91-047563-04 ¹⁰ = 1,2-2,2 mm ⁴¹ = 3,2 mm 91-047563-04 ¹⁰ = 2,4-4,0 mm 91-047565-04 ¹⁰ = 4,8-40,0 mm
-6/01-900/56;/61	BN	1,2-24,0	91-176343-93 ¹⁰ = 1,2-2,8 mm ⁴¹ = 3,2 mm 91-176068-93 ¹⁰ = 3,2-4,4 mm 91-172590-93 ¹⁰ = 4,8-7,2 mm 91-172840-93 ¹⁰ = 8,0-14,0 mm 91-710004-93 ¹⁰ = 15,2-24,0 mm	91-059312-04 ¹⁰ = 1,2-2,8 mm ⁴¹ = 3,2 mm 91-059313-04 ¹⁰ = 3,2-24,0 mm
-6/01	CN	2,2-40,0	91-118195-93 ¹⁰ = 2,2-2,8 mm ⁴¹ = 3,2 mm 91-710004-93 ¹⁰ = 3,2-34,0 mm 91-710234-93 ¹⁰ = 36,0-40,0 mm	91-047563-04 ¹⁰ = 2,2-2,8 mm ⁴¹ = 3,2 mm 91-047563-04 ¹⁰ = 3,2-4,0 mm 91-047565-04 ¹⁰ = 4,8-40,0 mm
-6/01-900/56;/61	CN	2,2-24,0	91-118195-93 ¹⁰ = 2,2-2,8 mm ⁴¹ = 3,2 mm 91-710004-93 ¹⁰ = 3,2-24,0 mm	91-059312-04 ¹⁰ = 2,2-2,8 mm ⁴¹ = 3,2 mm 91-059313-04 ¹⁰ = 3,2-4,4 mm 91-059313-04 ¹⁰ = 4,8-5,6 mm (C 2,0) 91-059313-04 ¹⁰ = 6,0-24,0 mm
-6/03	BN	4,0-40,0	91-176068-93 ¹⁰ = 4,0 mm 91-172590-93 ¹⁰ = 4,8-7,2 mm 91-172840-93 ¹⁰ = 8,0-14,0 mm 91-710004-93 ¹⁰ = 15,2-34,0 mm 91-710234-93 ¹⁰ = 36,0-40,0 mm	91-047563-04 ¹⁰ = 4,0 mm 91-047565-04 ¹⁰ = 4,8-40,0 mm
-6/03-900/56;/61	BN	4,0-24,0	91-176064-93 ¹⁰ = 4,0 mm 91-172590-93 ¹⁰ = 4,8-7,2 mm 91-172840-93 ¹⁰ = 8,0-14,0 mm 91-710004-93 ¹⁰ = 15,2-24,0 mm	91-059313-04 ¹⁰ = 4,0-24,0 mm
-6/03	CN	4,0-40,0	91-710004-93 ¹⁰ = 4,0-40,0 mm	91-047563-04 ¹⁰ = 4,0 mm 91-047565-04 ¹⁰ = 4,8-40,0 mm
-6/03-900/56;/61	CN	4,0-24,0	91-710004-93 ¹⁰ = 4,0-24,0 mm	91-059313-04
-19/01	BN	4,8-12,0	91-172590-93 ¹⁰ = 4,8-7,2 mm 91-172840-93 ¹⁰ = 8,0-12,0 mm	91-047565-04
-19/01-900/56;/61	BN	4,8-12,0	91-172590-93 ¹⁰ = 4,8-7,2 mm 91-172840-93 ¹⁰ = 8,0-12,0 mm	91-059313-04
-19/01	CN	4,8-12,0	91-710004-93 ¹⁰ = 4,8-12,0 mm	91-047565-04
-19/01-900/56;/61	CN	4,8-12,0	91-710004-93 ¹⁰ = 4,8-12,0 mm	91-059313-04

**Equipement des sous-classes
Unterklassen-Ausstattung**

**Dotación de las subclases
Subclass organization**

Unterklasse Subclass Sous-classe Subclase	Ausführung Model Version Tipo de máquina	Suchplatte (102) (102) Needle plate Plaque à aiguille Placa de aguja	Mähfuß (102) Presser foot Pied presseur Pie prensateijas	Apparat (5) Attachment Appareil Aparato	Träger Bracket Support Soporte
-6/01	BN	91-158 514-04 $\overline{10}$ = 1,2 - 2,2 mm $\overline{41}$ = 3,2 mm 91-158 514-04 $\overline{10}$ = 2,4 - 4,0 mm 91-158 515-04 $\overline{10}$ = 4,8 - 40,0 mm	91-054 922-03 $\overline{10}$ = 1,2 - 4,0 mm $\overline{41}$ = 3,2 mm 91-054 926-03 $\overline{10}$ = 4,8 - 14,0 mm 91-054 927-03 $\overline{10}$ = 15,2 - 40,0 mm		
-6/01-900/56; /61	BN	91-158 815-04 $\overline{10}$ = 1,2 - 2,8 mm $\overline{41}$ = 3,2 mm 91-158 811-04 $\overline{10}$ = 3,2 - 24,0 mm	91-054 922-03 $\overline{10}$ = 1,2 - 4,0 mm $\overline{41}$ = 3,2 mm 91-054 926-03 $\overline{10}$ = 4,4 - 14,0 mm 91-054 927-03 $\overline{10}$ = 15,2 - 24,0 mm		
-6/01	CN	91-158 514-04 $\overline{10}$ = 2,2 - 2,8 mm $\overline{41}$ = 3,2 mm 91-158 514-04 $\overline{10}$ = 3,2 - 4,0 mm 91-158 515-04 $\overline{10}$ = 4,8 - 40,0 mm	91-054 922-03 $\overline{10}$ = 2,2 - 4,0 mm $\overline{41}$ = 3,2 mm 91-054 926-03 $\overline{10}$ = 4,8 - 14,0 mm 91-054 927-03 $\overline{10}$ = 15,2 - 40,0 mm		
-6/01-900/56; /61	CN	91-158 815-04 $\overline{10}$ = 2,2 - 2,8 mm $\overline{41}$ = 3,2 mm 91-158 811-04 $\overline{10}$ = 3,2 - 24,0 mm	91-054 922-03 $\overline{10}$ = 2,2 - 4,0 mm $\overline{41}$ = 3,2 mm 91-054 926-03 $\overline{10}$ = 4,4 - 14,0 mm 91-054 927-03 $\overline{10}$ = 15,2 - 24,0 mm		
-6/03	BN	91-158 514-04 $\overline{10}$ = 4,0 mm 91-158 515-04 $\overline{10}$ = 4,8 - 40,0 mm	91-055 499-93 $\overline{10}$ = 4,0 - 11,2 mm 91-055 506-93 $\overline{10}$ = 12,0 - 22,0 mm 91-055 507-93 $\overline{10}$ = 24,0 - 40,0 mm		
-6/03-900/56; /61	BN	91-158 811-04 $\overline{10}$ = 4,0 - 24,0 mm	91-055 499-93 $\overline{10}$ = 4,0 - 11,2 mm 91-055 506-93 $\overline{10}$ = 12,0 - 22,0 mm 91-055 507-93 $\overline{10}$ = 24,0 mm		
-6/03	CN	91-158 514-04 $\overline{10}$ = 4,0 mm 91-158 515-04 $\overline{10}$ = 4,8 - 40,0 mm	91-055 499-93 $\overline{10}$ = 4,0 - 11,2 mm 91-055 506-93 $\overline{10}$ = 12,0 - 22,0 mm 91-055 507-93 $\overline{10}$ = 24,0 - 40,0 mm		
-6/03-900/56; /61	CN	91-158 811-04	91-055 499-93 $\overline{10}$ = 4,0 - 11,2 mm 91-055 506-93 $\overline{10}$ = 12,0 - 22,0 mm 91-055 507-93 $\overline{10}$ = 24,0 mm		
-19/01	BN	91-158 515-04	91-055 609-03	91-041 006-23	91-753 936-90
-19/01-900/56; /61	BN	91-158 811-04	91-055 609-03	91-041 006-23	91-753 936-90
-19/01	CN	91-158 515-04	91-055 609-03	91-041 006-23	91-753 936-90
-19/01-900/56; /61	CN	91-158 811-04	91-055 609-03	91-041 006-23	91-753 936-90

Equipement des sous-classes

Dotación de las subclases

Unterklasse Subclass Sous-classe Subclase	Ausführung Model Version Tipo de máquina	Nadelabstand in mm Needle gauge in mm Ecartement des aiguilles en mm Distancia entre agujas en mm	Nadelhalter [107] Needle holder Pince-aiguille Portaagujas	Stoffschieber [101] [102] Feed dog Griffe Transportador inferior
-57/01	BN	4,8-10,0	91-172 590-93 $\frac{10}{10}$ = 4,8-7,2 mm 91-172 840-93 $\frac{10}{10}$ = 8,0-10,0 mm	91-047 565-04
-57/01-900/56;/61	BN	4,8-10,0	91-172 590-93 $\frac{10}{10}$ = 4,8-7,2 mm 91-172 840-93 $\frac{10}{10}$ = 8,0-10,0 mm	91-059 313-04
-57/01	CN	4,8-10,0	91-710 004-93	91-047 565-04
-57/01-900/56;/61	CN	4,8-10,0	91-710 004-93	91-059 313-04
-58/01	BN	4,8-10,0	91-172 590-93 $\frac{10}{10}$ = 4,8-7,2 mm 91-172 840-93 $\frac{10}{10}$ = 8,0-10,0 mm	91-047 565-04
58/01-900/56;/61	BN	4,8-10,0	91-172 590-93 $\frac{10}{10}$ = 4,8-7,2 mm 91-172 840-93 $\frac{10}{10}$ = 8,0-10,0 mm	91-059 313-04
-58/01	CN	4,8-10,0	91-710 004-93	91-047 565-04
-58/01-900/56;/61	CN	4,8-10,0	91-710 004-93	91-059 313-04
-61/01	BN	2,4-20,0	91-176 068-93 $\frac{10}{10}$ = 2,4-4,0 mm 91-172 590-93 $\frac{10}{10}$ = 4,8-7,2 mm 91-172 840-93 $\frac{10}{10}$ = 8,0-14,0 mm 91-710 004-93 $\frac{10}{10}$ = 15,2-20,0 mm	91-047 563-04 $\frac{10}{10}$ = 2,4-4,0 mm 91-047 565-04 $\frac{10}{10}$ = 4,8-20,0 mm
-61/01-900/56;/61	BN	2,4-20,0	91-176 068-93 $\frac{10}{10}$ = 2,4-4,0 mm 91-172 590-93 $\frac{10}{10}$ = 4,8-7,2 mm 91-172 840-93 $\frac{10}{10}$ = 8,0-14,0 mm 91-710 004-93 $\frac{10}{10}$ = 15,2-20,0 mm	91-059 313-04
-61/01	CN	3,2-20,0	91-710 004-93	91-047 563-04 $\frac{10}{10}$ = 3,2-4,0 mm 91-047 565-04 $\frac{10}{10}$ = 4,8-20,0 mm
-61/01-900/56;/61	CN	3,2-20,0	91-710 004-93	91-059 313-04
-113/02	BN	2,4-13,2	91-176 068-93 $\frac{10}{10}$ = 2,4-4,0 mm 91-172 590-93 $\frac{10}{10}$ = 4,8-7,2 mm 91-172 840-93 $\frac{10}{10}$ = 8,0-13,2 mm	91-047 563-04 $\frac{10}{10}$ = 2,4-4,0 mm 91-047 565-04 $\frac{10}{10}$ = 4,8-13,2 mm

Equipement des sous-classes
Unterklassen-Ausstattung

Dotación de las subclases
Subclass organization

Unterklass Subclass Subclase	Ausführung Model Version Tipo de máquina	Stichplatte Needle plate Plaque à aiguille Placa de aguja	Nähfuß Presser foot Pied presseur Pie prensateelas	Apparat Attachment Appareil Aparato	Bandenträger Tape reel bracket Supporteur Portarrollos
-57/01	BN	91-158 515-04	91-054 926-03	91-040 317-93	
-57/01-900/56;/61	BN	91-158 811-04	91-054 926-03	91-040 317-93	
-57/01	CN	91-158 515-04	91-054 926-03	91-040 317-93	
-57/01-900/56;/61	CN	91-158 811-04	91-054 926-03	91-040 317-93	
-58/01	BN	91-158 515-04	91-054 926-03	91-040 316-93	
58/01-900/56;/61	BN	91-158 811-04	91-054 926-03	91-040 316-93	
-58/01	CN	91-158 515-04	91-054 926-03	91-040 316-93	
-58/01-900/56;/61	CN	91-158 811-04	91-054 926-03	91-040 316-93	
-61/01	BN	91-158 514-04 $\overline{10}$ = 2,4 - 4,0 mm 91-158 515-04 $\overline{10}$ = 4,8 - 20,0 mm	91-157 658-03 $\overline{10}$ = 2,4 - 14,0 mm 91-157 730-03 $\overline{10}$ = 15,2 - 20,0 mm		91-040 2
-61/01-900/56;/61	BN	91-158 811-04	91-157 658-03 $\overline{10}$ = 2,4 - 14,0 mm 91-157 658-03 $\overline{10}$ = 15,2 - 20,0 mm		91-040 2
61/01	CN	91-158 514-04 $\overline{10}$ = 3,2 - 4,0 mm 91-158 515-04 $\overline{10}$ = 4,8 - 20,0 mm	91-157 658-03 $\overline{10}$ = 3,2 - 14,0 mm 91-157 730-03 $\overline{10}$ = 15,2 - 20,0 mm		91-040 2
61/01-900/56;/61	CN	91-158 811-11-04	91-157 658-03 $\overline{10}$ = 3,2 - 14,0 mm 91-157 730-03 $\overline{10}$ = 15,2 - 20,0 mm		91-040 2
113/02	BN	91-158 514-04 $\overline{10}$ = 2,4 - 4,0 mm 91-158 515-04 $\overline{10}$ = 4,8 - 13,2 mm	91-155 640-03 $\overline{10}$ = 2,4; 2,8 mm $\overline{12}$ = 1,0; 1,5; 2,0 mm 91-155 640-03 $\overline{10}$ = 3,2; 3,6 mm $\overline{12}$ = 1,0 mm 91-057 323-03 $\overline{10}$ = 3,2; 3,6 mm $\overline{12}$ = 1,5 mm 91-057 890-03 $\overline{10}$ = 4,0; 13,2 mm $\overline{12}$ = 1,0; 1,5 mm 91-057 318-03 $\overline{10}$ = 3,2; 3,6 mm $\overline{12}$ = 2,0; 2,5; 3,0; 3,5 mm 91-057 892-03 $\overline{10}$ = 4,0 - 13,2 mm $\overline{12}$ = 2,0; 2,5; 3,0; 3,5 mm	$\overline{10}$ $\overline{12}$	

Unterklassen-Ausstattung

Subclass Organization

Unterklasse Subclass Sous-classe Subclase	Ausführung Model Version Tipo de máquina	Nadelabstand in mm Needle gauge in mm Écartement des aiguilles en mm Distancia entre agujas en mm	Nadelhalter (10/2) Needle holder Pince-aiguille Puntaagujas	Stoffschieber (41) (10/1) (10/2) Feed dog Griffe Transportador inferior
-113/02-900/56;/61	BN	2,4 - 13,2	91-176 068-93 $\overline{10}$ = 2,4 - 4,0 mm 91-172 590-93 $\overline{10}$ = 4,8 - 7,2 mm 91-172 840-93 $\overline{10}$ = 8,0 - 13,2 mm	91-059 313-04
-113/02	CN	3,2 - 13,2	91-710 004-93	91-047 563-04 $\overline{10}$ = 3,2 - 4,0 mm 91-047 565-04 $\overline{10}$ = 4,8 - 13,2 mm
-113/02-900/56;/61	CN	3,2 - 13,2	91-710 004-93	91-059 313-04

4 = Ausführung angeben
= indicate model
= Préciser la version
= Indique el tipo de máquina

10/2 = Nadelabstand bei Bestellung angeben
= State needle gauge on order
= Indiquer écartement des aiguilles à la commande
= Indique en los pedidos la distancia entre agujas

41 = Nadel diagonalabstand
= Diagonal needle distance
= Espacement diagonal des aiguilles
= Distancia diagonal entre agujas

10 = Nadelabstand
= Needle gauge
= Écartement des aiguilles
= Distancias entre agujas

12 = Absteppbreite
= Stitching margin
= Relarge de couture
= Margen de costura

60 = Wahlweise
= Optional
= Au choix
= Opcional

10/1 = je nach Nadelabstand ändert sich die Form
(z.B. beim Stoffschieber die Anzahl
der Zahnreihen)
= Certain design features change according
to the needle gauge (e.g. the number of tooth
rows on the feed dog)
= La forme est fonction de l'écartement
des aiguilles (par ex. le nombre des rangées
de dents de la griffe)
= La forma varia de acuerdo con la distancia entre agujas

12/2 = Absteppbreite bei Bestellung angeben
= Indicate stitching margin on order
= Indiquer le relarge de couture à la commande
= Indique el margen de costura en los pedidos

Equipement des sous-classes

Dotación de las subclases

Unterklassen-Ausstattung

Subclass organization

Subclass	Model	Version	Particularities	Particularities
Subclase	Modelo	Versión	Particularidades	Particularidades
3/02-900/56;/61	BN	91-158 811-04		91-155 640-03 $\overline{10}$ = 2,4; 2,8 mm $\overline{12}$ = 1,0; 1,5; 2,0 mm 91-155 640-03 $\overline{10}$ = 3,2; 3,6 mm $\overline{12}$ = 1,0 mm 91-057 323-03 $\overline{10}$ = 3,2; 3,6 mm $\overline{12}$ = 1,5 mm 91-057 890-03 $\overline{10}$ = 4,0 - 13,2 mm $\overline{12}$ = 1,0; 1,5 mm 91-057 318-03 $\overline{10}$ = 3,2; 3,6 mm $\overline{12}$ = 2,0; 2,5; 3,0; 3,5 mm 91-057 892-03 $\overline{10}$ = 4,0 - 13,2 mm $\overline{12}$ = 2,0; 2,5; 3,0; 3,5 mm
3/02	CN	91-158 514-04 $\overline{10}$ = 3,2 - 4,0 mm 91-158 515-04 $\overline{10}$ = 4,8 - 13,2 mm		91-155 640-03 $\overline{10}$ = 3,2; 3,6 mm $\overline{12}$ = 1,0 mm 91-057 323-03 $\overline{10}$ = 3,2; 3,6 mm $\overline{12}$ = 1,5 mm 91-057 318-03 $\overline{10}$ = 3,2; 3,6 mm $\overline{12}$ = 2,0; 2,5; 3,0; 3,5 mm 91-057 890-03 $\overline{10}$ = 4,0 - 13,2 mm $\overline{12}$ = 1,0; 1,5 mm 91-057 892-03 $\overline{10}$ = 4,0 - 13,2 mm $\overline{12}$ = 2,0; 2,5; 3,0; 3,5 mm
3/02-900/56;/61	CN	91-158 811-04		91-155 640-03 $\overline{10}$ = 3,2; 3,6 mm $\overline{12}$ = 1,0 mm 91-057 323-03 $\overline{10}$ = 3,2; 3,6 mm $\overline{12}$ = 1,5 mm 91-057 318-03 $\overline{10}$ = 3,2; 3,6 mm $\overline{12}$ = 2,0; 2,5; 3,0; 3,5 mm 91-057 890-03 $\overline{10}$ = 4,0 - 13,2 mm $\overline{12}$ = 1,0; 1,5 mm 91-057 892-03 $\overline{10}$ = 4,0 - 13,2 mm $\overline{12}$ = 2,0; 2,5; 3,0; 3,5 mm

Unterklassen-Übersicht/Table of subclasses/Table des sous-classes/Tabla de subclases

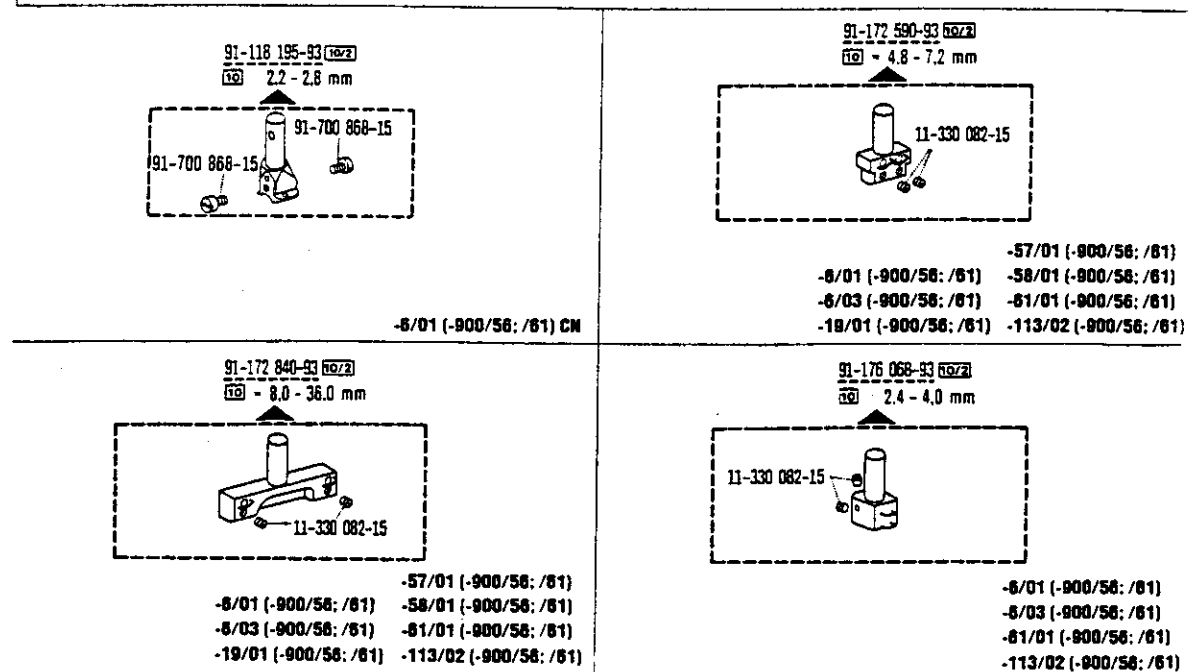

STRICKHAUSEN

91-176 343-93 ^{10/2}
¹⁰ = 1,2 - 2,8 mm

11-330 082-15

11-330 082-15

-6/01 (-900/56; /61)

91-710 004-93 ^{10/2}
¹⁰ = 4,0 - 40,0 mm

91-173 664-15

91-173 664-15

-57/01 (-900/56; /61)
 -6/01 (-900/56; /61) -58/01 (-900/56; /61)
 -6/03 (-900/56; /61) -61/01 (-900/56; /61)
 -19/01 (-900/56; /61) -113/02 (-900/56; /61)

91-710 234-93 ^{10/2}
¹⁰ = 36,0 - 40,0 mm

91-173 664-15

91-173 664-15

-6/01
 -6/03

91-047 563-04 ⁴ ^{10/2}
¹⁰ = 1,2 - 2,0 mm ¹⁰ = 2,4 - 4,0 mm
⁴¹ = 3,2 mm

-6/01
 -6/03
 -61/01
 -113/02

91-047 565-04 ⁴ ^{10/1} ^{10/2}
¹⁰ = 4,8 - 40,0 mm

-6/01
 -6/03
 -19/01
 -57/01
 -58/01
 -61/01
 -113/02

91-059 312-04 ⁴ ^{10/2}
¹⁰ = 1,2 - 2,8 mm
⁴¹ = 3,2 mm

-6/01-900/56; /61

91-059 313-04 ⁴ ^{10/1} ^{10/2}
¹⁰ = 3,2 - 4,4 mm ¹⁰ = 4,8 - 24,0 mm

-6/01 (-900/56; /61)
 -6/03 (-900/56; /61)
 -19/01 (-900/56; /61)
 -57/01 (-900/56; /61)
 -58/01 (-900/56; /61)
 -61/01 (-900/56; /61)
 -113/02 (-900/56; /61)

91-158 514-04 ⁴ ^{10/2}
¹⁰ = 1,2 - 4,0 mm

-6/01
 -6/03
 -61/01
 -113/02

91-158 515-04 ⁴ ^{10/1} ^{10/2}
¹⁰ = 4,8 - 40,0 mm

-6/01
 -6/03
 -19/01
 -57/01
 -58/01
 -61/01
 -113/02

91-158 811-04 ⁴ ^{10/1} ^{10/2}
¹⁰ = 2,4 - 8,0 mm

-6/01-900/56; /61
 -6/03-900/56; /61
 -19/01-900/56; /61
 -57/01-900/56; /61
 -58/01-900/56; /61
 -61/01-900/56; /61
 -113/02-900/56; /61

91-158 815-04 ⁴ ^{10/2}
¹⁰ = 1,2 - 2,8 mm

-6/01-900/56; /61

91-054 922-03 ⁴ ^{10/2}

-6/01 (-900/56; /61)

91-054 926-03 ⁴ ^{10/2}

-6/01 (-900/56; /61)
 -57/01 (-900/56; /61)
 -58/01 (-900/56; /61)

91-054 927-03 ⁴ ^{10/2}

-6/01 (-900/56; /61)

91-055 499-93 ⁴ ^{10/2}

-6/03 (-900/56; /61)

Unterklassen-Ubersicht/ Table of subclasses/ Table des sous-classes/ Tabla de subclases

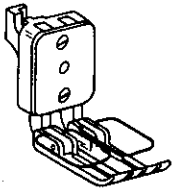
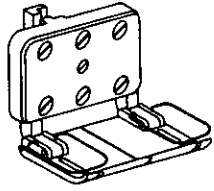
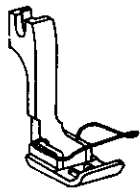
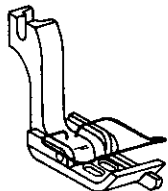
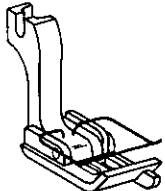
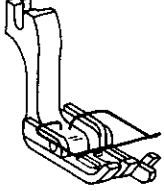
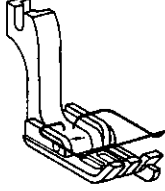
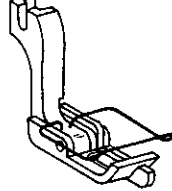
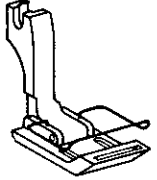
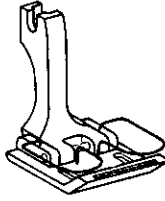
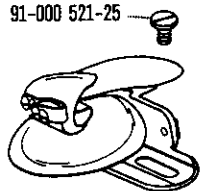
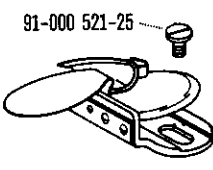
<p>91-055 506-93 [4] [10/2]</p>  <p>-6/03 (-900/56; /61)</p>	<p>91-055 507-93 [4] [10/2]</p>  <p>-6/03 (-900/56; /61)</p>	<p>91-055 609-03 [4] [60/2]</p>  <p>-19/01 (-900/56; /61)</p>	<p>91-057 318-03 [4] [10/2] [12/2]</p>  <p>-113/02 (-900/56; /61)</p>
<p>91-057 323-03 [4] [10/2] [12/2]</p>  <p>-113/02 (-900/56; /61)</p>	<p>91-057 890-03 [4] [10/2] [12/2]</p>  <p>-113/02 (-900/56; /61)</p>	<p>91-057 892-03 [4] [10/2] [12/2]</p>  <p>-113/02 (-900/56; /61)</p>	<p>91-155 640-03 [4] [10/2] [12/2]</p>  <p>-113/02 (-900/56; /61)</p>
<p>91-157 658-03 [4] [10/2]</p>  <p>-61/01 (-900/56; /61)</p>		<p>91-157 730-03 [4] [10/2]</p>  <p>-61/01 (-900/56; /61)</p>	
<p>91-040 316-93 [5] [10/2]</p> <p>91-000 521-25</p>  <p>-58/01 (-900/56; /61)</p>		<p>91-040 317-93 [5] [10/2]</p> <p>91-000 521-25</p>  <p>-57/01 (-900/56; /61)</p>	

91-041 006-23 [5]

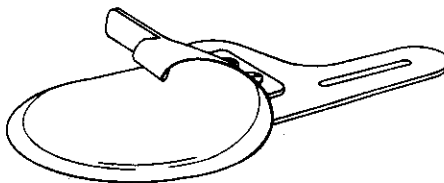

Unterklassen-Übersicht/Table of subclasses/Table des sous-classes/Tabla de subclasses

91-753 936-90

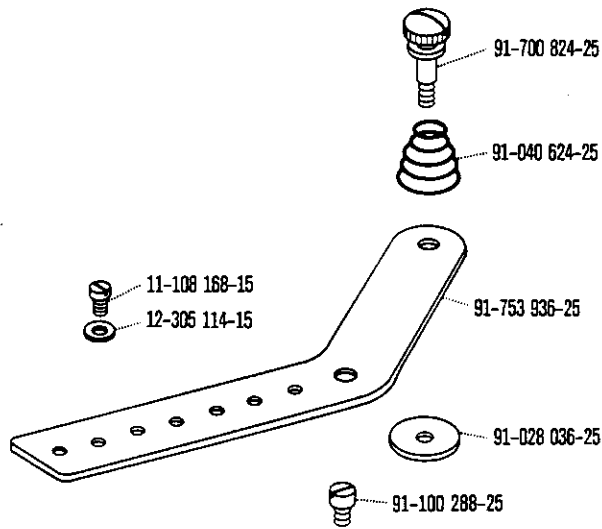

-19/01 (-900/56; /61)

91-040 207-91

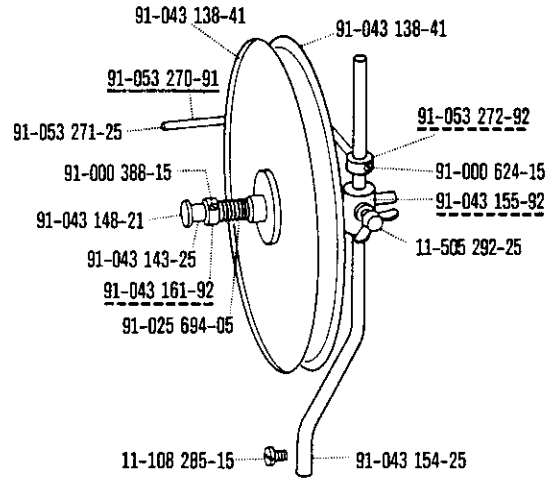

-61/01 (-900/56; /61)