

Eastman®

THE EASTMAN®
Air Brush Marking System

68-26083 (Triple Tool Head)

68-26083-1 (H.D. Tool Head)

68-26083-2 (Triple Tool Head) Dual External Mount

68-26083-3 (Fiber Tool Head) Dual External Mount

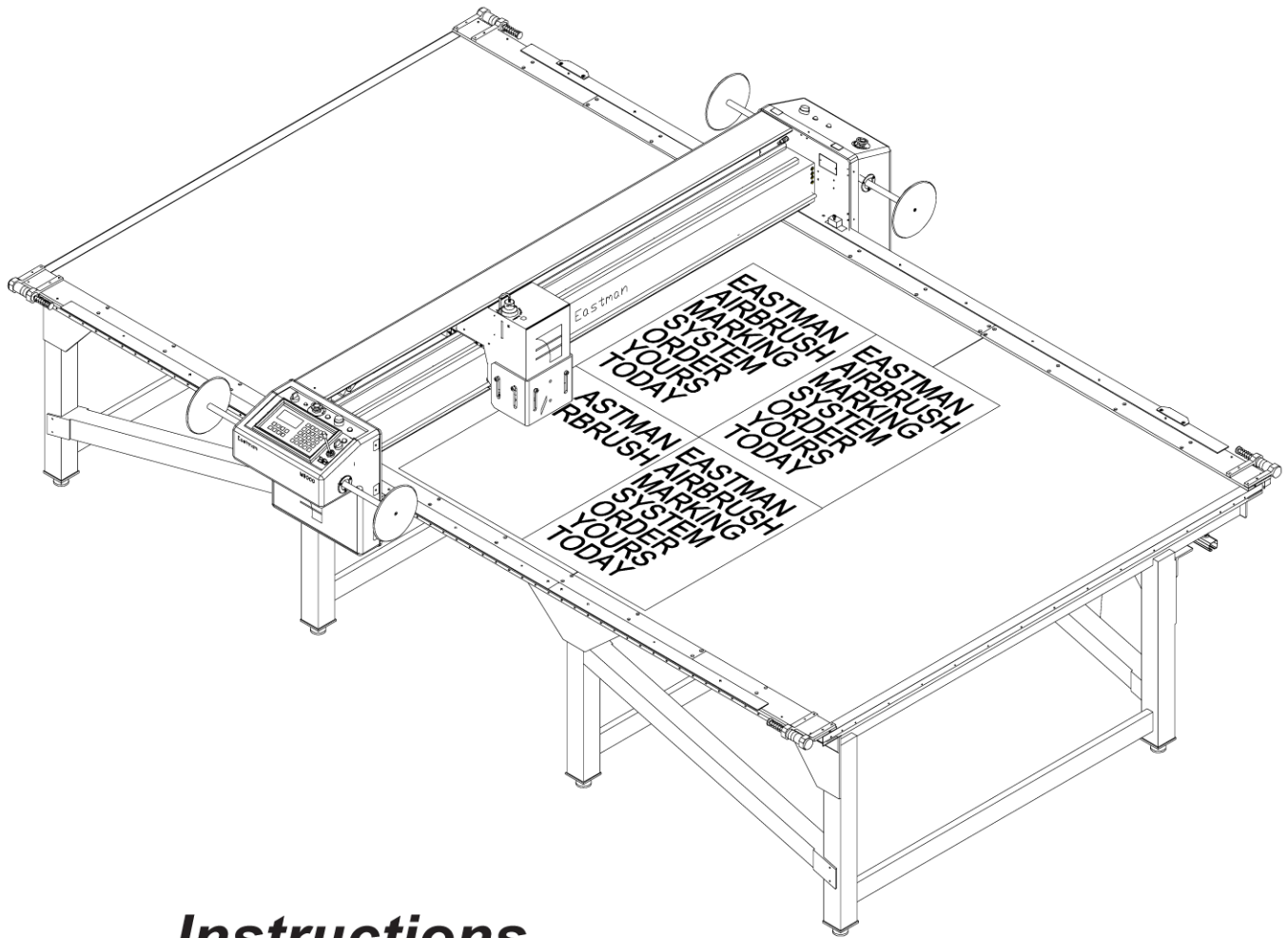

Instructions
and
Illustrated Parts List

Eastman®

Over a Century of Cutting Expertise

The Air Brush Marking System is designed to easily mark parts during the cutting process to eliminate the time consuming step of marking parts before or after cutting. The marking of parts can be used for parts identification, sewing lines, mating parts, company logo's, instructions, etc. Marking inks are available in a wide variety of colors as permanent and washable inks. If the color you require is not shown, please consult factory.

IMPORTANT

The purchaser must instruct all operators on the proper use of the equipment. All standard industrial safety measures and equipment should be provided to protect the operator. Operators must be cautioned that improper or careless use of this equipment may cause personal injury. If you do not have qualified operators to instruct new persons, contact your Eastman sales representative or Eastman factory direct.

Disconnect electrical power source before proceeding with any installation, adjustment or repair of the Eastman Automated Cutting System.

Installation

The Air brush Marking System is design for quick and easy installation with optimal performance. Before you begin installation, please read the instructions carefully. Familiarize yourself with all the components required.

- 1) Disconnect the main power and relieve air pressure to the gantry.
- 2) Remove the gantry e-chain cover and the tool head cover.
- 3) Remove and disassembly the solenoid block assembly as shown on page 5. Install the additional solenoid (#36) with fittings. Mount the complete assembly using the adapter bar. Connect solenoid electrical connector to the mating connector on the y-axis board (SOL4).
- 4) Remove the existing laser pointer mount and replace with the new air brush mounting base as shown on page 5.
- 5) Mount the new air brush stylus using the locking band.
- 6) Install air line and ink line as shown.
- 7) Remove the tool guard from the old toll head cover and install on the new tool head cover.
- 8) Install new tool head cover. The ink reservoir will slip in under the tool head cover and into the holder.
- 9) Your air brush marking system is now ready for operation.

Operation

 **WARNING:** Spray materials may be harmful if inhaled or allowed to come into contact with the skin or eyes. Consult the product label and Material Safety Data Sheet supplied with the spray material. Follow all safety precautions. Use in Well Ventilated Area to remove fumes, dust or over spray.

Maximum Air Pressure 100 P.S.I.

Initial Setup

Set the tool head mount setting to STD 4 Tool.

REF: Log in to easicut to gain access to machine settings. (User Name: Eastman Password: Eastman*tech). Select: Options. Select: Machine... . Select: System. Select Tool Head Type: STD 4 TOOL. Select: OK.

Set the Tool Mount 4 to down bit 8 (Mount 4 is the air brush mount).

REF: Log in to easicut to gain access to machine settings. (User Name: Eastman Password: Eastman*tech). Select: Options. Select: Machine... . Select: Tool Mounts. Select Tool Mount: Mount 4. Enter 8 for Down Bit setting. Select: OK.

If required, set the offsets and time settings now.

Set the Air Brush tool pressure setting to 70.

REF: Select: Options. Select: Machine... . Select: Tools. Select Tool: Airbrush. Select Tool Mount: Mount 4. Select Tool Type: Draw Tool. Enter 7 for Velocity and 70 for pressure. Select: OK.

Machine Operation

The Air Brush Marking System is designed to operate in the same manner as any other tool on the tool head. Create a file with the cut pattern and marking pattern on separate layers. Set the marking layer tool mount by drag & drop to the airbrush tool mount picture. This will set the tool mount for the marking layer. Remove the air sealing pin from the ink bottle top, this will help ink flow. The machine is ready for normal operation.

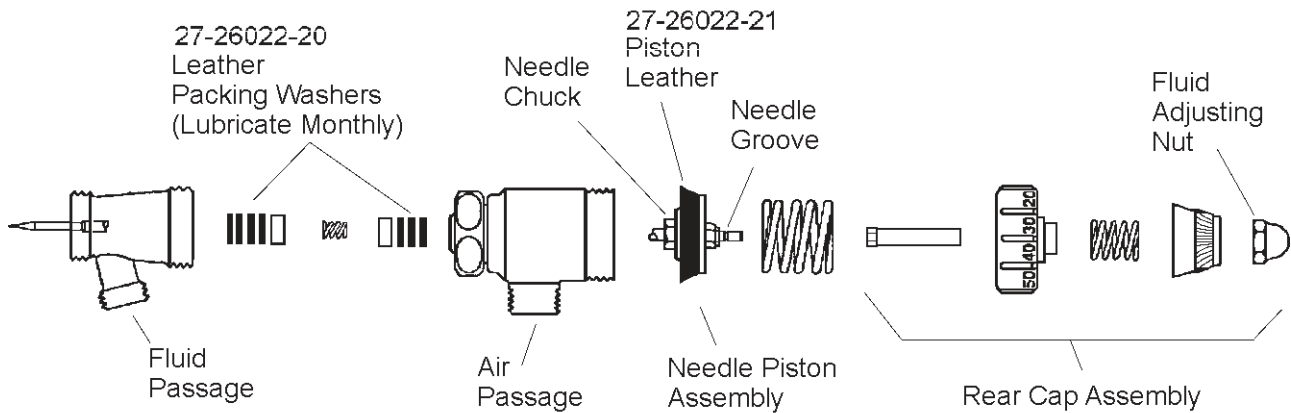

Manual Operation

⚠ Caution: This will engage the air brush stylus allowing ink to flow. Marking of material and cut surface may occur. Protect surfaces as required.

The Air Brush Tool can be turned ON & OFF for setup and testing purposes. To Turn the air brush tool on using the UIT Panel, press Option, press A, press B, and press Enter to begin spraying. The tool enable On/Off switch can be used to turn the tool on and off.

To turn off this feature, press Option, press A, press B, and press Enter.

Note: This feature uses the tool settings from the machine options menu. Not the layer settings.

Adjustments

Marking line width and density will vary depending on the material. Testing will yield the best results for the following settings.

Fluid Flow

Located on the air brush stylus, turn the Fluid Adjusting Knob counterclockwise to increase fluid flow and clockwise to decrease fluid flow.

Stylist Height (1/4" minimum gap)

To adjust the stylus height loosen the air brush mount screw and adjust as required.

Velocity (3-7)

Velocity is the speed of the tool when marking. This is set on the marking layer. Select the velocity number on the layer and type in the desired number.

Air Pressure (60-70 PSI)

Note: The minimum operating pressure of the air stylus is 60 PSI @ 5 scfm during marking. This must be verified using pressure gauge tool #27-26024

The air pressure is set on the marking layer. Select the air pressure number on the layer and type in the desired pressure.

Maintenance

The Air Brush Stylus has been design for minimum maintenance. The leather packing washers should be lubricated once a month with light oil. Old packing washers cause leakage of air or fluid.

Ink Refill

The Ink Reservoir (1/2 Pint Ink Bottle) should not be refilled. When the ink supply runs low, replace the 1/2 pint ink bottle with a fresh bottle of ink. This will eliminate impurities clogging the air brush stylus.

Bleeding Air from the Ink Line

With the air brush system installed, place a piece of nonporous material under the air brush. Remove the air sealing pin from the ink bottle top. Turn the Tool Enable switch to Off position (Located on the gantry). Press Option, press A, press B, and press Enter to enable air pressure. Turn the Fluid Adjusting Knob counterclockwise to increase fluid flow and clockwise to decrease fluid flow.

Spray Tip and Cap replacement.

1. Remove Air Brush Stylus from tool head.
2. Release needle pressure from the seat of tip, by backing off the fluid adjusting nut.
3. Loosen spray cap nut and remove spray cap and spray tip. **Leave Needle in place.**
4. Check cap and tip size. Install new cap and tip. Note: Use only matching size cap and tip.
5. Secure Spray Cap nut.



Cap Alignment

(Continued on page 11)

Eastman®

Over a Century of Cutting Expertise

Air Brush Marking Assembly

68-26083 (Triple Tool Head Only)

68-26083-1 (Heavy Duty Tool Head Only)

ITEM	PART No.	DESCRIPTION	QTY
1	546-4-8	1/8" Pop Rivet	2
*2	333-102-8S	Screw, Button Hd. #10-32 x 1/2	4
*3	409-99	Finish Washer, #10	4
4	91-26021	Air Brush Decal	1
5	67-26187-2	Cover, Triple with Air Brush	1
	67-26072-1	Cover, Triple w/Air Brush (108")	1
6	67-26327	Bracket, Bottle Holder	1
7	AEC-20-G	Holding Spring	1
*8	54-26393	Shoulder Bolt	6
*9	67-26182	Tool Guard	1
*10	See Chart	1/2 Pint Ink	1
*11	NOT USED	NOT USED	1
12	70-26025	Fluid Adjustment Tool	1
13	70-26027	Tool Handle	1
14	70-26028	14" Adapter	1
15	70-26029	3/8" Socket	1
16	68-26084	Ink Reservoir, 1/2 Pint	1
17	27-02996-3	Ink Tubing	3
18	67-26348	Hose Clamp	1
19	67-26349	Sealing Pin	1
20	54-26453	Bottle Top, Ink	1
21	65-26023	Bottle Top Seal	1
22	242C1 U	Ink Bottle	1
*23	91-26020	Decal, Ink Bottle	1
24	333-93-8	Screw, Button Hd. #8-32 x 1/2	2
25	335-93-10	Screw, Socket Hd. #8-32 x 5/8	1
26	67-26323	Mounting Base	1
27	67-26322	Air Brush Mount	1
28	211-93	Stop Nut, #8-32	1
29	27-26021	Air Brush Stylus with Fittings	1
30	670-224	Locking Band	1
31	27-26020	1/4" Tube Connector	2
32	27-26023	Shut-off Clamp	1
33	410-010	Washer, Flat, #10	2
34	335-102-20	Screw, Socket Hd. #10-32 x 1 1/4	1
35	335-102-10	Screw, Socket Hd. #10-32 x 5/8	1
36	27-H0382-2	Solenoid, Single Station	1
37	100-13-7	Swivel Elbow, 1/4" Tube	1
38	27-H0409	1/8"npt Plug	1
39	335-102-10	Screw, Socket Hd. #10-32 x 5/8	1
40	54-26452	Adapter Bar, 6 Station	1
41	27-02996-1	1/4" OD. Air Line	3

ITEM	PART No.	DESCRIPTION	QTY
42	67-26147-1	HD. Tool Head Cover	1
43	67-26323-1	HD Style Mounting Base	1
44	54-26452-1	Adapter Bar, 4 Station	1

* Not Included in Assembly

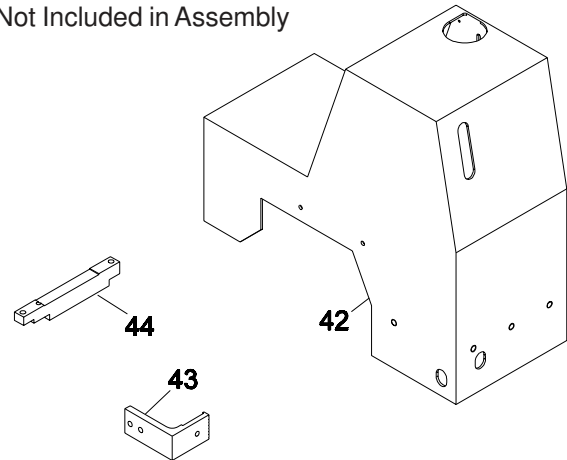

Optional Air Brush Components

ITEM	PART No.	DESCRIPTION	QTY
45	27-26022-1	Spray Needle	A/R
46	27-26022-12	Spray Tip, Size #3 (.046")	A/R
	27-26022-10	Spray Tip, Size #2 (.040")	A/R
	27-26022-2	Spray Tip, Size #1 (.028")	A/R
	27-26022-4	Spray Tip, Size #0 (.021")	A/R
	27-26022-6	Spray Tip, Size #00 (.018")	A/R
	27-26022-8	Spray Tip, Size #000 (.014")	A/R
47	27-26022-13	Spray Cap, Size #3 (.046")	A/R
	27-26022-11	Spray Cap, Size #2 (.040")	A/R
	27-26022-3	Spray Cap, Size #1 (.028")	A/R
	27-26022-5	Spray Cap, Size #0 (.021")	A/R
	27-26022-7	Spray Cap, Size #00 (.018")	A/R
	27-26022-9	Spray Cap, Size #000 (.014")	A/R

48 67-26588 Filter, Ink A/R

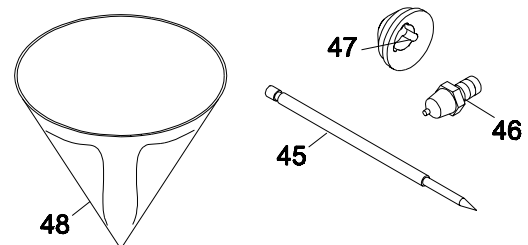

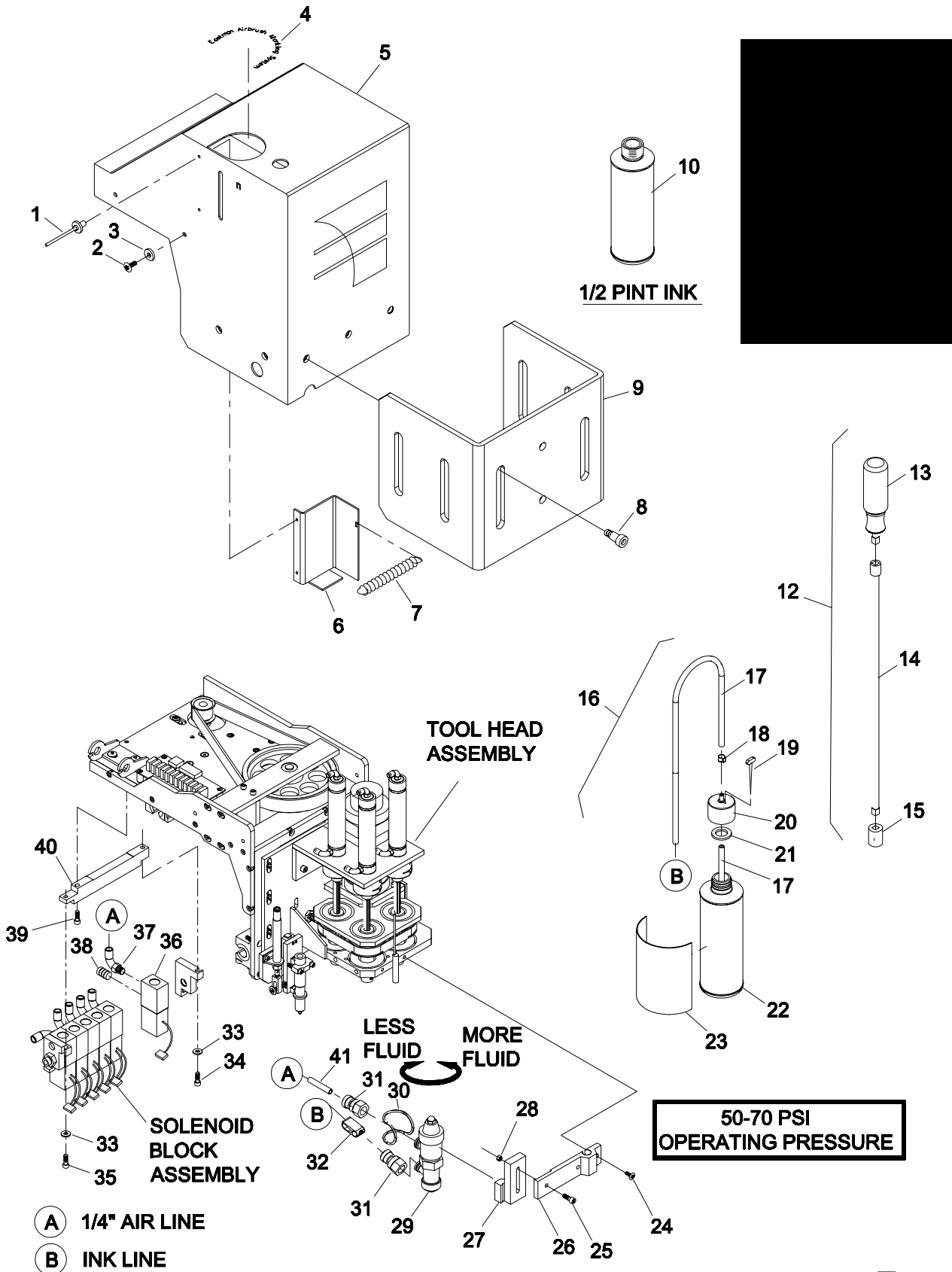

Dual Air Brush Marking Assembly

68-26083-2 External Mount (Triple Tool Head Only)

ITEM	PART No.	DESCRIPTION	QTY
1	91-26021	Air Brush Decal	1
2	67-26187-3	Cover, Triple with Dual Air Brush	1
*3	333-102-8S	Screw, Button Hd. #10-32 x 1/2	4
*4	409-99	Finish Washer, #10	4
5	67-26182-1	Tool Guard, Triple w/Dual Ext.	1
*6	54-26393	Shoulder Bolt	6
7	See Chart	1/2 Pint Ink	1
8	70-26027	Tool Handle	1
9	70-26028	14" Adapter	1
10	70-26029	3/8" Socket	1
11	70-26025	Fluid Adjustment Tool	1
12	68-26084	Ink Reservoir, 1/2 Pint	2
13	27-02996-3	Ink Tubing	5
14	67-26348	Hose Clamp	2
15	67-26349	Sealing Pin	2
16	54-26453	Bottle Top, Ink	2
17	65-26023	Bottle Top Seal	2
18	242C1 U	Ink Bottle	2
*19	91-26020	Decal, Ink Bottle	1
20	211C1-2	Foam Tape	1
21	67-26351	External Bottle Mount	2
22	333-93-8S	Screw, Button Hd. #8-32 x 1/2	8
23	67-26355	Dual Airbrush Mount, Triple, Ext.	1
24	335-93-10	Screw, Socket Hd. #8-32 x 5/8	2
25	404-080	Lock Washer, #8 External	2
*26	81-00002	Laser Pointer	1
27	342-86-4	Setscrew, #6-32 x 1/4	1
28	335-93-8	Screw, Socket Hd. #8-32 x 1/2	1
29	335-93-10	Screw, Socket Hd. #8-32 x 5/8	2
30	67-26322	Air Brush Mount	2
31	211-93	Stop Nut, #8-32	2
32	27-26021	Air Brush Stylus with Fittings	2
33	27-26020	1/4" Tube Connector	4
34	27-02996-1	1/4" OD. Air Line	6
35	670-224	Locking Band	2
36	410-010	Washer, Flat, #10	2
37	335-102-20	Screw, Socket Hd. #10-32 x 1 1/4	1
38	335-102-10	Screw, Socket Hd. #10-32 x 5/8	1
39	27-H0382-2	Solenoid, Single Station	1
40	100-13-7	Swivel Elbow, 1/4" Tube	1
41	27-H0409	1/8"npt Plug	1
42	335-102-10	Screw, Socket Hd. #10-32 x 5/8	1
43	54-26452	Adapter Bar, 6 Station	1
44	100-14-7	Y-Port Fitting, 1/4" Push-on	1

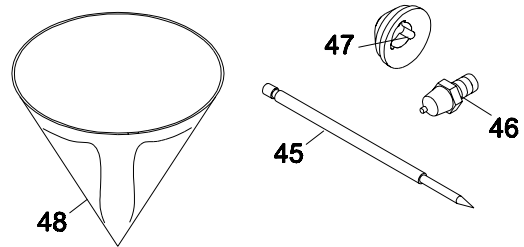

Optional Air Brush Components			
ITEM	PART No.	DESCRIPTION	QTY
45	27-26022-1	Spray Needle	A/R
46	27-26022-12	Spray Tip, Size #3 (.046")	A/R
	27-26022-10	Spray Tip, Size #2 (.040")	A/R
	27-26022-2	Spray Tip, Size #1 (.028")	A/R
	27-26022-4	Spray Tip, Size #0 (.021")	A/R
	27-26022-6	Spray Tip, Size #00 (.018")	A/R
	27-26022-8	Spray Tip, Size #000 (.014")	A/R
47	27-26022-13	Spray Cap, Size #3 (.046")	A/R
	27-26022-11	Spray Cap, Size #2 (.040")	A/R
	27-26022-3	Spray Cap, Size #1 (.028")	A/R
	27-26022-5	Spray Cap, Size #0 (.021")	A/R
	27-26022-7	Spray Cap, Size #00 (.018")	A/R
	27-26022-9	Spray Cap, Size #000 (.014")	A/R

48 67-26588 Filter, Ink A/R

* Not Included in Assembly

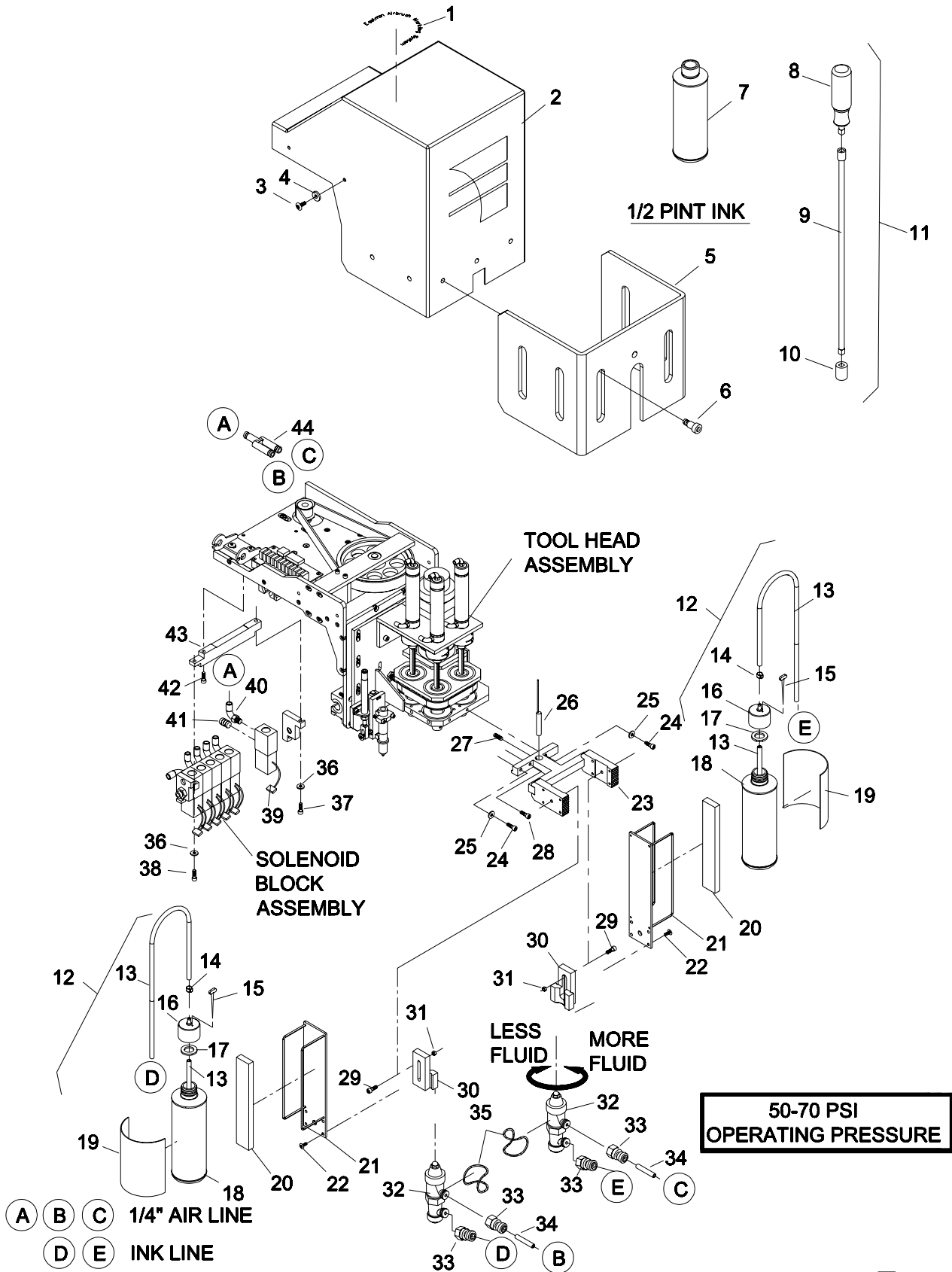

Dual Air Brush Marking Assembly

68-26083-3 External Mount (Fiber Tool Head Only)

ITEM	PART No.	DESCRIPTION	QTY
1	91-26021	Air Brush Decal	1
*2	67-26126	Cover, Fiber Head	1
*3	333-102-8S	Screw, Button Hd. #10-32 x 1/2	4
*4	409-99	Finish Washer, #10	4
5	67-26148-2	Tool Guard	1
*6	54-26393	Shoulder Bolt	4
*7	See Chart	1/2 Pint Ink	1
8	70-26027	Tool Handle	1
9	70-26028	14" Adapter	1
10	70-26029	3/8" Socket	1
11	70-26025	Fluid Adjustment Tool	1
12	68-26084	Ink Reservoir, 1/2 Pint	2
13	27-02996-3	Ink Tubing	5
14	67-26348	Hose Clamp	2
15	67-26349	Sealing Pin	2
16	54-26453	Bottle Top, Ink	2
17	65-26023	Bottle Top Seal	2
18	242C1 U	Ink Bottle	2
*19	91-26020	Decal, Ink Bottle	1
20	211C1-2	Foam Tape	1
21	67-26351	External Bottle Mount	2
22	333-93-8S	Screw, Button Hd. #8-32 x 1/2	8
23	335-102-12	Screw, Socket Hd. #10-32 x 3/4	4
24	335-93-10	Screw, Socket Hd. #8-32 x 5/8	2
25	67-26323-3	Right Mount, Ext., Fiber Hd.	1
26	67-26323-4	Left Mount, Ext., Fiber Hd.	1
27	67-26322-1	Air Brush Mount, Extended	2
28	211-93	Stop Nut, #8-32	2
29	27-26021	Air Brush Stylus with Fittings	2
30	27-26020	1/4" Tube Connector	4
31	27-02996-1	1/4" OD. Air Line	6
32	670-224	Locking Band	2
*33	410-010	Washer, Flat, #10	2
*34	335-102-20	Screw, Socket Hd. #10-32 x 1 1/4	2
35	27-H0382-2	Solenoid, Single Station	2
36	27-H0409	1/8"npt Plug	2

* Not Included in Assembly

Optional Air Brush Components			
ITEM	PART No.	DESCRIPTION	QTY
45	27-26022-1	Spray Needle	A/R
46	27-26022-12	Spray Tip, Size #3 (.046")	A/R
	27-26022-10	Spray Tip, Size #2 (.040")	A/R
	27-26022-2	Spray Tip, Size #1 (.028")	A/R
	27-26022-4	Spray Tip, Size #0 (.021")	A/R
	27-26022-6	Spray Tip, Size #00 (.018")	A/R
	27-26022-8	Spray Tip, Size #000 (.014")	A/R
47	27-26022-13	Spray Cap, Size #3 (.046")	A/R
	27-26022-11	Spray Cap, Size #2 (.040")	A/R
	27-26022-3	Spray Cap, Size #1 (.028")	A/R
	27-26022-5	Spray Cap, Size #0 (.021")	A/R
	27-26022-7	Spray Cap, Size #00 (.018")	A/R
	27-26022-9	Spray Cap, Size #000 (.014")	A/R

48 67-26588 Filter, Ink A/R

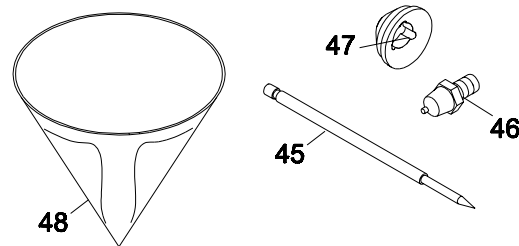

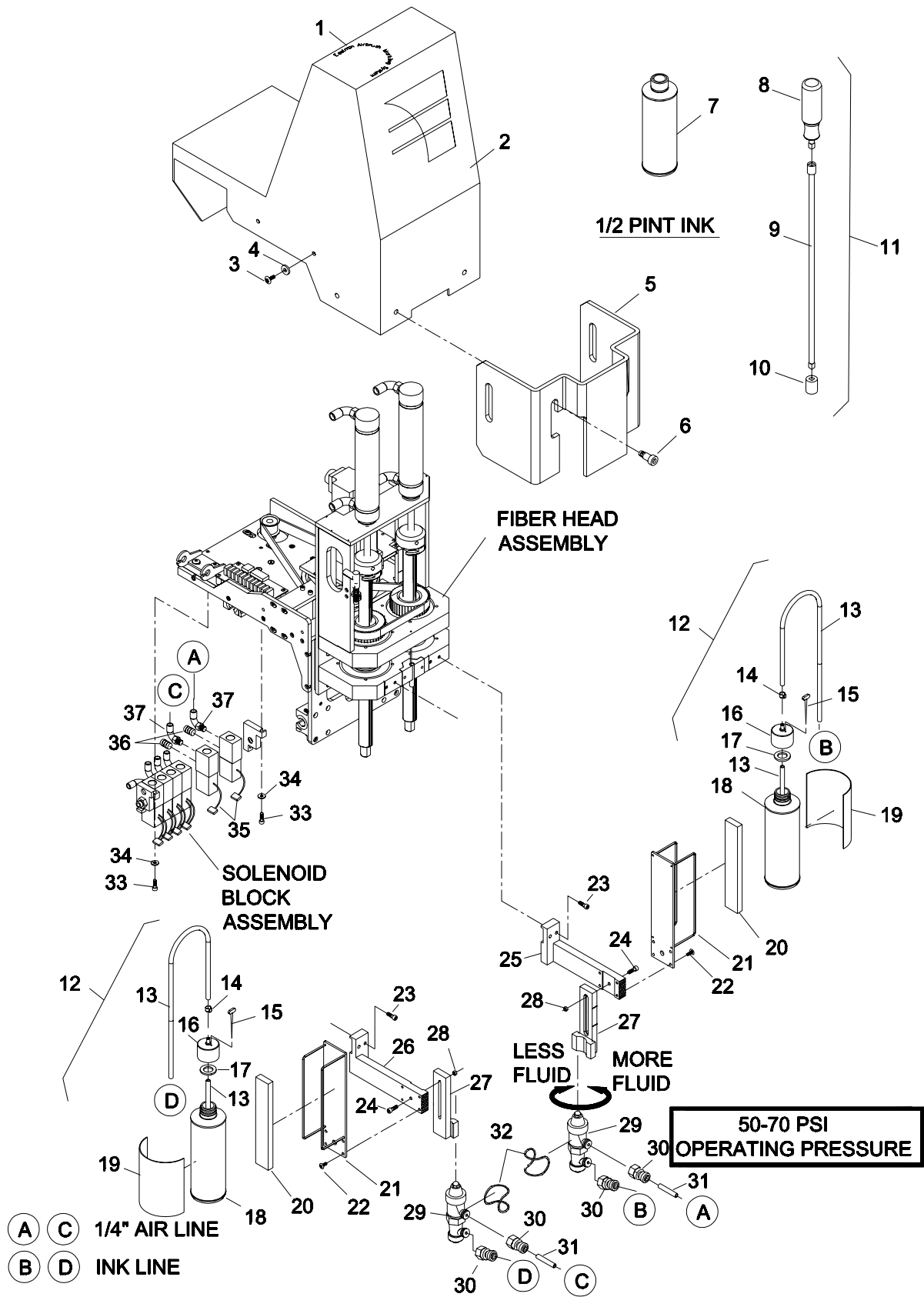

Optional Components

GRAVITY FEED RESERVOIR (1/2 Pint) 68-26084-1

ITEM	PART No.	DESCRIPTION	QTY
1	67-26349	Sealing Pin	1
2	54-26453-3	Bottle Top, Ink, Gravity Feed	1
3	65-26023	Bottle Top Seal	1
4	100-17-7	Bottle Fitting, Gravity Feed	1
5	54-26484	Ink Bottle, Gravity Feed	1
6	67-26348	Hose Clamp	1
7	27-02996-3	Ink Tubing	1

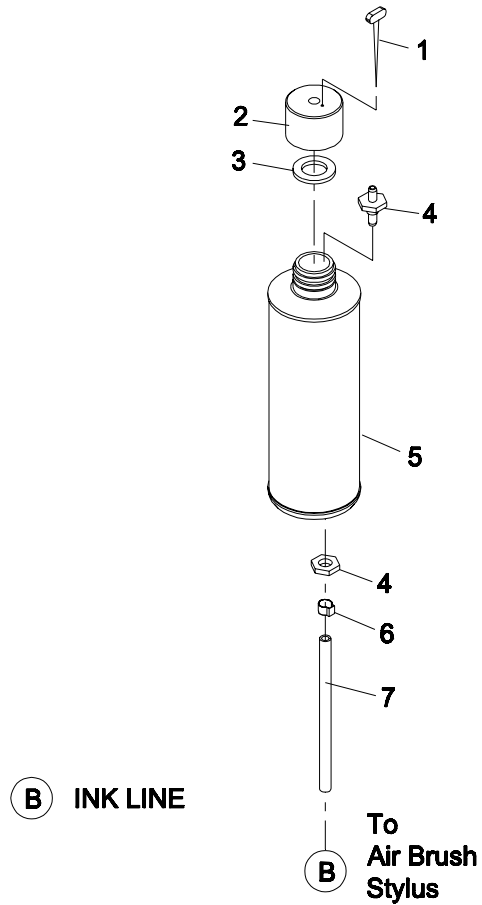

AIR GAUGE TOOL 27-26024

ITEM	PART No.	DESCRIPTION	QTY
1	100-18-29	Pressure Gauge, 0-100 PSI	1
2	100-14-10	Tee Fitting, 1/8"npt, 1/4" Tube	1
3	27-02996-1	1/4" OD. Air Line	1

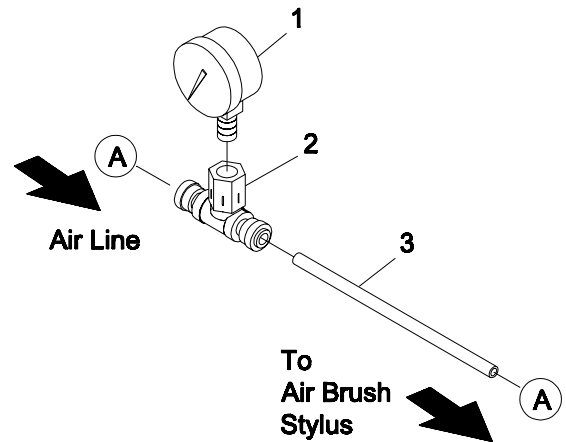

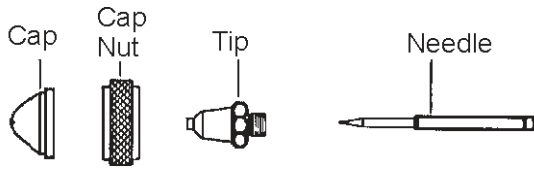

Needle Removal

1. Remove Air Brush Stylus from tool head.
2. Release needle pressure from the seat of tip, by backing off the fluid adjusting nut.
3. Remove the Rear Cap Assembly.
4. Using a pair of pliers, grip the Needle Piston Assembly nut and pull the assembly out.
5. Loosen the needle chuck and slide needle out.
6. Replace needle to desired position and secure needle chuck.
7. Reassemble in reverse order.

Needle Setting

Ink should be mixed thoroughly and always strained through a lint free cloth or fine mesh strainer before using. The Needle-Piston Assembly has a needle chuck which locks the needle in position. The single groove on the shank of the needle indicates location at which to lock the piston. Lock piston slightly below mark for use with very heavy fluids and slightly above mark (nearer blunt end) for light fluids. Example: Eastman MP style ink requires the groove to be completely covered.

Cleaning

Flush clean solvent through the fluid passage of the stylist and wipe off the outside with clean solvent. Never leave the entire stylist immersed in solvent. Dirty spray caps and tips should be cleaned by soaking in solvent and blown clean with air.

Note: Never use wire or sharp instruments to clean ports as permanent damage may occur.

Helpful Hints

- Always keep material under airbrush stylus when marking. This will help keep your table surface clean and free from ink.
- Begin each day by marking a short pattern on scrap material. This will clean the stylus and bring ink to the stylus for future use.
- End each day by marking a short pattern on scrap material. This will clean the stylus.
- Shake ink well before use. This will allow the color pigment to mix and give a even color when marking.

- Stylus should never be closer than 1/4" from material. This will obstruct airflow causing ink to build up on the cap. Wipe cap clean.
- The Vent hole in the ink reservoir should be closed with the sealing pin when not in use. If the vent hole is not sealed, the ink will thicken and may cause airbrush clogging.
- If refilling the in reservoir from gallon containers, the ink reservoir should be drained and cleaned out periodically. (dependent ink usage). This will help avoid thick sediment from forming at the bottom of the ink reservoir. Always use paint filter #67-26588 when filling paint reservoir.

Trouble Shooting

Problem	Solution
No ink flow	a. Increase fluid flow b. Dirty cap, wipe stylus cap clean c. No ink, replace ink and bottle d. Breather hole plugged in cap e. Verify operating air pressure f. Vacuum leak, check fittings
Little fluid flow	a. Increase fluid flow b. Decrease velocity c. Breather hole plugged in cap
Excess fluid	a. Decrease fluid flow b. Worn packing washers c. Incorrect needle groove setting
Fluid Leak	a. Check ink line fittings b. Ink line connected to wrong fitting
Inconsistent pattern	a. Wipe clean stylus cap b. Clean stylus c. Breather hole plugged in cap
Fuzzy lines	a. Increase fluid flow b. Slow velocity c. Lower stylus height
Wet pattern	a. Decrease fluid flow b. Increase velocity c. Incorrect needle groove setting
AB Function not working	a. Set Pointer tool type to No_Tool

Eastman®

Over a Century of Cutting Expertise

Marking Ink Selection Chart

Permanent Marking Ink (Medium Pigment)

Part Number	Color	1/2 Pint	... Quart
67-26326-01MP	Black	X X
67-26326-02MP	Red	X X
67-26326-03MP	Blue	X X
67-26326-04MP	Silver	X X
67-26326-31MP	Green	X X
67-26326-51MP	White	X X
67-26326-59MP	Yellow	X X
67-26326-72MP	Gold	X X



1/2 Pint



1 QUART

Permanent Marking Ink (Heavy Pigment)

Part Number	Color	1/2 Pint	... Quart
67-26326-01HP	Black	X X
67-26326-51HP	White	X X

UV Fluorescent Ink

Part Number	Color	1/2 Pint	... Quart
67-26326-UVMP	UV	X X

Washable Marking Ink

Part Number	Color	1/2 Pint	... Quart
67-26326-01WP	Black	X X
67-26326-51WP	White	X X
67-26326-59WP	Yellow	X X

Ink Sample Kit

Part Number	Color	1/2 Pint	... Quart
96-26075-MPYBW	Y/B/W	- X
96-26075-WPYBW	Y/Y/B/W	- X
96-26075-MPYBW	Y/Y/B/W	- X

Note: To order Quart Size container add Q after the part number.
 Medium, Heavy and UV pigment inks carry a 1 1/2 year shelf life.
 Washable inks carry a 6 month shelf life.
 Consult factor for: MSDS spec. sheets and additional colors.
 Always Use Eastman Medium Mesh Paint Filter #67-26588.

Limited Warranty. Eastman warrants to the buyer that the equipment shall be free from defects in materials or workmanship for a period of 180 days commencing on the date of invoice. Any goods or parts claimed by the buyer to be defective must be returned to Eastman, freight charges prepaid, within the 180-day warranty period. If Eastman determines that the goods or parts are defective in materials or workmanship, Eastman's sole obligation under this warranty shall be, at Eastman's sole option, to repair or replace the defective goods or parts or to provide the buyer a credit equal to the portion of the purchase price allocable to the defective goods or parts. This warranty shall not apply if defects are caused by product misuse or neglect, if the machine has been altered or modified by the buyer, or if other than genuine Eastman belts, emery wheels, knives or parts are used in the machine. THIS WARRANTY IS THE ONLY WARRANTY APPLICABLE TO THIS PURCHASE. SELLER DISCLAIMS ALL OTHER WARRANTIES, EXPRESS OR IMPLIED, INCLUDING, BUT NOT LIMITED TO, THE IMPLIED WARRANTIES OF MERCHANTABILITY AND FITNESS FOR A PARTICULAR PURPOSE.

Limitation of Liability. Eastman's liability to the buyer, and the buyer's remedies from Eastman, whether in contract, negligence, tort, under any warranty or otherwise, shall be limited to the remedies provided in the foregoing Limited Warranty. In no event shall Eastman have any responsibility or liability to the buyer for (a) any special, indirect, incidental, or consequential damages, including, but not limited to, loss of use, revenue, or profit, even if Eastman has been advised of the possibility of such damages, or (b) any claim against the buyer by any third party. The price stated for the product sold is a consideration for limiting Eastman's liability.