PFAFF[®] **471**

Unterklassen-Ausstattung
Subclass parts
Composition des sous-classes
Composición de las subclases

Unterklassen-Ausstattung¹⁾
Equipement des sous-classes¹⁾

Subclass organization¹⁾
Dotación de las subclases¹⁾

Unterklasse Subclass Sous-classe Subclase	Ausführung Model Version Tipo de máquina	Schneideabstand in mm Trimming margin in mm Distance de coupe en mm Márgen de corte en mm	Nadelstange Needle bar Barre à aiguille Barra de aguja	Stoffschieber Feed dog Griffe Transportador	Stichplatte ¹⁾ Needle plate Plaque à aiguille Placa de aguja	Nähfuß ¹⁾ Presser foot Pied presseur Pie prensateelas
-755/01	A; B		91-175 095-91	91-119 136-05	91-058 289-04	91-119 787-93
-755/01-900/..	A; B		91-175 095-91	91-119 136-05	91-058 223-04	91-119 787-93
-755/01-59/01	A		91-119 440-91	91-119 136-05	91-058 303-03 ¹⁾	91-119 681-93
-755/01-61/01	A		91-119 440-91	91-119 136-05	91-058 305-04	91-119 681-93
-755/01-725/04-900/..	A (1,0); A; B	A (1,0) = 0,8 A = 1,0-2,5 B = 1,2-2,5	91-175 095-91	91-119 136-05	91-058 555-93 ¹⁾	91-119 787-93
-755/01-725/04-940/02	A (1,0); A; B	A (1,0) = 0,8 A = 1,0-2,5 B = 1,2-2,5	91-175 095-91	91-119 136-05	91-058 497-93 ¹⁾	91-119 787-93
-755/01-725/04-906/05-940/02	B (1,8)	B = 1,3-3,5	91-175 095-91	91-119 136-05	91-058 497-93 ¹⁾	91-119 787-93
-755/01-940/02	A; B		91-175 095-91	91-119 136-05	91-058 497-93 x 2,5 ¹⁾	91-119 787-93

¹⁾ Die Liste enthält nur Nähwerkzeuge und Apparate. Beim Umbau in eine andere Unterklasse oder Ausführung sind auch noch Maschinenteile erforderlich. Geben Sie also bei Bestellungen die genaue Bezeichnung der vorhandenen und der gewünschten Ausführung bekannt.

¹⁾ This list contains sewing parts and attachments only. When converting to another subclass or version, machine parts are also necessary. When ordering please therefore indicate exactly the existing version and the one required.

¹⁾ Cette liste ne contient que les organes de couture et les guides. En cas de transformation en une sous-classe ou variante différente, il faut utiliser aussi certaines pièces de machine supplémentaires. En cas de commande, prière de toujours indiquer par conséquent les variantes disponibles et souhaitées.

¹⁾ Esta lista sólo contiene elementos de costura y aparatos. Siempre que haya que transformar la máquina en otro tipo o subclase, se necesitarán también piezas de máquina, por lo que deberá indicarse en los pedidos el tipo exacto de que se dispone y el deseado.

¹⁾ = Ausführung angeben
 = Indicate model
 = Préciser la version

¹⁾ = Nähmuster einsenden
 = Submit sewing sample
 = Joindre échantillons de couture

¹⁾ = Schneideabstand bei Bestellung angeben
 = State trimming margin on order
 = Indiquer la distance de coupe à la commande

Equipement des sous-classes¹⁾
Unterklassen-Ausstattung¹⁾

Dotación de las subclases¹⁾
Subclass organization¹⁾

Unterklasse Subclasse Sous-classe Subclase	Ausführung Model Version Tipo de máquina	Messer Knife Couteau Cuchilla	Fingerschutz Finger guard Garde-doigts Salvadoños	Apparat Attachment Appareil Aparato	Lineal Edge guide Guide-droit Guia recta	Bandführung Tape guide Guide ruban Guia para cinta	Bandtrommel Tape reel Tambour dérouleur Tambor portacintas	Bandrollhalter Tape reel bracket Support de plateau dérouleur Portarrollos
-755/01	A; B		91-053 938-91					
-755/01-900/..	A; B		91-053 938-91					
-755/01-59/01	A		91-053 938-91	91-050 859-93	91-056 512-91	91-493 979-21	91-041 644-91	91-053 983-91
-755/01-61/01	A		91-053 938-91	91-050 859-93	91-056 512-91	91-053 984-21		91-053 983-91
-755/01-725/04-900/..	A (1,0); A; B	91-119 202-05	91-053 938-91		91-050 932-91			
-755/01-725/04-940/02	A (1,0); A; B	91-119 202-05	91-053 938-91		91-050 932-91			
-755/01-725/04-906/05 -940/02	B (1,8)	91-119 202-05	91-053 938-91		91-050 932-91			
-755/01-940/02	A; B		91-053 938-91					

Unterklassen-Übersicht / Table of subclasses / Table des sous-classes / Tabla de subclases

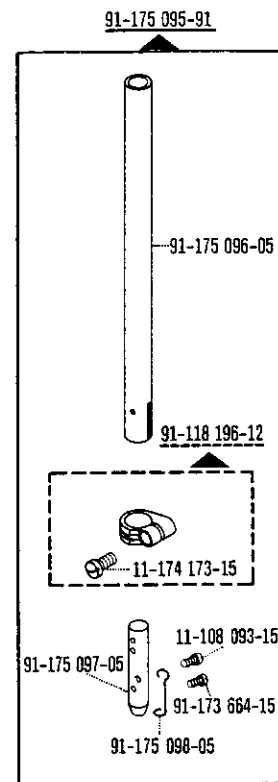
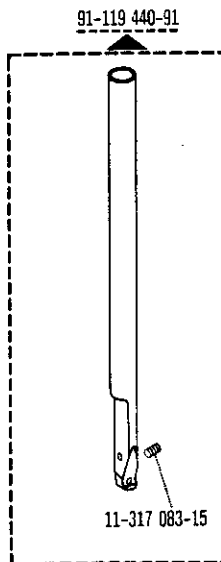

-755/01-59/01
-755/01-61/01

-755/01
-755/01-900/..
-755/01-725/04-900
-755/01-725/04-940
-755/01-725/04-906
-755/01-940/02

Unterklassen-Übersicht / Table of subclasses / Table des sous-classes / Tabla de subclases

91-119 136-05

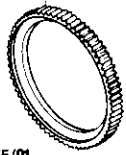

-755/01
 -755/01-900/..
 -755/01-59/01
 -755/01-61/01
 -755/01-725/04-900/..
 -755/01-725/04-940/02
 -755/01-725/04-906/05-940/02
 -755/01-940/02

91-058 223-04



-755/01-900/..

91-058 289-04



-755/01

91-058 303-03



-755/01-59/01

91-058 305-04



-755/01-61/01

91-058 497-93



-755/01-725/04-940/02
 -755/01-725/04-906/05-940/02
 -755/01-940/02

91-058 555-93



-755/01-725/04-900/..

91-119 681-93

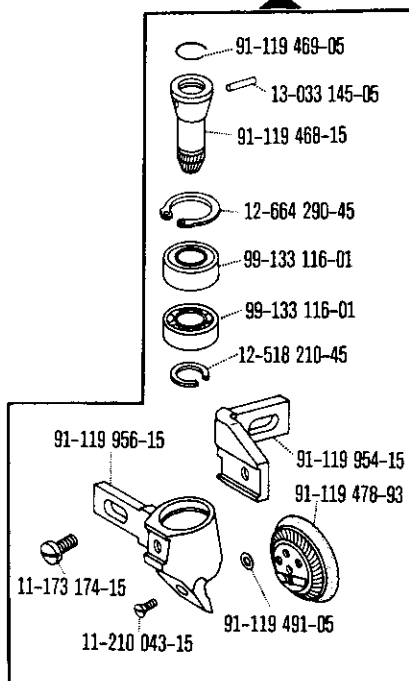

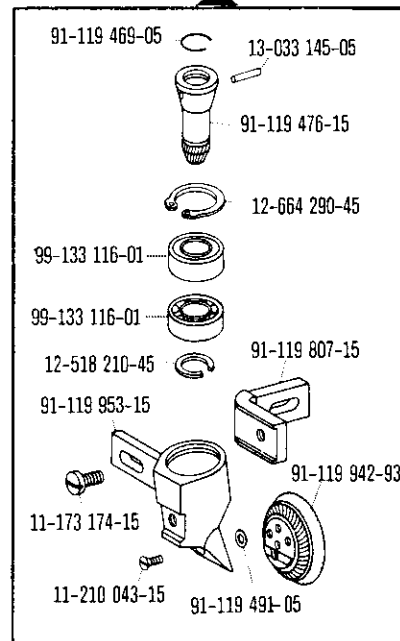

-755/01-59/01
 -755/01-61/01

91-119 787-93



-755/01
 -755/01-900/..
 -755/01-725/04-900/..
 -755/01-725/04-940/02
 -755/01-725/04-906/05-940/02
 -755/01-940/02

Unterklassen-Übersicht / Table of subclasses / Table des sous-classes / Tabla de subclases

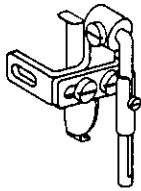
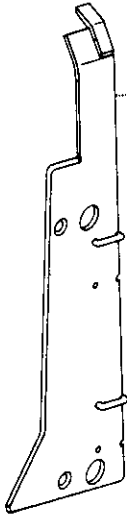
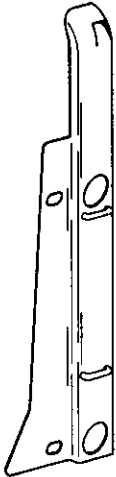
<p>91-119 202-05</p>  <p>-755/01-725/04-900/.. -755/01-725/04-940/02 -755/01-725/04-906/05-940/02</p>	<p>91-053 938-91</p>  <p>-755/01 -755/01-900/.. -755/01-59/01 -755/01-61/01 -755/01-725/04-900/.. -755/01-725/04-940/02 -755/01-725/04-906/05-940/02 -755/01-940/02</p>	<p>91-050 859-91 5</p>  <p>-755/01-59/01 -755/01-61/01</p>	
 <p>91-053 984-21</p> <p>-755/01-61/01</p>	<p>91-493 979-21</p>  <p>-755/01-59/01</p>		

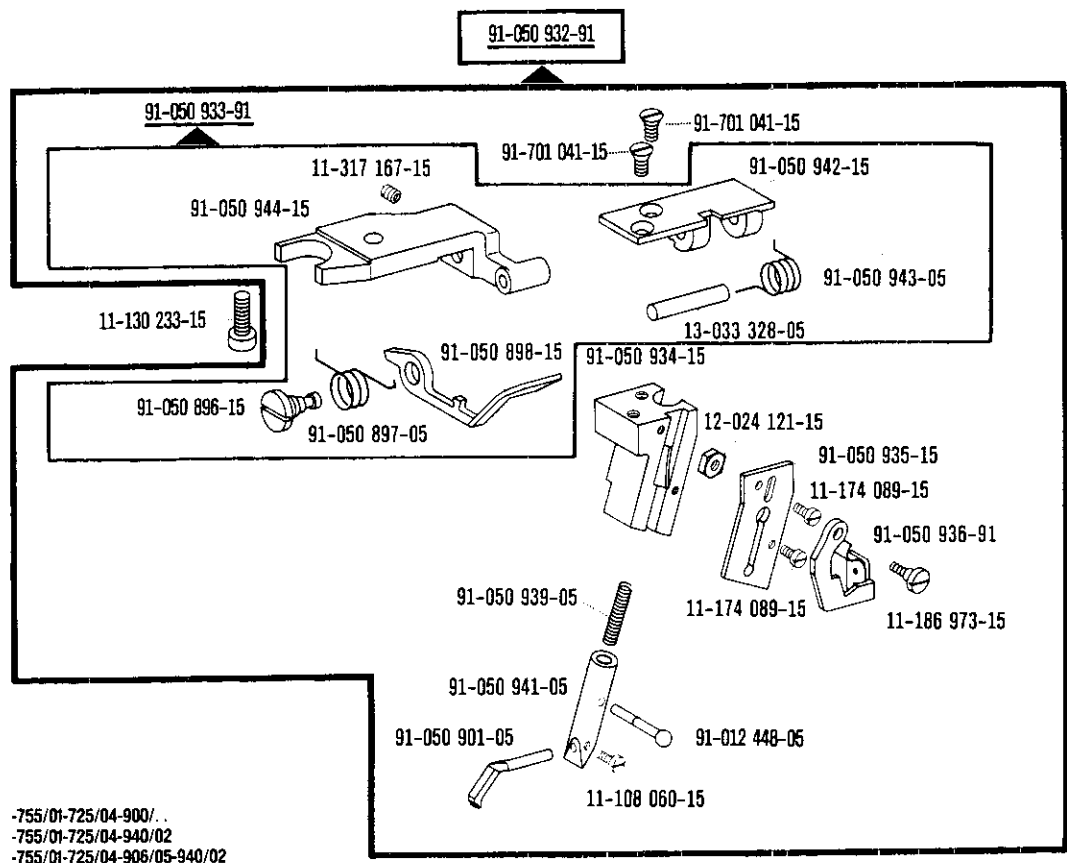

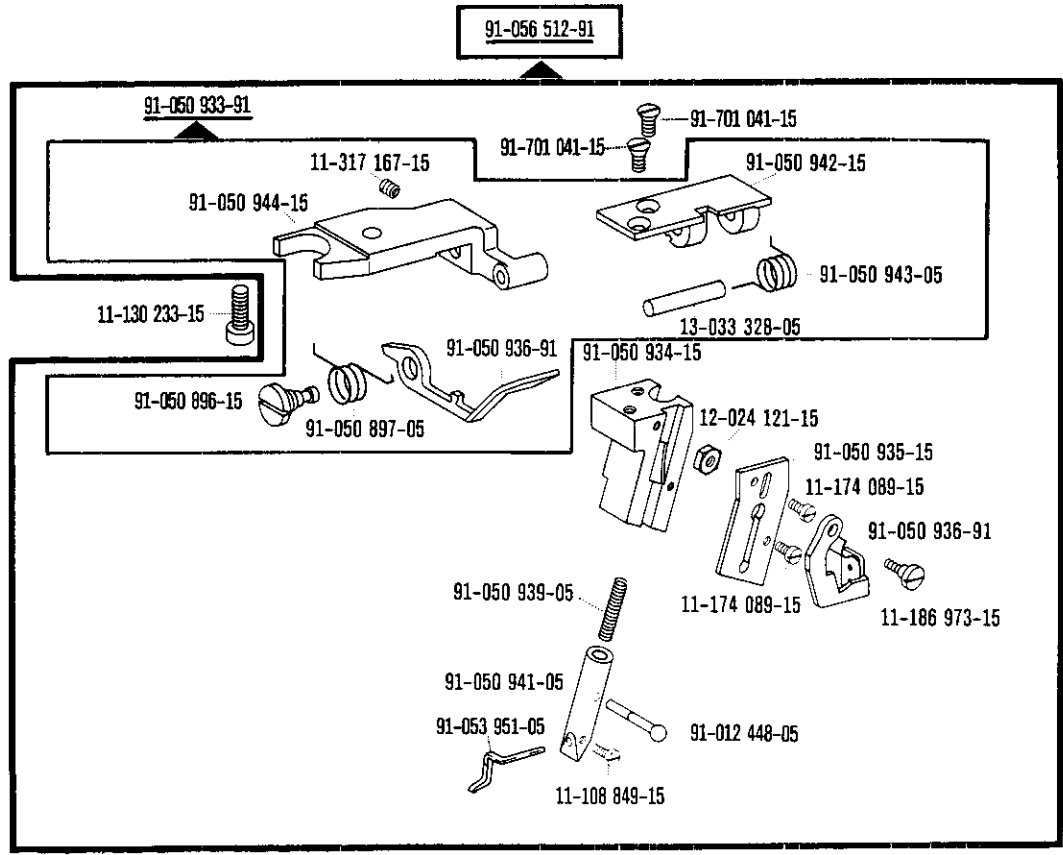

-755/01-59/01; -755/01-61/01

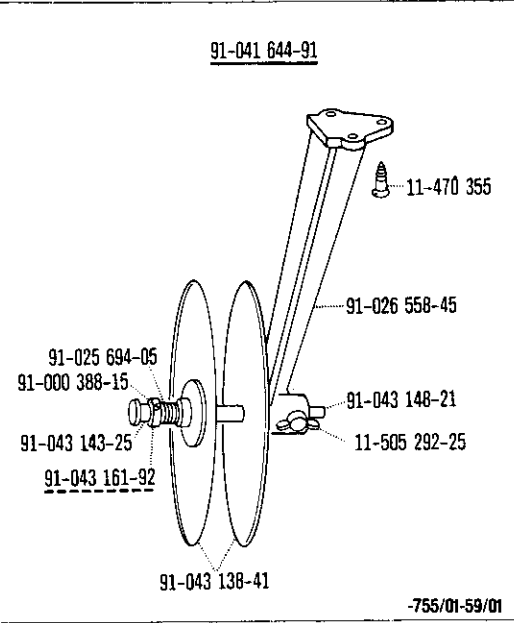

-755/01-59/01

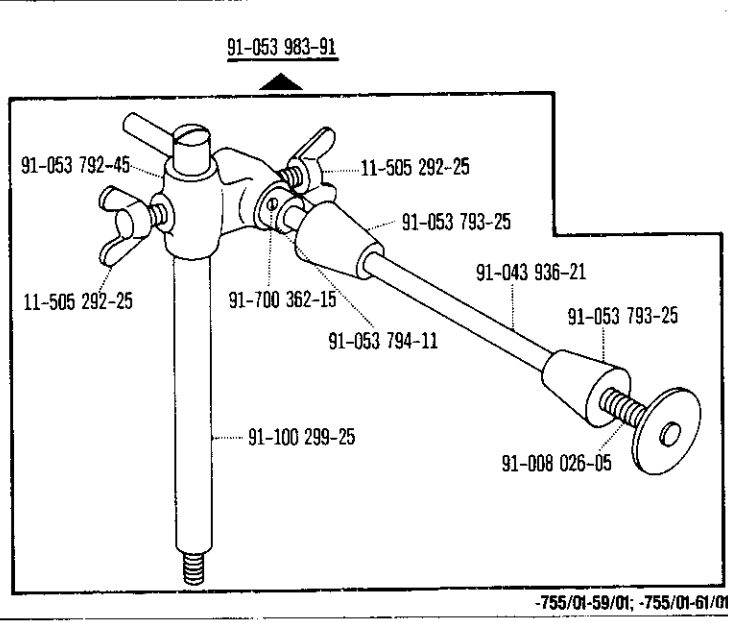

-755/01-59/01; -755/01-61/01

Pfaff, D 6750 Kaiserslautern, Postfach 3020/3040, Telex: 045753