

mitsubishi

三菱工業用ミシン部品カタログ

Industrial Sewing Machine Parts Catalog

Model PLK-E2516

	目次	CONTENTS	Page
A	本体構成	Construction	1
B	本体関係(1)	Arm bed & it's accessories (1)	2
C	本体関係(2)	Arm bed & it's accessories (2)	4
D	本体関係(3)	Arm bed & it's accessories (3)	6
E	縫い機構(1)	Sewing mechanism (1)	8
F	縫い機構(2)	Sewing mechanism (2)	10
G	中押え機構	Presser bar lifting mechanism	12
H	糸切り機構	Thread trimming mechanism	14
J	X-Yテーブル機構	X-Y table mechanism	16
K	外押え機構(1)	Work holder mechanism (1)	18
L	外押え機構(2)	Work holder mechanism (2)	20
M	ワイパー機構	Wiper mechanism	22
N	給油機構	Oil lubrication mechanism	24
P	配線・配管関係	Cable component & Pneumatic control unit	26
Q	テーブル関係	Table & Stand	28
R	付属品(1)	Accessories (1)	30
S	付属品(2)	Accessories (2)	32
T	オプションパーツ	Option parts	34
	索引	Index	36

部品コードの採番形式

MITSUBISHI SPARE PARTS No. Designation system

1. 部品コードについて CONCERNING PARTS CODE.

部品をご注文される場合は、部品コードをお知らせください。

Please inform the part number, when these parts are ordered.

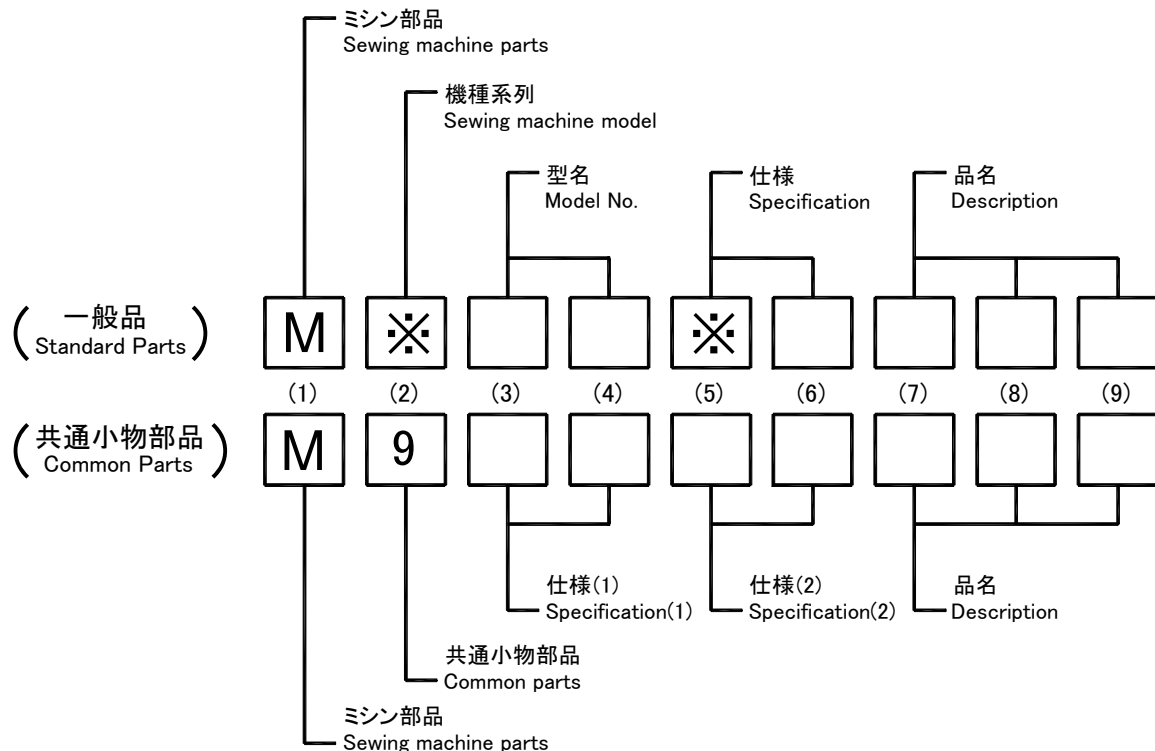

[例]
Example

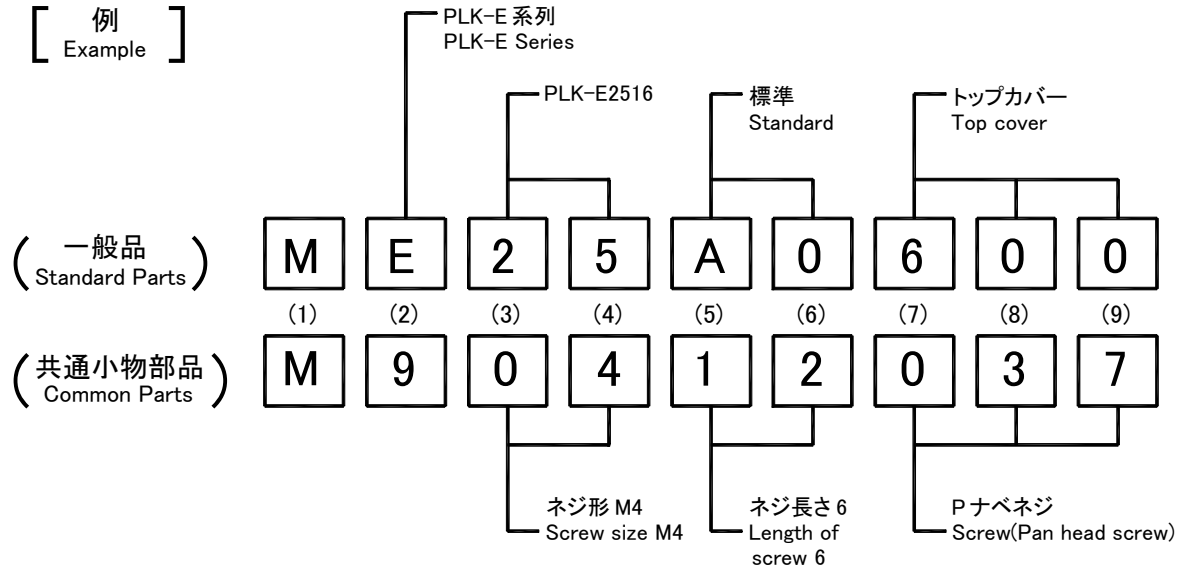

2. 変更マークについて CONCERNING MODIFICATION MARK.

変更マーク欄に*記号のある部品は、形状、寸法などの変更履歴がありますので、ご注文の際にはご使用の製品の製造番号と合わせてご覧ください。

The parts marked with * in the modification column has been changed the shape or size etc. So when these modified parts are ordered please inform the serial number of the sewing machine.

注: 一般品についての機種型名は、その部品が最初に使用された機種型名を示します。

従って長期にわたる場合は、機種の変更が行われるため、当初の機種以外の機種で使用されている場合があります。

Sewing machine Models, of Standard Parts are Indicated model of these parts are registered firstly. Parts are used for not only the indicated model, but also another models, in reason of New development, improvement after.

A 全体構成
CONSTRUCTION

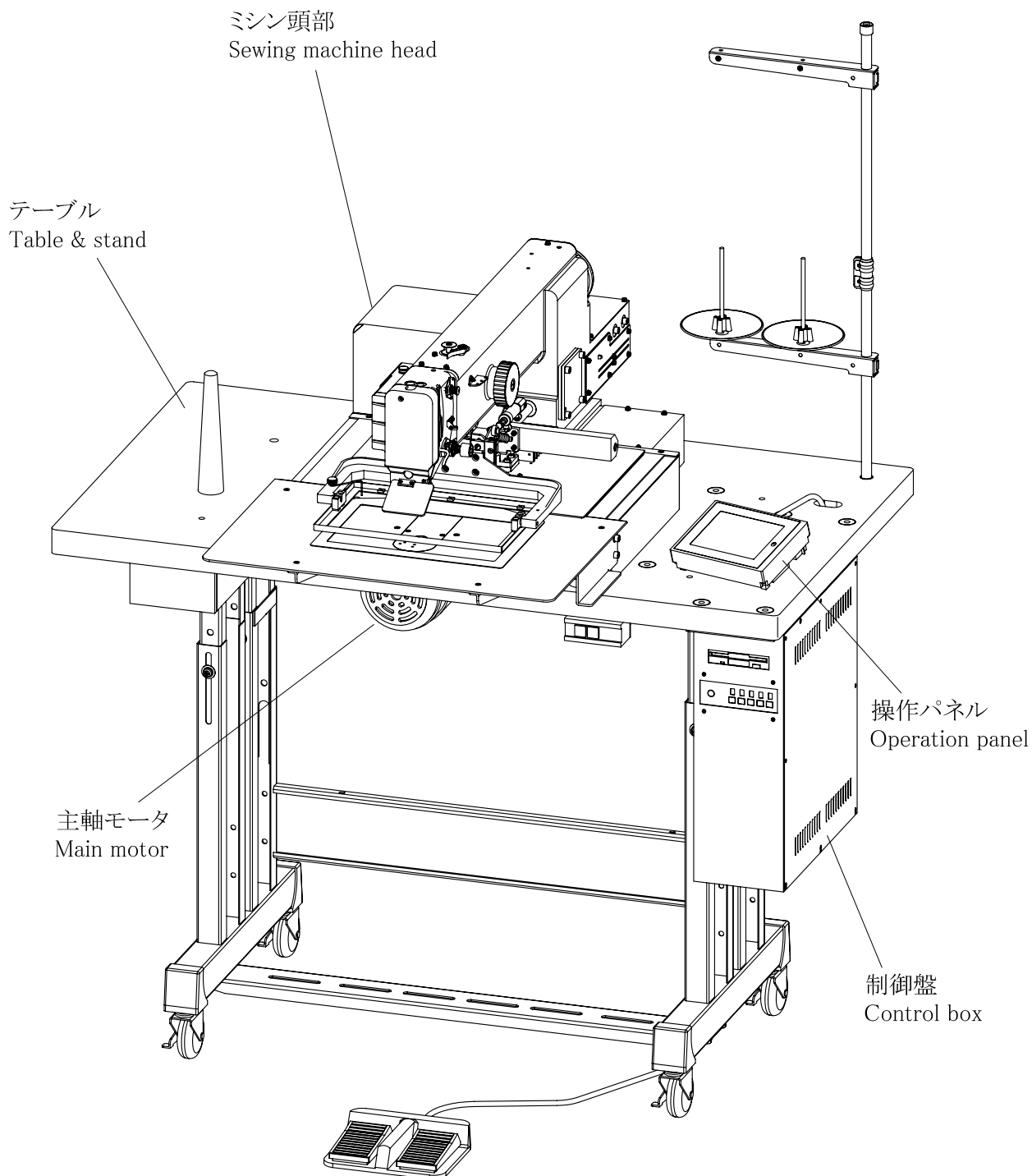

注1：モータ部分は三菱リミサーボX部品カタログを参照ください。

注2：Fig.No.の採番していない部品は単体で支給することは出来ません。Setにて支給いたします。

Remarks 1) Concerning about the motor parts please refer to the parts catalog of MITSUBISHI LIMISERVO X.

Remarks 2) The parts which Fig.No are not marked are not available individually. It can be supplied with the whole component.

B 本体関係(1)
 ARM BED & IT'S ACCESSORIES(1)

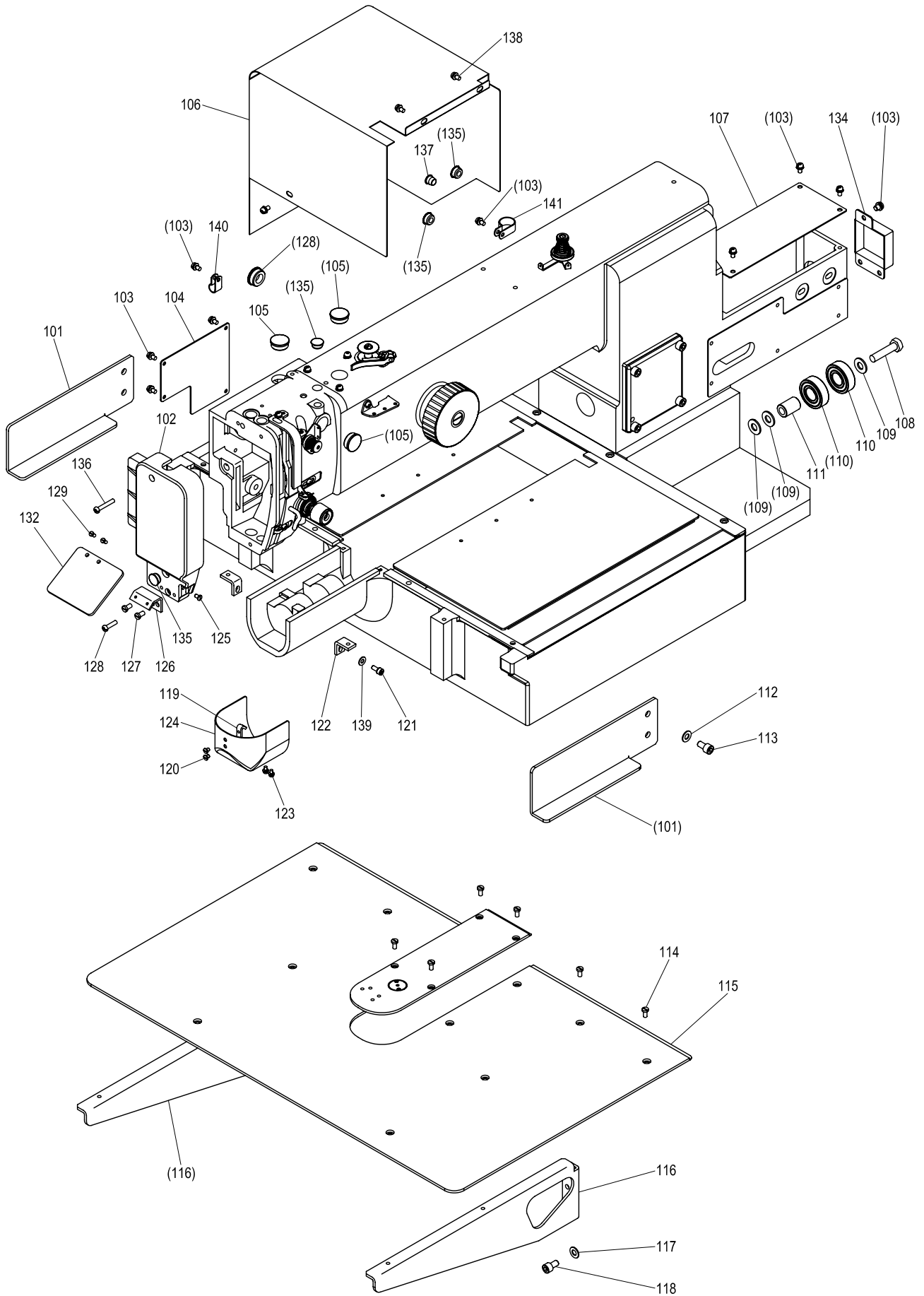

[B]本体関係(1)

ARM BED & IT'S ACCESSORIES(1)

Fig no.	変更 Mod.	部品コード Parts no.	品 名	Description	数量 Amt. Req.
B 101		MB61A0601	トリツケイタ	Holder	2
B 102	A	ME10E1830	メンイタ	Face cover	1
B 103		M91054004	SW-PWフライナヘネジ M4X8	Screw M4X8	16
B 104		ME10A0742	フタ	Cover	1
B 105		M91910080	ゴムセン φ19	Rubber plug φ19	4
B 106		MB62E0849	モータカバー	Motor cover	1
B 107		MB62A0339	カバー	Cover	1
B 108	A	M91803022	ロックアナツキボタンボルト M8X40	Bolt M8X40	1
B 109		M90823050	ミカキザガネ 8	Washer 8	3
B 110		MS10A1456	ジクウケ 6202ZZ	Bearing 6202ZZ	2
B 111		MB60A0750	ブッシュ	Bushing	1
B 112		M90631050	ザガネ 6	Washer 6	4
B 113		M96002017	セフティソケット M6X12	Bolt M6X12	4
B 114		M90990002	ヒラネジ M4X8	Screw M4X8	12
B 115		MB62A0470	スベリイタ	Slide plate	1
B 116		MB25A0426	ササエカナク	Support	2
B 117		M90511050	ザガネ 5	Washer 5	6
B 118		M95002017	セフティソケット M5X12	Bolt M5X12	6
B 119	A	MS01A0361	カケガネ	Latch	1
B 120		M90906003	マルヒラネジ 9/64(40)X3.2	Screw 9/64(40)X3.2	2
B 121		M94001017	セフティソケット M4X10	Bolt M4X10	2
B 122	A	MB62A4601	トリツケイタ	Bracket	2
B 123		M90859004	SW-PWフライナヘネジ M3X6	Screw M3X6	2
B 124	B	ME10B0339	シリンダカバー	Cylinder cover	1
B 125		M90909003	マルヒラネジ 9/64(40)X6	Screw 9/64(40)X6	1
B 126		MB60A0601	アイガードトリツケイタ	Eye guard bracket	1
B 127		M91110002	ヒラネジ 11/64(40)X8	Screw 11/64(40)X8	2
B 128	A	M91057004	SW-PWフライナヘネジ M4X20	Screw M4X20	1
B 129		M90806002	ヒラネジ 1/8(44)X6	Screw 1/8(44)X6	2
B 132		MS01A0160	アイガード	Eye guard	1
B 134		ME25A0339	カバー	Cover	1
B 135	A	M91182080	ゴムセン φ11.8	Rubber plug φ11.8	4
B 136	A	M91066004	SW-PWフライナヘネジ M4X25	Screw M4X25	1
B 137	A	M90883080	ゴムセン φ8.8	Rubber plug φ8.8	1
B 138	A	M91071004	SW-MWフライナヘネジ M4X8	Screw M4X8	3
B 139	A	M90421050	ザガネ 4	Washer 4	2
B 140	A	MN60A0620	ナイロンクリップ AB-5N	Nylon clip AB-5N	5
B 141	A	MB60A2620	ナイロンクリップ AB-10N	Nylon clip AB-10N	1

C 本体関係(2)
 ARM BED & IT'S ACCESSORIES(2)

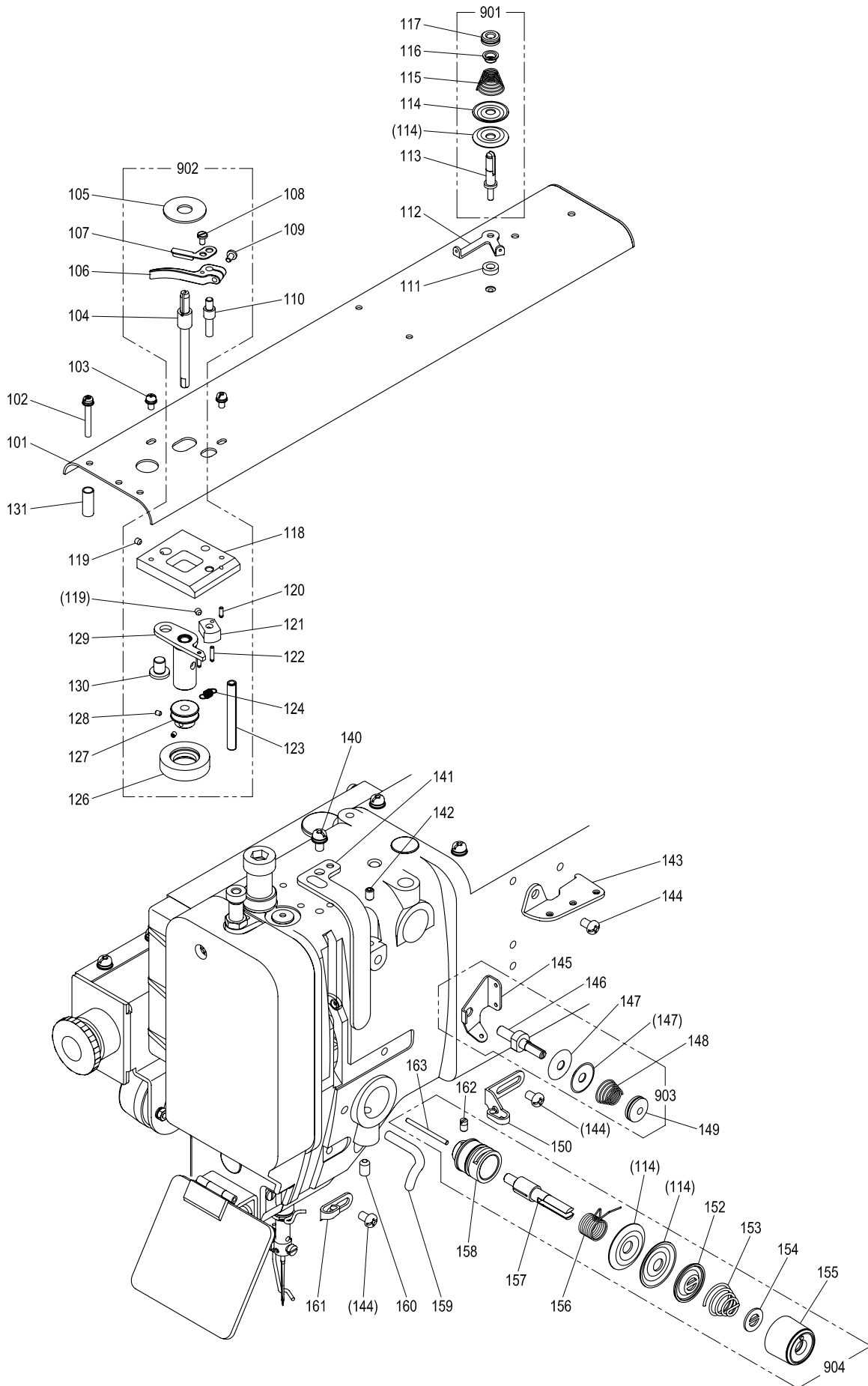

[C]本体関係(2)

ARM BED & IT'S ACCESSORIES(2)

Fig no.	変更 Mod.	部品コード Parts no.	部品名	Description	数量 Amt. Req.
C 101		ME25A0600	トップカバー	Top cover	1
C 102		M91276004	SW-PWフライナネジ M4X30	Screw M4X30	5
C 103	A	M91013004	SW-MWフライナネジ M4X10	Screw M4X10	2
C 104		MA04A1530	ダンツキシク D	Driven shaft	1
C 105		MA20A0476	スペーサー	Spacer	1
C 106		ME25A0950	レバ	Lever	1
C 107		ME25A0551	チョウセツキタ	Adjuster plate	1
C 108		M90920002	ヒラネジ 9/64(40)X6.5	Screw 9/64(40)X6.5	1
C 109		M90939002	ヒラネジ 9/64(40)X11	Screw 9/64(40)X11	1
C 110		ME25A0530	ダンツキシク	Shaft	1
C 111		MG75A1476	スペーサ	Spacer	1
C 112	A	MS14A1180	イトアンナイ	Thread guide	1
C 113		MS14A0553	チョウシホウ	Thread tension stud	1
C 114		MF10A0555	チョウシガラ	Thread tension discs	4
C 115		MM11A0245	エンスイバネ	Thread tension spring	1
C 116		MM11A0702	ハネアンナイ	Spring guide	1
C 117		M91602046	ツマミナット	Thumb nut	1
C 118		MB60A1601	トリツケイタ	Bracket	1
C 119		M91055020	ロッカクアナツキメネジ M4X4	Screw M4X4	2
C 120		M91004067	ミゾツキピン BXガタ φ2.5X8	Pin φ2.5X8	1
C 121		MS14A0350	カム	Cam	1
C 122		M91005067	ミゾツキピン BXガタ φ2.5X12	Pin φ2.5X12	2
C 123		M90601064	スプリングピン φ6X56	Pin φ6X56	1
C 124		MS14A0572	ツルマキバネ	Spring	1
C 126		MS03A0417	ゴムワ	Tire	1
C 127		MA20A0194	イマキグルマ	Wheel	1
C 128		M91057020	ロッカクアナツキメネジ M3X4	Screw M3X4	2
C 129	A	MB60E2750	レバークミタテ	Lever	1
C 130		M99006063	ピン	Pin	1
C 131		MB62A0352	スペーサ 1382312-60200	Spacer	5
C 140		M91054004	SW-PWフライナネジ M4X8	Screw M4X8	1
C 141		MA20A0584	テンピンカバー	Thread take-up lever guard	1
C 142		M91053020	ロッカクアナツキメネジ M4X6	Screw M4X6	1
C 143		MF36A1180	イトアンナイ	Thread guide	1
C 144		M91011004	フライナネジ M4X6	Screw M4X6	3
C 145		MF00A0181	イトアンナイ	Thread guide	1
C 146	A	MF90A0553	チョウシホウ	Thread tension stud	1
C 147		MF10A1555	チョウシガラ	Thread tension discs	2
C 148		MF36A0245	エンスイバネ	Thread tension spring	1
C 149		M91101046	ツマミナット	Thumb nut	1
C 150		MG43A0181	イトアンナイ	Thread guide	1
C 152		MM11A0556	チョウシガラオサエ	Disc retaining plate	1
C 153		MN52A1245	エンスイバネ	Thread tension spring	1
C 154		MT60A0802	マワリドメ	Thumb nut revolution stopper	1
C 155	A	M91610046	ツマミナット	Thumb nut	1
C 156		MF10A0187	イトリバネ	Thread take-up spring	1
C 157		MF10A0553	チョウシホウ	Thread tension stud	1
C 158		MF10A0709	ブッシュ	Regulator casing	1
C 159		MF70A1180	イトアンナイ	Thread guide	1
C 160		M95004020	ロッカクアナツキメネジ M5X8	Screw M5X8	1
C 161		MF10A0181	イトアンナイ	Thread guide	1
C 162		M90901002	ヒラネジ 9/64(40)X4	Screw 9/64(40)X4	1
C 163		M90204060	ピン	Pin	1
C 901		MS14E0180	チョウセツキミタテ	Thread tension Regulator assy	1
C 902		ME25E0190	イマキソウチクミタテ	Bobbin winder	1
C 903		MF00E0550	チョウセツキミタテ	Thread tension Regulator assy	1
C 904		MA16E0210	チョウセツキミタテ	Thread tension Regulator assy	1

D 本体関係(3)
ARM BED & IT'S ACCESSORIES(3)

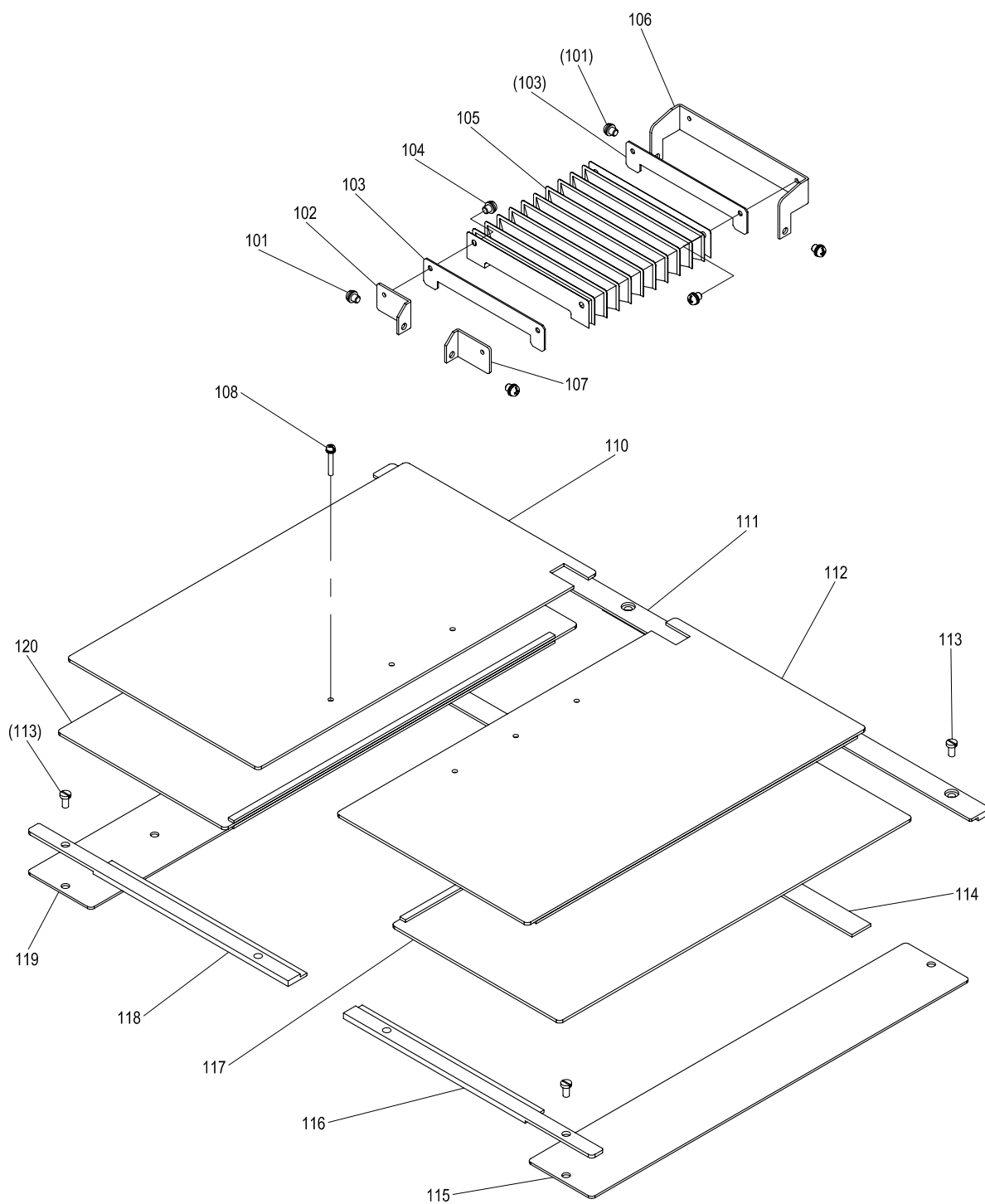

[D]本体関係(3)

ARM BED & IT'S ACCESSORIES(3)

Fig no.	変更 Mod.	部品コード Parts no.	品名	Description	数量 Amt. Req.
D 101		M91058004	SW-PWフライナベネジ M4X6	Screw M4X6	4
D 102		MB62A1601	ジャバラトリツケイタ (B)	Shutter adapter (B)	1
D 103		MA20A0257	オサエイタ	Shutter holder	2
D 104		M90859004	SW-PWツキフライネジ M3X6	Screw M3X6	4
D 105		MA20A0458	ジャバラ	Shutter	1
D 106		MB60A8601	ジャバラトリツケイタ	Shutter adapter	1
D 107		MB62A0601	ジャバラトリツケイタ (A)	Shutter adapter (A)	1
D 108		M90104036	PTラスネジ M3X16	Screw M3X16	6
D 110		MB62E2339	Xカバーイタ (ヒタリ)	X-cover plate (left)	1
D 111		MB62A2359	カバーガイド (ミキ)	Cover guide (right)	1
D 112		MB62E3339	Xカバーイタ (ミキ)	X-cover plate (right)	1
D 113		M90990002	ヒラネジ M4X8	Screw M4X8	8
D 114		MB62A1352	スペーサ	Spacer	1
D 115		MB62A7339	X-Yカバー (ヒタリ)	X-Y cover cover (left)	1
D 116	A	MB62A5352	スペーサ (ミキ)	Spacer (right)	1
D 117		MB62E4339	Xイトウカバー	X-movable cover	1
D 118	A	MB62A6352	スペーサ (ヒタリ)	Spacer (left)	1
D 119		MB62A6339	X-Yカバー (ミキ)	X-Y cover (right)	1
D 120		MB62E4339	Xイトウカバー	X-movable cover	1

E 縫い機構(1)
SEWING MECHANISM(1)

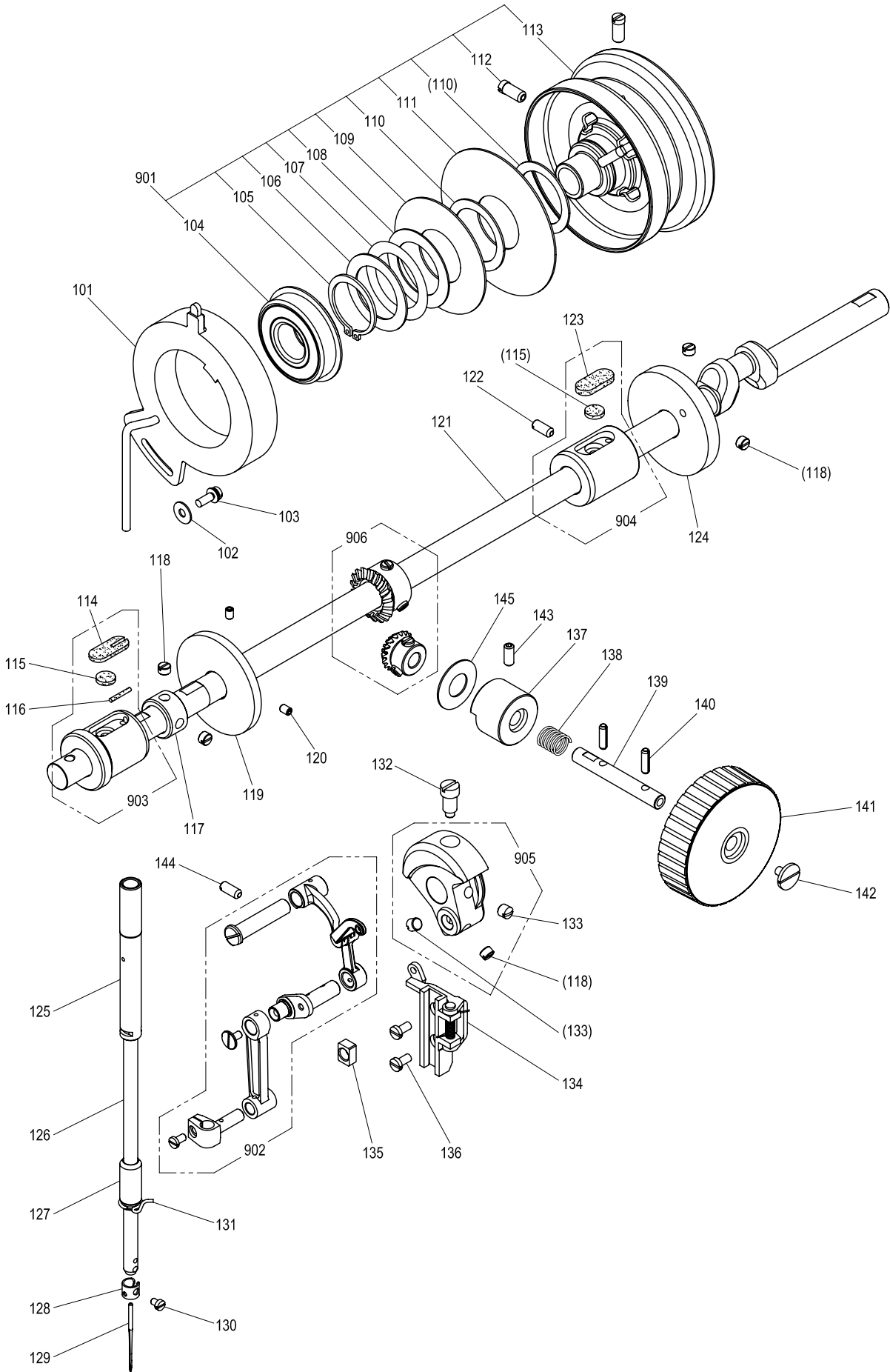

[E]縫い機構(1)

SEWING MECHANISM(1)

Fig no.	変更 Mod.	部品コード Parts no.	品名	Description	数量 Amt. Req.
E 101	B	ME20A0406	ウツクケンシュツキ	Detector	1
E 102	A	M90421050	ザガネ 4	Washer 4	1
E 103	A	M91059004	SW-PWフライマナネジ M4X12	Screw M4X12	1
E 104		MN10A1456	ボールベアリング	Ball bearing	1
E 105		M90330065	Cガ外ワ 30	C-type retaining ring 30	1
E 106		M93001050	ザガネ	Washer	1
E 107		MF01A0259	ナミザガネ	Wave washer	1
E 108		MF01A1476	スペーサー B	Spacer B	1
E 109		MN72A1694	ハンシャパン F20 (ウワイチ)	Command disk F20 (up)	1
E 110		MF01A0476	スペーサー A	Spacer A	2
E 111		MB60A0694	ハンシャパン K10 (シタイチ)	Command disk K10 (down)	1
E 112		M91520002	ヒラネジ 15/64(28)X12	Screw 15/64(28)X12	2
E 113		MB60E0682	プーリ	Pulley	1
E 114		MG50A0740	フェルト	Felt	1
E 115		MS10A1740	フェルト	Felt	2
E 116		MV88A0740	フェルト	Felt	1
E 117		MF70A0352	カラー	Collar	1
E 118		M91602001	トメネジ 1/4(40)X4	Screw 1/4(40)X4	5
E 119		MS14A0682	イトマキプーリ	Pulley	1
E 120		M91053020	ロッカクアナツキトメネジ M4X6	Screw M4X6	2
E 121		ME25A0230	ウツク	Drive shaft	1
E 122	B	M95003001	トメネジ M5X12	Screw M5X12	1
E 123		MF60A2740	フェルト	Felt	1
E 124		MS01A0350	イトキリカム	Thread trimmer cam	1
E 125		MS01A0663	ハリボウメタル (ウエ)	Needle bar bushing (upper)	1
E 126		MS01A0660	ハリボウ	Needle bar	1
E 127		MG30A0664	ハリボウメタル (シタ)	Needle bar bushing (lower)	1
E 128		MF21D0181	イトアンナイ	Thread guide	1
E 129		MS02A0128	ミシンハリ DPX17#18	Needle DPX17#18	1
E 130		M90815002	ヒラネジ 1/8(44)X4.5	Screw 1/8(44)X4.5	1
E 131		MF01A0181	イトアンナイ	Thread guide	1
E 132		M91802006	ヒラネジボウサキ 9/32(28)	Set screw 9/32(28)	1
E 133		M91606001	トメネジ 1/4(40)X6	Screw 1/4(40)X6	2
E 134		MS03E0662	ハリカイトクミタテ	Guide assy	1
E 135		MF10A0325	カクコマ	Square block	1
E 136		M90990002	ヒラネジ M4X8	Screw M4X8	2
E 137		ME25A0833	メタル	Bushing	1
E 138		MA35A2572	ツルマキバネ	Spring	1
E 139		ME25A0454	ジク	Shaft	1
E 140		M90406064	スプリングピン φ4X14	Pin φ4X14	2
E 141		ME25A0682	テマワシプーリ	Hand pulley	1
E 142		M91119002	ヒラネジ	Screw M4X8	1
E 143	A	M95006020	ロッカクアナツキトメネジ M5X12	Screw M5X12	1
E 144	A	M91221001	トメネジ M5X12	Screw M5X12	1
E 145	B	ME25A0416	カンショウゴム	Rubber plate	1
E 901		MB60E1682	プーリクミタテ	Pulley assy	1
E 902		MS01E0580	テンピンハリクミタテ	Thread take-up lever assy	1
E 903		MS10A0232	ウツクメタル(ヒタリ)クミ	Drive shaft bushing L assy	1
E 904		MB60E0234	ウツクメタル(ナカ)クミ	Drive shaft bushing C assy	1
E 905		MS01A0383	クランククミ	Crank assy	1
E 906		ME25E0331	カサハグルマクミ	Bevel gear assy	1

F 縫い機構(2)
SEWING MECHANISM(2)

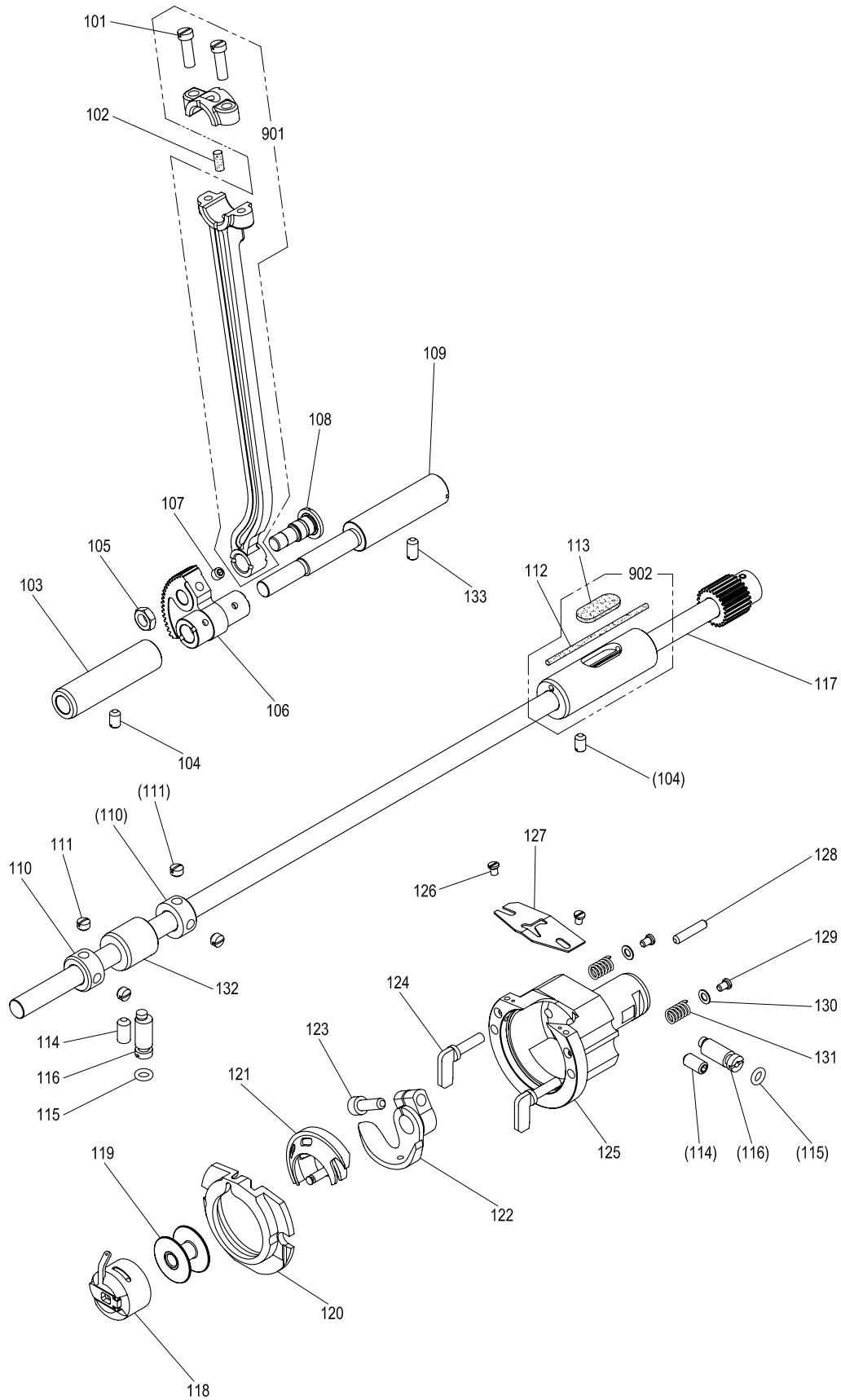

[F]縫い機構(2)

SEWING MECHANISM(2)

Fig no.	変更 Mod.	部品コード Parts no.	品名	Description	数量 Amt. Req.
F 101		M91203002	ヒラネジ 3/16(28)X15	Screw 3/16(28)X15	2
F 102		MB60A0740	フェルト	Felt	1
F 103		MS01A0833	メタル	Bushing	1
F 104	A	M95002001	スリワリトメネジ M5X6	Screw M5X6	1
F 105		M91802045	ナット 9/32(28)	Nut 9/32(28)	1
F 106		MS01A0508	セクタハグルマ	Sector gear	1
F 107		M95004021	ロックアナツキトメネジ M5X5	Screw M5X5	1
F 108		M98003015	ヒラネジダツキ 9/32(28)	Screw 9/32(28)	1
F 109		MS01A0891	ヨウトウシク	Rock shaft	1
F 110		MM11A0352	カラー	Collar	2
F 111		M91503001	トメネジ 15/64(28)X4.5	Screw 15/64(28)X4.5	4
F 112		ME10A0148	ヒモ	Oil braid	1
F 113		MA20A0740	フェルト	Felt	1
F 114	A	M96002020	ロックアナツキトメネジ M6X12	Screw M6X12	2
F 115		M90500085	O リング	O-ring	2
F 116		MS01A0761	ヘンジンシク	Eccentric shaft	2
F 117		MB62E0450	シタジク クミ	Hook shaft assy	1
F 118		MS17A0125	ホビンケース SC-181	Bobbin case	1
F 119		MA10A0123	ホビン	Bobbin	1
F 120		MS08A0616	ナカガマオサエ	Hook retainer	1
F 121		MA10A0120	ナカガマ	Inner hook	1
F 122		MS01A0611	ドライハ	Hook driver	1
F 123		M95001021	ロックアナツキボルト M5X16	Bolt M5X16	1
F 124		MS09A0950	カマオサエツツミ	Hook clamp	2
F 125		MS01A0121	ソトガマ	Outer hook	1
F 126		M90853002	ヒラネジ 1/8(40)X4	Screw 1/8(40)X4	2
F 127		MS01A0329	カマイトアンナイ	Thread guide	1
F 128		M90001060	ヘイコウピン M6-4X18	Pin M6-4X18	1
F 129		M90802003	マルヒラネジ 1/8(44)X4.5	Screw 1/8(44)X4.5	2
F 130	B	M93023050	ザガネ	Washer	2
F 131		MS01A0572	ツルマキハネ	Spring	2
F 132	A	MB62A0453	シタジクメタル(ナカ)	Hook shaft bushing (C)	1
F 133	A	M95003001	スリワリトメネジ M5X12	Screw M5X12	1
F 901	A	MB62E0956	レンセツカン クミ	Connecting rod assy	1
F 902		ME10E0452	シタジクメタル(ミキ)クミ	Hook shaft bushing (R) assy	1

G 中押え機構
PRESSER BAR LIFTING MECHANISM

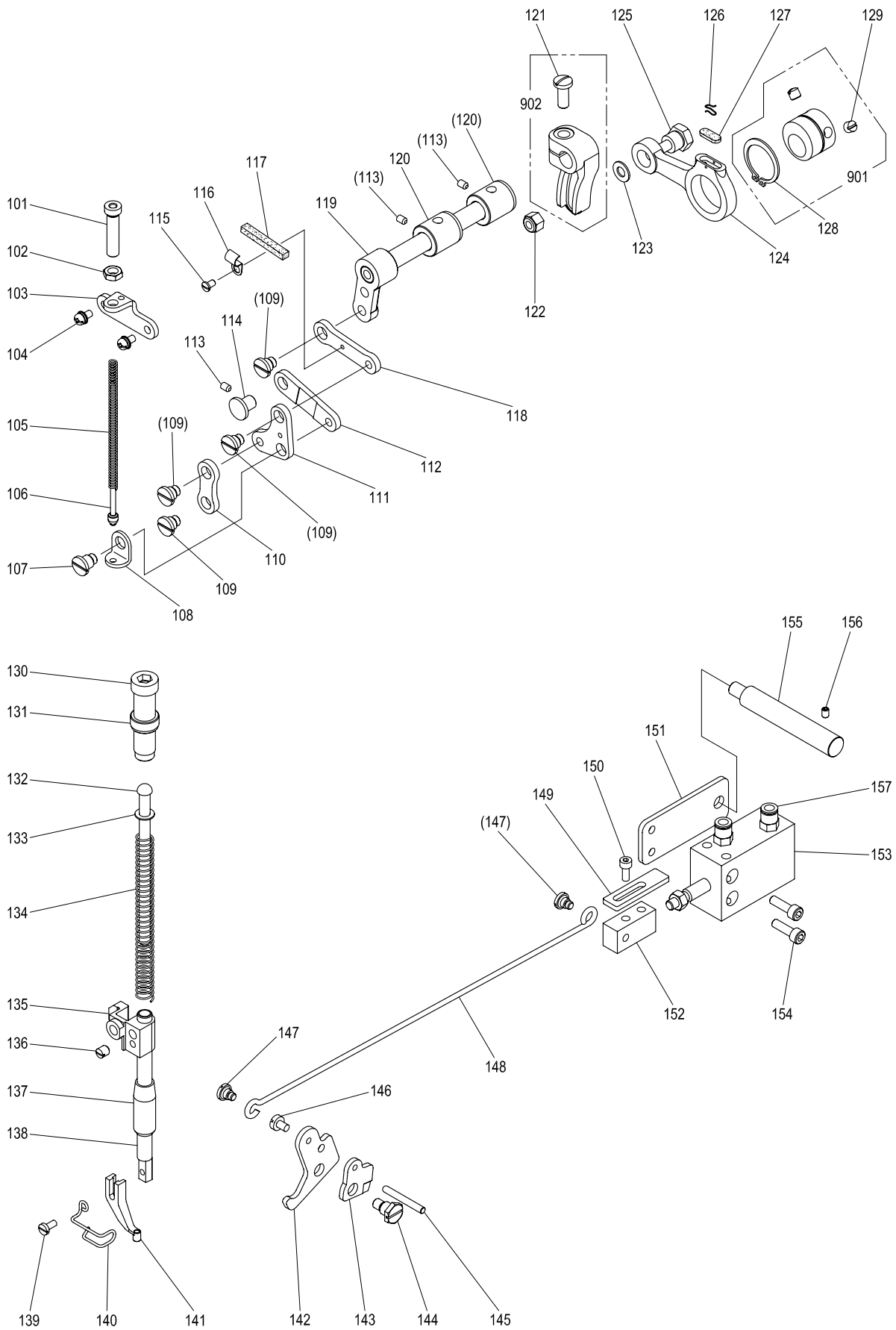

[G]中押え機構

PRESSER BAR LIFTING MECHANISM

Fig no.	変更 Mod.	部品コード Parts no.	品名	Description	数量 Amt. Req.
G 101		M91801035	ツマミネジ 9/32(28)X35	Thumb screw 9/32(28)X35	1
G 102		M91802045	ナット 9/32(28)	Nut 9/32(28)	1
G 103		ME10A0261	オサエチヨウセツダイ	Bracket	1
G 104	A	M91056004	SW-PWアラマイナベネジ M4X10	Screw M4X10	2
G 105		ME10A0572	ツルマキハネ	Spring	1
G 106		MS03A6154	アンナイガネ	Spring guide bar	1
G 107		M91689015	ヒラネジダンツキ 1/4(40)	Screw 1/4(40)	1
G 108		MG30B0226	オサエイタサエ	Supporter	1
G 109		M91688015	ヒラネジダンツキ 1/4(40)	Screw 1/4(40)	4
G 110		ME10A6910	リンク	Link	1
G 111		ME10A0763	ベルクランク	Bell crank	1
G 112		ME10A7910	リンク	Link	1
G 113	A	M91058020	ロッカクアナツキトメネジ M4X10	Screw M4X10	3
G 114		M99006063	ツハツキシク	Pin	1
G 115	A	M90909003	マルヒラネジ 9/64(40)X6	Screw 9/64(40)X6	1
G 116		MN70A1780	ホルダ	Holder	1
G 117		MG30A0740	フェルト	Felt	1
G 118		ME10A1956	レンセツカン	Link	1
G 119		MS02E0460	ウデクミタテ	Arm shaft assy	1
G 120		MG30A0833	メタル	Bushing	2
G 121		M91603003	マルヒラネジ 1/4(40)X16	Screw 1/4(40)X16	1
G 122		M91572045	U ナット 6X0.75	U-nut 6X0.75	1
G 123		M90631050	サガネ 6	Washer 6	1
G 124		ME10A0956	レンセツカン	Crank rod	1
G 125		M91551015	ホルトダンツキ M6	Bolt M6	1
G 126		MF60A0700	センサイクハネ	Holder	1
G 127		MG30B0740	フェルト	Felt	1
G 128		M90325065	Cガ外メワ 25	C-type retaining ring 25	1
G 129		M91606001	トメネジ 1/4(40)X6	Screw 1/4(40)X6	2
G 130	A	M93220035	ツマミネジ 1/2(28)X43	Thumb screw 1/2(28)X43	1
G 131		M93202047	ナット 1/2(28)	Nut 1/2(28)	1
G 132		MS03A0703	アンナイボウ	Presser bar guide	1
G 133		M90632050	コサガネ 6	Washer 6	1
G 134		MS03A1572	ツルマキハネ	Spring	1
G 135		MG75A0265	オサエボウダキ	Presser bar holder	1
G 136		M91506001	トメネジ 15/64(28)X6	Screw 15/64(28)X6	1
G 137		MF10A0267	オサエボウメタル	Bushing	1
G 138		MS03A0262	オサエボウ	Presser bar	1
G 139		M90922002	ヒラネジ 9/64(40)X8	Screw 9/64(40)X8	1
G 140		MB62A0626	ニードルガード	Needle guard	1
G 141		MV30A0256	オサエ φ3	Presser foot φ3	1
G 142		ME10A1252	オサエアケレバ	Lifting lever	1
G 143		MF70A0350	イトルメカム	Plate cam	1
G 144	A	M91504031	ホルト 15/64(28)	Bolt 15/64(28)	1
G 145		M90423060	イトルメピン	Pin	1
G 146		M91131002	ヒラネジ 11/64(40)X6.5	Screw 11/64(40)X6.5	1
G 147		M91219015	ヒラネジダンツキ 3/16(28)	Screw 3/16(28)	2
G 148		ME25A0738	ヒキボウ	Link	1
G 149		ME25A0477	ストッパ	Stopper	1
G 150		M95003017	セフティソケット M5X8	Bolt M5X8	2
G 151		ME25A0601	トリツケイタ	Adapter	1
G 152		ME25A0571	ジョイント	Joint	1
G 153		ME25A0434	エアシリンダ	Air cylinder	1
G 154		M95006017	セフティソケット M5X22	Bolt M5X22	2
G 155		ME25A1454	ジク	Shaft	1
G 156		M95004020	ロッカクアナツキトメネジ M5X8	Screw M5X8	1
G 157	A	ME40A0571	ワンタッチツキテ	Connector	1
G 901		MG30A0760	ヘンシンリンクミタテ	Eccentric cam assy	1
G 902		MS02A0463	ウデ (ミキ)	Arm (right)	1

H 糸切り機構
THREAD TRIMMING MECHANISM

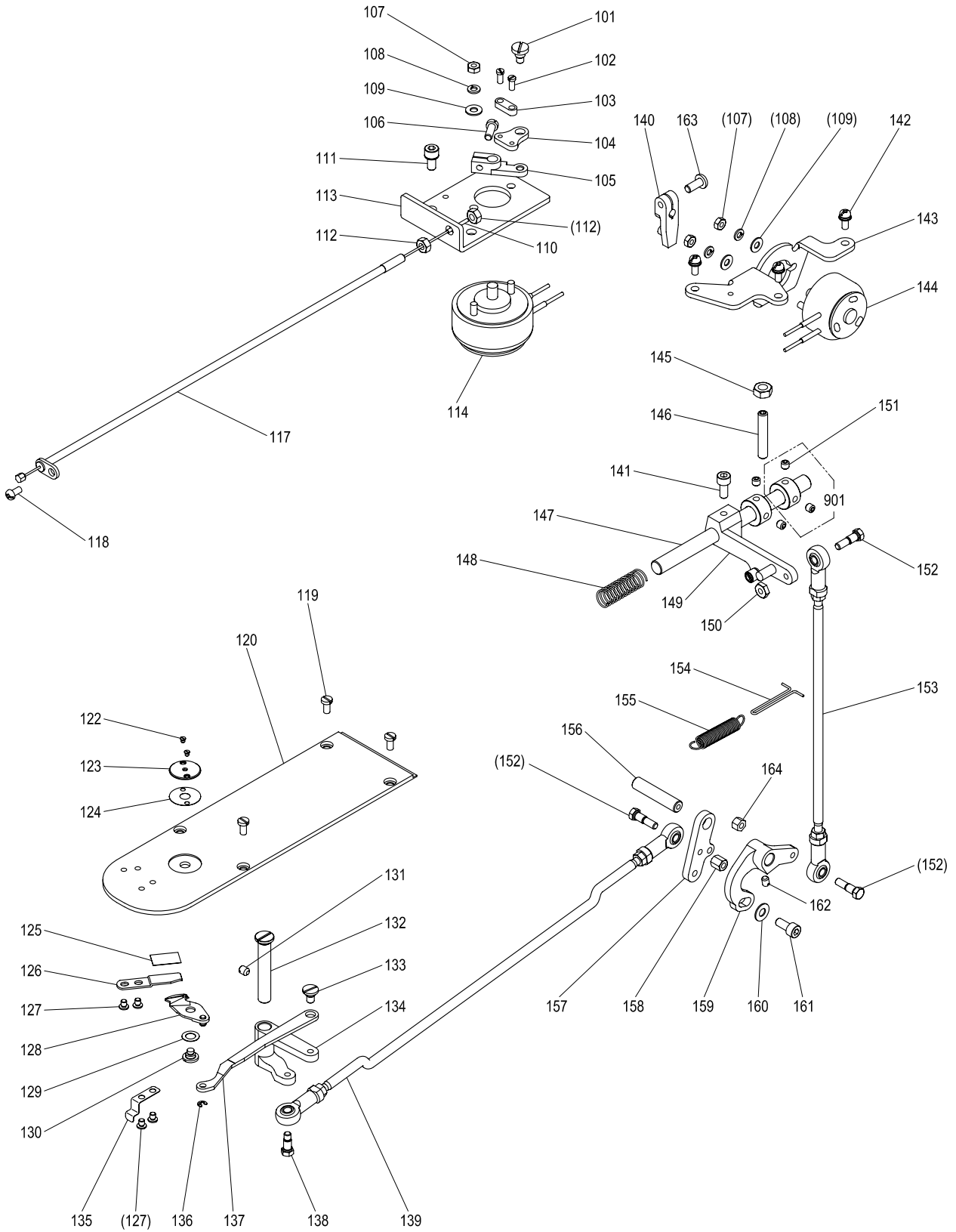

[H]糸切り機構

THREAD TRIMMING MECHANISM

Fig no.	変更 Mod.	部品コード Parts no.	品名	Description	数量 Amt. Req.
H 101		M91127015	ヒラネジ ^ダ ンツキ 11/64(40)	Screw 11/64(40)	1
H 102	A	M90825002	ヒラネジ 1/8(44)X10	Screw 1/8(44)X10	2
H 103		MF36A0750	ホルダ	Holder	1
H 104		MF90A0361	カガネ	Bracket	1
H 105		MS07A0228	ウデ	Crank	1
H 106		M91112002	ヒラネジ 11/64(40)X12	Screw 11/64(40)X12	1
H 107	A	M91007045	ナット M4	Nut M4	4
H 108		M90424053	ハネサ ^ガ ネ 4	Spring washer 4	4
H 109	A	M90422050	サ ^ガ ネ 4	Washer 4	4
H 110		MN60A0750	プッシュ	Pipe	1
H 111		M95005017	セフティソケット M5X10	Bolt M5X10	2
H 112		M91382045	ナット M5	Nut M5	2
H 113		MA20A0603	ソレノイドトリツケイタ	Solenoid bracket	1
H 114	A	MB61E0519	イト ^コ ルメソレノイド	Solenoid (thread release)	1
H 117		MA10E0746	フレキシブルワイヤ	Flexible wire assy	1
H 118	A	M91054004	プ ^ラ マイナ ^ハ ネジ M4X8	Screw M4X8	1
H 119		M90990002	ヒラネジ M4X8	Screw M4X8	4
H 120		MB62A1470	ス ^ペ リイタ	Slide plate	1
H 122		M90605010	サラネジ 3/32(56)X2.8	Screw 3/32(56)X2.8	2
H 123		MS03A1101	ハリイタ φ2.2	Needle plate	1
H 124		MS01A1476	ス ^ペ ーサ	Spacer	1
H 125		MA10B2476	ス ^ペ ーサ	Spacer	1
H 126		MS14A0838	コ ^テ イメス	Fixed knife	1
H 127		M90906003	マルヒラネジ 9/64(40)X3.2	Screw 9/64(40)X3.2	4
H 128		MS03B0838	イト ^ウ メス	Movable knife	1
H 129		M96004052	ウェーブワッシャ 6	Wave washer 6	1
H 130		M91129015	ヒラネジ ^ダ ンツキ 11/64(40)	Screw 11/64(40)	1
H 131	A	M91224001	トメネジ M5X8	Screw M5X8	1
H 132		MB62A0454	ツ ^ハ ツキシク	Stepped pin	1
H 133		M91214015	ヒラネジ ^ダ ンツキ 3/16(28)	Screw 3/16(28)	1
H 134		MA20A0392	メ ^ス ク ^ト ウウテ (3)	knife driving crank (3)	1
H 135		MS01A0192	イ ^タ ハ ^ネ	Leaf spring	1
H 136		M90513065	E ^ガ 外 ^メ ワ 2.5	E-type retaining ring 2.5	1
H 137		MA20A1910	リンク	Link	1
H 138	A	M91101017	ボルト ^ダ ンツキ 11/64(40)	Bolt 11/64(40)	1
H 139		MB62E0975	ロ ^ッ ト ^エ ント ^ク ミ ^タ テ (ヨコ)	Connecting rod (horizontal)	1
H 140		MS01E0430	イト ^キ リサ ^ト ウウテ	Crank	1
H 141		M95003021	ロ ^ッ カ ^ク ア ^ナ ツ ^キ ボ ^{ルト} M5X12	Bolt M5X12	1
H 142		M91056004	SW- ^{PW} プ ^ラ マイ ^ナ ハ ^ネ ジ M4X10	Screw M4X10	3
H 143		MS14A3601	ソ ^レ ノ ^イ ド ^ト リ ^ツ ケ ^イ タ	Solenoid bracket	1
H 144	A	MB05E0519	イト ^キ リ ^ソ レ ^ノ イ ^ド	Solenoid (thread trim)	1
H 145		M91576045	ナット M6	Nut M6	1
H 146		M91652020	コ ^ネ ジ M6X35	Screw M6X35	1
H 147		MS01A0348	カ ^ム シク	Shaft	1
H 148		MS01A1572	ツ ^ル マ ^キ ハ ^ネ	Spring	1
H 149		MS01E0351	カ ^ム ツ ^イ ジ ^ユ ウ ^ウ テ ^ク ミ	Cam follower assy	1
H 150		M91104045	ナット 11/64(40)	Nut 11/64(40)	1
H 151		M95004021	ロ ^ッ カ ^ク ア ^ナ ツ ^キ ト ^メ ネ ^ジ M5X5	Screw M5X5	4
H 152		M90101017	ボ ^{ルト} ダ ^ン ツ ^キ 11/64(40)	Bolt 11/64(40)	3
H 153		MS01E0975	ロ ^ッ ト ^エ ント ^ク ミ ^タ テ (タテ)	Connecting rod (vertical)	1
H 154		MS08A0708	ハ ^ネ カ ^ケ	Hook	1
H 155		MS01A2572	ツ ^ル マ ^キ ハ ^ネ	Spring	1
H 156		MS08A0454	シク	Shaft	1
H 157		MS01A2392	メ ^ス ク ^ト ウウテ (2)	knife driving crank (2)	1
H 158		M91109045	ロ ^ン グ ^ナ ット 11/64(40)	Long nut 11/64(40)	1
H 159		MS01A1392	メ ^ス ク ^ト ウウテ (1)	knife driving crank (1)	1
H 160		M90511050	サ ^ガ ネ 5	Washer 5	1
H 161	A	M95002017	セフティソケット M5X12	Bolt M5X12	2
H 162		M91108001	トメネジ 11/64(40)X5.5	Screw 11/64(40)X5.5	1
H 163	A	M95051021	ロ ^ッ カ ^ク ア ^ナ ツ ^キ ボ ^{ルト} M5X12	Molt M5X12	1
H 164	A	M91102045	ナット 11/64(40)	Nut 11/64(40)	1
H 901		MS01A3352	カ ^ラ ー ^ク ミ	Collar assy	2

J X-Yテーブル機構
X-Y TABLE MECHANISM

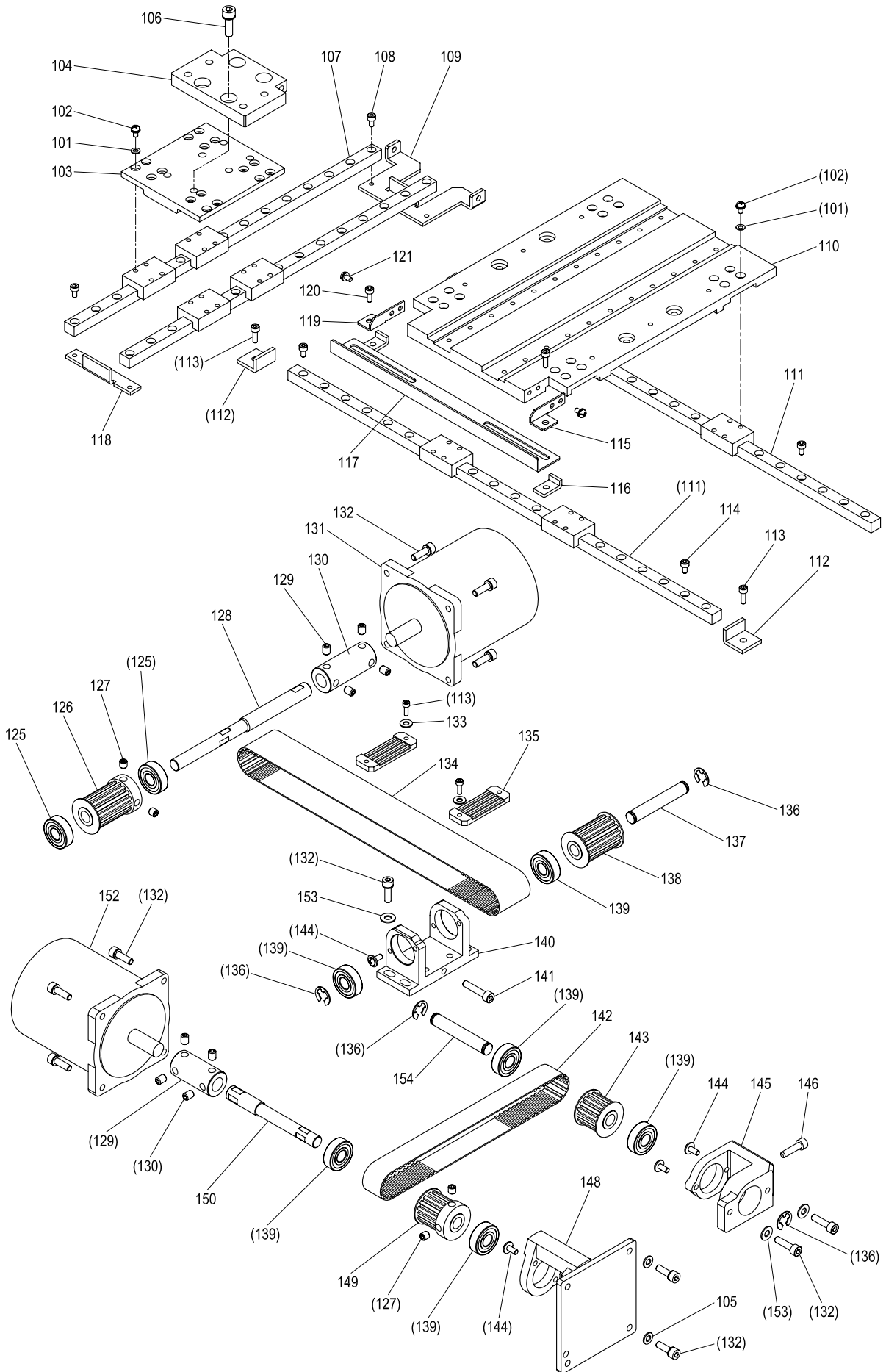

[J]X-Yテーブル機構
X-Y TABLE MECHANISM

Fig no.	変更 Mod.	部品コード Parts no.	品名	Description	数量 Amt. Req.
J 101		M90317050	ザガネ 3	Washer 3	32
J 102		M90814004	プラマイナヘネジ M3X5.2	Screw M3X5.2	32
J 103		MB62E0957	Yジクイトウレース	Y-movable race	1
J 104		MB62E2601	オサエタイトリツケイタ	Clamp adapter	1
J 105		M90512050	ザガネ 5	Washer 5	4
J 106	A	M95002017	セフティソケット M5X12	Bolt M5X12	4
J 107	A	MA20A5920	リアウエイ (Y)	Y-liner way	2
J 108	A	M93004021	ロッククアナツキホルト M3X5	Bolt M3X5	26
J 109		MB25A2477	Yジクストップ	Y-stopper	1
J 110		MB62E1957	Xジクイトウレース	X-movable race	1
J 111	A	MA20A4920	リアウエイ (X)	X-linear way	2
J 112		MB62E2477	Xジクストップ	X-stopper	2
J 113		M94001017	セフティソケット M4X10	Bolt M4X10	6
J 114		M95013021	ロッククアナツキホルト M3X10	Bolt M3X10	24
J 115		MB60A1429	ケンシュツハンササエ (R)	Bracket (right)	1
J 116		MB60A2601	ケンシュツハンソトリツケイタ	Bracket	2
J 117	A	MB62A1407	Xジクケンシュツハン	Detector plate X	1
J 118		MB25A1477	Yジクストップ (マエ)	Y-stopper (front)	1
J 119		MB60A0429	ケンシュツハンササエ (L)	Bracket (left)	1
J 120		M94008017	セフティソケット M4X6	Bolt M4X6	2
J 121		M90816004	SW-PWプラマイナヘネジ M3X8	Screw M3X8	4
J 125	A	MB62A0456	ベアリング 6000ZZNR	Bearing	2
J 126		MB45A0767	ベルトグルマ	Cog pulley	1
J 127		M96001001	ロッククアナツキメネジ M6X8	Screw M6X8	4
J 128		MB62A1454	Xクドウジク	X-drive shaft	1
J 129		MB61A0571	ジクツギテ	Coupling	2
J 130		M96002001	ロッククアナツキメネジ M6X6	Screw M6X6	8
J 131		M95044095	ステッピングモータクミタテ (X)	Motor complete (X)	1
J 132		M95004017	セフティソケット M5X16	Bolt M5X16	18
J 133		M90421050	ザガネ 4	Washer 4	4
J 134		MB62A0523	ハダカベルト (Xジク)	Cog belt (X)	1
J 135		MA35A1781	ベルトオサエ (X)	Belt clasper (X)	2
J 136		M90604065	Eガタメワ 8	E-type retaining ring 8	4
J 137		MA21P0454	ジク	Shaft	1
J 138		MB62A0767	ベルトグルマ	Cog pulley	1
J 139		MS02A2456	シールドボールベアリング	Ball bearing	6
J 140		MA35A6758	ブラケット	Bracket	1
J 141		M95015021	ロッククアナツキホルト M5X20	Bolt M5X20	1
J 142		MB62A1523	ハダカベルト (Yジク)	Cog belt (Y)	1
J 143		MB61A0767	ベルトグルマ	Cog pulley	1
J 144		M91071004	SW-MWプラマイナヘネジ M4X8	Screw M4X8	8
J 145		MB61A0758	ブラケット	Bracket	1
J 146		M95011021	ロッククアナツキホルト M5X25	Bolt M5X25	1
J 148		MB61A1758	ブラケット	Bracket	1
J 149		MB61A2767	ベルトグルマ	Cog pulley	1
J 150		MB61A1454	Yクドウジク	Y-drive shaft	1
J 152		M95043095	ステッピングモータクミタテ (Y)	Motor complete (Y)	1
J 153		M90511050	ザガネ 5	Washer 5	6
J 154		MS02A1454	ジク	Shaft	1

K 外押え機構(1)
WORK HOLDER MECHANISM(1)

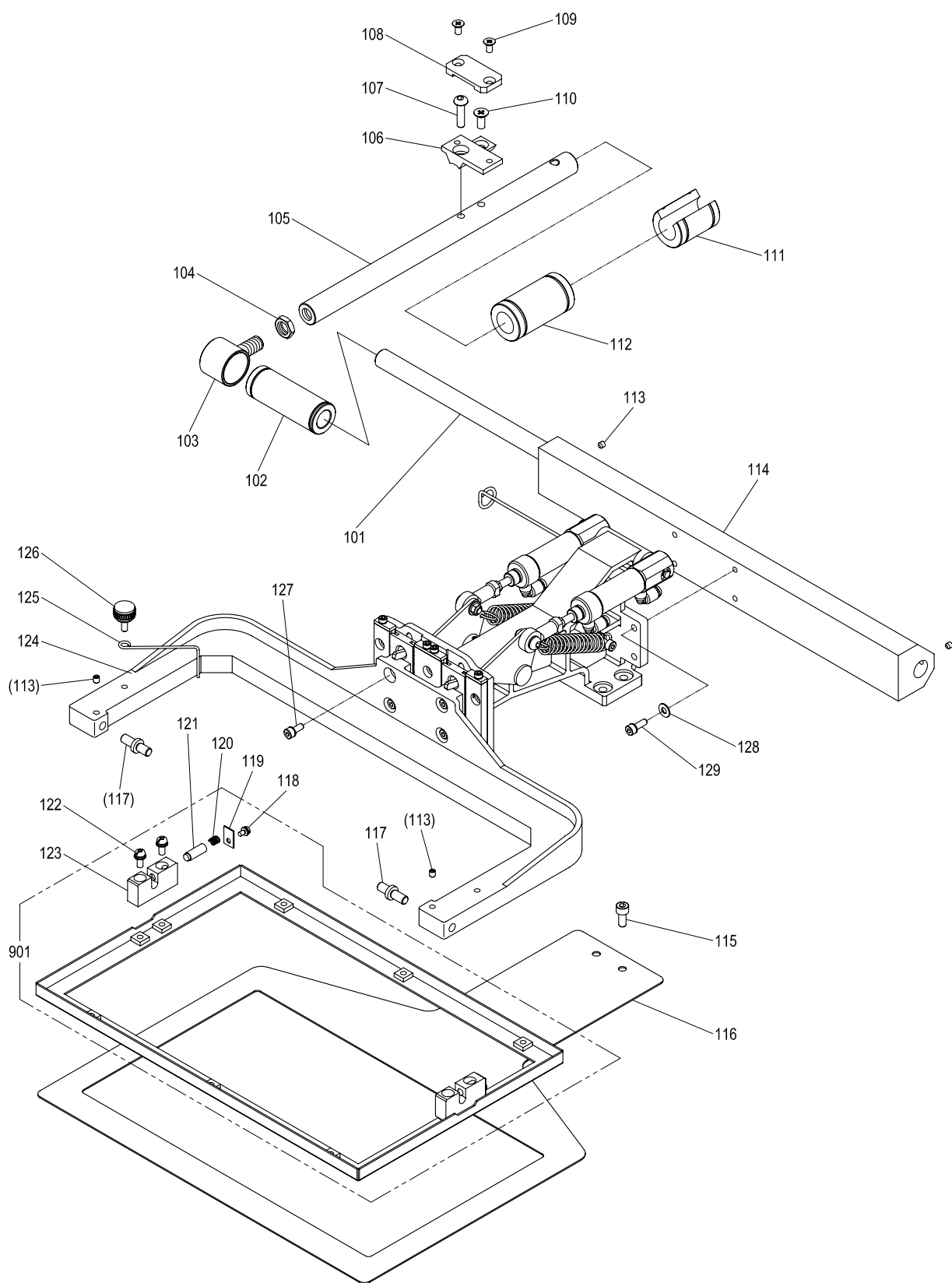

[K]外押え機構(1)

WORK HOLDER MECHANISM(1)

Fig no.	変更 Mod.	部品コード Parts no.	品名	Description	数量 Amt. Req.
K 101		MB62A2454	ジク	Shaft	1
K 102		MB62A0921	リニアブッシュ	Bearing	1
K 103		ME25A0692	ジクウケハウジング	Bearing housing	1
K 104		M92514045	ロックナット M10	Nut M10	1
K 105		ME25A0390	Yクトウジク	Y-drive shaft	1
K 106		ME25A0781	Yベルトダイ	Y-belt holder	1
K 107		M95031021	ロックアナツキボルト M5X12	Bolt M5X12	1
K 108		MS02A0778	ベルトオサエ	Belt clasper	1
K 109		M90448037	Pサラネジ M4X12	Screw M4X12	2
K 110		M90505037	Pサラネジ M5X12	Screw M5X12	1
K 111		ME25A0921	リニアブッシュ LM-16UU-OP	Bearing LM-16UU-OP	1
K 112		M96004070	リニアブッシュ LM-16UU	Bearing LM-16UU	1
K 113		M91053020	ロックアナツキメネジ M4X6	Screw M4X6	4
K 114		MB62A0455	ジクササエ	Shaft holder	1
K 115		M99002022	8Tロックホルト サラハネツキ M5X10	Bolt M5X10	2
K 116	A	MB62A2272	オクリイタ	Feed plate	1
K 117	A	ME40A0454	オサエジク	Clamp stud	2
K 118		M90859004	SW-PWプライネジ M3X6	Screw M3X6	2
K 119		MS02B0257	オサエイタ	Holder plate	2
K 120		MS13A0572	ツルマキバネ	Coil spring	2
K 121		M90611060	ピン	Pin	2
K 122		M91056004	SW-PWプライネジ M4X10	Screw M4X10	4
K 123	A	ME40A0426	ササエ	Support	2
K 124		MB62A0228	オサエウデ	Clamp adapter	1
K 125		MB61A2477	ストッパ	Stopper	1
K 126		MA20A0650	ナールノブ	Knurled knob	1
K 127		M95005017	セフティソケット M5X10	Bolt M5X10	4
K 128	A	M90421050	ワッシャ 4	Washer 4	4
K 129	A	M94006017	セフティソケット M4X16	Bolt M4X16	4
K 901		MB62E4105	ソトオサエミタテ	Clamp frame assy	1

L 外押え機構(2)
WORK HOLDER MECHANISM(2)

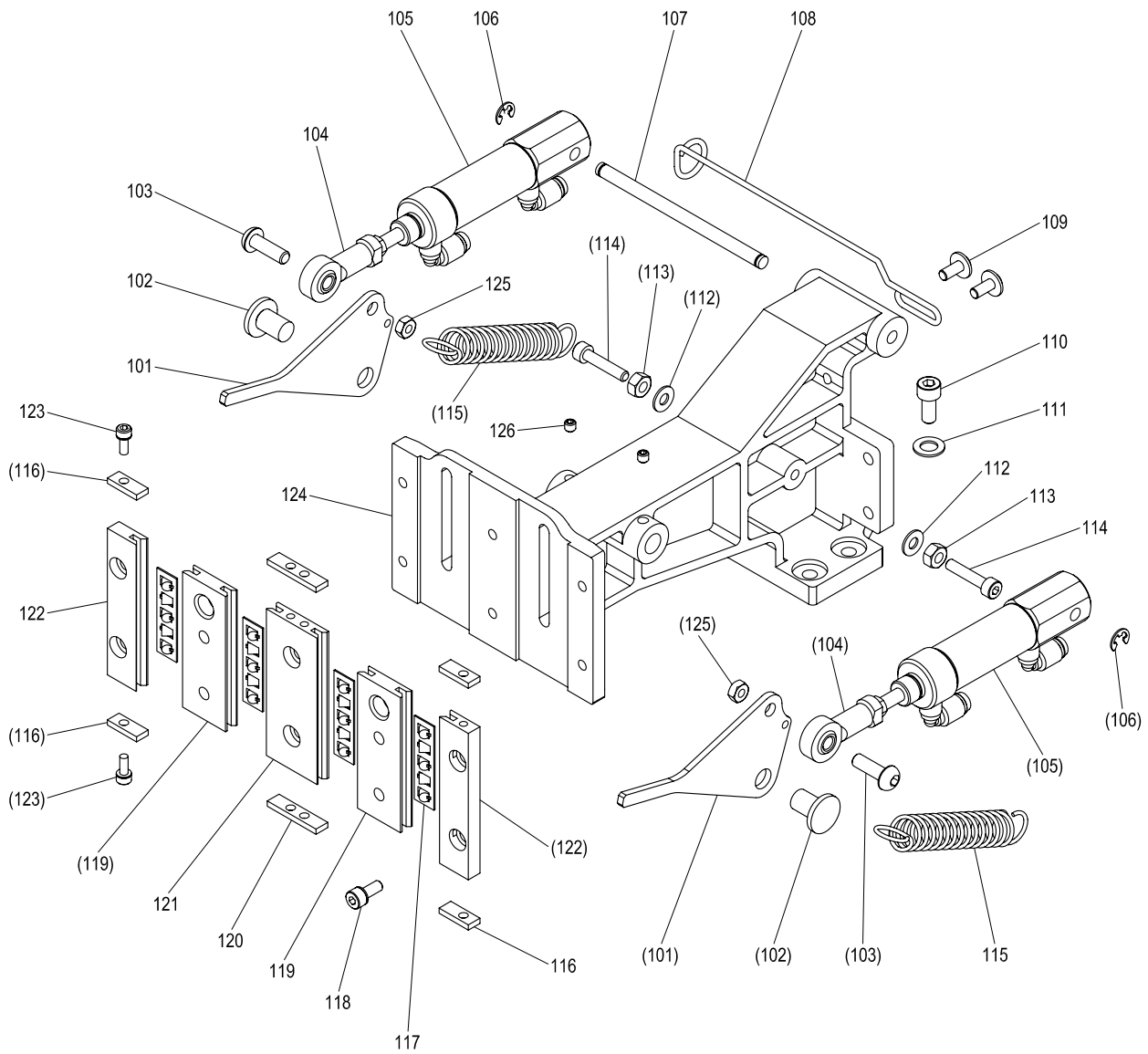

[L]外押え機構(2)

WORK HOLDER MECHANISM(2)

Fig no.	変更 Mod.	部品コード Parts no.	品名	Description	数量 Amt. Req.
L 101		MB62A0950	オサエレバー	Pushing lever	2
L 102		MB61A3454	ツハツキシク	Shaft	2
L 103		M95037021	ロックアナツキボルト M5X16	Bolt M5X16	2
L 104	A	MN55A0975	ロッドエンド	Connecting link	2
L 105		MB62A1434	エアシリンダ (ワンタッチツキテツキ)	Air cylinder (with quick joint)	2
L 106	A	M90504065	Eタイプメワ 4	E-type retaining ring 5	2
L 107		M90532060	ピン	Pin	1
L 108		MB62A0707	ハンガー	Hanger	1
L 109		M91013004	SW-MWプラマイナヘネジ M4X10	Screw M4X10	2
L 110	A	M95001017	セフティソケット M5X20	Bolt M5X20	4
L 111	A	M90511050	ワッシャー 5	Washer 5	4
L 112		M90421050	ワッシャー 4	Washer 4	2
L 113	A	M91007045	ナット M4	Nut M4	2
L 114		M94015021	ロックアナツキボルト M4X20	Screw M4X20	2
L 115		MB62A0572	ツルマキハネ	Spring	2
L 116		MB61A1477	ストッパ	Stopper	4
L 117		M94008070	ローラーリテーナ	Slide bearing	4
L 118		M94001017	セフティソケット M4X10	Bolt M4X10	6
L 119		MB62A1957	イトウレース	Movable race	2
L 120		MA22A0477	ストッパ	Stopper	2
L 121		MA22A2957	コテイレース	Fixed race	1
L 122		MB62A0957	コテイレース	Fixed race	2
L 123		M94012017	セフティソケット M3X8	Bolt M3X8	8
L 124		MB62A0263	オサエタイ	Clamp bracket	1
L 125		M91382045	ナット M5	Nut M5	2
L 126		M91055020	ロックアナツキメネジ M4X4	Screw M4X4	2

M ワイパー機構
WIPER MECHANISM

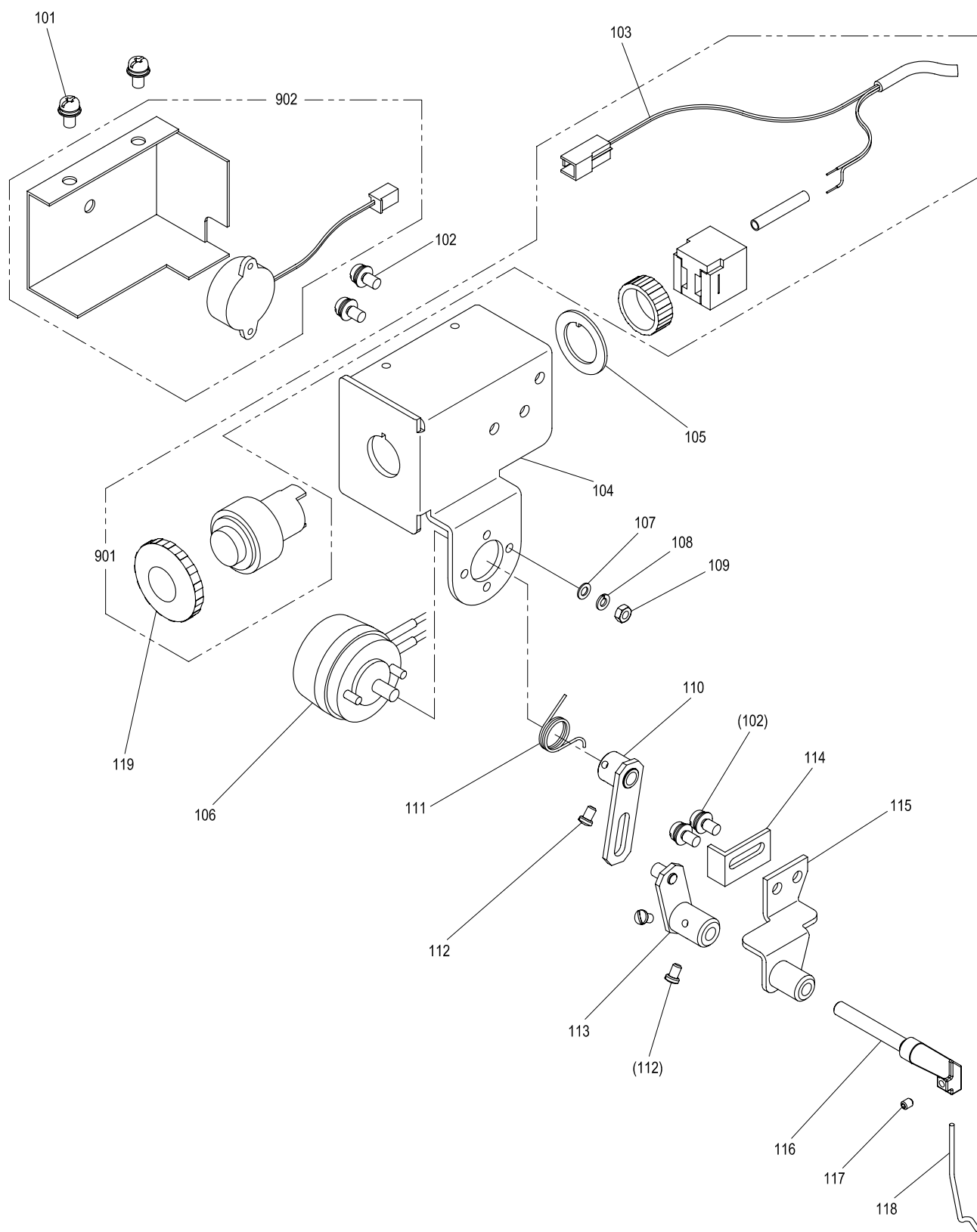

[M]ワイパー機構
WIPER MECHANISM

Fig no.	変更 Mod.	部品コード Parts no.	品名	Description	数量 Amt. Req.
M 101	A	M91054004	SW-PW ^ラ マイナ ^ベ ネジ [°] M4X8	Screw M4X8	2
M 102	A	M91056004	SW-PW ^ラ マイナ ^ベ ネジ [°] M4X10	Screw M4X10	4
M 103		M97356099	セツク ^テ ンセン	Cable (stop BZ)	1
M 104		ME10E3601	トリツケ ^イ タ	Bracket	1
M 105		MB60A0915	ロック ^リ ング	Lock ring	1
M 106		MB61E1519	ワイパ ^ー ソレノ ^イ ド	Solenoid (wiper)	1
M 107		M90317050	サガ ^ネ 3	Washer 3	2
M 108		M90307053	バネサガ ^ネ 3	Spring washer 3	2
M 109		M90875045	ナツ M3	Nut M3	2
M 110		MS02E0983	ク ^ト ウ ^イ タ	Wiper crank	1
M 111		MS02A4729	ヒネ ^リ ハ ^ネ	Spring	1
M 112		M90802003	マルヒ ^ラ ネジ [°] 1/8(44)X4.5	Screw 1/8(44)x4.5	4
M 113		MB61A0436	シュウ ^ト ウ ^イ タ	Wiper crank	1
M 114		MS02A1477	ストッ ^パ	Stopper	1
M 115		MS10A0982	ワイパ ^ー ダ ^イ	Wipper adapter	1
M 116		MB61E0982	ワイパ ^ー ジ ^ク	Wiper shaft	1
M 117		M91057020	ロック ^ク ア ^ナ ツ ^キ ト ^メ ネジ [°] M3X4	Screw M3X4	1
M 118		MA20A0980	ワイパ ^ー	Wiper	1
M 119	A	ME03A0270	プッ ^シ ュ ^ホ タ ^ン	Push button	1
M 901		ME10E0270	オン ^ホ タ ^ン ス ^イ ツ ^チ ク ^ミ	Switch assy	1
M 902		MB60E3339	カバ ^ー ク ^ミ (ブ ^ザ ー ^ツ キ)	Cover assy (with buzzer)	1

N 給油機構

OIL LUBRICATION MECHANISM

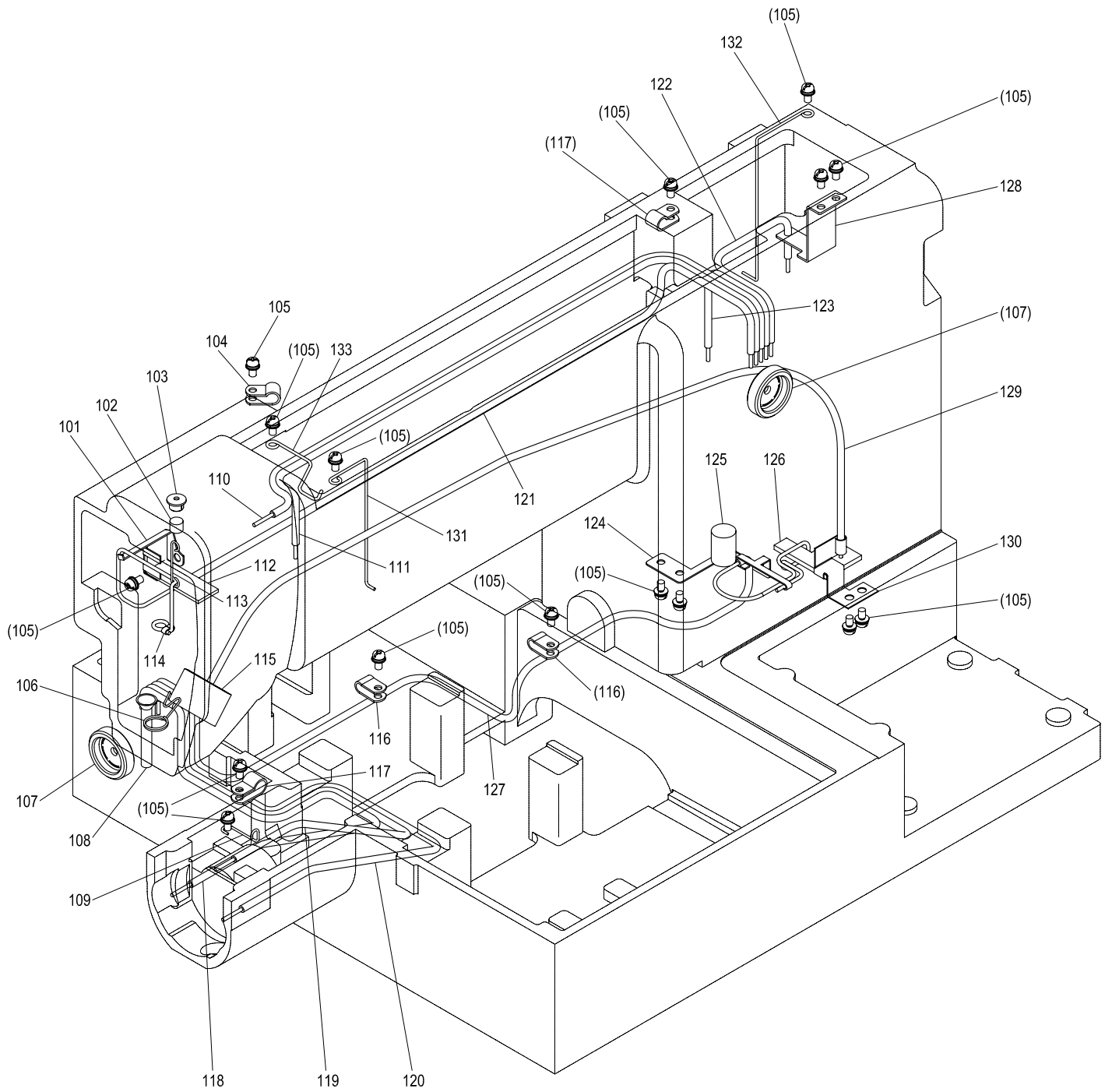

[N]給油機構

OIL LUBRICATION MECHANISM

Fig no.	変更 Mod.	部品コード Parts no.	品名	Description	数量 Amt. Req.
N 101		ME10A1780	ホルダ	Holder	1
N 102		MF10A2740	フェルト	Felt	1
N 103		MF60A0742	フタ	Cap	1
N 104	A	MS14A1620	ナイロンクリップ AB-4N	Nylon clip AB-4N	1
N 105		M91054004	SW-PWプラマイナネジ M4X8	Screw M4X8	16
N 106		MF00A2780	ホルダ	Holder	1
N 107		MN10A0135	オイルゲージ	Oil gauge	2
N 109		MS01A8796	ホルダ	Holder	1
N 110		MB62E3148	パイプヒモクミ (ウワジクメタル マE)	Oil pipe assy (drive shaft bushing F)	1
N 111		MB60E2148	パイプヒモクミ (ヘンシンリン)	Oil pipe assy (eccentric cam)	1
N 112		MS01A1740	フェルト	Felt	1
N 113		MS03A2780	ホルダ	Holder	1
N 114		MF80A0780	ホルダ	Holder	1
N 115		MS01A0740	フェルト	Felt	1
N 116		M94003099	ナイロンクリップ AB-3N	Nylon clip AB-3N	2
N 117		MN60A0620	ナイロンクリップ AB-5N	Nylon clip AB-5N	2
N 118		ME25E0688	パイプヒモクミ (カマ ヒタリ)	Oil pipe assy (hook left)	1
N 119		MB62E4148	パイプヒモクミ (カマ ナカ)	Oil pipe assy (hook center)	1
N 120		ME25E1688	パイプヒモクミ (カマ ミキ)	Oil pipe assy (hook right)	1
N 121		MB62E1148	パイプヒモクミ (ハリホウ)	Oil pipe assy (needle bar)	1
N 122		ME03E5688	パイプヒモクミ (レンセツカン)	Oil pipe assy (connecting rod)	1
N 123		MA20E3688	パイプヒモクミ (ウワジクメタル ナカ)	Oil pipe assy (drive shaft bushing C)	1
N 124		MS14A3780	ホルダ	Holder	1
N 125		MF60A5740	フェルト	Felt	1
N 126		MS14A0740	フェルト	Felt	1
N 127	A	ME25E3688	パイプヒモクミ (シタジクメタル ウシロ)	Oil pipe assy (hook shaft bushing R)	1
N 128		MB60A1780	ホルダ	Holder	1
N 129		MB62E0148	パイプヒモクミ (カンユ)	Oil pipe assy (circulation)	1
N 130		MS01A9796	ホルダ	Holder	1
N 131	A	MS10A0780	ホルダ	Holder	1
N 132	A	ME20A1780	ホルダ	Holder	1
N 133	A	MA20A1780	ホルダ	Holder	1

P 配線配管関係
CABLE COMPONENT & PNEUMATIC CONTROL UNIT

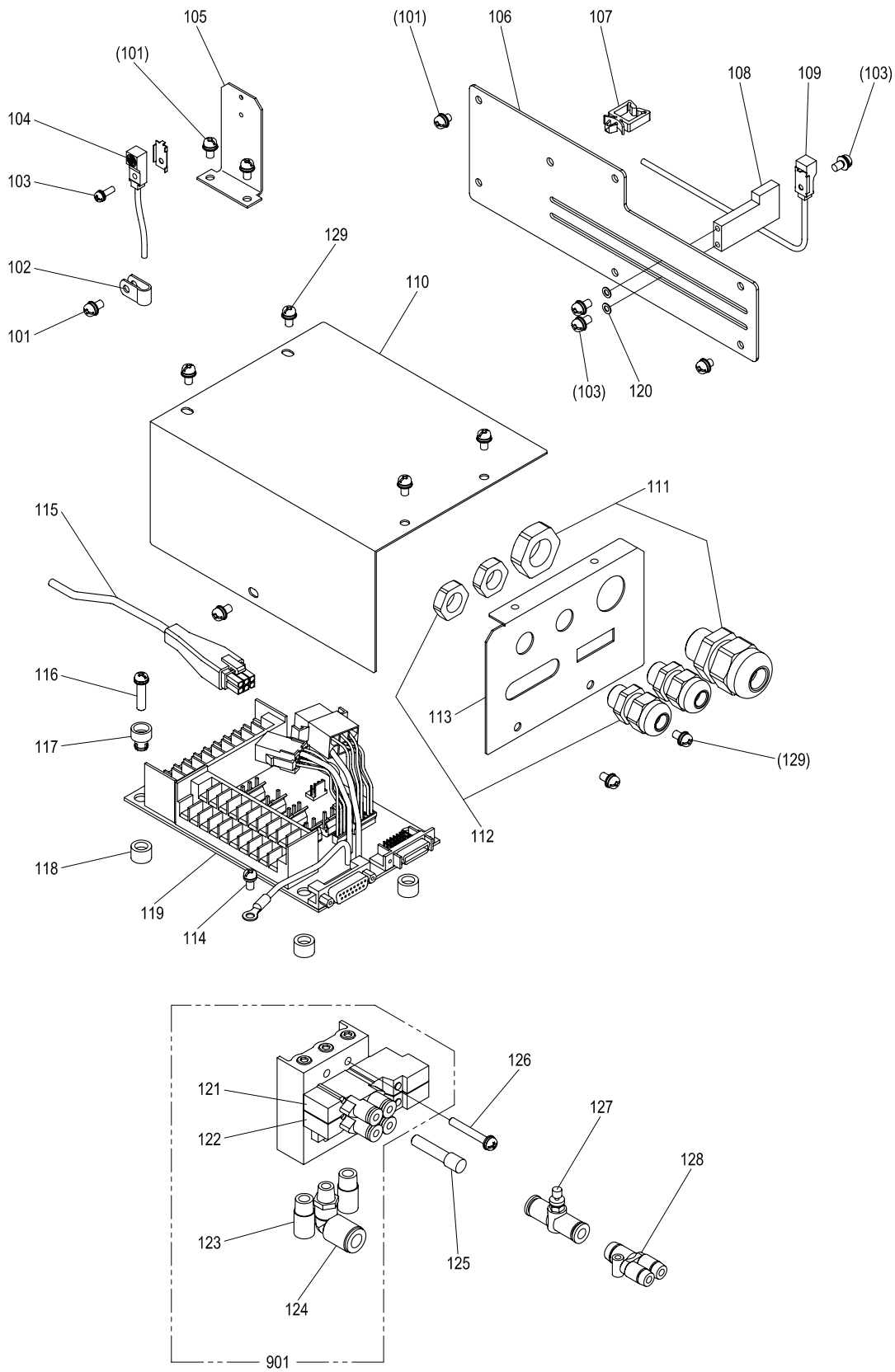

[P]配線・配管関係

CABLE COMPONENT & PNEUMATIC CONTROL UNIT

Fig no.	変更 Mod.	部品コード Parts no.	品名	Description	数量 Amt. Req.
P 101		M91054004	SW-PWフライナネジ M4X8	Screw M4X8	12
P 102		M94003099	ナイロンクリップ AB-3N	Nylon clip AB-3N	4
P 103		M90971004	SW-PWフライナネジ M3X10	Screw M3X10	4
P 104	A	ME25A1484	キンセツスイッチ X	Detector X	1
P 105		ME10A0408	ケンシュツダイ X	Detector bracket X	1
P 106	A	ME25A2339	カバー	Cover	1
P 107		ME25A0389	ケーブルクランプ	Cable clamp	1
P 108		ME25A0408	ケンシュツダイ Y	Detector bracket Y	1
P 109		ME25A0484	キンセツスイッチ Y	Detector Y	1
P 110		MB60A5339	Pハンカバー	Circuit board cover	1
P 111		MB60A5780	コードフツシュ 大	Cord bushing (large)	1
P 112		MB60A6780	コードフツシュ ショウ	Cord bushing (small)	2
P 113		MB60A5601	コネクタ外リツケイタ	Connector panel	1
P 114	A	M90439037	SWフライナネジ M4X8	Screw M4X8	1
P 115		K14M71725402	ケーブル (エンコーダ)	Cable (encoder)	1
P 116		M91057004	SW-PWフライナネジ M4X20	Screw M4X20	4
P 117		MB60A0366	ワンタッチフツシュ	Nylon bush	4
P 118		MB60A2352	ワンタッチフツシュ	Nylon bush	4
P 119	B	M800E2CON	Pハンクミタテ	Print circuit board	1
P 120	A	M90316050	サガネ 3	Washer 3	2
P 121		MB62A1599	デンジベン (ナカオサエ)	Solenoid valve (presser bar lifting)	1
P 122		MB62A2599	デンジベン (ソトオサエ)	Solenoid valve (work holder)	1
P 123		M91035089	サイレンサ AN101-01	Muffler	2
P 124		MA20A8571	Lガタツギテ KQL08-01S	L-type quick joint	1
P 125		MB62A0757	プラグ	Plug	1
P 126	A	M91276004	SW-PWフライナネジ M4X30	Screw M4X30	4
P 127	A	MA16A0495	スピードコントローラ AS1001-F06	Speed controller	1
P 128		MA20A6571	イケイユニオン Y KJU04-06	Y-type quick joint	1
P 129	A	M91071004	SW-PWフライナネジ M4X8	Screw M4X8	7
P 901		MB62E0599	デンジベンクミタテ	Solenoid valve assy	1

Q テーブル関係
TABLE & STAND

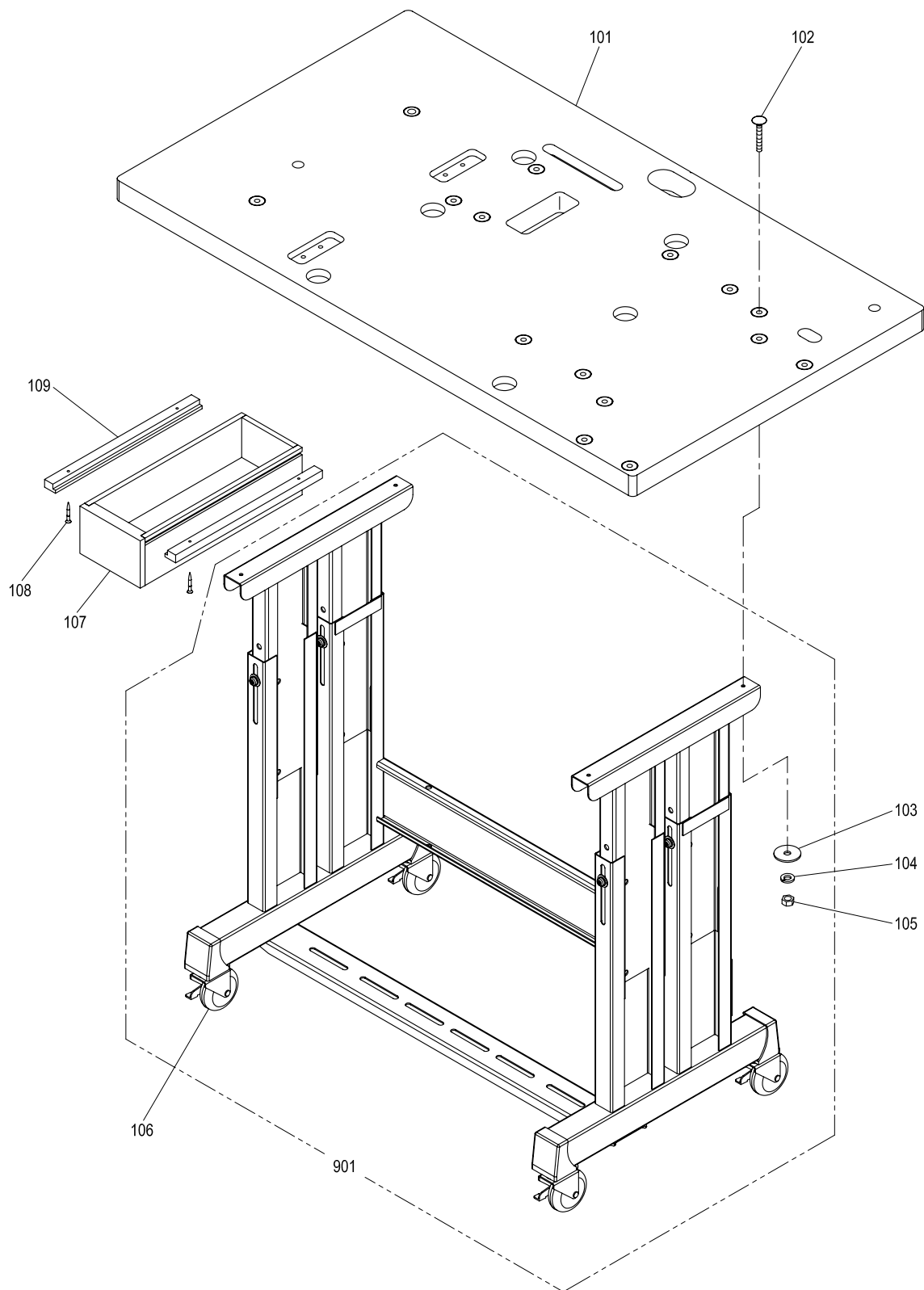

[Q]テーブル関係
TABLE & STAND

Fig no.	変更 Mod.	部品コード Parts no.	品 名	Description	数量 Amt. Req.
Q 101		MB62A0595	テシイタ	Table top	1
Q 102		K14M90451403	トリツケホルト M8X70	Mounting bolt M8X70	4
Q 103	A	M90710050	トクシユサガネ 8	Special washer 8	4
Q 104	A	M90802053	ハネサガネ 8	Spring washer 8	4
Q 105	A	M92008045	ナツト M8	Nut M8	4
Q 106	B	MB60A1368	キャスト	Caster	4
Q 107		MB60A0719	ヒキタシ	Drawer	1
Q 108		M90406040	Pサラモクネジ φ4.5X38	Wooden screw φ4.5X38	4
Q 109	A	MB60A3957	レール	Rail	2
Q 901		MB60E0150	キヤククミタテ	Leg assy	1

R 付属品(1)
ACCESSORIES(1)

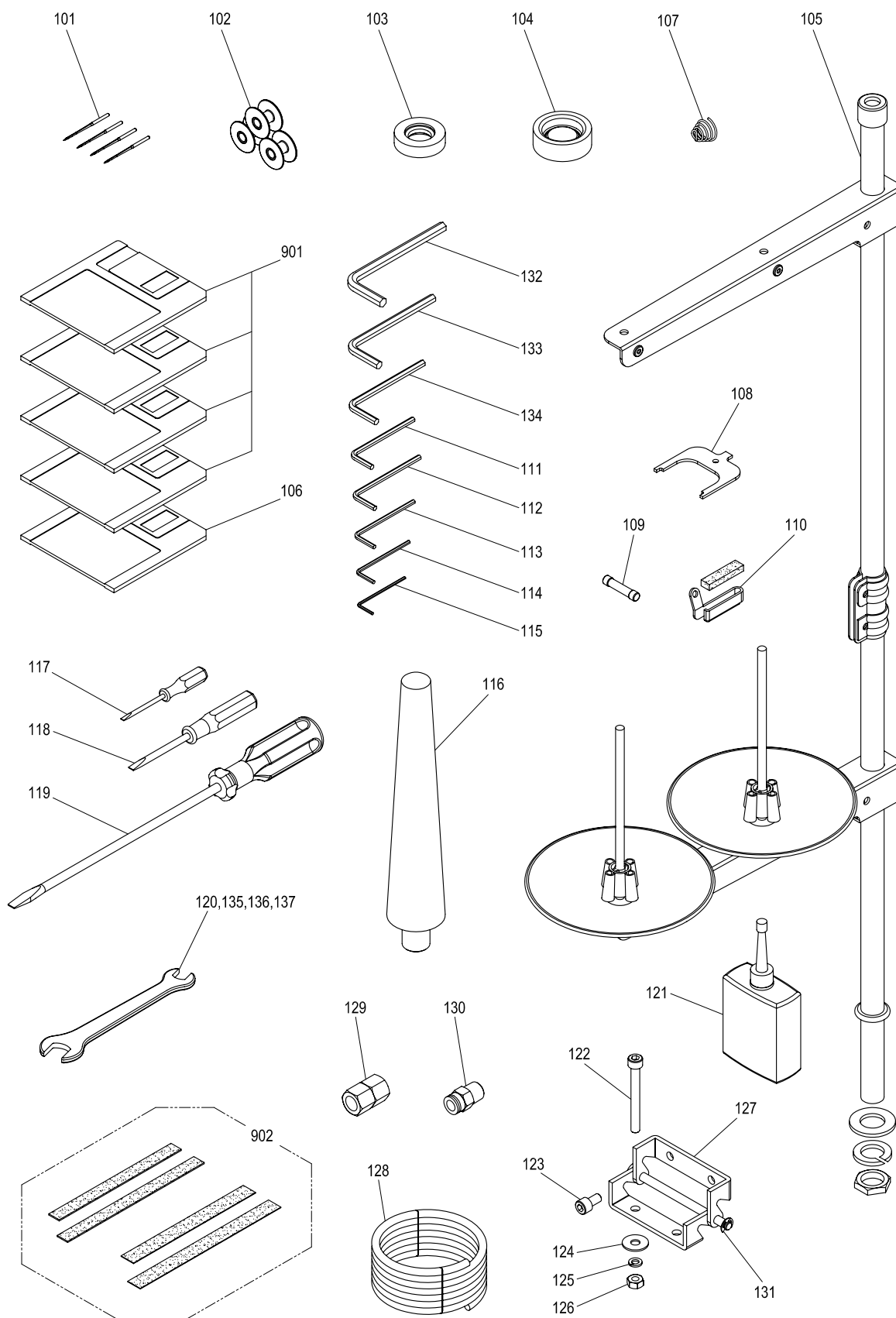

[R] 付属品(1)
ACCESSORIES(1)

Fig no.	変更 Mod.	部品コード Parts no.	品名	Description	数量 Amt. Req.
R 101		MS02A0128	ミシンハリ DPX17#18	Needle DPX17#18	4
R 102		MA10A0123	ホビン	Bobbin	3
R 103		MS03A0417	ゴムワ (イトマキヨウ)	Tire (for bobbin winder)	1
R 104		MB60A0419	ホウシンゴム	Rubber cushion	6
R 105		MF40E0193	イトタテアイクミタテ	Cotton stand assy	1
R 106		MB60A1990	データフロッピーディスク	Pattern data F/D	1
R 107	A	MN52A1245	エンスライバネ	Tension spring	1
R 108		MF01A0565	カドチョウセイグ	Speed command disk adjusting plate	1
R 109		M82510FUS	ヒューズ	Fuse	2
R 110		MS03A0181	イトアンナイ	Thread guide	1
R 111		MS01A1976	ロッカクホウレンチ 4	Hexagonal wrench 4	1
R 112	A	MS02A2976	ロッカクホウレンチ 3	Hexagonal wrench 3	1
R 113	A	MS02A1976	ロッカクホウレンチ 2.5	Hexagonal wrench 2.5	1
R 114	A	MS02A0976	ロッカクホウレンチ 2	Hexagonal wrench 2	1
R 115	A	MS10A0976	ロッカクホウレンチ 1.5	Hexagonal wrench 1.5	1
R 116		MA20A0613	トウフササエ	Head rest	1
R 117		MB02A1608	ドライバ (ショウ)	Screw driver (small)	1
R 118		MB02A0608	ドライバ (チュウ)	Screw driver (middle)	1
R 119		MF00A0608	ドライバ (ダイ)	Screw driver (large)	1
R 120		MM10A1479	スパナ 10-14	Spanner 10-14	1
R 121		MF10A0149	アブラサシ	Oiler with oil	1
R 122		M96020021	ロッカクアナツキボルト M6X55	Bolt M6x55	4
R 123		M96002017	セフティソケット M6X12	Bolt M6x12	4
R 124		M90630050	ワッシャ 6.5-18	Washer 6.5-18	4
R 125		M90624053	バネサガネ 6	Spring washer 6	4
R 126		M91576045	ナット M6	Nut M6	4
R 127		MB60A0560	チョウバン	Hinge	2
R 128	A	MS06A0567	エアチューブ	Air tube	1
R 129	A	M91010089	ロッカクソケット YST-2ガタ NP-202	Socket	1
R 130		MA30A0571	ワンタッチツギテ KQH08-02S	Quick joint	1
R 131	A	M90809065	Eタイプメワ 5	E-type retaining ring 5	1
R 132	A	MS05A1976	ロッカクホウレンチ 6	Hexagonal wrench 6	1
R 133	A	MS05A0976	ロッカクホウレンチ 5	Hexagonal wrench 5	1
R 134	A	MF90A0976	ロッカクホウレンチ 1/8"	Hexagonal wrench 1/8"	1
R 135	A	MS02A0479	スパナ 13-17	Spanner 13-17	1
R 136	A	MS10A1976	スパナ 8-9	Spanner 8-9	1
R 137	A	MS10A2976	スパナ 6-7	Spanner 6-7	1
R 901	A	ME20E0990	システムフロッピーディスク (4マイ)	System F/D (4discs)	1
R 902		ME25E0691	パッキンセット	Clamp pad set	1

S 付属品(2)
ACCESSORIES(2)

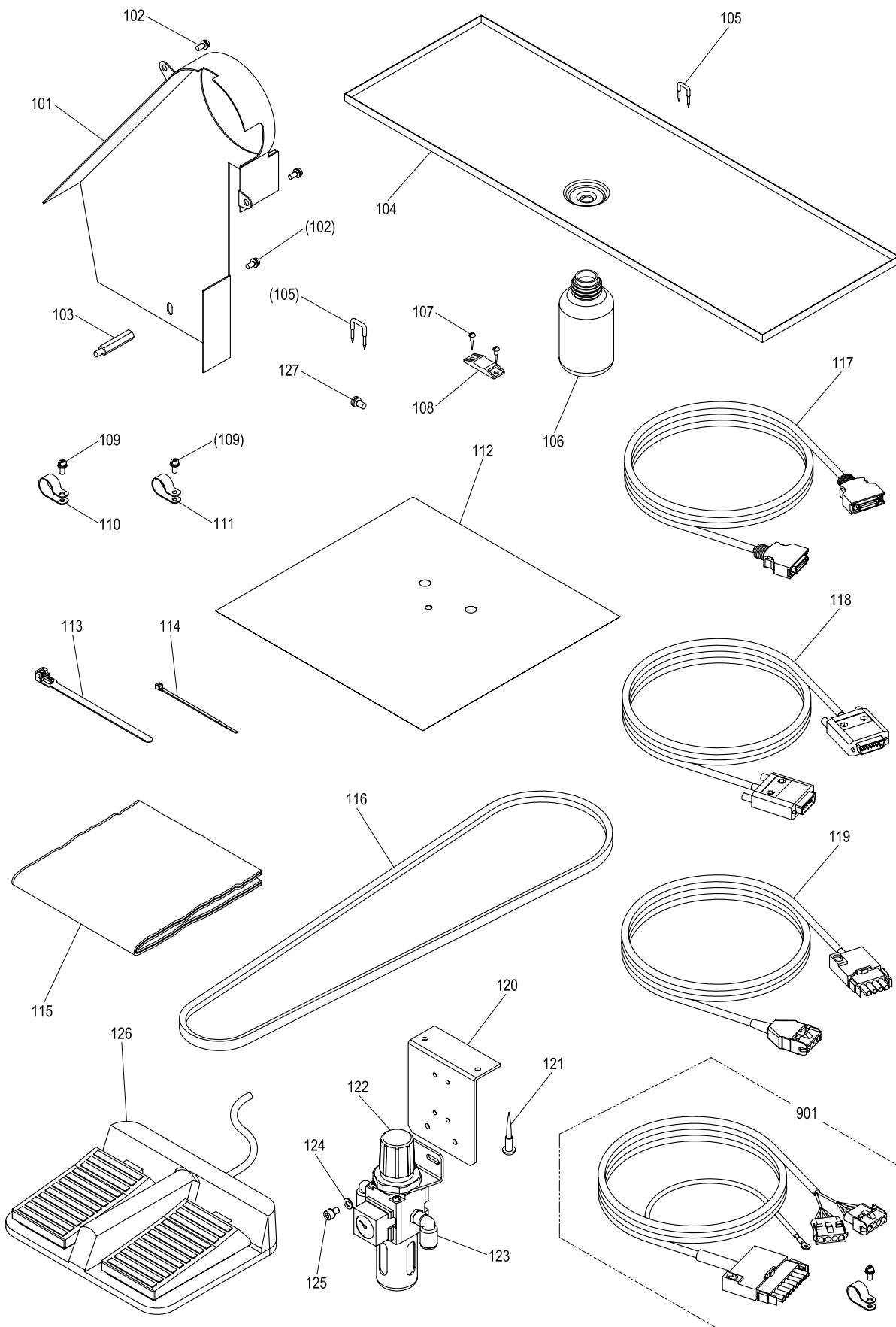

[S]付属品(2)
ACCESSORIES(2)

Fig no.	変更 Mod.	部品コード Parts no.	品名	Description	数量 Amt. Req.
S 101		MB62E0776	ベルトカバー	Belt cover	1
S 102		M91067004	SW-PWネジ M5X10	Screw M5X10	3
S 103		M95001031	トクショボルト M5	Special bolt M5	1
S 104		MB62E0131	アブラウケ	Oil pan	1
S 105	A	M90001043	ステッフル	Staple	7
S 106		MF20A0130	アブラビン	Oil bottle	1
S 107		M90306041	マルモクネジ 3.1X16	Wood screw 3.1x16	4
S 108		MB60A0420	コタイゲ	Tie holder	2
S 109		M91056004	SW-PWネジ M4X10	Screw M4X10	2
S 110		MB60A2620	ナイロンクリップ AB-10N	Nylon clip AB-10N	1
S 111		MB60A1620	ナイロンクリップ AB-8N	Nylon clip AB-8N	1
S 112		MB63A0797	ホゴフィルム	Film sheet	1
S 113		MB60A0201	ハインダー	Cord tie	2
S 114		MG51A0201	ハインダー	Cord tie	1
S 115	A	MA20A0734	ビニルカバー	Polyethylene cover	1
S 116		MB62A0777	Vベルト M46	V-belt M46	1
S 117		M97319099	ケーブル (ニューリヨクシンコウ)	Cable (input signal)	1
S 118		M97320099	ケーブル (ソレノイド)	Cable (solenoid)	1
S 119		M97318099	ケーブル (サーボモータデンゲン)	Cable (servo motor)	1
S 120		MB61A5601	レギュレータリツケイタ	Filter regulator adapter	1
S 121		M90409041	マルモクネジ 4.5X20	Screw 4.5X20	2
S 122	A	MB61A0963	フィルタレギュレータ (ステーツキ)	Filter regulator	1
S 123		MA20A8571	Lカタツキテ KQL08-01S	L-type quick joint	2
S 124		M90511050	ザガネ 5	Washer 5	2
S 125	A	M95003017	セフティソケット M5X8	Bolt M5X8	2
S 126		M860A0FSW	フットスイッチ	Foot switch	1
S 127	A	M90439037	SWネジ M4X8	Screw M4X8	1
S 901	A	M97321099	ケーブル (パルスモータ)	Cable (pulse motor)	1

T オプションパーツ
OPTION PARTS

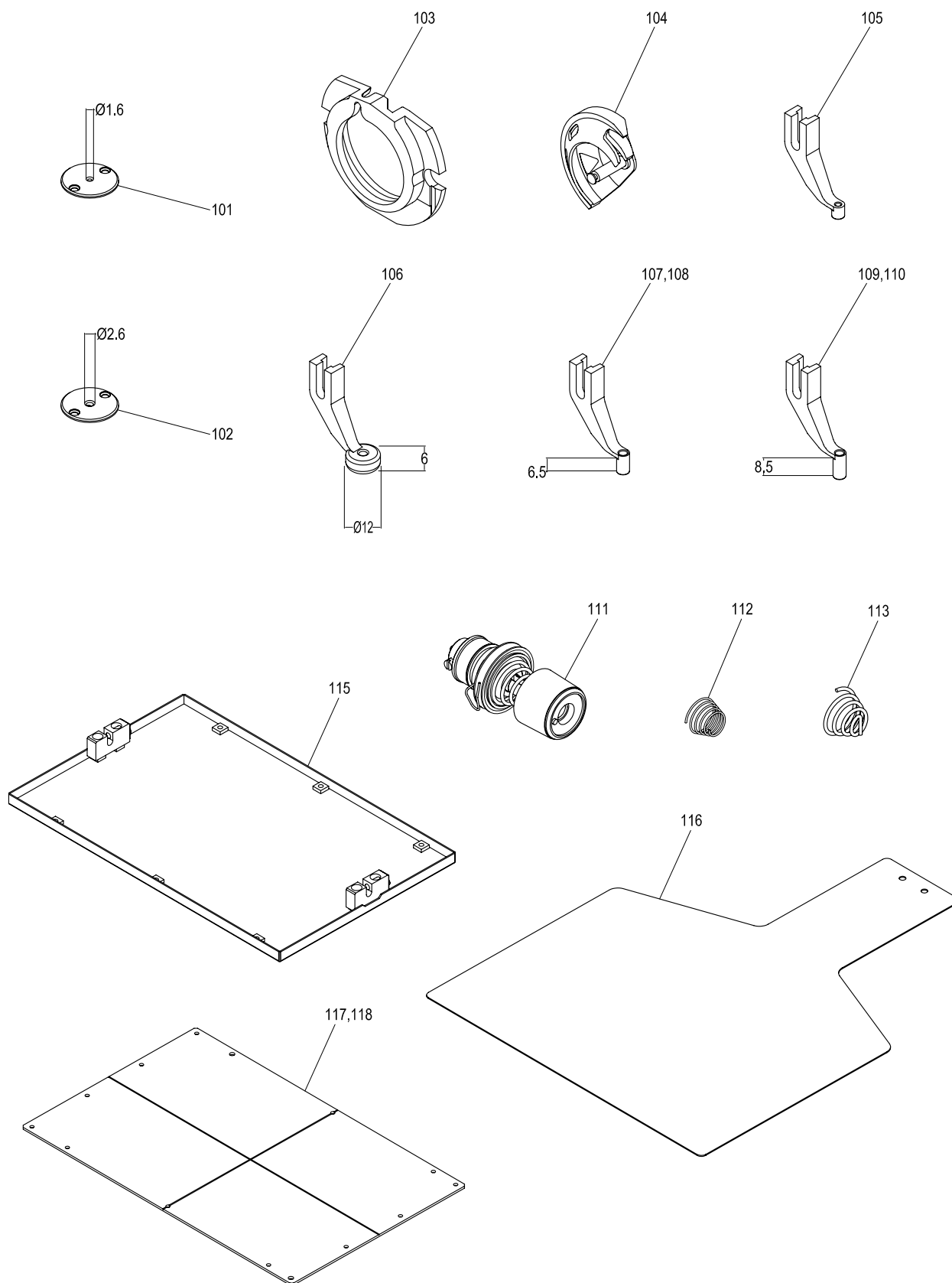

[T]オプションパーツ
OPTION PARTS

Fig no.	変更 Mod.	部品コード Parts no.	品名	Description	数量 Amt. Req.
T 101		MS03A0101	ハリイタ (ウスモ/ヨウ) φ1.6	Needle plate (for light) φ1.6	1
T 102		MS03A2101	ハリイタ (アツモ/ヨウ) φ2.6	Needle plate (for heavy) φ2.6	1
T 103		MS01A1616	ナカガマオサエ (アツモ/ヨウ)	Inner hook clamber (for heavy)	1
T 104		MS17A1120	ナカガマ (アツモ/ヨウ)	Inner hook (for heavy)	1
T 105		MV30A1256	ナカオサエ (ウスモ/ヨウ)	Presser foot (for light)	1
T 106		MV35A0106	サラオサエ φ3	Presser foot φ3	1
T 107		MS03A0256	ナカオサエ φ3	Presser foot φ3	1
T 108		MS03A1256	ナカオサエ φ2	Presser foot φ2	1
T 109		MA35A0256	ナカオサエ φ3	Presser foot φ3	1
T 110		MA35A1256	ナカオサエ φ2	Presser foot φ2	1
T 111		MS04E1210	ウワイトチョウセツキ (クミ)	Thread tension regulator assy	1
T 112		MF10A1245	エンスイハネ (プリテンションヨウ)	Spring (for pretension)	1
T 113		MN10A3245	エンスイハネ (ウワイトチョウセツキヨウ)	Spring (for thread tension regulator)	1
T 115		MB62E3105	ソトオサエクミタテ (アナナシ)	Clamp frame assy (blank)	1
T 116		MB62A0272	シタオサエイタ (アナナシ)	Feed plate (blank)	1
T 117		MB62A0762	ナカオサエイタ (2T, ケガキセンアリ)	Clamp plate (with line)	1
T 118		MB62A1762	ナカオサエイタ (2T, ケガキセンナシ)	Clamp plate	1

索引
INDEX-1

部品コード Parts No.	ページ Page	Fig No.	部品コード Parts No.	ページ Page	Fig No.	部品コード Parts No.	ページ Page	Fig No.	部品コード Parts No.	ページ Page	Fig No.
K14M71725402	*** P27	*** P 115	M90806002	*** P3	*** B 129	M91058004	*** P7	*** D 101	M93001050	*** P9	*** E 106
K14M90451403	*** P29	*** Q 102	M90809065	*** P31	*** R 131	M91058020	*** P13	*** G 113	M93004021	*** P17	*** J 108
M800E2CON	*** P27	*** P 119	M90814004	*** P17	*** J 102	M91059004	*** P9	*** E 103	M93023050	*** P11	*** F 130
M82510FUS	*** P31	*** R 109	M90815002	*** P9	*** E 130	M91066004	*** P3	*** B 136	M93202047	*** P13	*** G 131
M860A0FSW	*** P33	*** S 126	M90816004	*** P17	*** J 121	M91067004	*** P33	*** S 102	M93220035	*** P13	*** G 130
M90001043	*** P33	*** S 105	M90823050	*** P3	*** B 109	M91071004	*** P27	*** P 129	M94001017	*** P17	*** J 113
M90001060	*** P11	*** F 128	M90825002	*** P15	*** H 102	↑	*** P17	*** J 144	↑	*** P3	*** B 121
M90101017	*** P15	*** H 152	M90853002	*** P11	*** F 126	↑	*** P3	*** B 138	↑	*** P21	*** L 118
M90104036	*** P7	*** D 108	M90859004	*** P7	*** D 104	M91101017	*** P15	*** H 138	M94003099	*** P25	*** N 116
M90204060	*** P5	*** C 163	↑	*** P3	*** B 123	M91101046	*** P5	*** C 149	↑	*** P27	*** P 102
M90306041	*** P33	*** S 107	↑	*** P19	*** K 118	M91102045	*** P15	*** H 164	M94006017	*** P19	*** K 129
M90307053	*** P23	*** M 108	M90875045	*** P23	*** M 109	M91104045	*** P15	*** H 150	M94008017	*** P17	*** J 120
M90316050	*** P27	*** P 120	M90883080	*** P3	*** B 137	M91108001	*** P15	*** H 162	M94008070	*** P21	*** L 117
M90317050	*** P23	*** M 107	M90901002	*** P5	*** C 162	M91109045	*** P15	*** H 158	M94012017	*** P21	*** L 123
↑	*** P17	*** J 101	M90906003	*** P15	*** H 127	M91110002	*** P3	*** B 127	M94015021	*** P21	*** L 114
M90325065	*** P13	*** G 128	↑	*** P3	*** B 120	M91112002	*** P15	*** H 106	M95001017	*** P21	*** L 110
M90330065	*** P9	*** E 105	M90909003	*** P3	*** B 125	M91119002	*** P9	*** E 142	M95001021	*** P11	*** F 123
M90406040	*** P29	*** Q 108	↑	*** P13	*** G 115	M91127015	*** P15	*** H 101	M95001031	*** P33	*** S 103
M90406064	*** P9	*** E 140	M90920002	*** P5	*** C 108	M91129015	*** P15	*** H 130	M95002001	*** P11	*** F 104
M90409041	*** P33	*** S 121	M90922002	*** P13	*** G 139	M91131002	*** P13	*** G 146	M95002017	*** P3	*** B 118
M90421050	*** P17	*** J 133	M90939002	*** P5	*** C 109	M91182080	*** P3	*** B 135	↑	*** P17	*** J 106
↑	*** P19	*** K 128	M90971004	*** P27	*** P 103	M91203002	*** P11	*** F 101	↑	*** P15	*** H 161
↑	*** P21	*** L 112	M90990002	*** P9	*** E 136	M91214015	*** P15	*** H 133	M95003001	*** P9	*** E 122
↑	*** P3	*** B 139	↑	*** P7	*** D 113	M91219015	*** P13	*** G 147	↑	*** P11	*** F 133
↑	*** P9	*** E 102	↑	*** P3	*** B 114	M91221001	*** P9	*** E 144	M95003017	*** P13	*** G 150
M90422050	*** P15	*** H 109	↑	*** P15	*** H 119	M91224001	*** P15	*** H 131	↑	*** P33	*** S 125
M90423060	*** P13	*** G 145	M91004067	*** P5	*** C 120	M91276004	*** P5	*** C 102	M95003021	*** P15	*** H 141
M90424053	*** P15	*** H 108	M91005067	*** P5	*** C 122	↑	*** P27	*** P 126	M95004017	*** P17	*** J 132
M90439037	*** P27	*** P 114	M91007045	*** P21	*** L 113	M91382045	*** P15	*** H 112	M95004020	*** P13	*** G 156
↑	*** P33	*** S 127	↑	*** P15	*** H 107	↑	*** P21	*** L 125	↑	*** P5	*** C 160
M90448037	*** P19	*** K 109	M91010089	*** P31	*** R 129	M91503001	*** P11	*** F 111	M95004021	*** P11	*** F 107
M90500085	*** P11	*** F 115	M91011004	*** P5	*** C 144	M91504031	*** P13	*** G 144	↑	*** P15	*** H 151
M90504065	*** P21	*** L 106	M91013004	*** P21	*** L 109	M91506001	*** P13	*** G 136	M95005017	*** P15	*** H 111
M90505037	*** P19	*** K 110	↑	*** P5	*** C 103	M91520002	*** P9	*** E 112	↑	*** P19	*** K 127
M90511050	*** P21	*** L 111	M91035089	*** P27	*** P 123	M91551015	*** P13	*** G 125	M95006017	*** P13	*** G 154
↑	*** P15	*** H 160	M91053020	*** P9	*** E 120	M91572045	*** P13	*** G 122	M95006020	*** P9	*** E 143
↑	*** P33	*** S 124	↑	*** P19	*** K 113	M91576045	*** P15	*** H 145	M95011021	*** P17	*** J 146
↑	*** P17	*** J 153	↑	*** P5	*** C 142	↑	*** P31	*** R 126	M95013021	*** P17	*** J 114
↑	*** P3	*** B 117	M91054004	*** P23	*** M 101	M91602001	*** P9	*** E 118	M95015021	*** P17	*** J 141
M90512050	*** P17	*** J 105	↑	*** P25	*** N 105	M91602046	*** P5	*** C 117	M95031021	*** P19	*** K 107
M90513065	*** P15	*** H 136	↑	*** P27	*** P 101	M91603003	*** P13	*** G 121	M95037021	*** P21	*** L 103
M90532060	*** P21	*** L 107	↑	*** P3	*** B 103	M91606001	*** P9	*** E 133	M95043095	*** P17	*** J 152
M90601064	*** P5	*** C 123	↑	*** P15	*** H 118	↑	*** P13	*** G 129	M95044095	*** P17	*** J 131
M90604065	*** P17	*** J 136	↑	*** P5	*** C 140	M91610046	*** P5	*** C 155	M95051021	*** P15	*** H 163
M90605010	*** P15	*** H 122	M91055020	*** P5	*** C 119	M91652020	*** P15	*** H 146	M96001001	*** P17	*** J 127
M90611060	*** P19	*** K 121	↑	*** P21	*** L 126	M91688015	*** P13	*** G 109	M96002001	*** P17	*** J 130
M90624053	*** P31	*** R 125	M91056004	*** P33	*** S 109	M91689015	*** P13	*** G 107	M96002017	*** P31	*** R 123
M90630050	*** P31	*** R 124	↑	*** P23	*** M 102	M91801035	*** P13	*** G 101	↑	*** P3	*** B 113
M90631050	*** P3	*** B 112	↑	*** P13	*** G 104	M91802006	*** P9	*** E 132	M96002020	*** P11	*** F 114
↑	*** P13	*** G 123	↑	*** P15	*** H 142	M91802045	*** P11	*** F 105	M96004052	*** P15	*** H 129
M90632050	*** P13	*** G 133	↑	*** P19	*** K 122	↑	*** P13	*** G 102	M96004070	*** P19	*** K 112
M90710050	*** P29	*** Q 103	M91057004	*** P27	*** P 116	M91803022	*** P3	*** B 108	M96020021	*** P31	*** R 122
M90802003	*** P11	*** F 129	↑	*** P3	*** B 128	M91910080	*** P3	*** B 105	M97318099	*** P33	*** S 119
↑	*** P23	*** M 112	M91057020	*** P23	*** M 117	M92008045	*** P29	*** Q 105	M97319099	*** P33	*** S 117
M90802053	*** P29	*** Q 104	↑	*** P5	*** C 128	M92514045	*** P19	*** K 104	M97320099	*** P33	*** S 118

索引
INDEX-2

部品コード Parts No.	ページ Page	Fig No.	部品コード Parts No.	ページ Page	Fig No.	部品コード Parts No.	ページ Page	Fig No.	部品コード Parts No.	ページ Page	Fig No.
M97321099	*** P33 ***	S 901	MB60A0560	*** P31 ***	R 127	MB62A0456	*** P17 ***	J 125	MB63A0797	*** P33 ***	S 112
M97356099	*** P23 ***	M 103	MB60A0601	*** P3 ***	B 126	MB62A0470	*** P3 ***	B 115	ME03A0270	*** P23 ***	M 119
M98003015	*** P11 ***	F 108	MB60A0694	*** P9 ***	E 111	MB62A0523	*** P17 ***	J 134	ME03E5688	*** P25 ***	N 122
M99002022	*** P19 ***	K 115	MB60A0719	*** P29 ***	Q 107	MB62A0572	*** P21 ***	L 115	ME10A0148	*** P11 ***	F 112
M99006063	*** P13 ***	G 114	MB60A0740	*** P11 ***	F 102	MB62A0595	*** P29 ***	Q 101	ME10A0261	*** P13 ***	G 103
↑	*** P5 ***	C 130	MB60A0750	*** P3 ***	B 111	MB62A0601	*** P7 ***	D 107	ME10A0408	*** P27 ***	P 105
MA04A1530	*** P5 ***	C 104	MB60A0915	*** P23 ***	M 105	MB62A0626	*** P13 ***	G 140	ME10A0572	*** P13 ***	G 105
MA10A0120	*** P11 ***	F 121	MB60A1368	*** P29 ***	Q 106	MB62A0707	*** P21 ***	L 108	ME10A0742	*** P3 ***	B 104
MA10A0123	*** P11 ***	F 119	MB60A1429	*** P17 ***	J 115	MB62A0757	*** P27 ***	P 125	ME10A0763	*** P13 ***	G 111
↑	*** P31 ***	R 102	MB60A1601	*** P5 ***	C 118	MB62A0762	*** P35 ***	T 117	ME10A0956	*** P13 ***	G 124
MA10B2476	*** P15 ***	H 125	MB60A1620	*** P33 ***	S 111	MB62A0767	*** P17 ***	J 138	ME10A1252	*** P13 ***	G 142
MA10E0746	*** P15 ***	H 117	MB60A1780	*** P25 ***	N 128	MB62A0777	*** P33 ***	S 116	ME10A1780	*** P25 ***	N 101
MA16A0495	*** P27 ***	P 127	MB60A1990	*** P31 ***	R 106	MB62A0921	*** P19 ***	K 102	ME10A1956	*** P13 ***	G 118
MA16E0210	*** P5 ***	C 904	MB60A2352	*** P27 ***	P 118	MB62A0950	*** P21 ***	L 101	ME10A6910	*** P13 ***	G 110
MA20A0194	*** P5 ***	C 127	MB60A2601	*** P17 ***	J 116	MB62A0957	*** P21 ***	L 122	ME10A7910	*** P13 ***	G 112
MA20A0257	*** P7 ***	D 103	MB60A2620	*** P33 ***	S 110	MB62A1352	*** P7 ***	D 114	ME10E0270	*** P23 ***	M 901
MA20A0392	*** P15 ***	H 134	↑	*** P3 ***	B 141	MB62A1407	*** P17 ***	J 117	ME10E0452	*** P11 ***	F 902
MA20A0458	*** P7 ***	D 105	MB60A3957	*** P29 ***	Q 109	MB62A1434	*** P21 ***	L 105	ME10E1830	*** P3 ***	B 102
MA20A0476	*** P5 ***	C 105	MB60A5339	*** P27 ***	P 110	MB62A1454	*** P17 ***	J 128	ME10E3601	*** P23 ***	M 104
MA20A0584	*** P5 ***	C 141	MB60A5601	*** P27 ***	P 113	MB62A1470	*** P15 ***	H 120	ME20A0406	*** P9 ***	E 101
MA20A0603	*** P15 ***	H 113	MB60A5780	*** P27 ***	P 111	MB62A1523	*** P17 ***	J 142	ME20A1780	*** P25 ***	N 132
MA20A0613	*** P31 ***	R 116	MB60A6780	*** P27 ***	P 112	MB62A1599	*** P27 ***	P 121	ME20E0990	*** P31 ***	R 901
MA20A0650	*** P19 ***	K 126	MB60A8601	*** P7 ***	D 106	MB62A1601	*** P7 ***	D 102	ME25A0230	*** P9 ***	E 121
MA20A0734	*** P33 ***	S 115	MB60E0150	*** P29 ***	Q 901	MB62A1762	*** P35 ***	T 118	ME25A0339	*** P3 ***	B 134
MA20A0740	*** P11 ***	F 113	MB60E0234	*** P9 ***	E 904	MB62A1957	*** P21 ***	L 119	ME25A0389	*** P27 ***	P 107
MA20A0980	*** P23 ***	M 118	MB60E0682	*** P9 ***	E 113	MB62A2272	*** P19 ***	K 116	ME25A0390	*** P19 ***	K 105
MA20A1780	*** P25 ***	N 133	MB60E1682	*** P9 ***	E 901	MB62A2359	*** P7 ***	D 111	ME25A0408	*** P27 ***	P 108
MA20A1910	*** P15 ***	H 137	MB60E2148	*** P25 ***	N 111	MB62A2454	*** P19 ***	K 101	ME25A0416	*** P9 ***	E 145
MA20A4920	*** P17 ***	J 111	MB60E2750	*** P5 ***	C 129	MB62A2599	*** P27 ***	P 122	ME25A0434	*** P13 ***	G 153
MA20A5920	*** P17 ***	J 107	MB60E3339	*** P23 ***	M 902	MB62A4601	*** P3 ***	B 122	ME25A0454	*** P9 ***	E 139
MA20A6571	*** P27 ***	P 128	MB60E6339	*** P3 ***	B 124	MB62A5352	*** P7 ***	D 116	ME25A0477	*** P13 ***	G 149
MA20A8571	*** P33 ***	S 123	MB61A0436	*** P23 ***	M 113	MB62A6339	*** P7 ***	D 119	ME25A0484	*** P27 ***	P 109
↑	*** P27 ***	P 124	MB61A0571	*** P17 ***	J 129	MB62A6352	*** P7 ***	D 118	ME25A0530	*** P5 ***	C 110
MA20E3688	*** P25 ***	N 123	MB61A0601	*** P3 ***	B 101	MB62A7339	*** P7 ***	D 115	ME25A0551	*** P5 ***	C 107
MA21P0454	*** P17 ***	J 137	MB61A0758	*** P17 ***	J 145	MB62E0131	*** P33 ***	S 104	ME25A0571	*** P13 ***	G 152
MA22A0477	*** P21 ***	L 120	MB61A0767	*** P17 ***	J 143	MB62E0148	*** P25 ***	N 129	ME25A0600	*** P5 ***	C 101
MA22A2957	*** P21 ***	L 121	MB61A0963	*** P33 ***	S 122	MB62E0450	*** P11 ***	F 117	ME25A0601	*** P13 ***	G 151
MA30A0571	*** P31 ***	R 130	MB61A1454	*** P17 ***	J 150	MB62E0599	*** P27 ***	P 901	ME25A0682	*** P9 ***	E 141
MA35A0256	*** P35 ***	T 109	MB61A1477	*** P21 ***	L 116	MB62E0776	*** P33 ***	S 101	ME25A0692	*** P19 ***	K 103
MA35A1256	*** P35 ***	T 110	MB61A1758	*** P17 ***	J 148	MB62E0849	*** P3 ***	B 106	ME25A0738	*** P13 ***	G 148
MA35A1781	*** P17 ***	J 135	MB61A2477	*** P19 ***	K 125	MB62E0956	*** P11 ***	F 901	ME25A0781	*** P19 ***	K 106
MA35A2572	*** P9 ***	E 138	MB61A2767	*** P17 ***	J 149	MB62E0957	*** P17 ***	J 103	ME25A0833	*** P9 ***	E 137
MA35A6758	*** P17 ***	J 140	MB61A3454	*** P21 ***	L 102	MB62E0975	*** P15 ***	H 139	ME25A0921	*** P19 ***	K 111
MB02A0608	*** P31 ***	R 118	MB61A5601	*** P33 ***	S 120	MB62E1148	*** P25 ***	N 121	ME25A0950	*** P5 ***	C 106
MB02A1608	*** P31 ***	R 117	MB61E0519	*** P15 ***	H 114	MB62E1957	*** P17 ***	J 110	ME25A1454	*** P13 ***	G 155
MB05E0519	*** P15 ***	H 144	MB61E0982	*** P23 ***	M 116	MB62E2339	*** P7 ***	D 110	ME25A1484	*** P27 ***	P 104
MB25A0426	*** P3 ***	B 116	MB61E1519	*** P23 ***	M 106	MB62E2477	*** P17 ***	J 112	ME25A2339	*** P27 ***	P 106
MB25A1477	*** P17 ***	J 118	MB62A0228	*** P19 ***	K 124	MB62E2601	*** P17 ***	J 104	ME25E0190	*** P5 ***	C 902
MB25A2477	*** P17 ***	J 109	MB62A0263	*** P21 ***	L 124	MB62E3105	*** P35 ***	T 115	ME25E0331	*** P9 ***	E 906
MB45A0767	*** P17 ***	J 126	MB62A0272	*** P35 ***	T 116	MB62E3148	*** P25 ***	N 110	ME25E0688	*** P25 ***	N 118
MB60A0201	*** P33 ***	S 113	MB62A0339	*** P3 ***	B 107	MB62E3339	*** P7 ***	D 112	ME25E0691	*** P31 ***	R 902
MB60A0366	*** P27 ***	P 117	MB62A0352	*** P5 ***	C 131	MB62E4105	*** P19 ***	K 901	ME25E1688	*** P25 ***	N 120
MB60A0419	*** P31 ***	R 104	MB62A0453	*** P11 ***	F 132	MB62E4148	*** P25 ***	N 119	ME25E3688	*** P25 ***	N 127
MB60A0420	*** P33 ***	S 108	MB62A0454	*** P15 ***	H 132	MB62E4339	*** P7 ***	D 117	ME40A0426	*** P19 ***	K 123
MB60A0429	*** P17 ***	J 119	MB62A0455	*** P19 ***	K 114	↑	*** P7 ***	D 120	ME40A0454	*** P19 ***	K 117

索引
INDEX-3

部品コード Parts No.	ページ Page	Fig No.	部品コード Parts No.	ページ Page	Fig No.	部品コード Parts No.	ページ Page	Fig No.	部品コード Parts No.	ページ Page	Fig No.
ME40A0571	*** P13	*** G 157	MN10A1456	*** P9	*** E 104	MS02B0257	*** P19	*** K 119			
MF00A0181	*** P5	*** C 145	MN10A3245	*** P35	*** T 113	MS02E0460	*** P13	*** G 119			
MF00A0608	*** P31	*** R 119	MN52A1245	*** P5	*** C 153	MS02E0983	*** P23	*** M 110			
MF00A2780	*** P25	*** N 106	↑	*** P31	*** R 107	MS03A0101	*** P35	*** T 101			
MF00E0550	*** P5	*** C 903	MN55A0975	*** P21	*** L 104	MS03A0181	*** P31	*** R 110			
MF01A0181	*** P9	*** E 131	MN60A0620	*** P25	*** N 117	MS03A0256	*** P35	*** T 107			
MF01A0259	*** P9	*** E 107	↑	*** P3	*** B 140	MS03A0262	*** P13	*** G 138			
MF01A0476	*** P9	*** E 110	MN60A0750	*** P15	*** H 110	MS03A0417	*** P31	*** R 103			
MF01A0565	*** P31	*** R 108	MN70A1780	*** P13	*** G 116	↑	*** P5	*** C 126			
MF01A1476	*** P9	*** E 108	MN72A1694	*** P9	*** E 109	MS03A0703	*** P13	*** G 132			
MF10A0149	*** P31	*** R 121	MS01A0121	*** P11	*** F 125	MS03A1101	*** P15	*** H 123			
MF10A0181	*** P5	*** C 161	MS01A0160	*** P3	*** B 132	MS03A1256	*** P35	*** T 108			
MF10A0187	*** P5	*** C 156	MS01A0192	*** P15	*** H 135	MS03A1572	*** P13	*** G 134			
MF10A0267	*** P13	*** G 137	MS01A0329	*** P11	*** F 127	MS03A2101	*** P35	*** T 102			
MF10A0325	*** P9	*** E 135	MS01A0348	*** P15	*** H 147	MS03A2780	*** P25	*** N 113			
MF10A0553	*** P5	*** C 157	MS01A0350	*** P9	*** E 124	MS03A6154	*** P13	*** G 106			
MF10A0555	*** P5	*** C 114	MS01A0361	*** P3	*** B 119	MS03B0838	*** P15	*** H 128			
MF10A0709	*** P5	*** C 158	MS01A0383	*** P9	*** E 905	MS03E0662	*** P9	*** E 134			
MF10A1245	*** P35	*** T 112	MS01A0477	*** P3	*** B 133	MS04E1210	*** P35	*** T 111			
MF10A1555	*** P5	*** C 147	MS01A0508	*** P11	*** F 106	MS05A0976	*** P31	*** R 133			
MF10A2740	*** P25	*** N 102	MS01A0572	*** P11	*** F 131	MS05A1976	*** P31	*** R 132			
MF20A0130	*** P33	*** S 106	MS01A0611	*** P11	*** F 122	MS06A0567	*** P31	*** R 128			
MF21D0181	*** P9	*** E 128	MS01A0660	*** P9	*** E 126	MS07A0228	*** P15	*** H 105			
MF36A0245	*** P5	*** C 148	MS01A0663	*** P9	*** E 125	MS08A0454	*** P15	*** H 156			
MF36A0750	*** P15	*** H 103	MS01A0740	*** P25	*** N 115	MS08A0616	*** P11	*** F 120			
MF36A1180	*** P5	*** C 143	MS01A0761	*** P11	*** F 116	MS08A0708	*** P15	*** H 154			
MF40E0193	*** P31	*** R 105	MS01A0833	*** P11	*** F 103	MS09A0950	*** P11	*** F 124			
MF60A0700	*** P13	*** G 126	MS01A0891	*** P11	*** F 109	MS10A0232	*** P9	*** E 903			
MF60A0742	*** P25	*** N 103	MS01A1392	*** P15	*** H 159	MS10A0780	*** P25	*** N 131			
MF60A2740	*** P9	*** E 123	MS01A1476	*** P15	*** H 124	MS10A0976	*** P31	*** R 115			
MF60A5740	*** P25	*** N 125	MS01A1572	*** P15	*** H 148	MS10A0982	*** P23	*** M 115			
MF70A0350	*** P13	*** G 143	MS01A1616	*** P35	*** T 103	MS10A1456	*** P3	*** B 110			
MF70A0352	*** P9	*** E 117	MS01A1740	*** P25	*** N 112	MS10A1740	*** P9	*** E 115			
MF70A1180	*** P5	*** C 159	MS01A1976	*** P31	*** R 111	MS10A1976	*** P31	*** R 136			
MF80A0780	*** P25	*** N 114	MS01A2392	*** P15	*** H 157	MS10A2976	*** P31	*** R 137			
MF90A0361	*** P15	*** H 104	MS01A2572	*** P15	*** H 155	MS13A0572	*** P19	*** K 120			
MF90A0553	*** P5	*** C 146	MS01A3352	*** P15	*** H 901	MS14A0350	*** P5	*** C 121			
MF90A0976	*** P31	*** R 134	MS01A8796	*** P25	*** N 109	MS14A0553	*** P5	*** C 113			
MG30A0664	*** P9	*** E 127	MS01A9796	*** P25	*** N 130	MS14A0572	*** P5	*** C 124			
MG30A0740	*** P13	*** G 117	MS01E0351	*** P15	*** H 149	MS14A0682	*** P9	*** E 119			
MG30A0760	*** P13	*** G 901	MS01E0430	*** P15	*** H 140	MS14A0740	*** P25	*** N 126			
MG30A0833	*** P13	*** G 120	MS01E0580	*** P9	*** E 902	MS14A0838	*** P15	*** H 126			
MG30B0226	*** P13	*** G 108	MS01E0975	*** P15	*** H 153	MS14A1180	*** P5	*** C 112			
MG30B0740	*** P13	*** G 127	MS02A0128	*** P31	*** R 101	MS14A1620	*** P25	*** N 104			
MG43A0181	*** P5	*** C 150	↑	*** P9	*** E 129	MS14A3601	*** P15	*** H 143			
MG50A0740	*** P9	*** E 114	MS02A0463	*** P13	*** G 902	MS14A3780	*** P25	*** N 124			
MG51A0201	*** P33	*** S 114	MS02A0479	*** P31	*** R 135	MS14E0180	*** P5	*** C 901			
MG75A0265	*** P13	*** G 135	MS02A0778	*** P19	*** K 108	MS17A0125	*** P11	*** F 118			
MG75A1476	*** P5	*** C 111	MS02A0976	*** P31	*** R 114	MS17A1120	*** P35	*** T 104			
MM10A1479	*** P31	*** R 120	MS02A1454	*** P17	*** J 154	MT60A0802	*** P5	*** C 154			
MM11A0245	*** P5	*** C 115	MS02A1477	*** P23	*** M 114	MV30A0256	*** P13	*** G 141			
MM11A0352	*** P11	*** F 110	MS02A1976	*** P31	*** R 113	MV30A1256	*** P35	*** T 105			
MM11A0556	*** P5	*** C 152	MS02A2456	*** P17	*** J 139	MV35A0106	*** P35	*** T 106			
MM11A0702	*** P5	*** C 116	MS02A2976	*** P31	*** R 112	MV88A0740	*** P9	*** E 116			
MN10A0135	*** P25	*** N 107	MS02A4729	*** P23	*** M 111						

MEMO

A series of horizontal dotted lines for writing.

MEMO

A series of horizontal dotted lines for writing.

MEMO

A series of horizontal dotted lines for writing.

 **三菱電機株式会社**

 **MITSUBISHI ELECTRIC CORPORATION**