

PFAFF

3588-04/020

Teileliste

Parts list

Liste de pièces

Lista de piezas

The needle bar of the Pfaff 333 will work. It is about 7MM. shorter than the 3588 needle bar, the part number is 91-712 488-92.

The needle bar of the 1291 part number 91-009 678-91 is about 14 MM. shorter than the 3588 needle bar.

Black foam tape for the sewing template is Part # S1211600.
Call 1 800 890 0970

Diese Teileliste hat für Maschinen ab nachfolgender
Seriennummer Gültigkeit:
This parts list applies to machines from the following
serial numbers onwards:
Cette liste de pièces est valable pour les machines au
numéros de série à partir de:
Esta lista de piezas tiene validez para máquinas a partir del
número de serie siguiente:
2565137 →

Alle Informationen und Abbildungen waren zum Zeitpunkt der Druckgebung auf dem neusten Stand.

Technische Änderungen vorbehalten!

Der Nachdruck, die Vervielfältigung sowie die Übersetzung - auch auszugsweise - aus PFAFF-Teilelisten ist nur mit unserer vorherigen Zustimmung und mit der Quellenangabe gestattet.

At the time of printing, all information and illustrations contained in this document were up to date.

Subject to alteration!

The reprinting, copying or translation of PFAFF Parts lists whether in whole or in part, is only permitted with our previous permission and with written reference to the source.

Au moment de la remise à l'imprimeur, toutes les informations et figures se rapportant à cette machine correspondaient à l'état actuel des connaissances.

Sous réserve de modifications techniques!

Aucune reproduction, photocopie ou traduction - même par extraits - des listes de pièces PFAFF ne peut être effectuée, à condition d'en indiquer l'origine, sans notre autorisation expresse.

Todas las informaciones e ilustraciones de este manual estaban al día en el momento de entregarse para su impresión.

¡ Salvo modificaciones técnicas!

La reimpresión, reproducción y traducción - aunque sólo sea parcial - de las listas de piezas PFAFF sólo está permitida con nuestro permiso previo e indicando la fuente.

**G.M. PFAFF KAISERSLAUTERN
INDUSTRIEMASCHINEN AG**

Postfach 3020
D-67653 Kaiserslautern
Königstr. 154
D-67655 Kaiserslautern

Redaktion/Illustration
Verlag Technische Dokumentation
Postfach 1106
D-77901 Lahr

		Seite Page Page Página
0	Wichtiger Hinweis Important note Avis important Observación importante	0 - 1
1	Vorwort Foreword Avant-propos Notas preliminares	1 - 1
2	Erläuterungen der Schlüsselzeichen Explanation of key markings Explication des symboles Explicaciones de los signos clave	2 - 1
3	Nähmaschine Sewing machine Tête de machine Máquina de coser	
3.01	Gehäuseteile Housing sections Parties du corps Piezas del cárter	3 - 1
3.02	Kopfteile Needle head parts Pièces de tête Piezas de la cabeza	3 - 2
3.03	Armteile Arm parts Pièces de bras Piezas del brazo	3 - 5
3.04	Grundplattenteile Bedplate parts Pièces du plateau fondamental Piezas del cárter	3 - 15
4	Tischplatte Table top Plateau de table Tablero de costura	4 - 1

	Seite Page Page Página
5 Gestell mit Anbauteilen	5 - 1
Stand with assembly parts	
Bâti avec éléments de montage	
Bancada con piezas de montaje	
6 X-Y-Antrieb	6 - 1
X-Y drive	
Système de commande X-Y	
Grupo de accionamiento "X-Y"	
7 Stapler	7 - 1
Stacker	
Empileur	
Apilador	
8 Umbugger	8 - 1
Folder	
Remplieur	
Grupo doblador	
9 Pneumatische Ausrüstung	9 - 1
Pneumatic equipment	
Équipement pneumatique	
Equipo neumático	
10 Elektrische Ausrüstung	
Electrical equipment	
Équipement électrique	
Equipo eléctrico	
10.01 Bedienfeld	10 - 1
Control panel	
Panneau de commande	
Panel de mandos	
10.02 Notausschalter und Nähmotor	10 - 2
Emergency shut-off switch and sewing motor	
Interrupteur d'arrêt d'urgence et moteur de machine à coudre	
Interruptor de emergencia y motor máquina de coser	
10.03 Zweihandbedienung	10 - 3
Operation with both hands	
Commande à deux mains	
Manejo a dos manos	

	Seite Page Page Página
10.04 Steuergerät	10 - 4
Control device	
Boîte de commande	
Caja de mandos	
10.05 Saugereinrichtung	10 - 15
Vacuum system	
Dispositif d'aspiration	
Dispositivo de aspiración	
10.06 Stoffrückhaltevorrichtung	10 - 16
Workpiece retainer	
Dispositif de rétension du tissu	
Dispositivo de retención del material	
11 Verkleidung	11 - 1
Cover panel	
Carters	
Revestimiento	
12 Zubehör	
Accessoires	
Accessoires	
Accesorios	
12.01 Zubehörteile	12 - 1
Accessory parts	
Accessoires	
Accesorios	
12.01 Garnrollenständer	12 - 2
Reel stands	
Porte-bobines	
Portacarretes	
13 Einstellehren	13 - 1
Adjustment gauges	
Calibres	
Calibres de ajuste	
14 Schmiermittel-Übersicht	14 - 1
Overview of lubricants	
Tableau de lubrifiants	
Tabla de lubricantes	

	Seite Page Page Página
15 Optionen Options Options Opciones	
15.01 Diskettenlaufwerk mit Leitung 15 - 1 Disc drive with cable Lecteur de disquettes avec câble Lector de discos con cable	
15.02 Höhenverstellung für Gestell 15 - 2 Vertical adjustment for frame Réglage de la hauteur du bâti Regulación de la altura del bastidor	
15.03 Transportrolle 15 - 7 Feed roller Galet d'entraînement Rodillo el transporte	
15.04 Ecken-Umbuggschieber 15 - 8 Edge folders Glissière rempliage du coin Remetedor de esquinas	
15.05 Taschenblech 15 - 11 Pocket plate Gabarit de poche Chapa del bolsillo	
15.06 Schablonenblech 15 - 13 Jip plate Gabarit Plantilla	
15.07 Anbausatz für variablen Näh Schlitz und Patten 15 - 16 Add-on kit for variable needle slot and flap Jeu de pièces adaptables fente de couture variable et rabats Juego de piezas acoplables para ranura de costura variable y carteras	
15.08 Anbausatz für geteiltes Taschenblech 15 - 17 Add-on kit for split pocket plate Jeu de pièces adaptables pour gabarit de poche segmenté Juego de piezas acoplables para chapa de bolsillo bipartida	

	Seite Page Page Página
15.09 Anbausatz für vorgebuggte Taschen	15 - 18
Add-on kit for pre-folded pockets	
Kit pour poches conformées	
Conjunto de piezas para bolsillo predoblado	
15.10 Etikettenpositioniereinrichtung	15 - 19
Label positioning device	
Dispositif de positionnement d'étiquettes	
Dispositivo posicionador de etiquetas	
15.11 Fußtaster mit Leitung	15 - 20
Foot control with cord	
Interrupteur au pied, avec câble	
Interruptor de pie, con cable	
15.12 Anbausatz für Programmerkennung	15 - 21
Add-on kit for program identification	
Kit pour reconnaissance de programme	
Kit para identificación del programa	
16 Index (Teilenummern / Seitenzahlen)	16 - 1
Index (part numbers / page numbers)	
Index (numéros de pièces, de pages)	
Index (números de pieza / números de página)	

Achtung!



Wir machen ausdrücklich darauf aufmerksam, daß Ersatz- und Zubehörteile, die nicht von uns geliefert werden, auch nicht von uns geprüft und freigegeben sind. Der Einbau und / oder die Verwendung solcher Produkte kann daher u. Umständen konstruktiv vorgegebene Eigenschaften Ihrer Maschine negativ verändern. Für Schäden, die durch die Verwendung von Nicht-Originalteilen entstehen, übernehmen wir keine Haftung!

Caution!



We warn you expressively that spare parts and accessories that are not supplied by us are not tested and released by us. Fitting or using these products may therefore have negative influences on features that depend on the machine design. We are not liable for any damage caused by the use of non-Pfaff parts!

Attention!



Nous attirons expressément votre attention sur le fait que les pièces de rechange et accessoires qui n'ont pas été livrés par nous n'ont pas non plus été contrôlés et agréés par nous. C'est pourquoi le montage et/ou l'utilisation de telles pièces peut éventuellement entraîner l'altération des caractéristiques de construction de votre machine. Par conséquent, nous n'assumons aucune responsabilité pour les dommages causés par l'emploi de pièces qui ne sont pas d'origine!

¡Atención!



Se hace observar que en el caso de piezas de recambio y accesorios que no hayan sido suministrados por nosotros, quiere decir que non han sido sometidas por nuestra parte a un control y que no se les ha dado el visto bueno. Por esta razón, el montaje y/o empleo de tales productos puede repercutir negativamente en las características previstas en su máquina. ¡Para los daños que eventualmente pudiesen presentarse al utilizar piezas no originales, no asumimos ninguna garantía!

- Die Seriennummer der Maschine, für die diese Teileliste Gültigkeit hat, ist auf der Titelseite aufgeführt.
 - Alle Teile sind so abgebildet, wie sie in der Maschine funktionsmäßig zusammengehören.
 - Gestrichelt dargestellte Teile zeigen angrenzende Teile aus anderen Funktionsgruppen.
 - Im oberen Teil der Bildseiten befindet sich eine Gesamtansicht der Maschine.
 - Der Einbauort der dargestellten Teile wird durch eine gerasterte Fläche gekennzeichnet.
 - Einrahmungen auf den Bildseiten zeigen, aus welchen Einzelteilen sich die Gruppenteile zusammensetzen.
 - Die auf den Bildseiten verwendeten Schlüsselzeichen (; 2; 3 usw.) sind im Kapitel "Erläuterungen der Schlüsselzeichen" aufgelistet.
-
- The serial number of the machine to which this parts list applies is indicated on the cover page.
 - All parts are illustrated in function groups with the parts which they function together with in the machine.
 - Parts illustrated with broken lines are parts from other function groups which border on the illustrated function group.
 - The above section of the page of illustrations contains a total view of the machine. The place for the installation of the parts pictured here is marked by the grid.
 - The framed-in sections on the illustration pages show the individual parts comprising a group.
 - The key markings used on the illustrated pages (; 2; 3 etc.) are listed in the chapter "Explanation of key markings".
-
- Le numéro de série de la machine pour laquelle cette liste de pièces est valable est indiqué sur la première page.
 - Toutes les pièces sont représentées en fonction de leur groupement fonctionnel dans la machine.
 - Les pièces hâchurées indiquent les pièces limitrophes de groupes de fonctions différents.
 - La partie supérieure des pages de figures comprend une présentation globale de la machine. L'emplacement des pièces représentées est signalé par quadrillages.
 - Les parties encadrées sur les pages à illustrations représentent les pièces individuelles formant groupe.
 - Vous trouverez au chapitre "Explication des symboles" une liste des symboles utilisés sur les pages de figures (; 2; 3 etc.)
-
- El número de serie de la máquina para la cual tiene validez esta lista de piezas va indicado en la página de título.
 - Todas las piezas están ilustradas tal como aparecen en la máquina para su funcionamiento.
 - Las piezas representadas con rayitas muestran piezas colindantes de otros grupos de funciones.
 - En la parte superior de las páginas ilustradas se puede ver una vista en conjunto de la máquina.
 - El lugar de montaje de la pieza representada va caracterizada mediante una superficie reticulada.
 - Los recuadros en las páginas ilustradas indican las piezas individuales de que se componen los grupos.
 - Los signos clave (; 2; 3 etc.) empleados en las páginas con ilustraciones van listados en el capítulo "Explicaciones de los signos clave".

- 3** **Geklebt**
Part cemented
Pièce collée
Pieza pegada
- 3/1** **Gesichert mit Loctite**
Secured with Loctite
Bloqué par Loctite
Asegurado con Loctite
- 3/4** **Selbstklebend**
Self-adhesive
Auto-adhésif
Autoadhesivo
- 6** **Nadeldicke und Spitzenform bei Bestellung angeben.**
Needle size and style of point to be stated on order.
Préciser la grosseur de l'aiguille et la forme de la pointe à la commande.
Grosor de aguja y forma de la punta, indíquese en los pedidos.
- 22** **Zubehör**
Accessories
Accessories
Accesorios
- 27/2** **Eingeklammerte Zahl = Dicke in mm.**
Number in brackets = thickness in mm.
Chiffre entre parenthèses = épaisseur en mm
Cifra entre paréntesis = espesor en mm.
- 27/5** **Eingeklammerte Zahl = Länge in mm.**
Number in brackets = length in mm.
Chiffre entre parenthèses = longueur en mm
Cifra entre paréntesis = largura en mm.
- 27/19** **Eingeklammerte Zahl = Stichlochbreite in mm.**
Number in brackets = needle hole width in mm.
Chiffre entre parenthèses = largeur du trou d'aiguille en mm
Cifra entre paréntesis = anchura del agujero pasante para la aguja en mm.
- 27/20** **Eingeklammerte Zahl = Stichlochdurchmesser in mm.**
Number in brackets = needle hole diameter in mm.
Chiffre entre parenthèses = diamètre du trou d'aiguille en mm
Cifra entre paréntesis = diámetro del agujero pasante para la aguja en mm.

- 28** Sonderausführung
Special version
Version spéciale
Tipo especial
- 32** Beim Einbau dieses Teiles wird für die Paßgenauigkeit zum Anschlußteil keine Garantie übernommen; zweckmäßig vollständiges Aggregat bestellen.
No guarantee is assumed that this part will fit the mating part; it is best to order a complete assembly.
Aucune garantie ne pourra être assurée quant à la précision d'ajustage de cette pièce avec la pièce correspondante; il est indiqué de commander un mécanisme complet.
Al montar esta pieza no se asume garantía alguna en cuanto a la tolerancia y precisión de ajuste respecto a la pieza correspondiente; por esta razón, se recomienda pedir el grupo completo.
- 32/1** Beim Einbau dieses Teiles ist Nacharbeit erforderlich.
When fitting this part re-work is required.
Retouches nécessaires au montage.
Al montar esta pieza hay que retocarla antes
- 35/1** Bei Montage vernieten.
To be riveted after assembly.
River après montage.
Remáchese después del montaje.
- 40/2** Tränken mit 28-011 201-44; Bestellnummer siehe Seite 14 - 1.
Soak with 28-011 201-44; for part number see page 14 - 1.
Imbiber d'huile 28-011 201-44; n° de commande, voir page 14 - 1.
Empape con aceite 28-011 201-44; para el Número de pedido véase la página 14 - 1.
- 40/3** Fetten mit 28-011 202-47; Bestellnummer siehe Seite 14 - 1.
Grease with 28-011 202-47; for part number see page 14 - 1.
Graiser avec de la graisse 28-011 202-47; n° de commande, voir page 14 - 1.
Engrase con grasa 28-011 202-47; para el Número de pedido véase la página 14 - 1.
- 40/4** Fetten mit 28-011 202-43; Bestellnummer siehe Seite 14 - 1.
Grease with 28-011 202-43; for part number see page 14 - 1.
Graiser avec de la graisse 28-011 202-43; n° de commande, voir page 14 - 1.
Engrase con grasa 28-011 202-43; para el Número de pedido véase la página 14 - 1.
- 40/5** Ölen mit 28-011 201-44; Bestellnummer siehe Seite 14 - 1.
Oil with 28-011 201-44; for part number see page 14 - 1.
Huiler avec de la graisse 28-011 201-44; n° de commande, voir page 14 - 1.
Lubrifique con grasa 28-011 201-44; para el Número de pedido véase la página 14 - 1.

- 40/13** **Fetten mit 28-011 202-05; Bestellnummer siehe Seite 14 - 1.**
Grease with 28-011 202-05; for part number see page 14 - 1.
Graiser avec de la graisse 28-011 202-05; n° de commande, voir page 14 - 1.
Engrase con grasa 28-011 202-05; para el Número de pedido véase la página 14 - 1.
- 40/22** **Füllen mit 28-011 202-10; Bestellnummer siehe Seite 14 - 1.**
Top up with 28-011 202-10; for part number see page 14 - 1.
Remplir de 28-011 202-10; n° de commande, voir page 14 - 1.
Rellene con 28-011 202-10; para el Número de pedido véase la página 14 - 1.
- 81/1** **Stückzahl je nach Bedarf.**
Quantity as required.
Nombre en fonction besoin.
Cantidad según sea necesario.
- 81/3** **Verwendung je nach Bedarf.**
To be used as required.
Utilisation en fonction besoins.
Utilización según sea necesario..
- 96** **Länge angeben.**
State length.
Préciser longueur.
Indíquese la largura

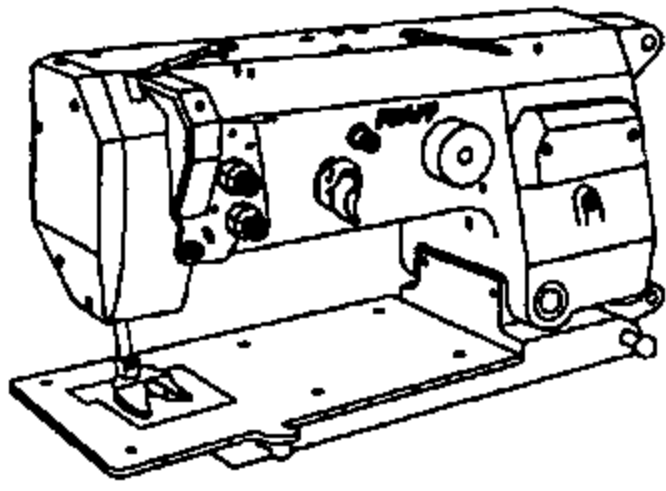

Gehäuseteile
Housing sections
Parties du corps
Piezas del cárter PFAFF 3588-04/020

3.01

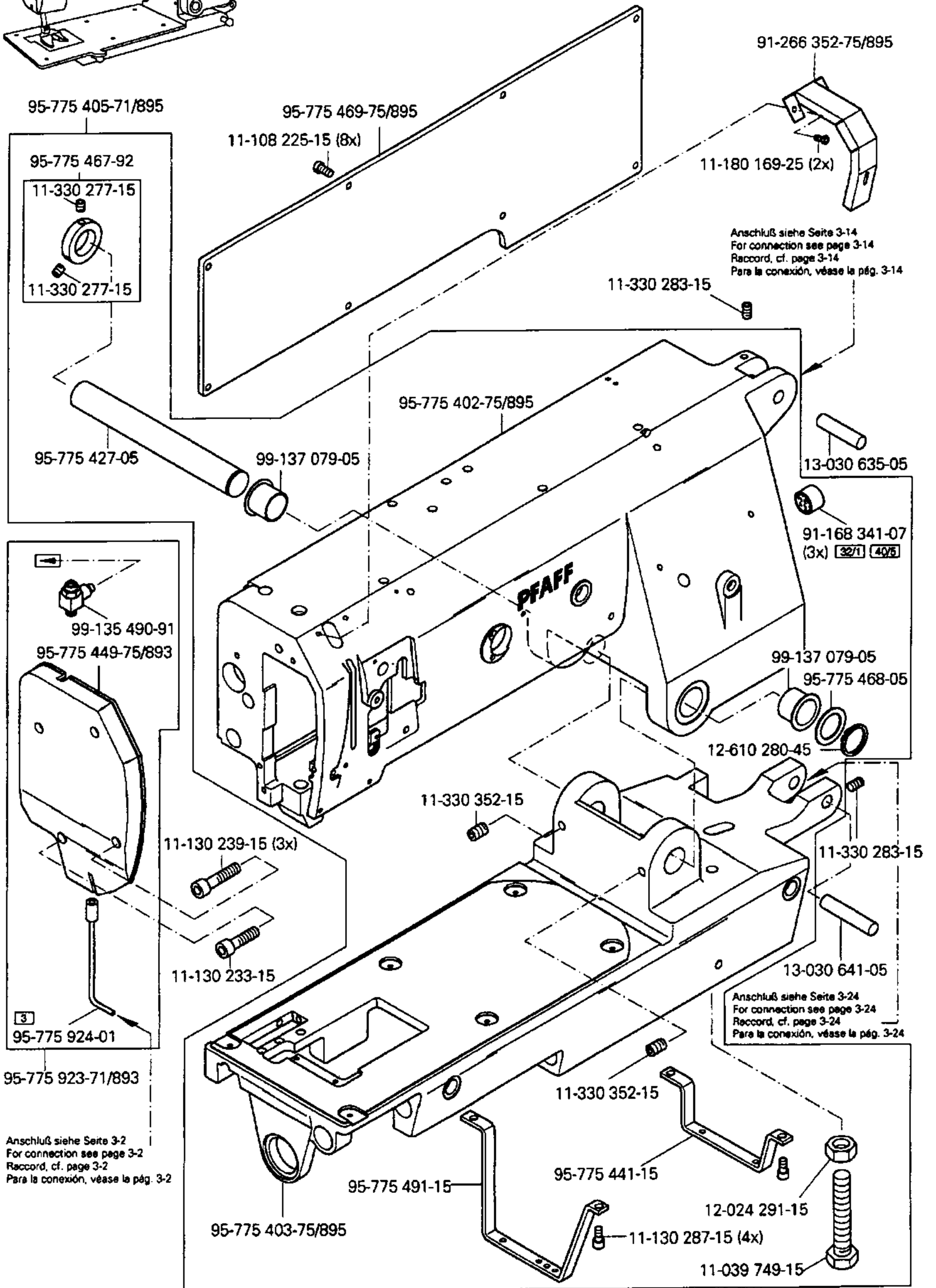

PFAFF

☐ siehe Kapitel 2 Erläuterung der Schlüsselzeichen
see chapter 2 Explanation of key markings
voir le chap. 2 Explication des symboles
véase el Cap. 2 Explicaciones de los signos clave

→ Anschluß siehe Seite 3-2
For connection see page 3-2
Raccord, cf. page 3-2
Para la conexión, véase la pág. 3-2

3.02

Kopfteile
Needle head parts
Pièces de tête
Piezas de la cabeza PFAFF 3588-04/020

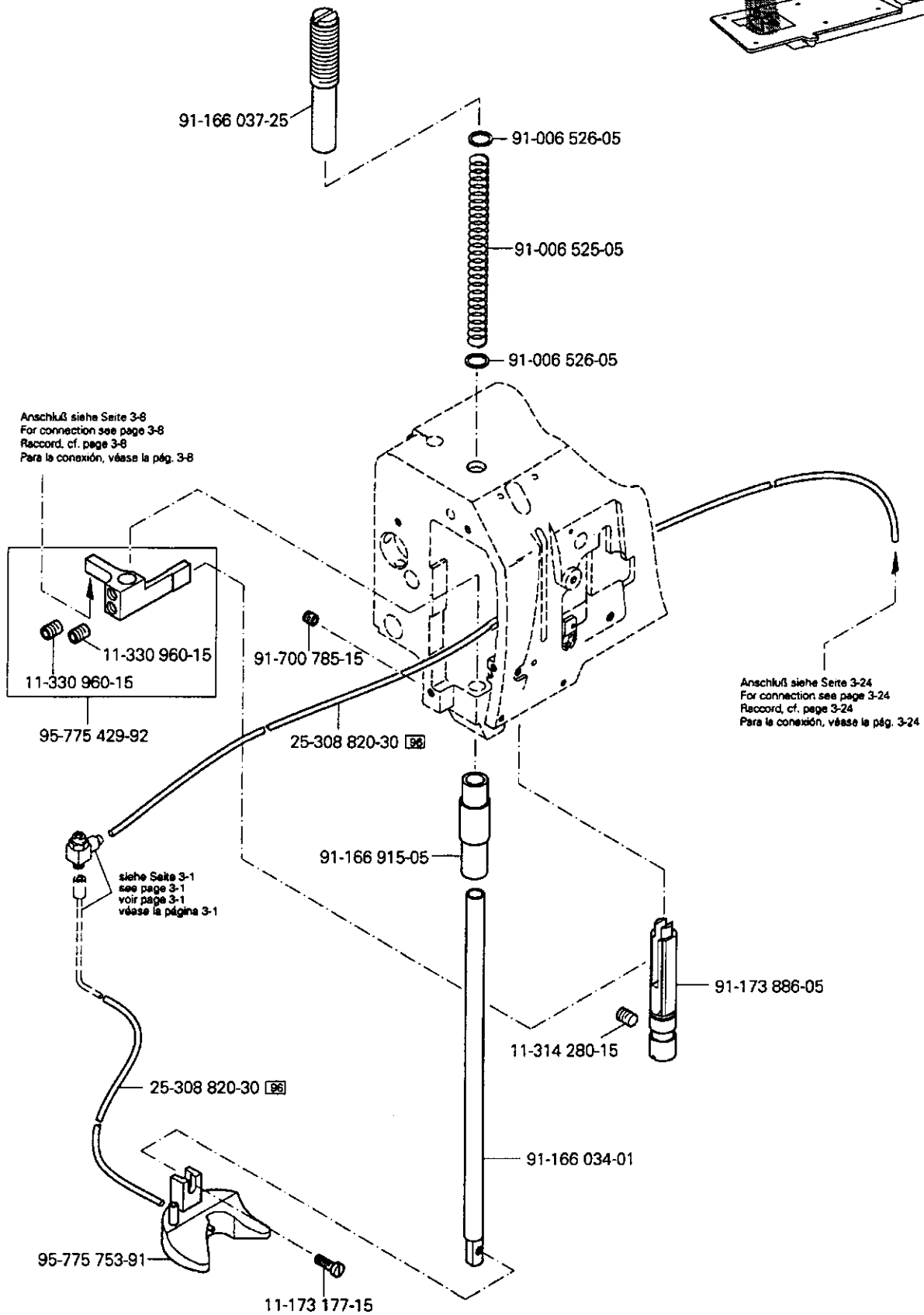
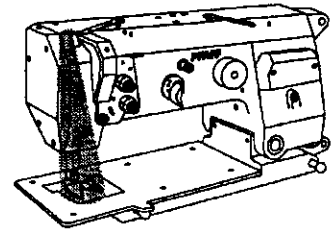

3.02

Kopfteile
Needle head parts
Pièces de tête
Piezas de la cabeza PFAFF 3588-04/020

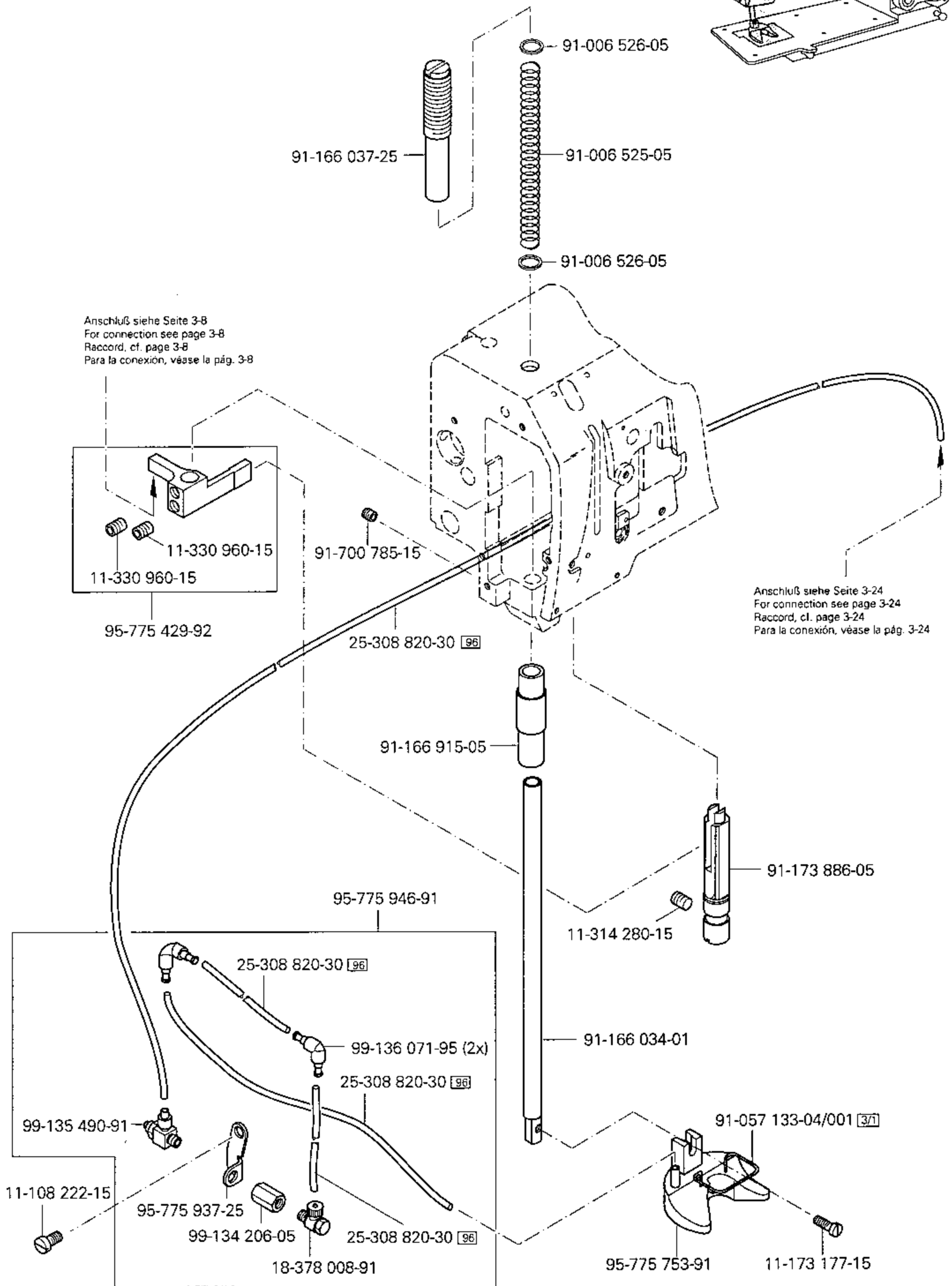
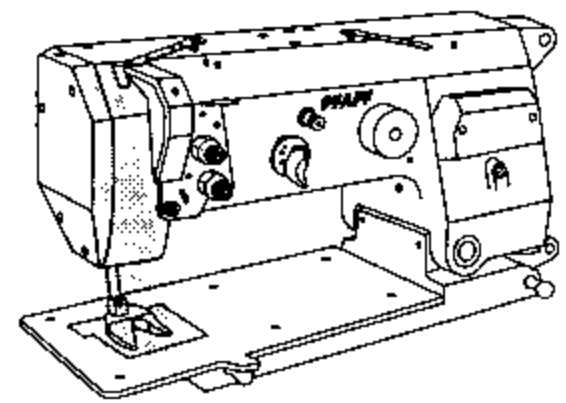

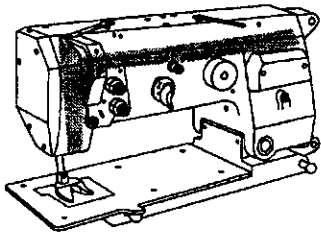

Kopfteile
Needle head parts
Pièces de tête
Piezas de la cabeza PFAFF 3588-04/020

3.02

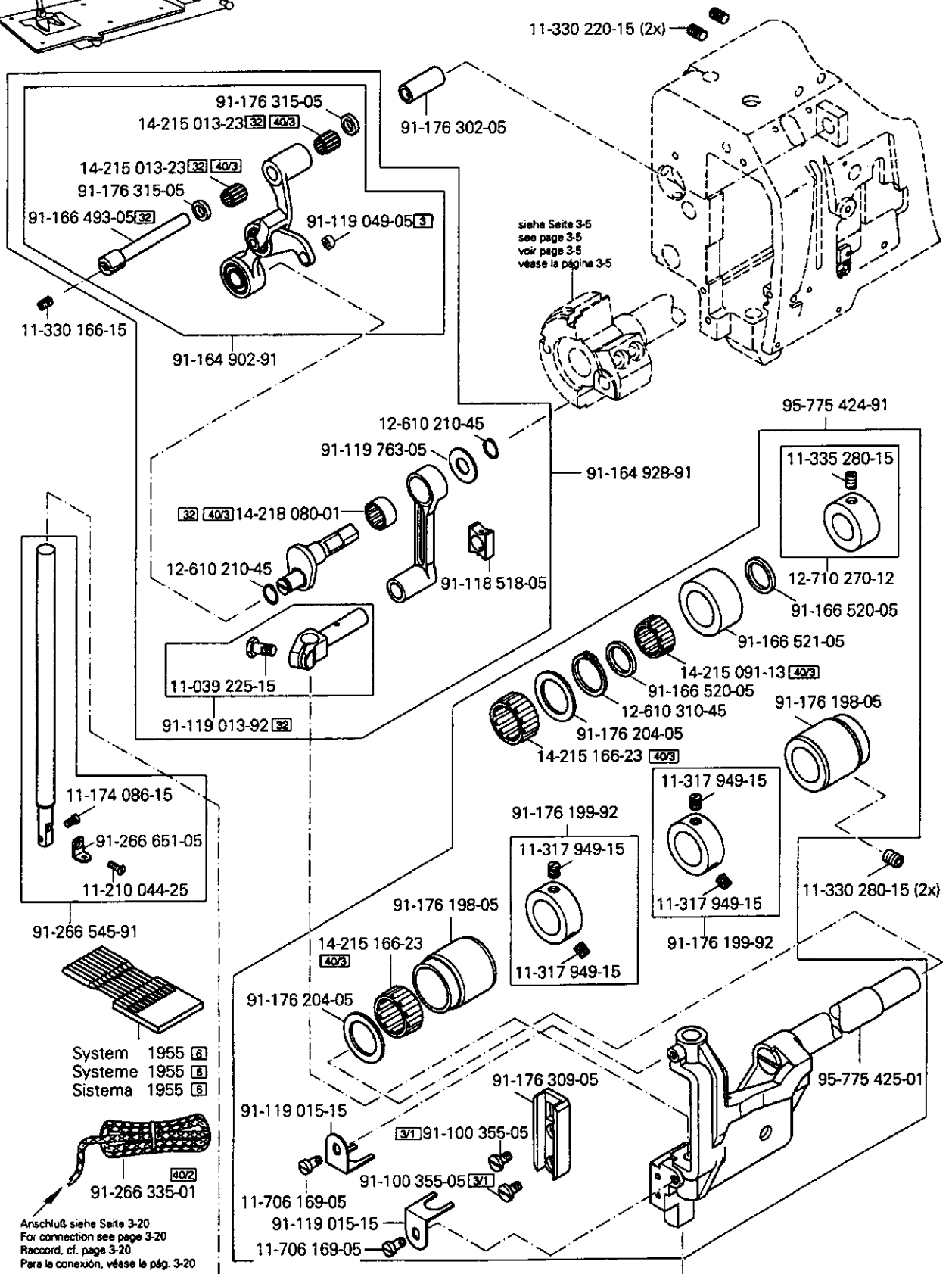

PFAFF

☐ siehe Kapitel 2 Erläuterung der Schlüsselzeichen
see chapter 2 Explanation of key markings
voir le chap. 2 Explication des symboles
véase el Cap. 2 Explicaciones de los signos clave

3.02

Kopfteil
Needle head parts
Pièces de tête
Piezas de la cabeza PFAFF 3588-04/020

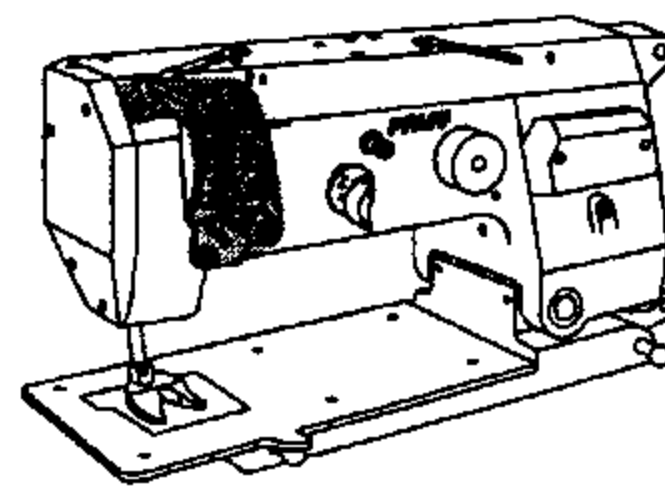

Anschluß siehe Seite 3-23
For connection see page 3-23
Raccord, cf. page 3-23
Para la conexión, véase la pág. 3-23

Anschluß siehe Seite 3-24
For connection see page 3-24
Raccord, cf. page 3-24
Para la conexión, véase la pág. 3-24

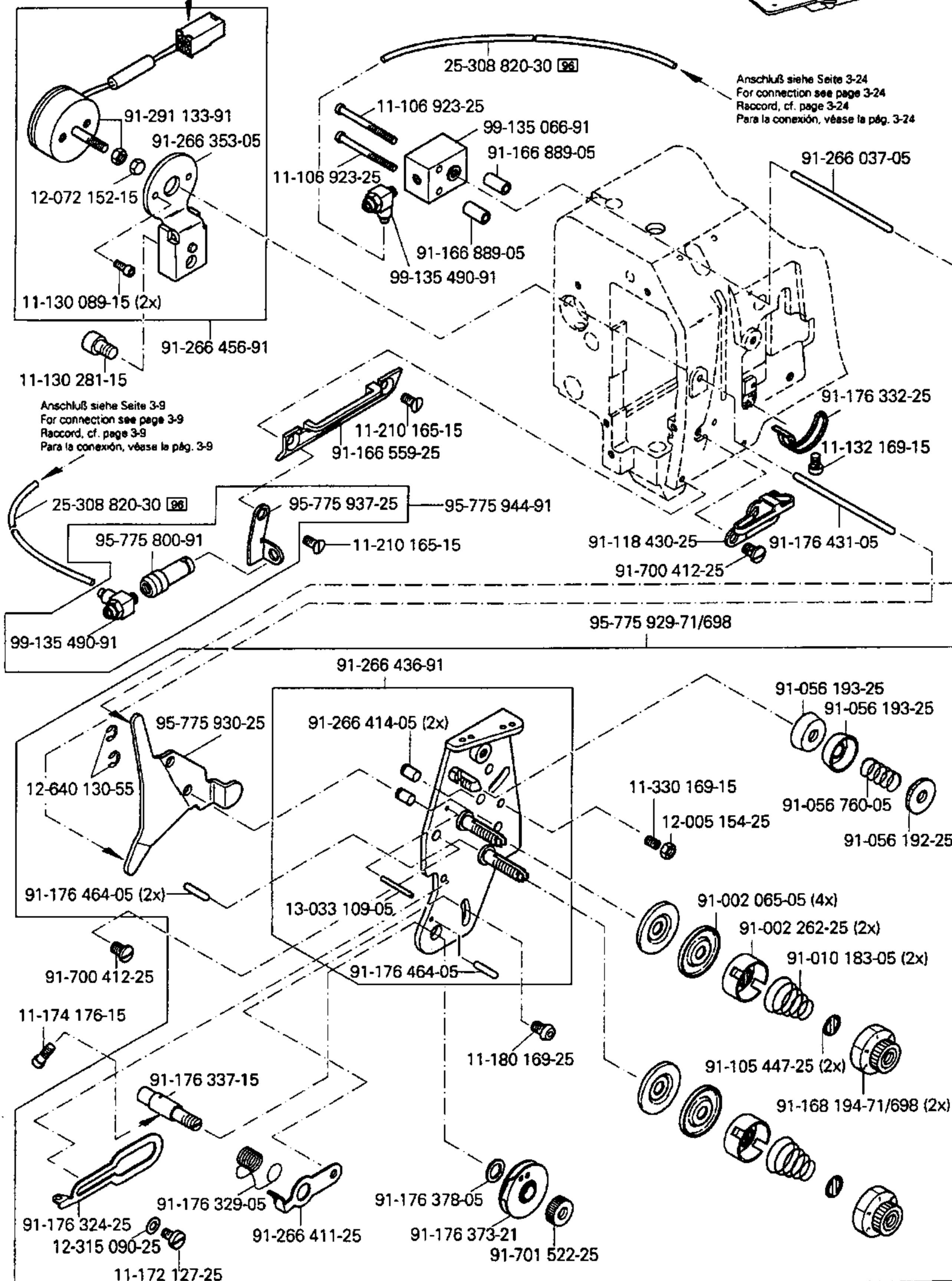

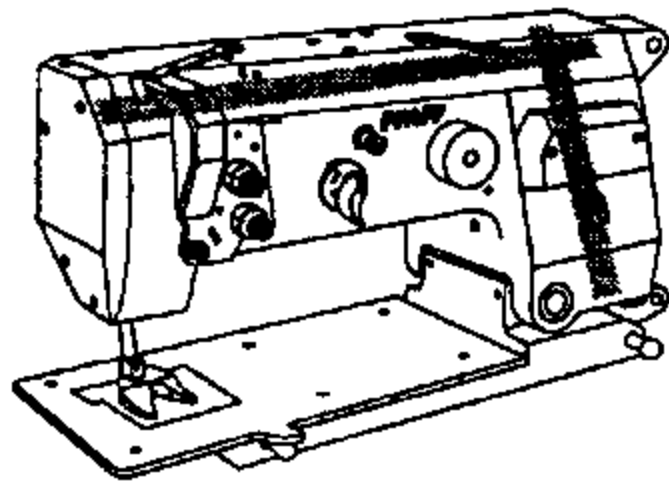

Armteile
 Arm parts
 Pièces de bras
 Piezas del brazo PFAFF 3588-04/020

3.03

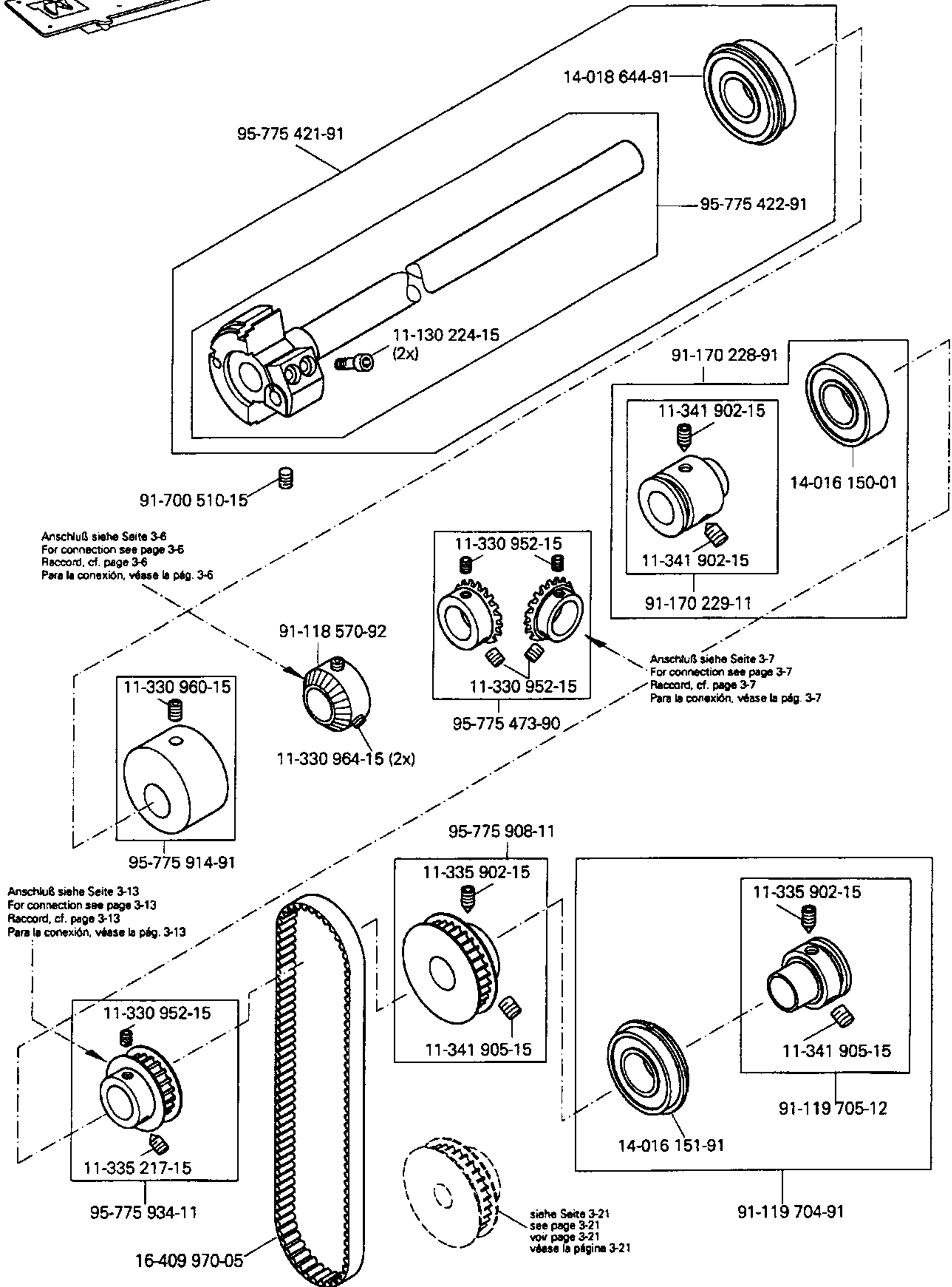

3.03

Armteile
 Arm parts
 Pièces de bras
 Piezas del brazo PFAFF 3588-04/020

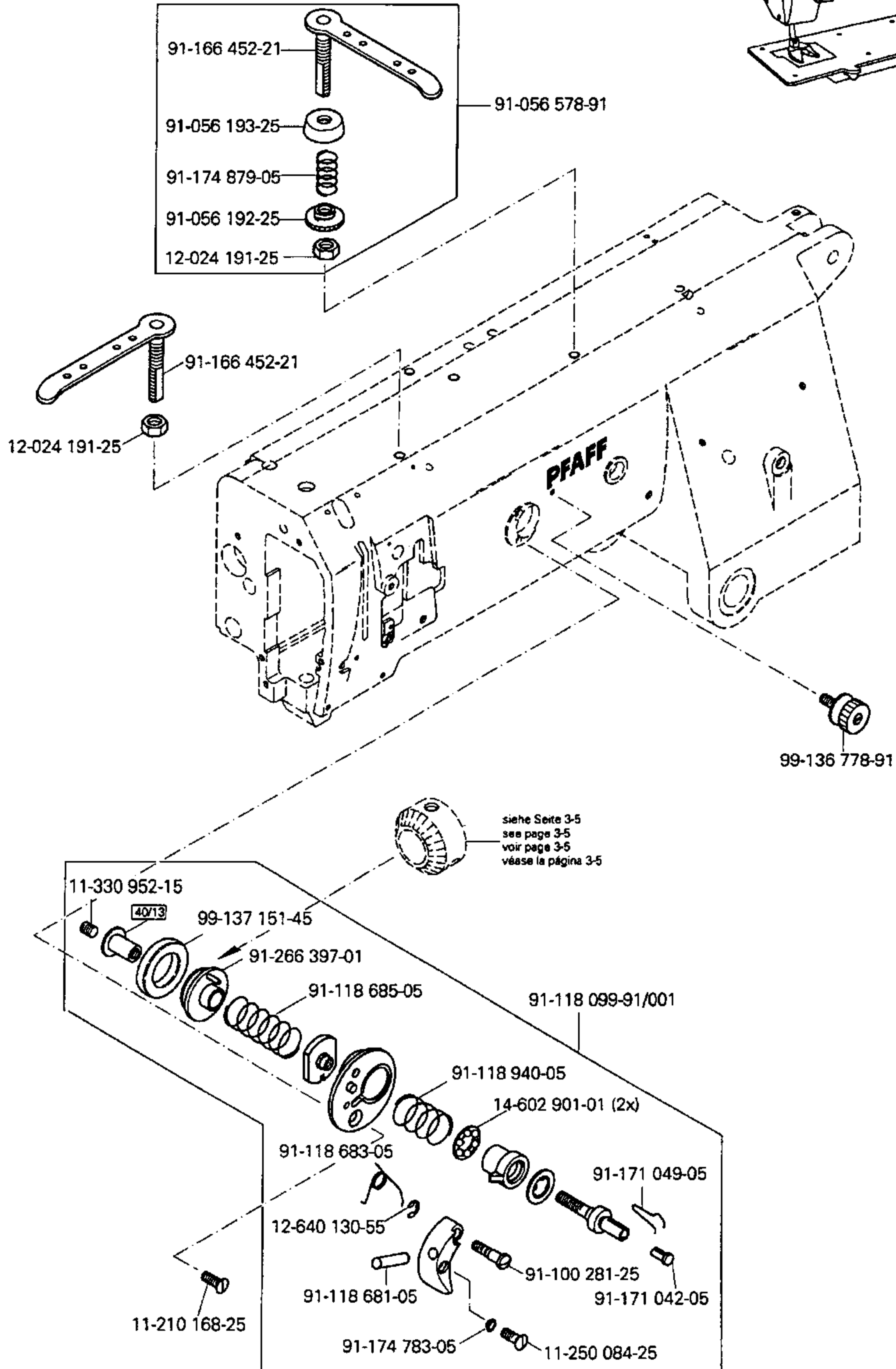
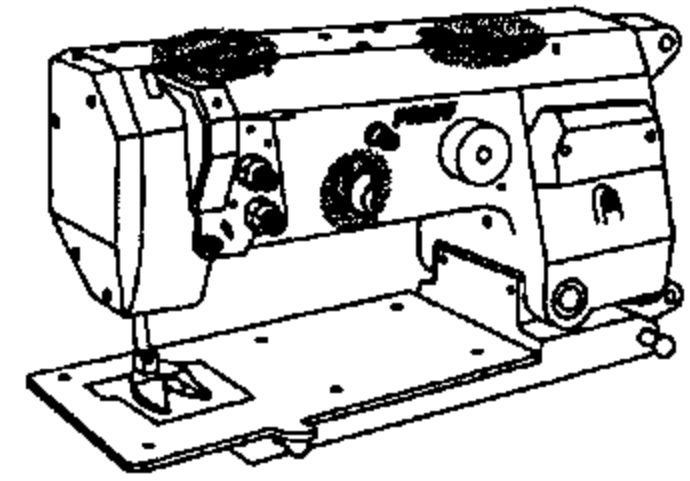

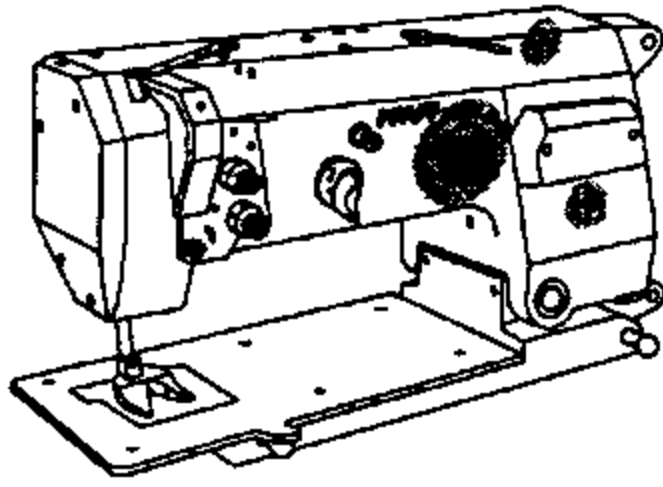

Armteile
 Arm parts
 Pièces de bras
 Piezas del brazo PFAFF 3588-04/020

3.03

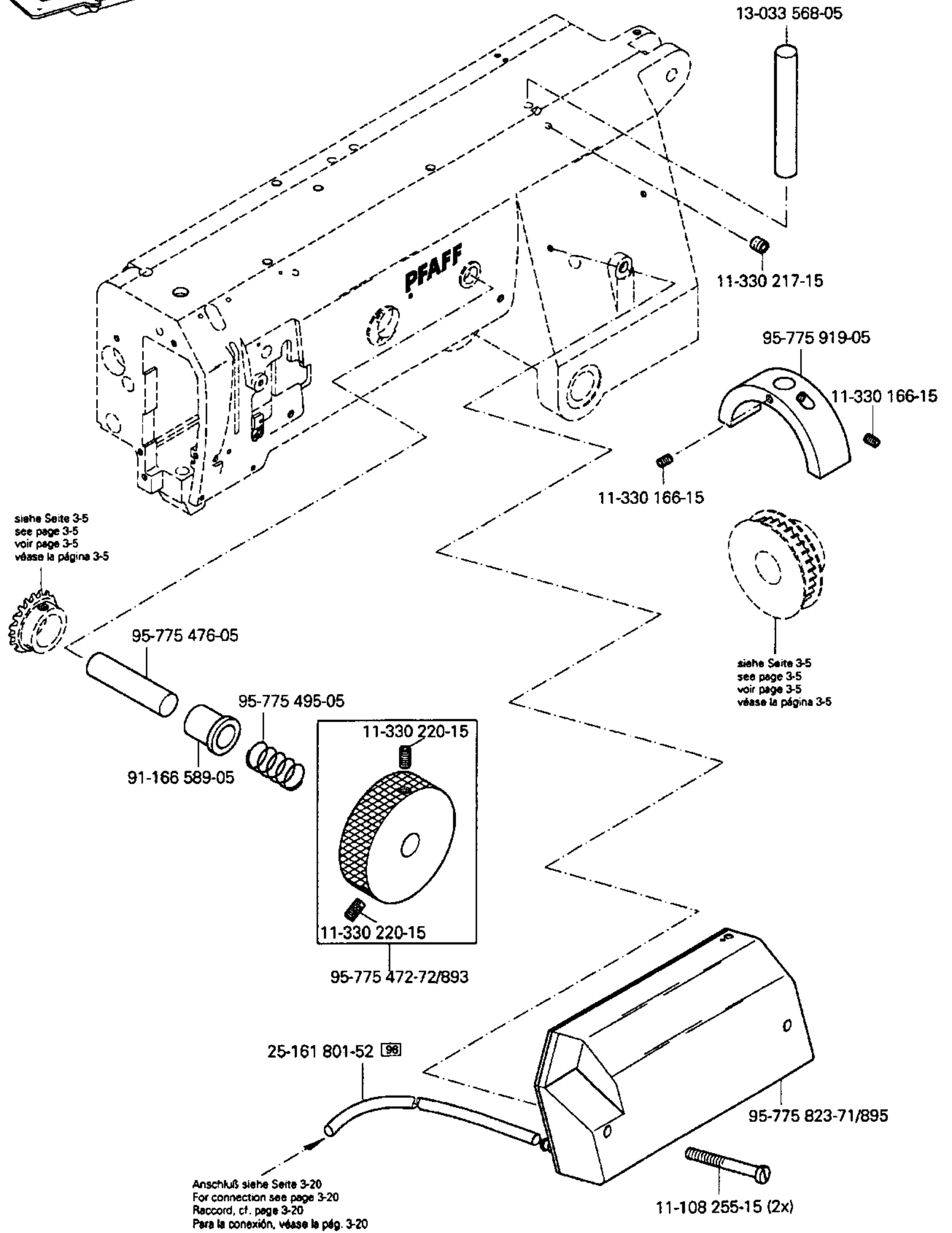

3.03

Armteile
 Arm parts
 Pièces de bras
 Piezas del brazo PFAFF 3588-04/020

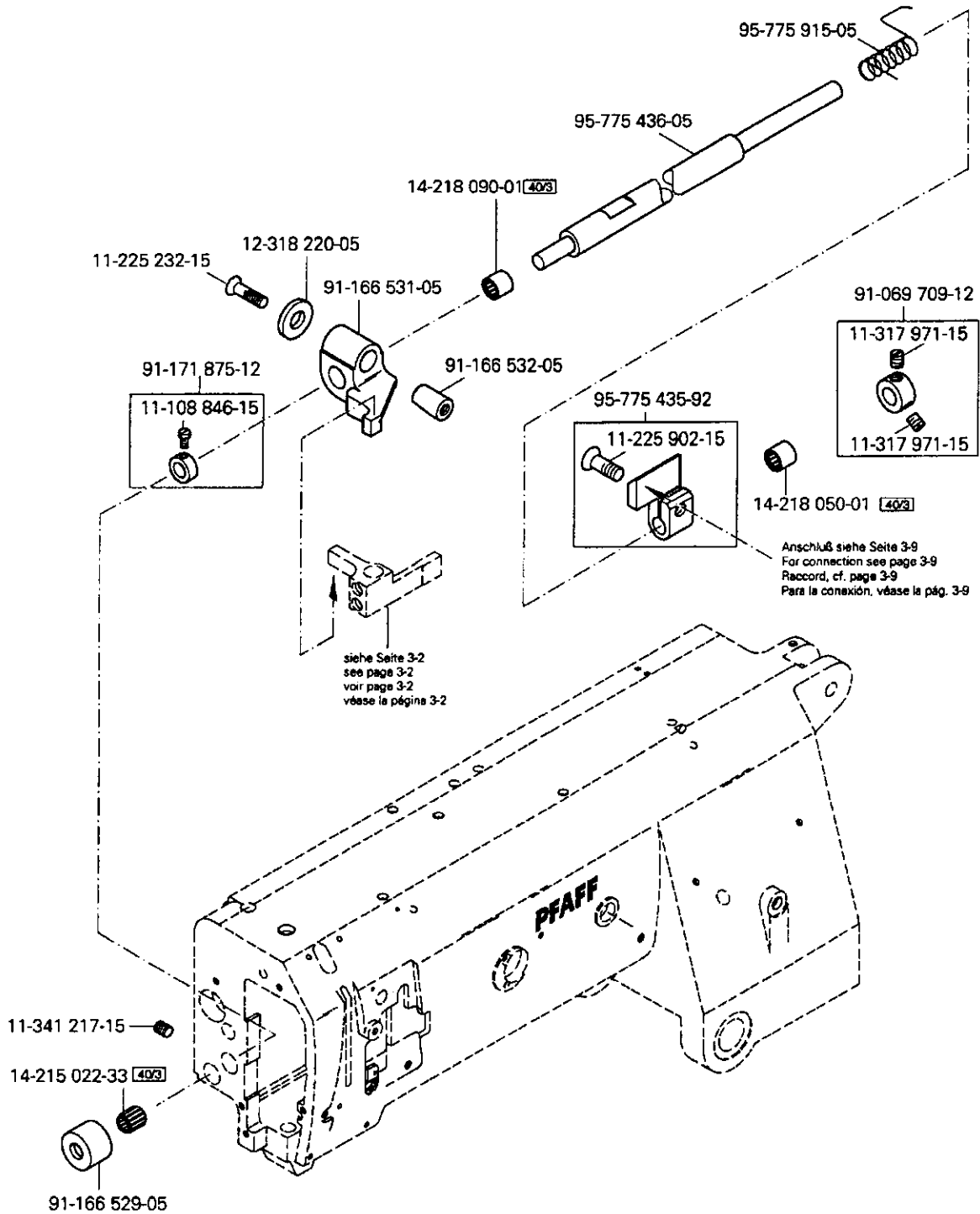
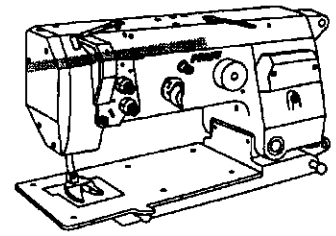

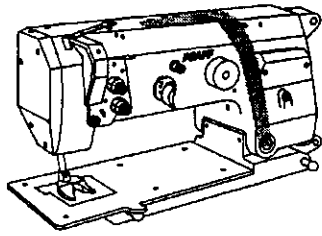

Armteile
 Arm parts
 Pièces de bras
 Piezas del brazo PFAFF 3588-04/020

3.03

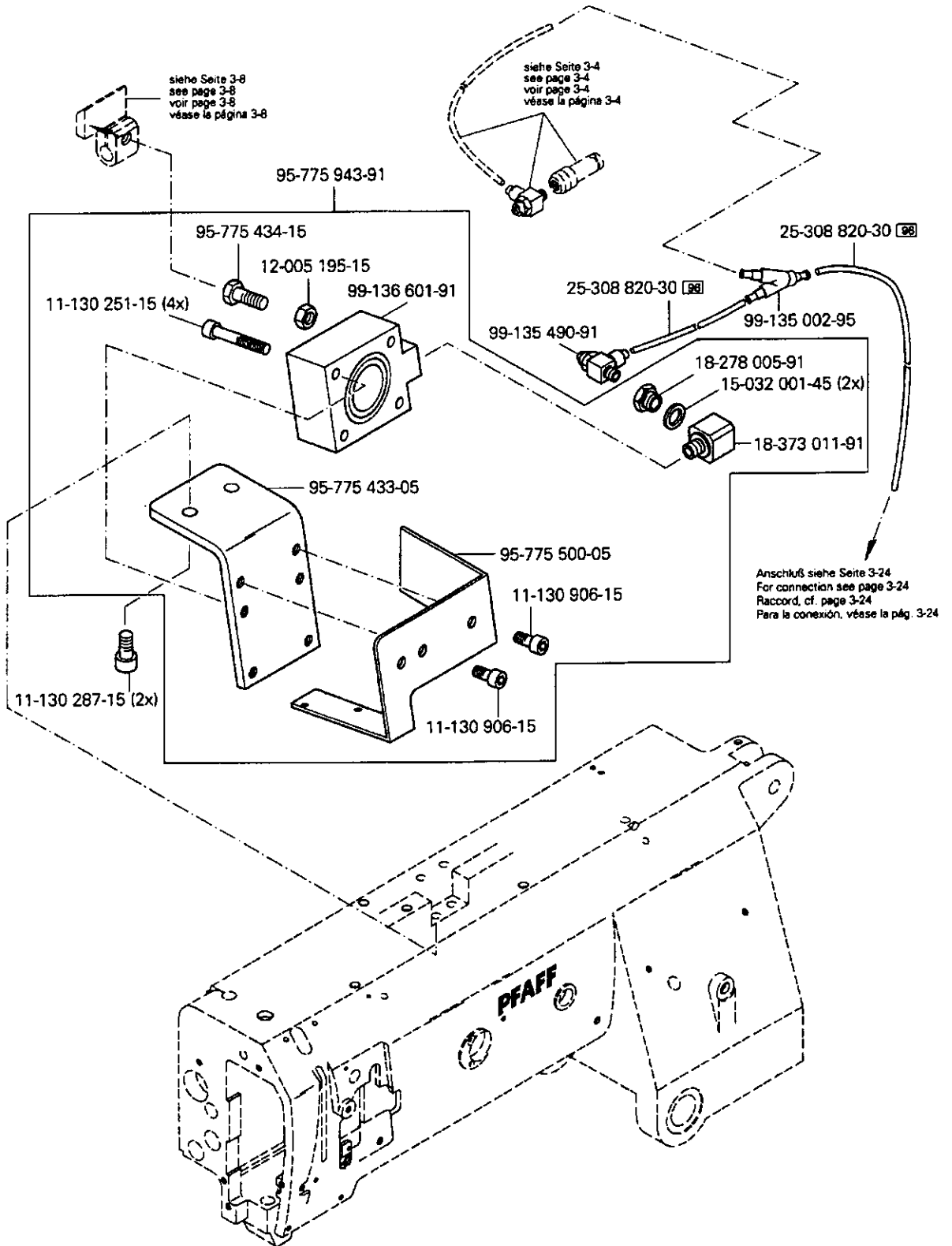

3.03

Armteile
 Arm parts
 Pièces de bras
 Piezas del brazo PFAFF 3588-04/020

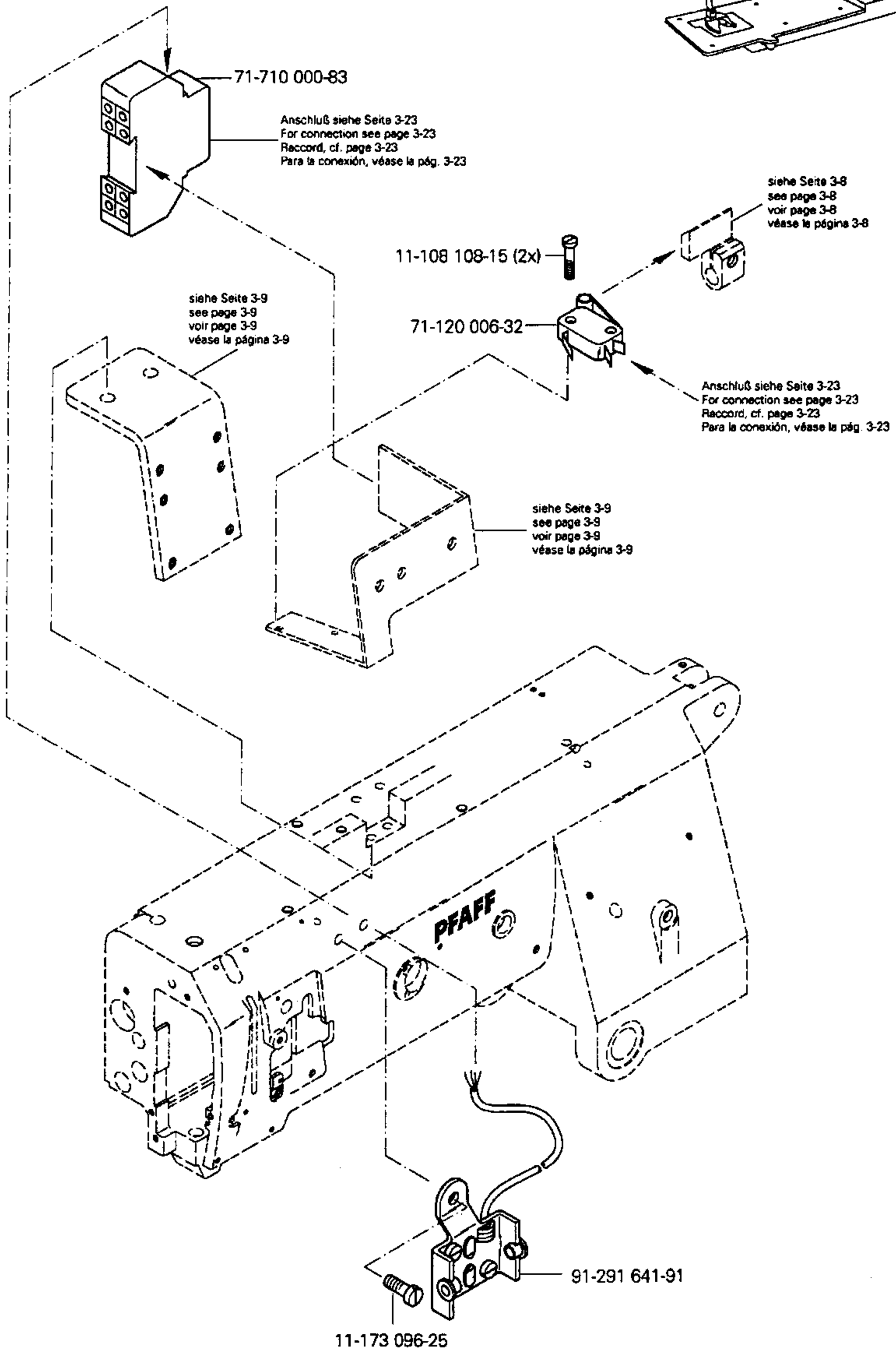
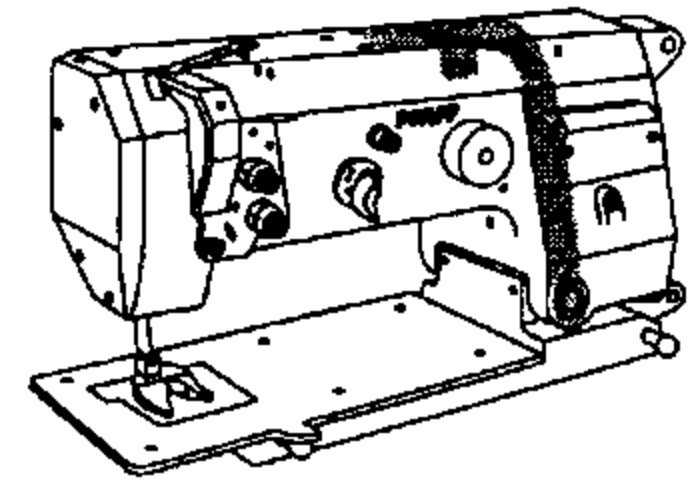

3.03

Armteile
Arm parts
Pièces de bras
Piezas del brazo PFAFF 3588-04/020

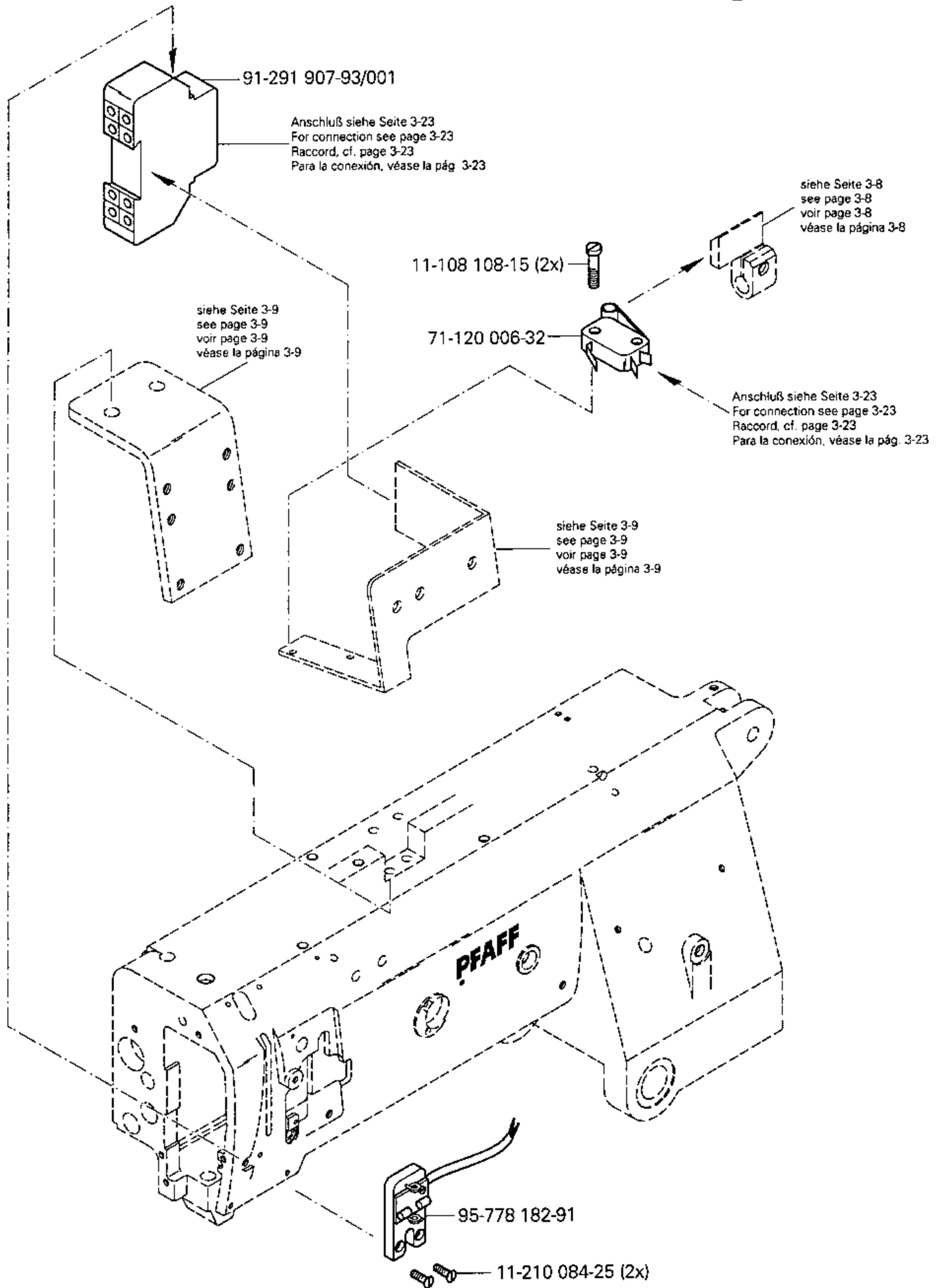
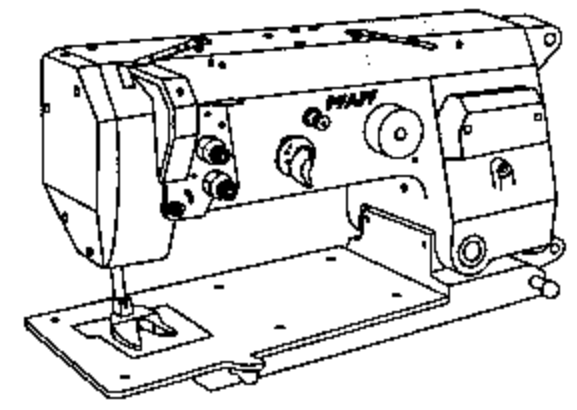

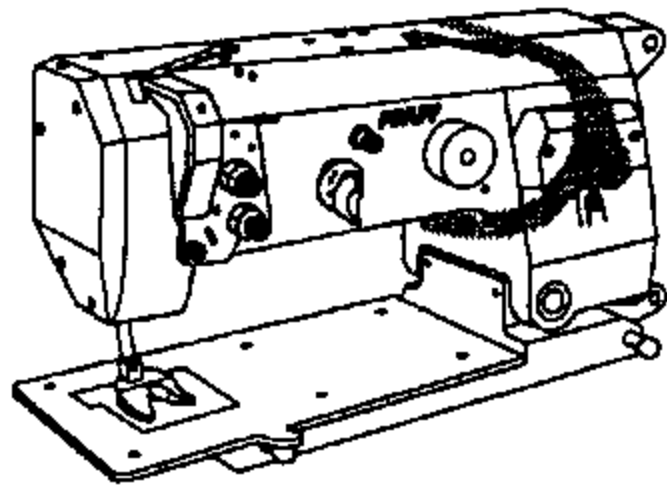

Armteile
 Arm parts
 Pièces de bras
 Piezas del brazo PFAFF 3588-04/020

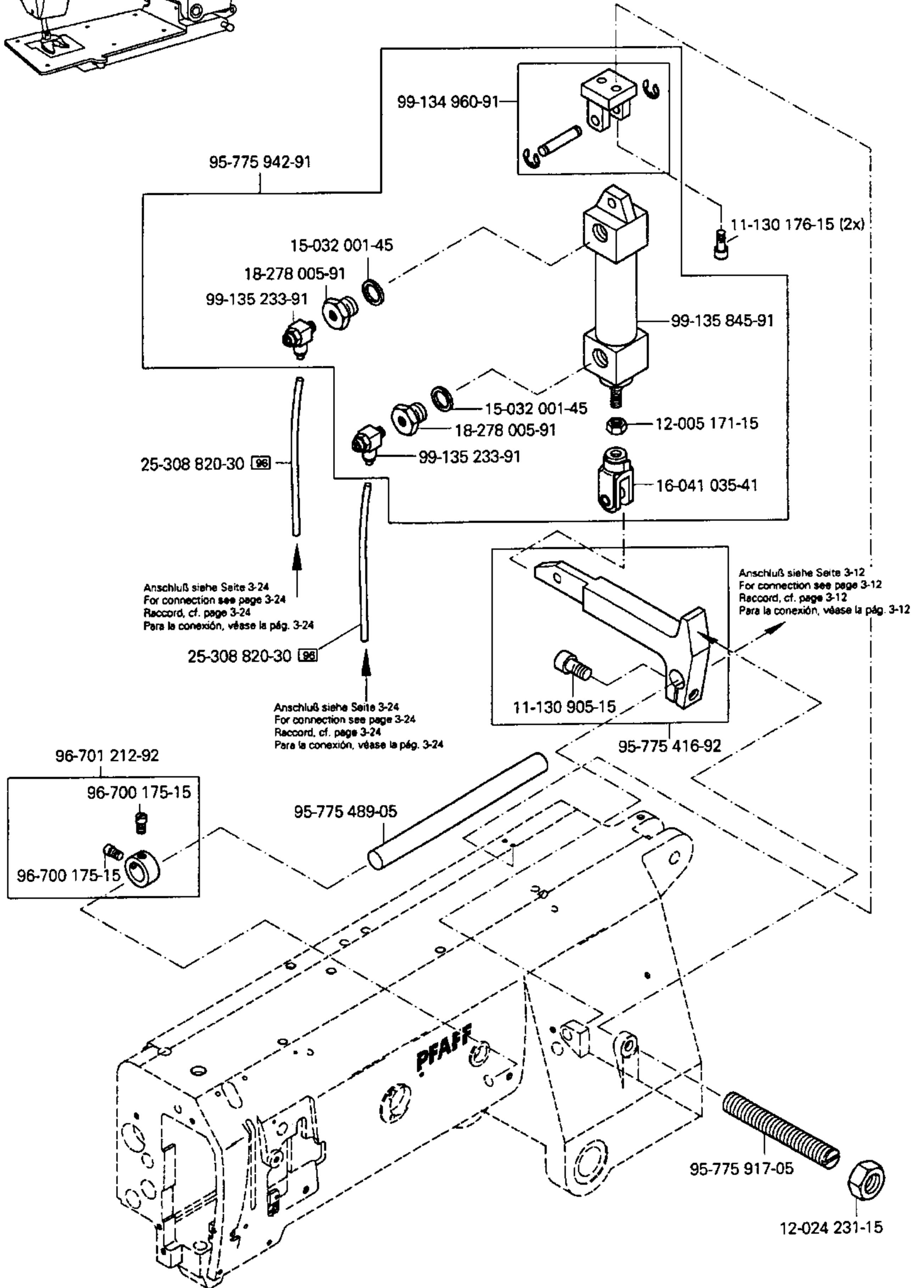

3.03

Armteile
 Arm parts
 Pièces de bras
 Piezas del brazo PFAFF 3588-04/020

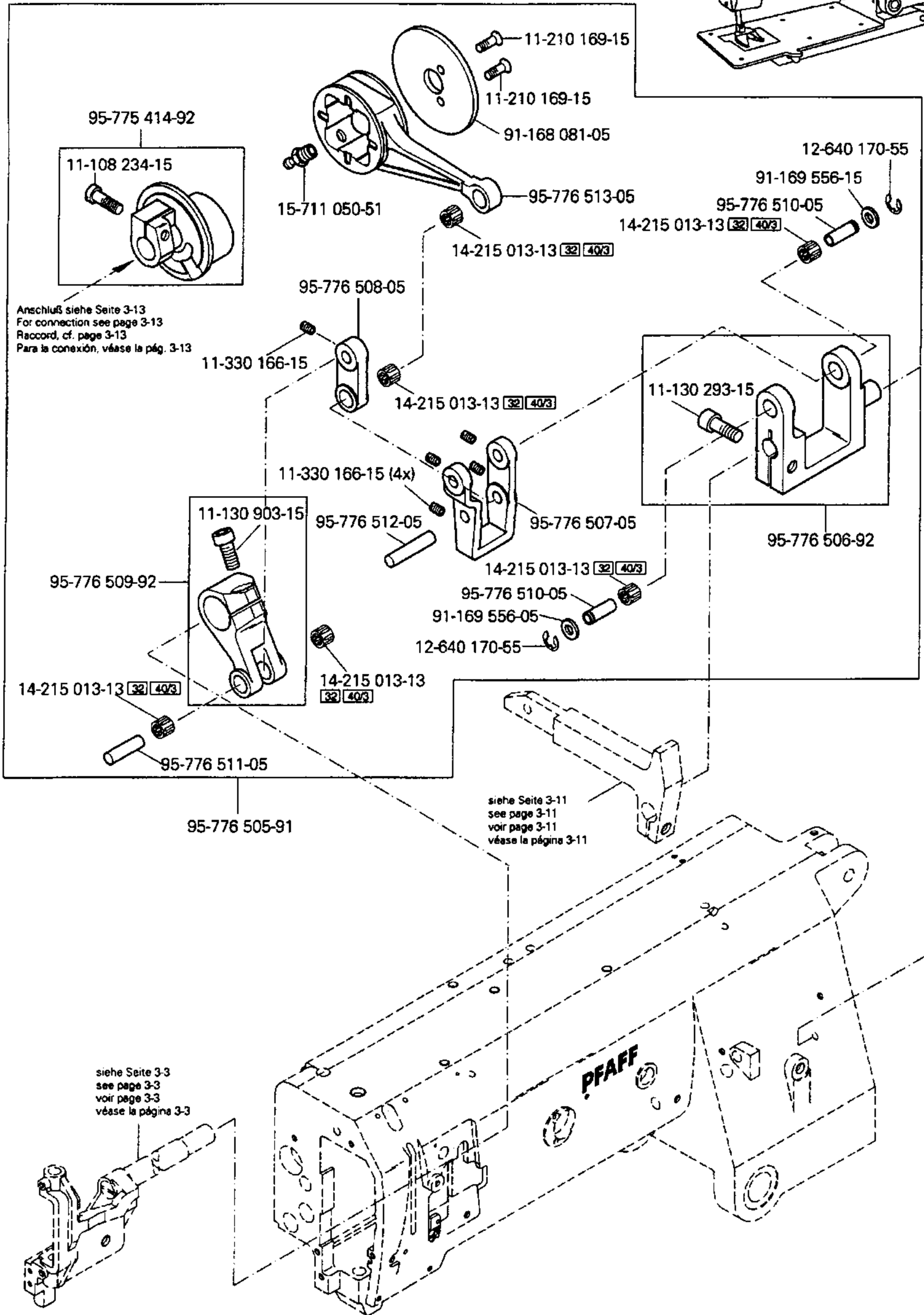
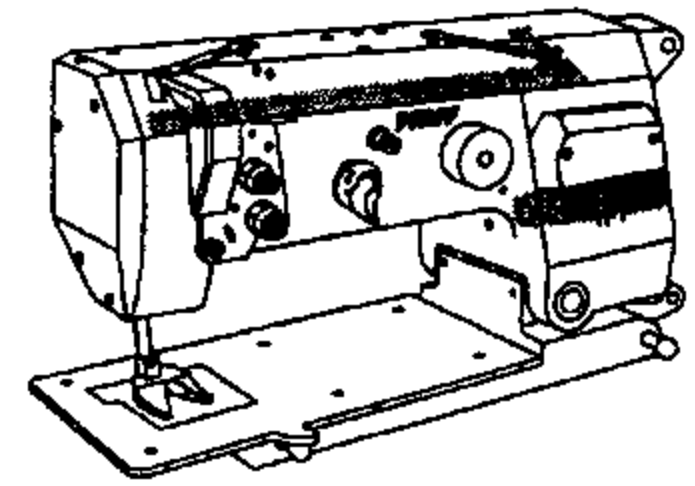

3.03

Armteile
 Arm parts
 Pièces de bras
 Piezas del brazo PFAFF 3588-04/020

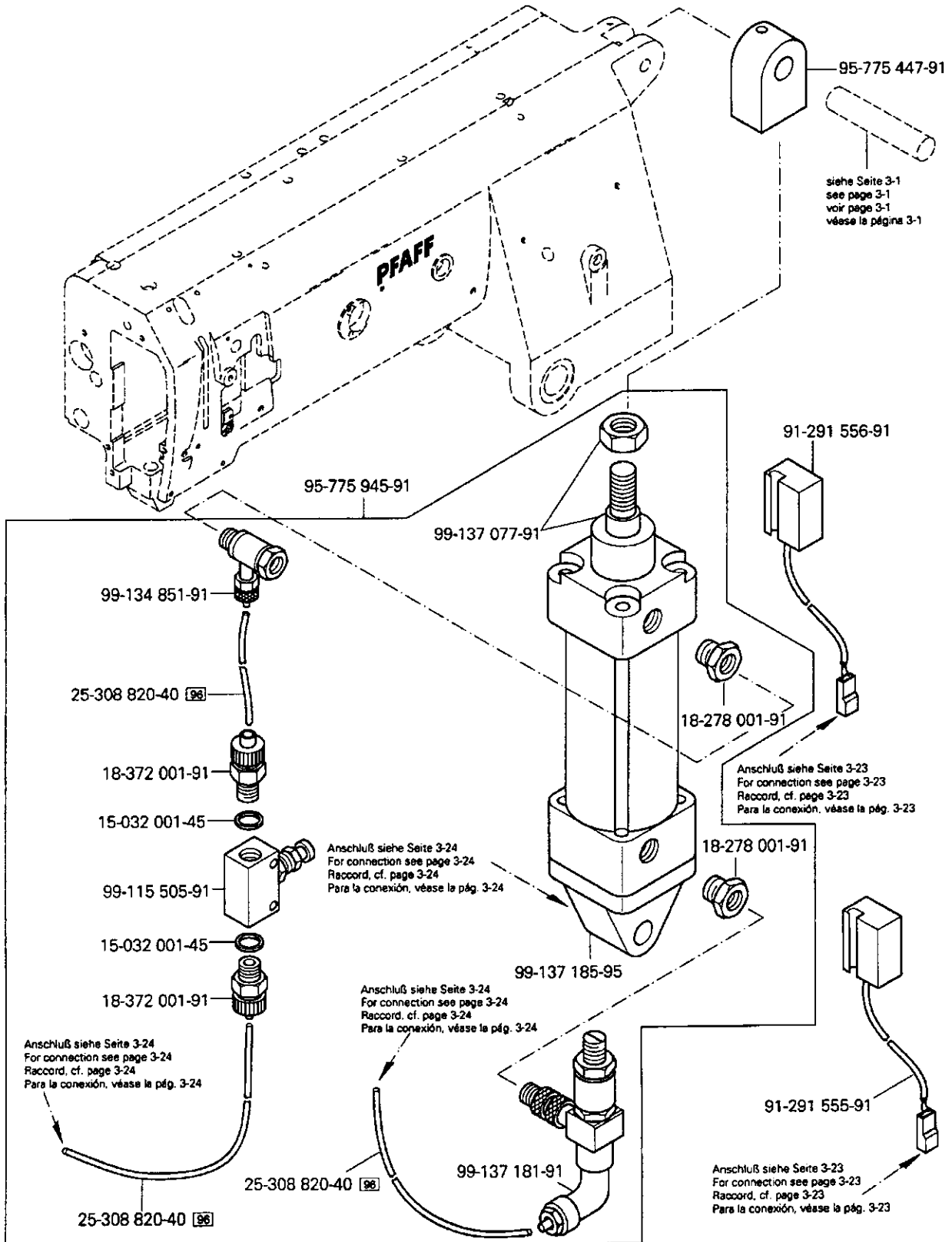
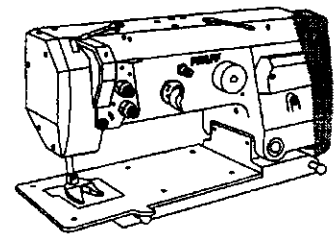

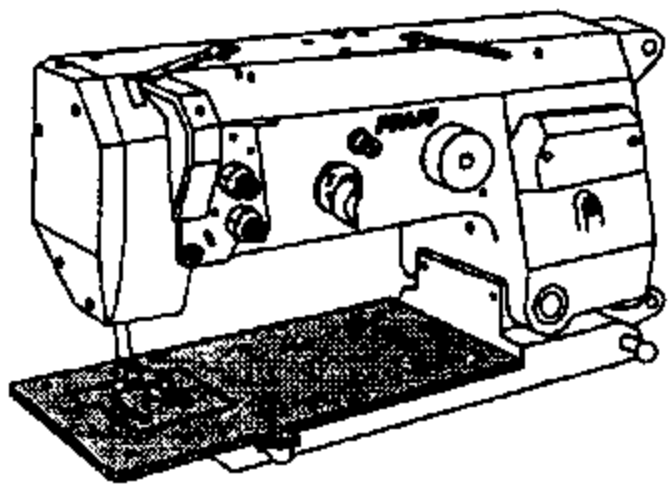

Grundplattenteile
 Bedplate parts
 Pièces du plateau fondamental
 Piezas del cárter

PFAFF 3588-04/020

3.04

Cover screw # 11-210 078-25 is a M3 x 5 MM. countersunk screw.
 #11-225 091-15 is the same screw except allen head.

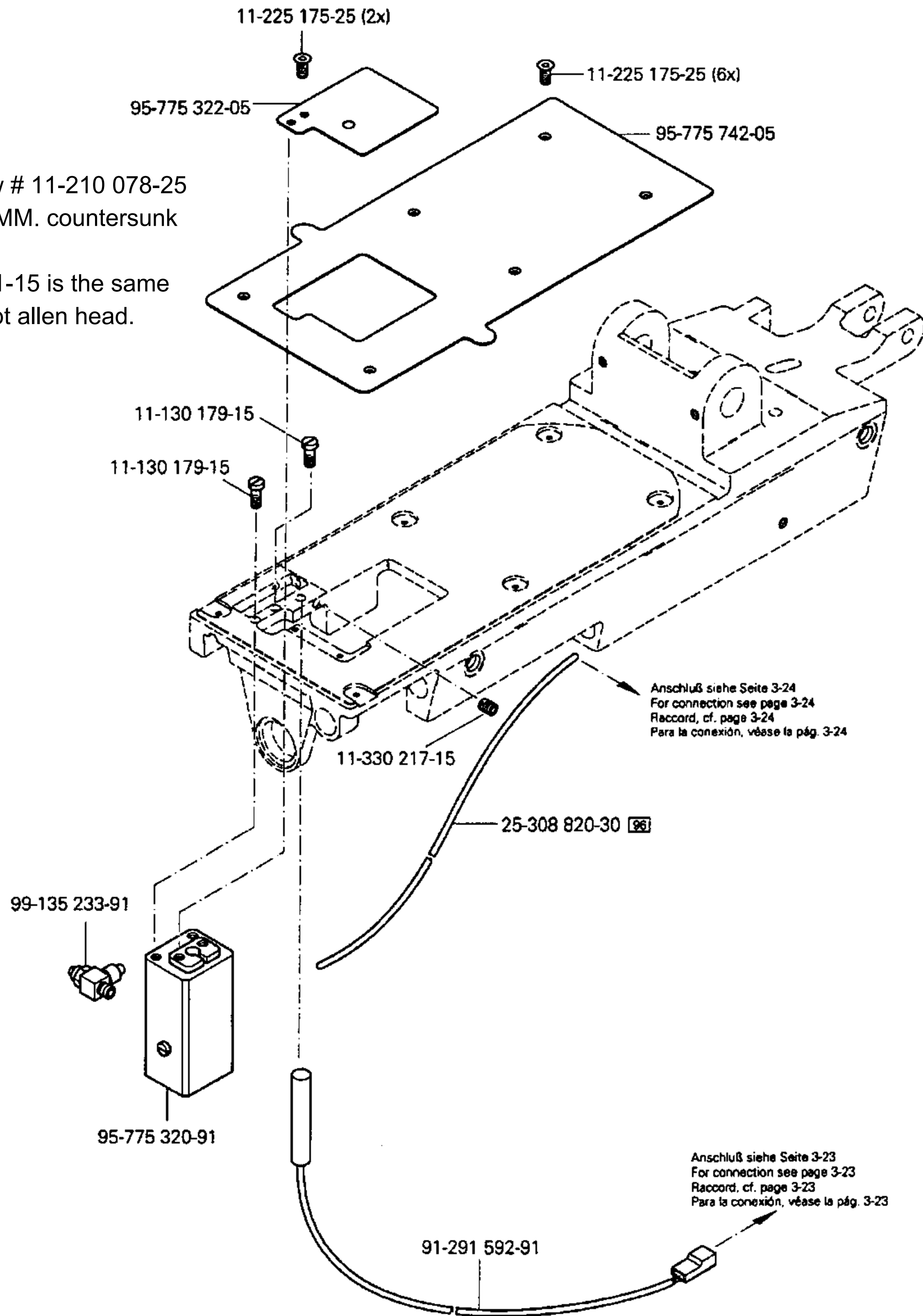

3.04

Grundplattenteile
 Bedplate parts
 Pièces du plateau fondamental
 Piezas del cárter

PFAFF 3588-04/020

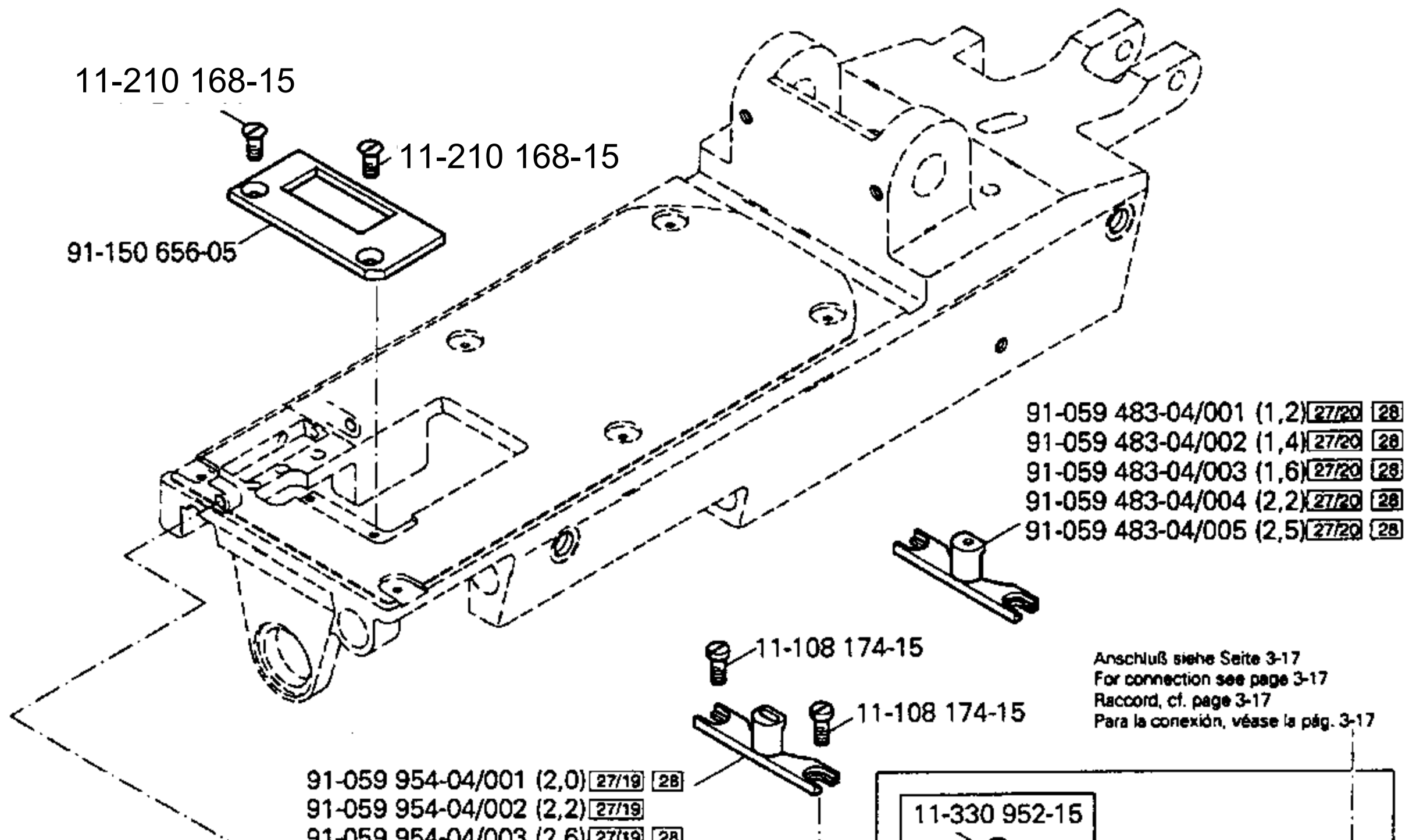
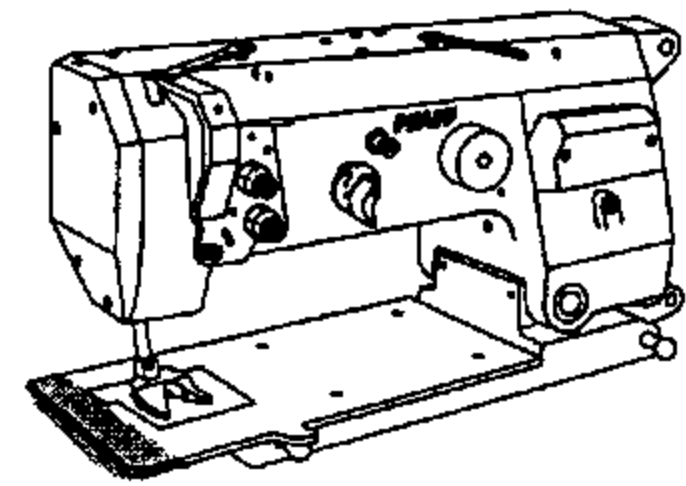

Anschluß siehe Seite 3-17
 For connection see page 3-17
 Raccord, cf. page 3-17
 Para la conexión, véase la pág. 3-17

Counter press number 91-059 954-04/005 is a
 1.6 MM. needle hole.

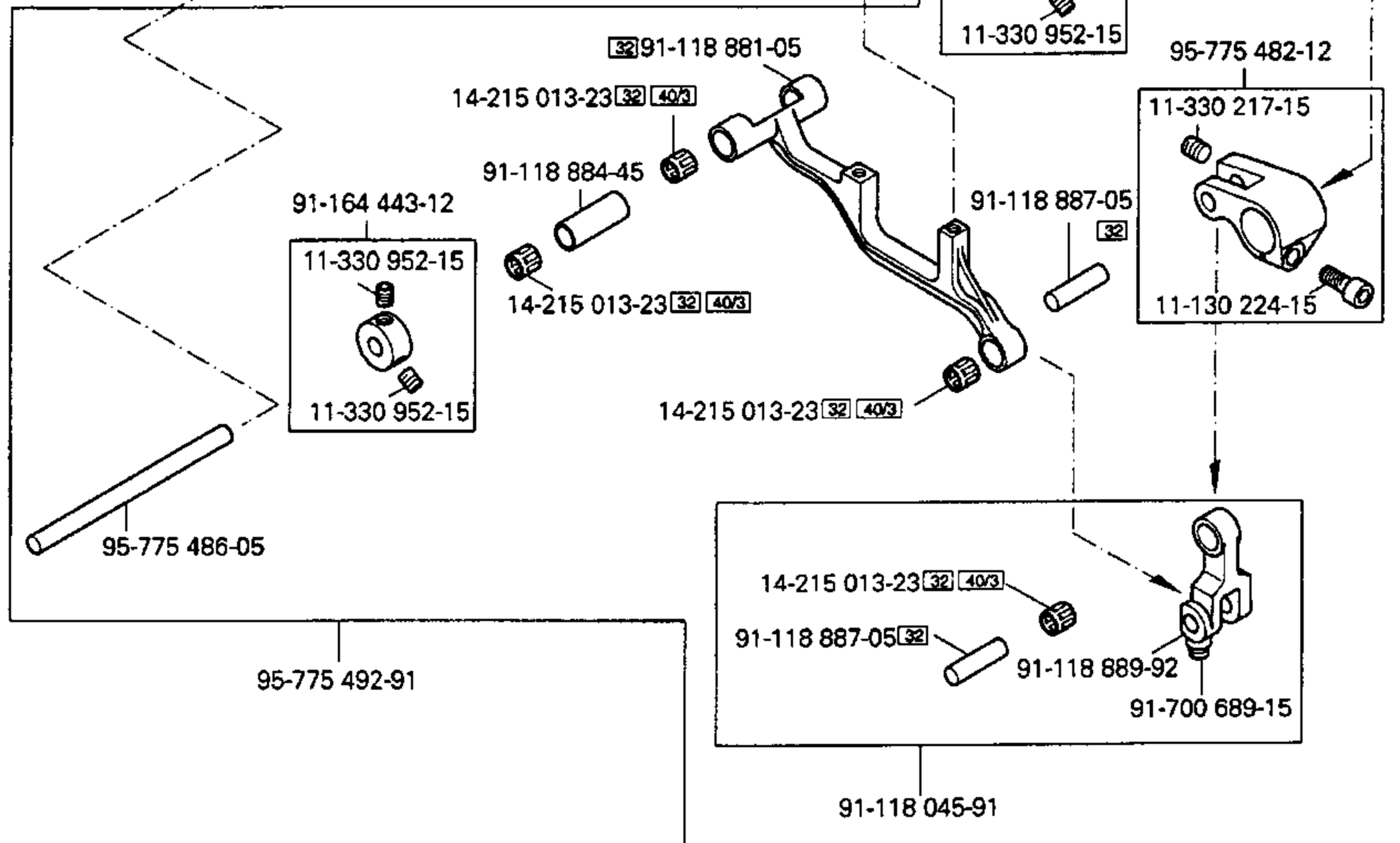

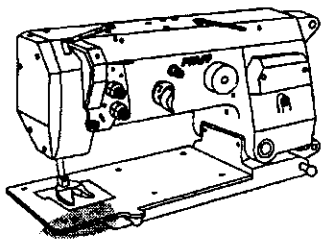

Grundplattenteile
 Bedplate parts
 Pièces du plateau fondamental
 Piezas del cárter

PFAFF 3588-04/020

3.04

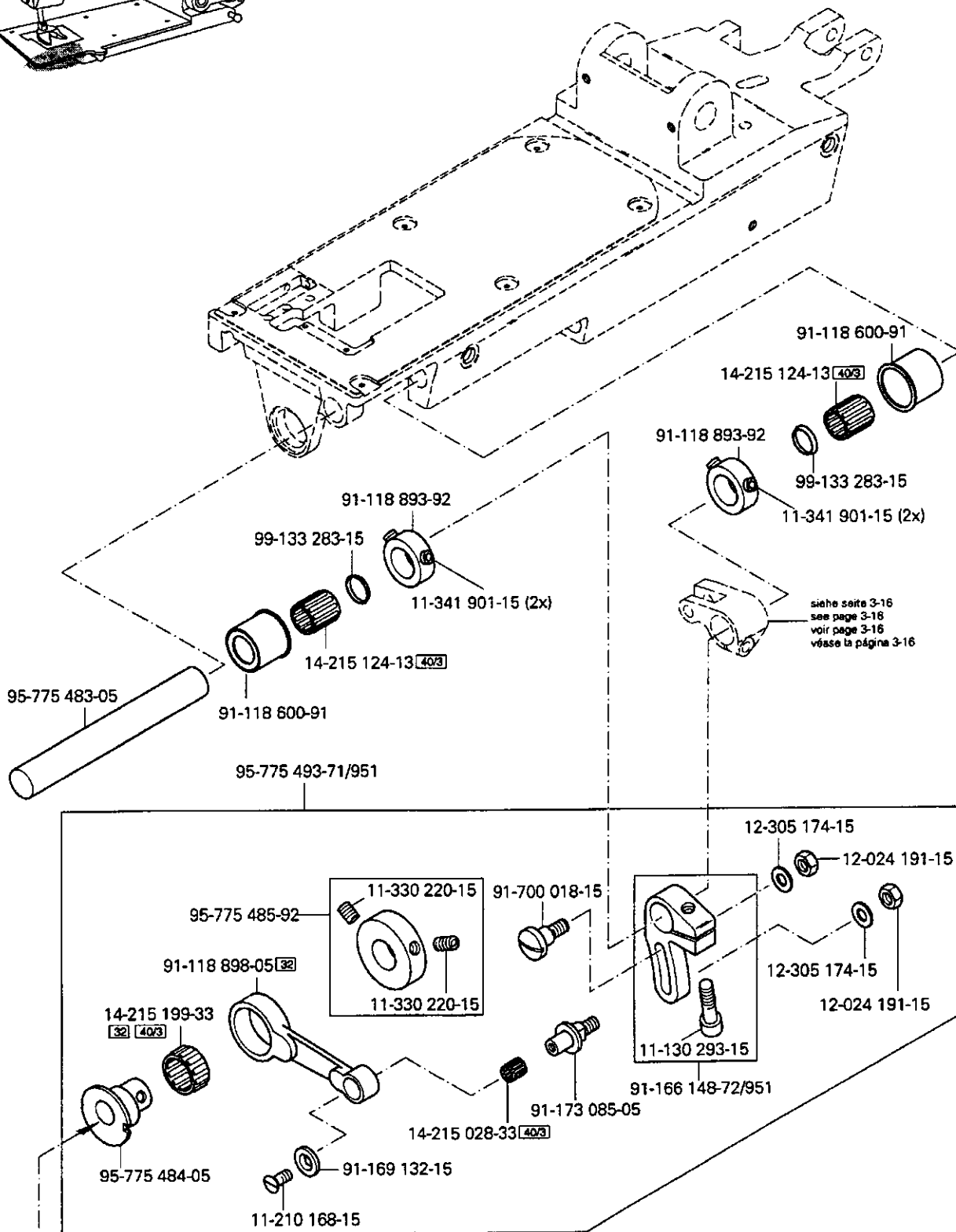

Anschluß siehe Seite 3-18
 For connection see page 3-18
 Raccord, cf. page 3-18
 Para la conexión, véase la pág. 3-18

PFAFF

☐ siehe Kapitel 2 Erläuterung der Schlüsselzeichen
 see chapter 2 Explanation of key markings
 voir le chap. 2 Explication des symboles
 véase el Cap. 2 Explicaciones de los signos clave

3.04

Grundplattenteile Bedplate parts Pièces du plateau fondamental Piezas del cárter

PFAFF 3588-04/020

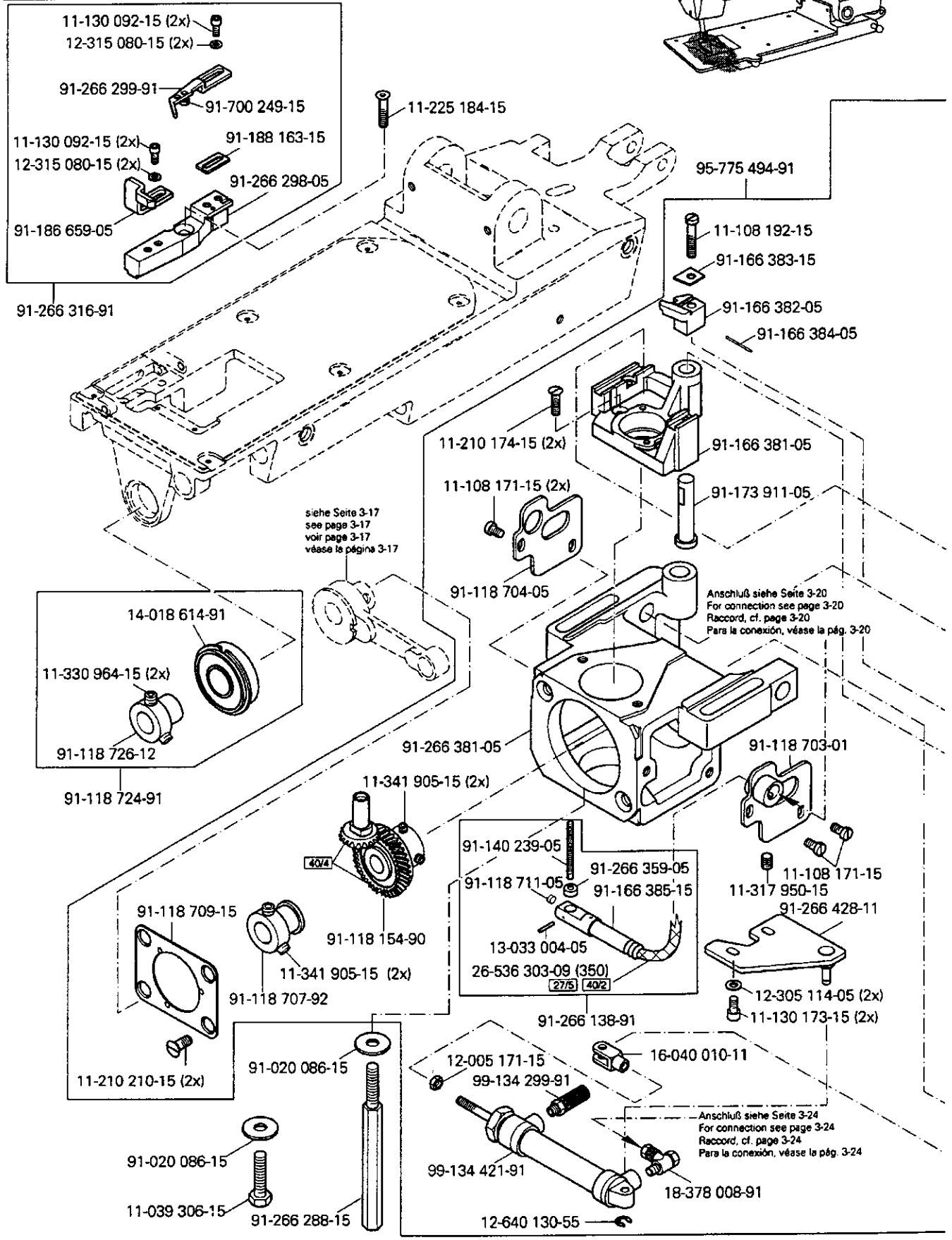
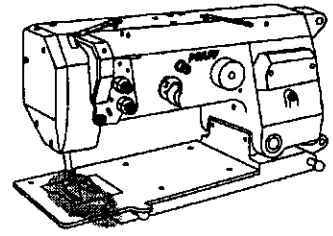

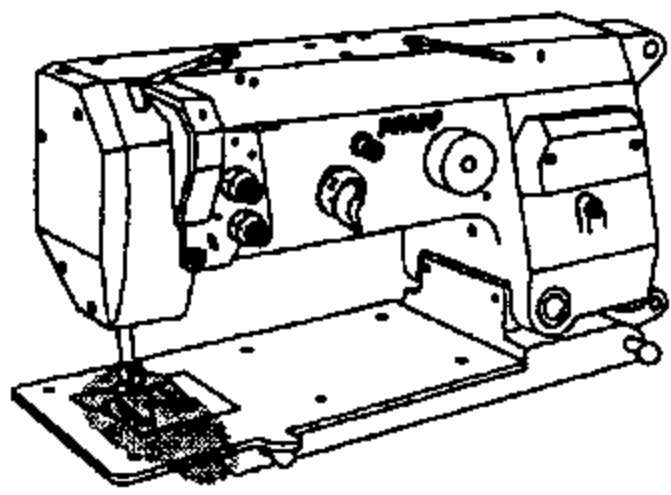

Grundplattenteile
Bedplate parts
Pièces du plateau fondamental
Piezas del cárter

PFAFF 3588-04/020

3.04

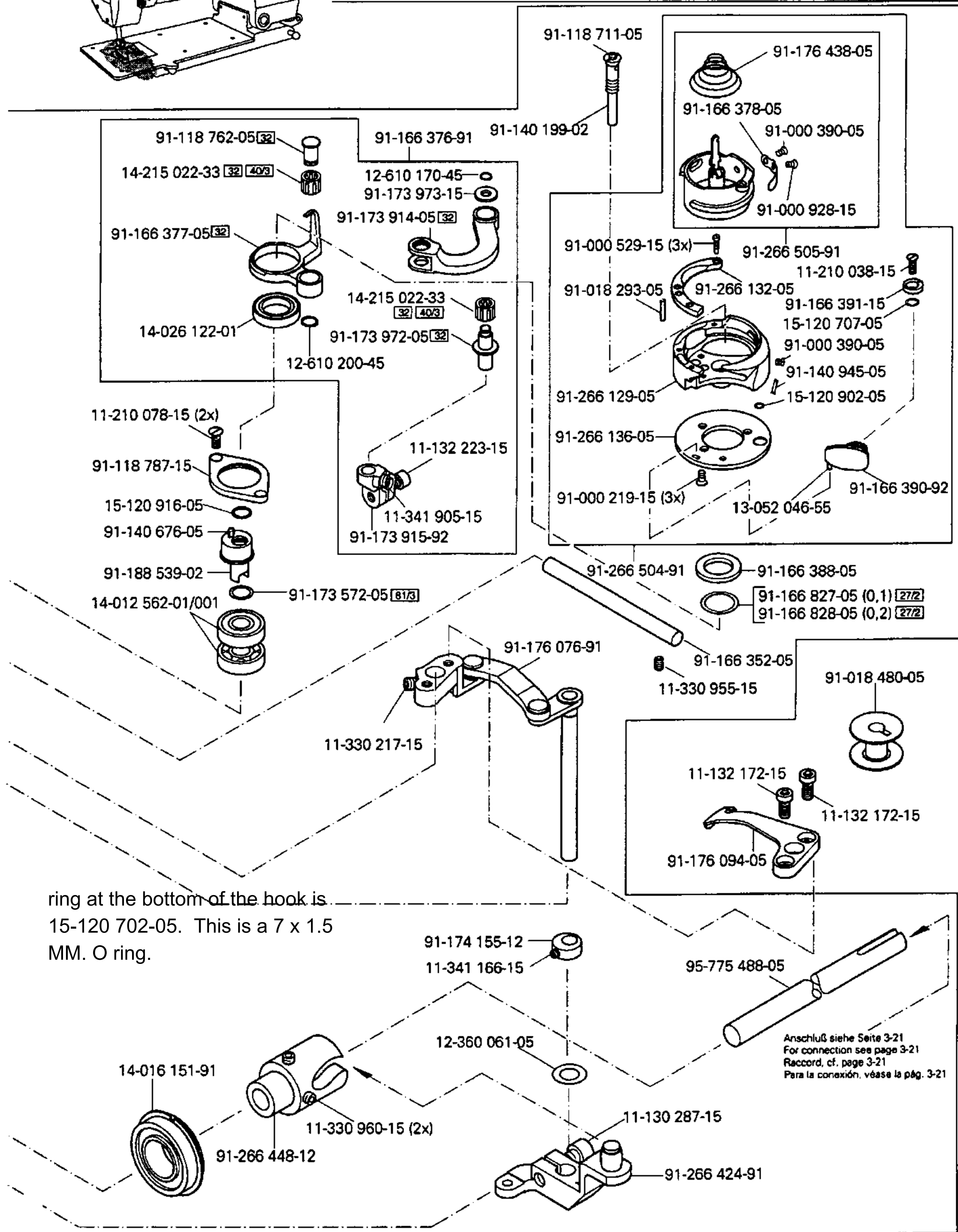

ring at the bottom of the hook is 15-120 702-05. This is a 7 x 1.5 MM. O ring.

Anschluß siehe Seite 3-21
For connection see page 3-21
Raccord, cf. page 3-21
Para la conexión, véase la pág. 3-21

PFAFF

☐ siehe Kapitel 2 Erläuterung der Schlüsselzeichen
see chapter 2 Explanation of key markings
voir le chap. 2 Explication des symboles
véase el Cap. 2 Explicaciones de los signos clave

ring at the bottom of the hook is 15-120 702-05. This is a 7 x 1.5 MM. O ring.

3.04

Grundplattenteile
Bedplate parts
Pièces du plateau fondamental
Piezas del cárter

PFAFF 3588-04/020

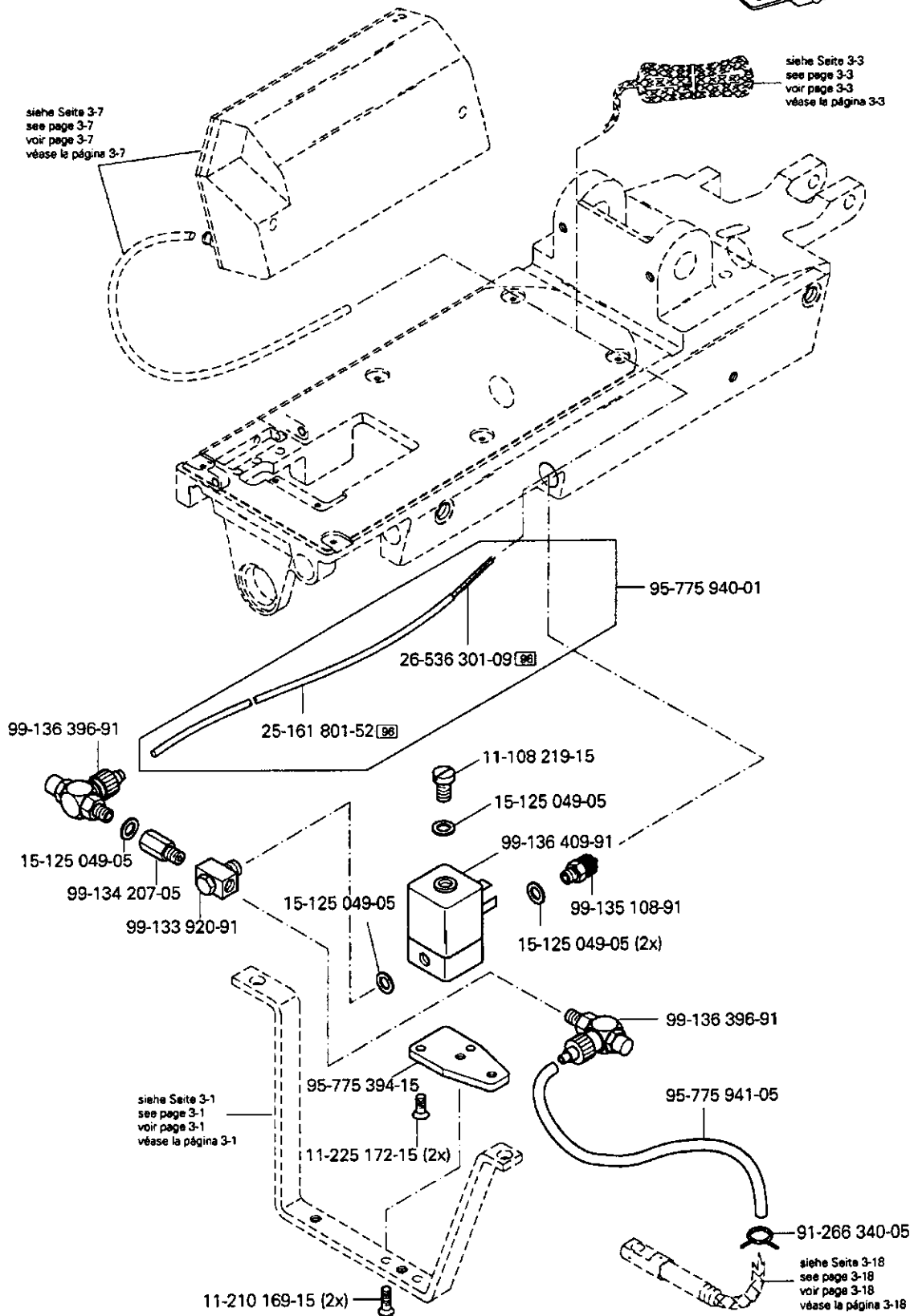
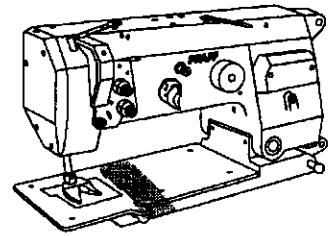

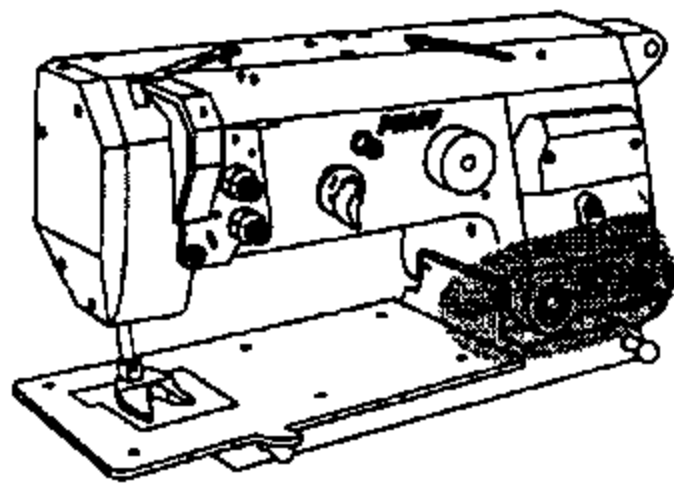

Grundplattenteile
Bedplate parts
Pièces du plateau fondamental
Piezas del cárter

PFAFF 3588-04/020

3.04

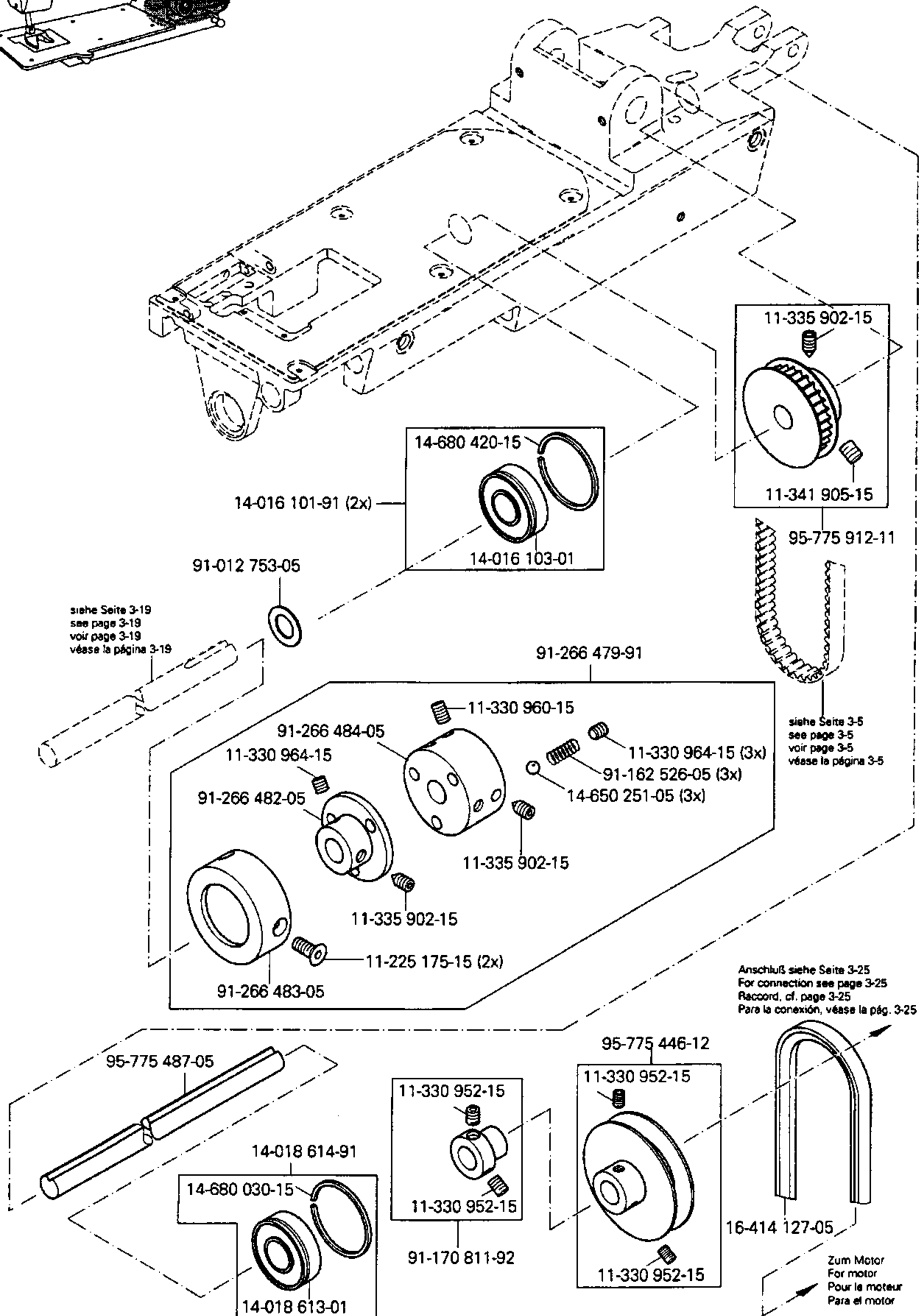

3.04

Grundplattenteile
 Bedplate parts
 Pièces du plateau fondamental
 Piezas del cárter

PFAFF 3588-04/020

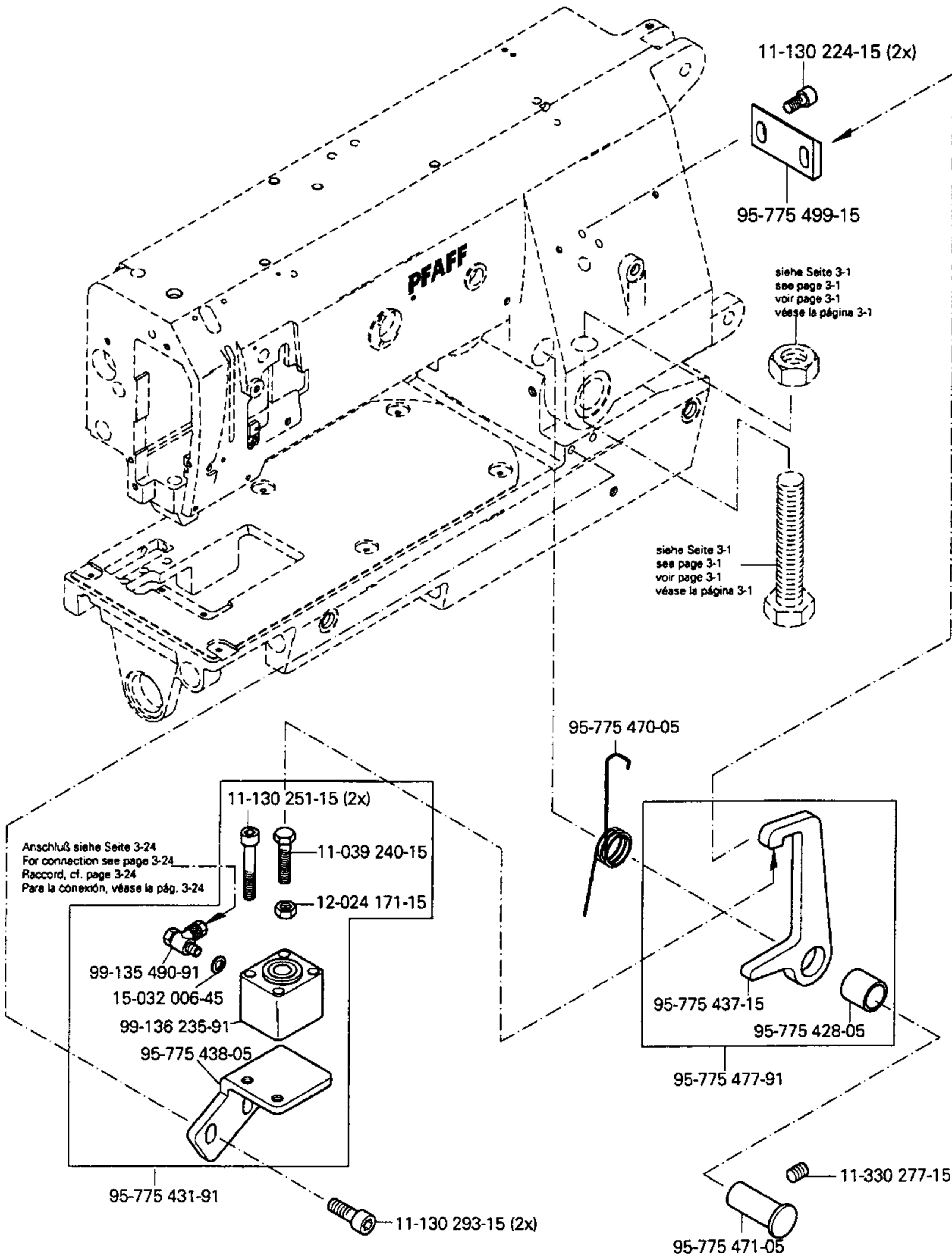
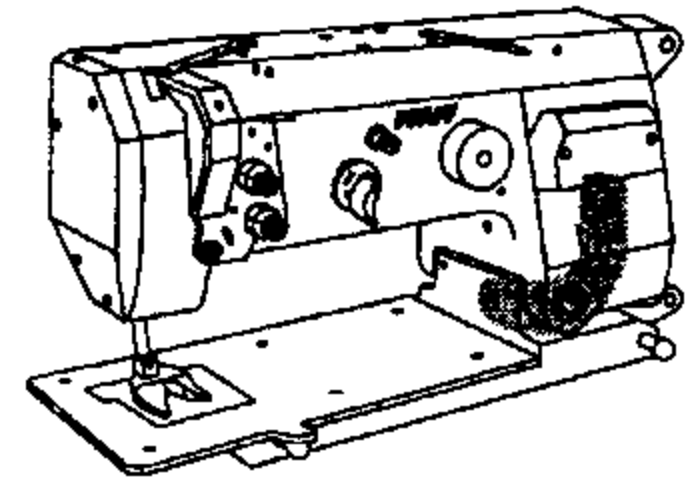

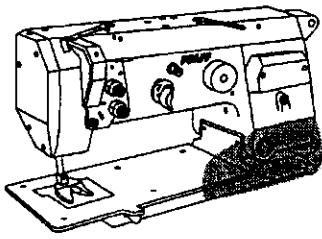

Grundplattenteile
Bedplate parts
Pièces du plateau fondamental
Piezas del cárter

PFAFF 3588-04/020

3.04

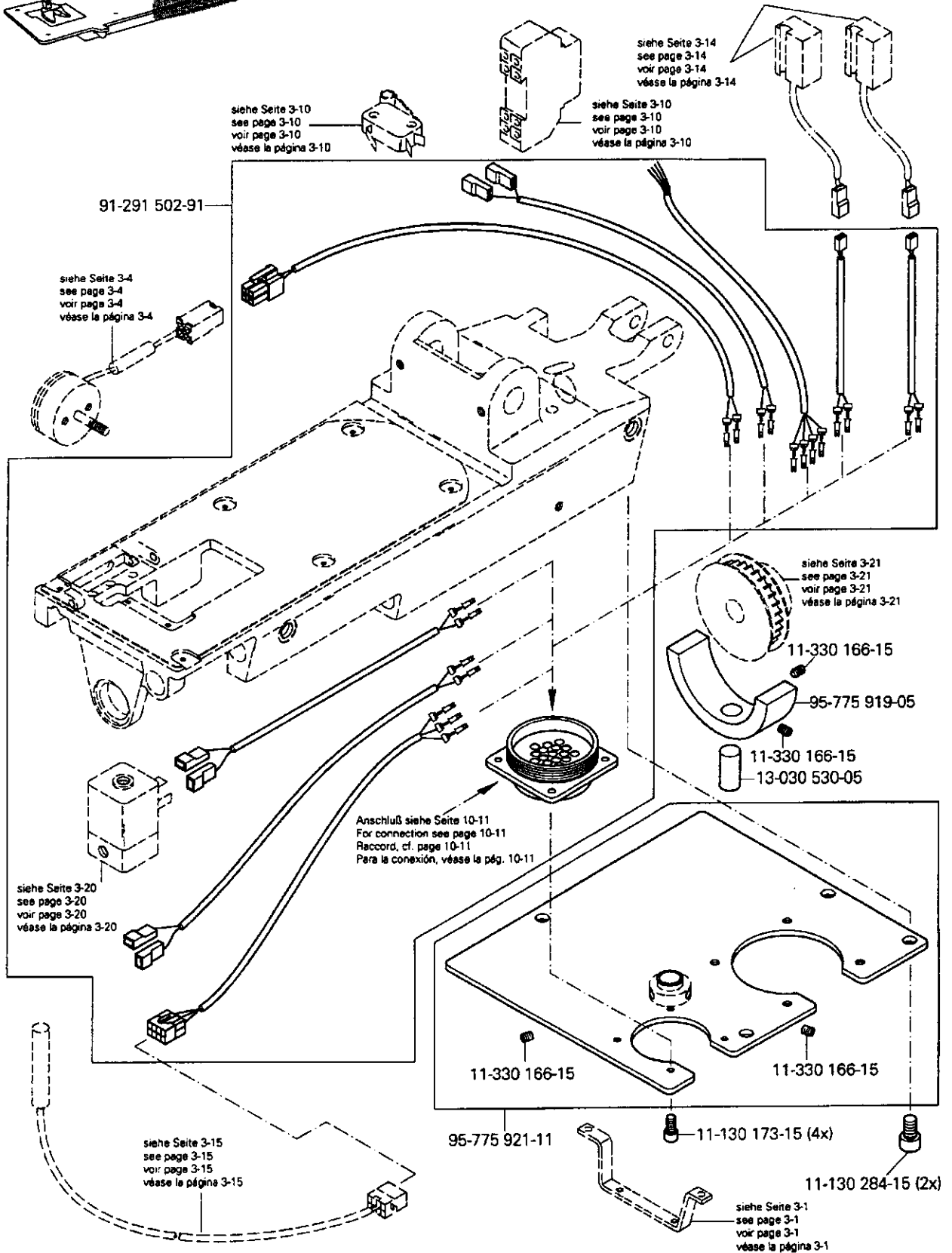

3.04

Grundplattenteile Bedplate parts Pièces du plateau fondamental Piezas del cárter

PFAFF 3588-04/020

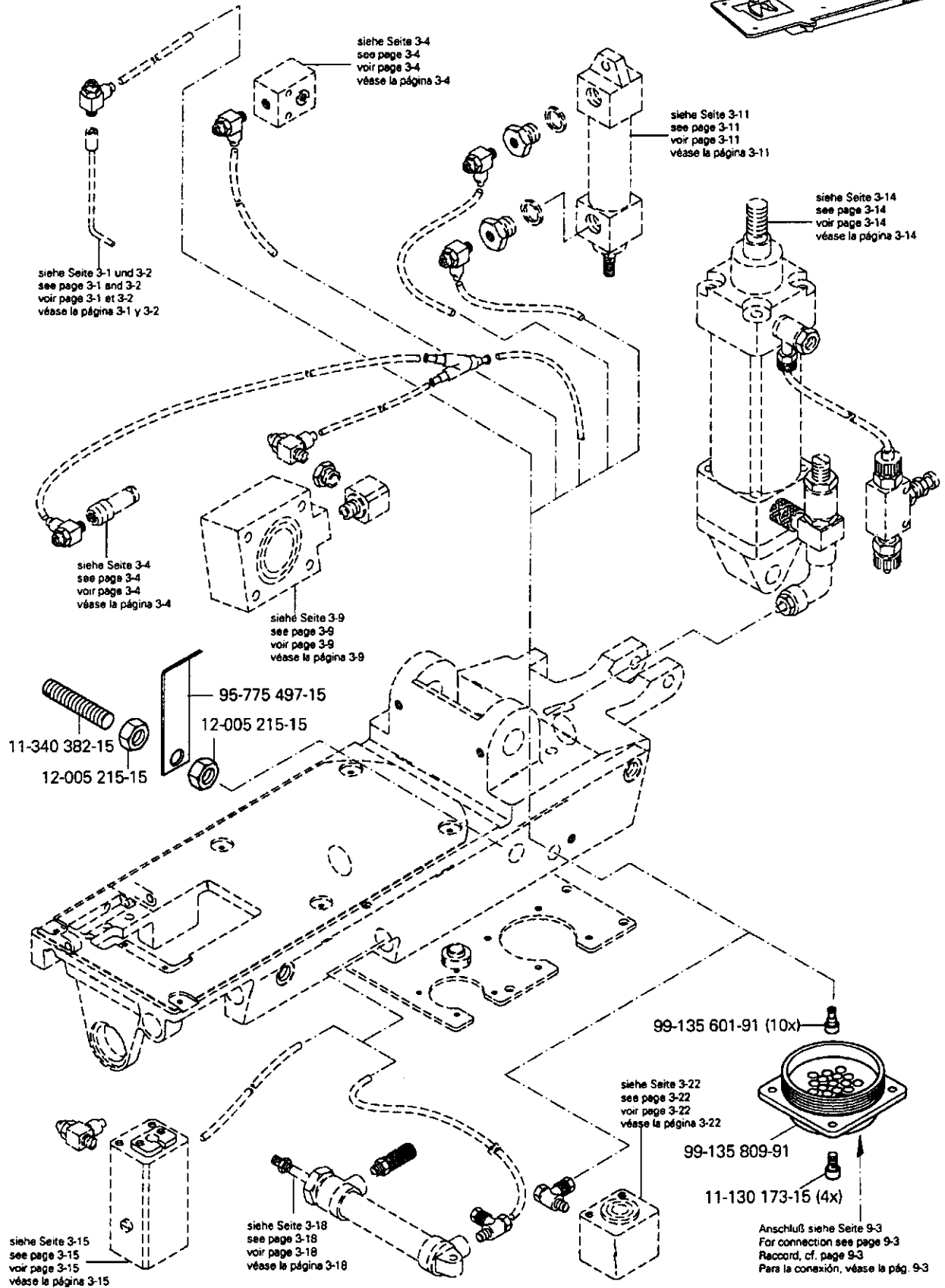
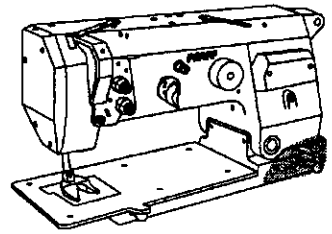

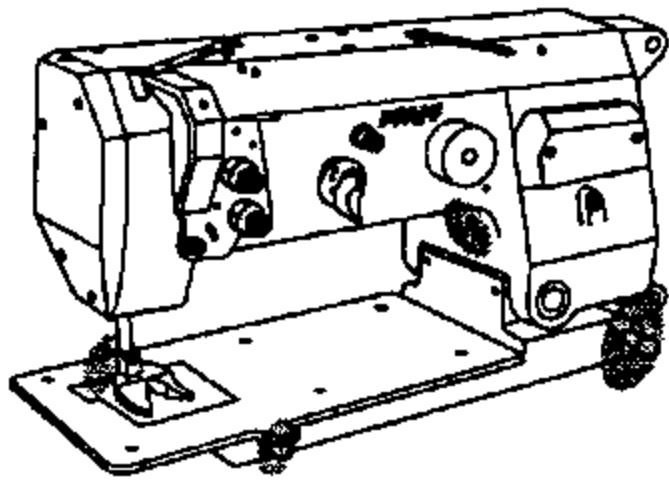

Grundplattenteile
 Bedplate parts
 Pièces du plateau fondamental
 Piezas del cárter

PFAFF 3588-04/020

3.04

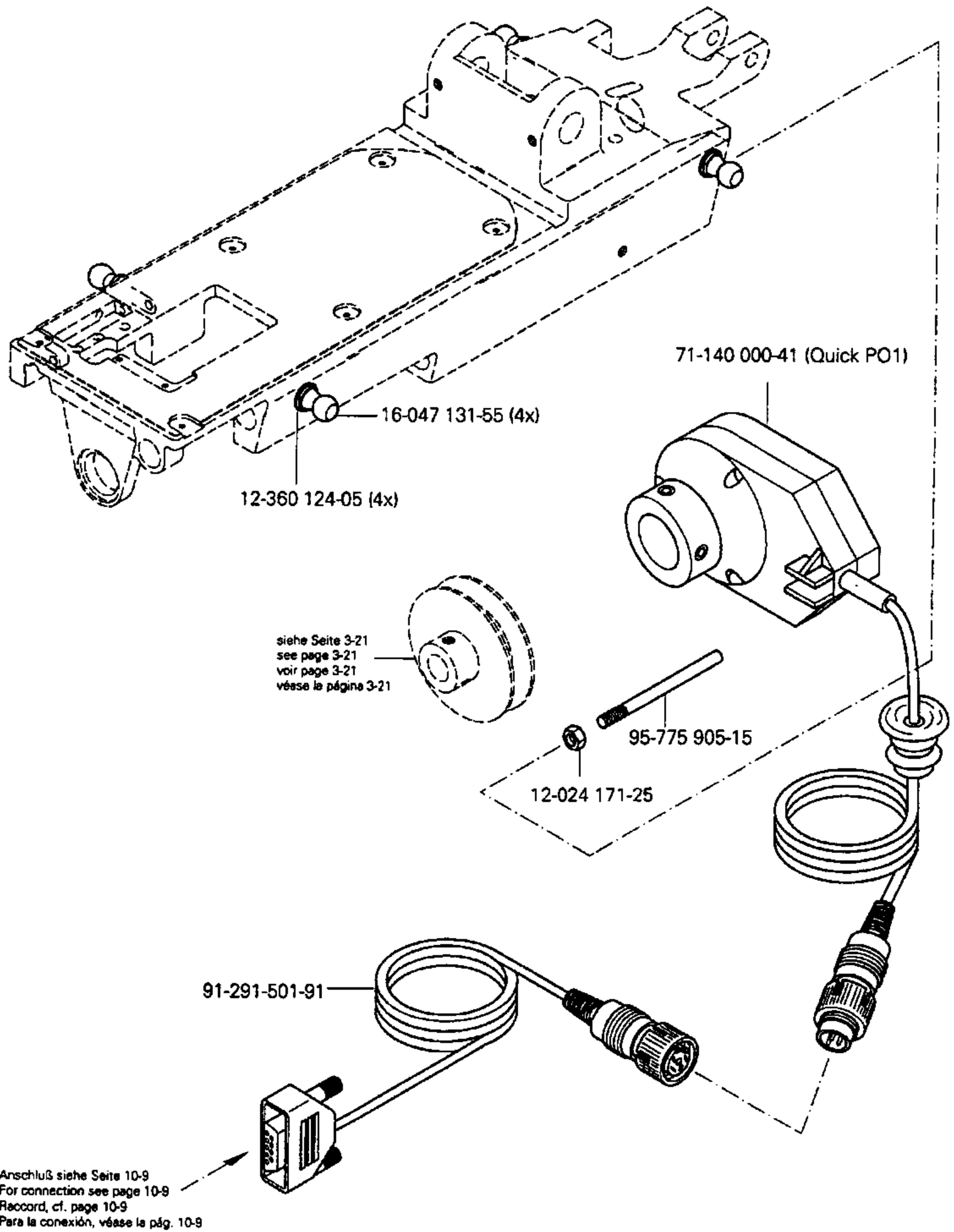

4

Tischplatte
 Table top
 Plateau de table
 Tablero de costura PFAFF 3588-04/020

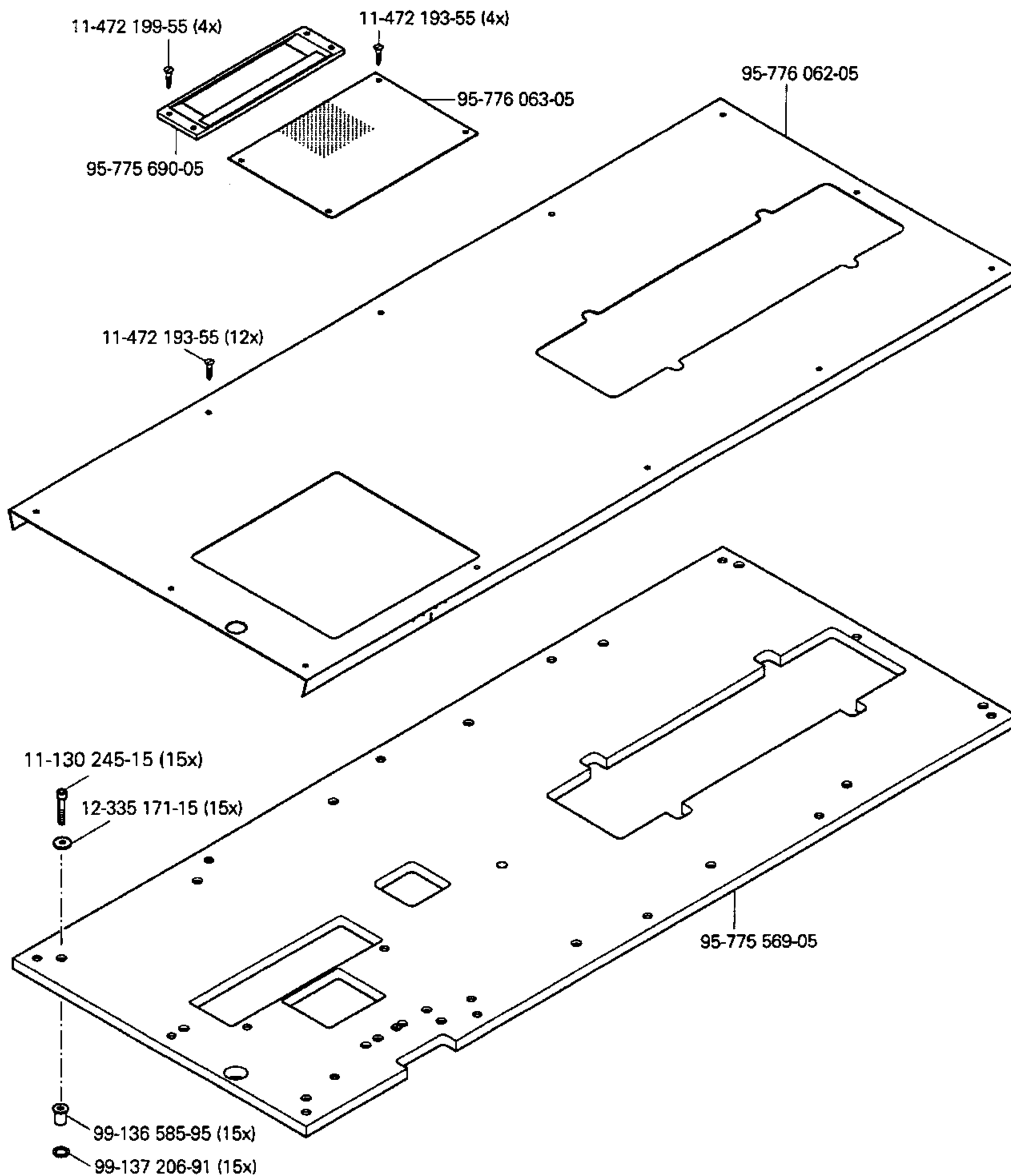
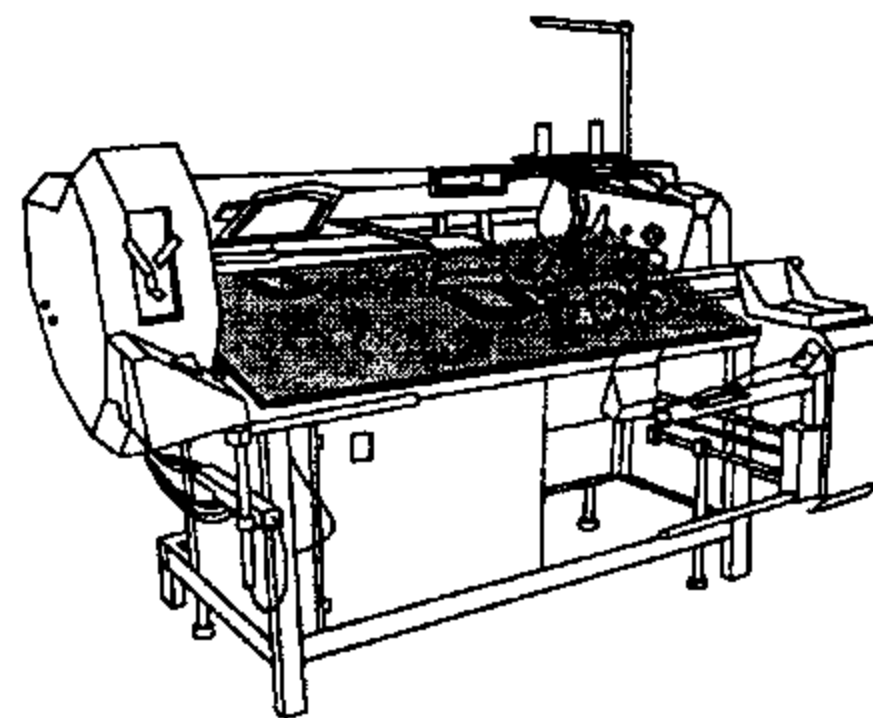

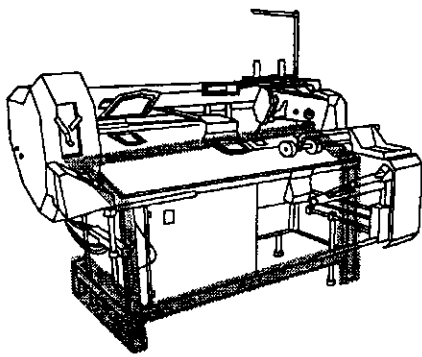

Gestell mit Anbauteilen
 Stand with assembly parts
 Bâti avec éléments de montage
 Bancada con piezas de montaje PFAFF 3588-04/020

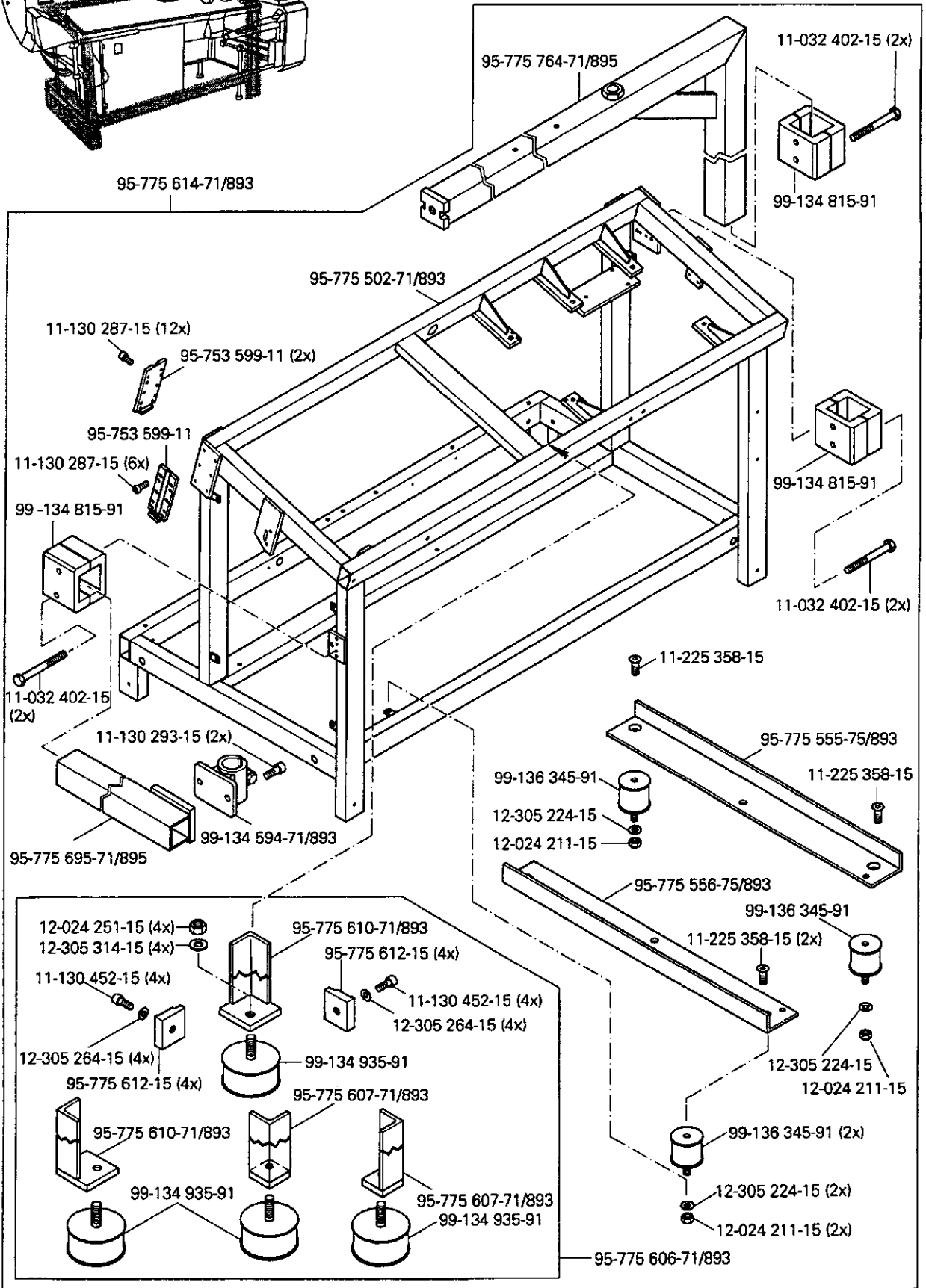

5

Gestell mit Anbauteilen
 Stand with assembly parts
 Bâti avec éléments de montage
 Bancada con piezas de montaje PFAFF 3588-04/020

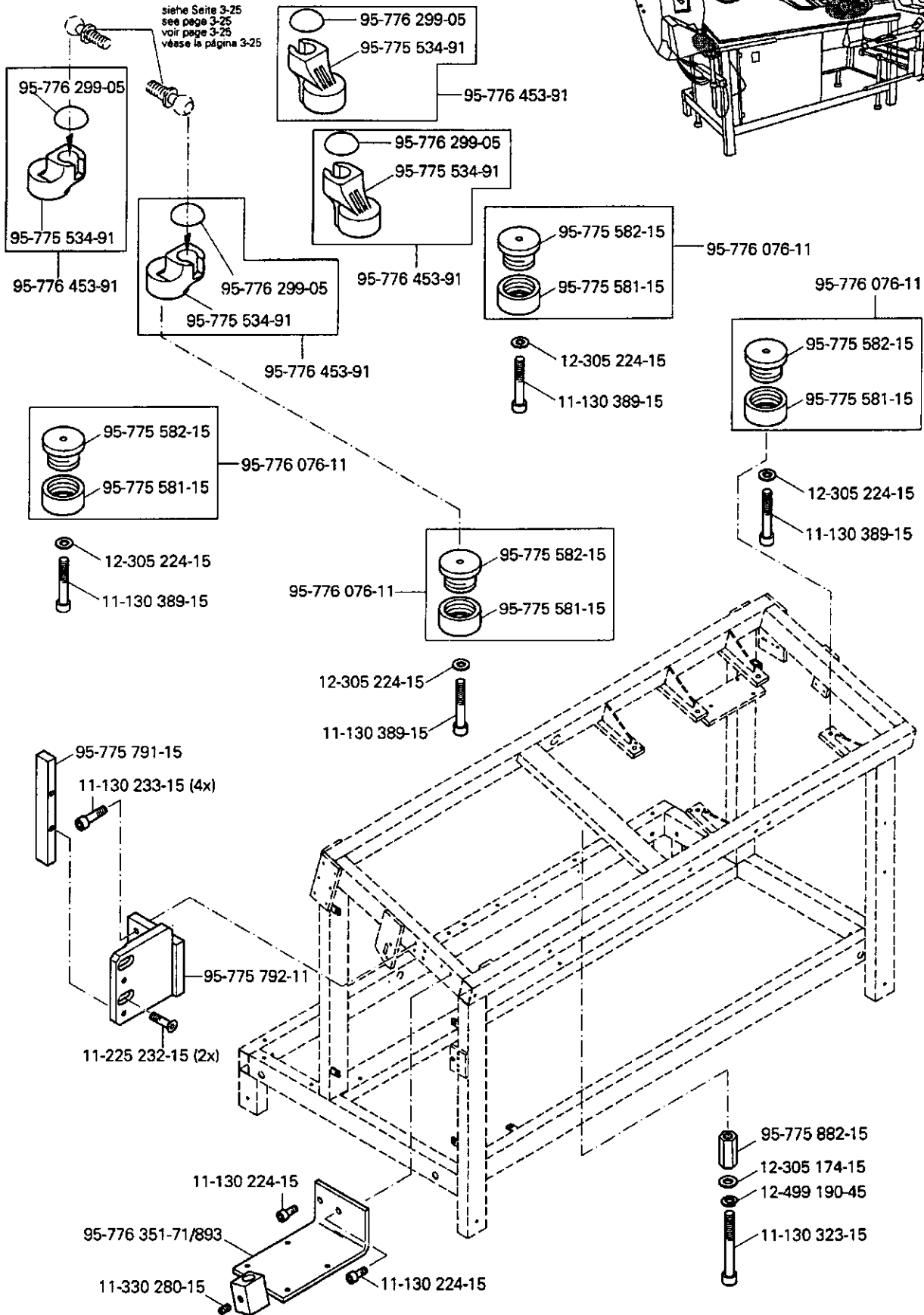
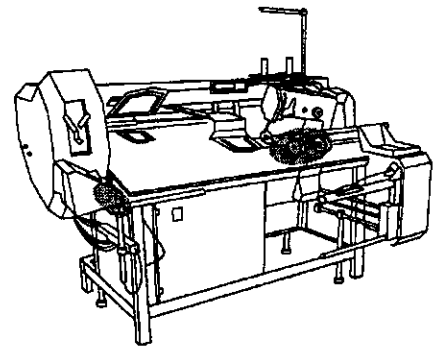

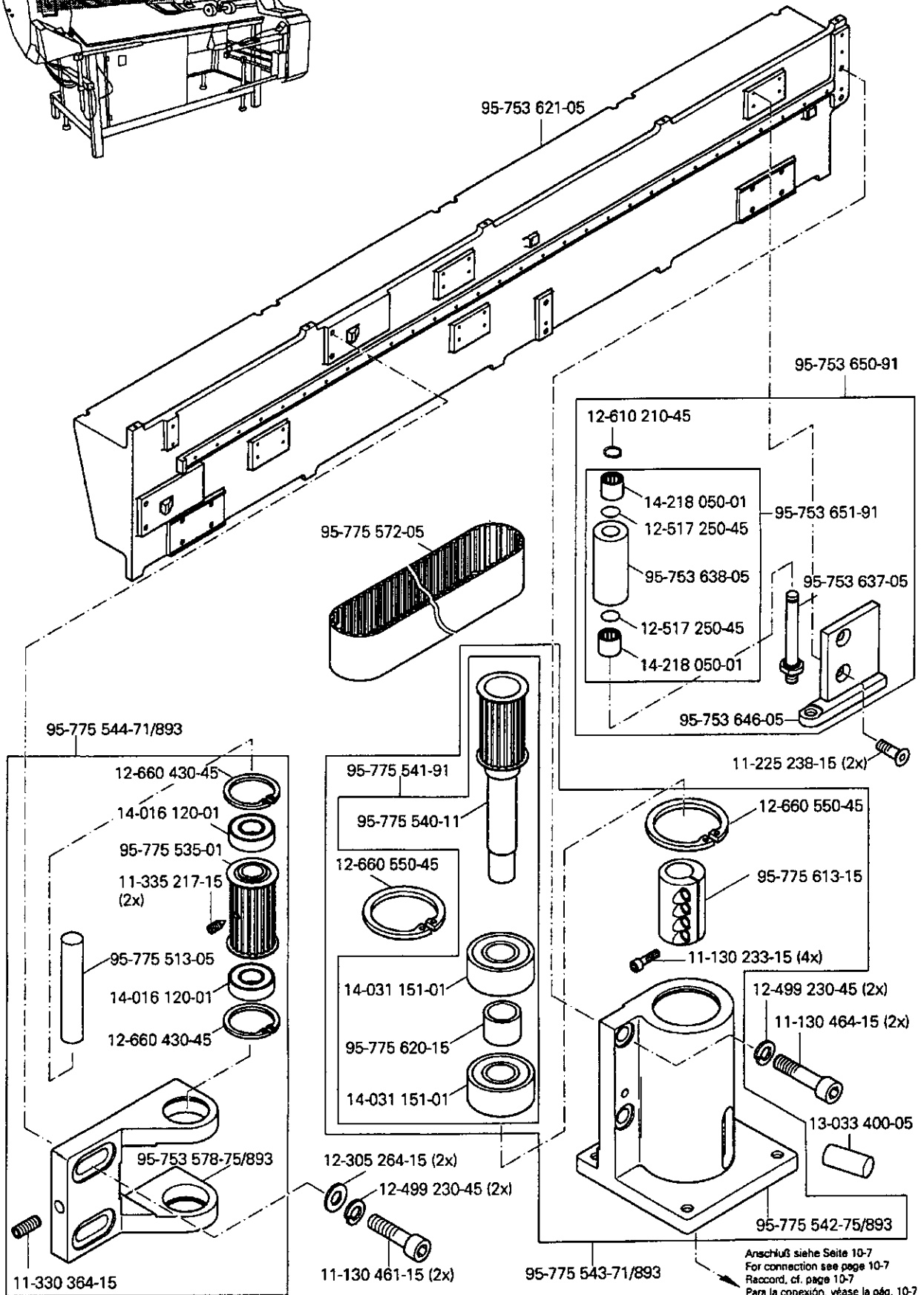
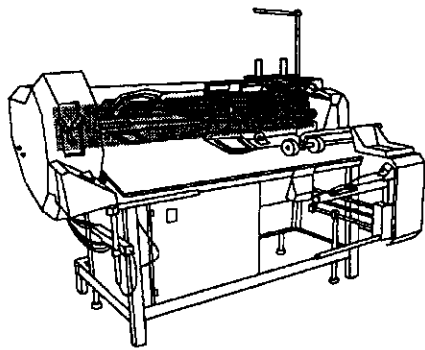

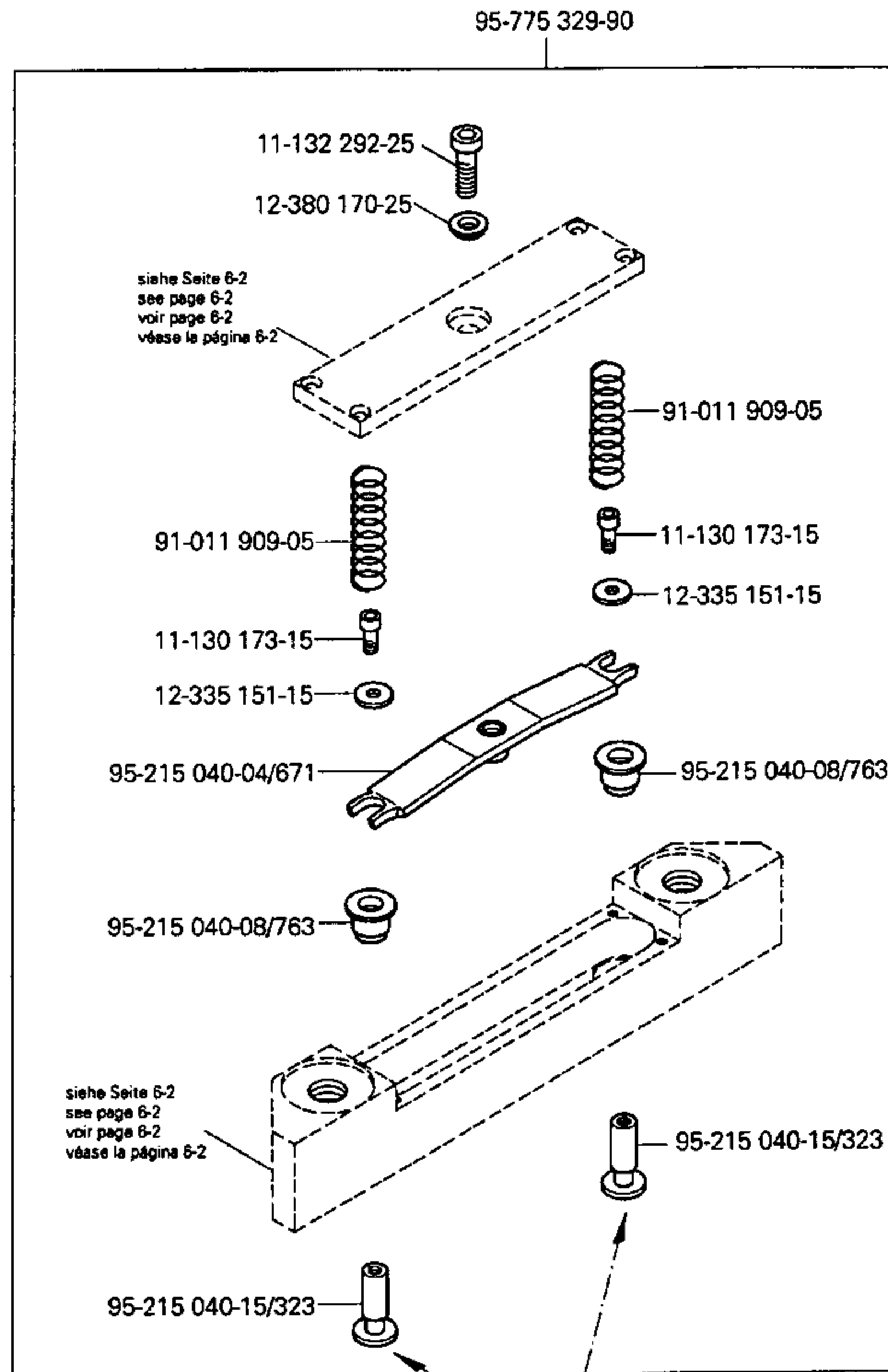
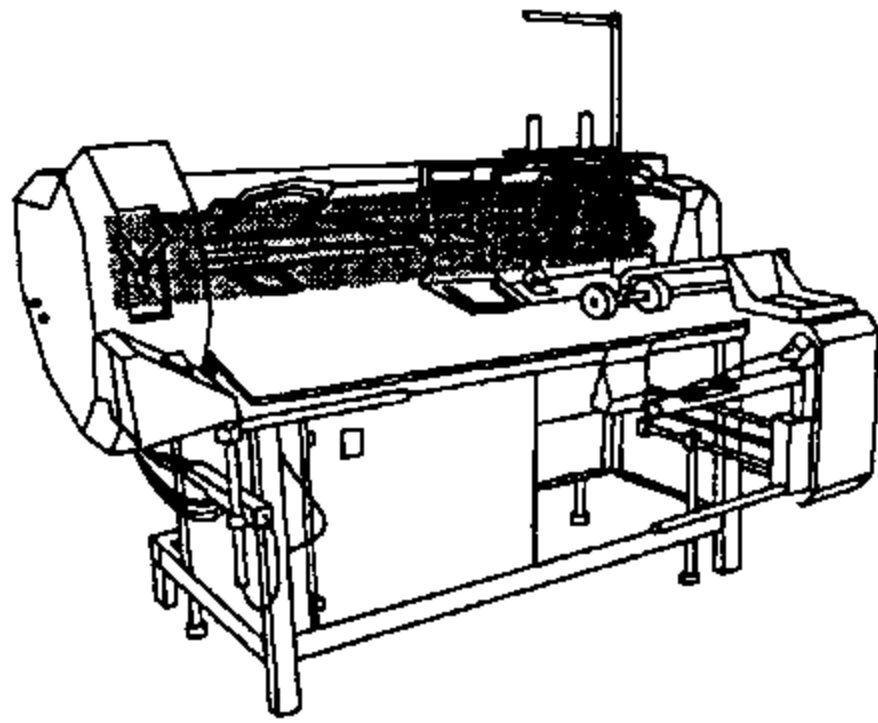

Anschluß siehe Seite 15-14
 For connection see page 15-14
 Raccord, cf. page 15-14
 Para la conexión, véase la pág. 15-14

6

X-Y-Antrieb
 X-Y drive
 Système de commande X-Y
 Grupo de accionamiento "X-Y" PFAFF 3588-04/020

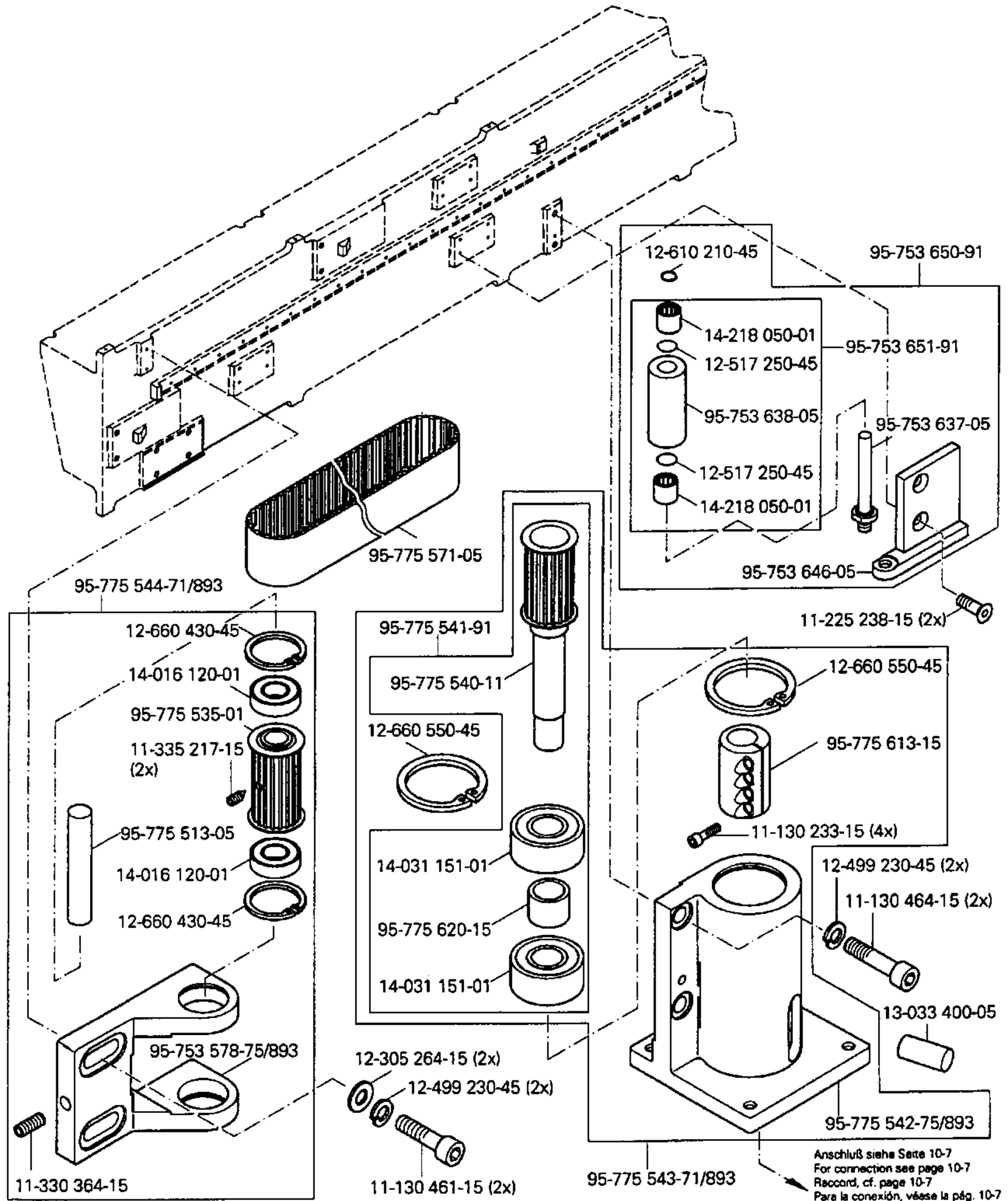
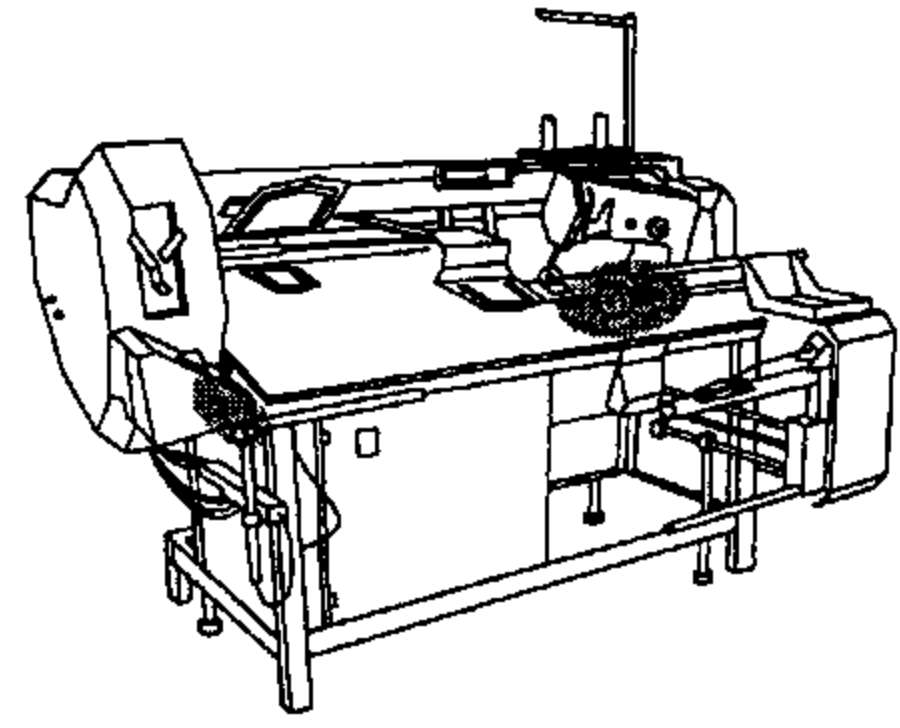

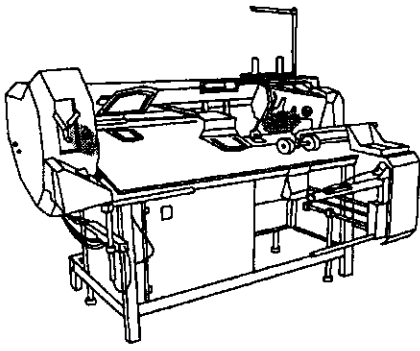

X-YAntrieb
 X-Y drive
 Système de commande X-Y
 Grupo de accionamiento "X-Y" PFAFF 3588-04/020

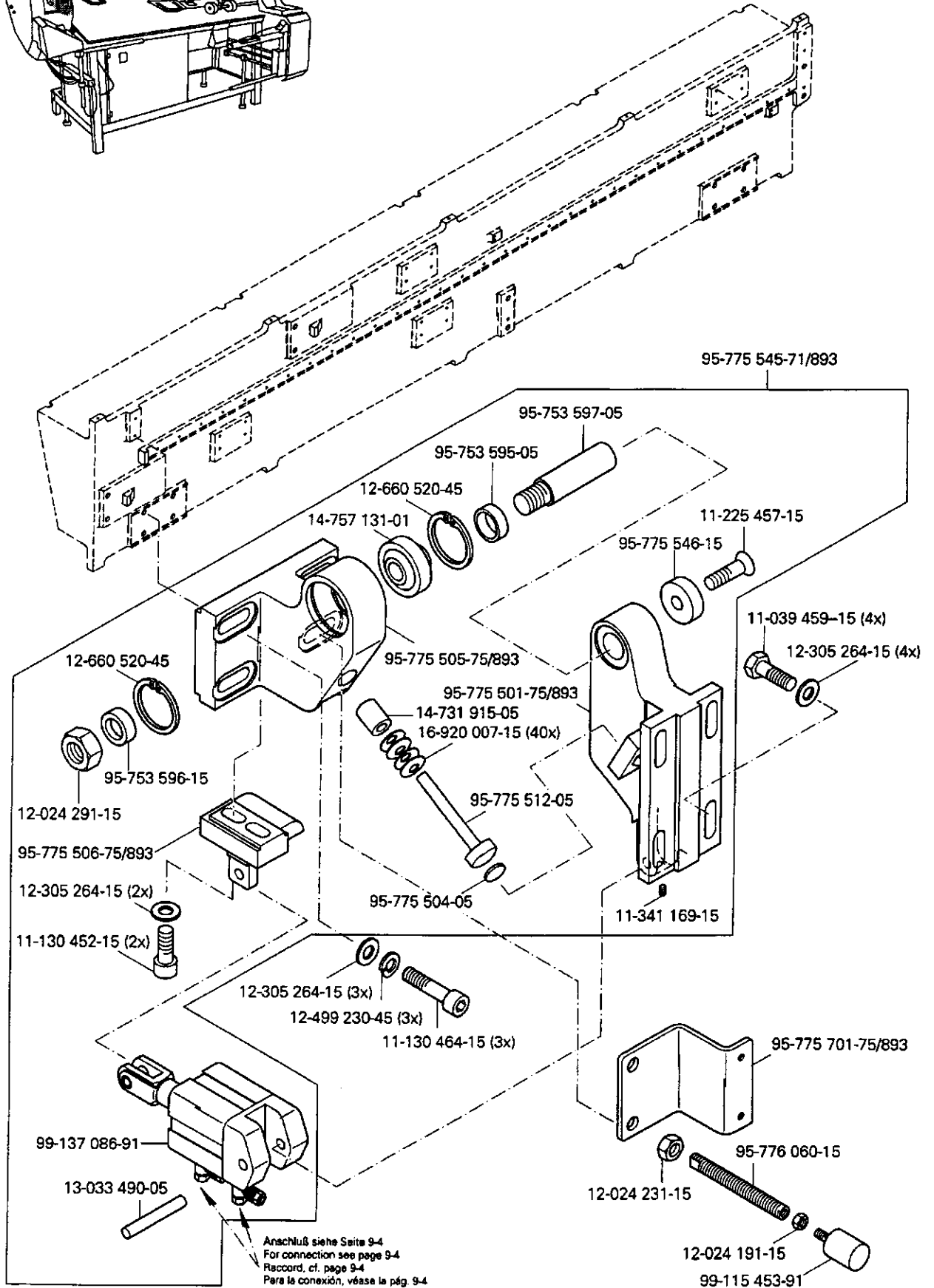

6

X-Y-Antrieb
X-Y drive
Système de commande X-Y
Grupo de accionamiento "X-Y" PFAFF 3588-04/020

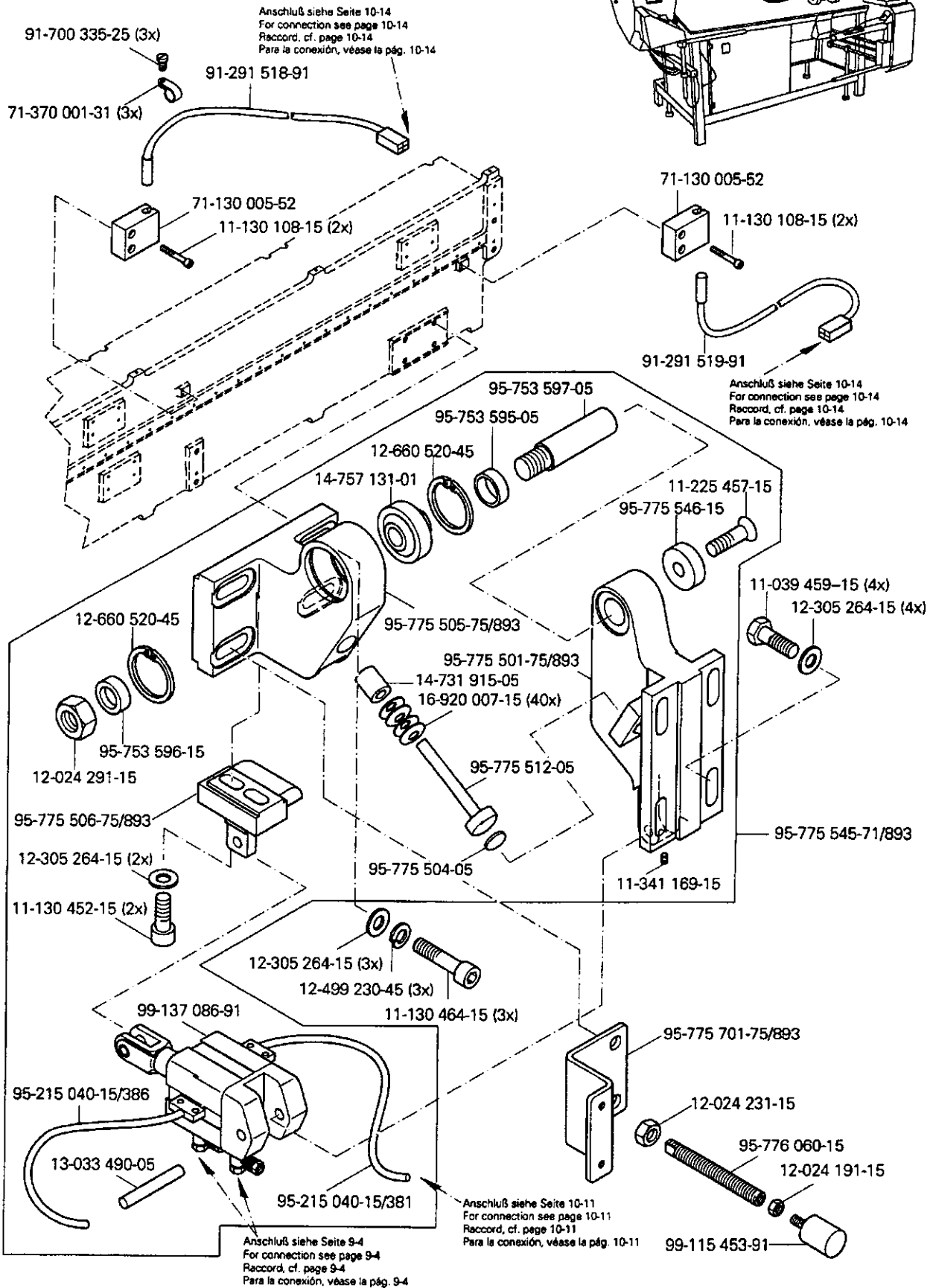
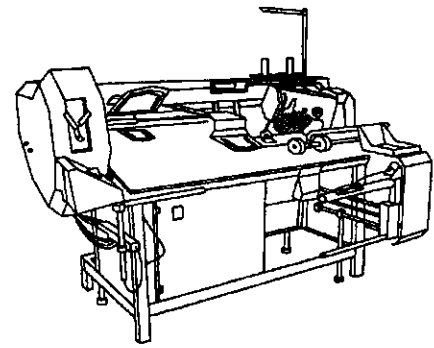

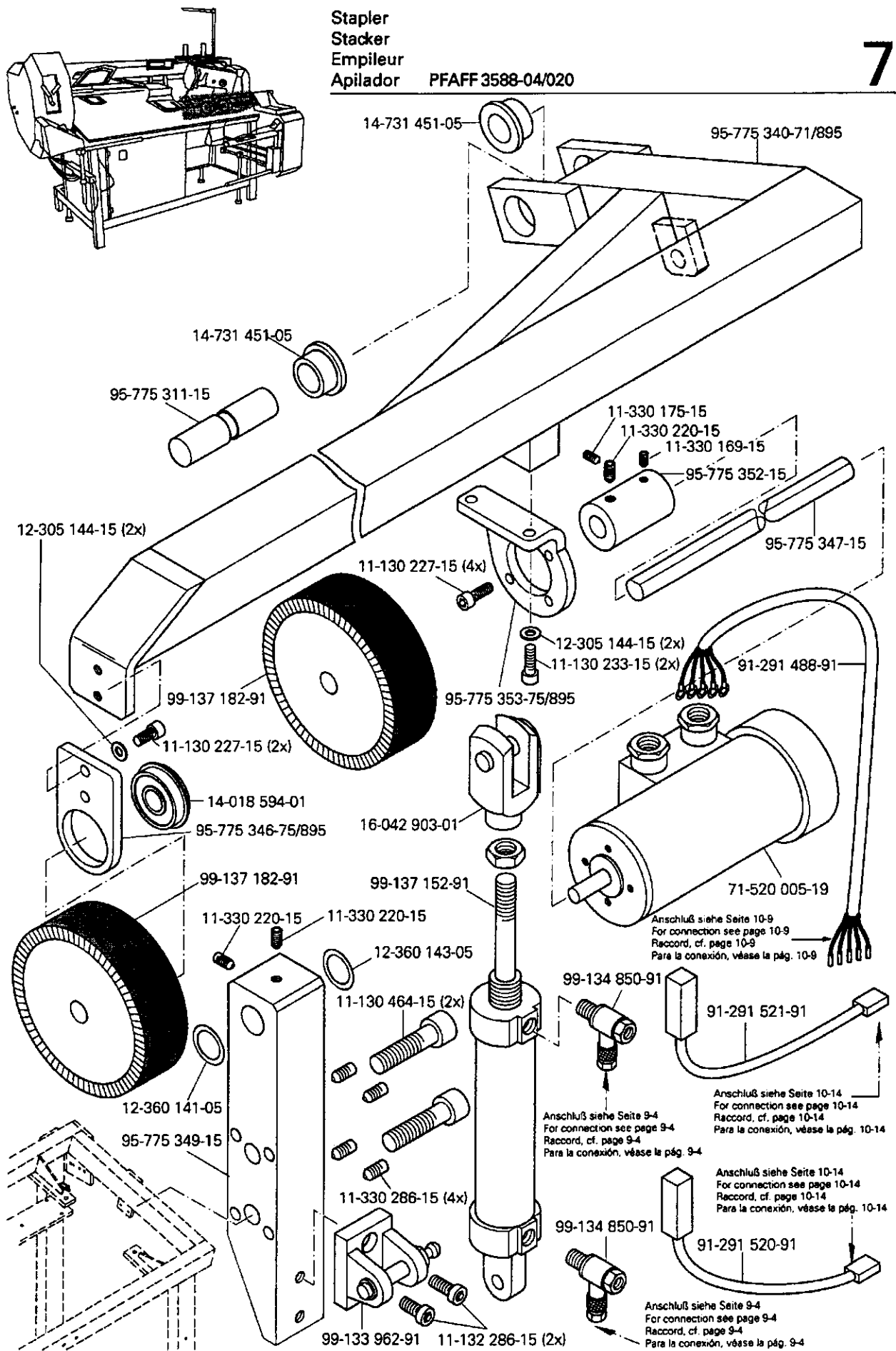

Anschluß siehe Seite 10-9
For connection see page 10-9
Raccord, cf. page 10-9
Para la conexión, véase la pág. 10-9

Anschluß siehe Seite 9-4
For connection see page 9-4
Raccord, cf. page 9-4
Para la conexión, véase la pág. 9-4

Anschluß siehe Seite 10-14
For connection see page 10-14
Raccord, cf. page 10-14
Para la conexión, véase la pág. 10-14

Anschluß siehe Seite 10-14
For connection see page 10-14
Raccord, cf. page 10-14
Para la conexión, véase la pág. 10-14

Anschluß siehe Seite 9-4
For connection see page 9-4
Raccord, cf. page 9-4
Para la conexión, véase la pág. 9-4

7

Stapler
Stacker
Empileur
Apilador PFAFF 3588-04/020

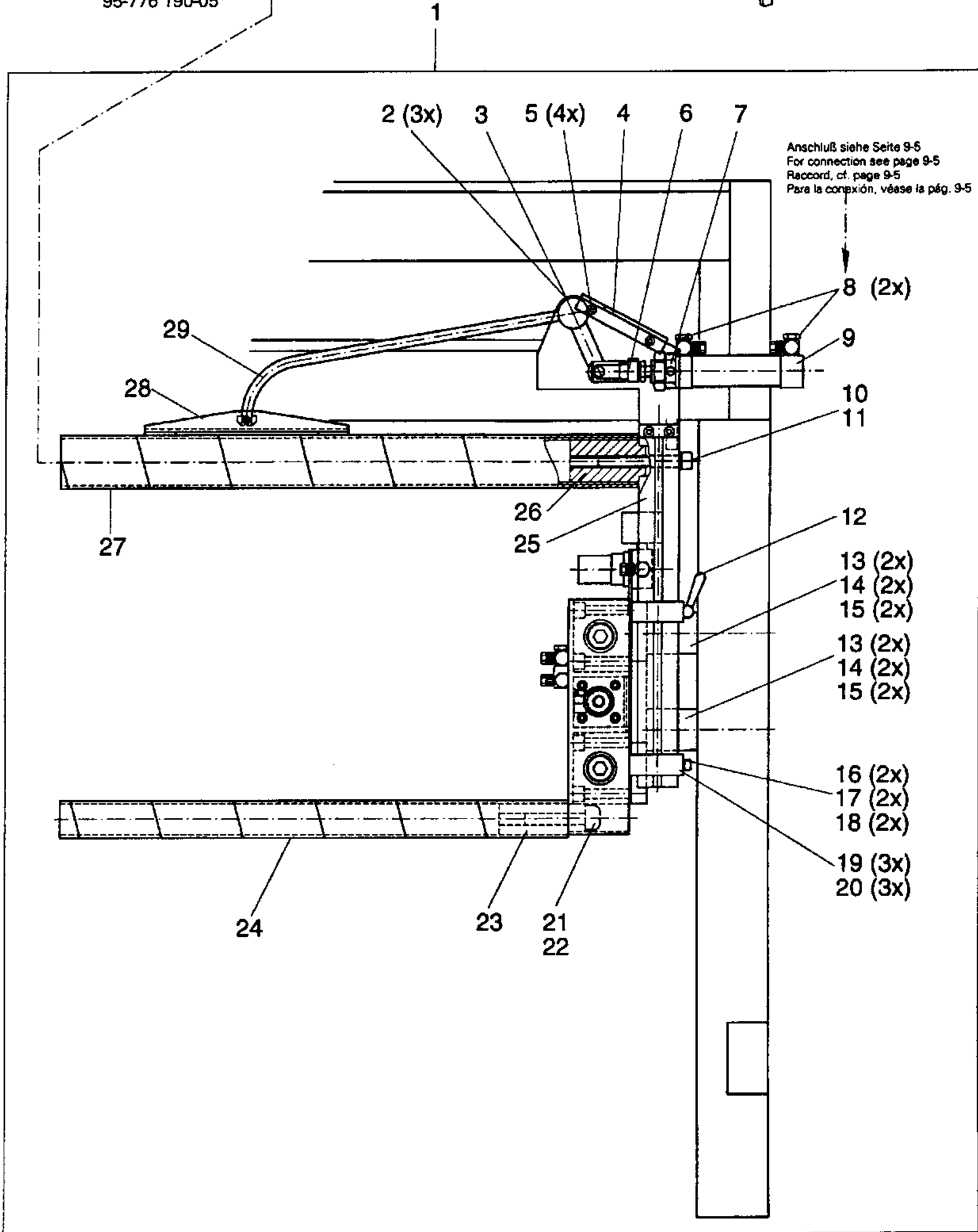
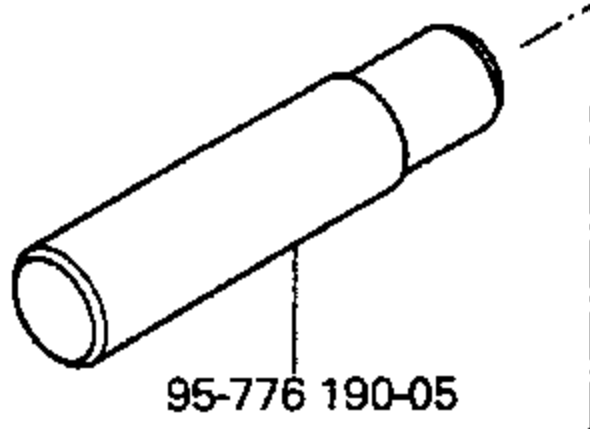
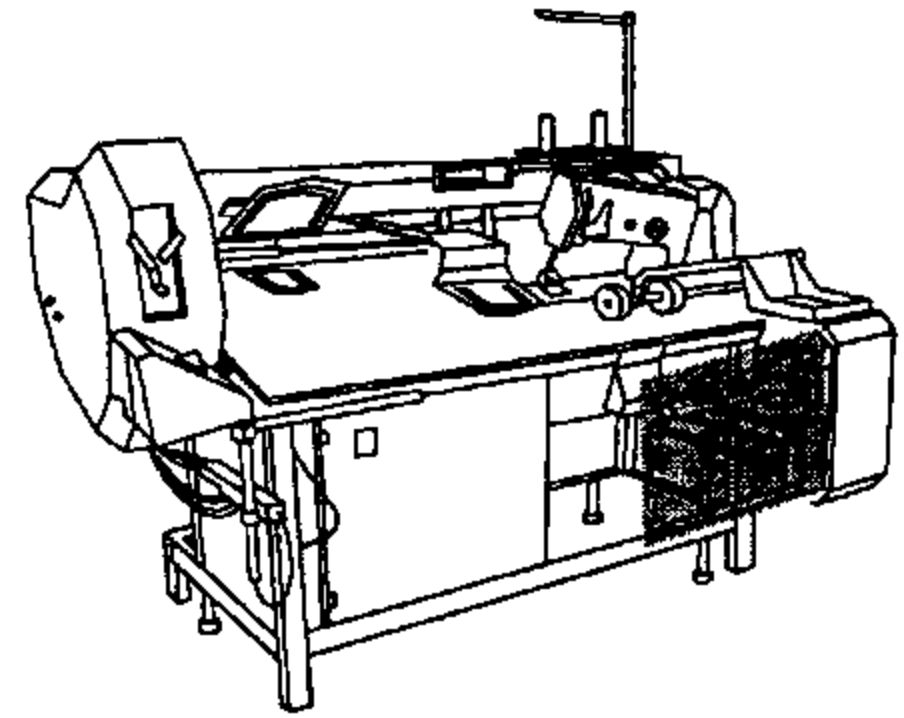

Pos.-Nr. Item No. N° pos. N° de pos.	Bestellnummer Part number N° de commande N° de pedido	Teile-Benennung Description Désignation Denominación	Pos.-Nr. Item No. N° pos. N° de pos.	Bestellnummer Part number N° de commande N° de pedido	Teile-Benennung Description Désignation Denominación
1	95-775 622-71/895	Stapler Stacker Empileur Apilador	17	95-215 040-13/591	Führung 20 x 27 x 60 Guide Guide Guía
2	11-330 280-15	Gewindestift M6 x 8 Threaded stud Vis sans tête Tornillo prisionero	18	95-215 040-14/136	Distanzstück Spacer Pièce d'écartement Pieza distanciadora
3	95-215 040-14/141	Klemmstück Clamping piece Pièce de serrage Pieza presora	19	11-130 332-15	Zylinderschraube M6 x 65 Pan-head screw Vis à tête cylindrique Tornillo cilíndrico
4	95-215 040-13/878	Deckel Cover Couvercle Tapa	20	12-499 190-45	Federring 6 Spring washer Rondelle élastique Arandela elástica
5	11-225 220-15	Senkschraube M5 x 8 Countersunk screw Vis à tête noyée Tornillo avellanado	21	11-130 719-15	Zylinderschraube M16 x 40 Pan-head screw Vis à tête cylindrique Tornillo cilíndrico
6	95-215 000-02/255	Gabelkopf Fork head Fourche Cabeza horquillada	22	12-499 290-45	Federring 16 Spring washer Rondelle élastique Arandela elástica
7	95-215 040-14/145	Schwenkstück Swivel piece Pièce pivotante Pieza giratoria	23	95-215 040-14/132	Rohrverbindung 27 x 40 Tube connection Raccord de tuyaux Unión de tubos
8	95-215 080-18/008	Drosselrückschlagventil 1/8" Check-return valve Clapet anti-retour avec étranglement Válvula estranguladora de retroceso	24	95-215 040-13/923	Rohr Tube Tube Tubo
9	95-215 000-03/992	Zylinder, doppeltwirkend Cylinder, double-acting Vérin à double effet Cilindro de doble efecto	25	95-215 040-14/134	Klemmstück 40 x 40 x 343 Clamping piece Pièce de serrage Pieza presora
10	11-130 563-15	Zylinderschraube M12 x 60 Pan-head screw Vis à tête cylindrique Tornillo cilíndrico	26	95-215 040-14/133	Rohrverbindung 42 x 58 Tube connection Raccord de tuyaux Unión de tubos
11	95-215 070-05/901	Federring 12 Spring washer Rondelle élastique Arandela elástica	27	95-215 040-13/921	Rohr Tube Tube Tubo
12	95-215 040-14/148	Klemmhebel Clamp lever Lever de serrage Palanca de fricción	28	95-215 040-14/143	Niederhalter Retainer Serre-ouvrage Sujetatelas
13	95-215 040-14/146	Distanzstück Spacer Pièce d'écartement Pieza distanciadora	29	95-215 040-12/561	Schwenkarm Swivel arm Bras oscillant Brazo giratorio
14	11-130 482-15	Zylinderschraube M10 x 70 Pan-head screw Vis à tête cylindrique Tornillo cilíndrico	30	95-215 040-13/877	Blech Plate Tôle Chapa
15	12-499 230-45	Federring 10 Spring washer Rondelle élastique Arandela elástica	31	11-130 377-15	Zylinderschraube M8 x 30 Pan-head screw Vis à tête cylindrique Tornillo cilíndrico
16	95-215 040-13/535	Führung 20 x 24 x 60 Guide Guide Guía	32	95-215 040-03/316	Anschlußplatte Connection plate Plaque de raccordement Placa de conexión

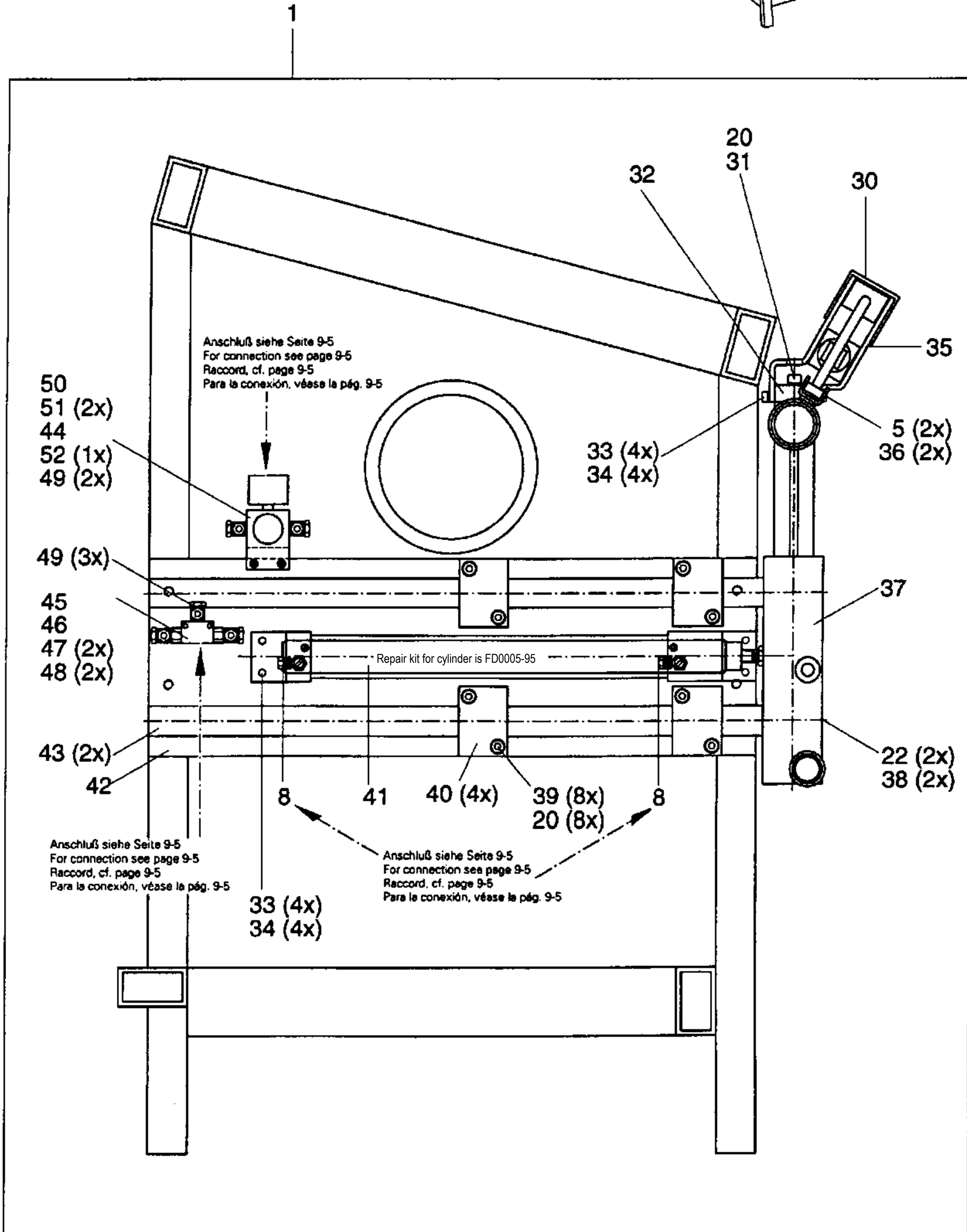
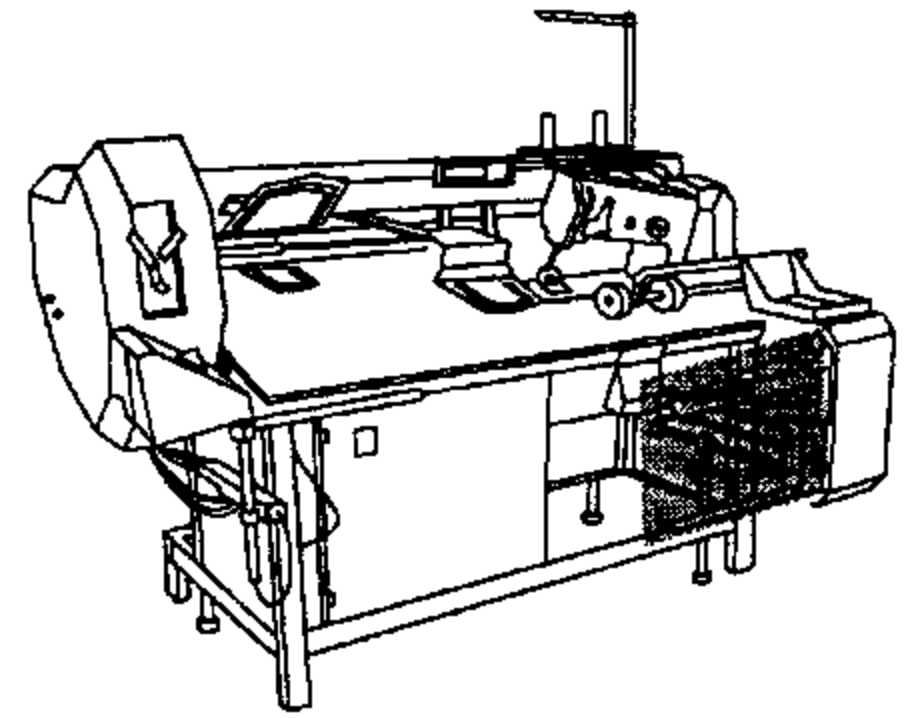

Pos.-Nr. Item No. N° pos. N° de pos.	Bestellnummer Part number N° de commande N° de pedido	Teile-Benennung Description Désignation Denominación	Pos.-Nr. Item No. N° pos. N° de pos.	Bestellnummer Part number N° de commande N° de pedido	Teile-Benennung Description Désignation Denominación
33	11-130 293-15	Zylinderschraube M6 x 16 Pan-head screw Vis à tête cylindrique Tornillo cilíndrico	49	95-215 080-18/102	Schwenkverschraubung Swivel union Raccord pivotant Racora orientable
34	12-499 190-45	Federring 6 Spring washer Rondelle élastique Arandela elástica	50	95-215 040-15/131	Befestigungsblech Mounting plate Plaque de montage Placa de fijación
35	95-215 040-13/880	Blech Plate Tôle Chapa	51	11-130 227-15	Zylinderschraube M5 x 12 Pan-head screw Vis à tête cylindrique Tornillo cilíndrico
36	12-505 171-15	Federscheibe B5 Spring washer Rondelle élastique Arandela elástica	52	95-215 080-17/605	Mutter M30 x 1,5 Nut Ecrou Tuerca
37	95-215 040-14/135	Klotz 60 x 230 Block Bloc Bloque			
38	11-130 719-15	Zylinderschraube M16 x 40 Pan-head screw Vis à tête cylindrique Tornillo cilíndrico			
39	11-130 395-15	Zylinderschraube M8 x 60 Pan-head screw Vis à tête cylindrique Tornillo cilíndrico			
40	95-215 040-13/534	Führung Guide Guide Guía			
41	95-215 000-03/413	Zylinder, doppeltwirkend Cylinder, double-acting Vérin à double effet Cilindro de doble efecto			
42	95-215 040-14/138	Grundplatte Baseplate Plaque fondamentale Placa base			
43	95-215 040-12/569	Führungstange Guide bar Barre de guidage Barra-guía			
44	95-215 080-17/604	Druckregler Pressure regulator Régulateur de pression Regulador de presión			
45	95-215 080-14/925	Doppelrückschlagventil G1/8 Double-check valve Double valve d'arrêt Doble válvula de retención			
46	95-215 040-14/161	Distanzklotz Spacing block Bloc d'écartement Taco distanciador			
47	11-130 179-15	Zylinderschraube M4 x 12 Pan-head screw Vis à tête cylindrique Tornillo cilíndrico			
48	11-130 191-15	Zylinderschraube M4 x 20 Pan-head screw Vis à tête cylindrique Tornillo cilíndrico			

7

Stapler
Stacker
Empileur
Apilador PFAFF 3588-04/020

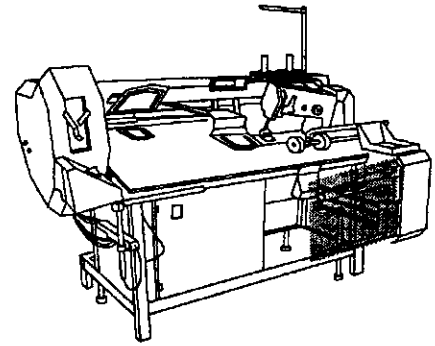

Anschluß siehe Seite 10-11
For connection see page 10-11
Raccord, cf. page 10-11
Para la conexión, véase la pág. 10-11

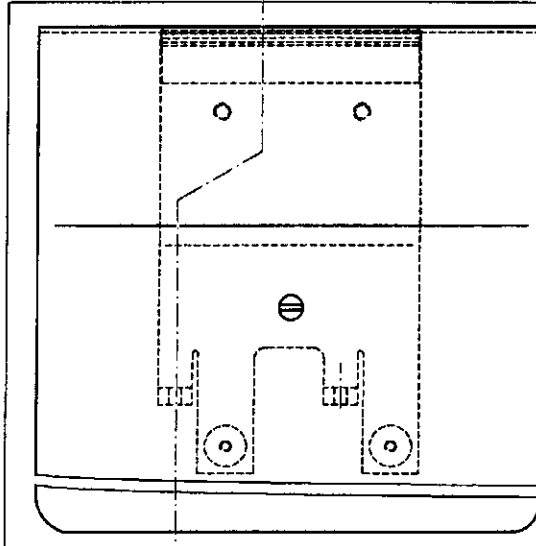
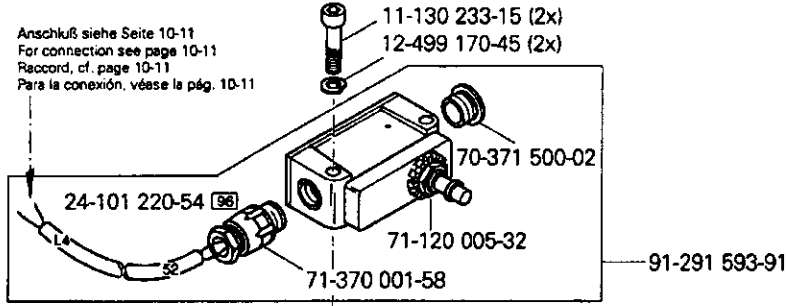

12-024 171-15 (2x)

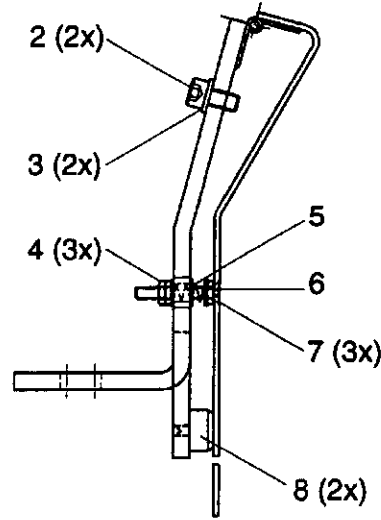

Pos.-Nr. Item No. N° pos. N° de pos.	Bestellnummer Part number N° de commande N° de pedido	Teile-Benennung Description Désignation Denominación	Pos.-Nr. Item No. N° pos. N° de pos.	Bestellnummer Part number N° de commande N° de pedido	Teile-Benennung Description Désignation Denominación
1	95-775 644-71/895	Träger vollst. Bracket assy. Support complet Soporte completo	5	91-022 116-05	Druckfeder Pressure spring Ressort de pression Muelle de presión
2	11-130 287-15	Zylinderschraube M6 x 12 Pan-head screw Vis à tête cylindrique Tornillo cilíndrico	6	11-225 196-15	Senkschraube M4 x 25 Countersunk screw Vis à tête noyée Tornillo avellanado
3	12-305 174-15	Scheibe 6,4 Washer Rondelle Arandela	7	12-305 114-15	Scheibe 4,3 Washer Rondelle Arandela
4	12-024 151-15	Sechskantmutter M4 Hexagon nut Ecrou à six pans Tuerca hexagonal	8	91-024 554-05	Anschlag Stop Butée Tope

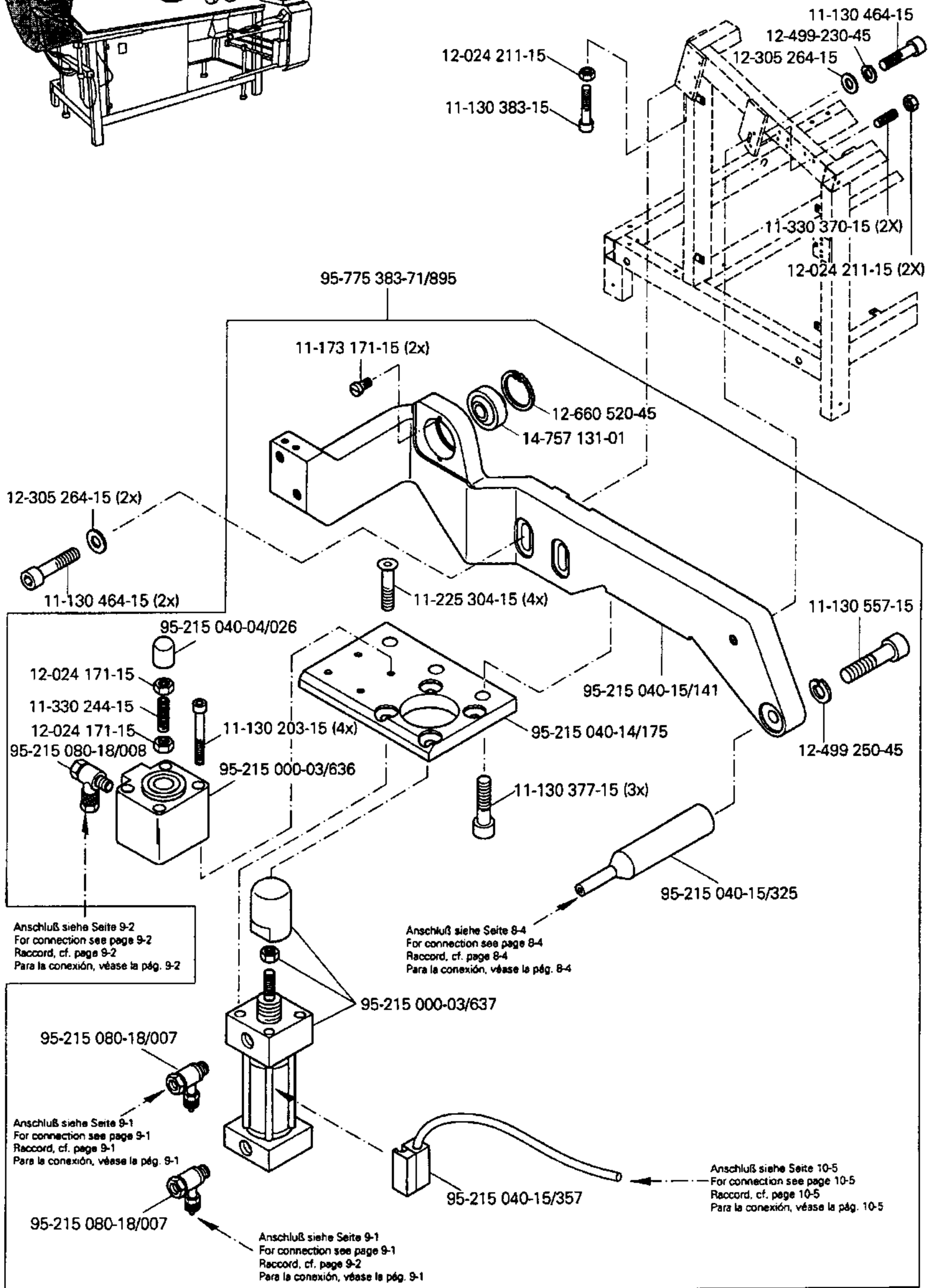
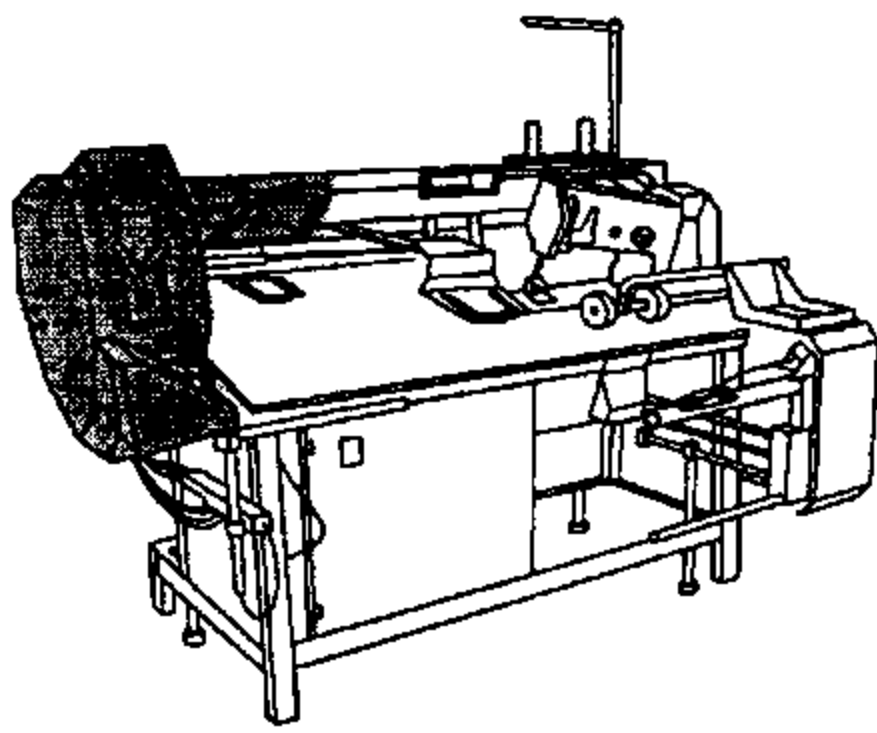

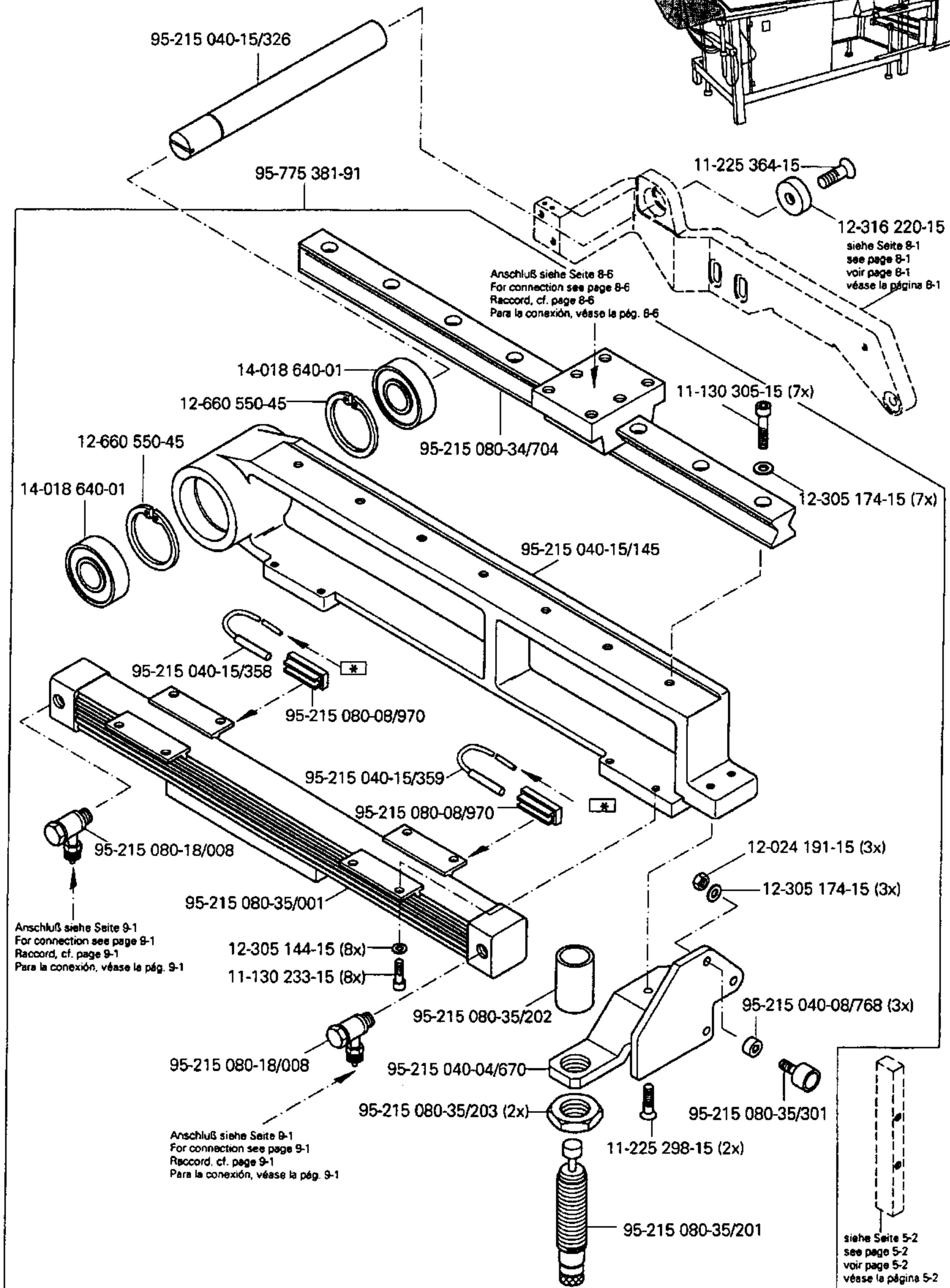
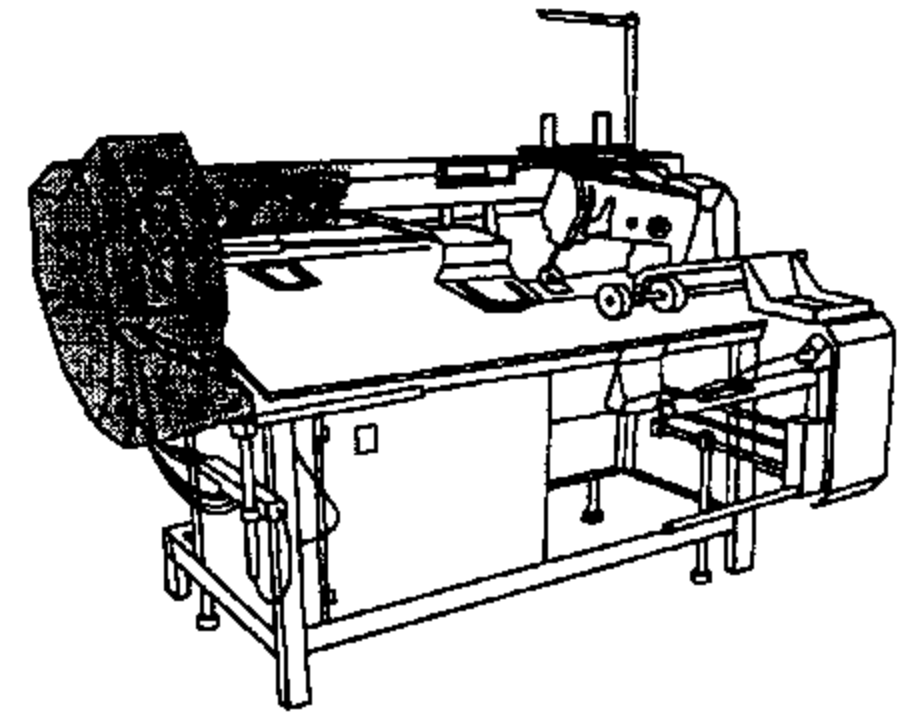

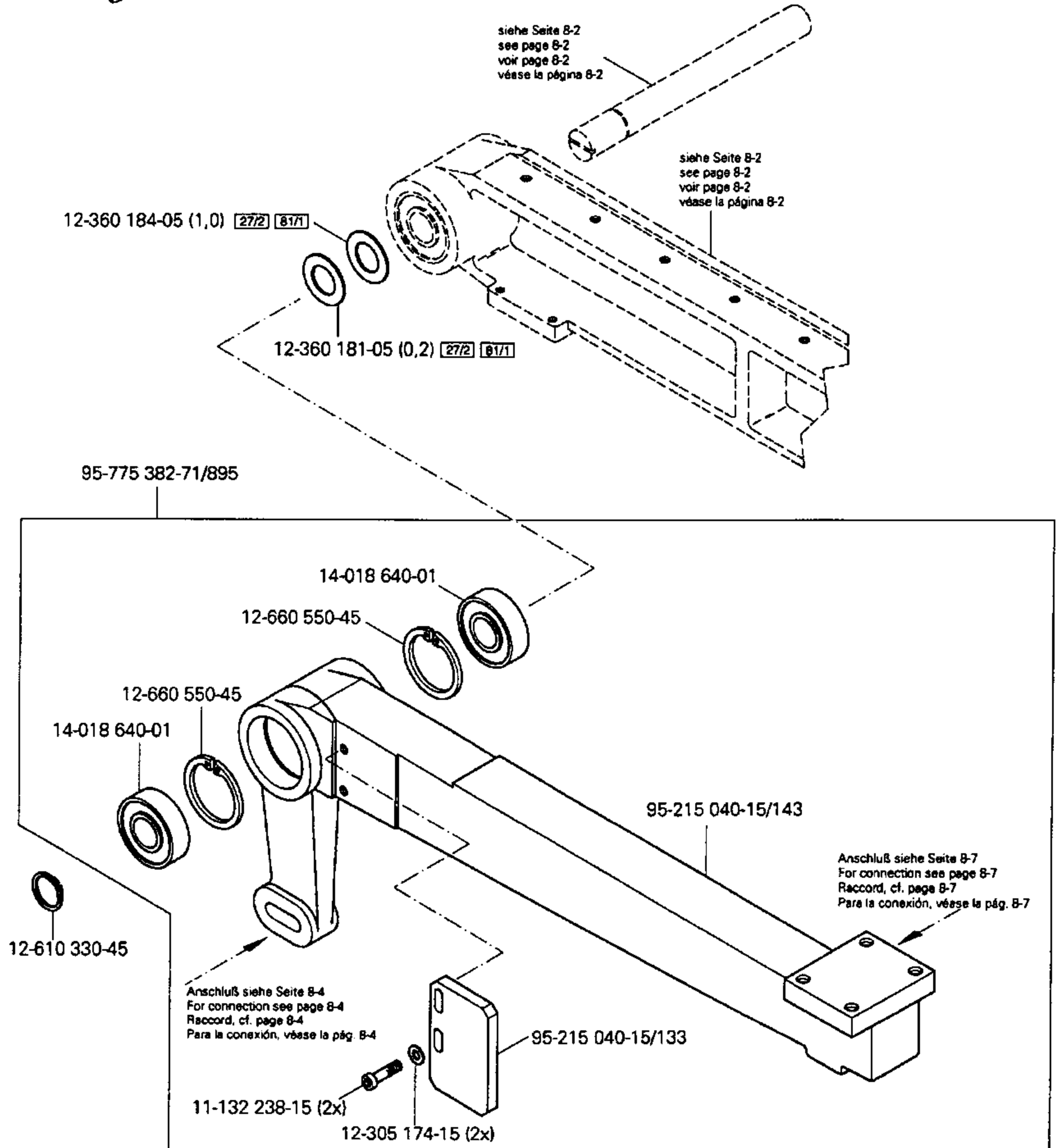
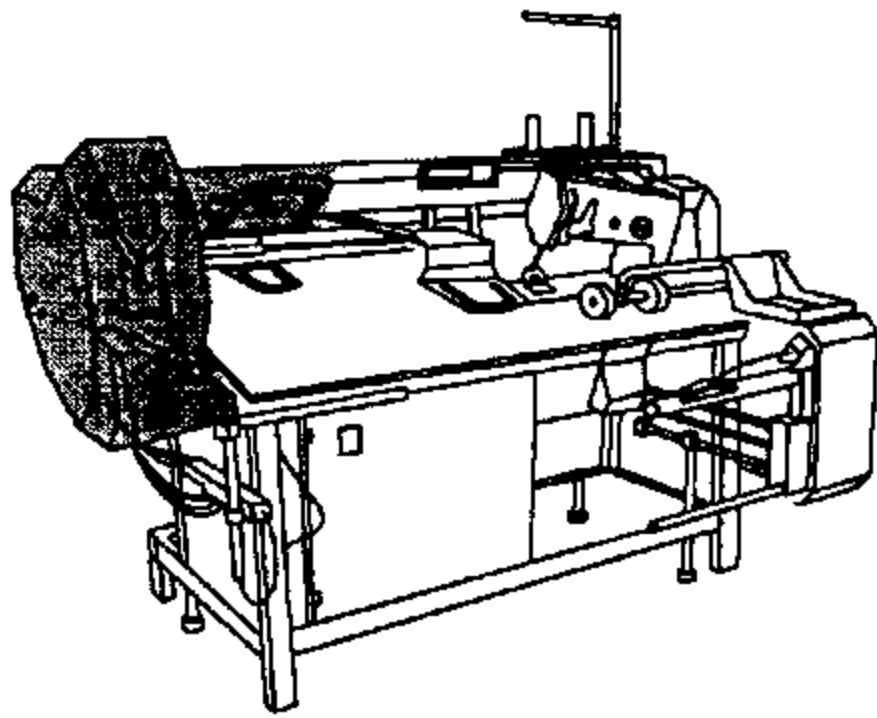

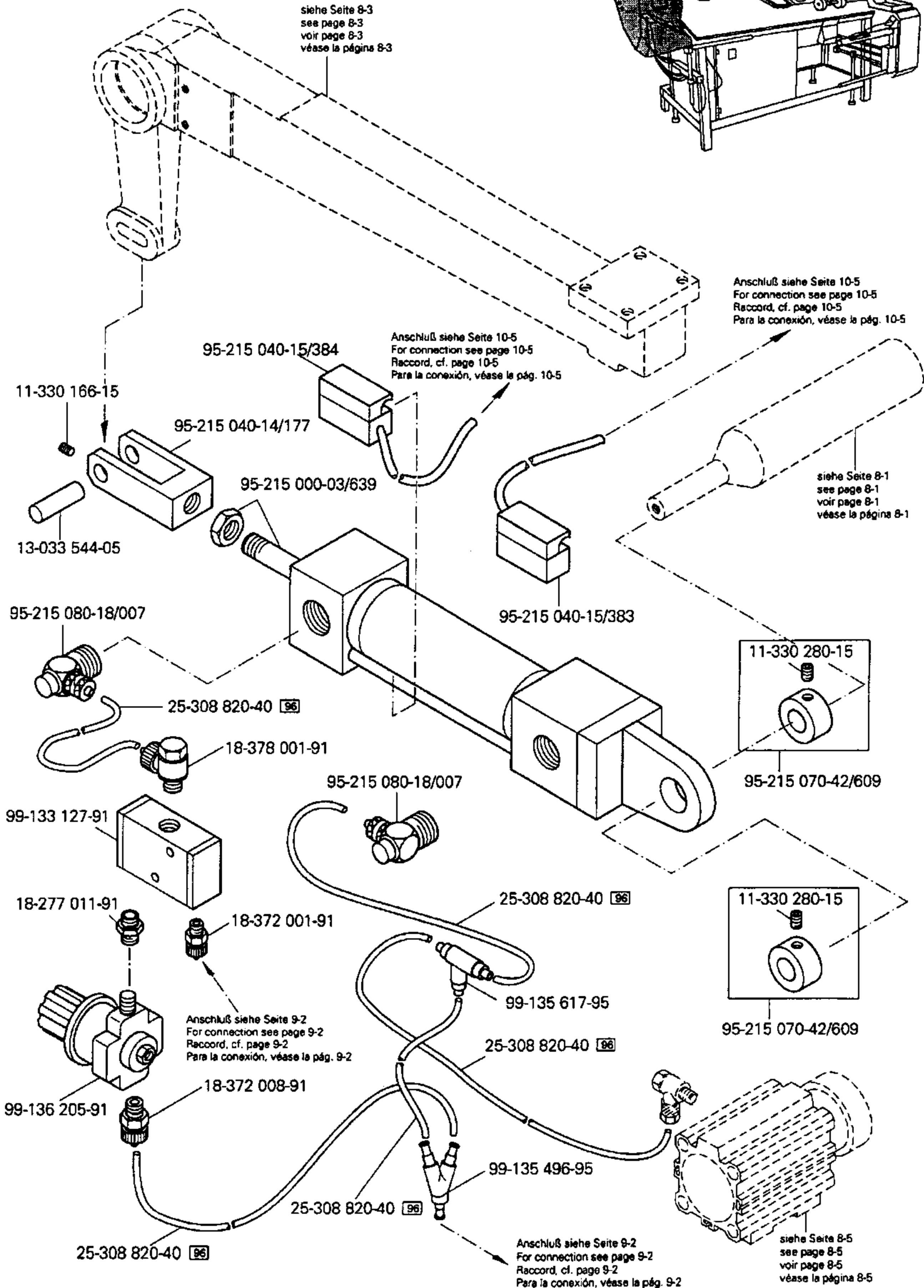
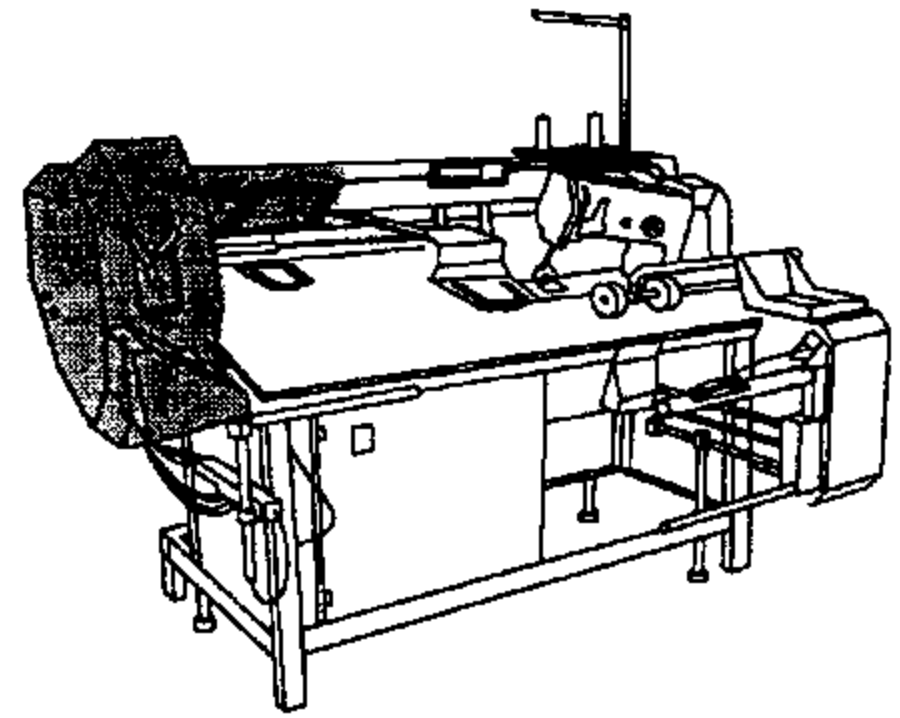

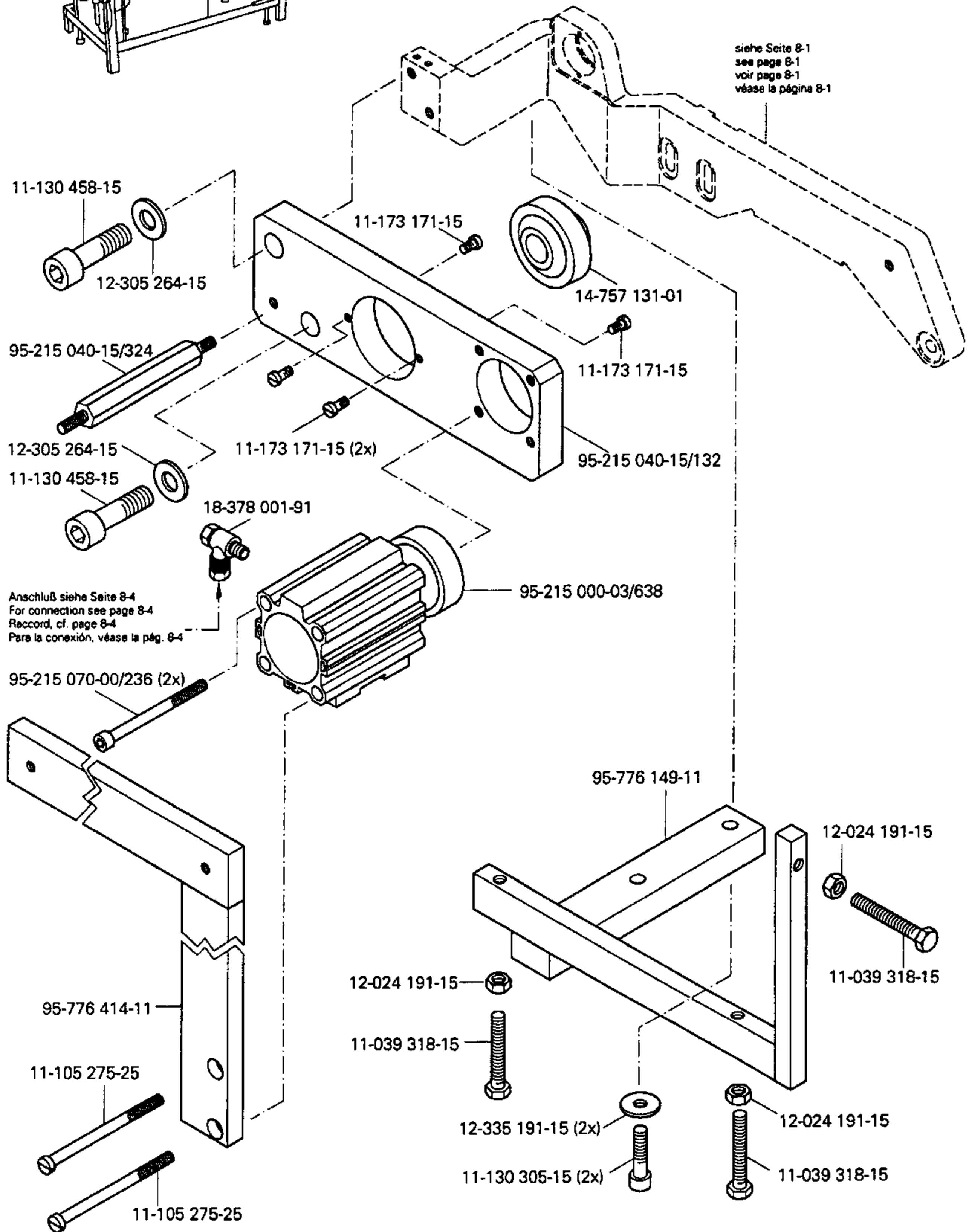
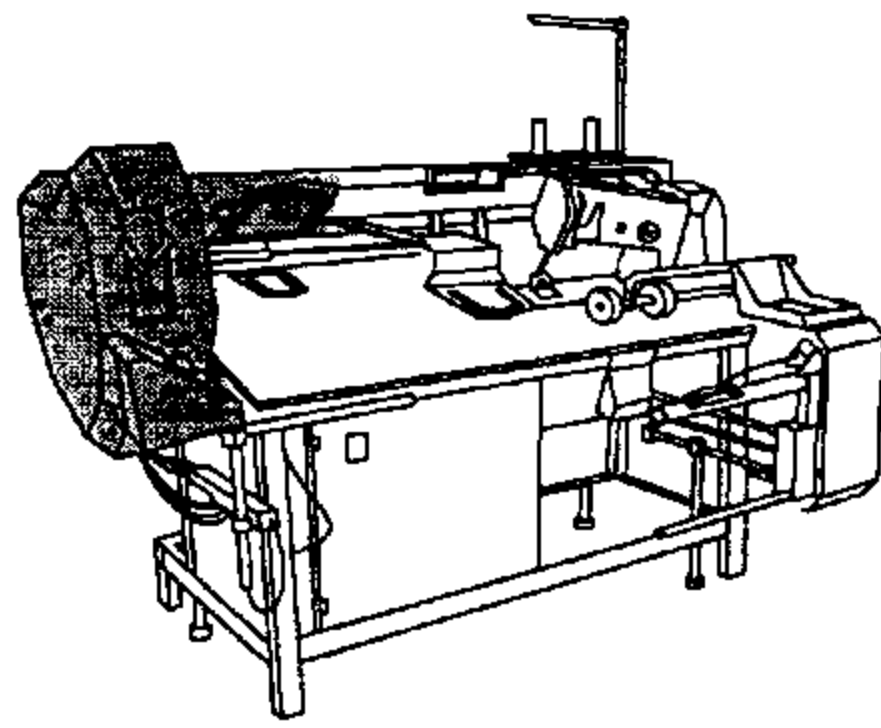

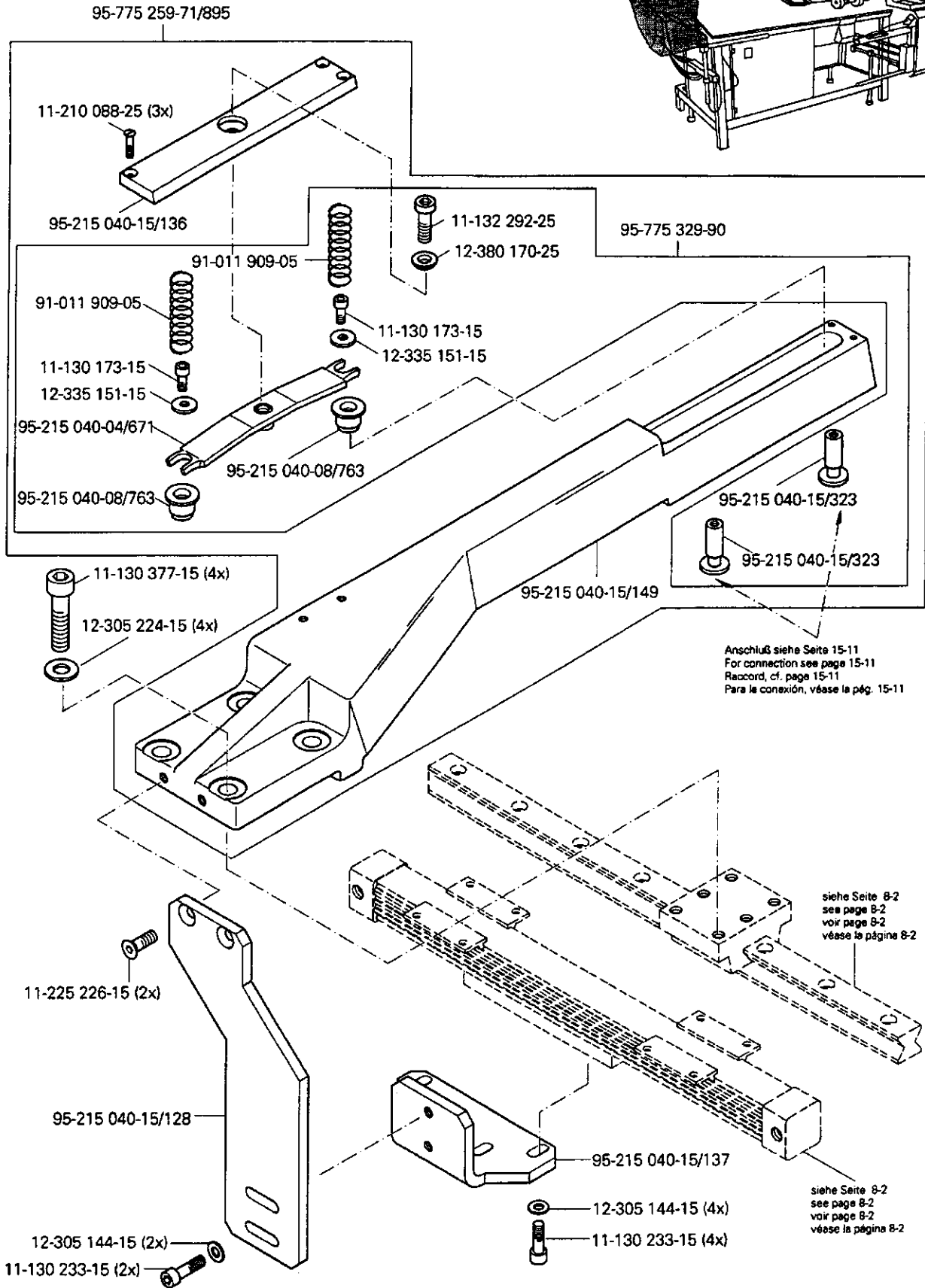
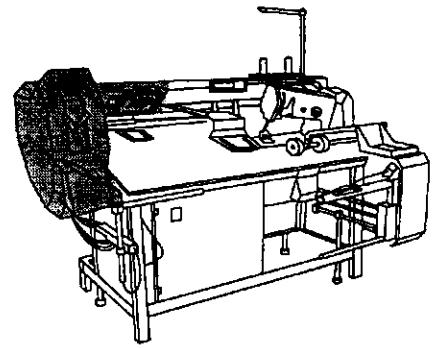

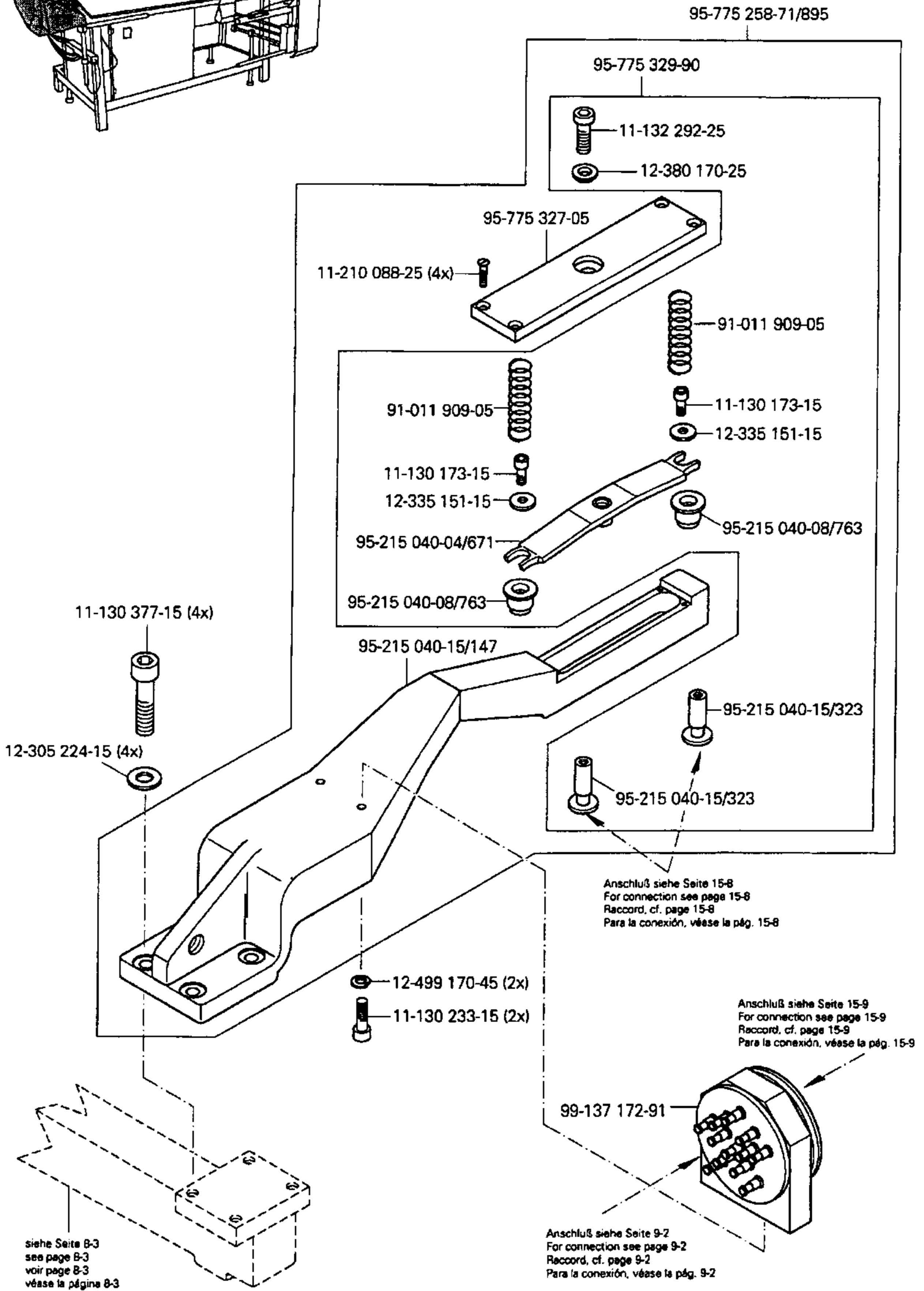
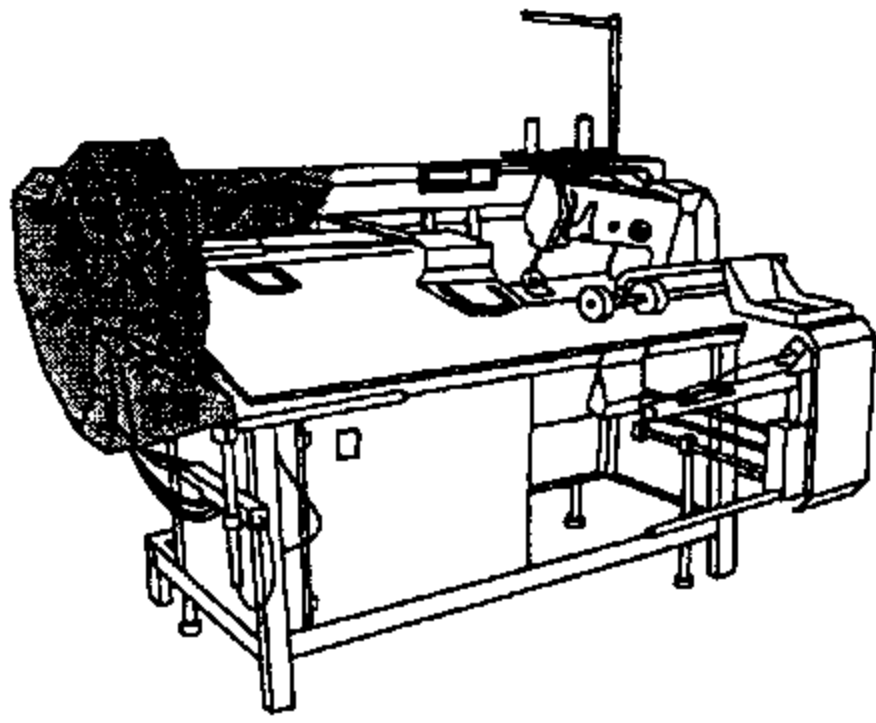

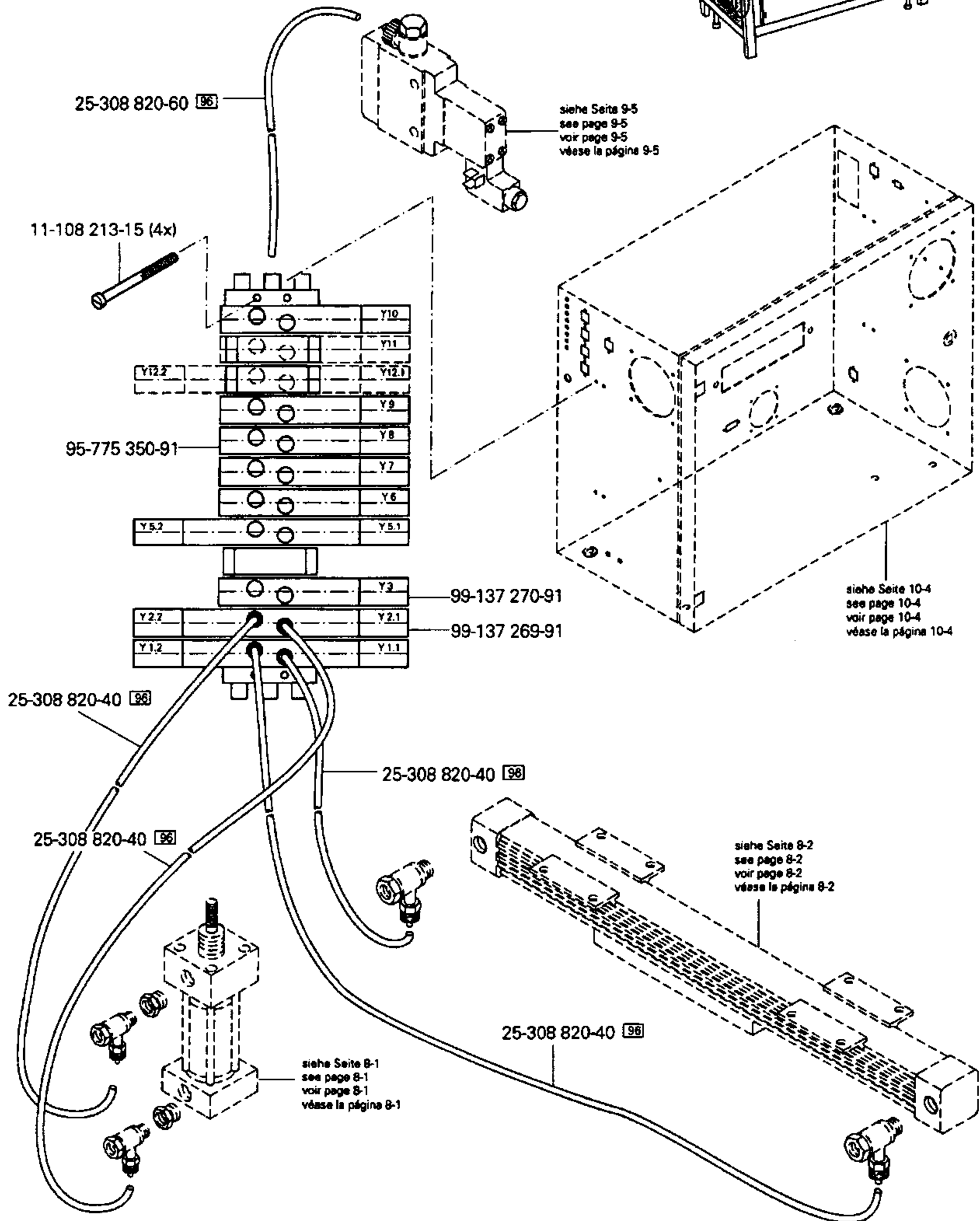
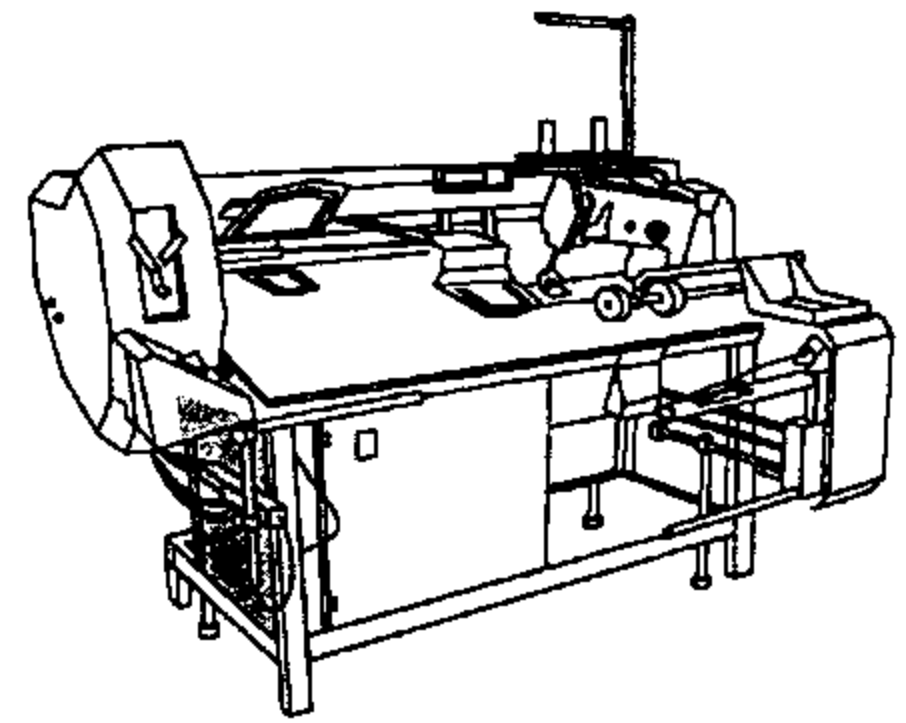

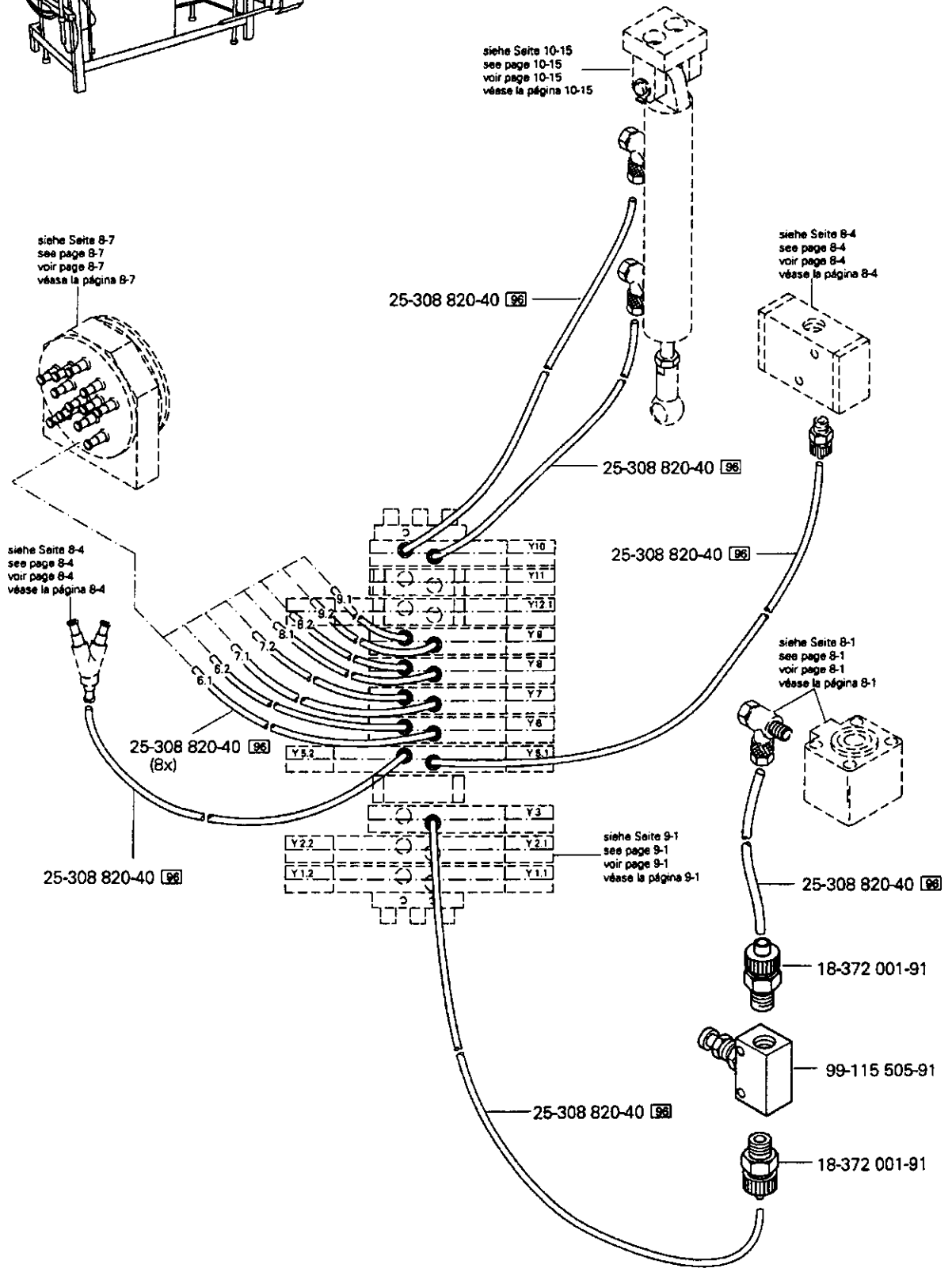
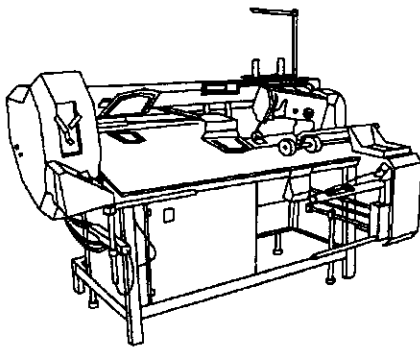

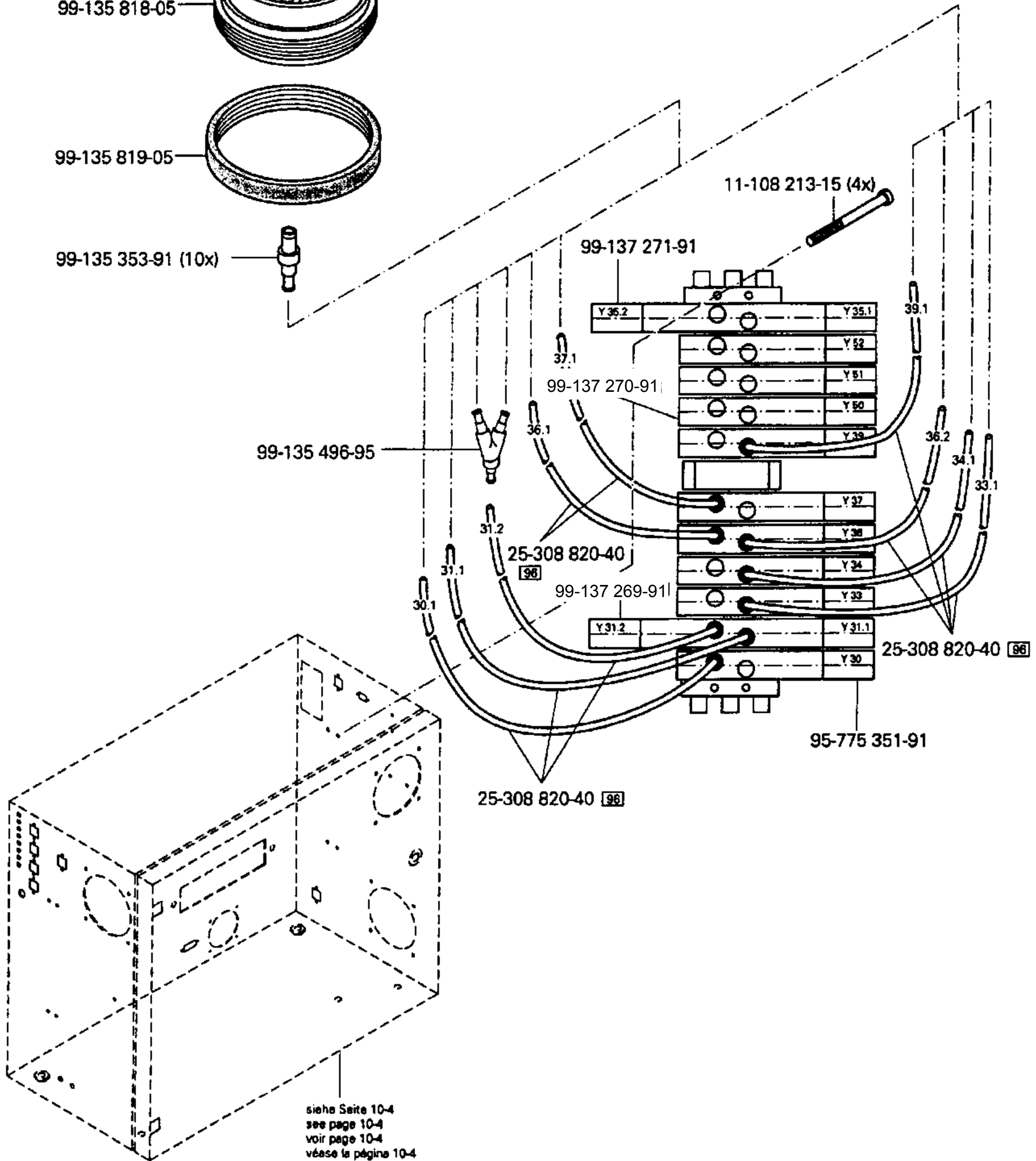
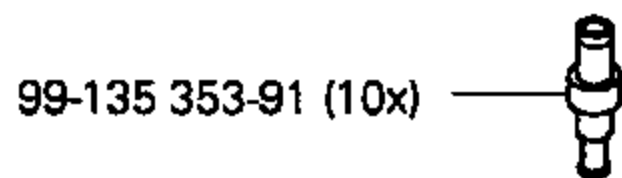
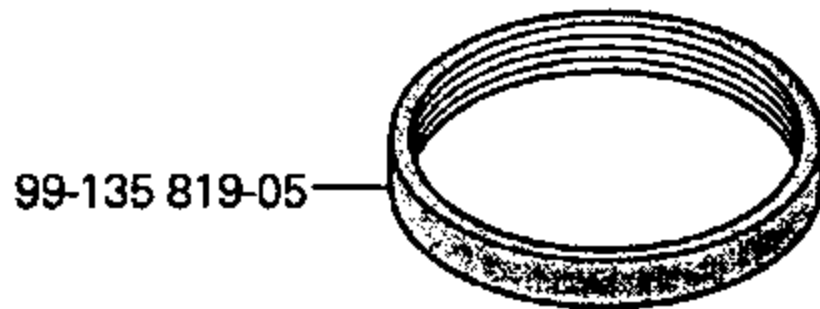
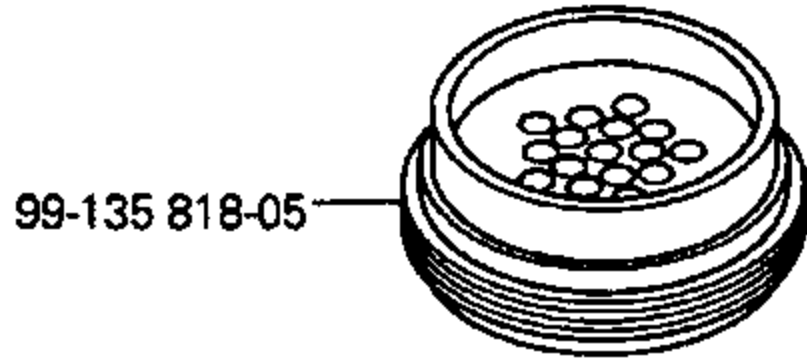
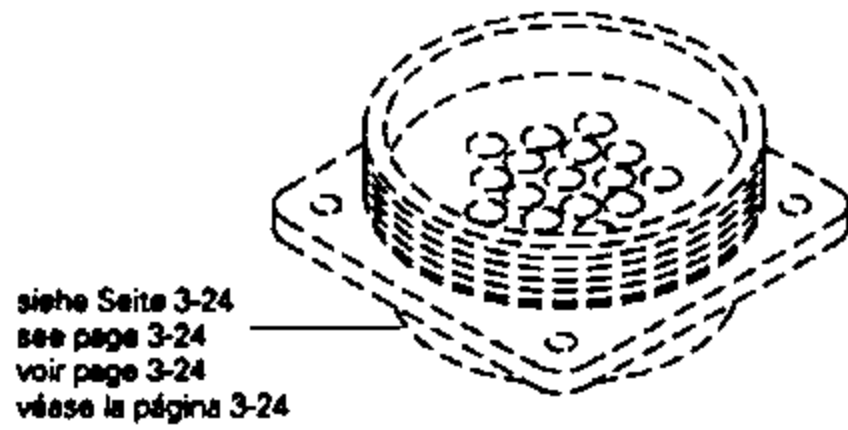
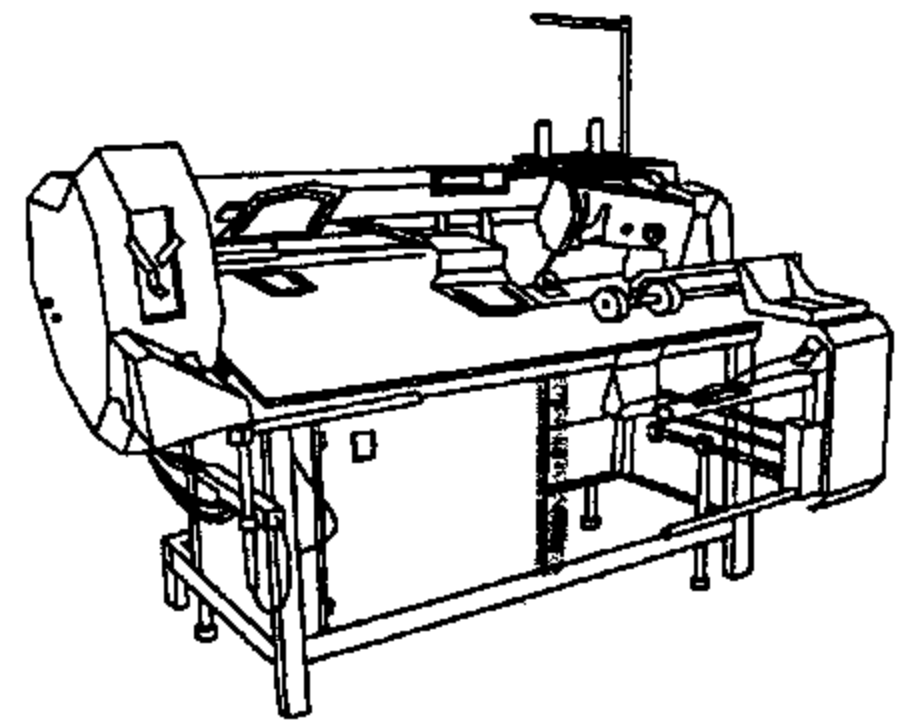

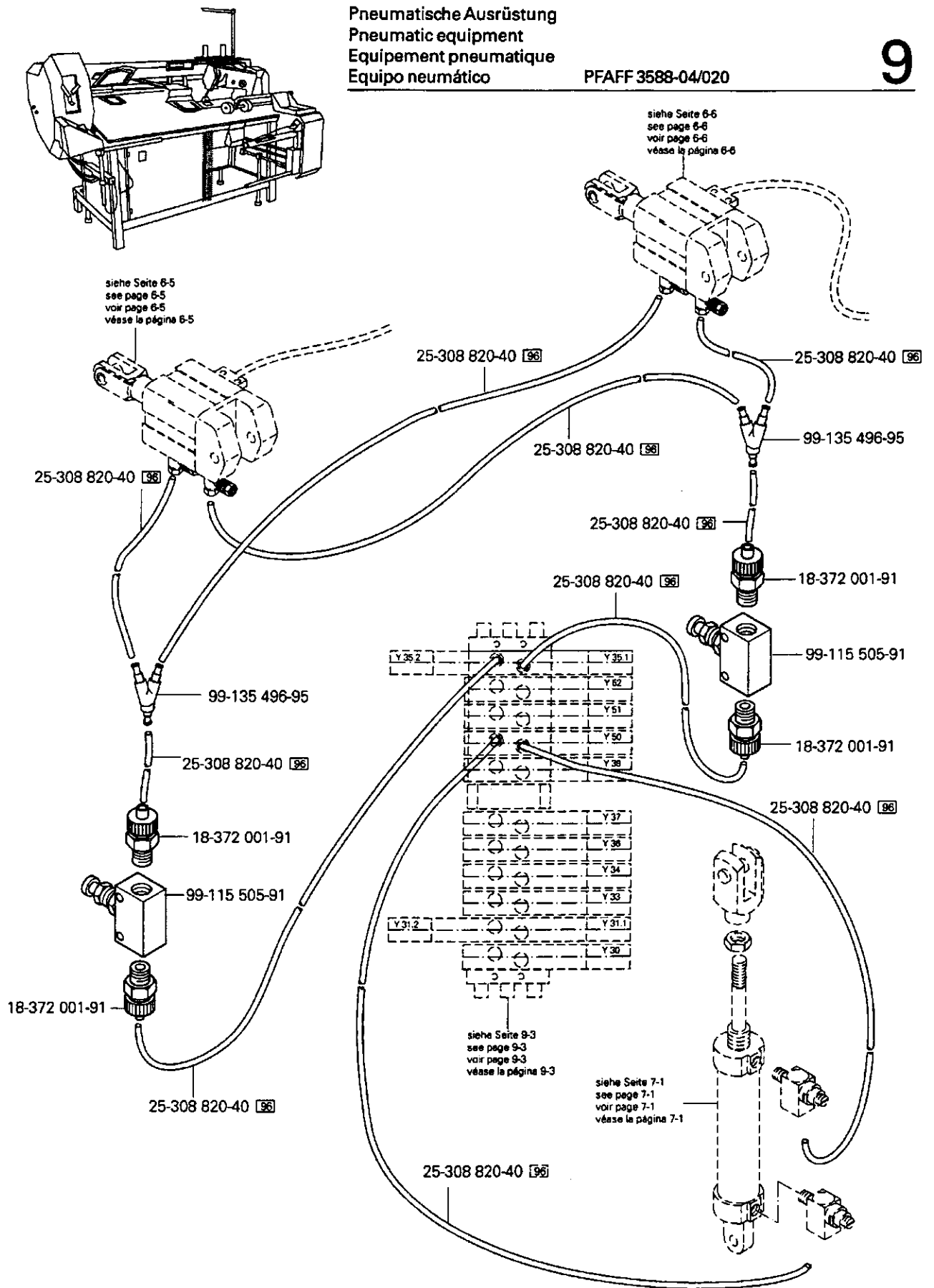

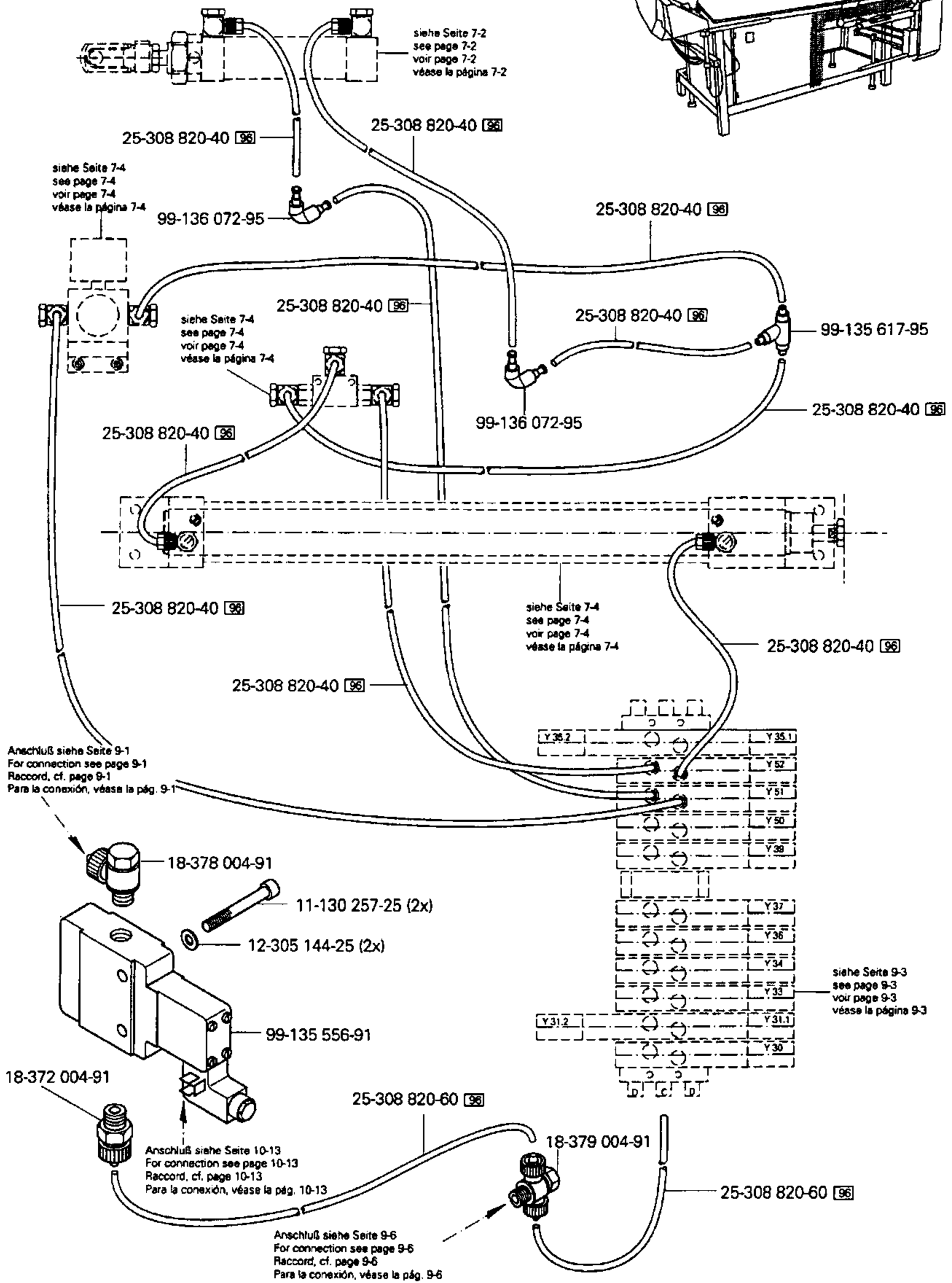
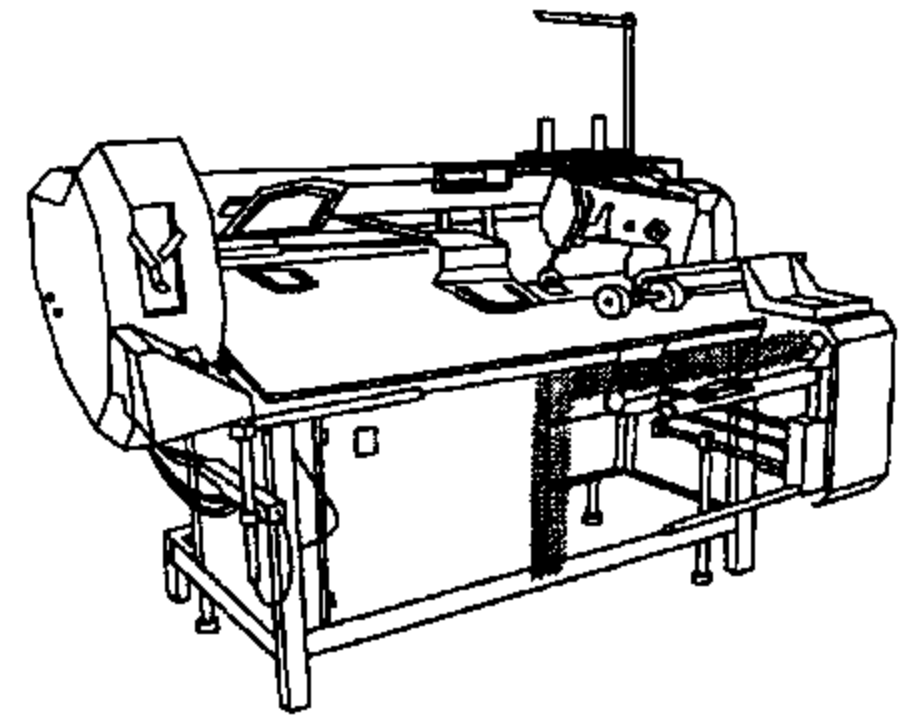

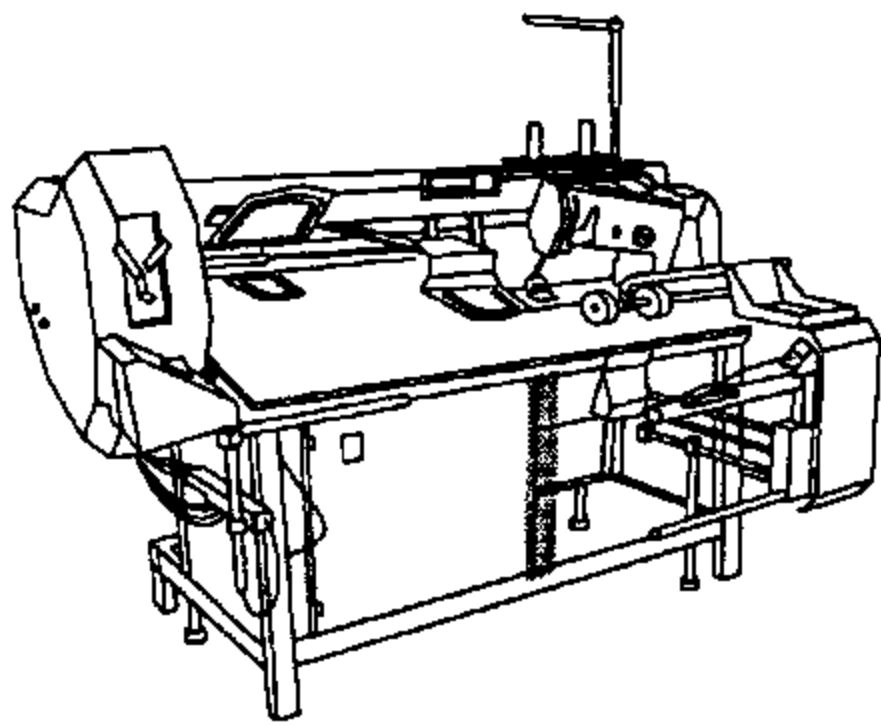

Anschluß siehe Seite 10-11
 For connection see page 10-11
 Raccord, cf. page 10-11
 Para la conexión, véase la pág. 10-11

91-291 512-91

Anschluß siehe Seite 9-5
 For connection see page 9-5
 Raccord, cf. page 9-5
 Para la conexión, véase la pág. 9-5

99-137-170-91

Anschluß siehe Seite 9-5
 For connection see page 9-5
 Raccord, cf. page 9-5
 Para la conexión, véase la pág. 9-5

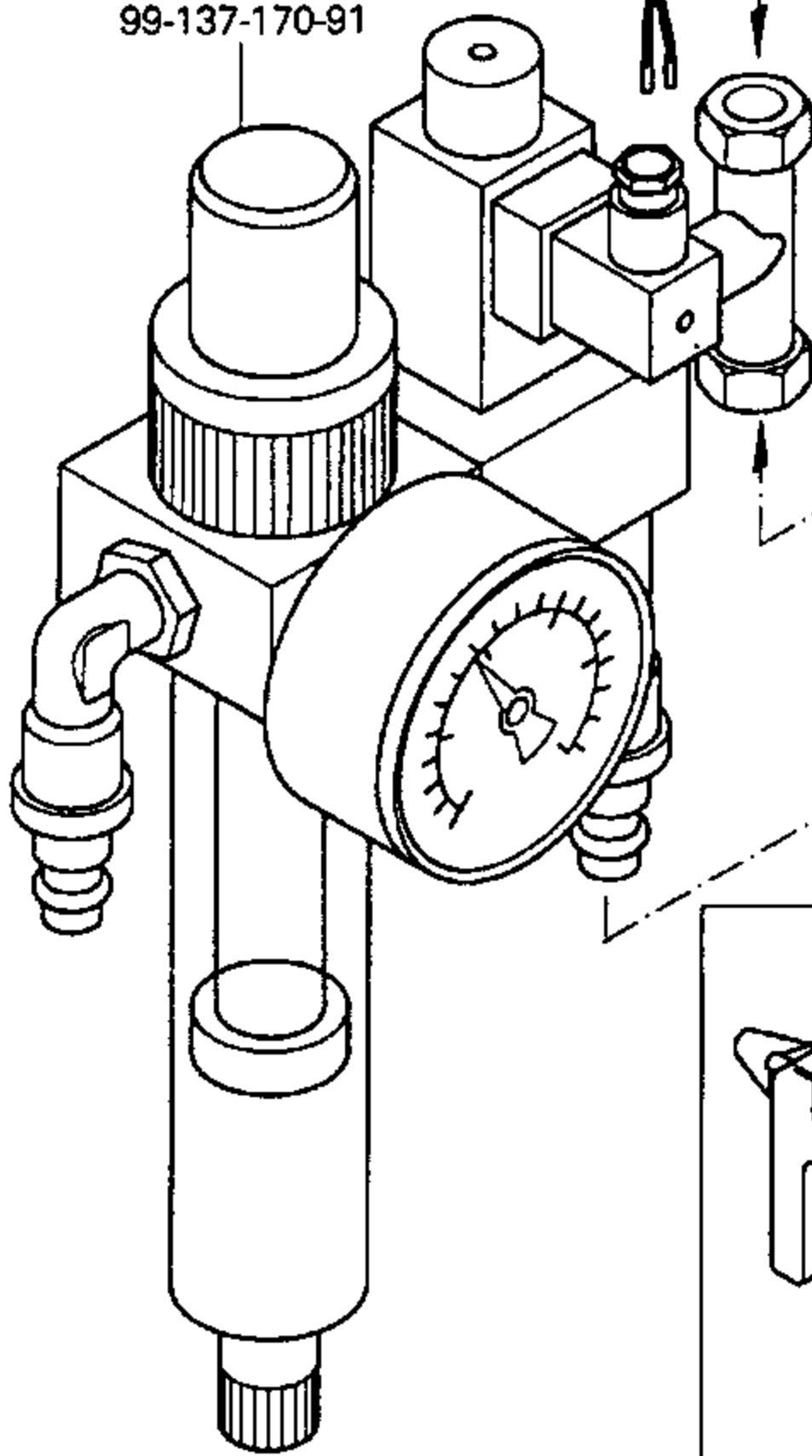

95-633 660-91

water bowl replacement is
 Mfg. part number
 FFG-A2-A+M

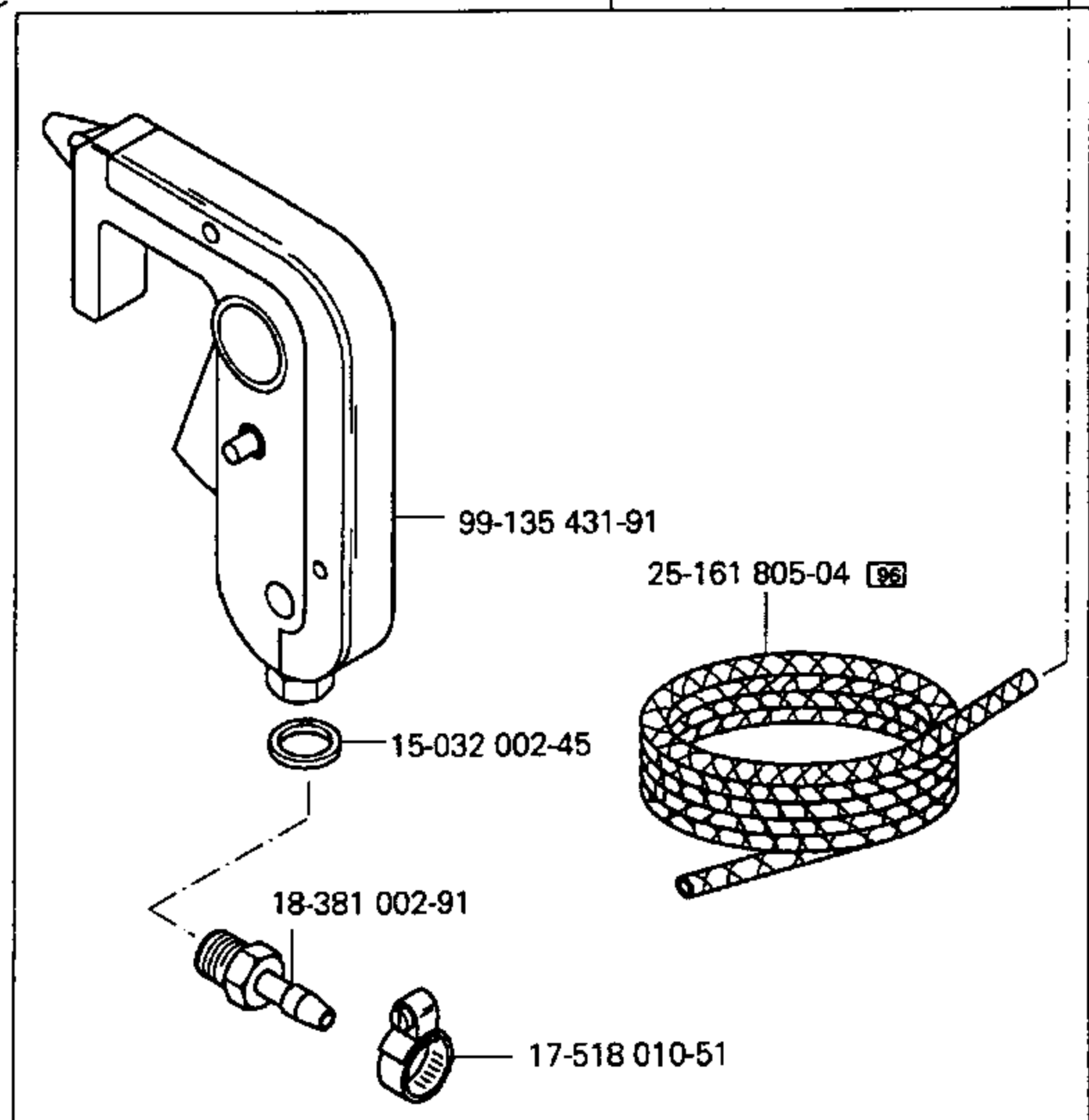

10.01

Bedienfeld
Control panel
Panneau de commande
Panel de mandos

PFAFF 3588-04/020

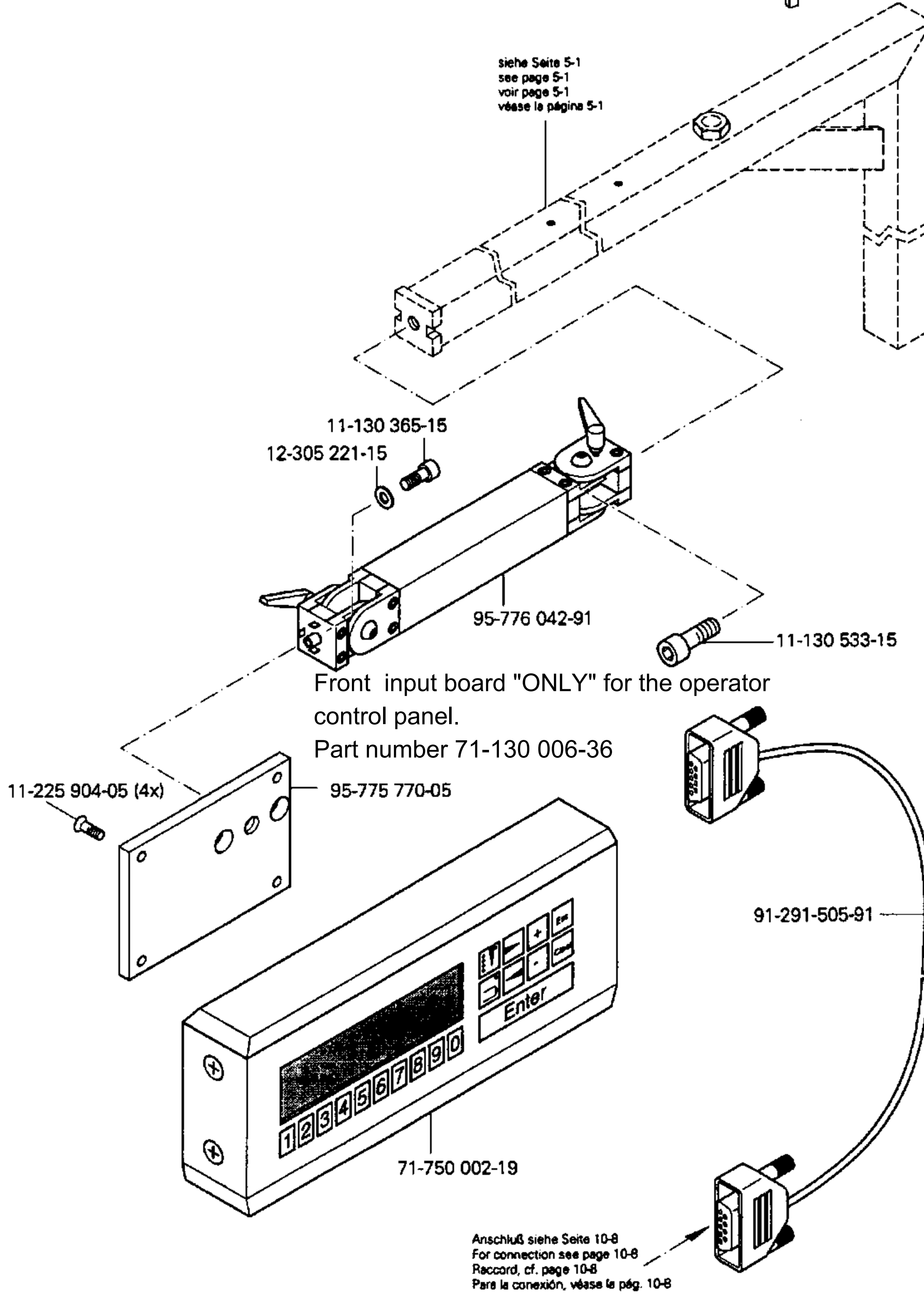
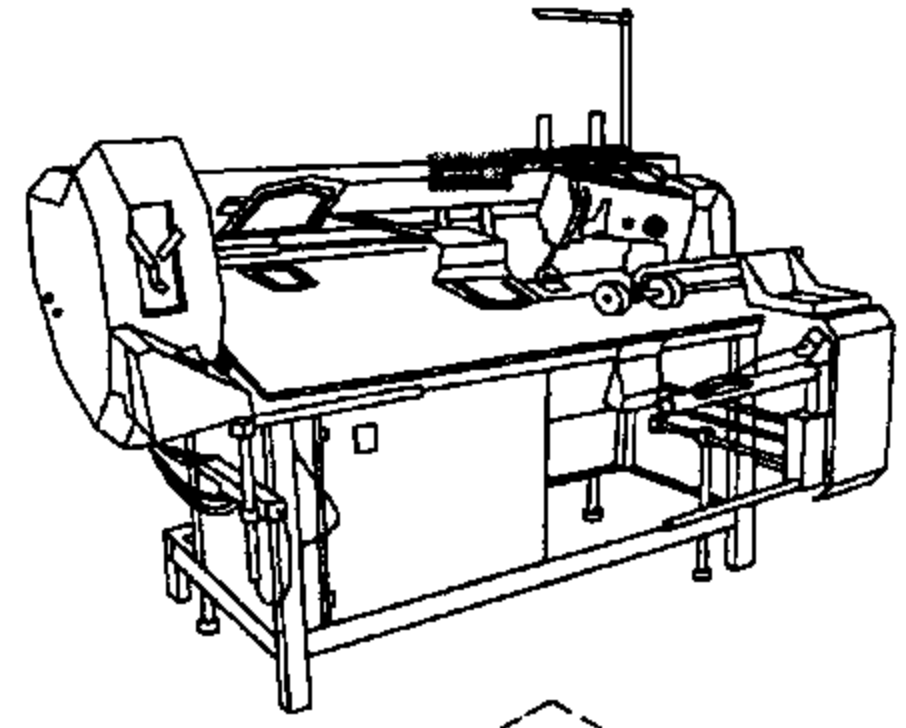

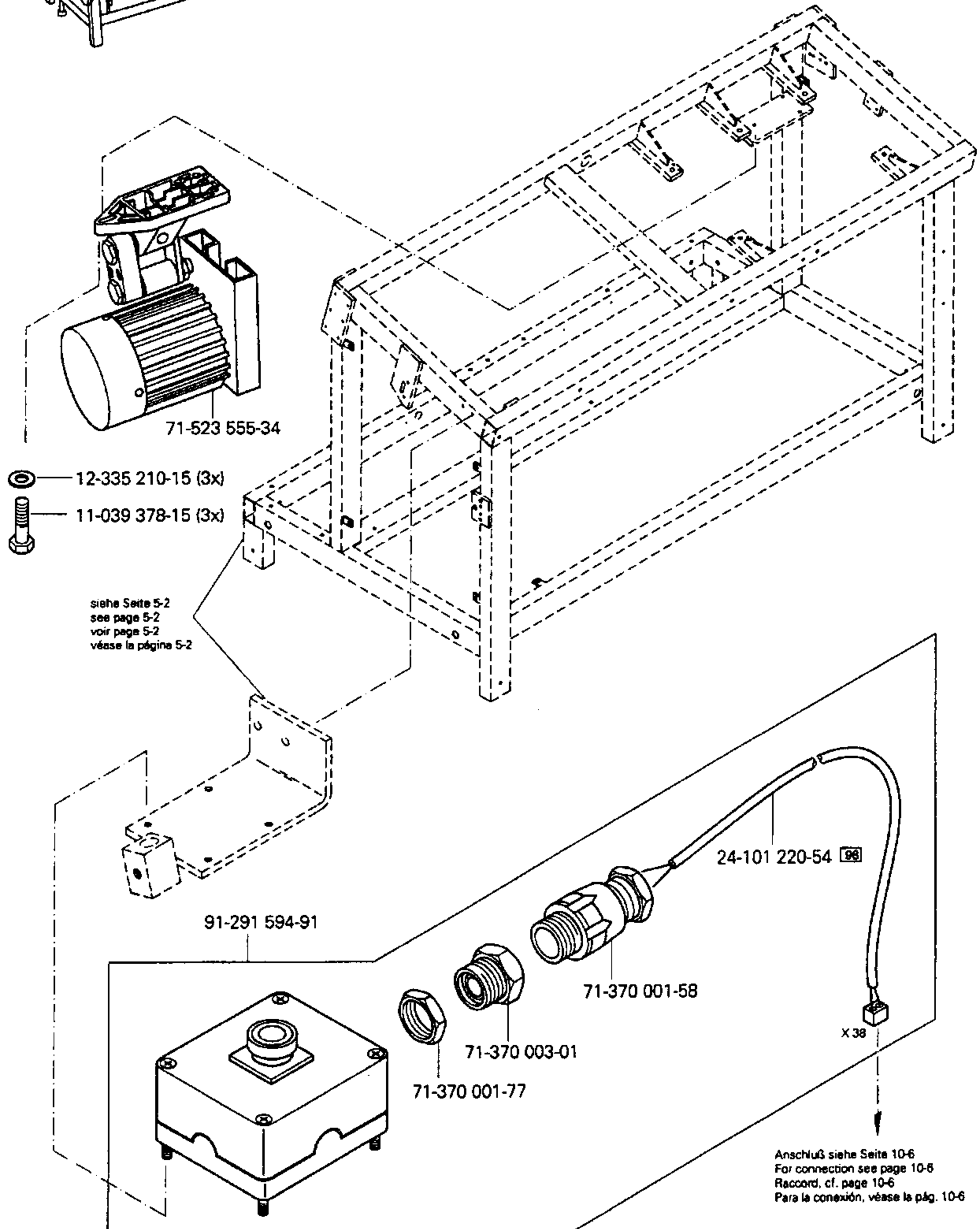
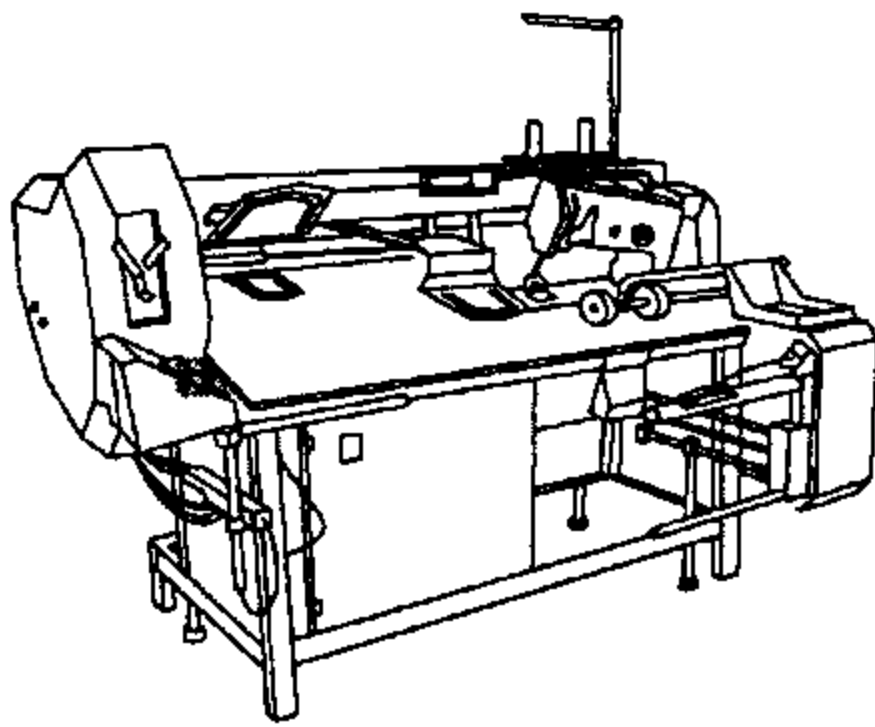

10.03

Zweihandbedienung
 Operation with both hands
 Commande à deux mains
 Manejo a dos manos

PFAFF 3588-04/020

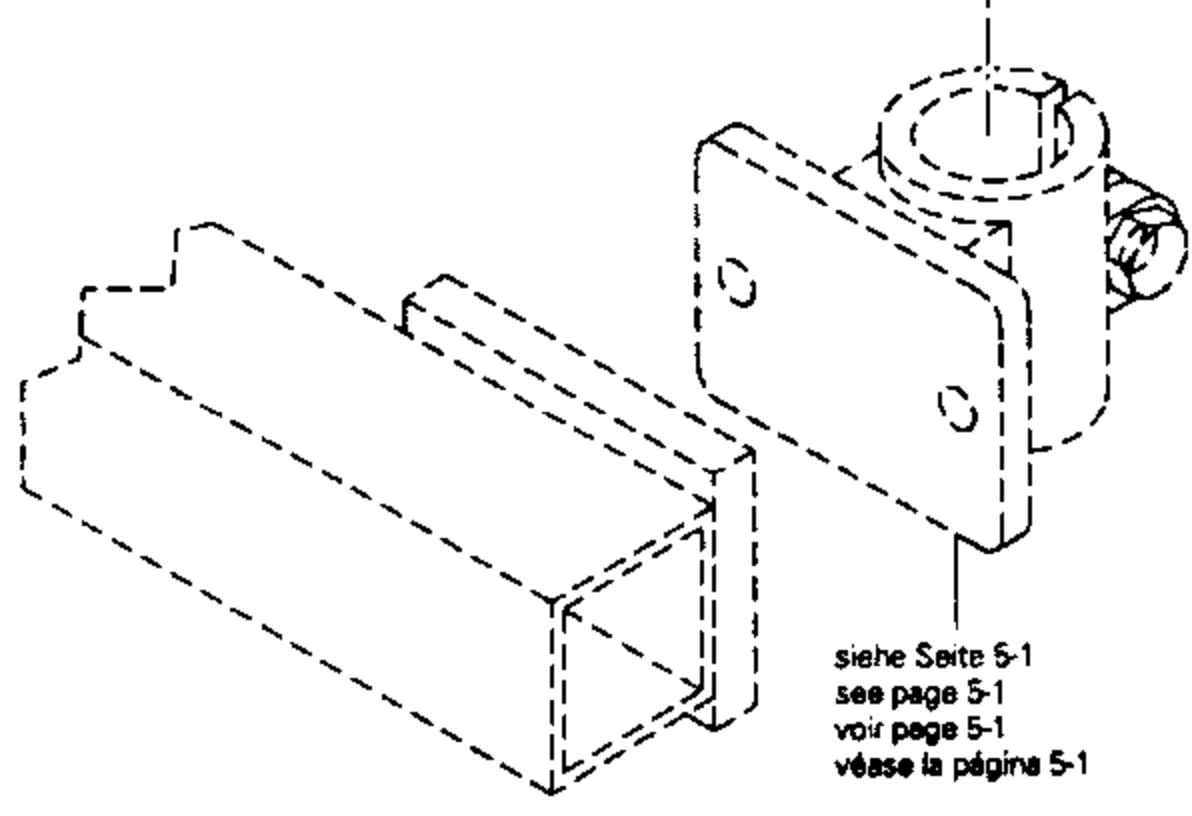
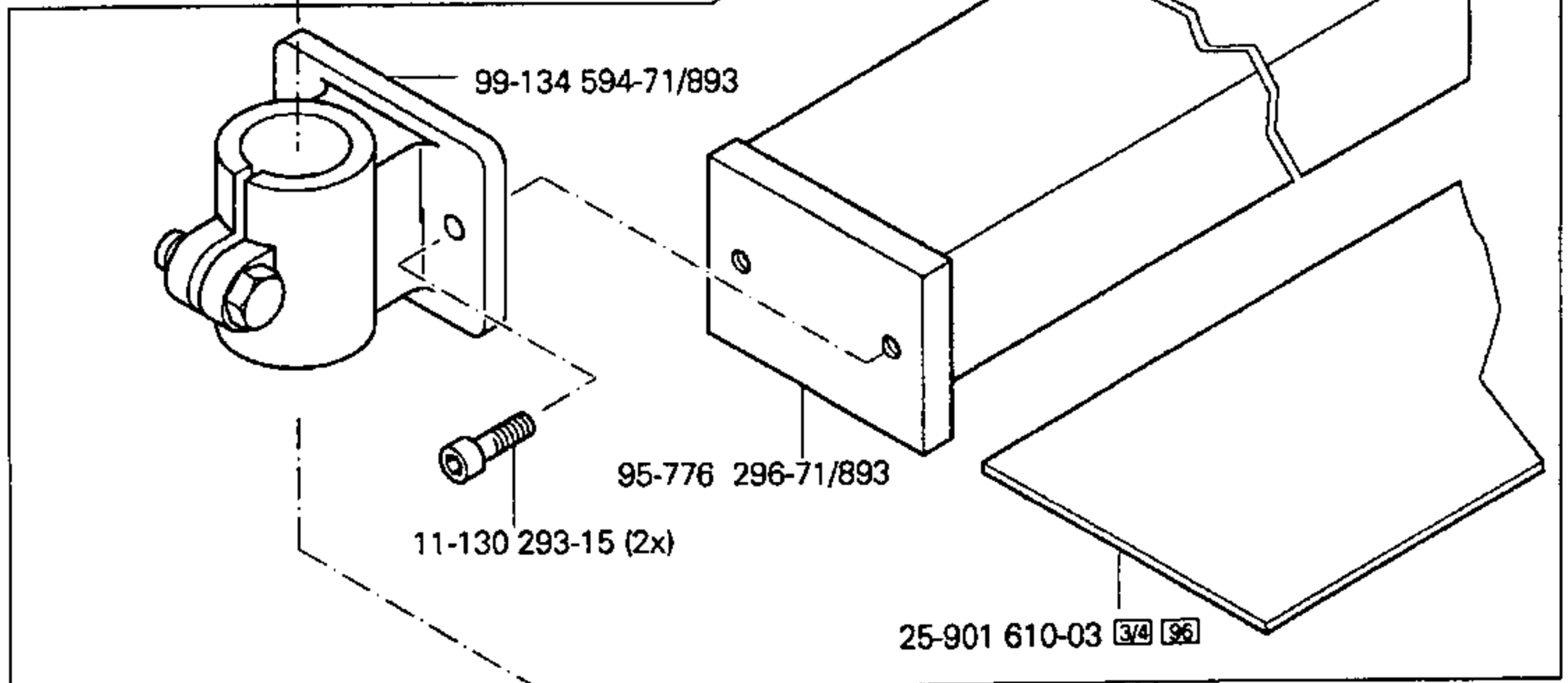
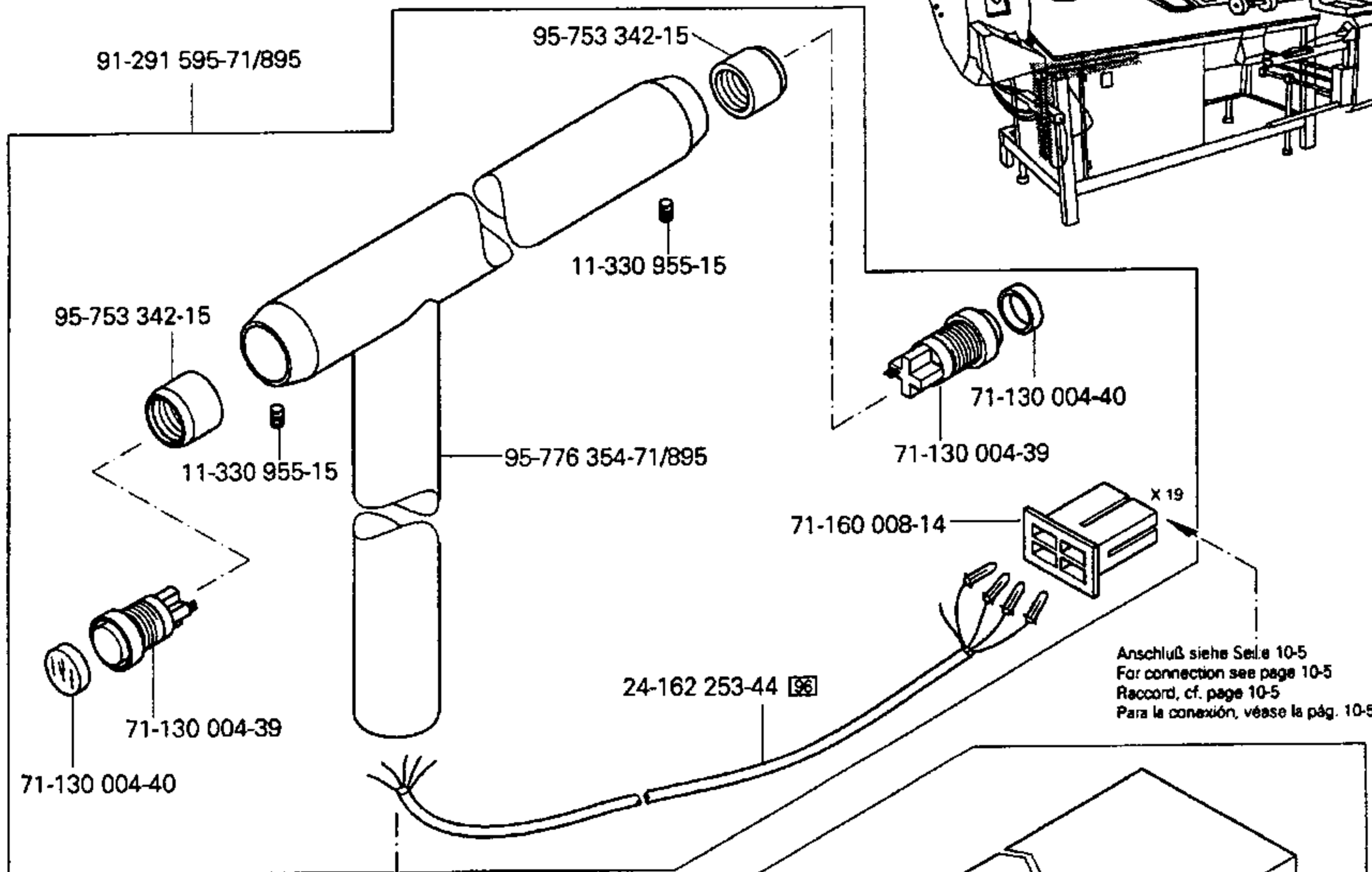
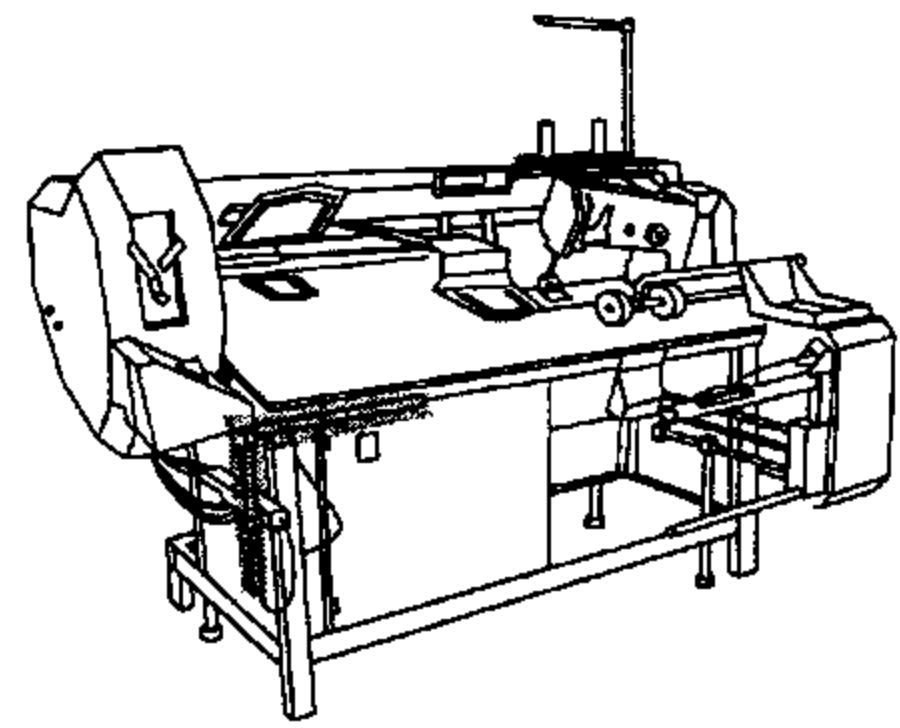

siehe Seite 5-1
 see page 5-1
 voir page 5-1
 véase la página 5-1

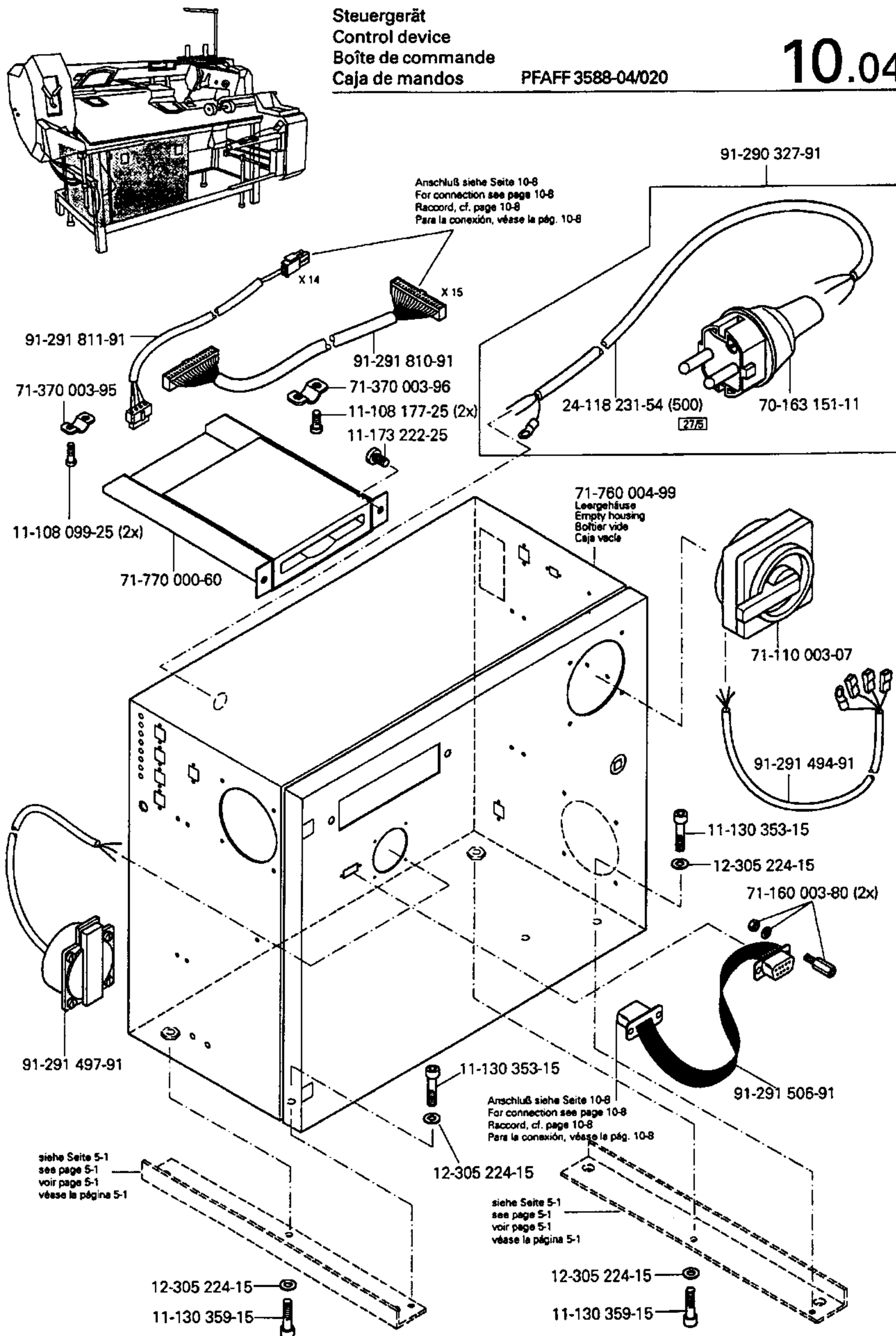

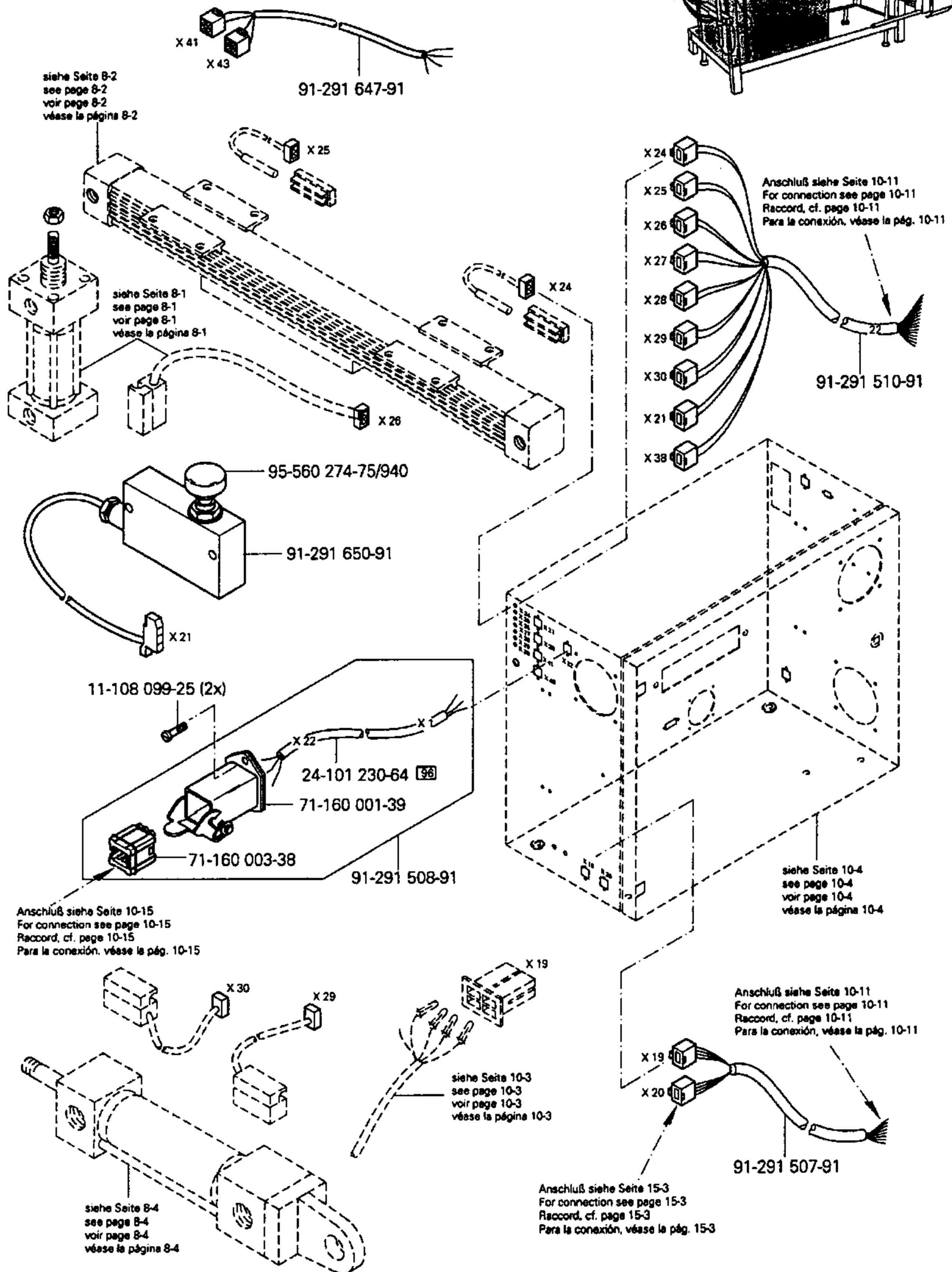
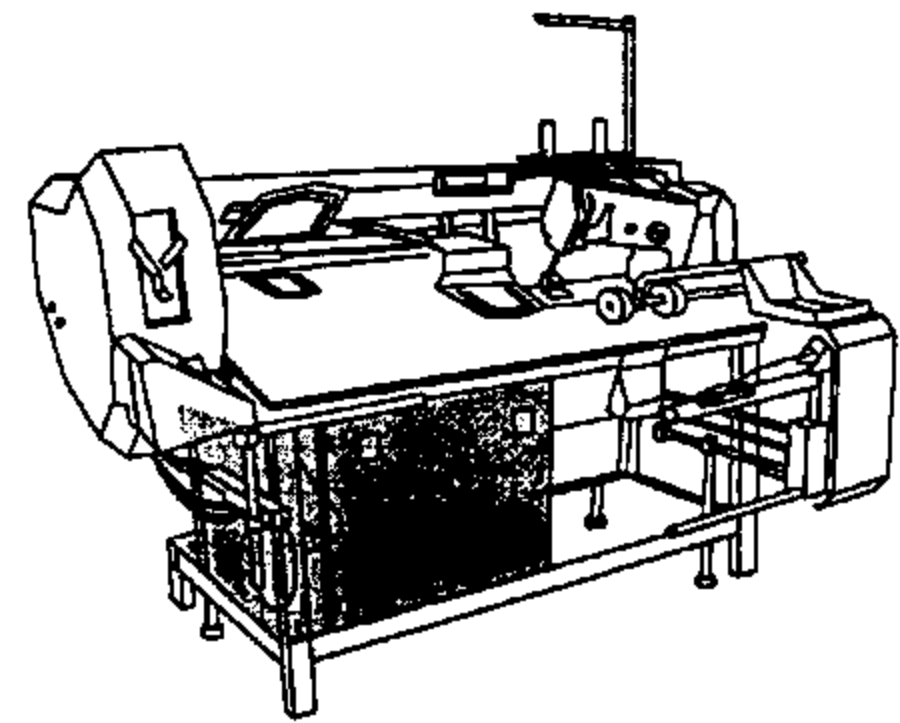

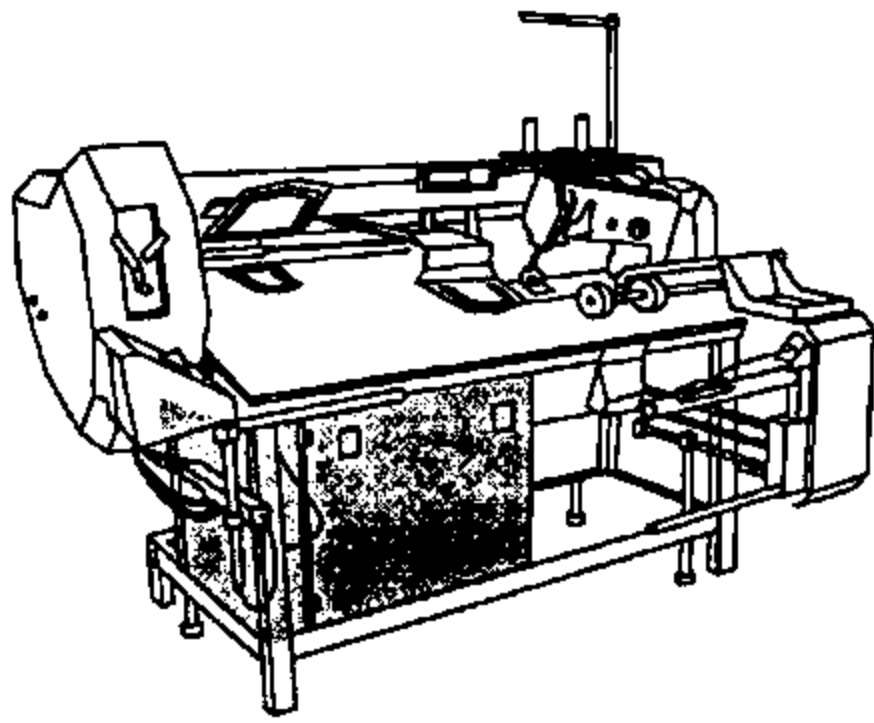

Steuergerät
Control device
Boîte de commande
Caja de mandos

PFAFF 3588-04/020

10.04

Anschluß siehe Seite 10-11
For connection see page 10-11
Raccord, cf. page 10-11
Para la conexión, véase la pág. 10-11

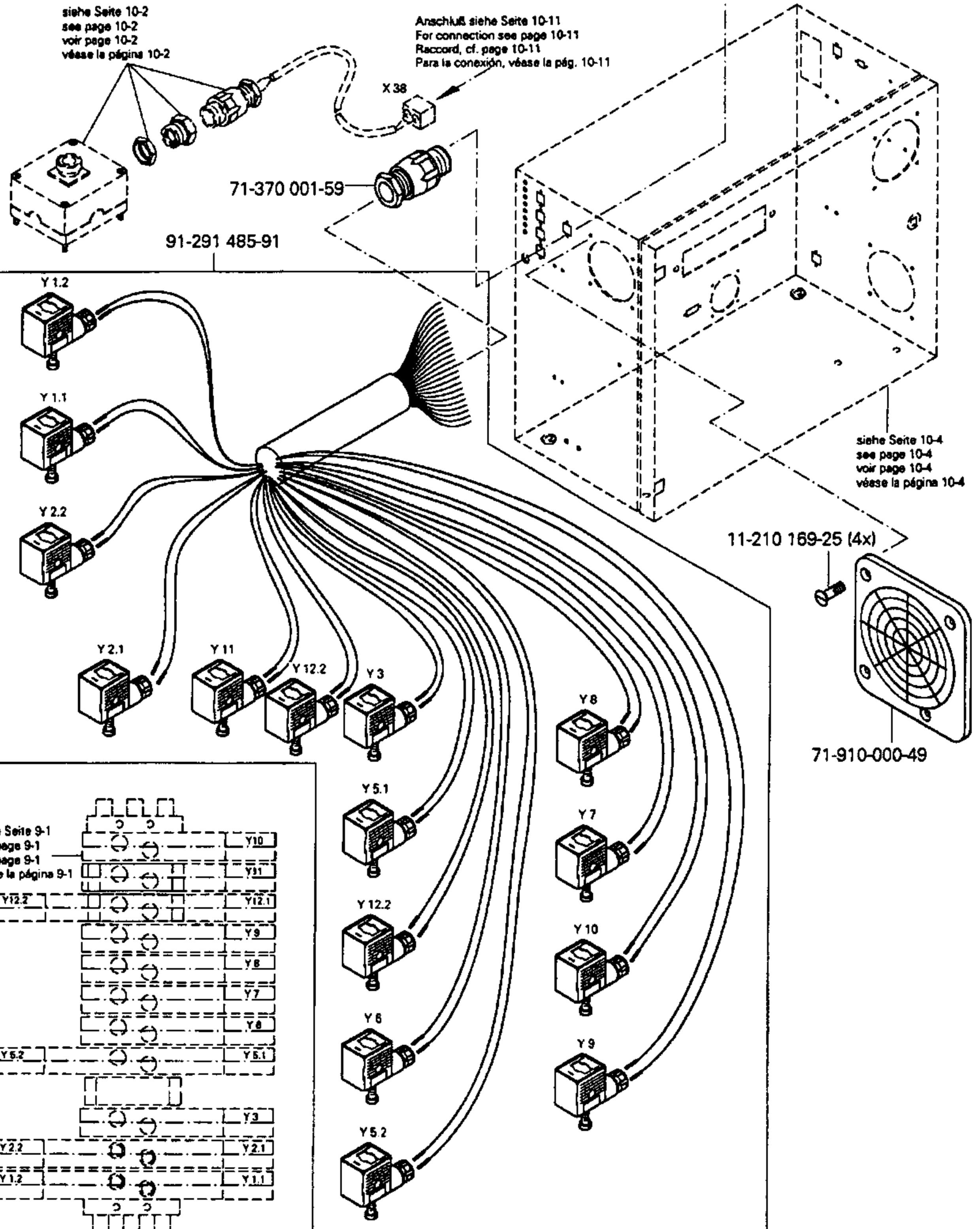

siehe Seite 9-1
see page 9-1
voir page 9-1
véase la página 9-1



PFAFF

☐ siehe Kapitel 2 Erläuterung der Schlüsselzeichen
see chapter 2 Explanation of key markings
voir le chap. 2 Explication des symboles
véase el Cap. 2 Explicaciones de los signos clave

10.04

Steuergerät
Control device
Boîte de commande
Caja de mandos

PFAFF 3588-04/020

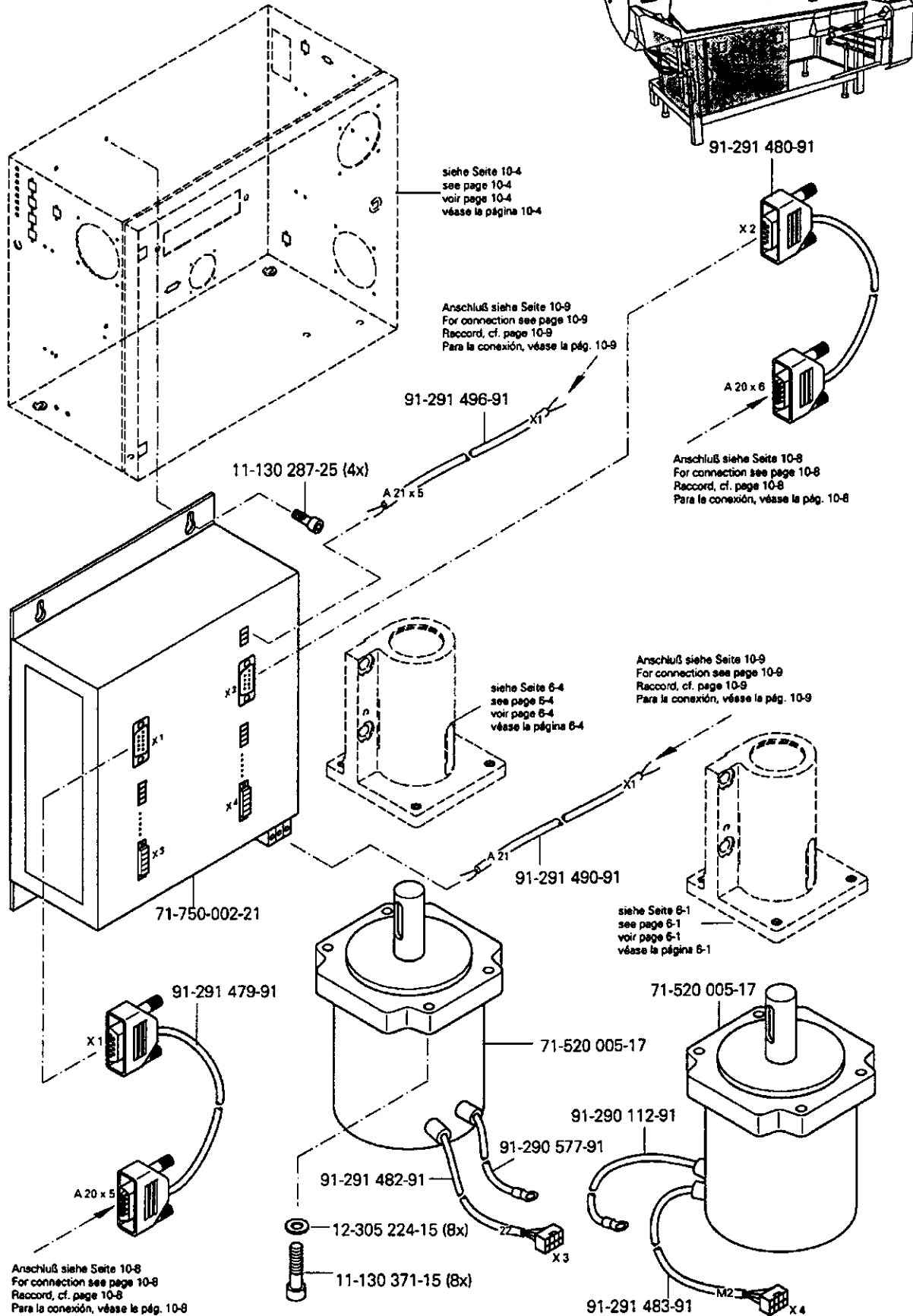

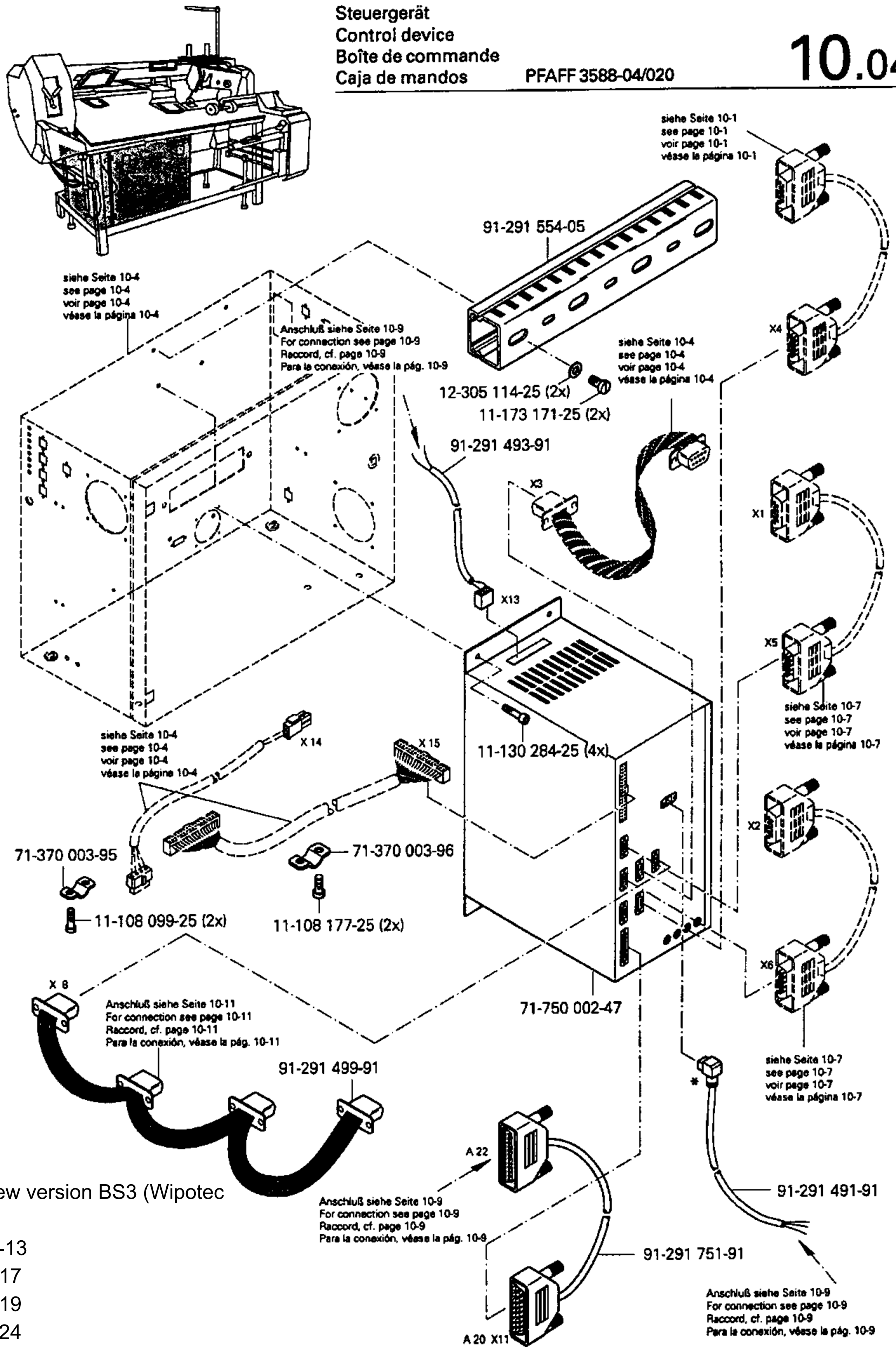

Fuses for the new version BS3 (Wipotec CPU)

- (1) 70-152 400-13
- (1) 70-152 400-17
- (1) 70-152 400-19
- (1) 70-152 400-24

Required for the P200

- (1) F550023

PFAFF

siehe Kapitel 2 Erläuterung der Schlüsselzeichen
 see chapter 2 Explanation of key markings
 voir le chap. 2 Explication des symboles
 véase el Cap. 2 Explicaciones de los signos clave

Fuses for the old version BS2 (Procom CPU)

- (1) 70-152 400-18
- (1) 70-152 400-21
- (1) 70-152 400-25

Pos.-Nr. Item No. N° pos. N° de pos.	Bestellnummer Part number N° de commande N° de pedido	Teile-Benennung Description Désignation Denominación	Pos.-Nr. Item No. N° pos. N° de pos.	Bestellnummer Part number N° de commande N° de pedido	Teile-Benennung Description Désignation Denominación
1	91-291 515-91	Montageplatte Mounting plate Plaque de montage Placa de montaje	17	71-590 007-11	Steuergerät P 200 Control unit Appareil de commande Aparato de mando
2	91-291 517-05	Kabelkanal Cable channel Canal de câbles Canal para cables	18	91-291 550-05	Kabelkanal Cable channel Canal de câbles Canal para cables
3	71-150 000-69	Sicherungsautomat 1 pol. 16 A Overload cutout, 1-pole Couple-circuit 1 pôle Fusible automático 1 polo	19	71-190 001-18	Relaisfassung Relay holder Douille du relais Portarrelés
4	11-173 171-25	Flachkopfschraube M4 x 6 Countersunk head screw Vis à tête plate Tornillo de cabeza plana	20	71-190 002-13	Haltebügel Retainer Etrier de maintien Estribo de sujecion
5	12-305 114-25	Scheibe A4,3 Washer Rondelle Arandela	21	71-190 000-60	Relais 24V Relay Relais Relé
6	91-290 319-45	Tragschiene Support rail Réglette de bornes Regleta portabornes	22	91-291 516-05	Tragschiene Support rail Réglette de bornes Regleta portabornes
7	11-210 165-15	Senkschraube M4 x 6 Countersunk screw Vis à tête noyée Tornillo avellanado	23	91-291 511-91	Leitung Tube Tuyau Tubo
8	71-210 002-21	Schutzleiterklemme Ground wire terminal Borne de terre Borne de puesta a tierra	24	91-291 489-91	Leitung Tube Tuyau Tubo
9	71-210 002-52	Anreihklemme Terminal strip Borne enfilable Borne	25	91-291 492-91	Leitung Tube Tuyau Tubo
10	71-210 002-50	Abschlußplatte Cover Plaque de fermeture Tapa	26	91-291 498-91	Leitung Tube Tuyau Tubo
11	71-210 002-40	Verbindungssteg Connector Barrette de jonction Clavija de unión	27	91-291 487-91	Leitung Tube Tuyau Tubo
12	71-480 000-12	Entstörfilter Suppressor Filtre antiparasites Filtro antiparásito	28	12-512 220-05	Scheibe A8,4 Washer Rondelle Arandela
13	91-291 549-05	Kabelkanal Cable channel Canal de câbles Canal para cables	29	12-005 215-15	Sechskantmutter M8 Hexagon nut Ecrou à six pans Tuerca hexagonal
14	91-291 586-93/001	Frequenzumrichter Frequency converter Changeur de fréquence Convertidor de frecuencias	30	71-710 000-82	Grenzwertmelder Limit indicator Indicateur de valeur Indicador valor lim.
15	11-130 299-25	Zylinderschraube M6 x 20 Pan-head screw Vis à tête cylindrique Tornillo cilindrico			
16	12-510 170-25	Scheibe A6,4 Washer Rondelle Arandela			

10.04

PFAFF



siehe Kapitel 2 Erläuterung der Schlüsselzeichen
see chapter 2 Explanation of key markings
voir le chap. 2 Explication des symboles
véase el Cap. 2 Explicaciones de los signos clave

10 - 10

10.04

Steuergerät
Control device
Boîte de commande
Caja de mandos

PFAFF 3588-04/020

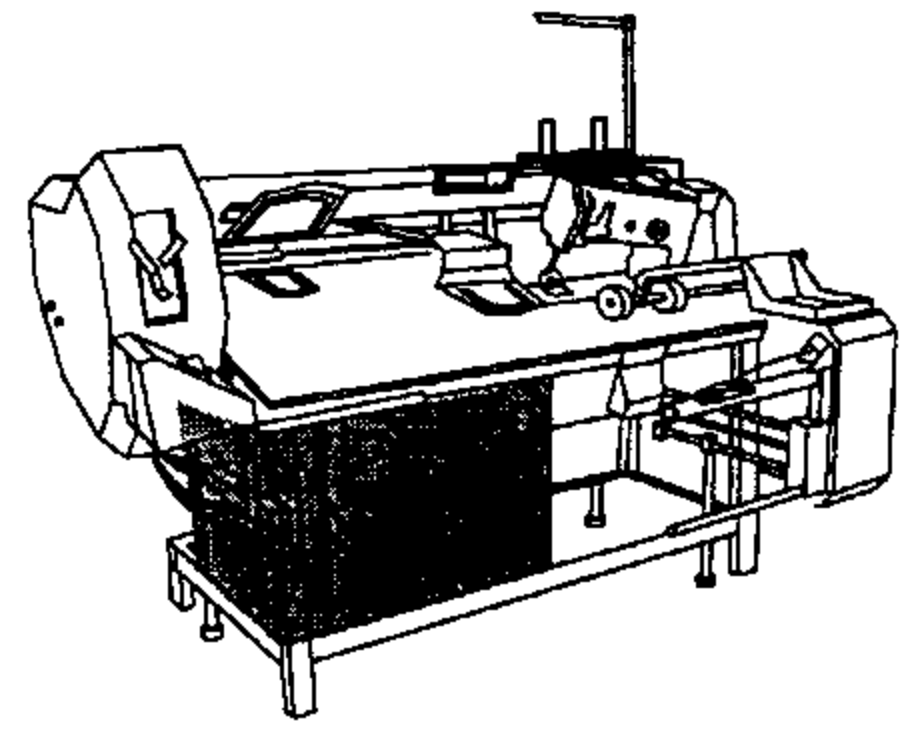

siehe Seite 3-23
see page 3-23
voir page 3-23
véase la página 3-23



siehe Seite 6-6
see page 6-6
voir page 6-6
véase la página 6-6

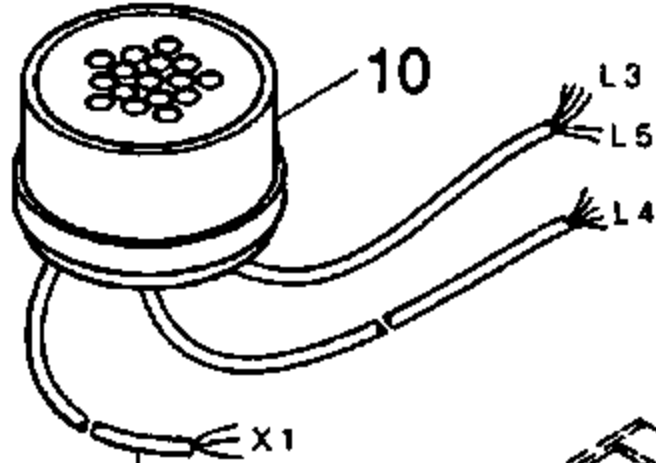
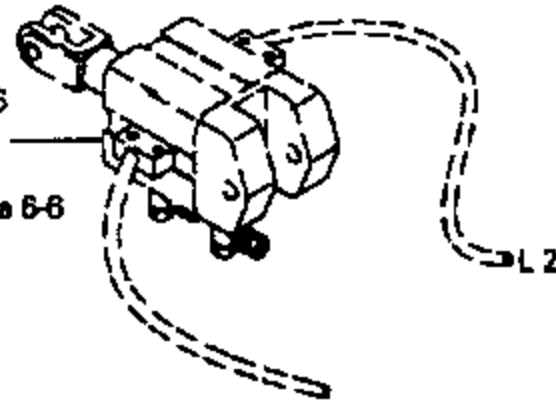

siehe Seite 9-6
see page 9-6
voir page 9-6
véase la página 9-6

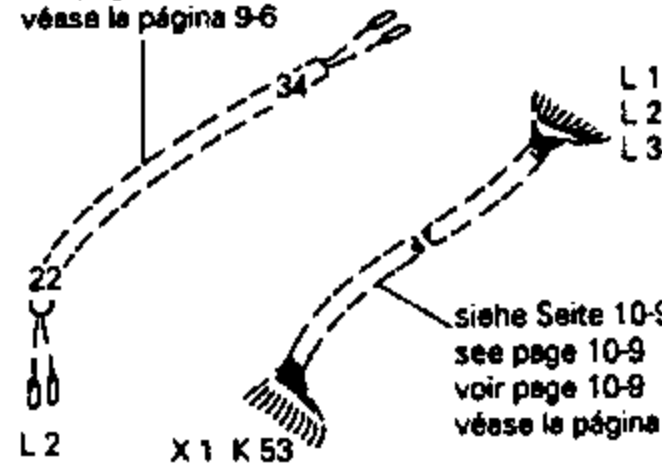

siehe Seite 10-5
see page 10-5
voir page 10-5
véase la página 10-5

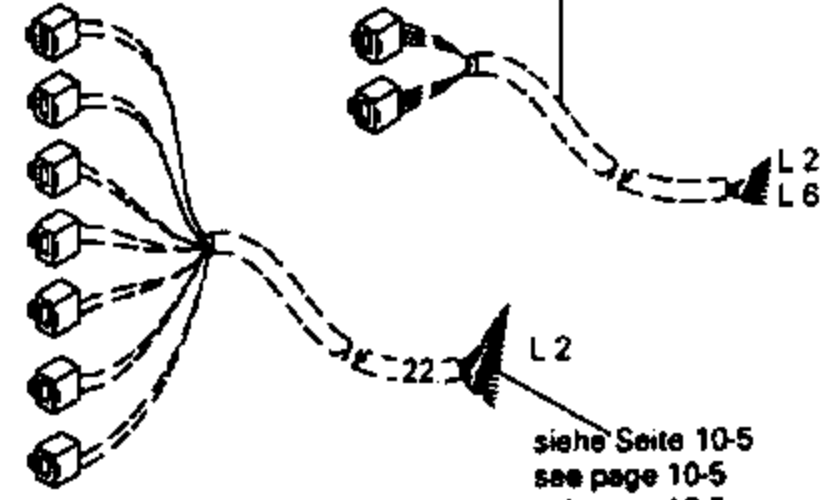

siehe Seite 10-9
see page 10-9
voir page 10-9
véase la página 10-9

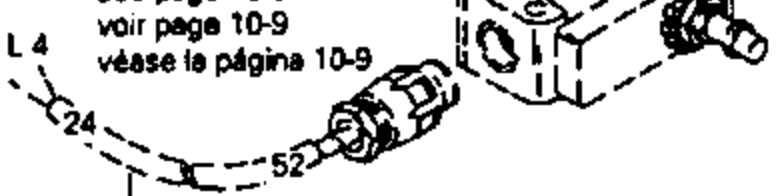

siehe Seite 10-9
see page 10-9
voir page 10-9
véase la página 10-9

siehe Seite 10-5
see page 10-5
voir page 10-5
véase la página 10-5

siehe Seite 7-6
see page 7-6
voir page 7-6
véase la página 7-6

siehe Seite 10-9
see page 10-9
voir page 10-9
véase la página 10-9

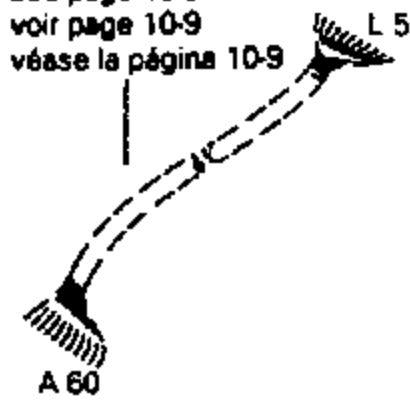

siehe Seite 10-8
see page 10-8
voir page 10-8
véase la página 10-8

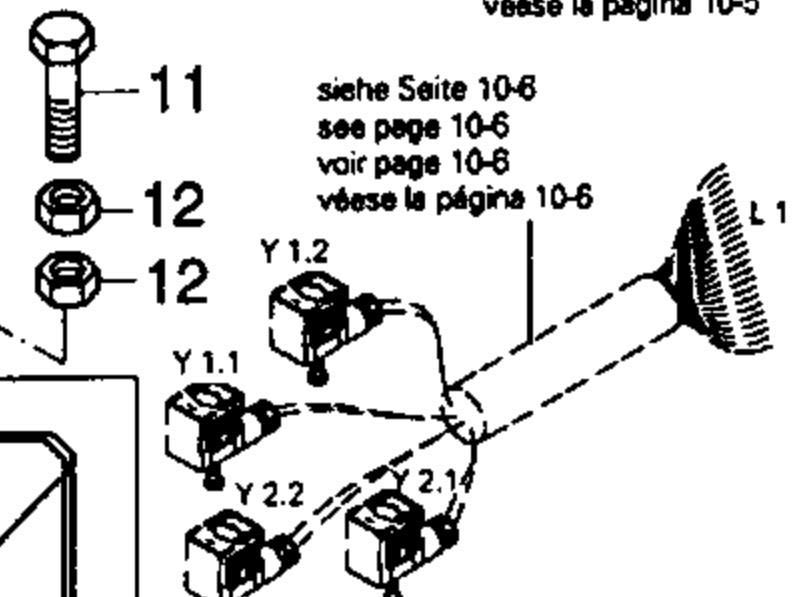
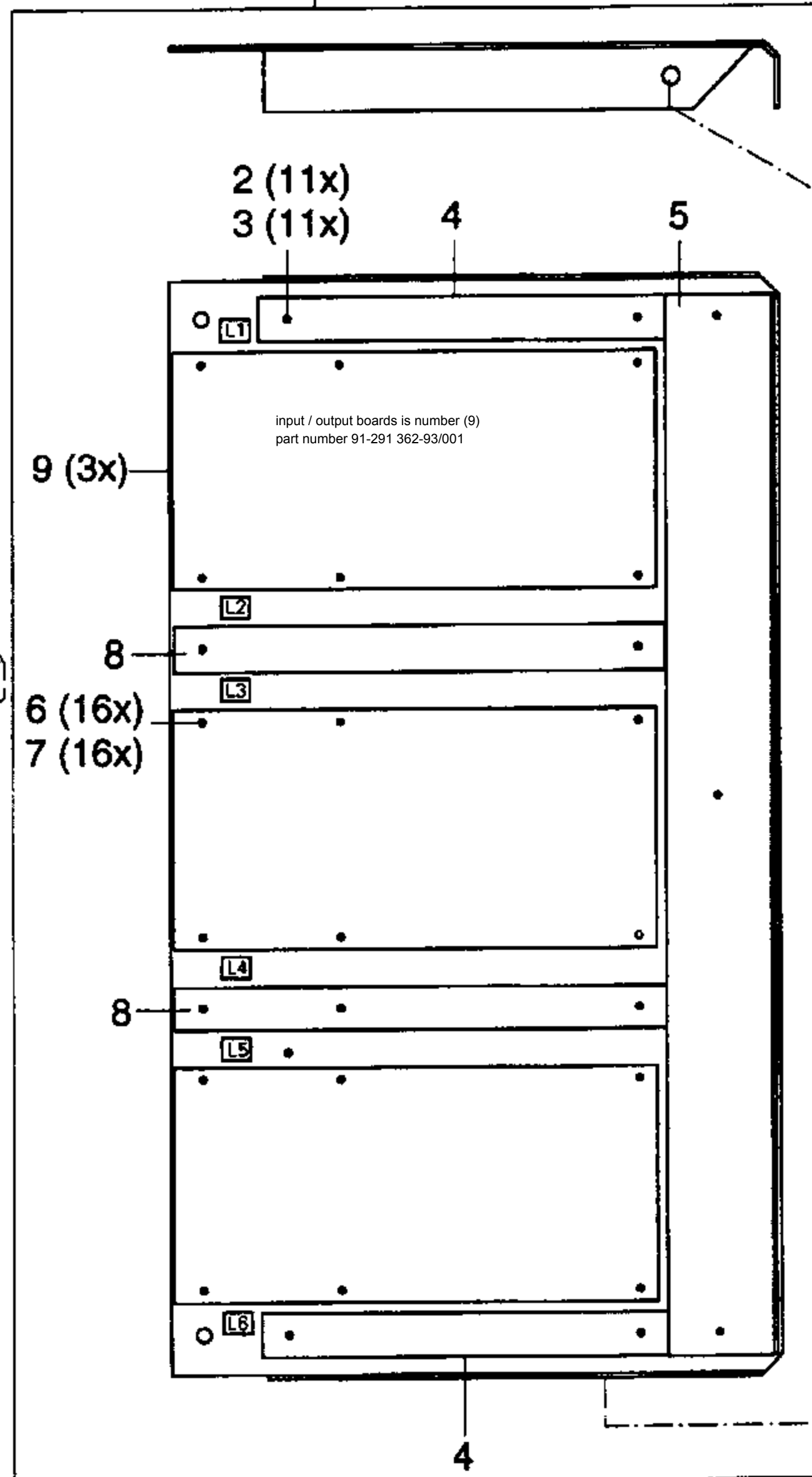
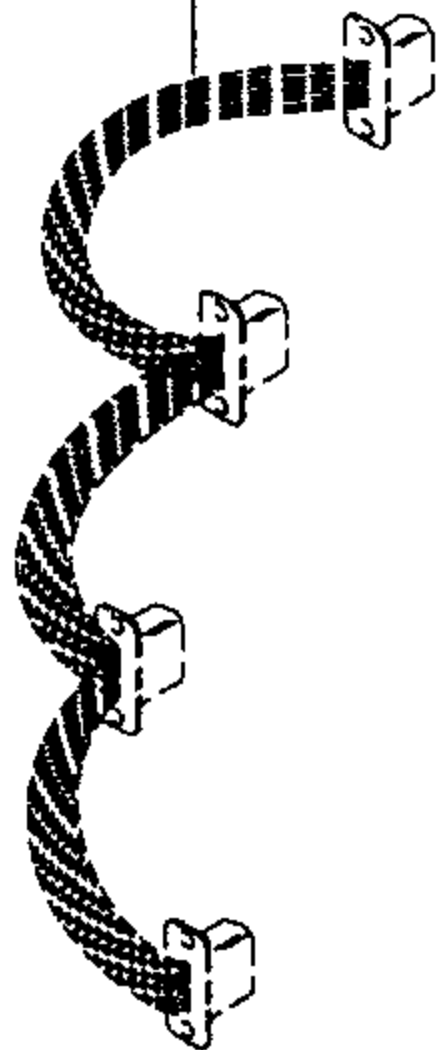

siehe Seite 10-6
see page 10-6
voir page 10-6
véase la página 10-6

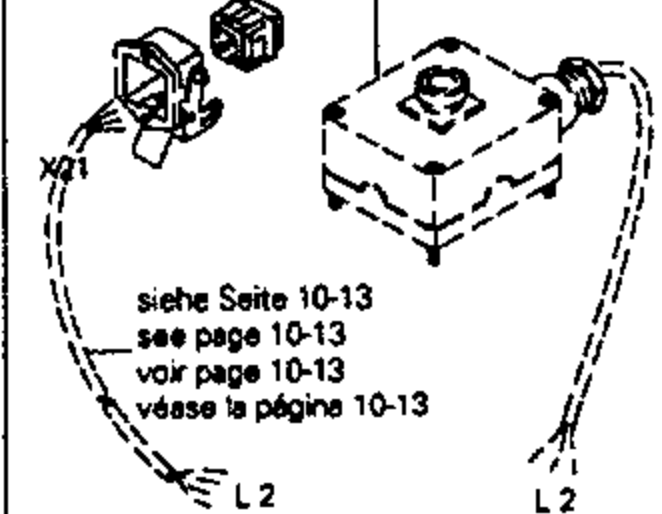

siehe Seite 10-13
see page 10-13
voir page 10-13
véase la página 10-13

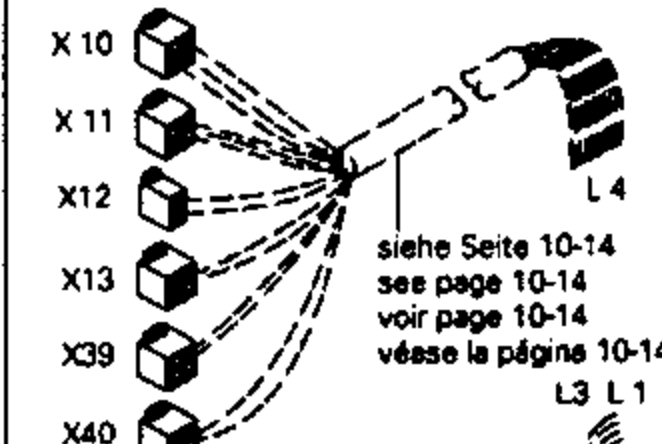

siehe Seite 10-14
see page 10-14
voir page 10-14
véase la página 10-14

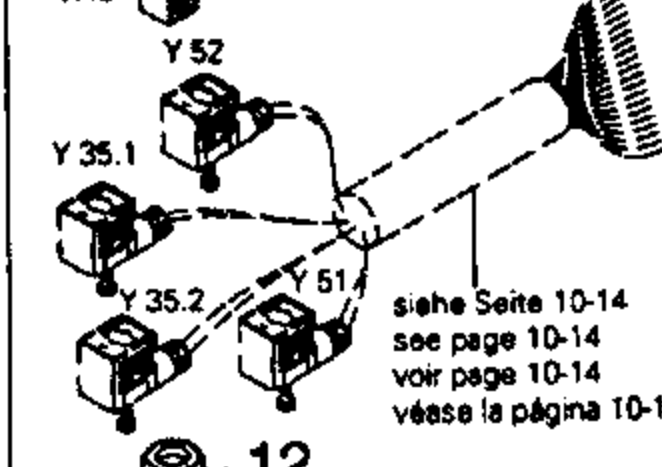

siehe Seite 10-14
see page 10-14
voir page 10-14
véase la página 10-14

Pos.-Nr. Item No. N° pos. N° de pos.	Bestellnummer Part number N° de commande N° de pedido	Teile-Benennung Description Désignation Denominación	Pos.-Nr. Item No. N° pos. N° de pos.	Bestellnummer Part number N° de commande N° de pedido	Teile-Benennung Description Désignation Denominación
1	91-291 514-91	Montageplatte Mounting plate Plaque de montage Placa de montaje			
2	11-178 166-25	Flachkopfschraube M4 x 5 Countersunk head screw Vis à tête plate Tornillo de cabeza plana			
3	12-305 114-15	Scheibe A4,3 Washer Rondelle Arandela			
4	91-291 552-05	Kabelkanal Cable channel Canal de câbles Canal para cables			
5	91-291 551-05	Kabelkanal Cable channel Canal de câbles Canal para cables			
6	11-108 093-25	Zylinderschraube M3 x 6 Pan-head screw Vis à tête cylindrique Tornillo cilíndrico			
7	11-724 160-55	Abstandsbolzen M3 x 12 Spacing stud Boulon d'écartement Perno distancador			
8	91-291 553-05	Kabelkanal Cable channel Canal de câbles Canal para cables			
9	91-291 362-93/001	Bestückte Leiterplatte DX 353 Solid state circuit board Carte imprimée équipée Placa de circuito impreso			
10	91-291 503-91	Leitung Tube Tuyau Tubo			
11	11-039 354-15	Sechskantschraube M8 x 12 Hexagon screw Vis à six pans Tornillo hexagonal			
12	12-005 215-15	Sechskantmutter M8 Hexagon nut Ecrou à six pans Tuerca hexagonal			

10.04

PFAFF



siehe Kapitel 2 Erläuterung der Schlüsselzeichen
see chapter 2 Explanation of key markings
voir le chap. 2 Explication des symboles
véase el Cap. 2 Explicaciones de los signos clave

10 - 12

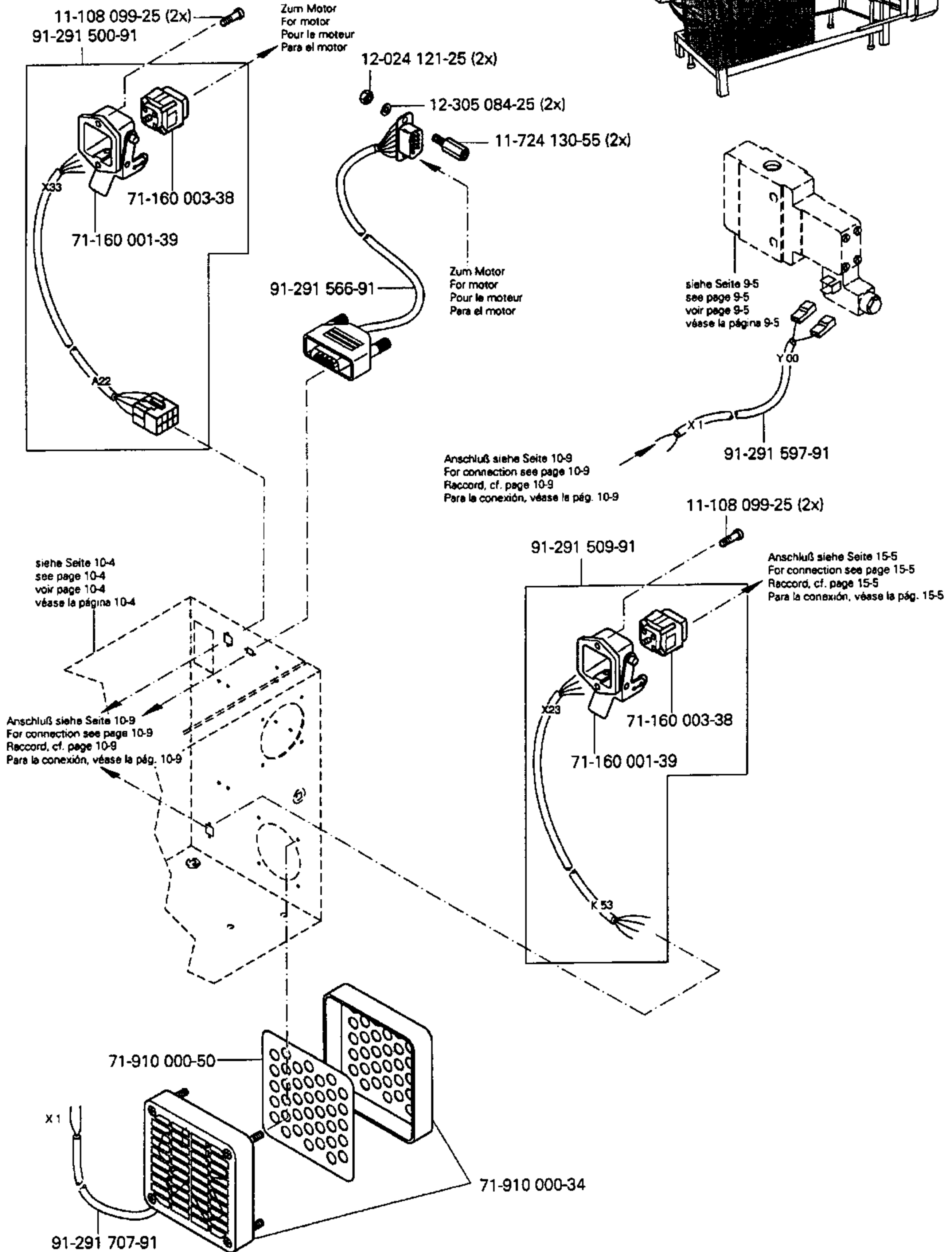
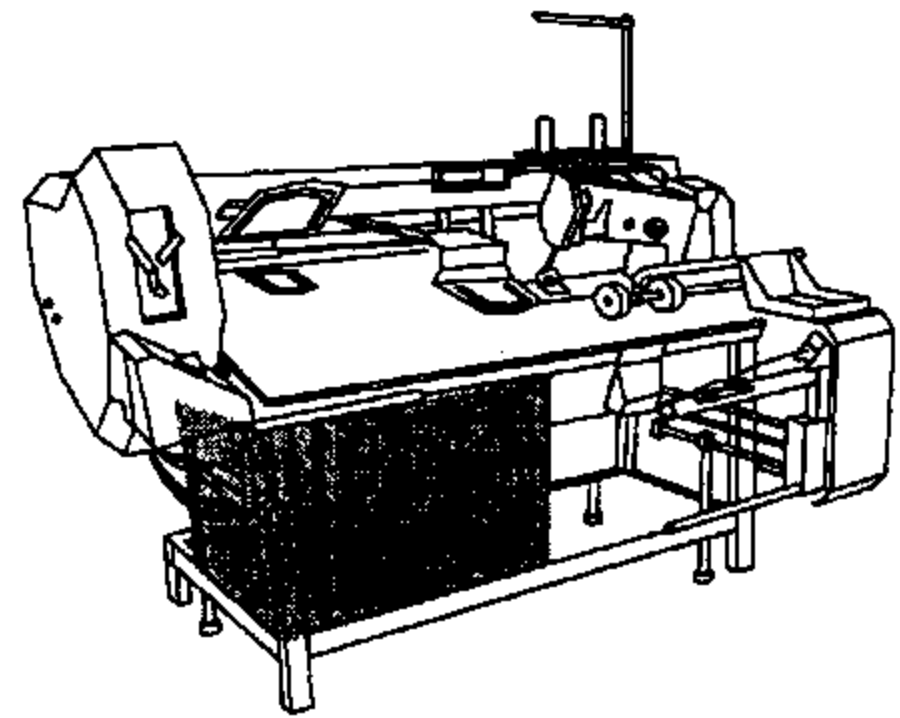

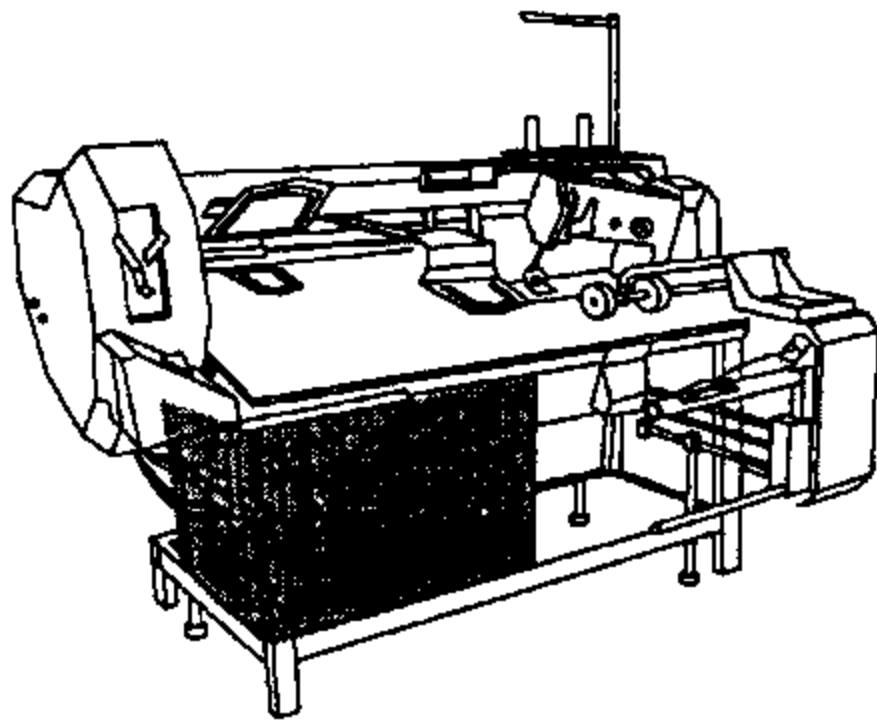

Steuergerät
Control device
Boîte de commande
Caja de mandos

PFAFF 3588-04/020

10.04

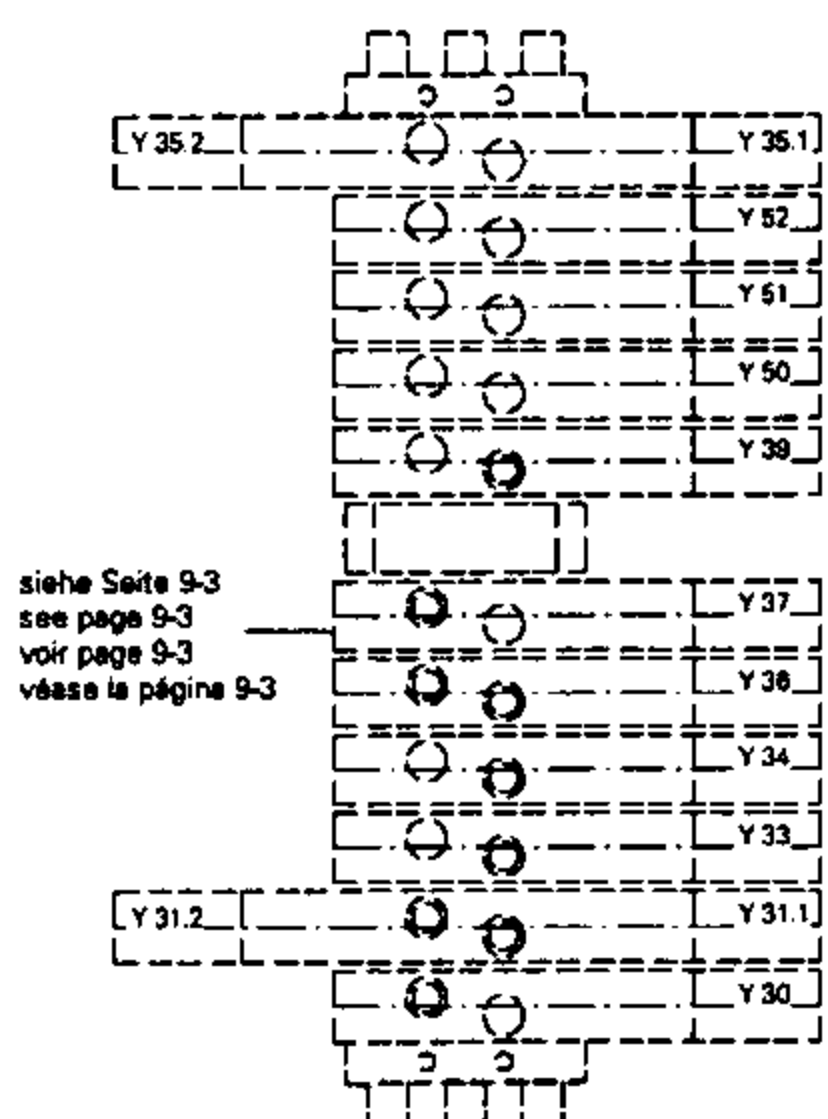
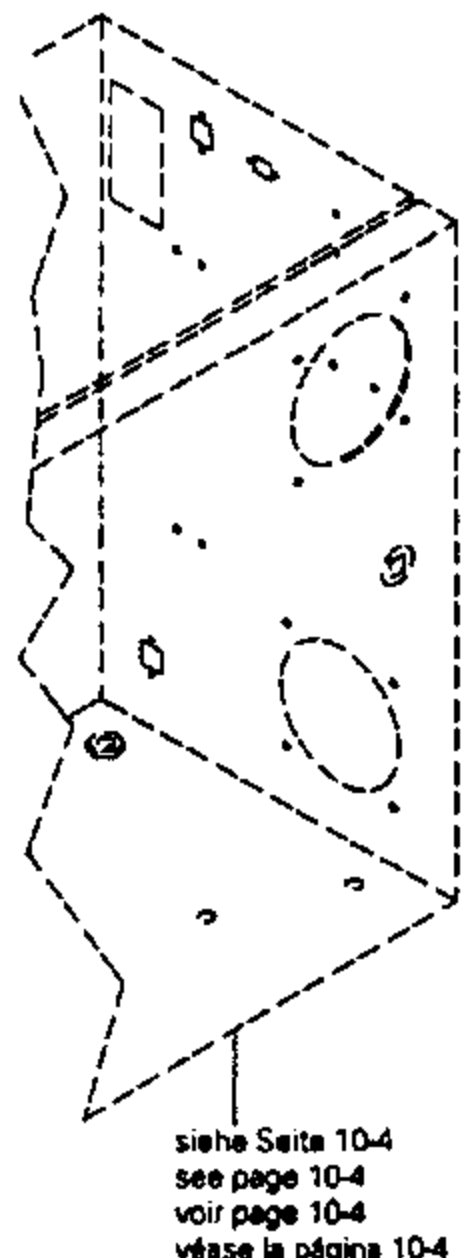
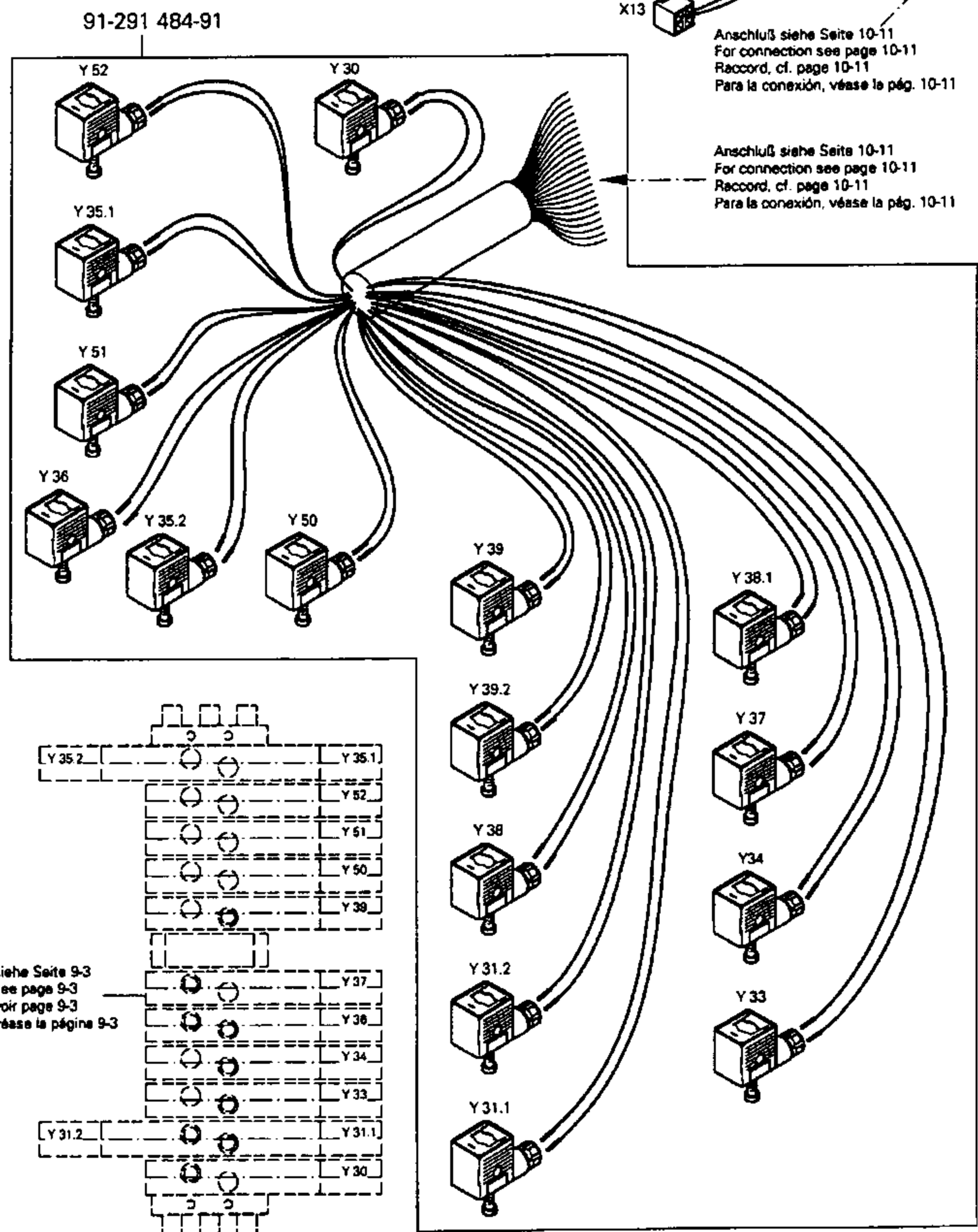
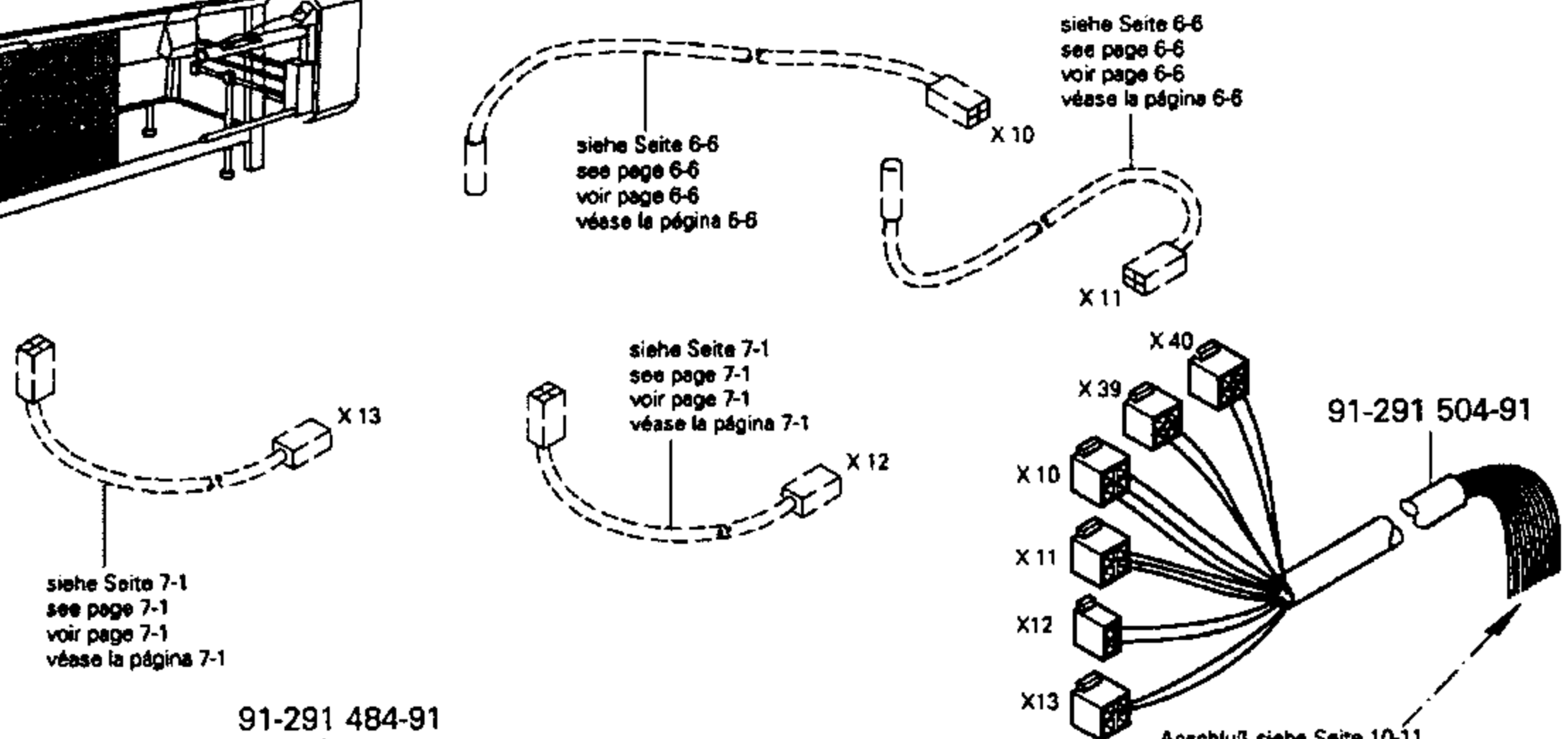

10.05

Saugeinrichtung
 Vacuum system
 Dispositif d'aspiration
 Dispositivo de aspiración PFAFF 3588-04/020

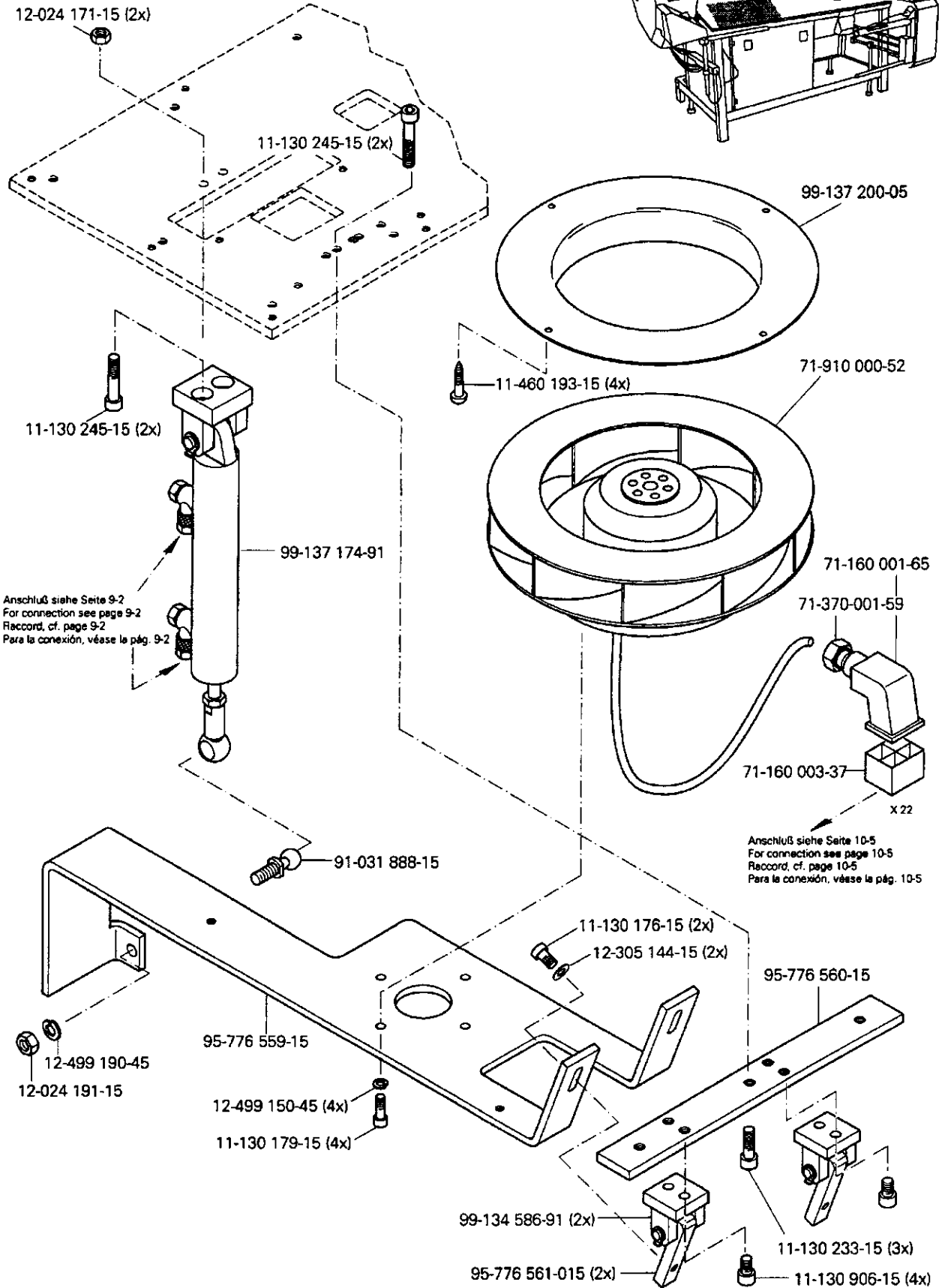
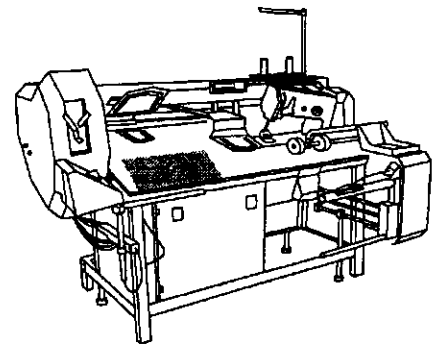

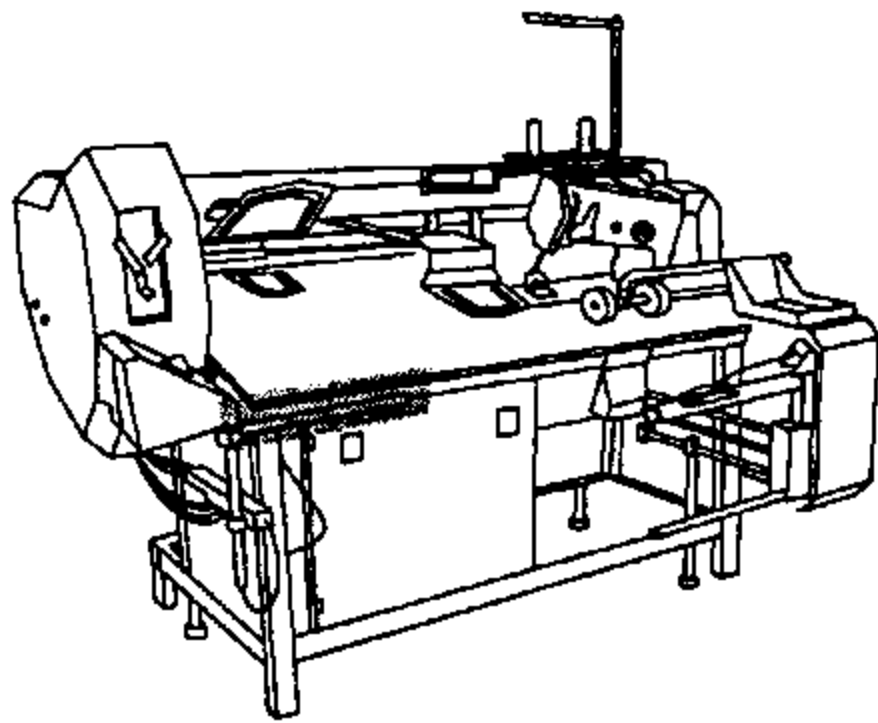

Stoffrückhaltevorrichtung
 Workpiece retainer
 Dispositif de rétension du tissu
 Dispositivo de retención del material PFAFF 3588-04/020

10.06

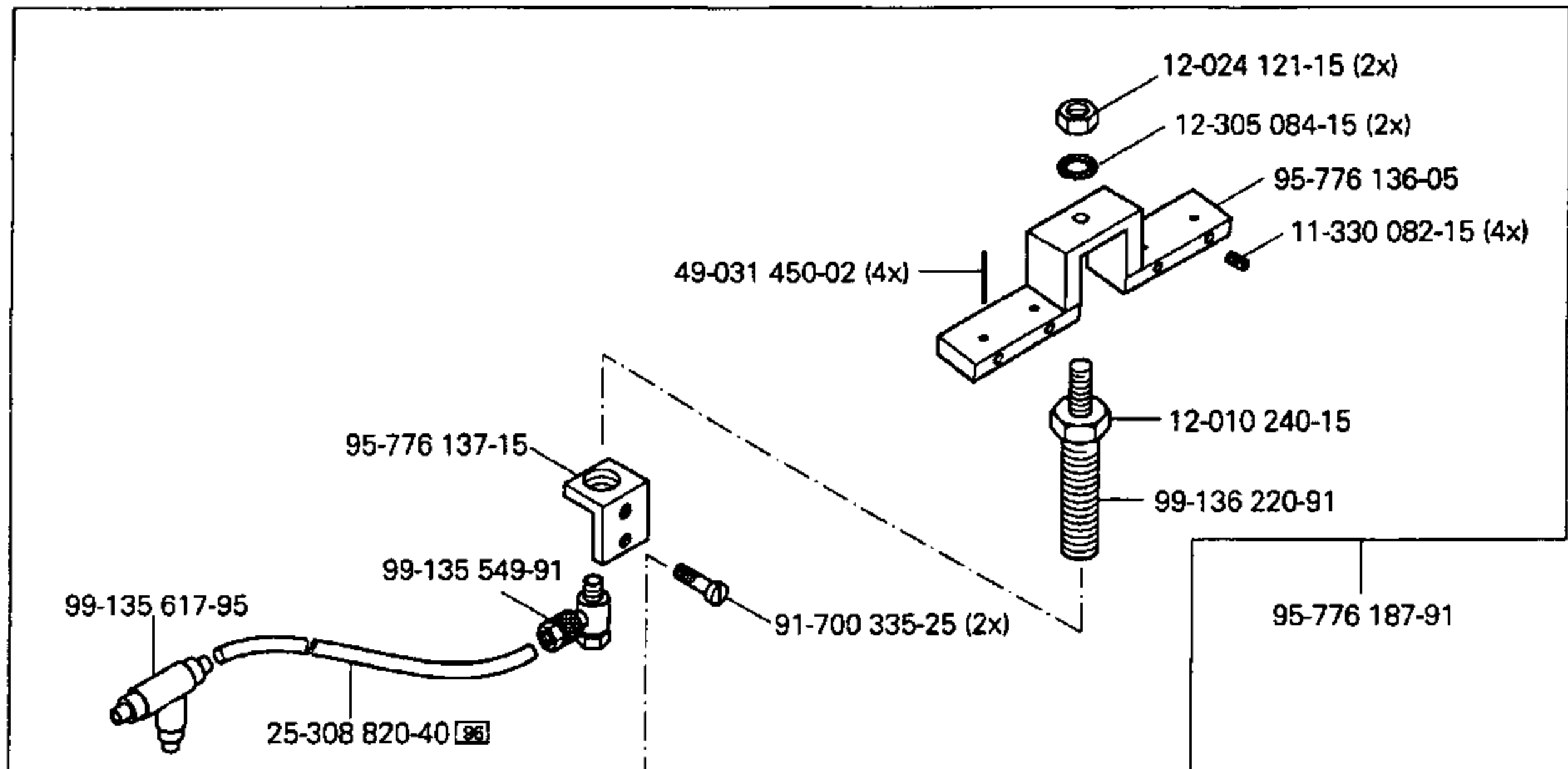

siehe Seite 4-1
 see page 4-1
 voir page 4-1
 véase la página 4-1

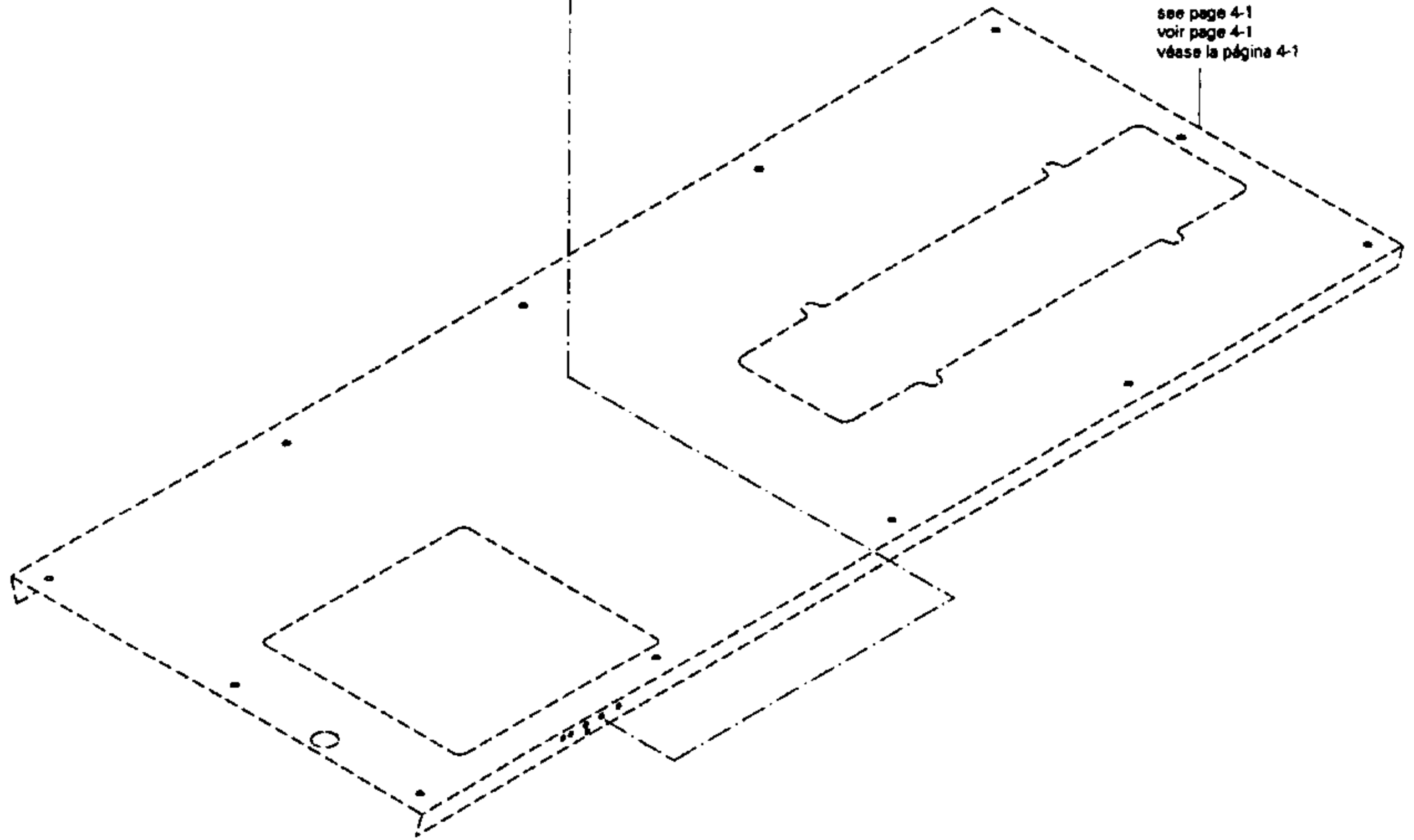

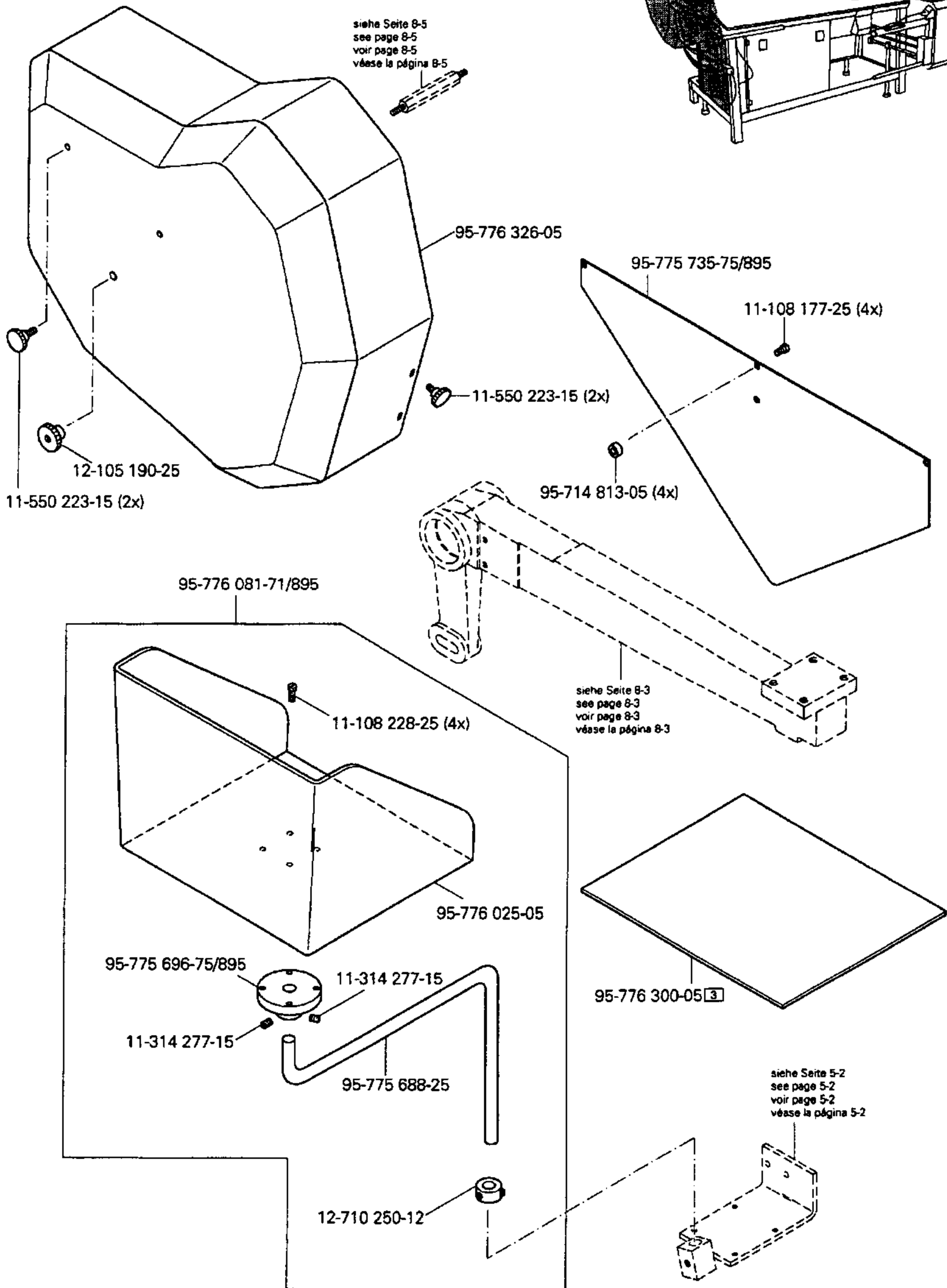
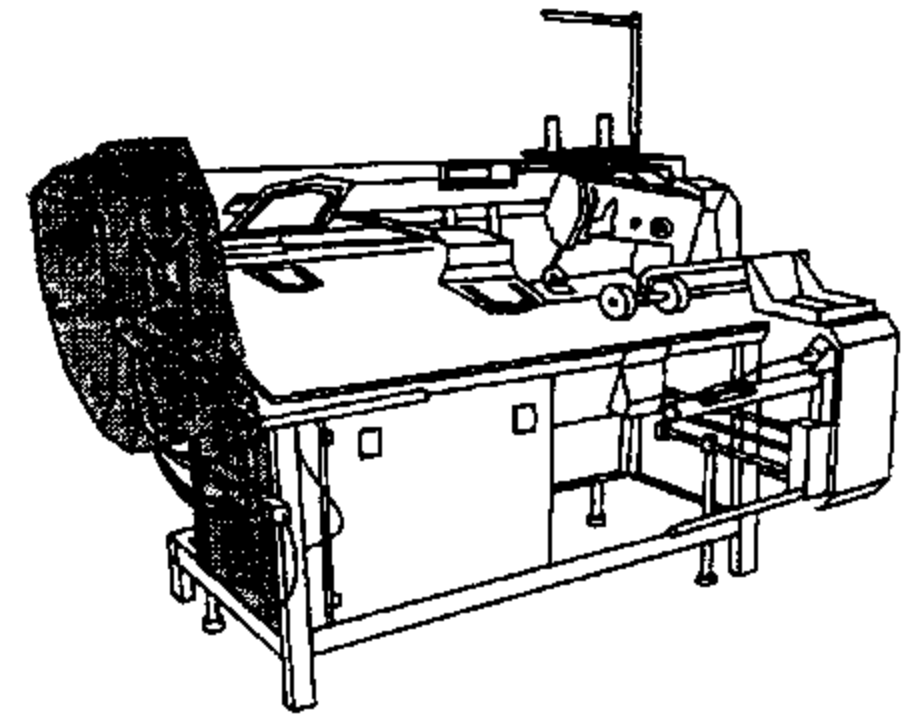

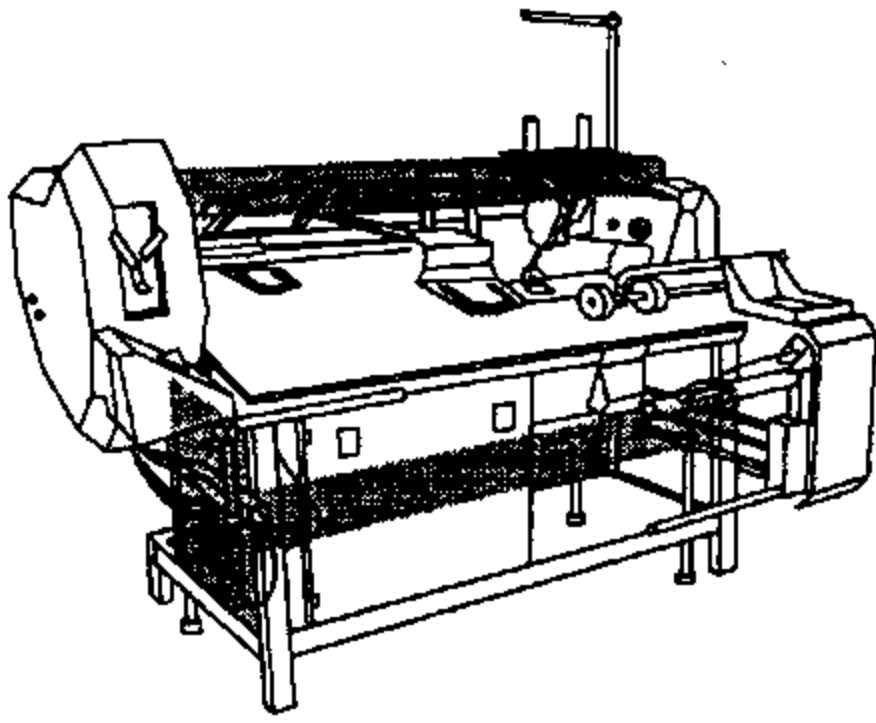

Verkleidung
Cover panel
Carters
Revestimiento PFAFF 3588-04/020

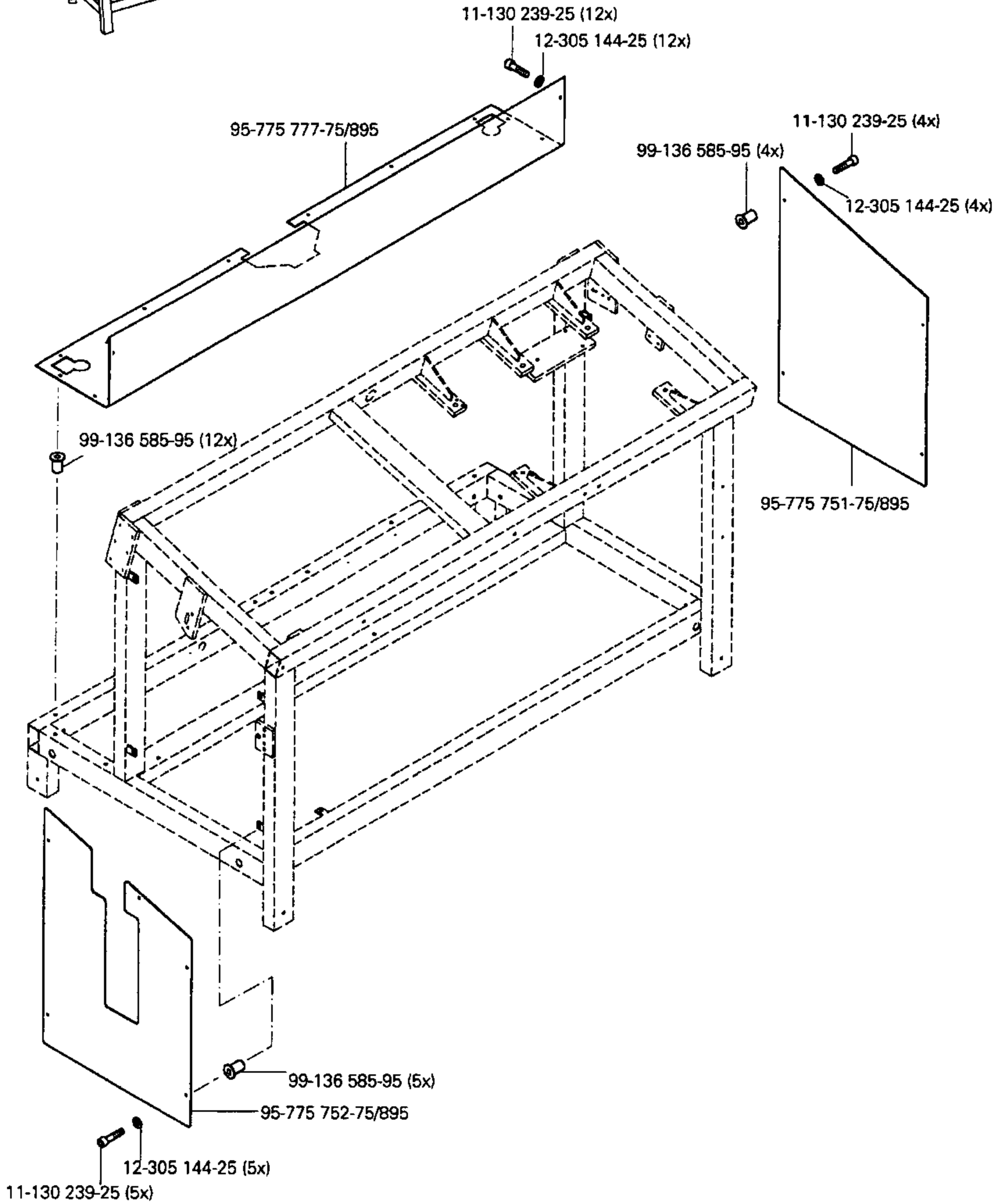

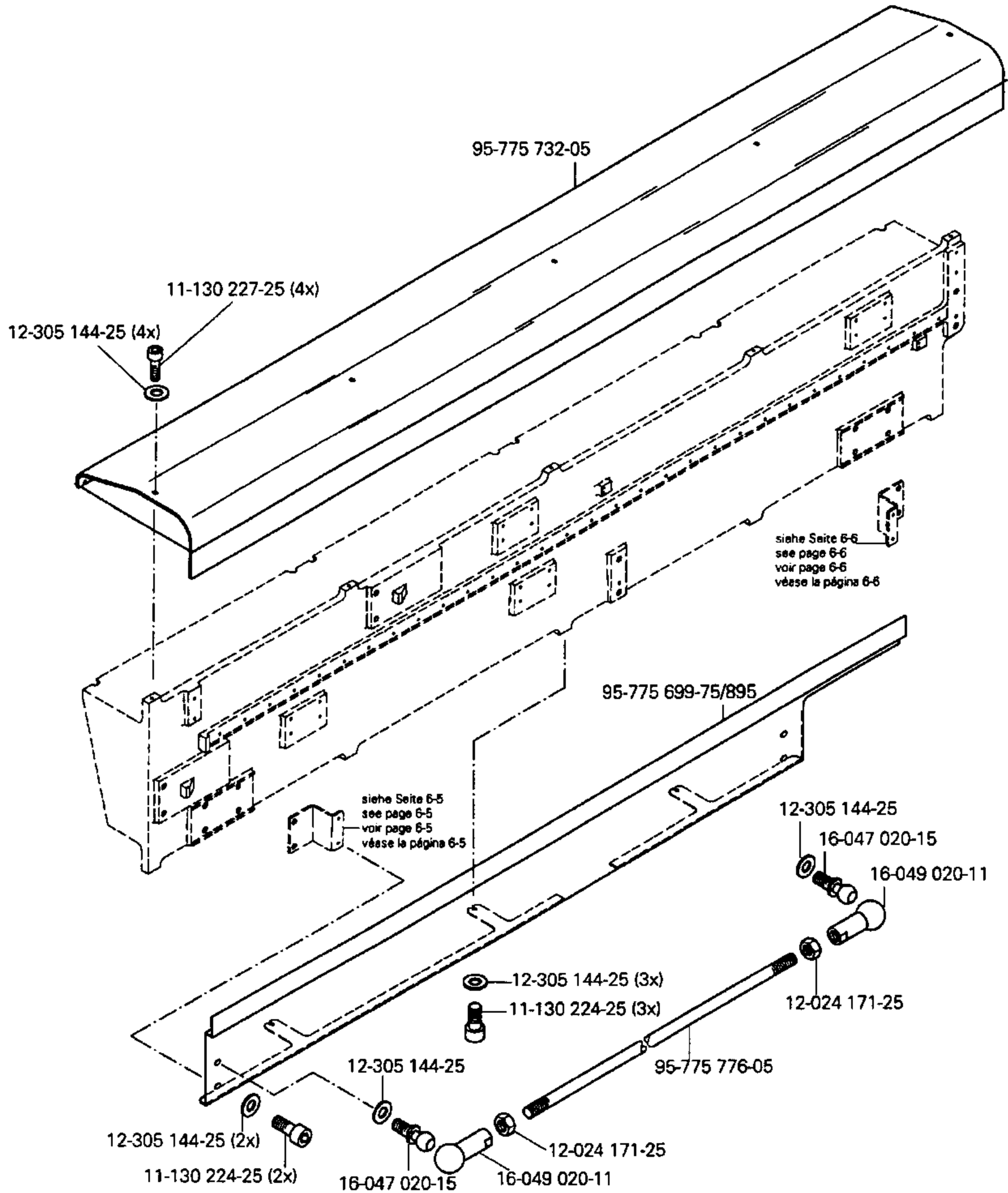
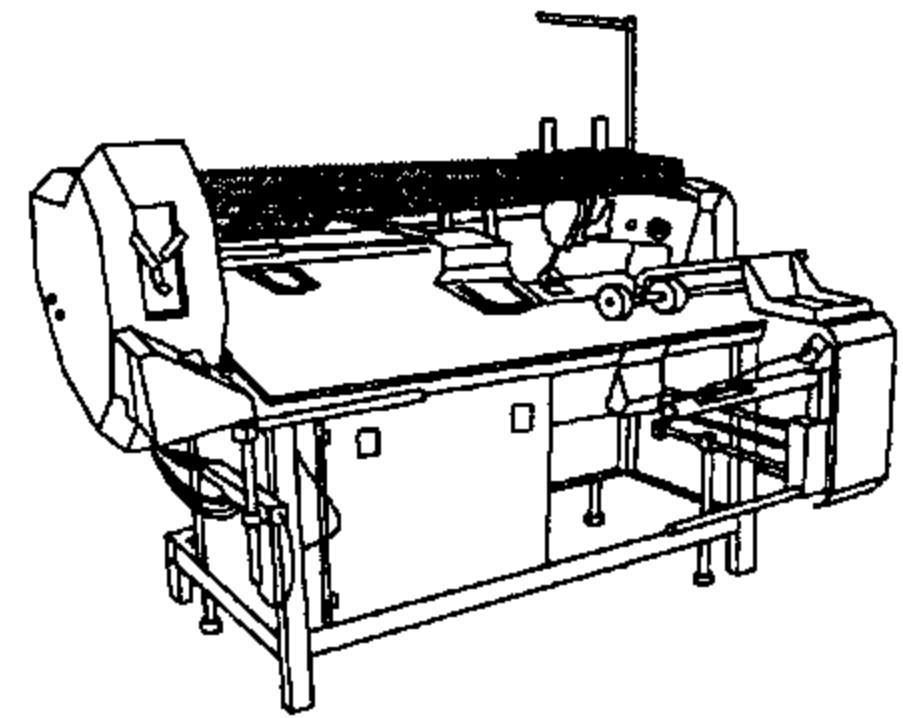

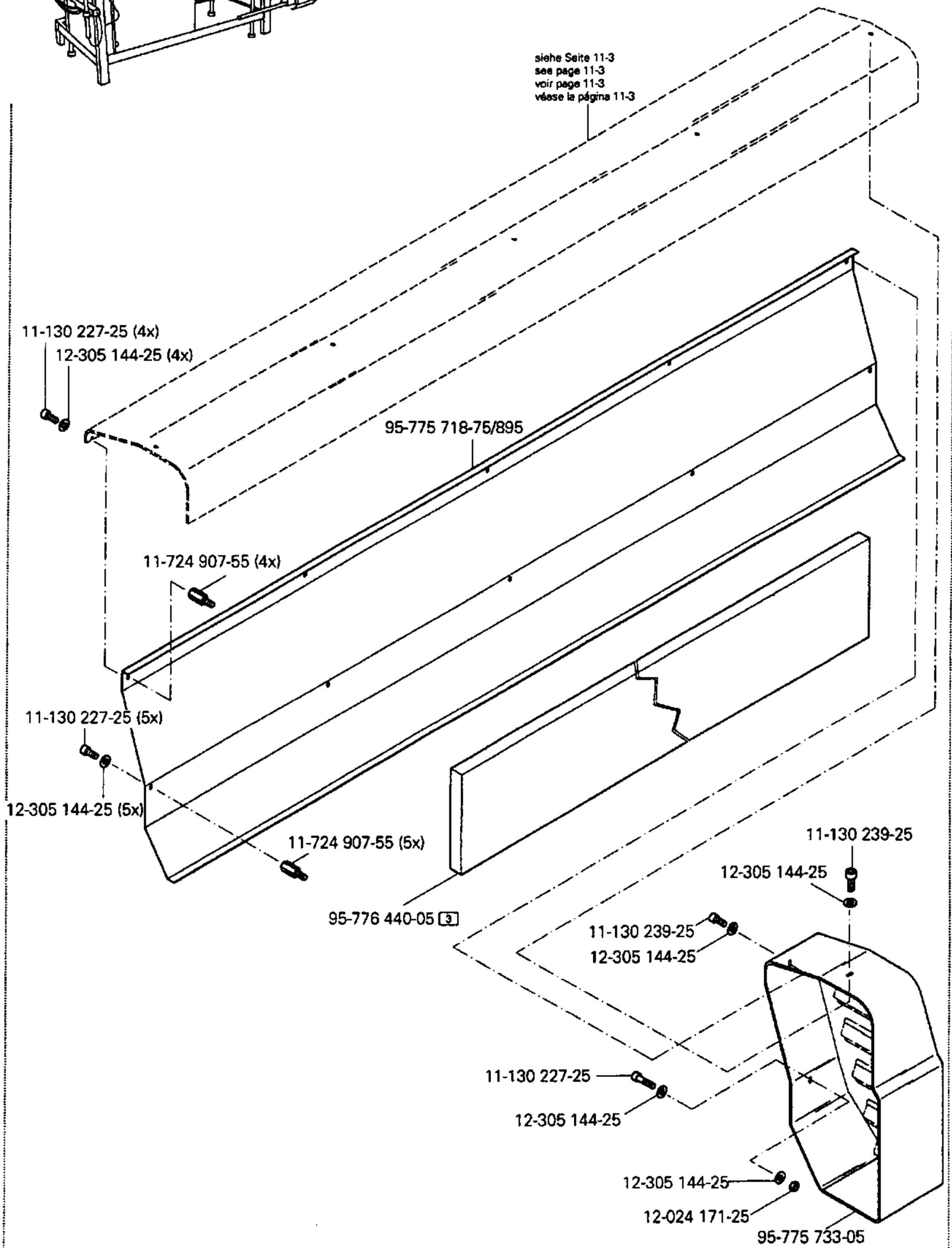
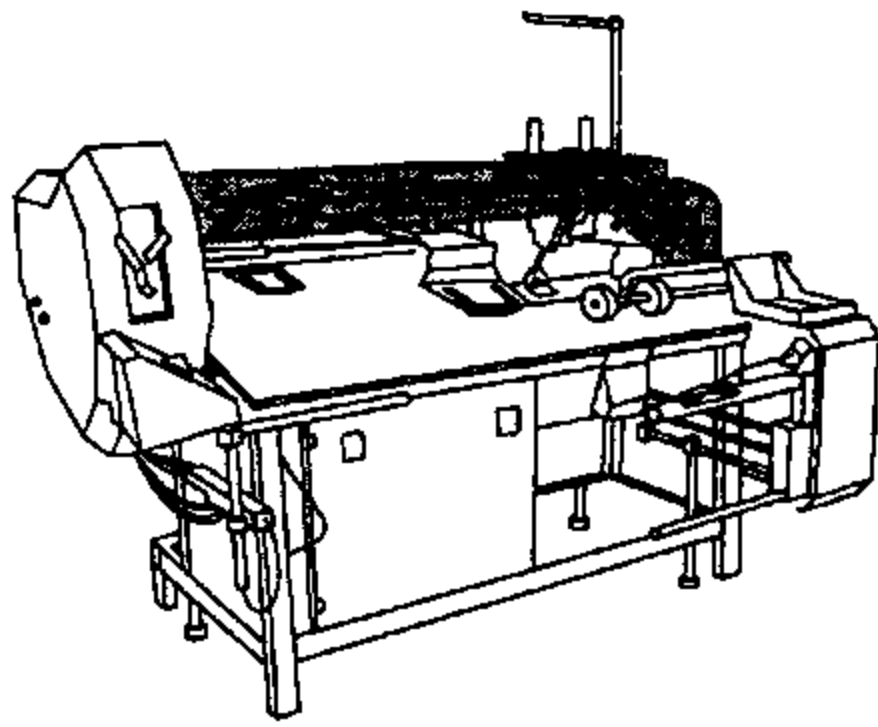

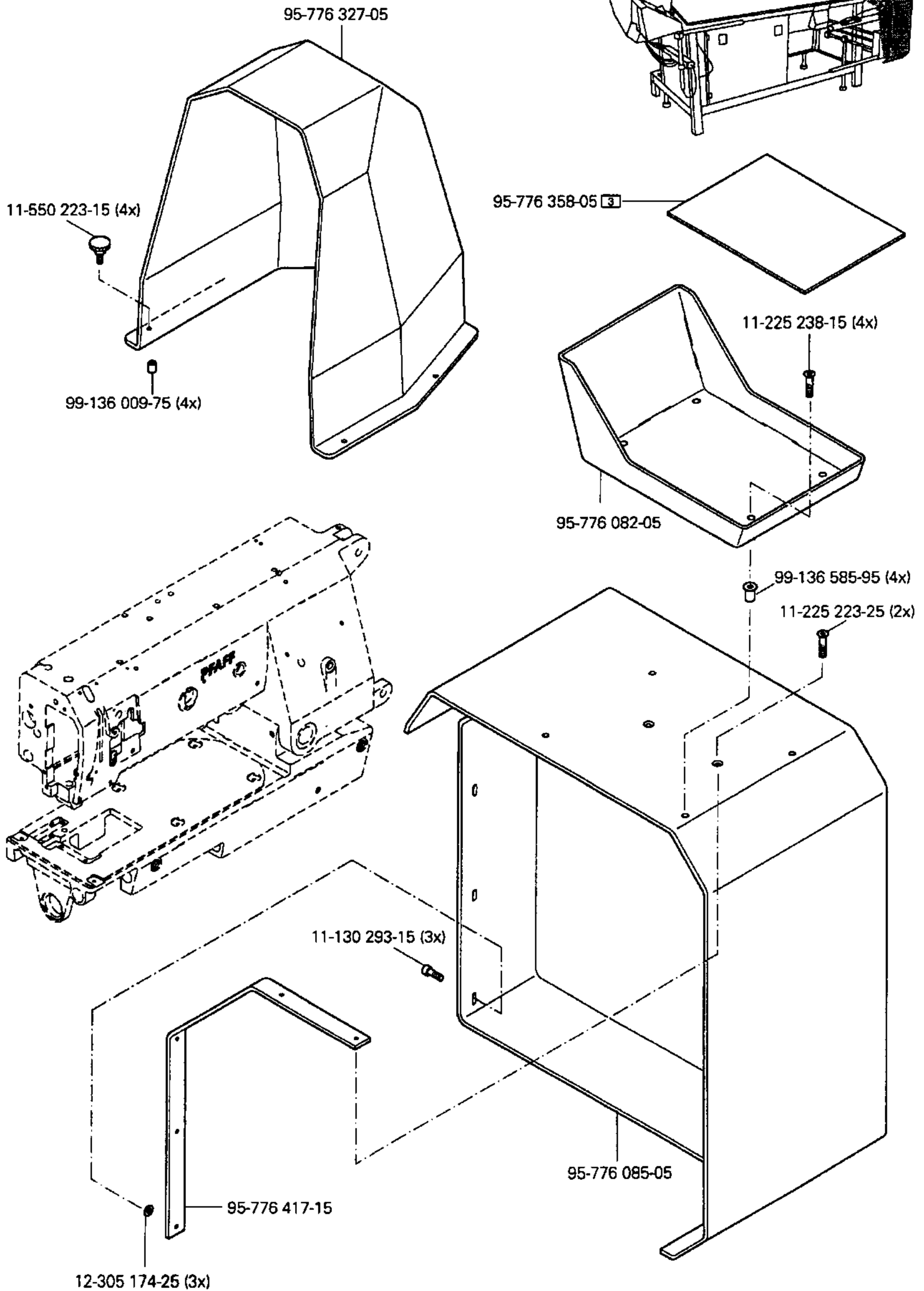
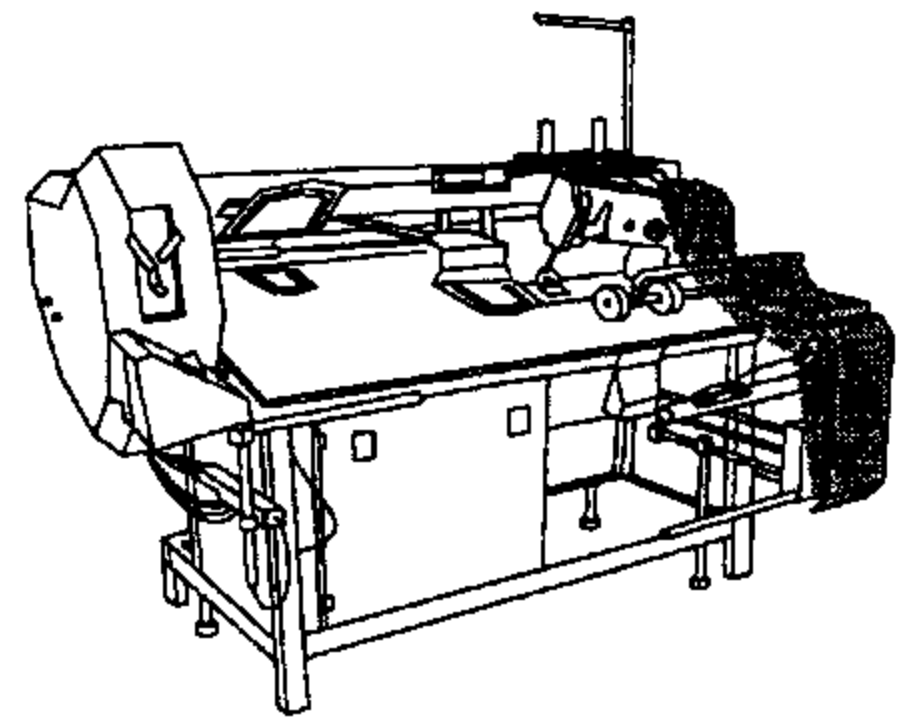

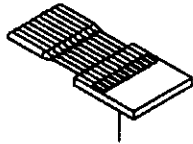
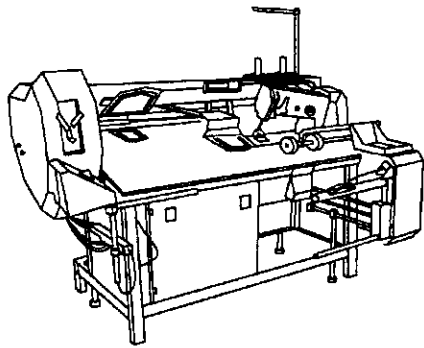





System 1955 
 Système 1955 
 Sistema 1955 

91-018 480-05



95-776 207-91 

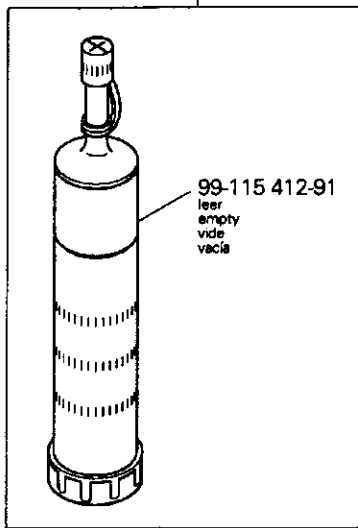

99-115 412-91
 leer
 empty
 vide
 vacia

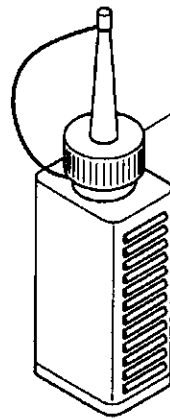

99-137 195-01
 leer
 empty
 vide
 vacia

91-027 631-91

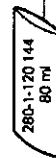

91-129 153-91

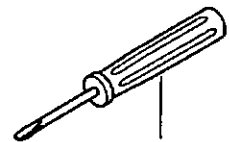
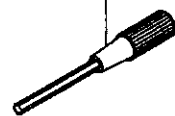

91-029 946-91

40-754 701-00

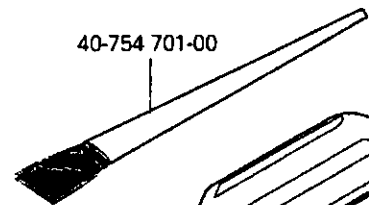

91-029 007-91

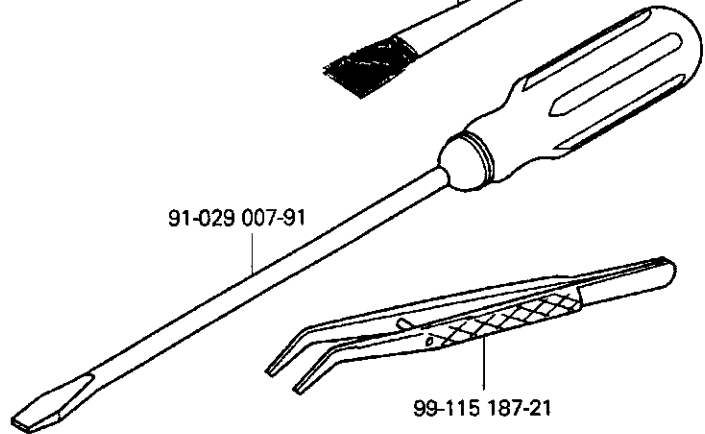

99-115 187-21

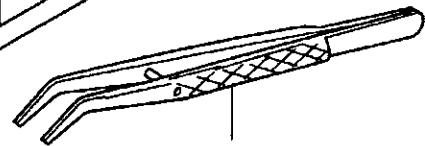

12.02

Garnrollenständer
 Reel stands
 Porte-bobines
 Portacarretes

PFAFF 3588-04/020

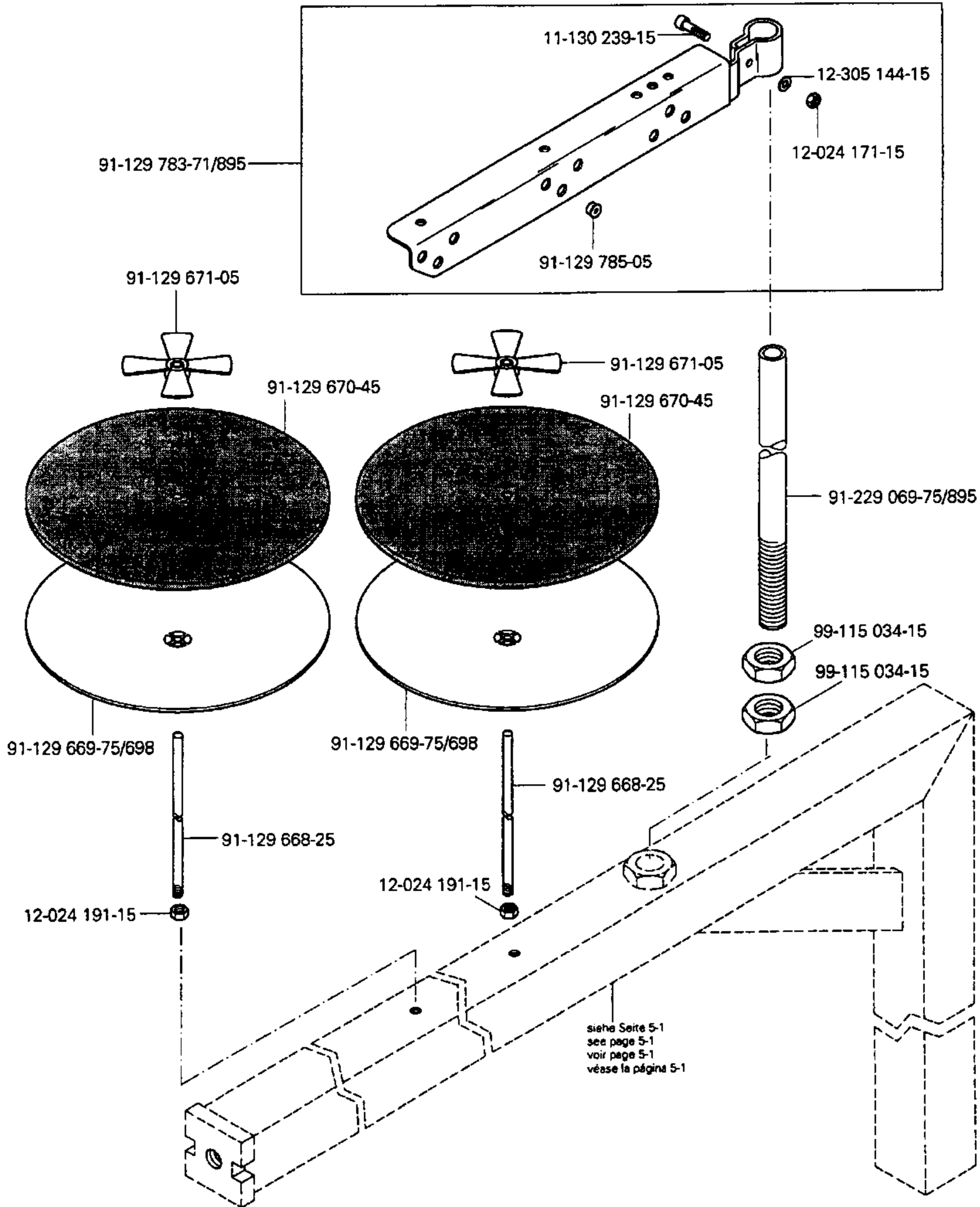
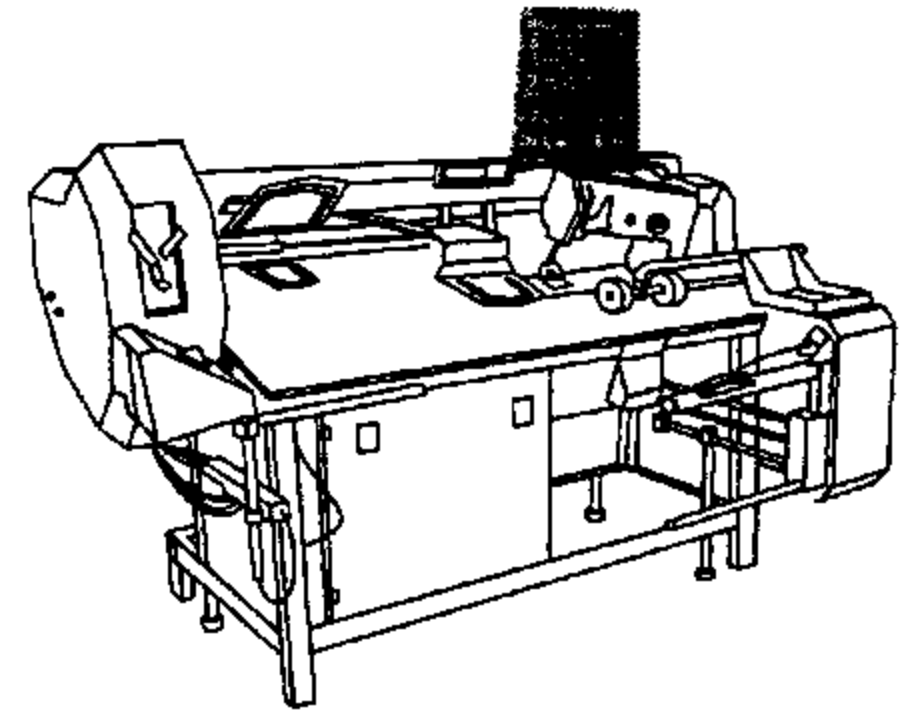

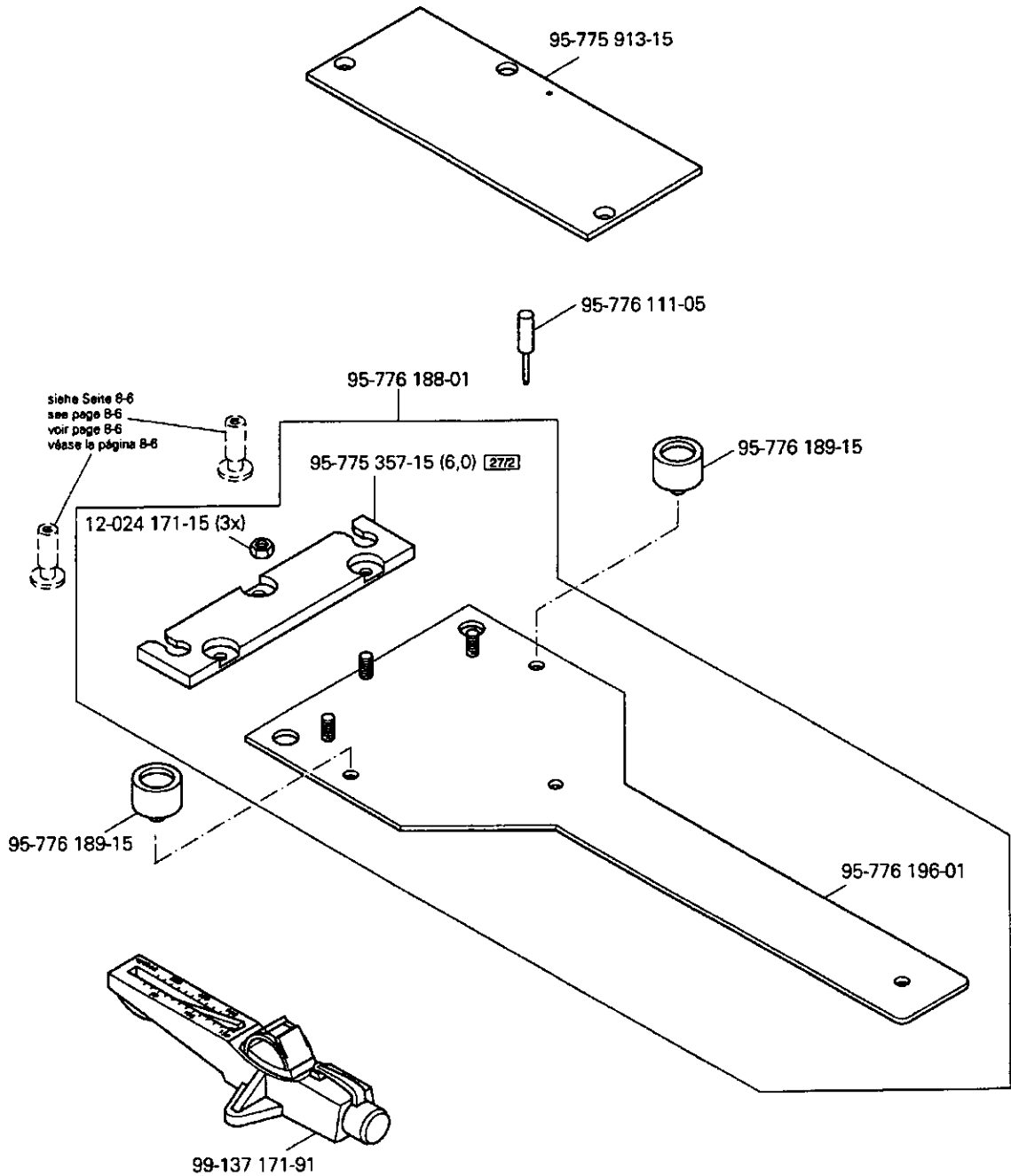
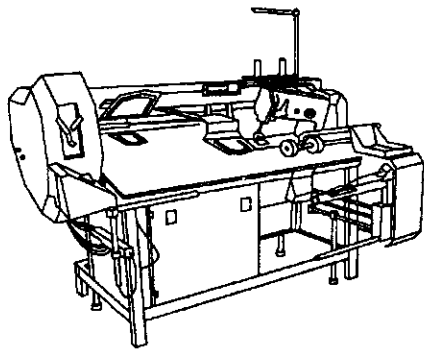

Öl Oil Huile Aceite	Mittelpunkts-Viskosität bei: Mean viscosity at: Viscosité moyenne à: Viscosidad media a:		Dichte bei: Density of: Densité à: Densidad a:		Bestellnummer für Behälter mit: Part number for can with: Numéro de commande pour récipients avec: Número de pedido para recipientes con:		
	°C	mm ² /s	°C	g/cm ³ (g/ml)	1 Liter 1 Litre 1 Litro	5 Liter 5 Litre 5 Litros	10 Liter 10 Litre 10 Litros
28-011 20 1-44	40	22,0	15	0,865	91-129 917-91	91-129 919-91	91-129 920-91

Fett Grease Graisse Grasa	Penetration Penetration Pénétration Penetración	Tropfpunkt Drip-point Point de suintement Punto de goteo	Bestellnummer für Behälter mit: Part number for can with: Numéro de commande pour récipients avec: Número de pedido para recipientes con:				
			mm/10	°C	0,25 kg	0,5 kg	1 kg
28-011 202-05							28-011 202-05
28-011 202-10		185					28-011 202-10
28-011 202-43	375-405	150			28-011 202-43		
28-011 202-47	220-250	185					28-011 202-47

Reinigungsmittel Cleansing agent Agents de nettoyage Limpiadores	Bestellnummer für Behälter mit: Part number for can with: Numéro de commande pour récipients avec: Número de pedido para recipientes con:
Isoprophyl-Alkohol	95-665 735-91

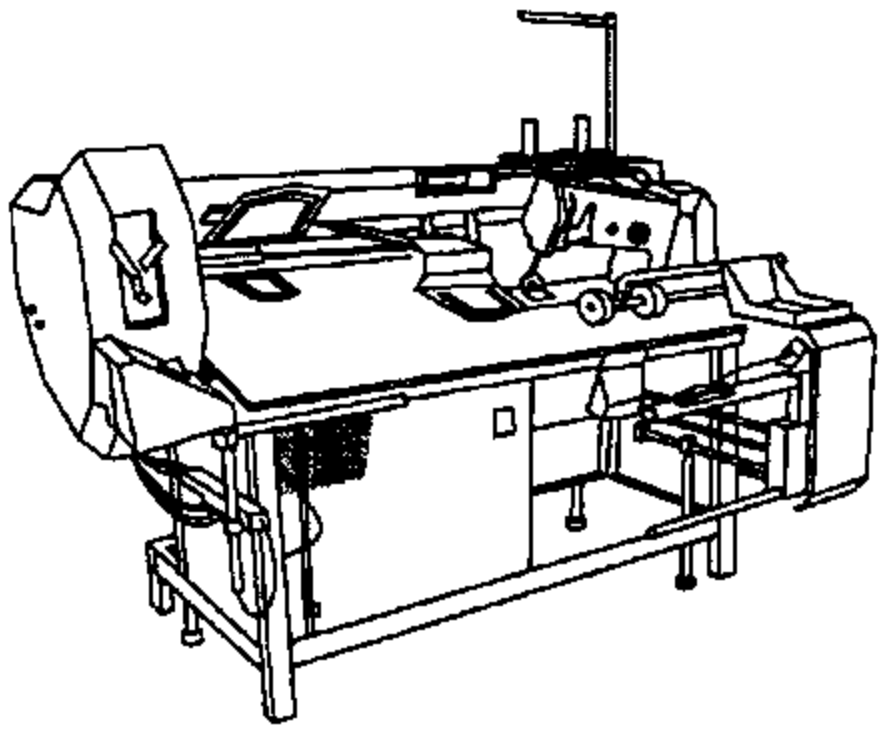

Diskettenlaufwerk mit Leitung
 Disc drive with cable
 Lecteur de disquettes avec câble
 Lector de discos con cable

PFAFF 3588-04/020

15.01

91-094 639-73/002

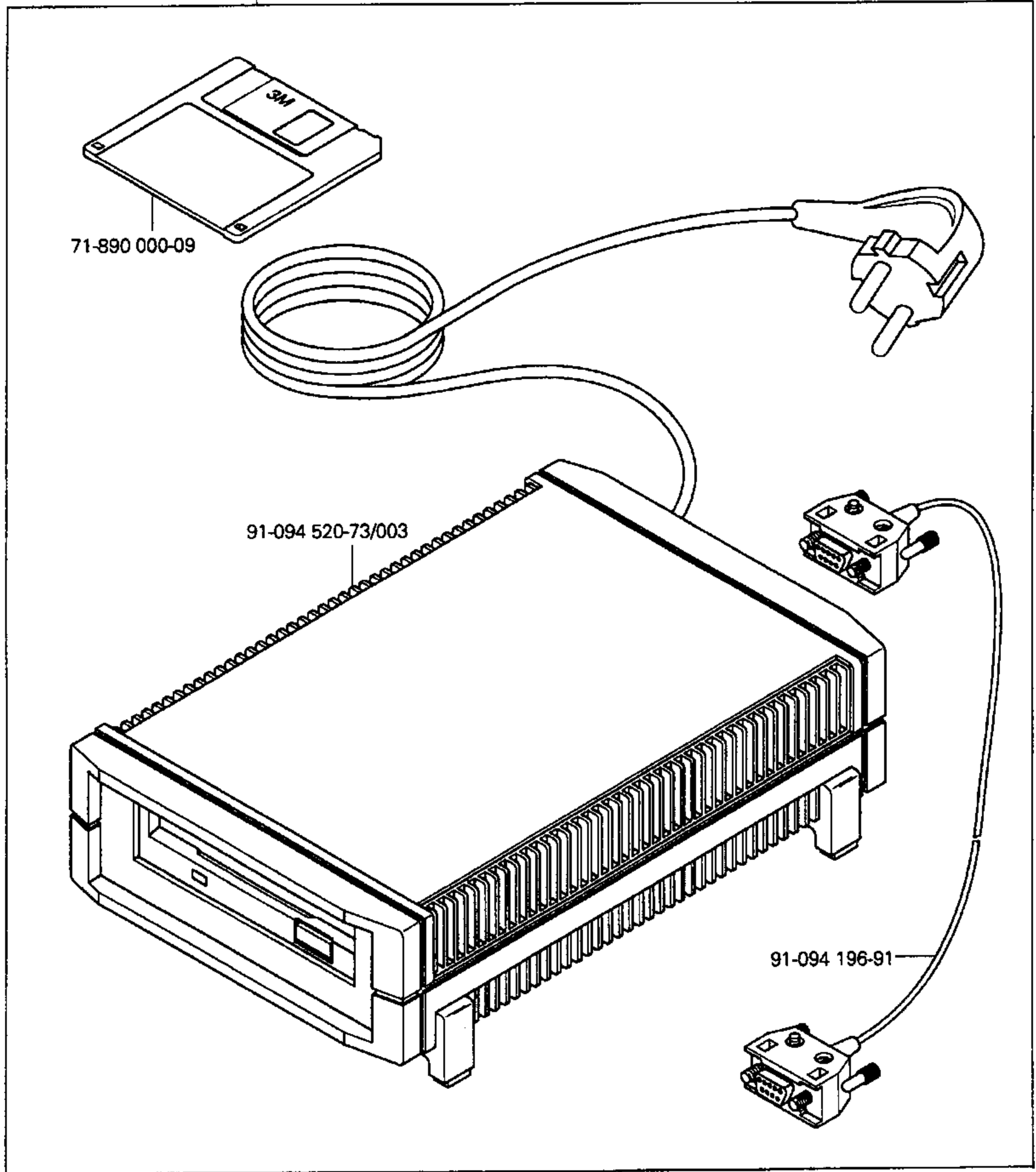

PFAFF

siehe Kapitel 2 Erläuterung der Schlüsselzeichen
 see chapter 2 Explanation of key markings
 voir le chap. 2 Explication des symboles
 véase el Cap. 2 Explicaciones de los signos clave

15.02

Höhenverstellung für Gestell PFAFF 3588-04/020
 Vertical adjustment for frame
 Réglage de la hauteur du bâti
 Regulación de la altura del bastidor

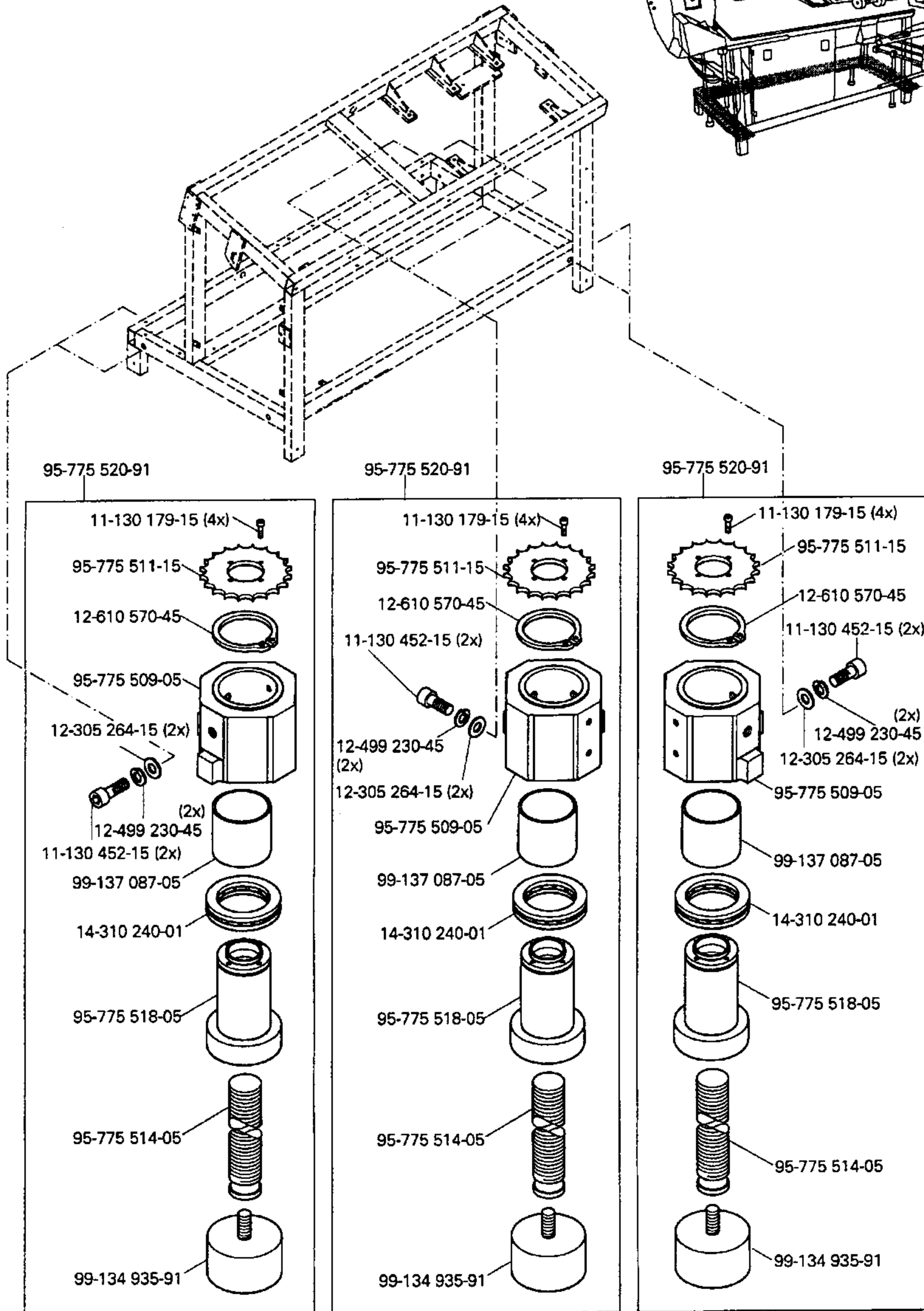
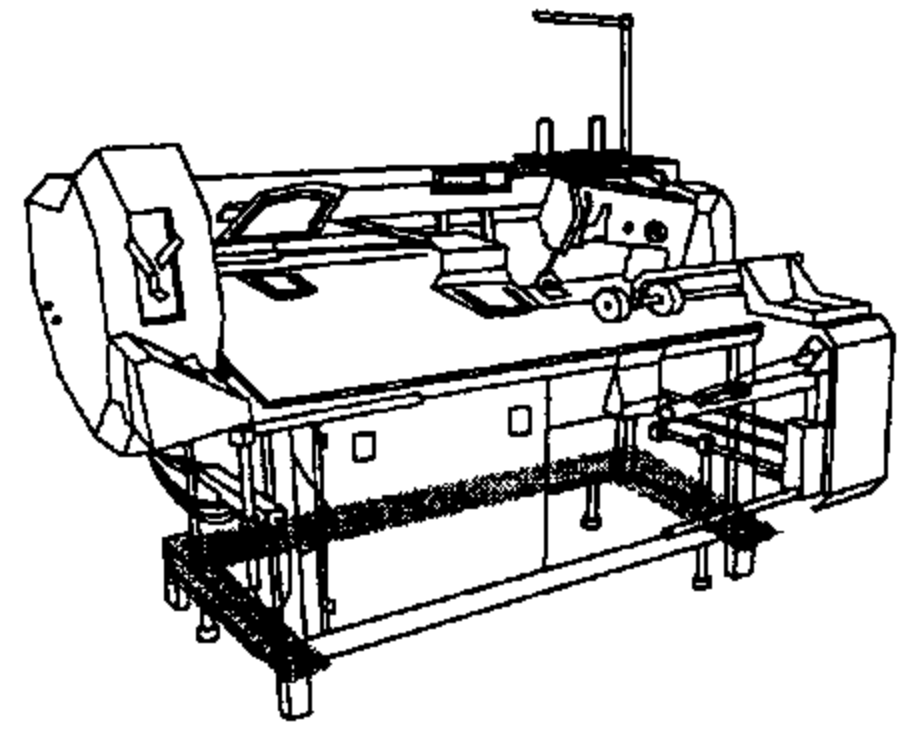

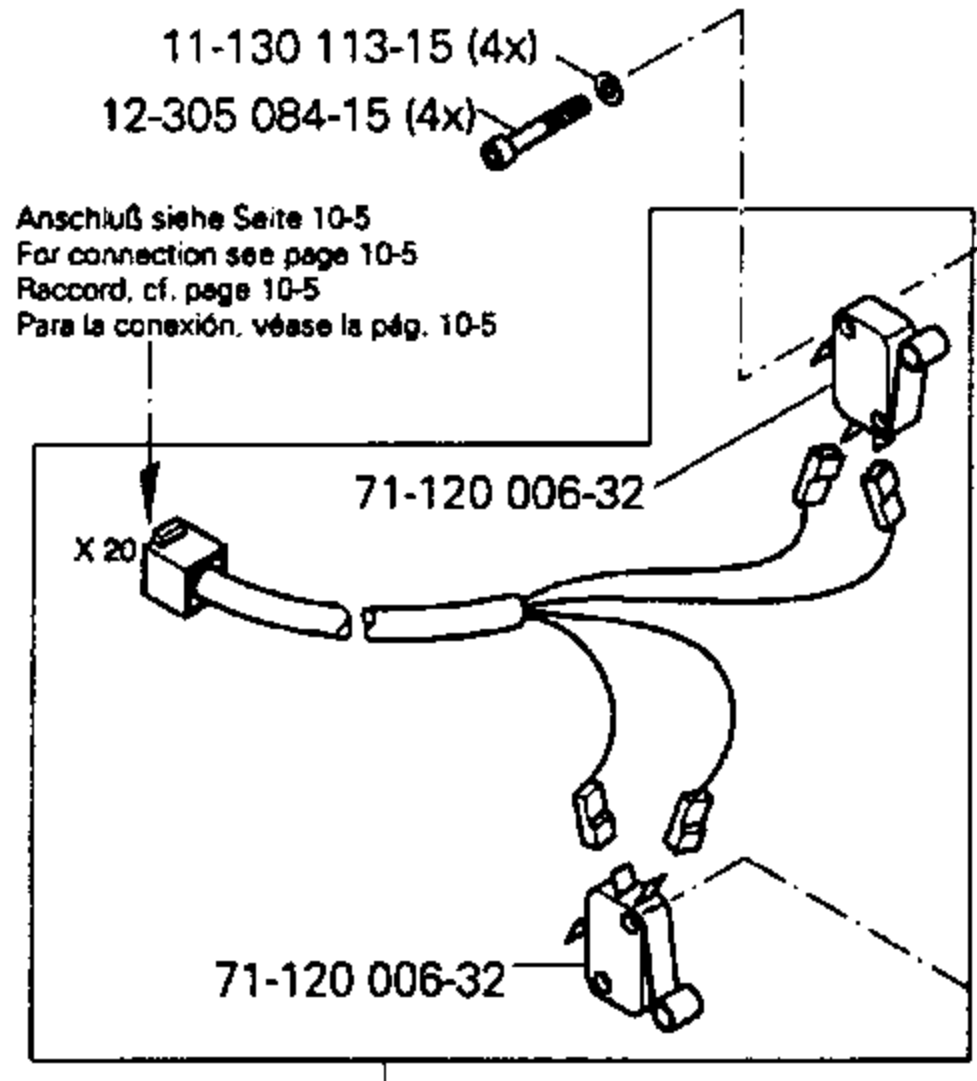
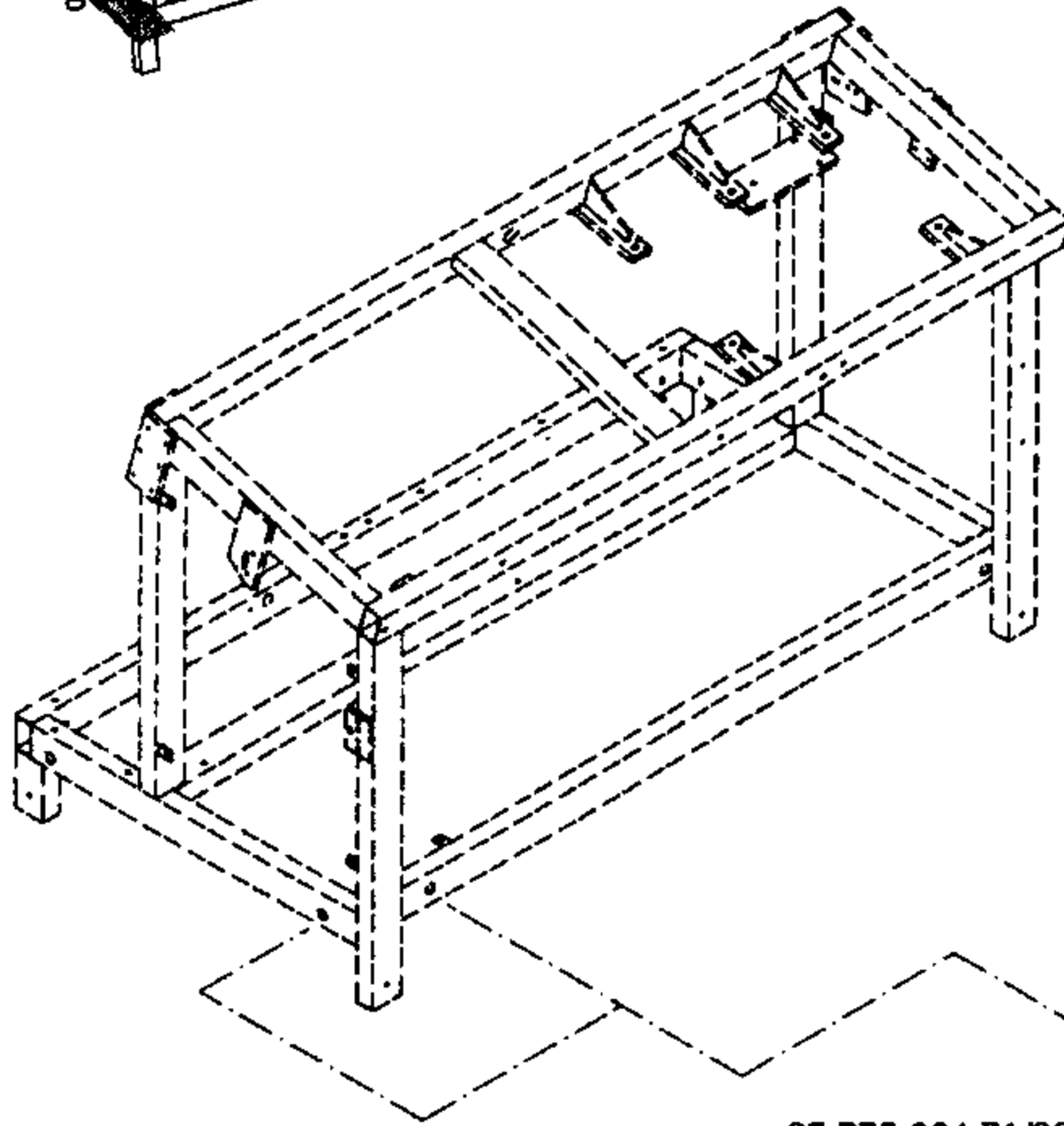
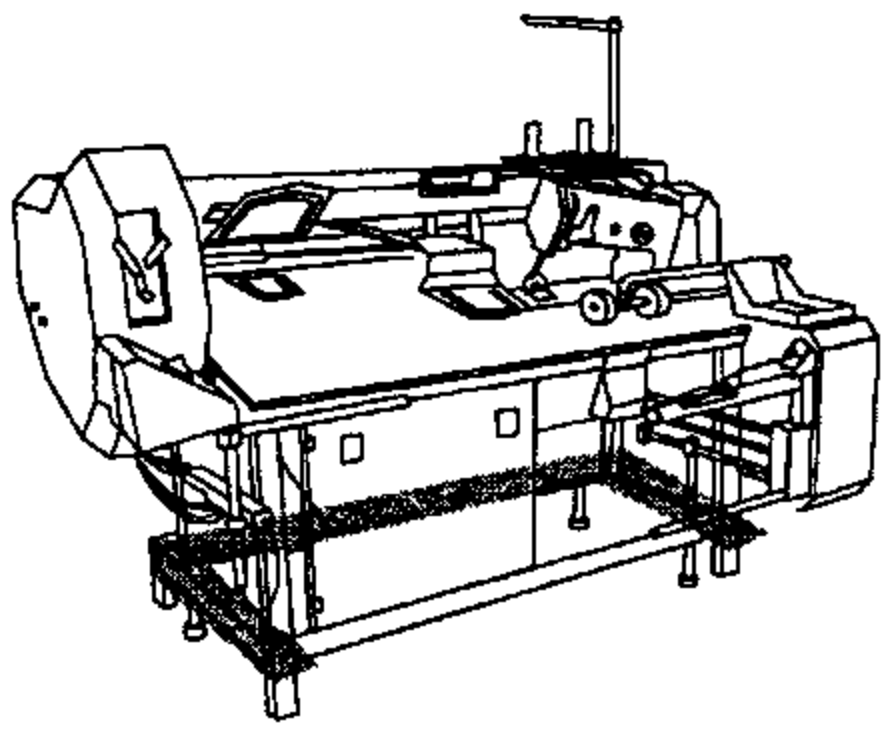

95-775 664-71/893

91-291 582-91

11-130 293-15 (2x)

95-775 665-75/893

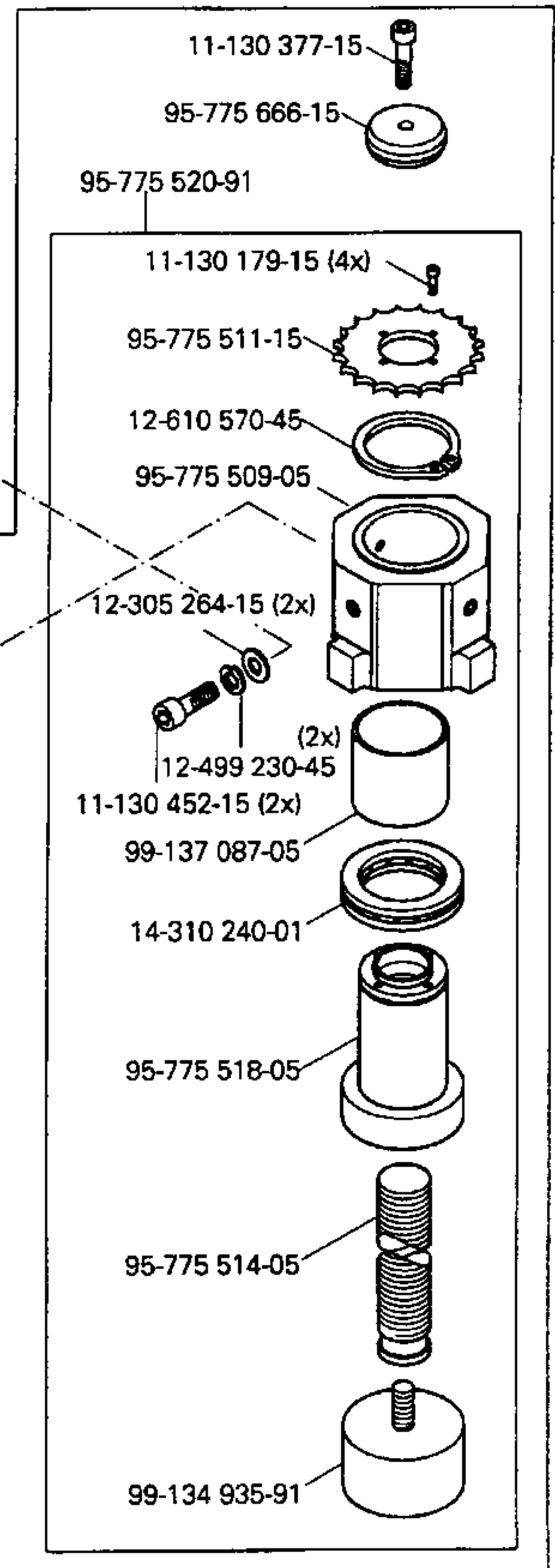

15.02

Höhenverstellung für Gestell PFAFF 3588-04/020
 Vertical adjustment for frame
 Réglage de la hauteur du bâti
 Regulación de la altura del bastidor

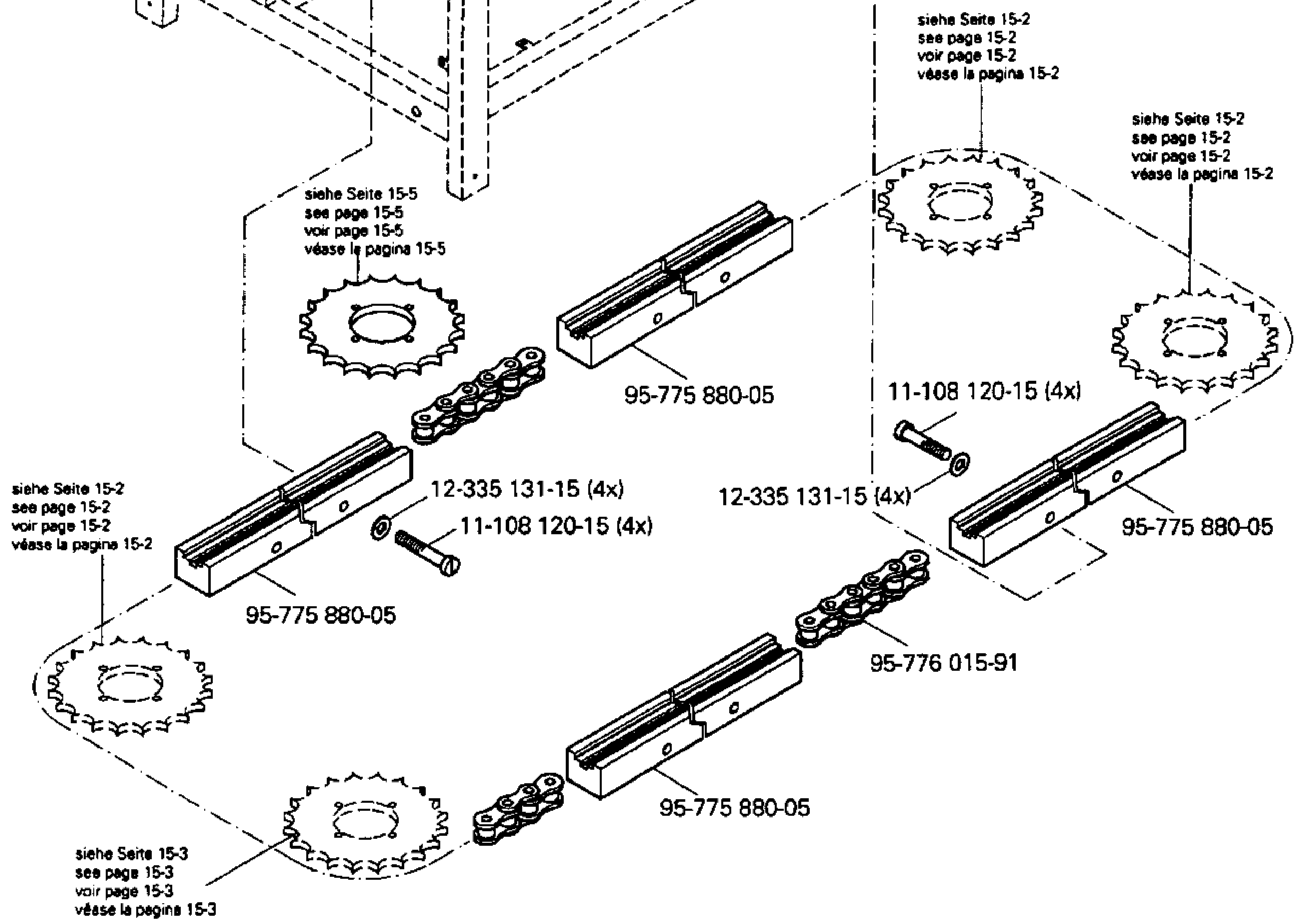
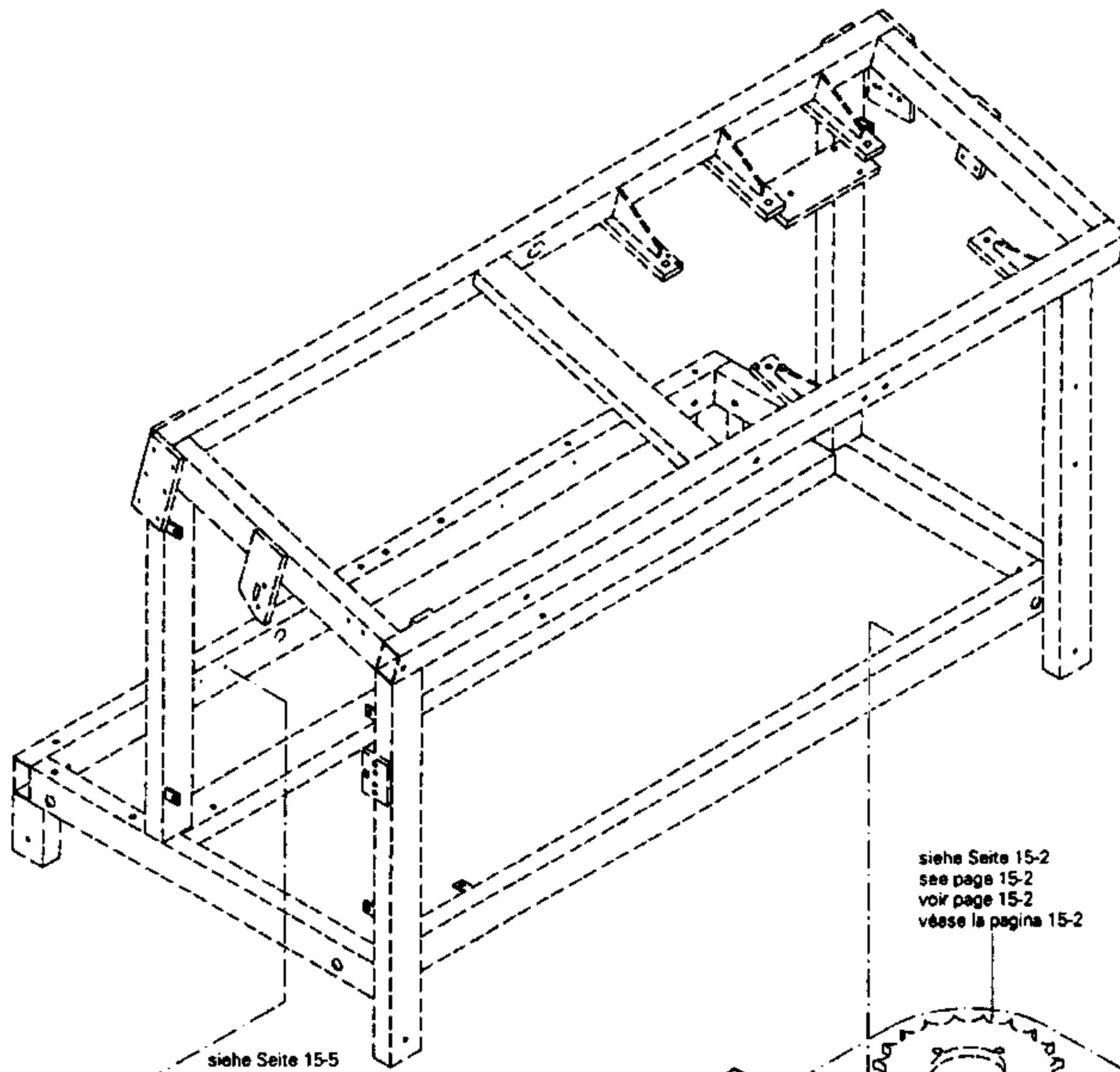
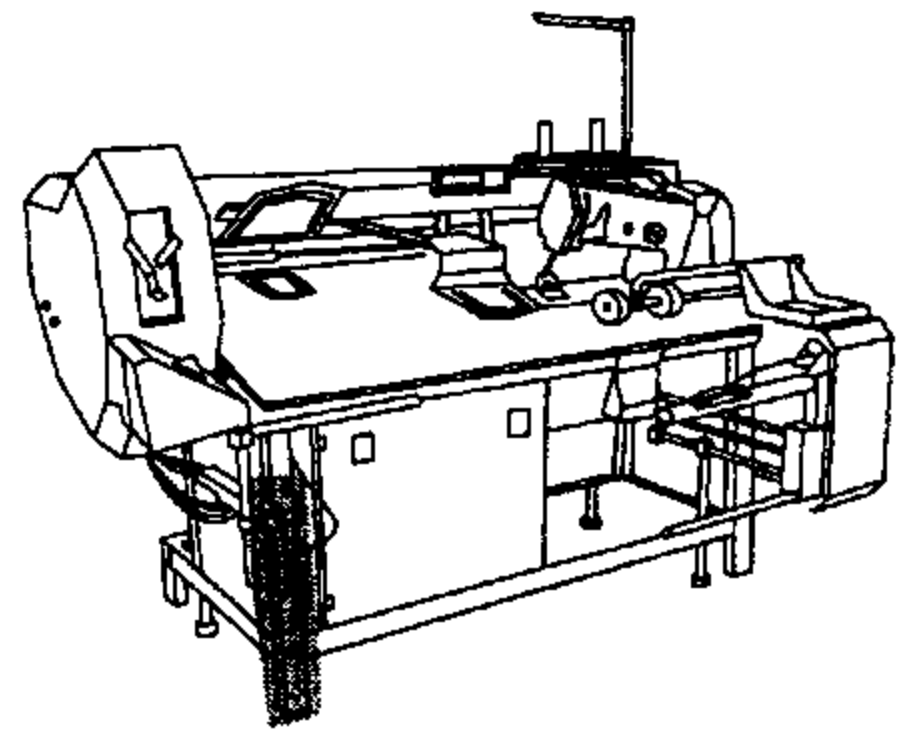

Höhenverstellung für Gestell
 Vertical adjustment for frame
 Réglage de la hauteur du bâti
 Regulación de la altura del bastidor

PFAFF 3588-04/020

15.02

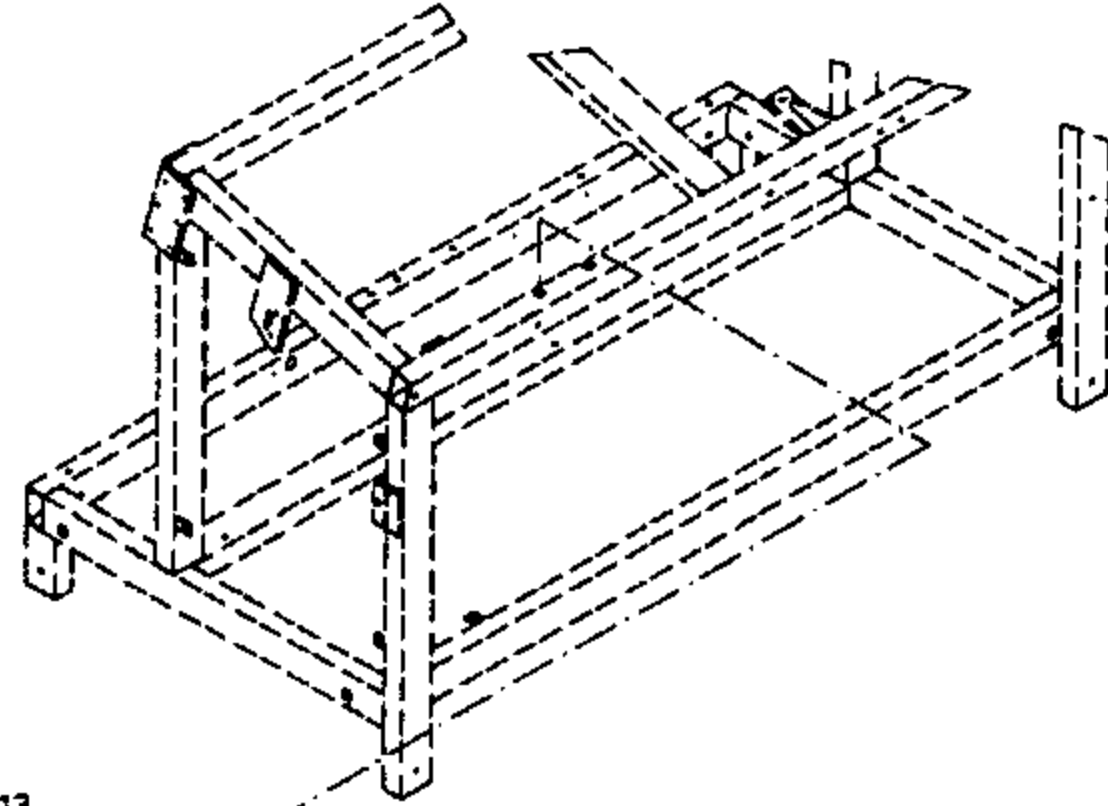
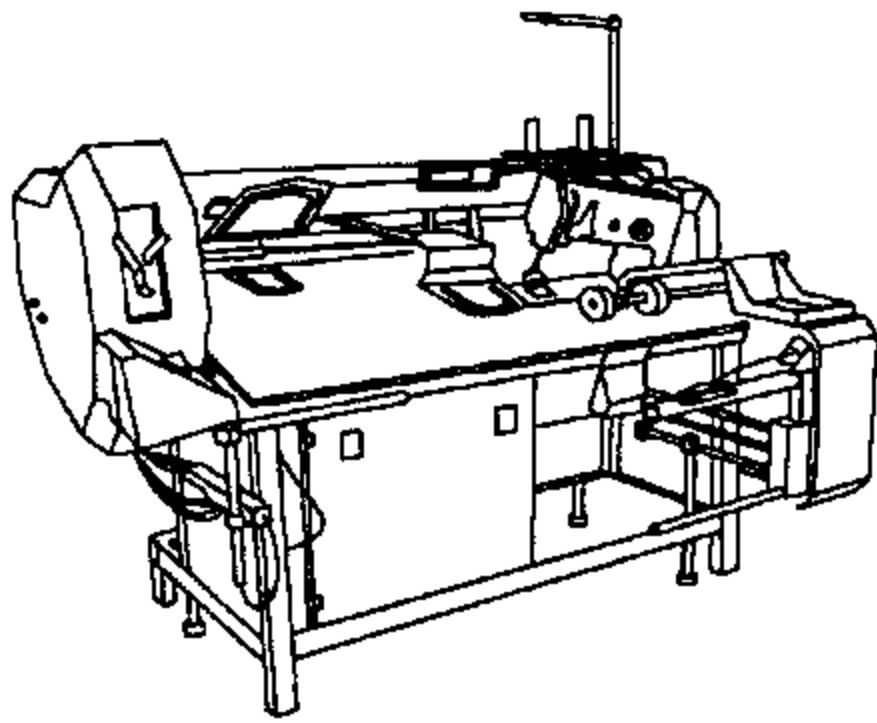

Anschluß siehe Seite 10-13
 For connection see page 10-13
 Raccord, cf. page 10-13
 Para la conexión, véase la pág. 10-13

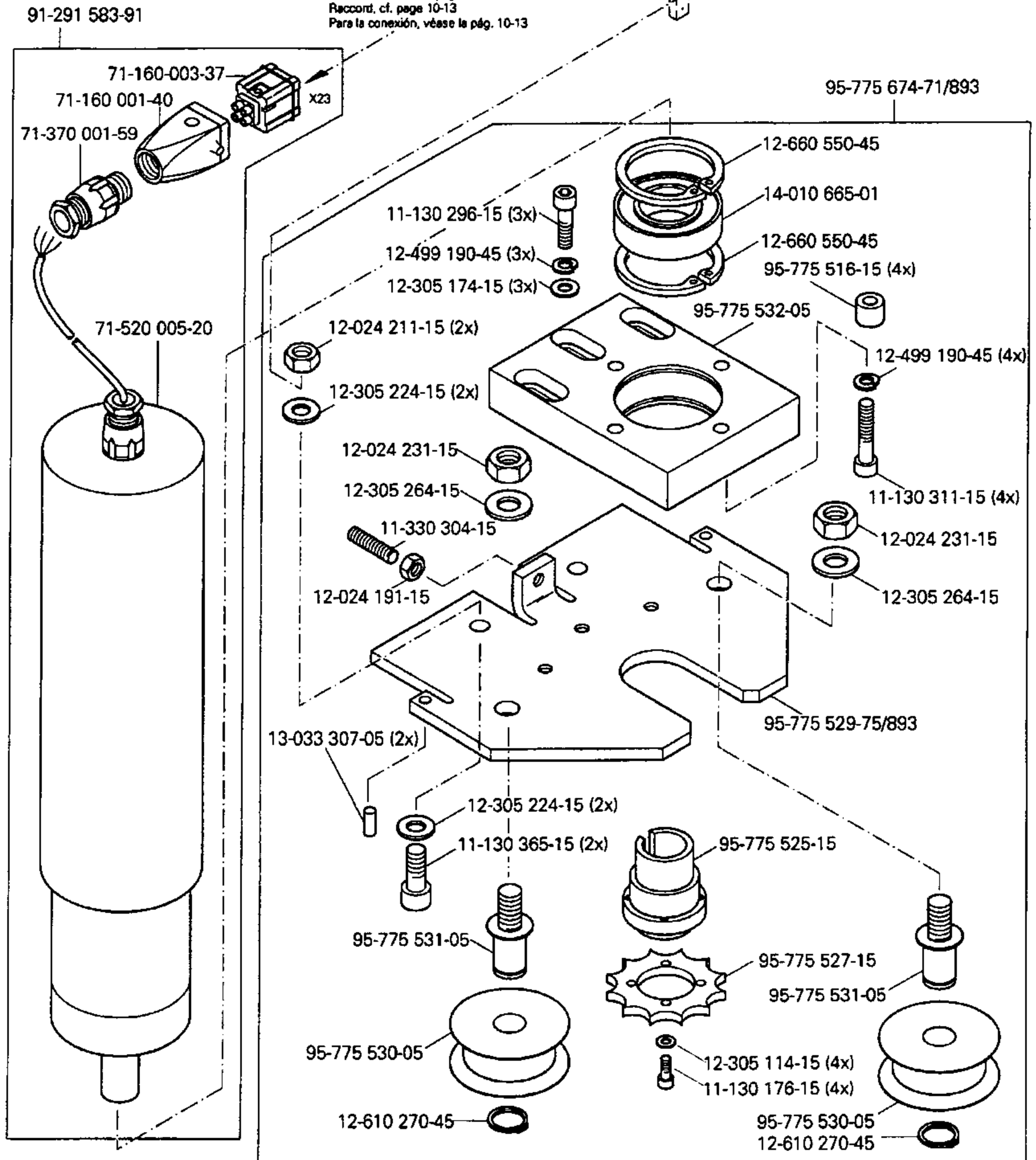

PFAFF

☐ siehe Kapitel 2 Erläuterung der Schlüsselzeichen
 see chapter 2 Explanation of key markings
 voir le chap. 2 Explication des symboles
 véase el Cap. 2 Explicaciones de los signos clave

15.02

Höhenverstellung für Gestell PFAFF 3588-04/020
 Vertical adjustment for frame
 Réglage de la hauteur du bâti
 Regulación de la altura del bastidor

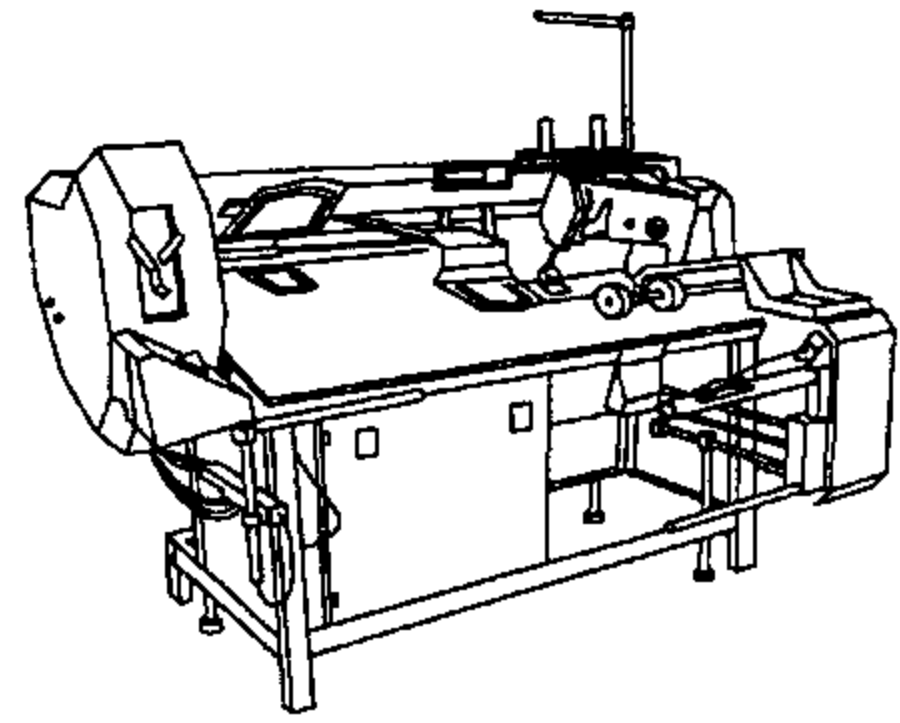

95-775 851-75/893

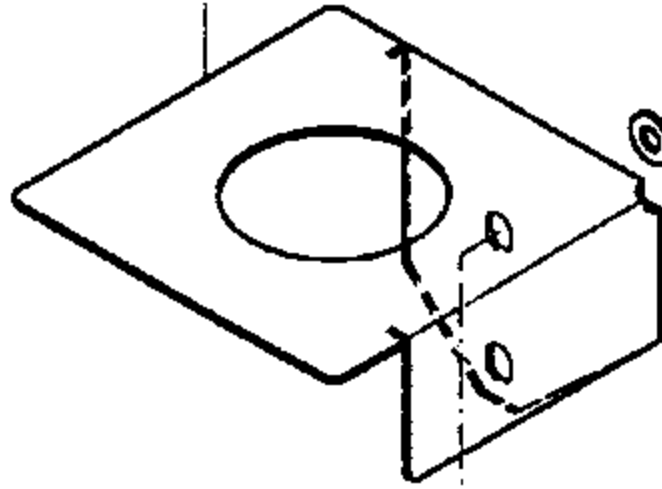

11-130 293-15 (2x)
 12-305 174-15 (2x)

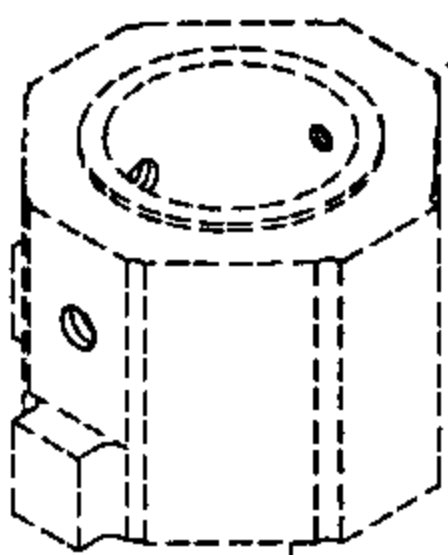

siehe Seite 15-2
 see page 15-2
 voir page 15-2
 véase la página 15-2

siehe Seite 15-2
 see page 15-2
 voir page 15-2
 véase la página 15-2

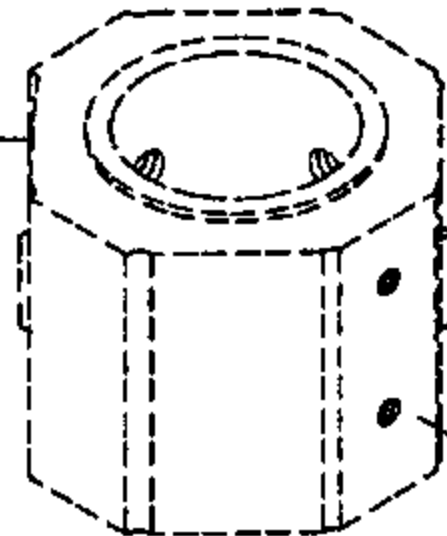

95-775 851-75/893

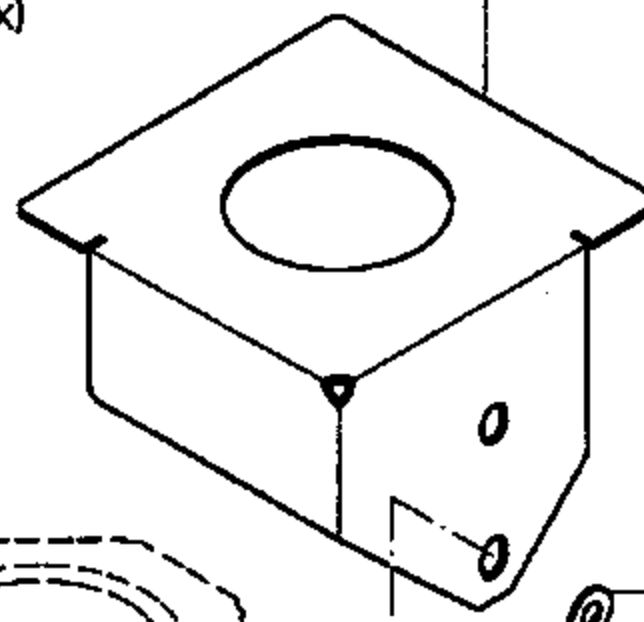

12-305 174-15 (2x)

11-130 293-15 (2x)

95-775 851-75/893

11-130 293-15 (2x)

12-305 174-15 (2x)

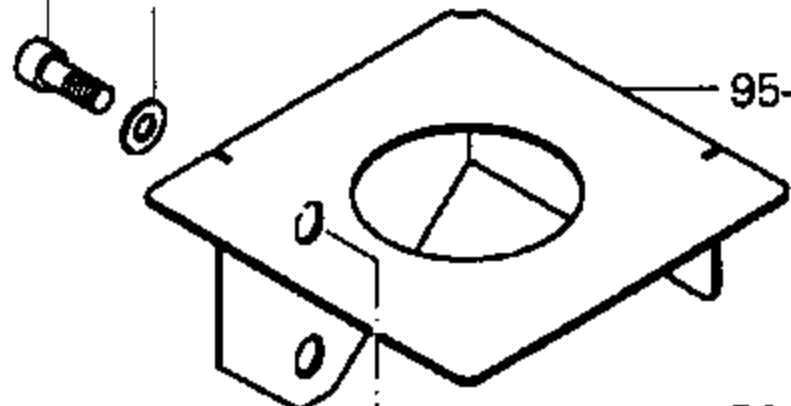

95-775 851-75/893

siehe Seite 15-3
 see page 15-3
 voir page 15-3
 véase la página 15-3

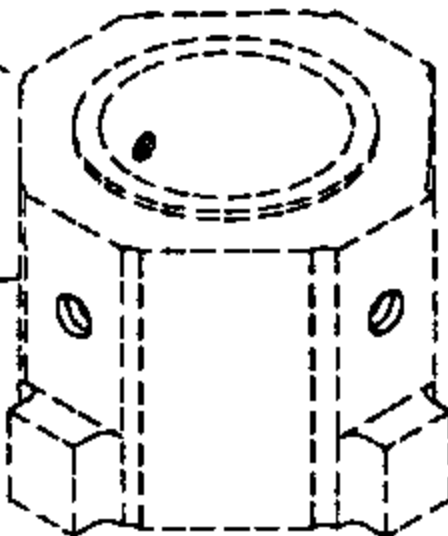

11-130 293-15 (2x)

12-305 174-15 (2x)

siehe Seite 15-2
 see page 15-2
 voir page 15-2
 véase la página 15-2

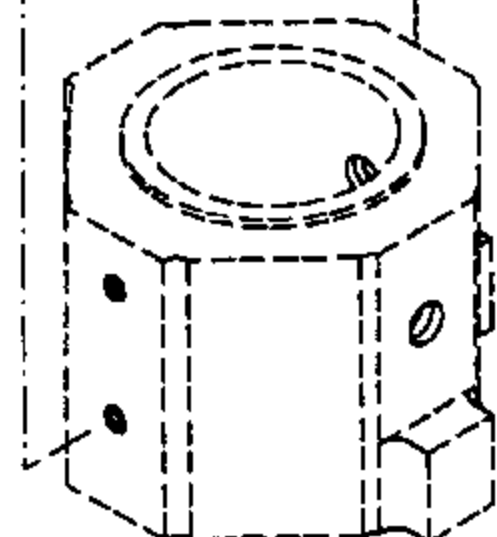
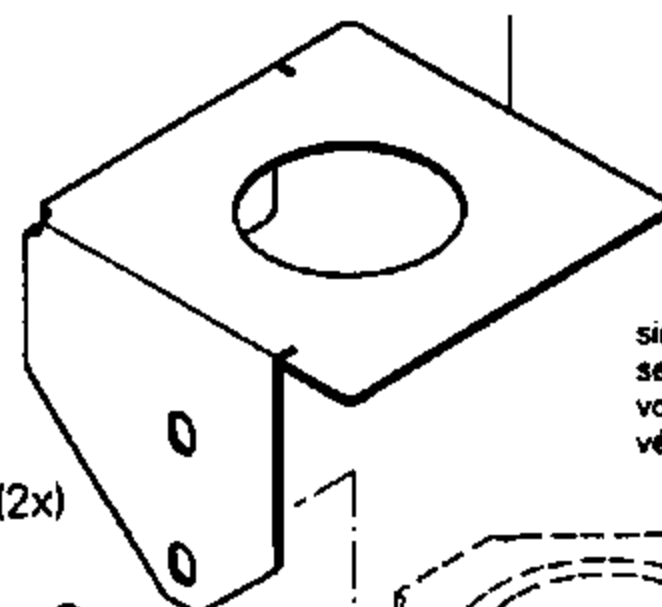

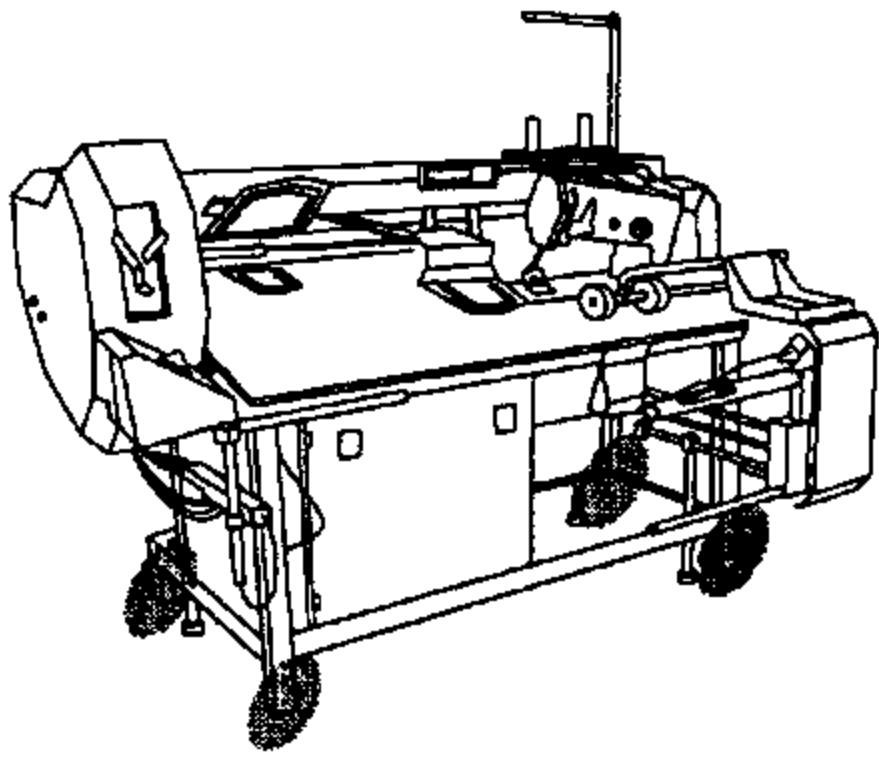

Transportrolle
 Feed roller
 Galet d'entraînement
 Rodillo el transporte PFAFF 3588-04/020

15.03

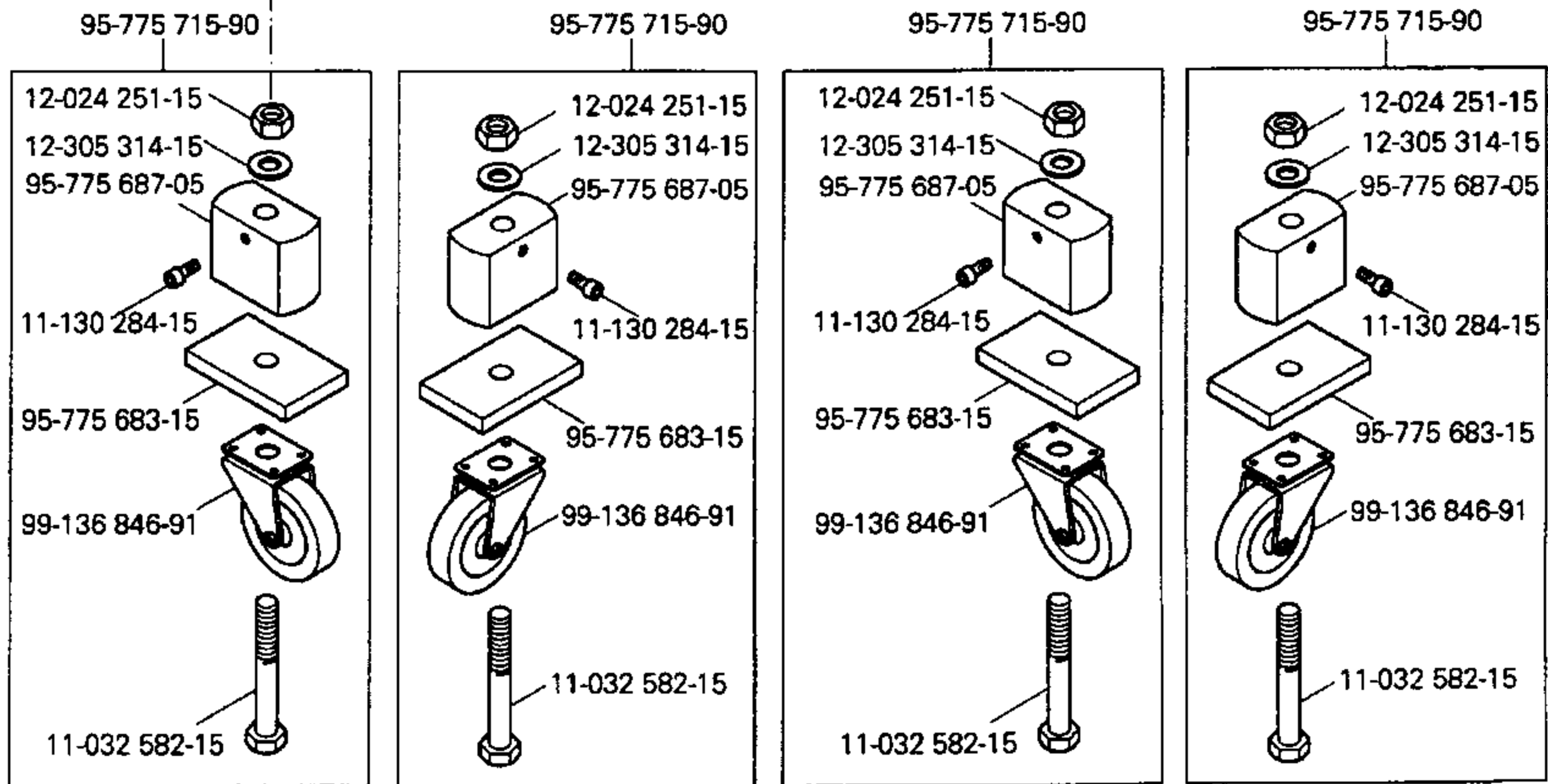
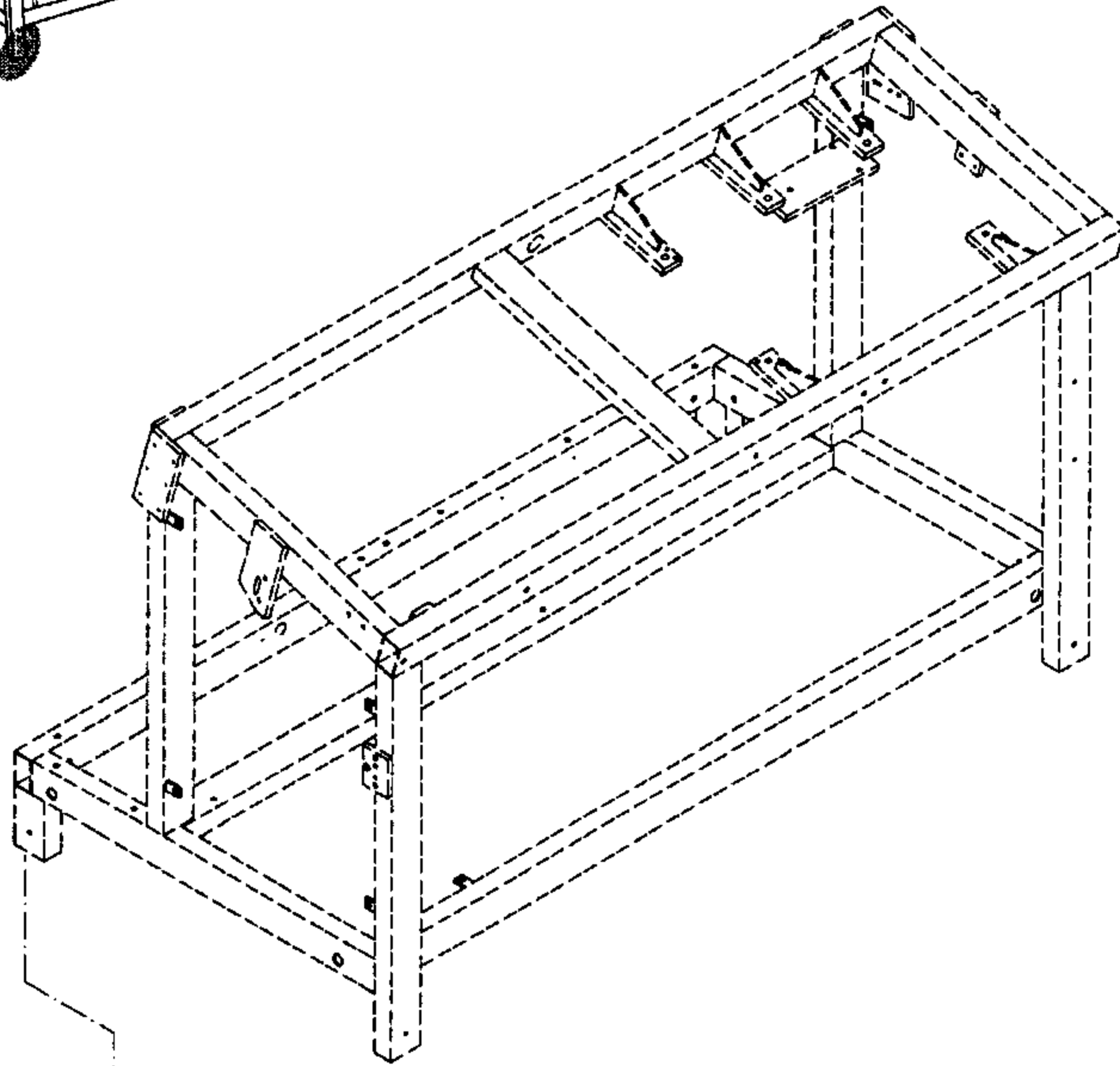

PFAFF



 siehe Kapitel 2 Erläuterung der Schlüsselzeichen
 see chapter 2 Explanation of key markings
 voir le chap. 2 Explication des symboles
 véase el Cap. 2 Explicaciones de los signos clave

15.04

Ecken-Umbuggschieber Edge folders Glissière rempliage du coin Remetedor de esquinas

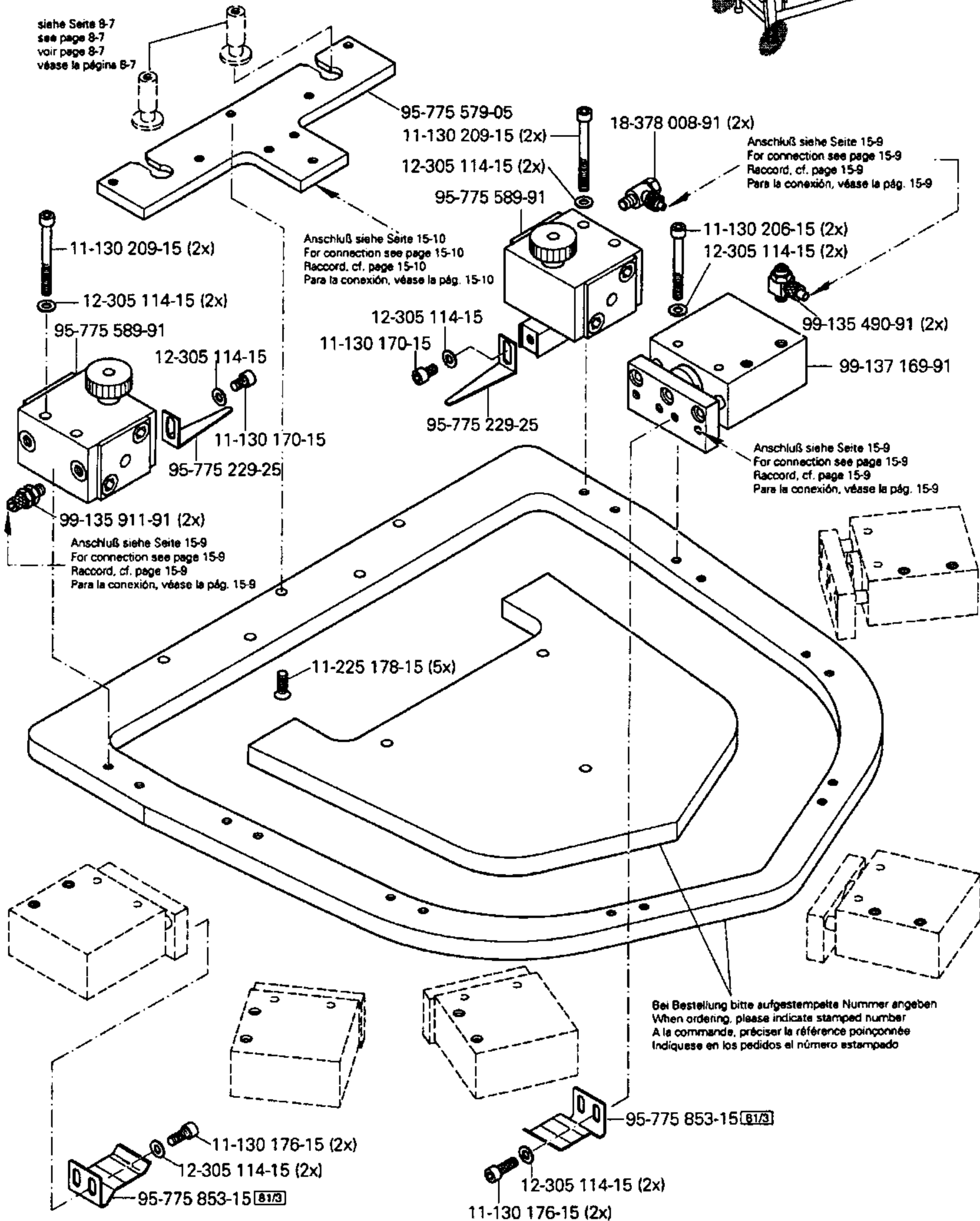
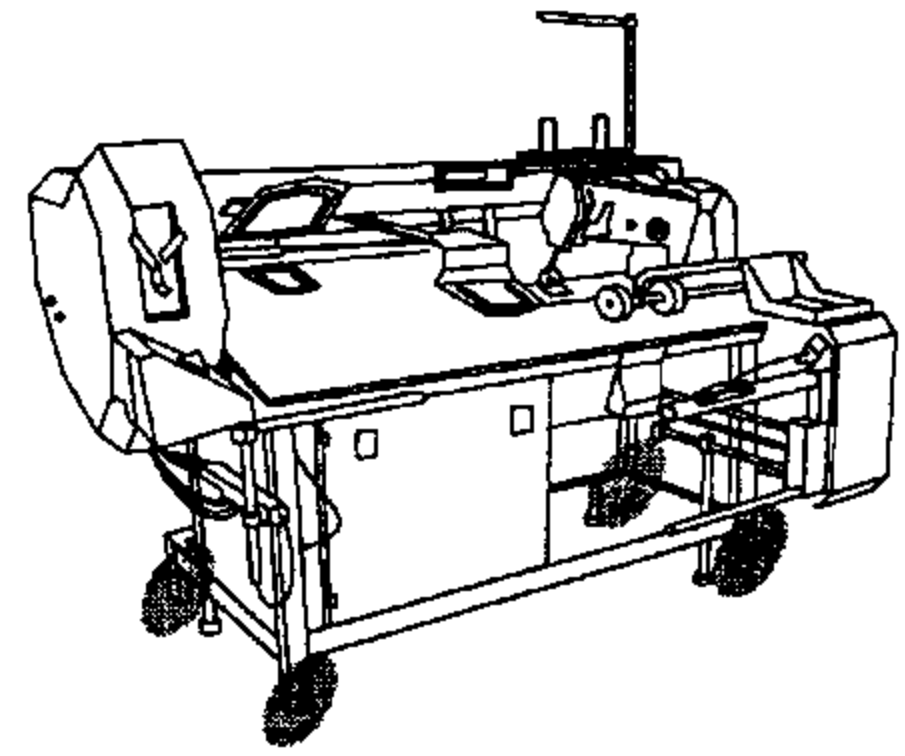
PFAFF 3588-04/020

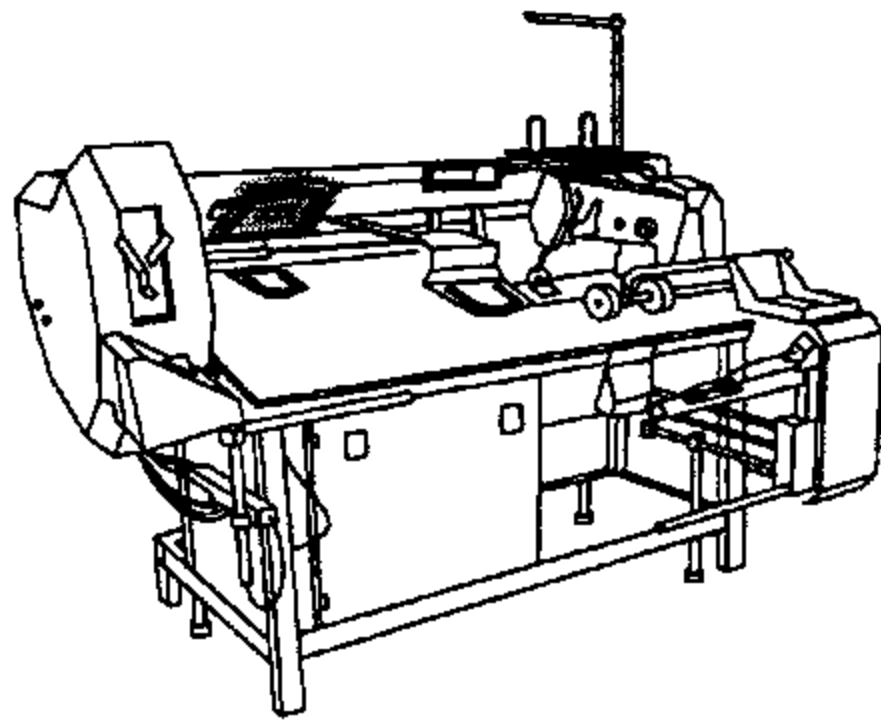



Ecken-Umbuggschieber
Edge folders
Glissière rempliage du coin
Remetedor de esquinas

PFAFF 3588-04/020

15.04

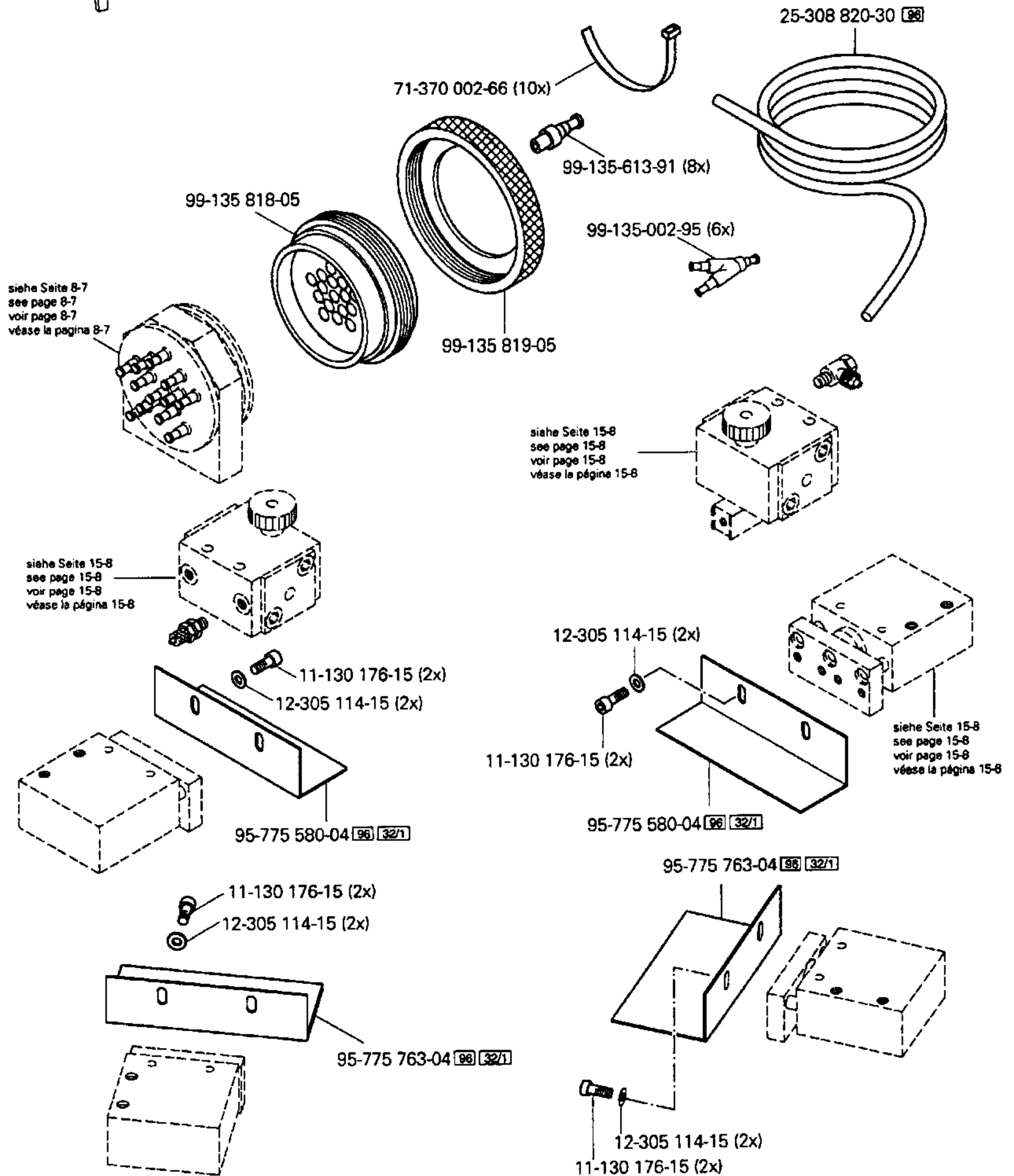

15.04

Ecken-Umbuggschieber
Edge folders
Glissière rempliage du coin
Remetedor de esquinas

PFAFF 3588-04/020

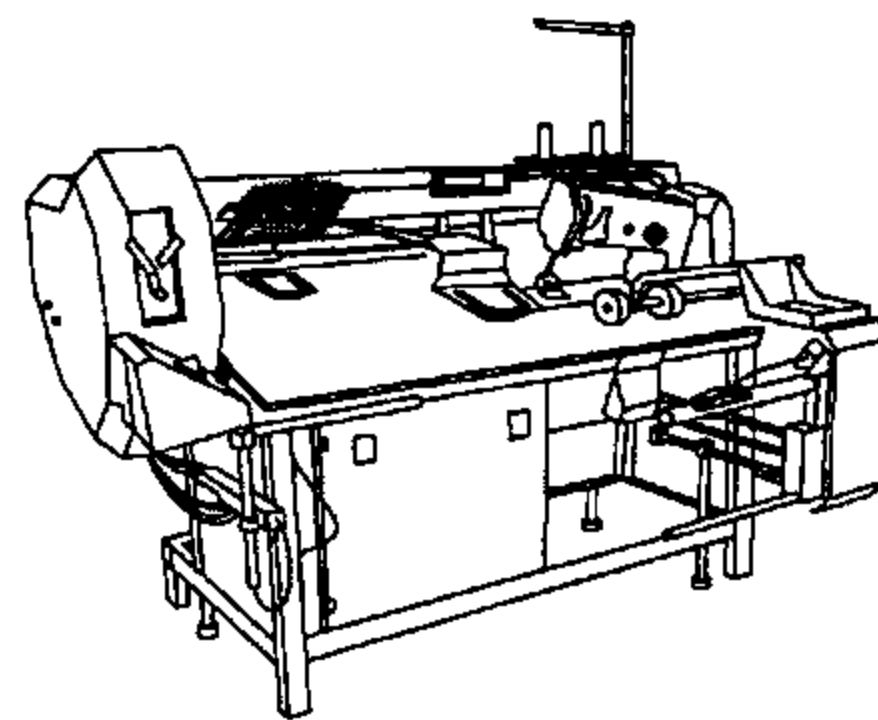

siehe Seite 15-8
see page 15-8
voir page 15-8
véase la página 15-8

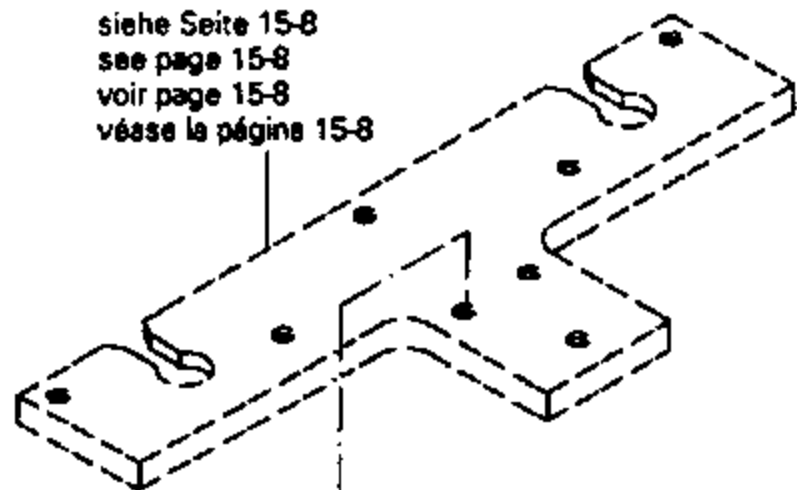

- 11-130 179-15 (3x)
- 12-335 151-15 (3x)

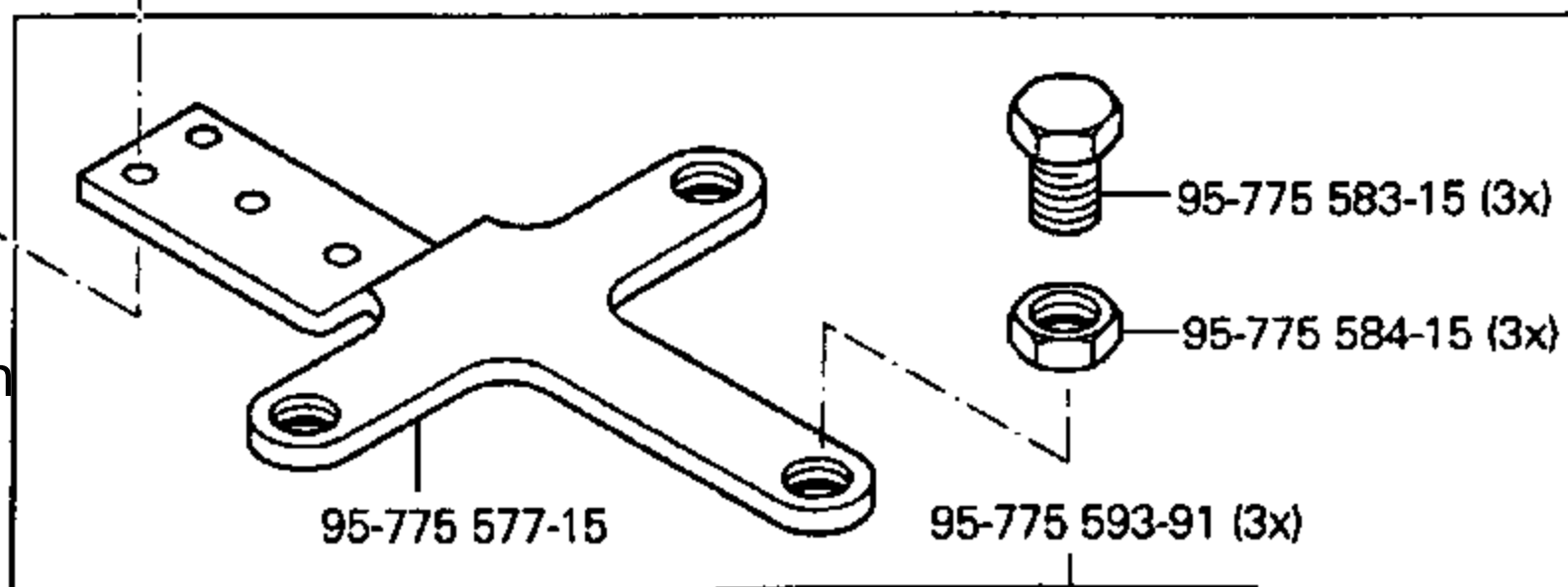

95-775 577-15

95-775 593-91 (3x)

95-775 583-15 (3x)

95-775 584-15 (3x)

95-775 594-91

91-291919-91 solenoid for the pocket holder.
91-291920-91 basic kit that is mounted to each machine when using the solenoid.

siehe Seite 15-8
see page 15-8
voir page 15-8
véase la página 15-8

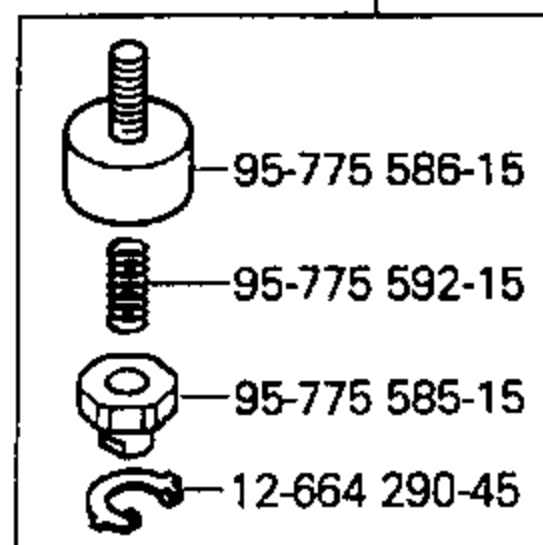
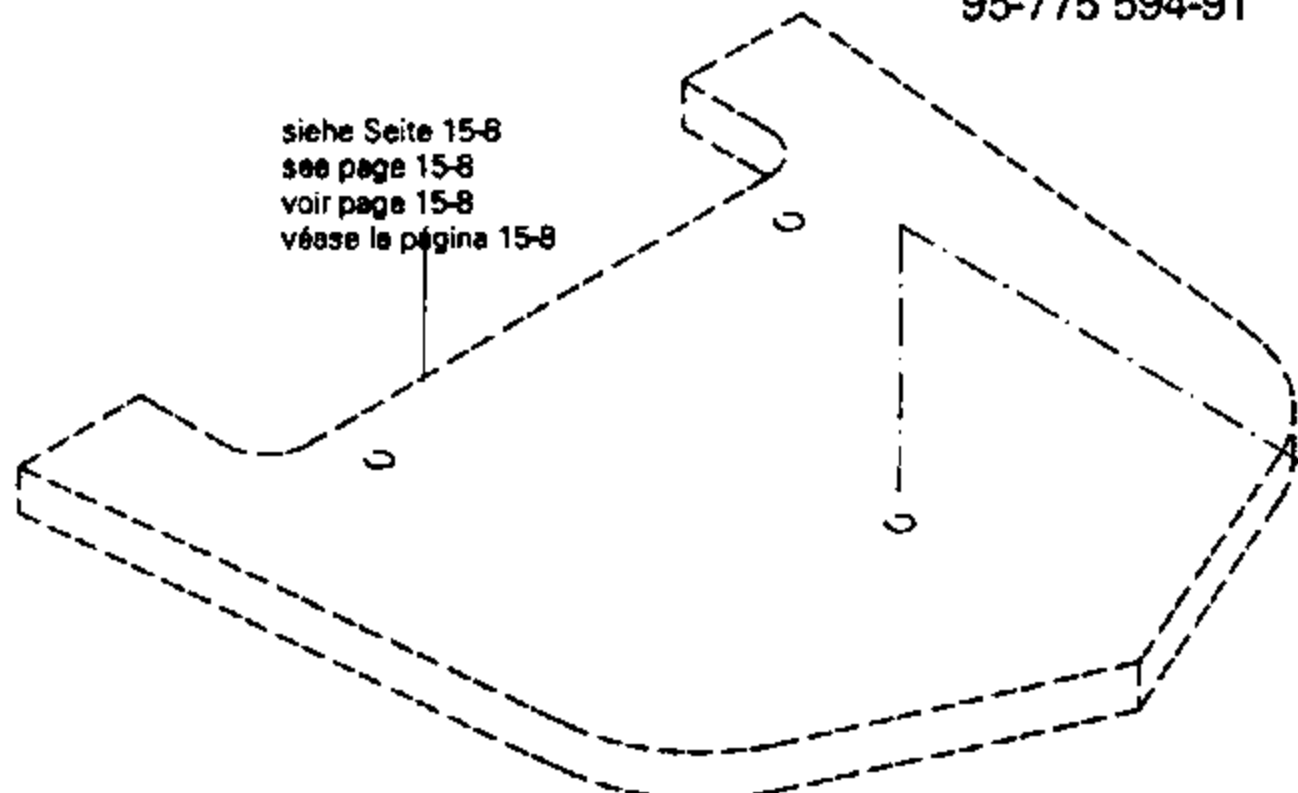

95-775 586-15

95-775 592-15

95-775 585-15

12-664 290-45

siehe Seite 15-8
see page 15-8
voir page 15-8
véase la página 15-8

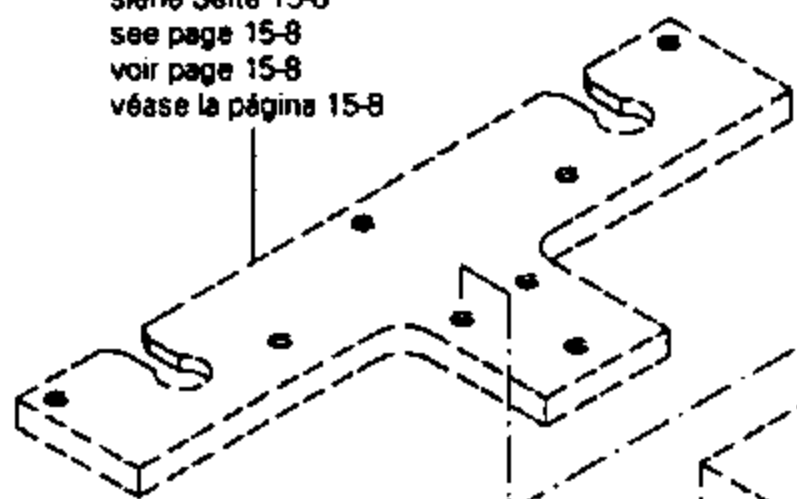

11-225 226-15 (3x)

12-335 151-15 (3x)

95-775 595-91

11-130 179-15 (3x)

95-775 583-15 (3x)

95-775 584-15 (3x)

95-775 578-15

95-775 593-91 (3x)

siehe Seite 15-8
see page 15-8
voir page 15-8
véase la página 15-8

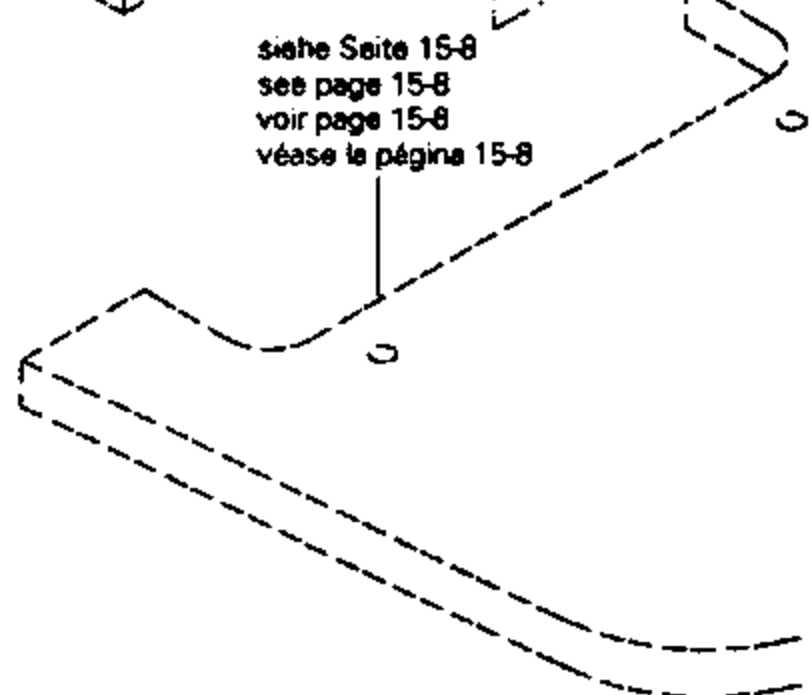

95-775 586-15

95-775 592-15

95-775 585-15

12-664 290-45

11-225 226-15 (3x)

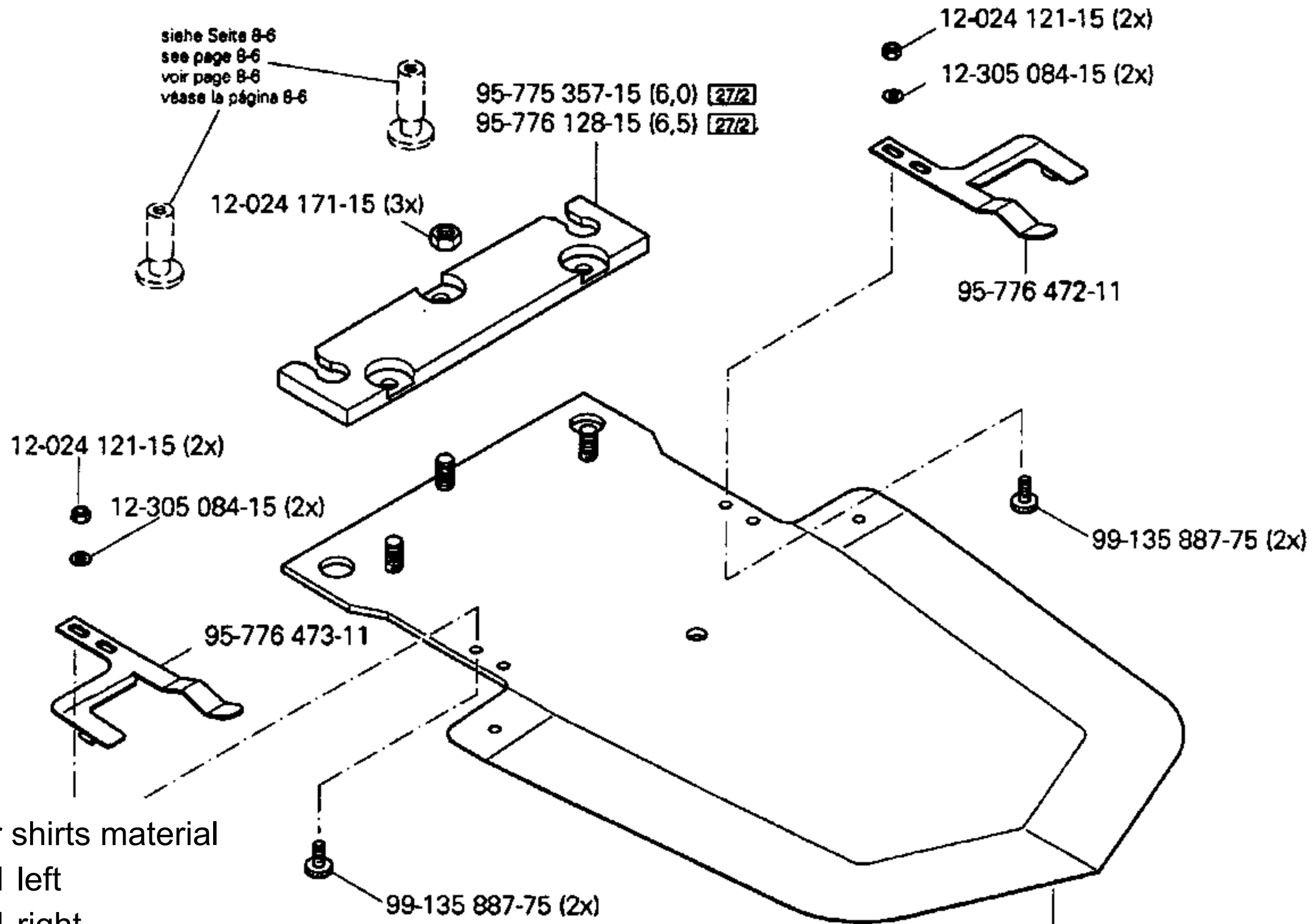
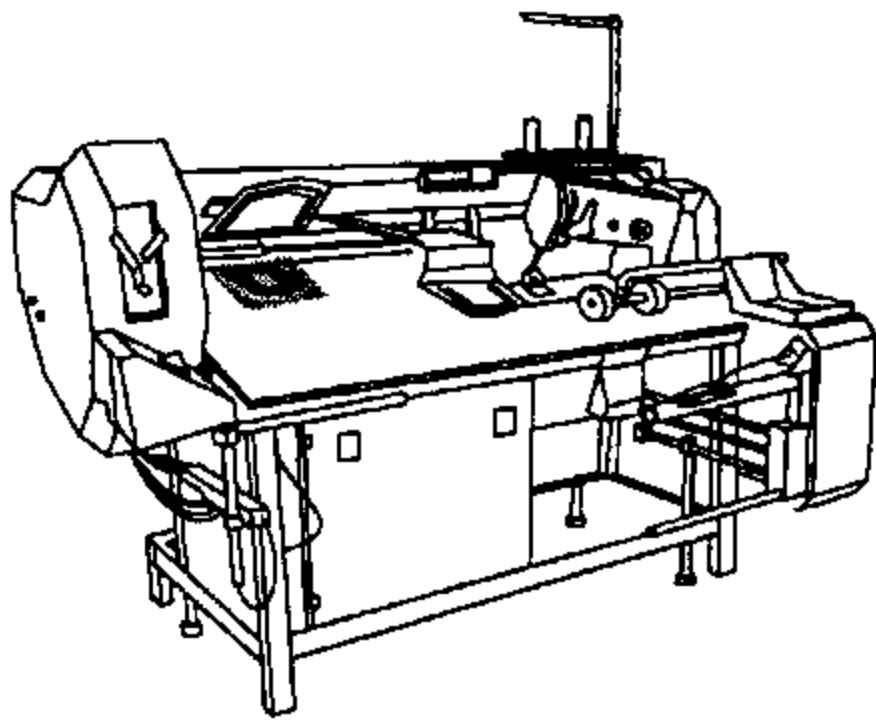

Pocket stops for shirts material
 # 95-776 475-91 left
 # 95-778 476-91 right

Bei Bestellung bitte aufgestempelte Nummer angeben
 When ordering, please indicate stamped number
 A la commande, préciser la référence poinçonnée
 Indíquese en los pedidos el número estampado

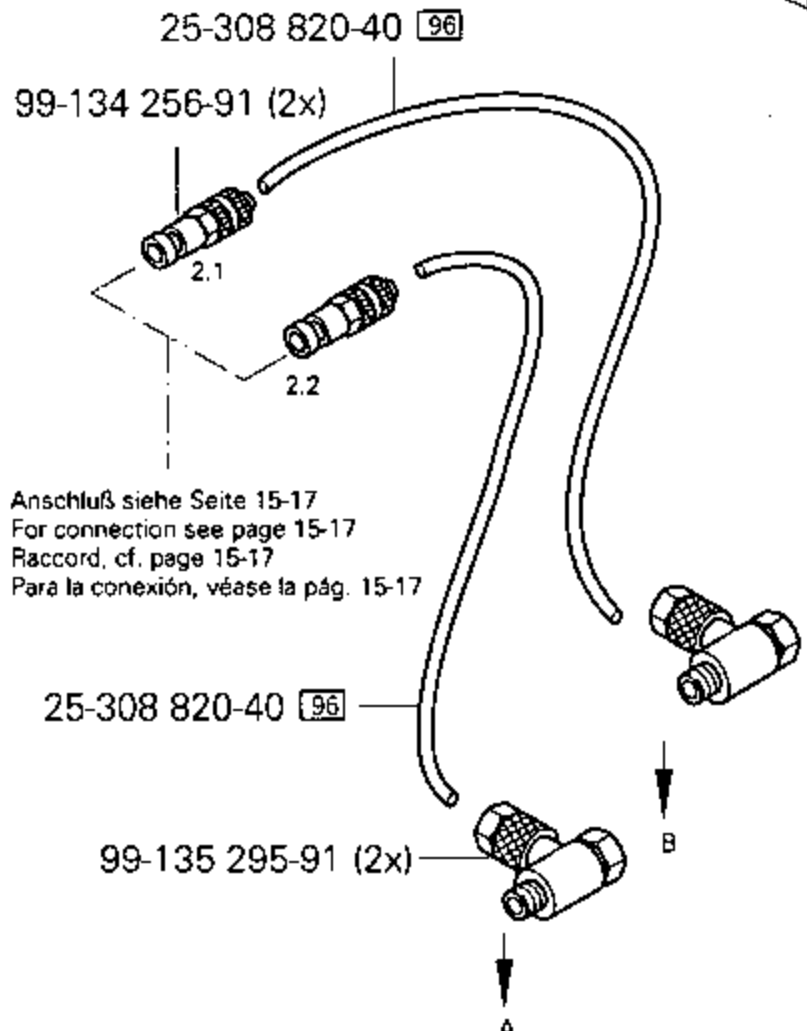
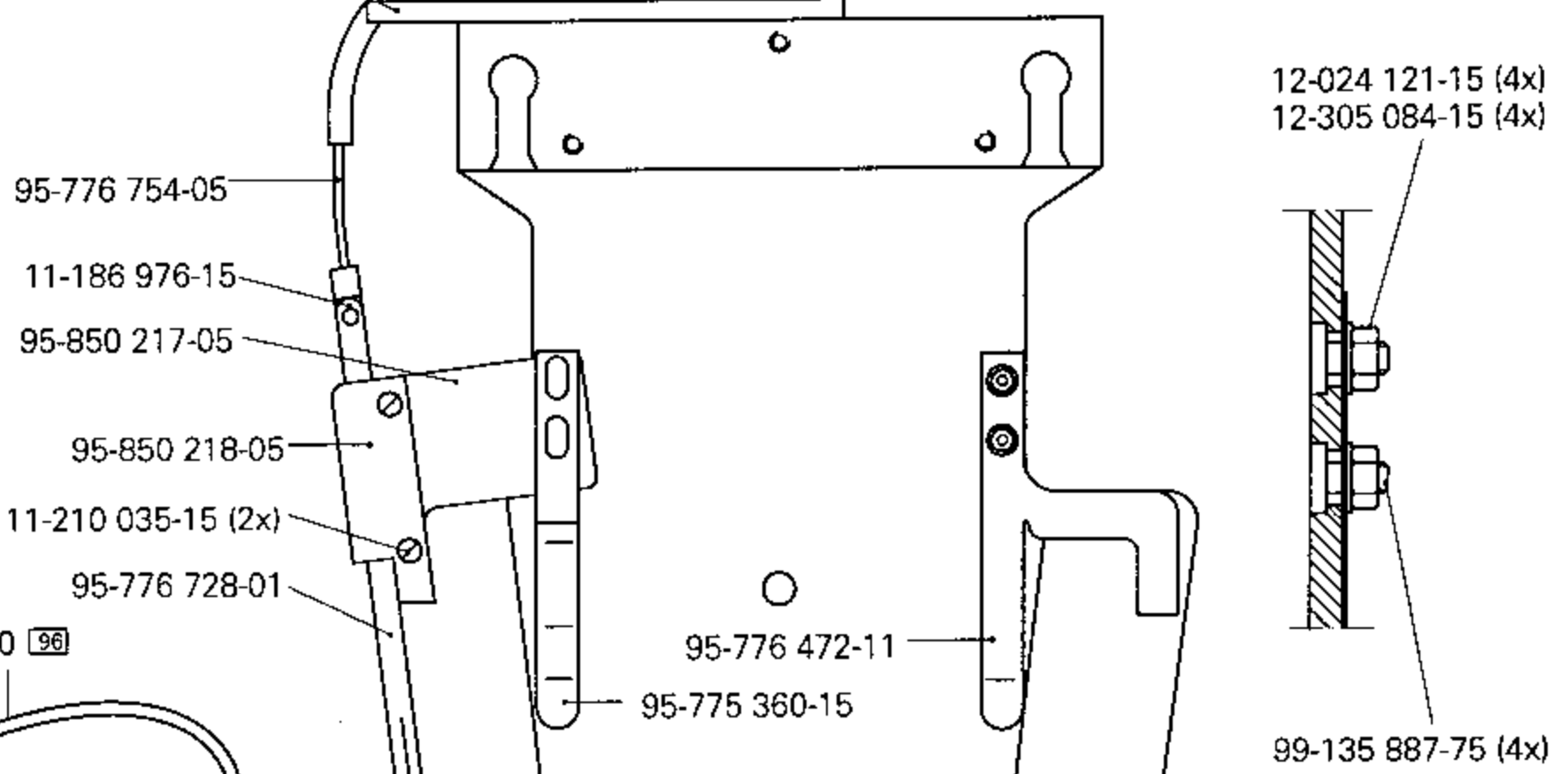
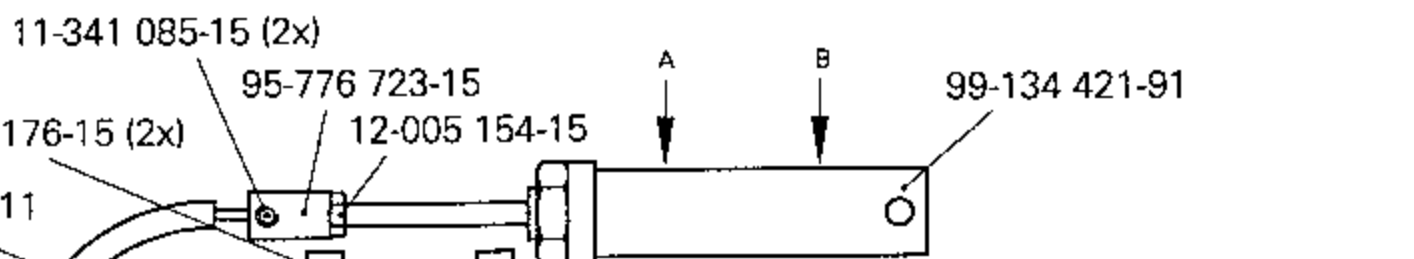
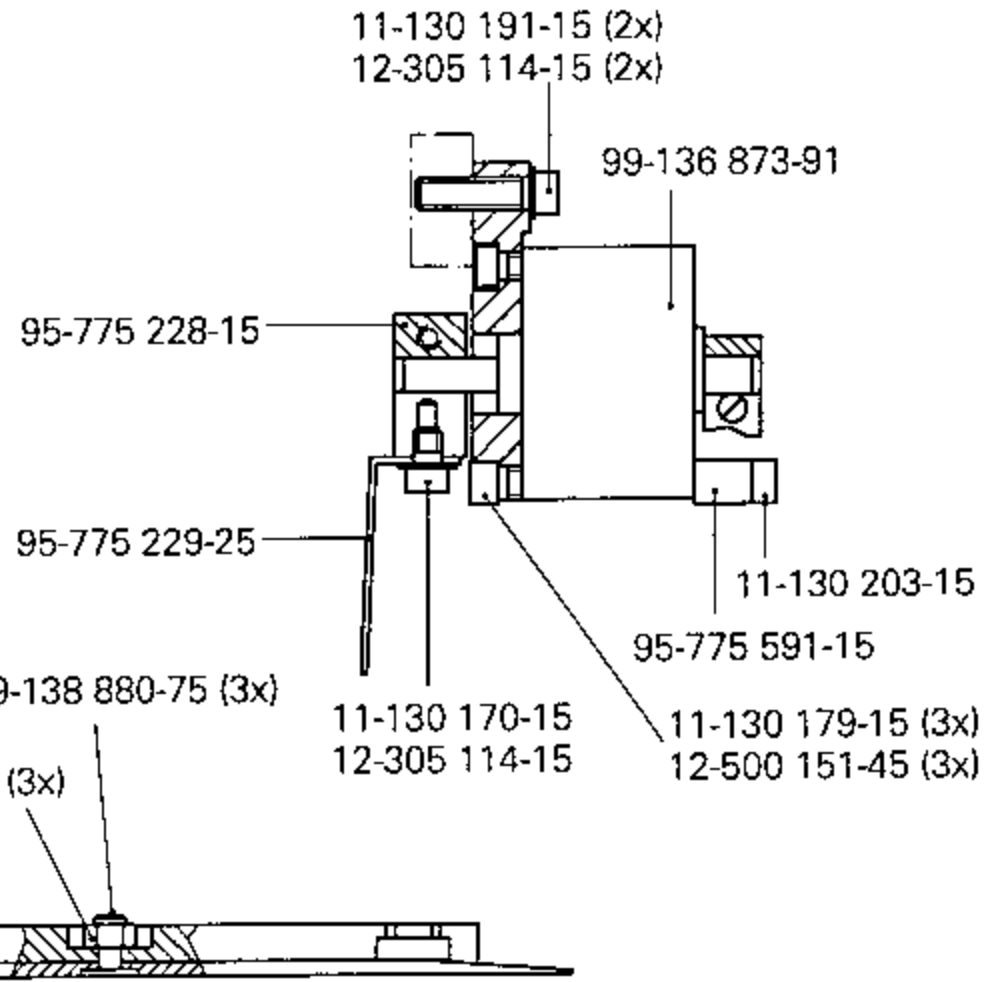
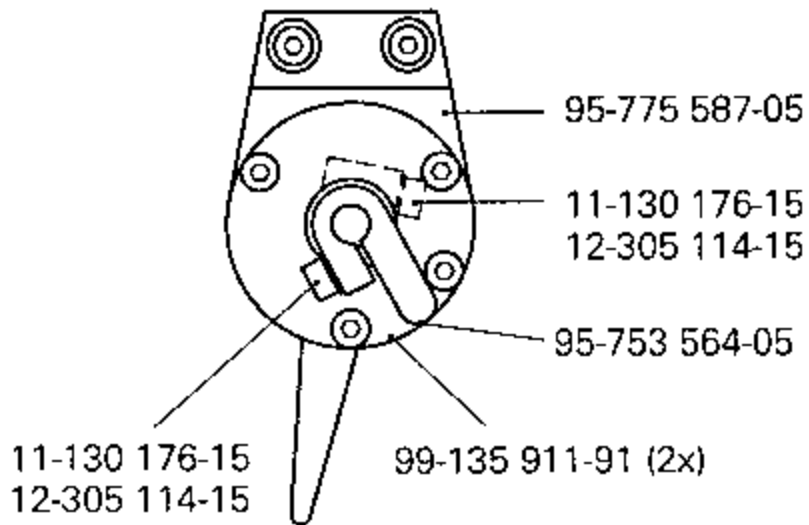
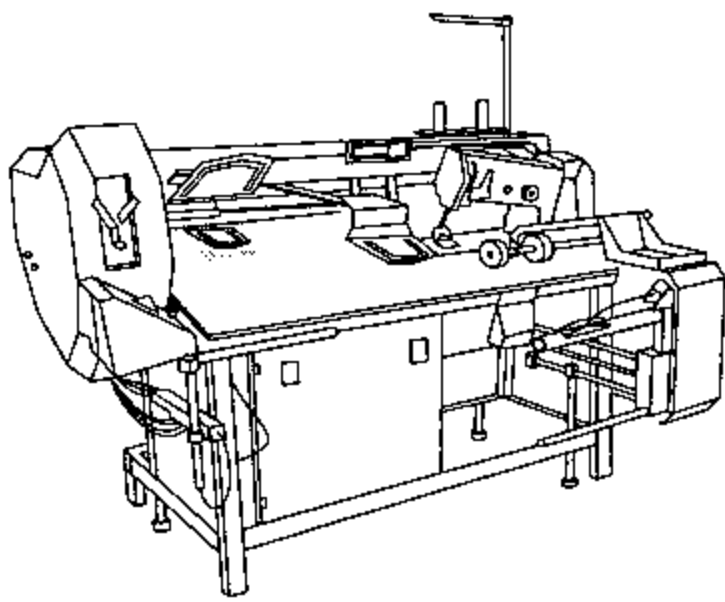

Anschluß siehe Seite 15-17
 For connection see page 15-17
 Raccord, cf. page 15-17
 Para la conexión, véase la pág. 15-17

15.05

Taschenblech
 Pocket plate
 Gabarit de poche
 Chapa del bosillo PFAFF 3588-04/020

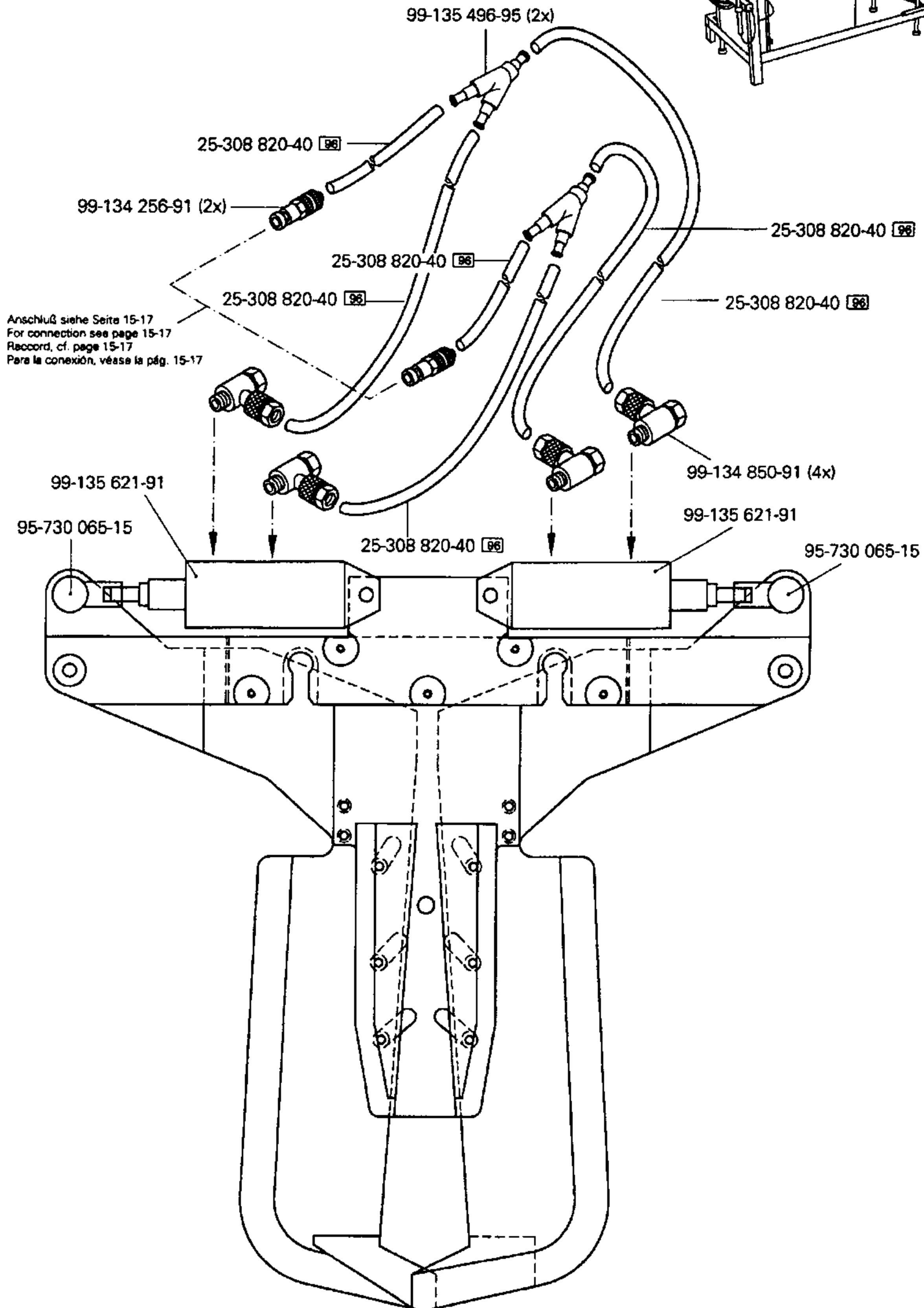
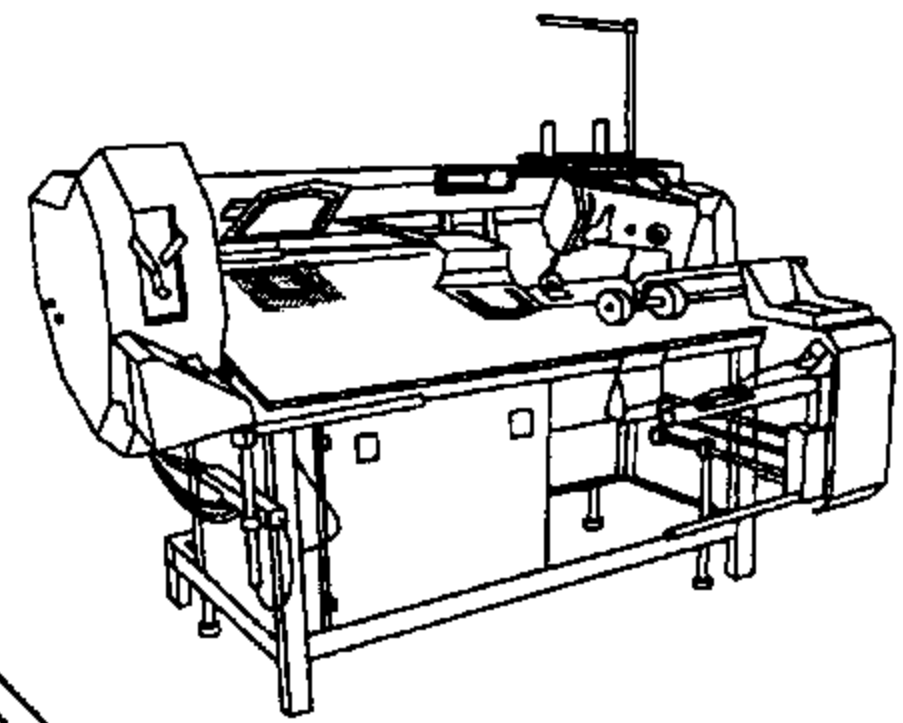

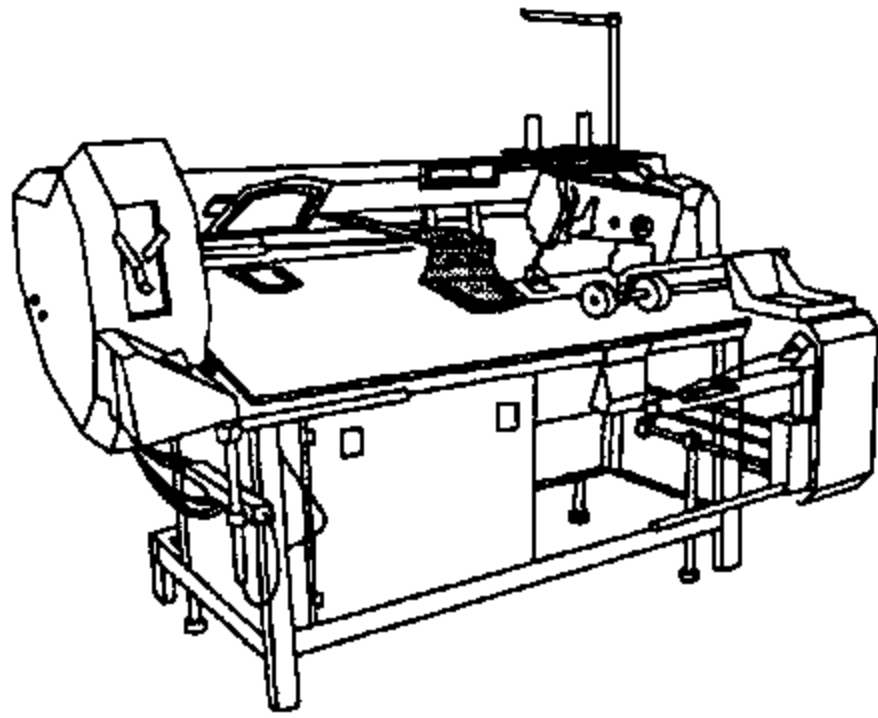

Schablonenblech
Jig plate
Gabarit
Plantilla

PFAFF 3588-04/020

15.06

ROLL FLAP is when the flap is first sewn on and then turned for top stitching.

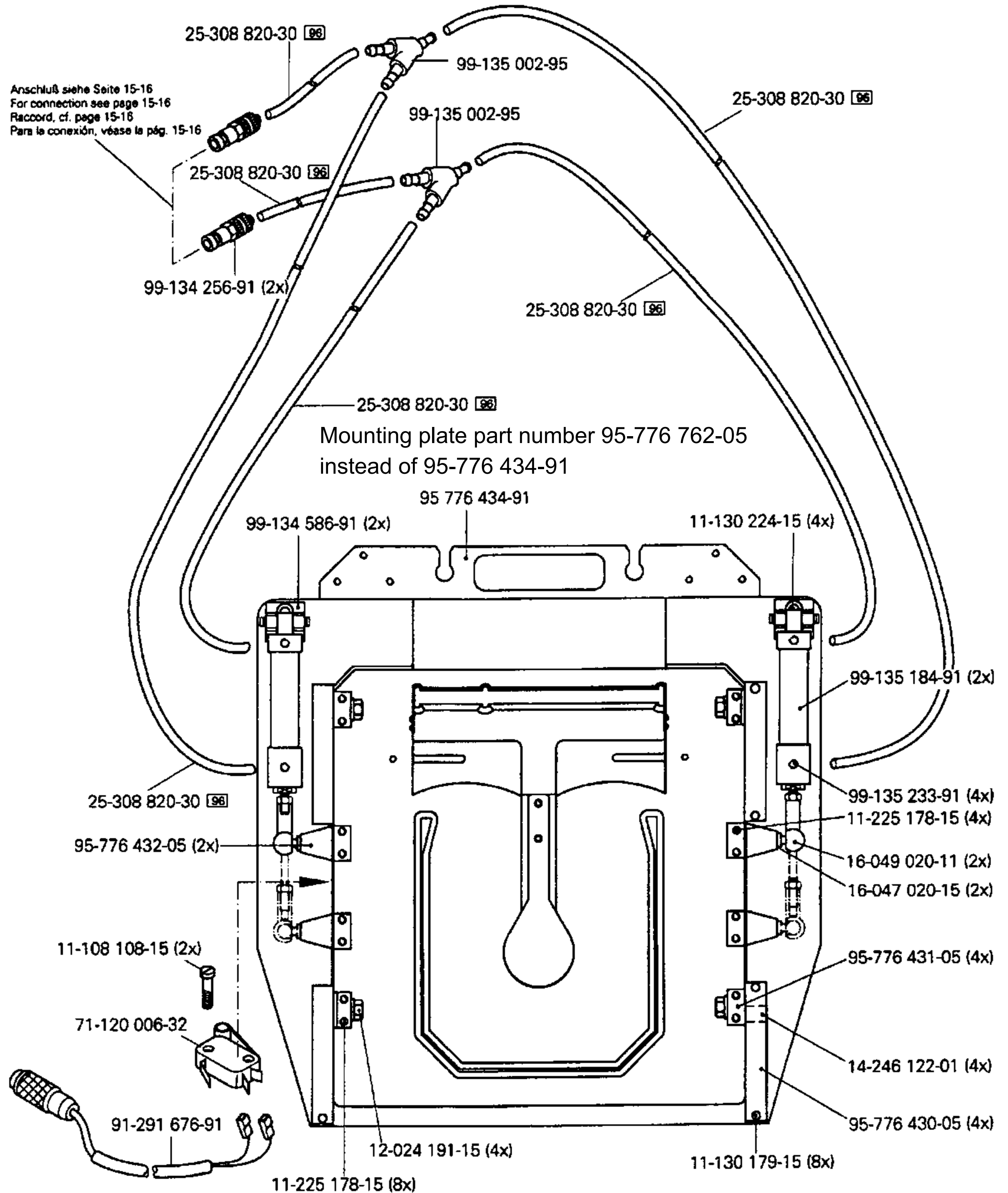

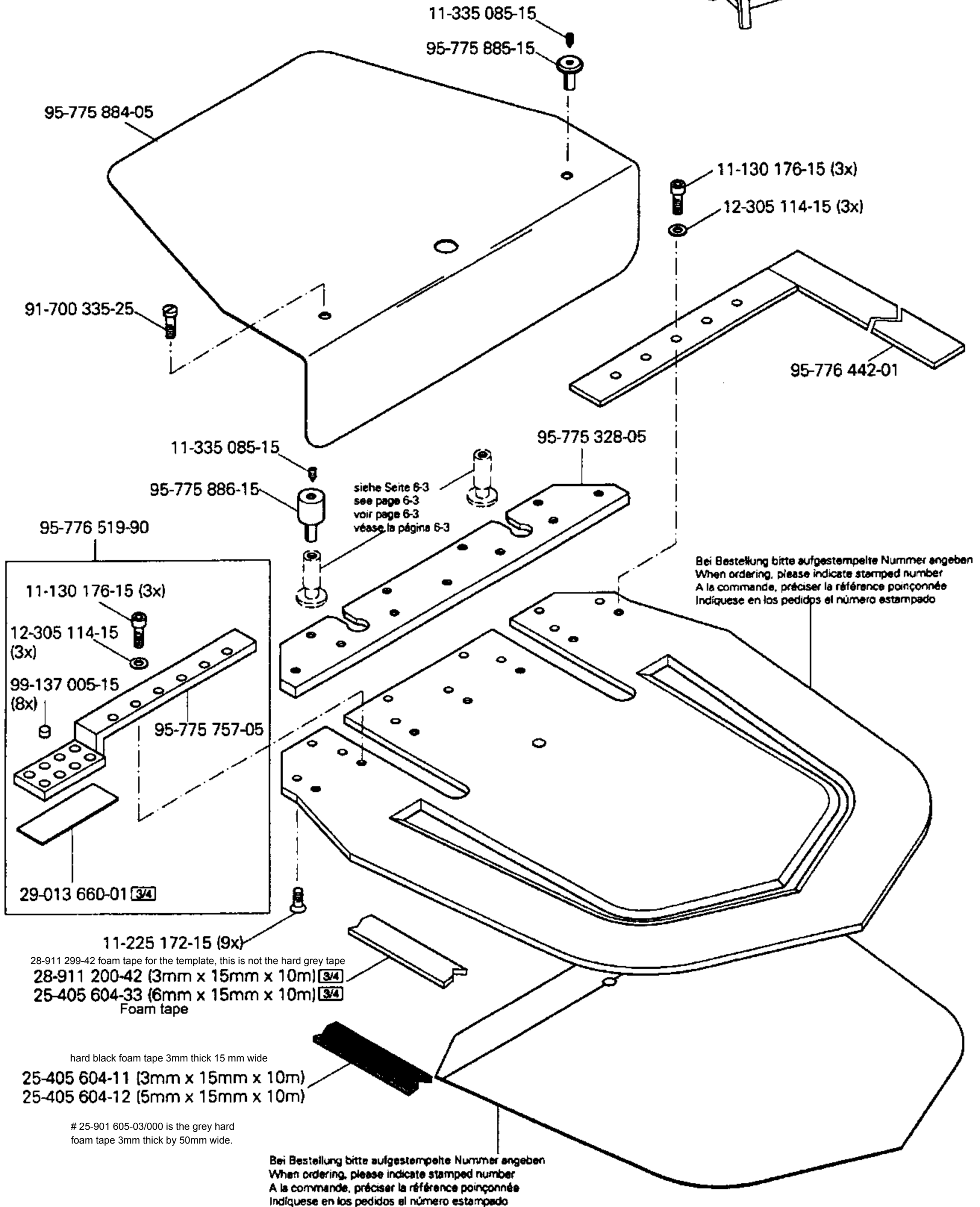
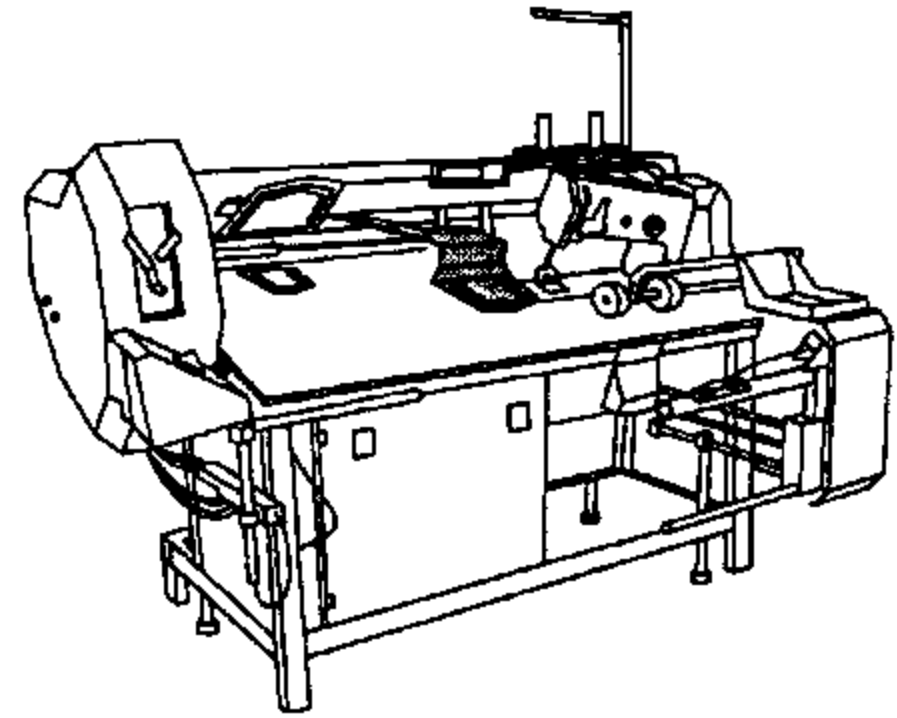

15.07

Anbausatz für variablen Näh Schlitz und Platten
 Add-on kit for variable needle slot and flange
 Jeu de pièces adaptables fente de couture variable et rabats
 Juego de piezas acoplables pararanura de costura variable y carteras PFAFF 3588-04/020

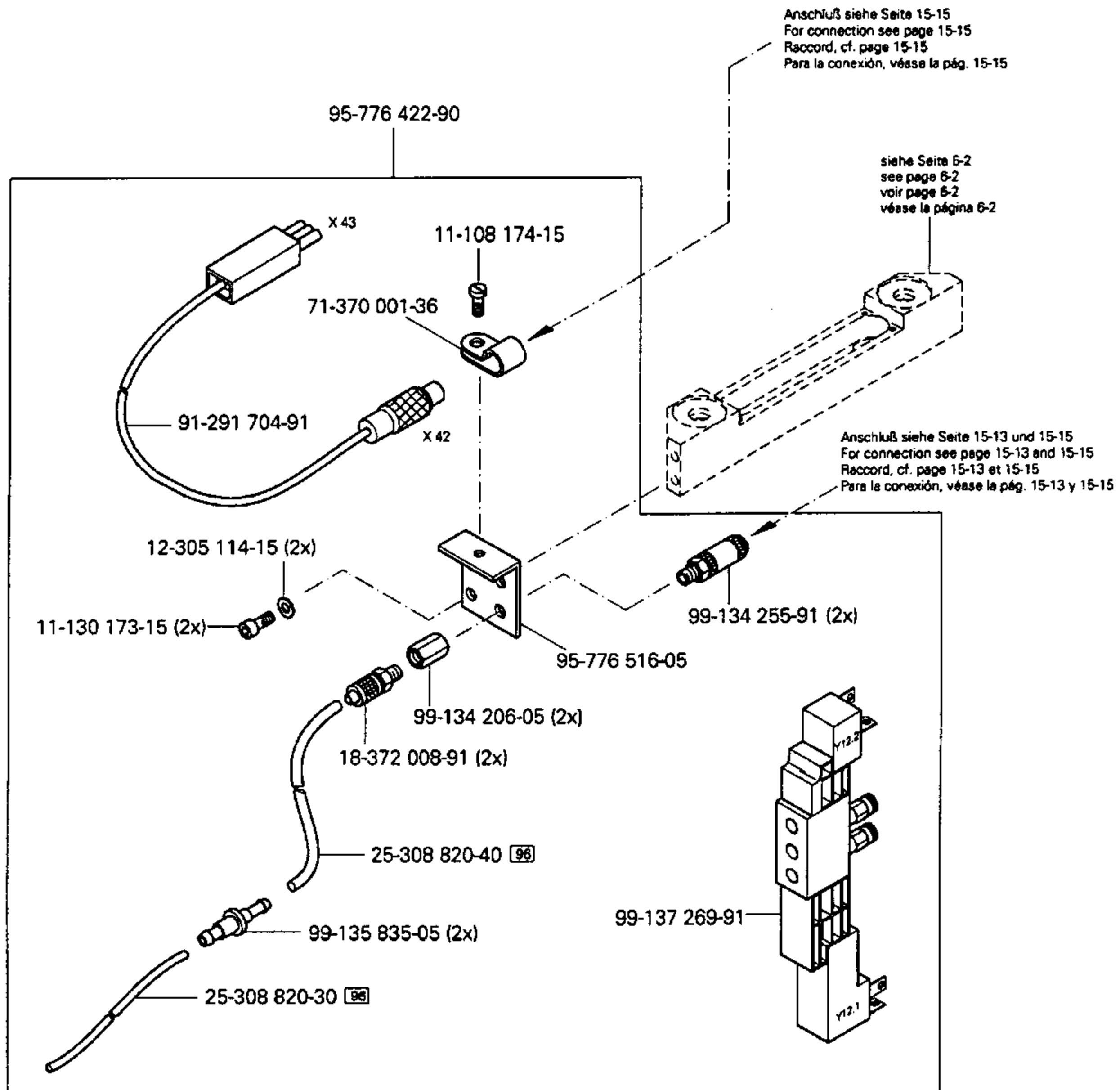
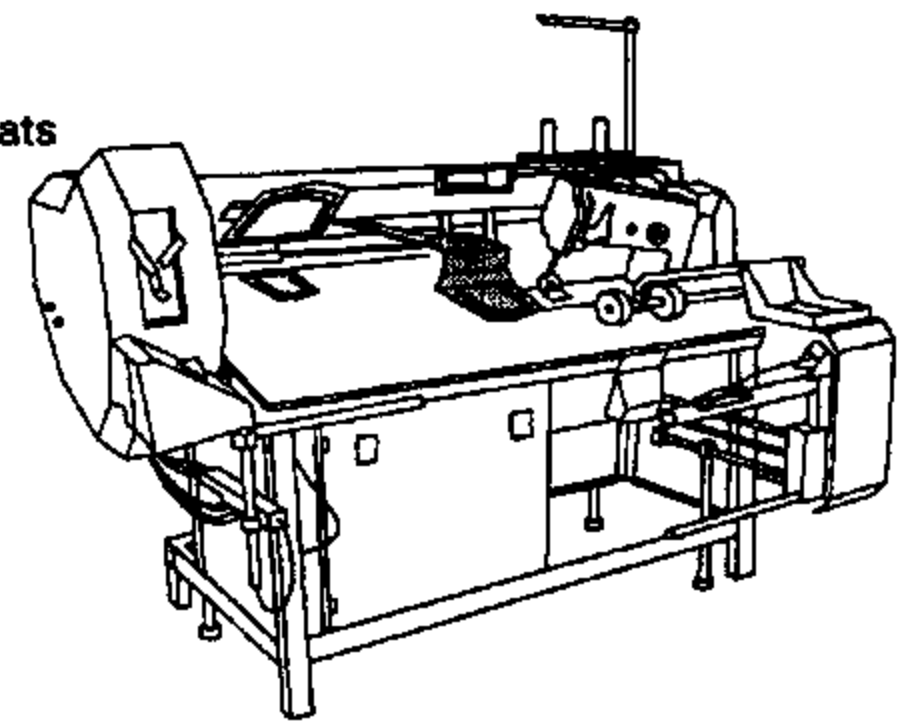

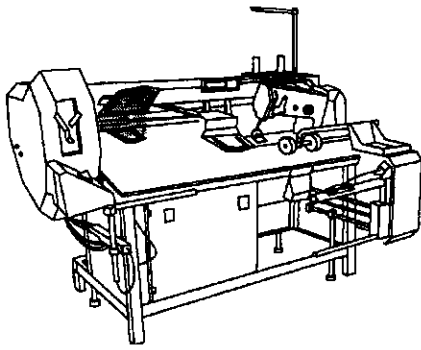

Anbausatz für geteiltes Taschenblech
 Add-on kit for split pocket plate
 Jeu de pièces adaptables pour gabarit de poche segmenté
 Juego de piezas acoplables para
 chapa de bolsillo bipartida

PFAFF 3588-04/020

15.08

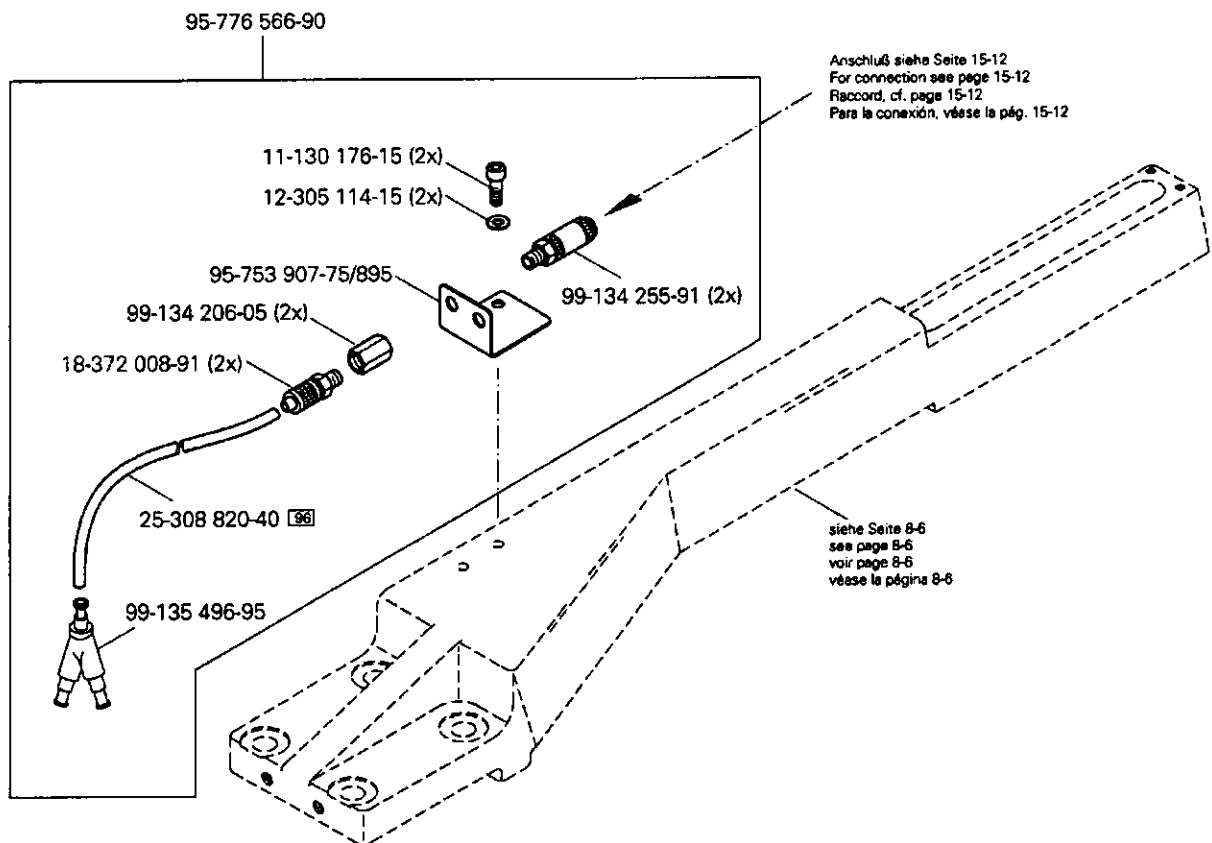

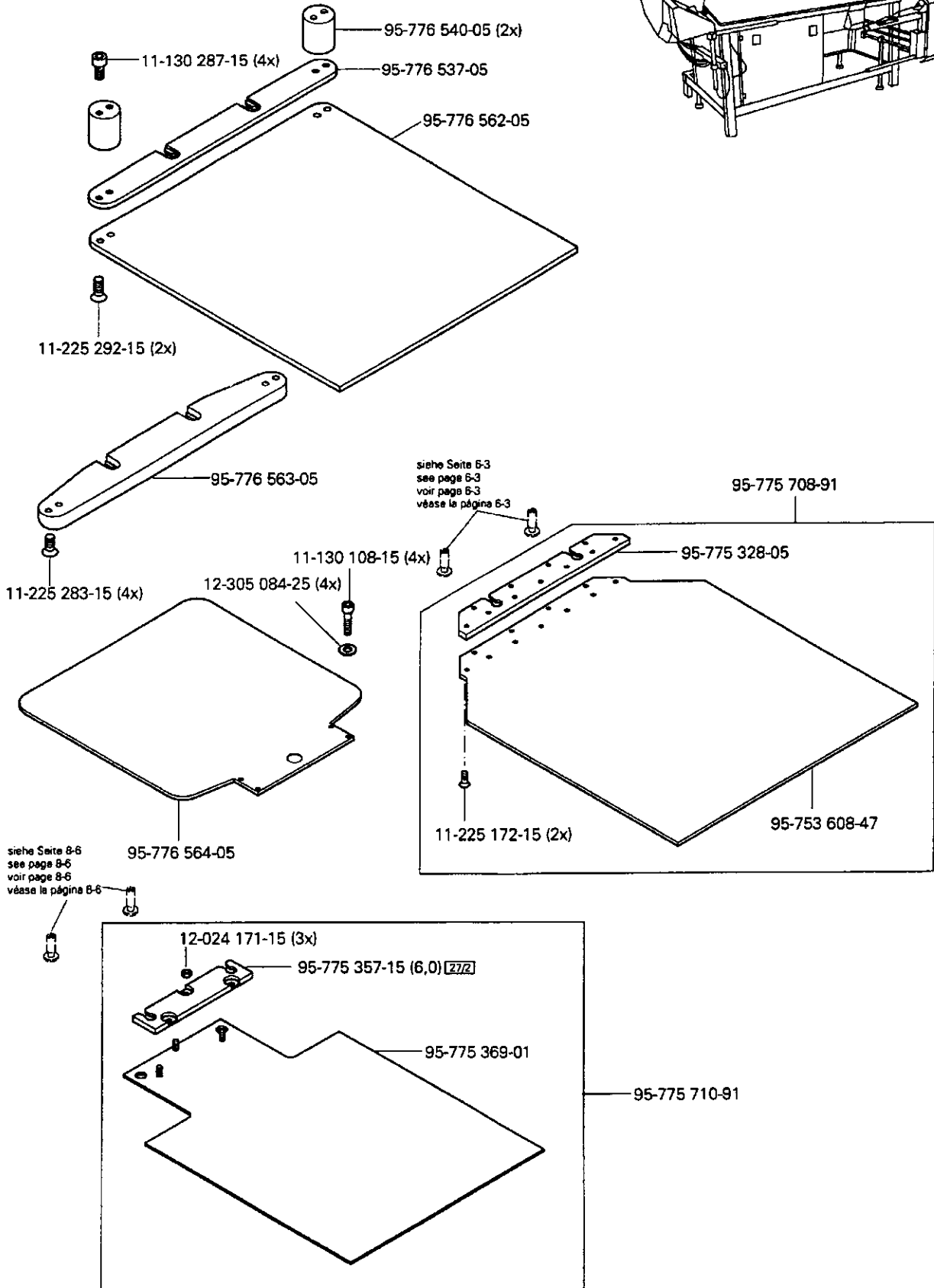
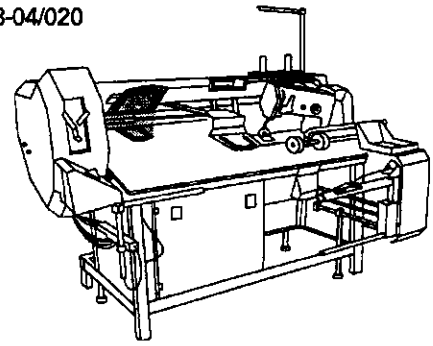

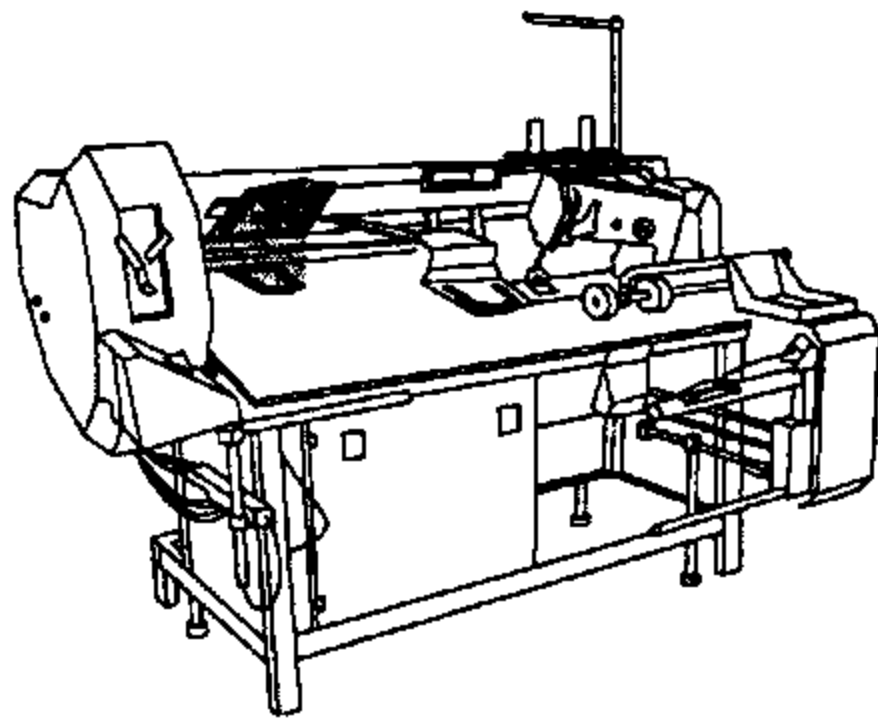

Etikettenpositioniereinrichtung
 Label positioning device
 Dispositif de positionnement d'étiquettes
 Dispositivo posicionador de etiquetas

PFAFF
 3588-04/020

15.10

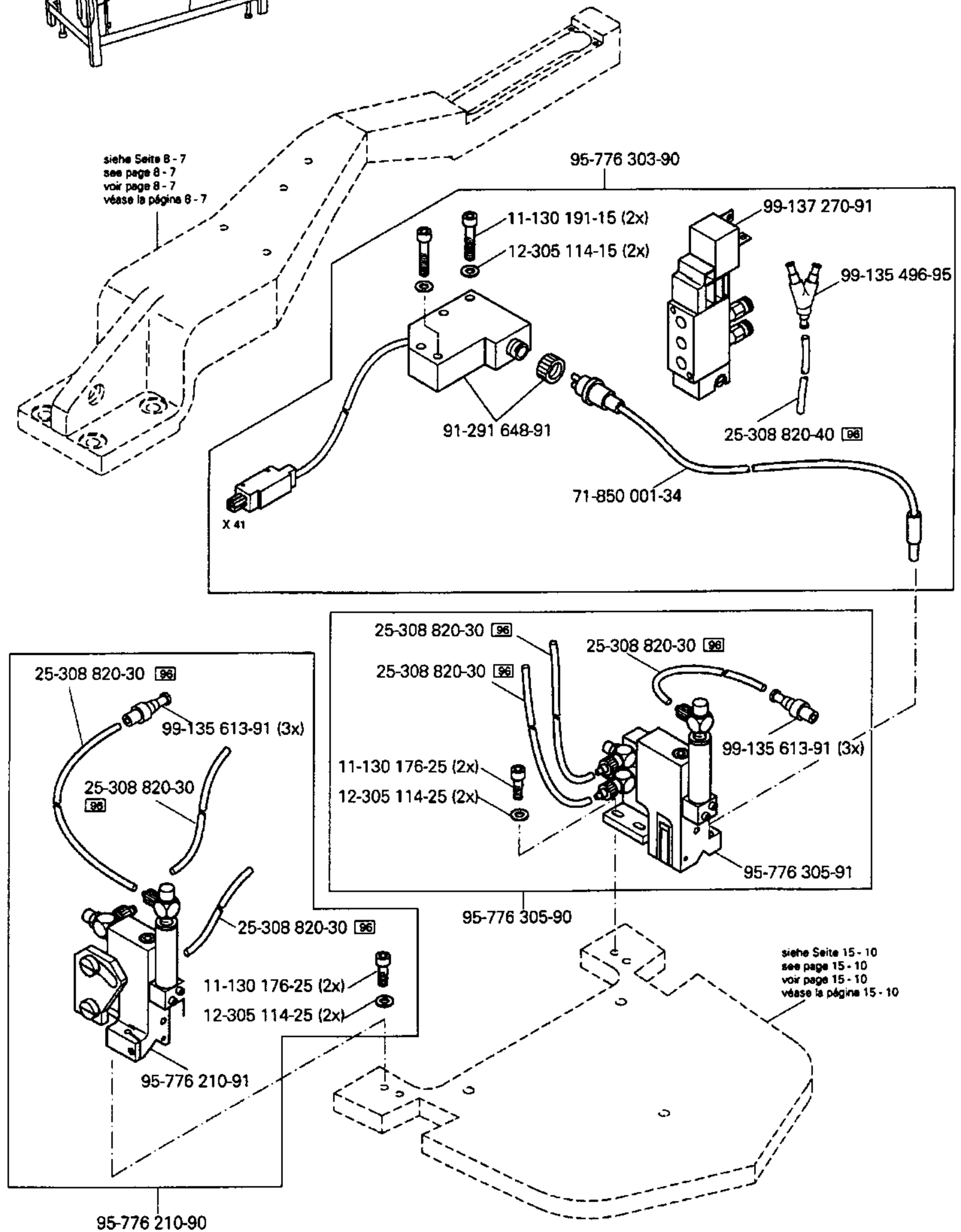

15.11

Fußtaster mit Leitung
 Foot control with cord
 Interrupteur au pied, avec câble
 Interruptor de pie, con cable

PFAFF 3588-04/020

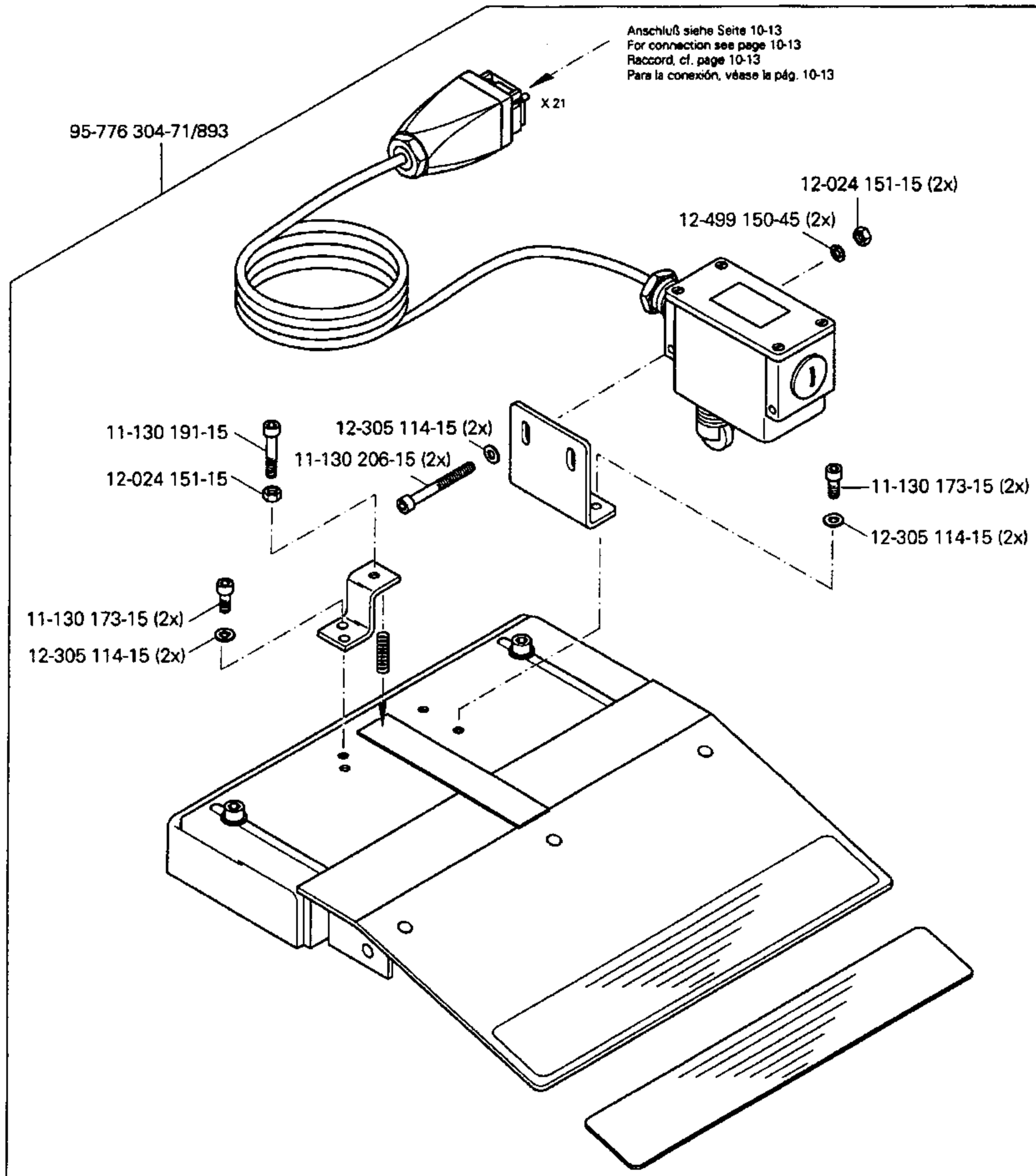

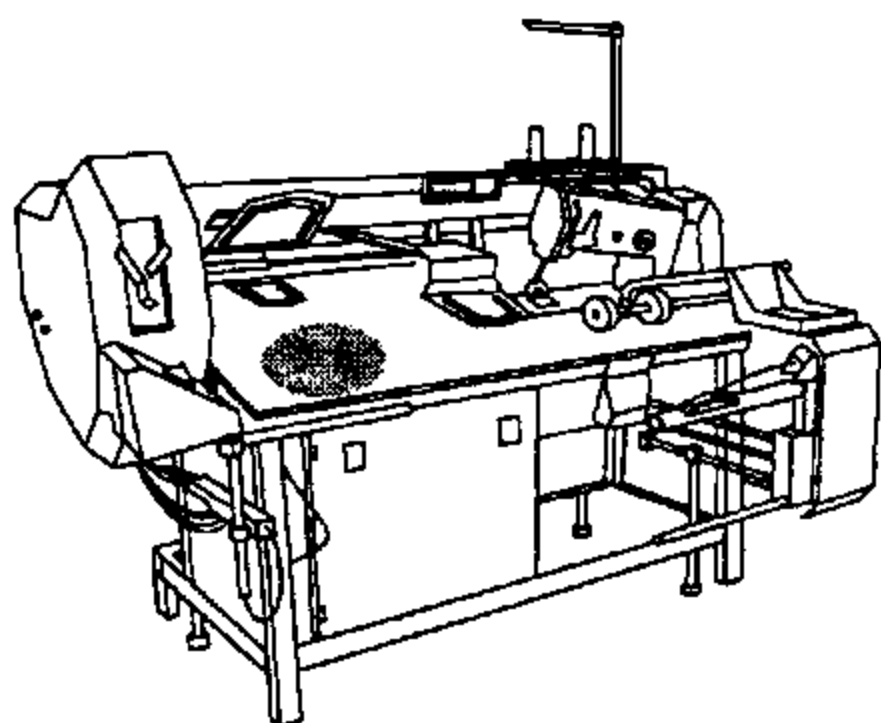

siehe Seite 15-14
 see page 15-14
 voir page 15-14
 véase la página 15-14

siehe Seite 4-1
 see page 4-1
 voir page 4-1
 véase la página 4-1

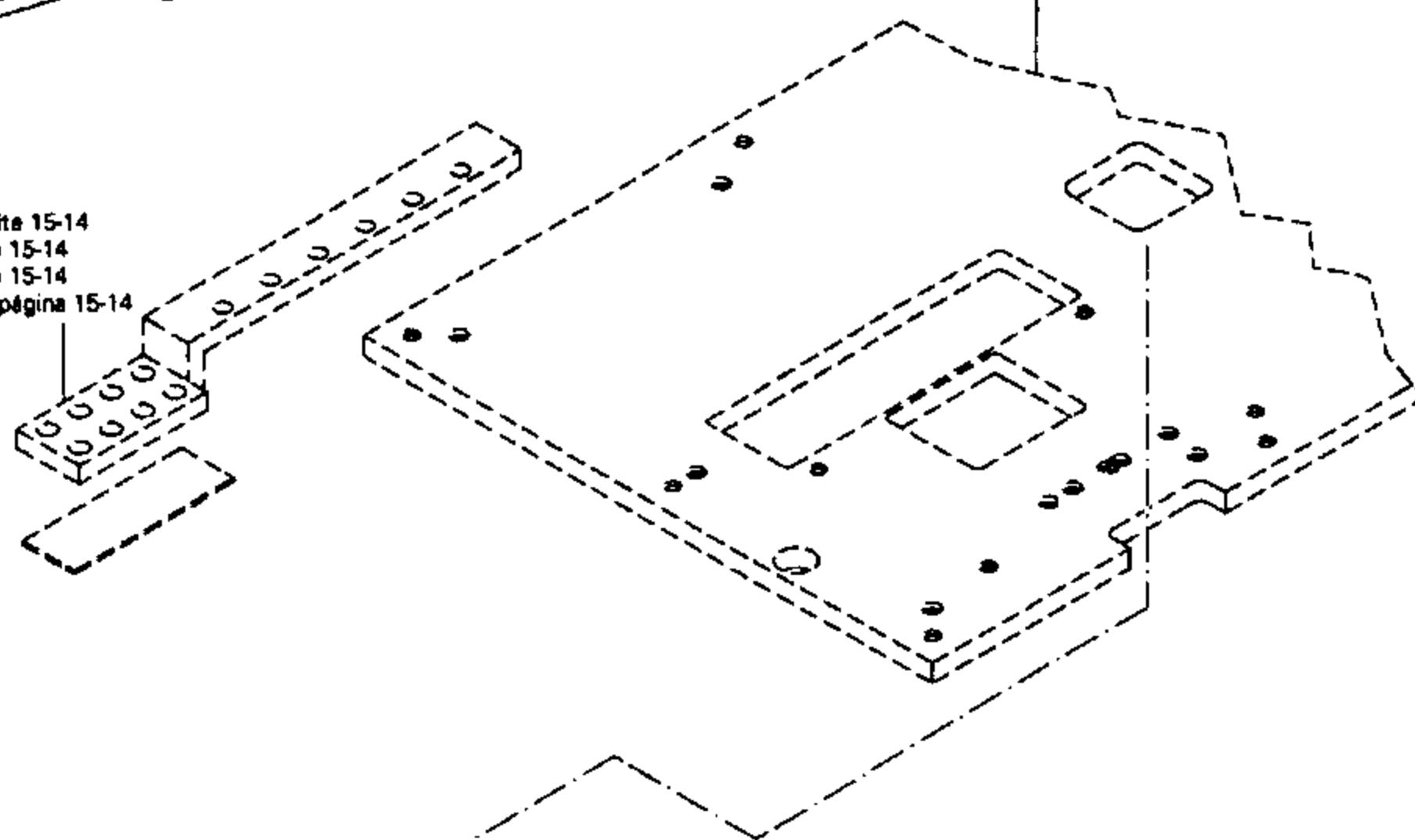

91-291 598-90

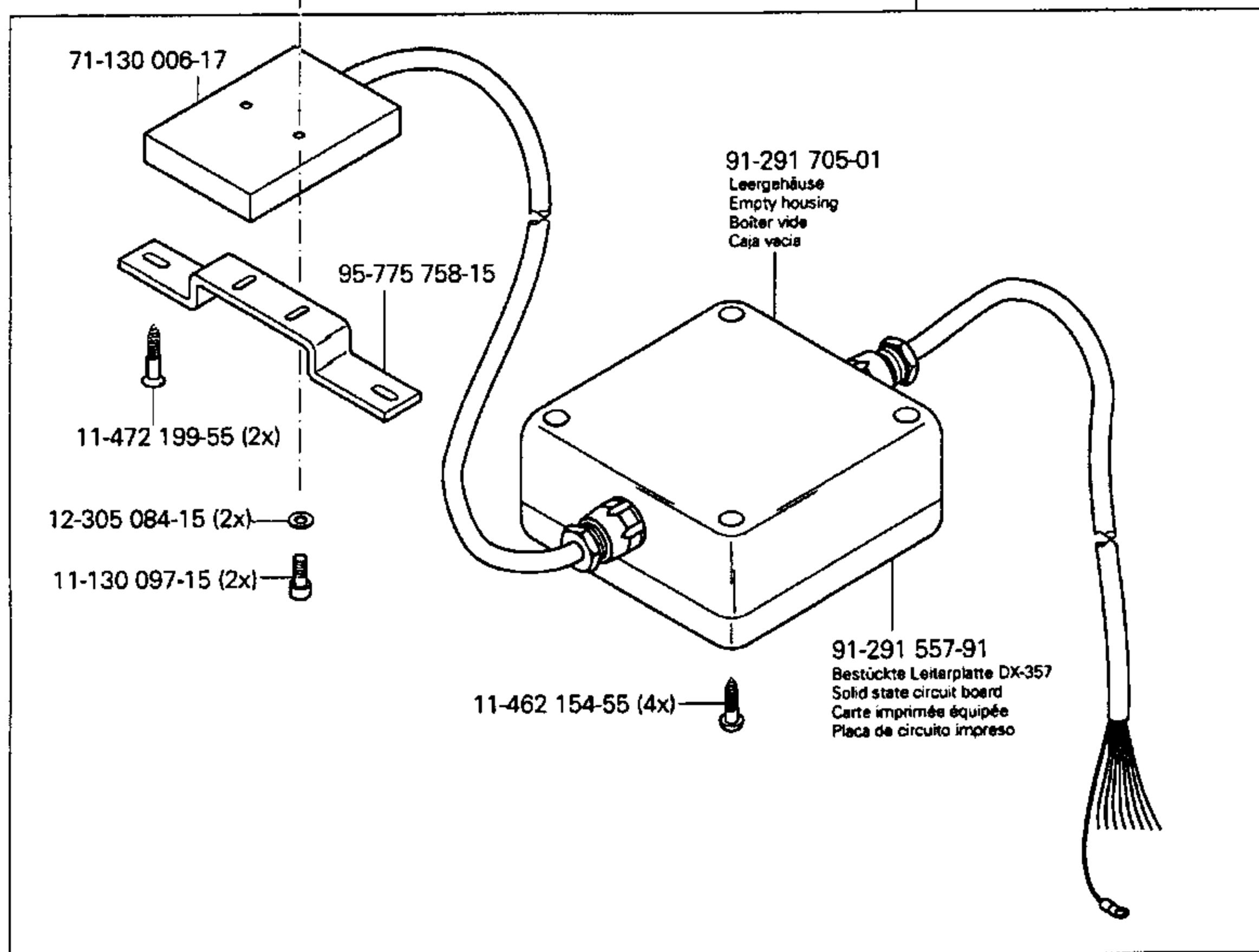

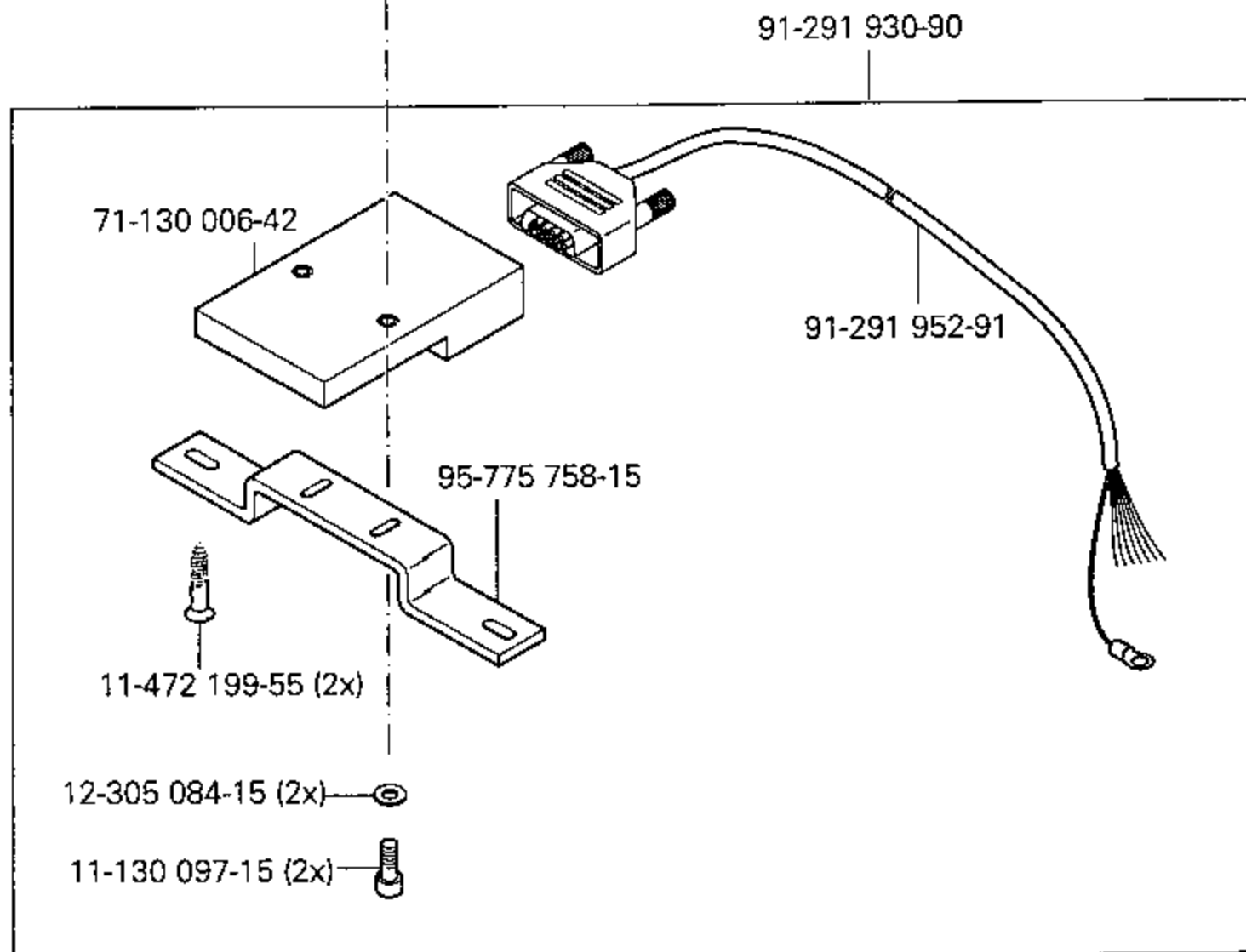
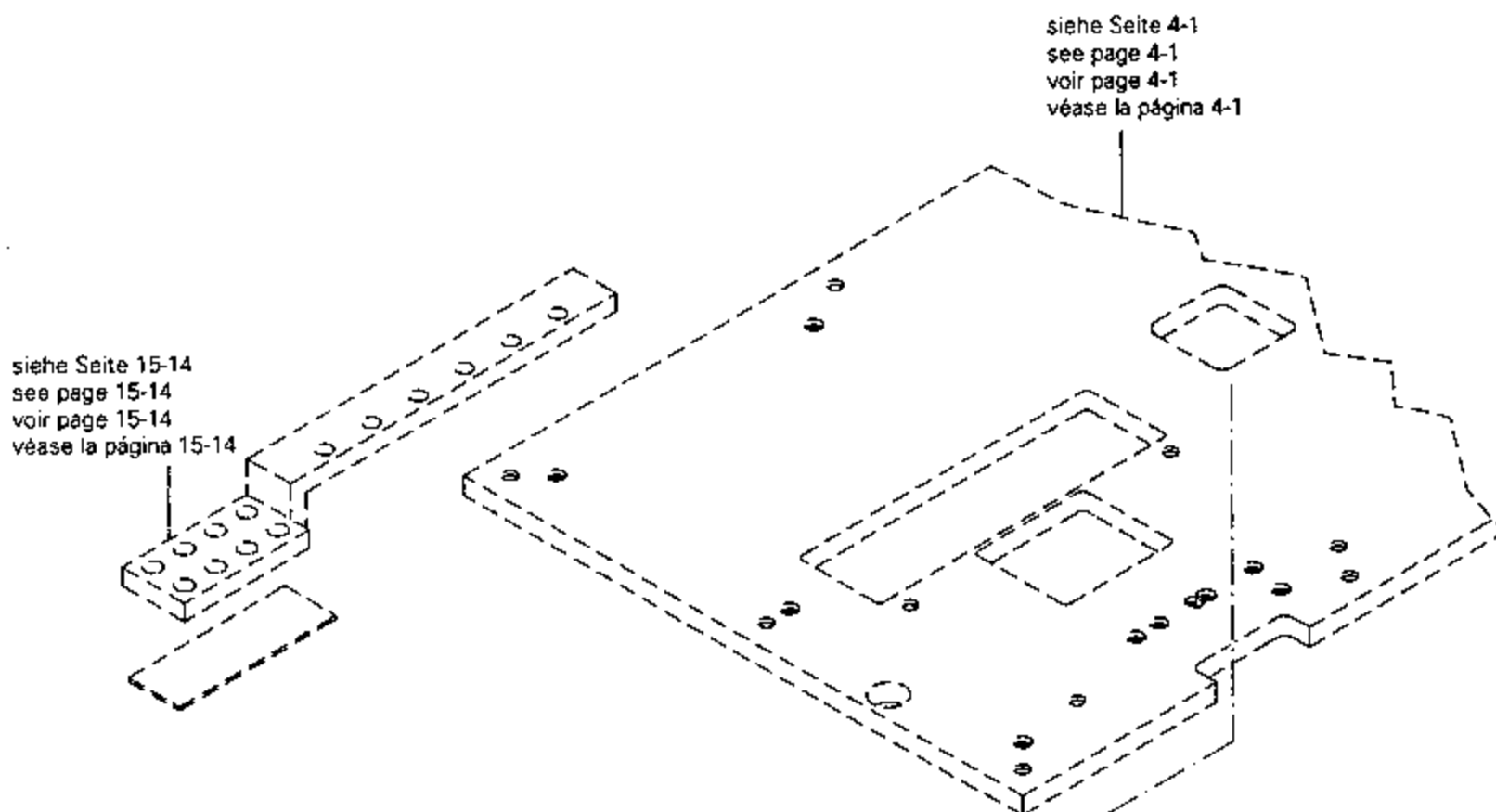
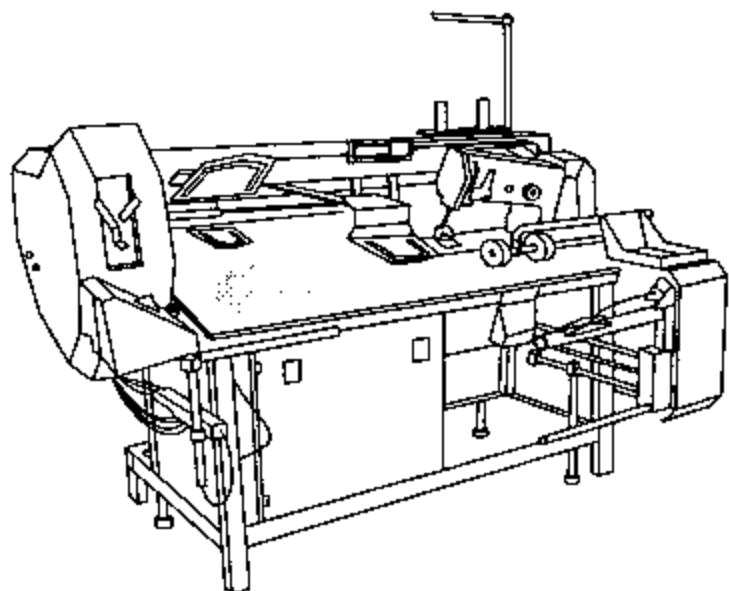

No.	Seite Page Pages Página	No.	Seite Page Pages Página	No.	Seite Page Pages Página	No.	Seite Page Pages Página
11-032 402-15	5-1	11-130 108-15	6-6, 15-18	11-130 293-15	3-12, 3-17, 3-22, 5-1, 7-5, 10-3, 15-3, 15-6	11-132 223-15	3-19
11-032 582-15	15-7	11-130 113-15	15-3	11-130 293-25	11-5	11-132 238-15	8-3
11-039 225-15	3-3	11-130 170-15	15-8	11-130 296-15	15-5	11-132 286-15	7-1
11-039 240-15	3-22	11-130 173-15	3-18, 3-23, 3-24, 6-3, 8-6, 8-7, 15-16, 15-20	11-130 299-25	10-10	11-132 292-25	6-3, 8-6, 8-7
11-039 306-15	3-18	11-130 176-15	3-11, 10-15, 15-5, 15-8, 15-9, 15-14, 15-17	11-130 305-15	8-2, 8-5	11-172 127-25	3-4
11-039 318-15	8-5	11-130 176-25	15-19	11-130 311-15	15-5	11-173 096-25	3-10
11-039 354-15	10-12	11-130 179-15	3-15, 6-2, 7-5, 10-15, 15-2, 15-3, 15-10, 15-13	11-130 323-15	5-2	11-173 171-15	8-1, 8-5
11-039 378-15	10-2	11-130 191-15	7-5, 15-19, 15-20	11-130 332-15	7-3	11-173 171-25	10-8, 10-10
11-039 459-15	6-5, 6-6	11-130 203-15	8-1	11-130 353-15	10-4	11-173 177-15	3-2
11-039 749-15	3-1	11-130 206-15	15-8, 15-19	11-130 359-15	10-4	11-173 222-25	10-4
11-105 275-25	8-5	11-130 209-15	15-8	11-130 365-15	10-1, 15-5	11-174 086-15	3-3
11-106 923-25	3-4	11-130 224-15	3-5, 3-16, 3-22, 5-2, 15-13	11-130 371-15	10-7	11-174 176-15	3-4
11-108 093-25	10-12	11-130 224-25	11-3	11-130 377-15	7-3, 8-1, 8-6, 8-7, 15-3	11-178 166-25	10-12
11-108 099-25	10-4, 10-5, 10-13	11-130 227-15	6-2, 7-1, 7-5, 15-15	11-130 383-15	8-1	11-180 169-25	3-1
11-108 108-15	3-10, 15-13	11-130 227-25	11-3, 11-4	11-130 389-15	5-2	11-210 038-15	3-19
11-108 120-15	15-4	11-130 233-15	3-1, 5-2, 6-1, 6-2, 6-4, 7-1, 7-6, 8-2, 8-6, 8-7, 10-15	11-130 395-15	7-5	11-210 044-25	3-3
11-108 171-15	3-18	11-130 239-15	3-1, 12-2	11-130 452-15	5-1, 6-5, 6-6, 15-2, 15-3	11-210 078-15	3-19
11-108 174-15	3-16, 15-16	11-130 239-25	11-2, 11-4	11-130 458-15	8-5	11-210 088-25	6-2, 8-6, 8-7
11-108 177-25	10-4, 10-8, 11-1	11-130 245-15	4-1, 6-2, 10-15	11-130 461-15	6-1, 6-4	11-210 165-15	3-4, 10-10
11-108 192-15	3-18	11-130 251-15	3-9, 3-22	11-130 464-15	6-1, 6-4, 6-5, 6-6, 7-1, 8-1	11-210 165-25	3-16
11-108 213-15	9-1, 9-3	11-130 257-25	9-5	11-130 482-15	7-3	11-210 168-15	3-17
11-108 219-15	3-20	11-130 281-15	3-4	11-130 533-15	10-1	11-210 168-25	3-6
11-108 225-15	3-1	11-130 284-15	3-23, 15-7	11-130 557-15	8-1	11-210 169-15	3-12, 3-20
11-108 228-25	11-1	11-130 284-25	10-8	11-130 563-15	7-3	11-210 169-25	10-6
11-108 234-15	3-12	11-130 287-15	3-1, 3-9, 3-19, 5-1, 7-6, 15-18	11-130 719-15	7-3, 7-5	11-210 174-15	3-18
11-108 255-15	3-7	11-130 287-25	10-7	11-130 903-15	3-12	11-210 210-15	3-18
11-108 846-15	3-8	11-130 287-25	10-7	11-130 905-15	3-11	11-225 094-15	6-2
11-180 169-25	3-4	11-132 169-15	3-4	11-130 906-15	3-9, 10-15	11-225 172-15	3-20, 15-14, 15-18
11-130 089-15	3-4	11-132 172-15	3-19	11-132 169-15	3-4	11-225 175-15	3-21
11-130 092-15	3-18			11-132 172-15	3-19	11-225 175-25	3-15
11-130 097-15	6-2, 15-21					11-225 178-15	6-2, 15-13
11-130 101-15	6-2					11-225 184-15	3-18

No.	Seite Page Pages Página	No.	Seite Page Pages Página	No.	Seite Page Pages Página	No.	Seite Page Pages Página
11-225 196-15	7-6	11-330 304-15	15-5	12-010 240-15	10-16	12-305 264-15	5-1, 6-1, 6-4, 6-5, 6-6, 8-1, 8-5, 15-2, 15-3, 15-5
11-225 220-15	7-3	11-330 352-15	3-1	12-024 121-15	10-16, 15-11	12-305 314-15	5-1, 15-7
11-225 223-25	11-5	11-330 364-15	6-1, 6-4	12-024 151-15	7-6, 15-20	12-315 060-15	3-18
11-225 226-15	8-6, 15-10	11-330 370-15	8-1	12-024 171-15	7-6, 8-1, 10-15, 12-2	12-315 090-25	3-4
11-225 232-15	3-8, 5-2 6-2	11-330 952-15	3-5, 3-6, 3-13, 3-16, 3-21	12-024 171-25	3-22, 3-25, 11-3, 11-4	12-316 220-15	8-2
11-225 238-15	6-1, 6-4, 11-5	11-330 955-15	3-19, 10-3	12-024 191-15	3-17, 6-5, 6-6, 8-2, 8-5, 10-15, 12-2, 15-5, 15-13, 15-15	12-318 220-05	3-8
11-225 283-15	15-18	11-330 960-15	3-2, 3-5, 3-19, 3-21	12-024 191-25	3-6	12-335 131-15	15-4
11-225 292-15	15-18	11-330 964-15	3-5, 3-18 3-21	12-024 211-15	5-1, 8-1, 15-5	12-335 151-15	6-3, 8-6, 8-7, 15-10
11-225 298-15	8-2	11-335 085-15	15-14	12-024 231-15	3-11, 6-5, 6-6, 15-5	12-335 171-15	4-1
11-225 304-15	8-1	11-335 217-15	3-5, 6-1, 6-4	12-024 251-15	5-1, 15-7	12-335 191-15	8-5
11-225 358-15	5-1, 6-2	11-335 280-15	3-3	12-024 291-15	3-1, 6-5, 6-6	12-335 210-15	10-2
11-225 364-15	8-2	11-335 902-15	3-5, 3-21	12-072 152-15	3-4	12-360 061-05	3-19
11-225 457-15	6-5, 6-6	11-340 382-15	3-24	12-105 190-25	11-1	12-360 124-05	3-25
11-225 902-15	3-8	11-341 166-15	3-19	12-305 084-15	6-2, 10-16, 15-3, 15-11, 15-21	12-360 141-05	7-1
11-225 904-05	10-1	11-341 169-15	6-2, 6-5, 6-6	12-305 084-25	15-18	12-360 143-05	7-1
11-250 084-25	3-6	11-341 217-15	3-8	12-305 114-05	3-18	12-360 181-05	8-3
11-314 277-15	11-1	11-341 901-15	3-17	12-305 114-15	6-2, 7-6, 10-12, 10-15, 15-5, 15-8, 15-9, 15-14, 15-16, 15-17, 15-19, 15-20	12-360 184-05	8-3
11-314 280-15	3-2	11-341 902-15	3-5	12-305 144-15	10-8, 10-10, 15-19	12-380 170-25	6-3, 8-6, 8-7
11-317 949-15	3-3	11-341 905-15	3-5, 3-18, 3-19, 3-21	12-305 144-25	6-2, 7-1, 8-2, 8-6, 12-2, 15-15	12-499 150-45	10-15, 15-20
11-317 950-15	3-18	11-460 193-15	10-15	12-305 174-15	9-5, 11-2, 11-3, 11-4	12-499 170-45	6-2, 7-6, 8-7
11-317 971-15	3-8	11-462 154-55	15-21	12-305 174-25	3-17, 5-2, 7-6, 8-2, 8-3, 15-5, 15-6	12-499 190-45	5-2, 7-3, 7-5, 10-15, 15-5
11-330 082-15	10-16	11-472 193-55	4-1	12-305 221-15	10-1	12-499 230-45	6-1, 6-4, 6-5, 6-6, 7-3, 8-1, 15-2, 15-3
11-330 166-15	3-3, 3-7 3-12, 3-23, 8-4	11-550 223-15	11-1, 11-5	12-305 224-15	5-1, 5-2, 8-6, 8-7 10-4, 10-7 15-5	12-499 250-45	8-1
11-330 169-15	3-4, 7-1	11-706 169-05	3-3	12-510 170-25	10-10	12-499 290-45	7-3
11-330 175-15	7-1	11-724 160-55	10-12	12-512 220-05	10-10	12-505 171-15	7-5
11-330 217-15	3-7, 3-15, 3-16, 3-19	11-724 907-55	11-4	12-517 250-45	6-1, 6-4	12-510 170-25	10-10
11-330 220-15	3-3, 3-7 3-17, 7-1	12-005 154-25	3-4	12-610 170-45	3-19	12-512 220-05	10-10
11-330 244-15	8-1	12-005 171-15	3-11, 3-18			12-517 250-45	6-1, 6-4
11-330 277-15	3-1, 3-13, 3-22	12-005 196-15	3-9			12-610 170-45	3-19
11-330 280-15	3-3, 5-2, 7-3, 8-4	12-005 215-15	3-24, 10-10, 10-12				
11-330 283-15	3-1						
11-330 286-15	7-1						

No.	Seite Page Pages Página	No.	Seite Page Pages Página	No.	Seite Page Pages Página	No.	Seite Page Pages Página
12-610 200-45	3-19	14-016 150-01	3-5	15-032 002-45	9-6	24-118 231-54	10-4
12-610 210-45	3-3, 6-1, 6-4	14-016 151-91	3-5, 3-19	15-032 006-45	3-22, 15-15	24-162 253-44	10-3
12-610 250-45	6-2	14-018 594-01	7-1	15-120 707-05	3-19	25-161 801-52	3-7, 3-20
12-610 270-45	15-5	14-018 613-01	3-21	15-120 902-05	3-19	25-161 805-04	9-6
12-610 280-45	3-1	14-018 614-91	3-18, 3-21	15-120 916-05	3-19	25-308 820-30	3-2, 3-4, 3-9, 3-11, 3-15, 15-9, 15-13, 15-15, 15-16, 15-19
12-610 310-45	3-3	14-018 640-01	8-2, 8-3	15-125 049-05	3-20	25-308 820-40	3-14, 8-4, 9-1, 9-2, 9-3, 9-4, 9-5, 10-16, 15-12, 15-16, 15-17, 15-19
12-610 330-45	8-3	14-018 644-91	3-5	15-711 050-51	3-12		9-1, 9-5
12-610 570-45	15-2, 15-3	14-026 122-01	3-19	16-040 010-11	3-18	25-308 820-60	9-1, 9-5
12-640 130-55	3-4, 3-6, 3-18	14-031 081-01	6-2	16-041 035-41	3-11	25-405 604-11	15-14
12-640 170-55	3-12	14-031 151-01	6-1, 6-4	16-042 903-01	7-1	25-405 604-12	15-14
12-660 430-45	6-1, 6-4	14-215 013-13	3-12	16-047 020-15	11-3, 15-13	25-405 604-33	15-14
12-660 520-45	6-5, 6-6, 8-1	14-215 013-23	3-3, 3-16	16-047 131-55	3-25	25-901 610-03	10-3
12-660 550-45	6-1, 6-4, 8-2, 8-3, 15-5	14-215 022-33	3-8, 3-19	16-049 020-11	11-3, 15-13	26-536 301-09	3-20
12-664 290-45	15-10	14-215 028-33	3-17	16-409 970-05	3-5	26-536 303-09	3-18
12-710 250-12	11-1	14-215 073-13	3-13	16-409 971-05	3-13	28-011 201-44	14-1
12-710 270-12	3-3	14-215 091-13	3-3	16-414 127-05	3-21	28-011 202-05	14-1
13-030 530-05	3-23	14-215 124-13	3-17	16-920 007-15	6-5, 6-6	28-011 202-10	14-1
13-030 635-05	3-1	14-215 166-23	3-3	17-518 010-51	9-6	28-011 202-43	14-1
13-030 641-05	3-1	14-215 199-33	3-17	18-277 011-91	8-4	28-011 202-47	14-1
13-033 004-05	3-18	14-218 050-01	3-8, 6-1, 6-4	18-278 001-91	3-14	28-011 200-42	15-14
13-033 109-05	3-4	14-218 080-01	3-3	18-278 005-91	3-9, 3-11	29-013 660-01	15-14
13-033 307-05	15-5	14-218 090-01	3-8, 6-2	18-372 001-91	3-14, 8-4, 9-2, 9-4	40-754 701-00	12-1
13-033 400-05	6-1, 6-4	14-246 122-01	15-13	18-372 004-91	9-5	49-031 450-02	10-16
13-033 490-05	6-5, 6-6	14-310 240-01	15-2, 15-3	18-372 008-91	8-4, 15-16, 15-17	70-163 151-11	10-4
13-033 544-05	8-4	14-602 901-01	3-6	18-373 011-91	3-9	70-371 500-02	7-6
13-033 568-05	3-7	14-650 251-05	3-21	18-378 001-91	8-4, 8-5	71-110 003-07	10-4
13-052 046-55	3-19	14-680 030-15	3-21	18-378 004-91	9-5	71-120 005-32	7-6
14-010 665-01	15-5	14-680 420-15	3-21	18-378 008-91	3-18, 15-8	71-120 006-32	3-10, 15-3, 15-13
14-012 562-01/001	3-19	14-731 451-05	7-1	18-379 004-91	9-5	71-130 004-39	10-3
14-016 101-91	3-21	14-731 915-05	6-5, 6-6	18-381 002-91	9-6	71-130 004-40	10-3
14-016 103-01	3-21	14-757 131-01	6-5, 6-6, 8-1, 8-5	24-101 220-54	7-6, 10-2		
14-016 120-01	6-1, 6-4	15-032 001-45	3-9, 3-11, 3-14	24-101 230-64	10-5		

No.	Seite Page Pages Página	No.	Seite Page Pages Página	No.	Seite Page Pages Página	No.	Seite Page Pages Página
71-130 005-52	6-2, 6-6	71-523 555-34	10-2	91-029 007-91	12-1	91-118 703-01	3-18
71-130 006-17	15-21	71-590 007-11	10-10	91-029 946-91	12-1	91-118 704-05	3-18
71-140 000-41	3-25	71-710 000-82	10-10	91-031 888-15	10-15	91-118 707-92	3-18
71-150 000-69	10-10	71-710 000-83	3-10	91-056 192-25	3-4, 3-6	91-118 709-15	3-18
71-160 001-39	10-5, 10-13	71-750 002-19	10-1	91-056 193-25	3-4, 3-6	91-118 711-05	3-18, 3-19
71-160 001-40	15-5	71-750 002-21	10-7	91-056 578-91	3-6, 12-1	91-118 724-91	3-18
71-160 001-65	10-15	71-750 002-47	10-8	91-056 760-05	3-4	91-118 726-12	3-18
71-160 003-37	10-15, 15-5	71-760 004-99	10-4	91-059 483-04/001	3-16	91-118 762-05	3-19
71-160 003-38	10-5, 10-13	71-770 000-60	10-4	91-059 483-04/002	3-16	91-118 787-15	3-19
71-160 003-80	10-4, 10-13	71-850 001-34	15-19	91-059 483-04/003	3-16	91-118 881-05	3-16
71-160 008-14	10-3	71-890 000-09	15-1	91-059 483-04/004	3-16	91-118 884-45	3-16
71-190 000-60	10-10	71-910 000-34	10-13	91-059 483-04/005	3-16	91-118 887-05	3-16
71-190 001-18	10-10	71-910 000-49	10-6	91-059 954-04/001	3-16	91-118 889-92	3-16
71-190 002-13	10-10	71-910 000-50	10-13	91-059 954-04/002	3-16	91-118 893-92	3-17
71-210 002-21	10-10	71-910 000-52	10-15	91-059 954-04/003	3-16	91-118 898-05	3-17
71-210 002-40	10-10	91-000 219-15	3-19	91-069 709-12	3-8	91-118 940-05	3-6
71-210 002-50	10-10	91-000 390-05	3-19	91-094 196-91	15-1	91-119 013-92	3-3
71-210 002-52	10-10	91-000 529-15	3-19	91-094 520-73/003	15-1	91-119 015-15	3-3
71-370 001-31	6-6	91-000 928-15	3-19	91-094 639-73/002	15-1	91-119 049-05	3-3
71-370 001-36	15-16	91-002 065-05	3-4	91-100 281-25	3-6	91-119 704-91	3-5
71-370 001-58	7-6, 10-2	91-002 262-25	3-4	91-100 355-05	3-3	91-119 705-12	3-5
71-370 001-59	10-6, 10-15, 15-5	91-006 525-05	3-2	91-105 447-25	3-4	91-119 763-05	3-3
71-370 001-75	10-6	91-006 526-05	3-2	91-118 045-91	3-16	91-123 778-12	3-13
71-370 001-77	10-2	91-010 183-05	3-4	91-118 099-91/001	3-6	91-129 153-91	12-1
71-370 002-66	15-9	91-011 909-05	6-3, 8-6, 8-7	91-118 154-90	3-18	91-129 668-25	12-2
71-370 003-01	10-2	91-012 753-05	3-21	91-118 430-25	3-4	91-129 669-75/698	12-2
71-370 003-95	10-4, 10-8	91-018 293-05	3-19	91-118 518-05	3-3	91-129 670-45	12-2
71-370 003-96	10-4, 10-8	91-018 480-05	3-19, 12-1	91-118 570-92	3-5	91-129 671-05	12-2
71-480 000-12	10-10	91-020 086-15	3-18	91-118 600-91	3-17	91-129 783-71/895	12-2
71-520 005-17	10-7	91-022 116-05	7-6	91-118 681-05	3-6	91-129 785-05	12-2
71-520 005-19	7-1	91-024 554-05	7-6	91-118 683-05	3-6	91-129 917-91	14-1
71-520 005-20	15-5	91-027 631-91	12-1	91-118 685-05	3-6	91-129 919-91	14-1

No.	Seite Page Pages Página	No.	Seite Page Pages Página	No.	Seite Page Pages Página	No.	Seite Page Pages Página
91-129920-91	14-1	91-166559-25	3-4	91-176198-05	3-3	91-266359-05	3-18
91-140199-02	3-19	91-166589-05	3-7	91-176199-92	3-3	91-266381-05	3-18
91-140239-05	3-18	91-166827-05	3-19	91-176204-05	3-3	91-266397-01	3-6
91-140676-05	3-19	91-166828-05	3-19	91-176302-05	3-3	91-266411-25	3-4
91-140945-05	3-19	91-166889-05	3-4	91-176309-05	3-3	91-266414-05	3-4
91-150656-05	3-16	91-166915-05	3-2	91-176315-05	3-3	91-266424-91	3-19
91-162526-05	3-21	91-168081-05	3-12	91-176324-25	3-4	91-266428-11	3-18
91-164443-12	3-16	91-168194-71/698	3-4	91-176329-05	3-4	91-266436-91	3-4
91-164902-91	3-3	91-168341-07	3-1	91-176332-25	3-4	91-266448-12	3-19
91-164928-91	3-3	91-169132-15	3-17	91-176337-15	3-4	91-266456-91	3-4
91-166034-01	3-2	91-169556-05	3-12	91-176373-21	3-4	91-266479-91	3-21
91-166037-25	3-2	91-170228-91	3-5	91-176378-05	3-4	91-266482-05	3-21
91-166148-72/951	3-17	91-170229-11	3-5	91-176431-05	3-4	91-266483-05	3-21
91-166352-05	3-19	91-170811-92	3-21	91-176438-05	3-19	91-266484-05	3-21
91-166376-91	3-19	91-171042-05	3-6	91-176464-05	3-4	91-266504-91	3-19
91-166377-05	3-19	91-171049-05	3-6	91-186659-05	3-18	91-266505-91	3-19
91-166378-05	3-19	91-171875-12	3-8	91-188163-15	3-18	91-266545-91	3-3
91-166381-05	3-18	91-172676-05	3-13	91-188539-02	3-19	91-266651-05	3-3
91-166382-05	3-18	91-172778-05	3-13	91-229069-75/895	12-2	91-290112-91	10-7
91-166383-15	3-18	91-173085-05	3-17	91-266037-05	3-4	91-290319-45	10-10
91-166384-05	3-18	91-173572-05	3-19	91-266129-05	3-19	91-290327-91	10-4
91-166385-15	3-18	91-173886-05	3-2	91-266132-05	3-19	91-290577-91	10-7
91-166388-05	3-19	91-173911-05	3-18	91-266136-05	3-19	91-291133-91	3-4
91-166390-92	3-19	91-173914-05	3-19	91-266138-91	3-18	91-291362-93/001	10-12
91-166391-15	3-19	91-173915-92	3-19	91-266288-15	3-18	91-291479-91	10-7
91-166452-21	3-6	91-173972-05	3-19	91-266298-05	3-18	91-291480-91	10-7
91-166493-05	3-3	91-173973-15	3-19	91-266299-91	3-18	91-291482-91	10-7
91-166520-05	3-3	91-174155-12	3-19	91-266316-91	3-18	91-291483-91	10-7
91-166521-05	3-3	91-174783-05	3-6	91-266335-01	3-3	91-291484-91	10-14
91-166529-05	3-8	91-174879-05	3-6	91-266340-05	3-20	91-291485-91	10-6
91-166531-05	3-8	91-176076-91	3-19	91-266352-75/895	3-1	91-291487-91	10-10
91-166532-05	3-8	91-176094-05	3-19	91-266353-05	3-4	91-291488-91	7-1

No.	Seite Page Pages Página	No.	Seite Page Pages Página	No.	Seite Page Pages Página	No.	Seite Page Pages Página
91-291 489-91	10 - 10	91-291 550-05	10 - 10	91-291 810-91	10 - 4	95-215 040-13/923	7 - 3
91-291 490-91	10 - 7	91-291 551-05	10 - 12	91-291 811-91	10 - 4	95-215 040-14/132	7 - 3
91-291 491-91	10 - 8	91-291 552-05	10 - 12	91-700 018-15	3 - 17	95-215 040-14/133	7 - 3
91-291 492-91	10 - 10	91-291 553-05	10 - 12	91-700 249-15	3 - 18	95-215 040-14/134	7 - 3
91-291 493-91	10 - 8	91-291 554-05	10 - 8	91-700 335-25	6 - 6, 10 - 16, 15 - 14	95-215 040-14/135	7 - 5
91-291 494-91	10 - 4	91-291 555-91	3 - 14	91-700 412-25	3 - 4	95-215 040-14/136	7 - 3
91-291 496-91	10 - 7	91-291 556-91	3 - 14	91-700 510-15	3 - 5	95-215 040-14/138	7 - 5
91-291 497-91	10 - 4	91-291 557-91	15 - 21	91-700 689-15	3 - 16	95-215 040-14/141	7 - 3
91-291 498-91	10 - 10	91-291 566-91	10 - 13	91-700 785-15	3 - 2	95-215 040-14/143	7 - 3
91-291 499-91	10 - 8	91-291 582-91	15 - 3	91-701 522-25	3 - 4	95-215 040-14/145	7 - 3
91-291 500-91	10 - 13	91-291 583-91	15 - 5	95-215 000-02/255	7 - 3	95-215 040-14/146	7 - 3
91-291 501-91	3 - 25	91-291 586-93/001	10 - 10	95-215 000-03/413	7 - 5	95-215 040-14/148	7 - 3
91-291 502-91	3 - 23	91-291 589-91	10 - 8	95-215 000-03/636	8 - 1	95-215 040-14/161	7 - 5
91-291 503-91	10 - 12	91-291 592-91	3 - 15	95-215 000-03/637	8 - 1	95-215 040-14/175	8 - 1
91-291 504-91	10 - 14	91-291 593-91	7 - 6	95-215 000-03/638	8 - 5	95-215 040-14/177	8 - 4
91-291 505-91	10 - 1	91-291 594-91	10 - 2	95-215 000-03/639	8 - 4	95-215 040-15/128	8 - 6
91-291 506-91	10 - 4	91-291 595-71/895	10 - 3	95-215 000-03/992	7 - 3	95-215 040-15/131	7 - 5
91-291 507-91	10 - 5	91-291 597-91	10 - 13	95-215 040-03/316	7 - 3	95-215 040-15/132	8 - 5
91-291 508-91	10 - 5	91-291 598-90	15 - 21	95-215 040-04/026	8 - 1	95-215 040-15/133	8 - 3
91-291 509-91	10 - 13	91-291 630-91	6 - 2	95-215 040-04/670	8 - 2	95-215 040-15/136	8 - 6
91-291 510-91	10 - 5	91-291 631-91	6 - 2	95-215 040-04/671	6 - 3, 8 - 6, 8 - 7	95-215 040-15/137	8 - 6
91-291 511-91	10 - 10	91-291 632-91	6 - 2	95-215 040-08/763	6 - 3, 8 - 6, 8 - 7	95-215 040-15/141	8 - 1
91-291 512-91	9 - 6	91-291 641-91	3 - 10	95-215 040-08/768	8 - 2	95-215 040-15/143	8 - 3
91-291-514-91	10 - 12	91-291 647-91	10 - 5	95-215 040-12/561	7 - 3	95-215 040-15/145	8 - 2
91-291 515-91	10 - 10	91-291 648-91	15 - 19	95-215 040-12/569	7 - 5	95-215 040-15/147	8 - 7
91-291 516-05	10 - 10	91-291 650-91	10 - 5	95-215 040-13/534	7 - 5	95-215 040-15/149	8 - 6
91-291 517-05	10 - 10	91-291 676-91	15 - 13	95-215 040-13/535	7 - 3	95-215 040-15/128	8 - 6
91-291 518-91	6 - 6	91-291 702-91	15 - 15	95-215 040-13/591	7 - 3	95-215 040-15/323	6 - 3, 8 - 6, 8 - 7
91-291 519-91	6 - 6	91-291 704-91	15 - 16	95-215 040-13/877	7 - 3	95-215 040-15/324	8 - 5
91-291 520-91	7 - 1	91-291 705-01	15 - 21	95-215 040-13/878	7 - 3	95-215 040-15/325	8 - 1
91-291 521-91	7 - 1	91-291 707-91	10 - 13	95-215 040-13/880	7 - 5	95-215 040-15/326	8 - 2
91-291 549-05	10 - 10	91-291 751-91	10 - 8	95-215 040-13/921	7 - 3	95-215 040-15/357	8 - 1

No.	Seite Page Pages Página	No.	Seite Page Pages Página	No.	Seite Page Pages Página	No.	Seite Page Pages Página
95-215 040-15/358	8-2	95-753 595-05	6-5, 6-6	95-775 353-75/895	7-1	95-775 469-75/895	3-1
95-215 040-15/359	8-2	95-753 596-15	6-5, 6-6	95-775 357-15	13-1, 15-11 15-18	95-775 470-05	3-22
95-215 040-15/381	6-6	95-753 597-05	6-5, 6-6	95-775 369-01	15-18	95-775 471-05	3-22
95-215 040-15/383	8-4	95-753 599-11	5-1	95-775 381-91	8-2	95-775 472-72/893	3-7
95-215 040-15/384	8-4	95-753 606-05	6-2	95-775 382-71/895	8-3	95-775 473-90	3-5
95-215 040-15/386	6-6	95-753 607-05	6-2	95-775 383-71/895	8-1	95-775 476-05	3-7
95-215 070-00/236	8-5	95-753 608-47	15-18	95-775 394-15	3-20	95-775 477-91	3-22
95-215 070-05/901	7-3	95-753 621-05	6-1	95-775 402-75/895	3-1	95-775 482-12	3-16
95-215 070-42/609	8-4	95-753 637-05	6-1, 6-4	95-775 403-75/895	3-1	95-775 483-05	3-17
95-215 080-08/970	8-2	95-753 638-05	6-1, 6-4	95-775 405-71/895	3-1	95-775 484-05	3-17
95-215 080-14/925	7-5	95-753 646-05	6-1, 6-4	95-775 414-92	3-12	95-775 485-92	3-17
95-215 080-17/604	7-5	95-753 650-91	6-1, 6-4	95-775 416-92	3-11	95-775 486-05	3-16
95-215 080-17/605	7-5	95-753 651-91	6-1, 6-4	95-775 421-91	3-5	95-775 487-05	3-21
95-215 080-18/007	8-1, 8-4	95-753 696-05	6-2	95-775 422-91	3-5	95-775 488-05	3-19
95-215 080-18/008	7-3, 8-1, 8-2	95-753 907-75/895	15-17	95-775 424-91	3-3	95-775 489-05	3-11
95-215 080-18/102	7-5	95-775 229-25	15-8	95-775 425-01	3-3	95-775 490-05	3-13
95-215 080-34/704	8-2	95-775 258-71/895	8-7	95-775 427-05	3-1	95-775 491-15	3-1
95-215 080-35/001	8-2	95-775 259-71/895	8-6	95-775 428-05	3-22	95-775 492-91	3-16
95-215 080-35/201	8-2	95-775 311-15	7-1	95-775 429-92	3-2	95-775 493-71/895	3-17
95-215 080-35/202	8-2	95-775 320-91	3-15	95-775 431-91	3-22	95-775 494-91	3-18
95-215 080-35/203	8-2	95-775 322-05	3-15	95-775 433-05	3-9	95-775 495-05	3-7
95-215 080-35/301	8-2	95-775 324-05	6-2	95-775 434-15	3-9	95-775 497-15	3-24
95-560 274-75/940	10-5	95-775 327-05	6-2, 8-7	95-775 435-92	3-8	95-775 499-15	3-22
95-633 660-91	9-6	95-775 328-05	15-14	95-775 436-15	3-8	95-775 500-05	3-9
95-665 735-91	14-2	95-775 329-90	6-3, 8-6, 8-7	95-775 437-15	3-22	95-775 501-75/893	6-5, 6-6
95-714 813-05	11-1	95-775 340-71/895	7-1	95-775 438-05	3-22	95-775 502-71/893	5-1
95-730 065-15	15-12	95-775 346-75/895	7-1	95-775 441-15	3-1	95-775 504-05	6-5, 6-6
95-753 342-15	10-3	95-775 347-15	7-1	95-775 446-12	3-21	95-775 505-75/893	6-5, 6-6
95-753 577-05	6-2	95-775 349-15	7-1	95-775 447-91	3-14	95-775 506-75/893	6-5, 6-6
95-753 578-75/893	6-1, 6-4	95-775 350-91	9-1	95-775 449-75/893	3-1	95-775 509-05	15-2, 15-3
95-753 593-15	6-2	95-775 351-91	9-3	95-775 467-92	3-1	95-775 511-15	15-2, 15-3
95-753 594-15	6-2	95-775 352-15	7-1	95-775 468-05	3-1	95-775 512-05	6-5, 6-6

No.	Seite Page Pages Página	No.	Seite Page Pages Página	No.	Seite Page Pages Página	No.	Seite Page Pages Página
95-775 513-05	6-1, 6-4	95-775 572-05	6-1	95-775 688-25	11-1	95-775 884-05	15-14
95-775 514-05	15-2, 15-3	95-775 577-15	15-10	95-775 690-05	4-1	95-775 885-15	15-14
95-775 516-15	15-5	95-775 578-15	15-10	95-775 695-71/895	5-1	95-775 886-15	15-14
95-775 518-05	15-2, 15-3	95-775 579-05	15-8	95-775 696-71/895	11-1	95-775 905-15	3-25
95-775 520-91	15-2, 15-3	95-775 580-04	15-9	95-775 699-75/895	11-3	95-775 908-11	3-5
95-775 525-15	15-5	95-775 581-15	5-2	95-775 701-75/893	6-5, 6-6	95-775 912-11	3-21
95-775 527-15	15-5	95-775 582-15	5-2	95-775 708-91	15-18	95-775 913-15	13-1
95-775 529-75/893	15-5	95-775 583-15	15-10	95-775 710-92	15-18	95-775 914-91	3-5
95-775 530-05	15-5	95-775 584-15	15-10	95-775 715-90	15-7	95-775 915-05	3-8
95-775 531-05	15-5	95-775 585-15	15-10	95-775 718-75/895	11-4	95-775 917-05	3-11
95-775 532-05	15-5	95-775 586-15	15-10	95-775 732-05	11-3	95-775 919-05	3-7, 3-23
95-775 533-15	6-2	95-775 589-91	15-8	95-775 733-05	11-4	95-775 921-11	3-23
95-775 534-91	5-2	95-775 592-15	15-10	95-775 735-75/895	11-1	95-775 923-71/893	3-1
95-775 535-01	6-1, 6-4	95-775 593-91	15-10	95-775 742-05	3-15	95-775 924-01	3-1
95-775 536-05	6-2	95-775 594-91	15-10	95-775 751-75/895	11-2	95-775 929-71/898	3-4
95-775 537-05	6-2	95-775 595-91	15-10	95-775 752-75/895	11-2	95-775 930-25	3-4
95-775 538-05	6-2	95-775 606-71/893	5-1	95-775 753-91	3-2	95-775 931-11	3-13
95-775 540-11	6-1, 6-4	95-775 607-71/893	5-1	95-775 757-05	15-14	95-775 934-11	3-5
95-775 541-91	6-1, 6-4	95-775 610-71/893	5-1	95-775 758-15	15-21	95-775 937-25	3-4
95-775 542-75/893	6-1, 6-4	95-775 612-15	5-1	95-775 763-04	15-9	95-775 940-01	3-20
95-775 543-71/893	6-1, 6-4	95-775 613-15	6-1, 6-4	95-775 764-71/895	5-1	95-775 941-05	3-20
95-775 544-71/893	6-1, 6-4	95-775 614-71/893	5-1	95-775 770-05	10-1	95-775 942-91	3-11
95-775 545-71/893	6-5, 6-6	95-775 620-15	6-1, 6-4	95-775 776-05	11-3	95-775 943-91	3-9
95-775 546-15	6-5, 6-6	95-775 622-71/895	7-3	95-775 777-75/895	11-2	95-775 944-91	3-4
95-775 547-05	6-2	95-775 644-71/895	7-6	95-775 791-15	5-2	95-775 945-91	3-14
95-775 548-05	6-2	95-775 658-15	6-2	95-775 792-11	5-2	95-776 015-91	15-4
95-775 549-01	6-2	95-775 664-71/893	15-3	95-775 800-91	3-4	95-776 025-05	11-1
95-775 550-05	6-2	95-775 665-75/893	15-3	95-775 823-71/895	3-7	95-776 042-91	10-1
95-775 555-75/893	5-1	95-775 666-15	15-3	95-775 851-75/893	15-6	95-776 060-15	6-5, 6-6
95-775 556-75/893	5-1	95-775 674-71/893	15-5	95-775 853-15	15-8	95-776 062-05	4-1
95-775 569-05	4-1	95-775 683-15	15-7	95-775 880-05	15-4	95-776 063-05	4-1
95-775 571-05	6-4	95-775 687-05	15-7	95-775 882-15	5-2	95-776 076-11	5-2

No.	Seite Page Pages Página	No.	Seite Page Pages Página	No.	Seite Page Pages Página	No.	Seite Page Pages Página
95-776 081-71/895	11 - 1	95-776 422-90	15 - 16	99-115 034-15	12 - 2	99-135 496-95	8-4, 9-3, 9-4, 15-12, 15-17, 15-19 10-16
95-776 082-05	11 - 5	95-776 440-05	11 - 4	99-115 187-21	12 - 1	99-135 549-91	10-16
95-776 085-05	11 - 5	95-776 430-05	15 - 13	99-115 412-91	12 - 1	99-135 556-91	9 - 5
95-776 111-05	13 - 1	95-776 431-05	15 - 13	99-115 453-91	6 - 5, 6 - 6	99-135 601-91	3 - 24
95-776 128-15	15 - 11	95-776 432-05	15 - 13	99-115 505-91	3 - 14, 9 - 2, 9 - 4	99-135 613-91	15 - 9, 15 - 19
95-776 136-05	10 - 16	95-776 434-91	15 - 13	99-133 127-91	8 - 4	99-135 617-95	8 - 4, 9 - 5, 10 - 16
95-776 137-15	10 - 16	95-776 442-01	15 - 14	99-133 283-15	3 - 17	99-135 621-91	15 - 12
95-776 149-11	8 - 5	95-776 453-91	5 - 2	99-133 753-91	15 - 15	99-135 809-91	3 - 24
95-776 187-91	10 - 16	95-776 472-11	15 - 11	99-133 920-91	3 - 20	99-135 818-05	9 - 3, 15 - 9
95-776 188-01	13 - 1	95-776 473-11	15 - 11	99-133 962-91	7 - 1	99-135 819-05	9 - 3, 15 - 9
95-776 189-15	13 - 1	95-776 505-91	3 - 12	99-134 207-05	3 - 20	99-135 835-05	15 - 16
95-776 190-05	7 - 2	95-776 506-92	3 - 12	99-134 206-05	15 - 16, 15 - 17	99-135 845-91	3 - 11
95-776 196-01	13 - 1	95-776 507-05	3 - 12	99-134 255-91	15 - 16, 15 - 17	99-135 887-75	15 - 11
95-776 207-91	12 - 1	95-776 508-05	3 - 12	99-134 256-91	15 - 12, 15 - 13, 15 - 15	99-135 911-91	15 - 8, 15 - 15
95-776 210-90	15 - 19	95-776 509-92	3 - 12	99-134 296-45	3 - 13	99-136 009-75	11 - 5
95-776 210-91	15 - 19	95-776 510-05	3 - 12	99-134 299-91	3 - 18	99-136 071-95	15 - 15
95-776 211-15	6 - 2	95-776 511-05	3 - 12	99-134 421-91	3 - 18	99-136 072-95	9 - 5
95-776 296-71/893	10 - 3	95-776 512-05	3 - 12	99-134 586-91	10 - 15, 15 - 13	99-136 205-91	8 - 4
95-776 298-71/893	10 - 3	95-776 513-05	3 - 12	99-134 594-71/893	5 - 1, 10 - 3	99-136 220-91	10 - 16
95-776 299-05	5 - 2	95-776 516-05	15 - 16	99-134 815-91	5 - 1	99-136 235-91	3 - 22
95-776 300-05	11 - 1	95-776 519-90	15 - 14	99-134 850-91	7 - 1	99-136 345-91	5 - 1
95-776 303-90	15 - 19	95-776 537-05	15 - 18	99-134 851-91	3 - 14	99-136 396-91	3 - 20
95-776 304-71/893	15 - 20	95-776 540-05	15 - 18	99-134 935-91	5 - 1, 15 - 2, 15 - 3	99-136 409-91	3 - 20
95-776 305-90	15 - 19	95-776 559-15	10 - 15	99-134 960-91	3 - 11	99-136 585-95	4 - 1, 11 - 2 11 - 5
95-776 305-91	15 - 19	95-776 560-15	10 - 15	99-135 002-95	3 - 9, 15 - 9, 15 - 13	99-136 601-91	3 - 9
95-776 327-05	11 - 5	95-776 561-15	10 - 15	99-135 066-91	3 - 4	99-136 778-91	3 - 6
95-776 328-05	11 - 1	95-776 562-05	15 - 18	99-135 108-91	3 - 20	99-136 846-91	15 - 7
95-776 351-71/893	5 - 2	95-776 563-05	15 - 18	99-135 184-91	15 - 13	99-137 005-15	15 - 14
95-776 354-71/895	10 - 3	95-776 564-05	15 - 18	99-135 233-91	3 - 11, 3 - 15, 15 - 13	99-137 077-91	3 - 14
95-776 358-05	11 - 5	95-776 566-90	15 - 17	99-135 353-91	9 - 3	99-137 079-05	3 - 1
95-776 414-11	8 - 5	96-700 175-15	3 - 11	99-135 431-91	9 - 6	99-137 085-91	6 - 2
95-776 417-15	11 - 5	96-701 212-92	3 - 11	99-135 490-91	3 - 1, 3 - 4, 3 - 9, 3 - 22, 15 - 8	99-137 086-91	6 - 5, 6 - 6

No.	Seite Page Pages Página	No.	Seite Page Pages Página	No.	Seite Page Pages Página	No.	Seite Page Pages Página
99-137 087-05	15-2, 15-3						
99-137 151-45	3-6						
99-137 152-91	7-1						
99-137 169-91	15-8						
99-137 170-91	9-6						
99-137 171-91	13-1						
99-137 172-91	8-7						
99-137 174-91	10-15						
99-137 181-91	3-14						
99-137 182-91	7-1						
99-137 185-95	3-14						
99-137 196-01	12-1						
99-137 200-05	10-15						
99-137 206-91	4-1						
99-137 229-91	15-15						
99-137 269-91	9-1, 9-3, 15-16						
99-137 270-91	9-1, 9-3, 15-19						
99-137 271-91	9-3						

PFAFF