

## 5704

## 5714

Teileliste

Parts list

Lista de piezas

零件表

## 5716

## 5742

Diese Teileliste hat für Maschinen ab nachfolgender  
Seriennummer Gültigkeit:

This parts list applies to machines from the following  
serial numbers onwards:

Esta lista de piezas tiene validez para máquinas a partir del  
número de serie siguiente:

本零件表对从下列系列号起的机器有效:

# 6001000 

Alle Informationen und Abbildungen waren zum Zeitpunkt der Druckgebung auf dem neusten Stand.

Technische Änderungen vorbehalten!

Der Nachdruck, die Vervielfältigung sowie die Übersetzung - auch auszugsweise - aus PFAFF-Teilelisten ist nur mit unserer vorherigen Zustimmung und mit der Quellenangabe gestattet.

At the time of printing, all information and illustrations contained in this document were up to date.

Subject to alteration!

The reprinting, copying or translation of PFAFF Parts lists whether in whole or in part, is only permitted with our previous permission and with written reference to the source.

Todas las informaciones e ilustraciones de este manual estaban al día en el momento de entregarse para su impresión.

¡ Salvo modificaciones técnicas!

La reimpresión, reproducción y traducción - aunque sólo sea parcial - de las listas de piezas PFAFF sólo está permitida con nuestro permiso previo e indicando la fuente.

所有信息和图片在付印时都是最新的。

保留技术更改的权力！

全部或部分翻印、复制以及翻译PFAFF-零件表必须事先经由我们同意并且注明来源。

**PFAFF Industrie Maschinen AG**

Postfach 3020

D-67653 Kaiserslautern

Königstr. 154

D-67655 Kaiserslautern

		<b>Seite</b> Page Página 页号
<b>0</b>	<b>Wichtiger Hinweis</b> ..... Important note Observación importante 重要提示	<b>0 - 1</b>
<b>1</b>	<b>Vorwort</b> ..... Foreword Notas preliminares 前言	<b>1 - 1</b>
<b>2</b>	<b>Erläuterungen der Schlüsselzeichen</b> ..... Explanation of key markings Explicaciones de los signos clave 标记说明	<b>2 - 1</b>
<b>3</b>	<b>Basismaschine</b> Basic machine Máquina básicas 基础机器	
<b>3</b>	<b>Gehäuseteile</b> ..... Housing sections Piezas del cárter 机身零件	<b>3 - 1</b>
<b>4</b>	<b>Fadenführungen und Fadenspannungen</b> ..... Thread guides and thread tensions Guiahilos y tensahilos 导线架和缝线张紧装置	<b>4 - 1</b>
<b>5</b>	<b>Nadelstangenantrieb</b> ..... Needle drive mechanism Accionamiento de la barra agujas 针杆驱动器	<b>5 - 1</b>
<b>6</b>	<b>Fadenöler</b> ..... Thread lubricator Lubricador del hilo 缝线润滑器	<b>6 - 1</b>
<b>7</b>	<b>Stoffdrückerfußaggregat</b> ..... Presser foot assembly Mecanismo del pie prensatelas 压脚装置	<b>7 - 1</b>

		Seite Page Página 页号
<b>8</b>	<b>Kurbelwellenaggregat</b> ..... Crank shaft mechanism Mecanismo de transmisión por manivela 曲轴装置	<b>8 - 1</b>
<b>9</b>	<b>Messerantrieb</b> ..... Crank shaft mechanism Mecanismo de accionamiento de la cuchilla 切刀驱动器	<b>9 - 1</b>
<b>10</b>	<b>Transportmechanismus</b> ..... Feed mechanism Mecanismo de arrastre 送料机构	<b>10 - 1</b>
<b>11</b>	<b>Nadelschutzteile</b> ..... Needle guard parts Piezas de protección de aguja 护针零件	<b>11 - 1</b>
<b>12</b>	<b>Greiferantrieb</b> ..... Looper drive mechanism Accionamiento del garfio derecho 弯针驱动器	<b>12 - 1</b>
<b>13</b>	<b>Schmierungssystem</b> ..... Lubricating system Sistema de engrase 润滑系统	<b>13 - 1</b>
<b>14</b>	<b>Teile für halbversenkte Aufstellung</b> ..... Parts for semi-submerged installation Piezas para montaje semioculto 用于半下沉安装的零件	<b>14 - 1</b>
<b>15</b>	<b>Garnrollenständer</b> ..... Reel stands Portacarretes 线轴支架	<b>15 - 1</b>
<b>16</b>	<b>Schmiermittel-Übersicht</b> ..... Overview of lubricants Tabla de lubricantes 润滑剂一览	<b>16 - 1</b>

	<b>Seite</b> Page Página 页号
<b>17</b> Index (Teilenummern / Seitenzahlen) .....17 - 1 Index (part numbers / page numbers) Index (números de pieza / números de página) 注脚(零件号/页号)	
<b>18</b> Unterklassen-Ausstattung Subclass parts Composición de las subclases 子机型-设备	
<b>18.01</b> Nähwerkzeuge (PFAFF 5704).....18 - 2 Gauge parts (PFAFF 5704) Organos de costura (PFAFF 5704) 缝纫工具	
<b>18.02</b> Nähwerkzeuge (PFAFF 5714).....18 - 6 Gauge parts (PFAFF 5714) Organos de costura (PFAFF 5714) 缝纫工具	
<b>18.03</b> Nähwerkzeuge (PFAFF 5716).....18 - 8 Gauge parts (PFAFF 5716) Organos de costura (PFAFF 5716) 缝纫工具	
<b>18.04</b> Nähwerkzeuge (PFAFF 5742).....18 - 11 Gauge parts (PFAFF 5742) Organos de costura (PFAFF 5742) 缝纫工具	

### Achtung!



Wir machen ausdrücklich darauf aufmerksam, daß Ersatz- und Zubehörteile, die nicht von uns geliefert werden, auch nicht von uns geprüft und freigegeben sind. Der Einbau und / oder die Verwendung solcher Produkte kann daher u. Umständen konstruktiv vorgegebene Eigenschaften Ihrer Maschine negativ verändern. Für Schäden, die durch die Verwendung von Nicht-Originalteilen entstehen, übernehmen wir keine Haftung!

### Caution!



We warn you expressively that spare parts and accessories that are not supplied by us are not tested and released by us. Fitting or using these products may therefore have negative influences on features that depend on the machine design. We are not liable for any damage caused by the use of non-Pfaff parts!

### ¡Atención!















Se hace observar que en el caso de piezas de recambio y accesorios que no hayan sido suministrados por nosotros, quiere decir que non han sido sometidas por nuestra parte a un control y que no se les ha dado el visto bueno. Por esta razón, el montaje y/o empleo de tales productos puede repercutir negativamente en las características previstas en su máquina. ¡Para los daños que eventualmente pudiesen presentarse al utilizar piezas no originales, no asumimos ninguna garantía!

### 注意!



我们必须明确指出，所有不是由我们供货的备件和附件都未经我们检查，也没有被我们批准使用。装入和/或使用这些产品可能在一定的情况下会对机器的设计特性造成负面改变。对由于使用非原装件所造成的损失，我们不负任何责任！

- Die Seriennummer der Maschine, für die diese Teileliste Gültigkeit hat, ist auf der Titelseite aufgeführt.
  - Alle Teile sind so abgebildet, wie sie in der Maschine funktionsmäßig zusammengehören.
  - Gestrichelt dargestellte Teile zeigen angrenzende Teile aus anderen Funktionsgruppen.
  - Im oberen Teil der Bildseiten befindet sich eine Gesamtansicht der Maschine .
  - Der Einbauort der dargestellten Teile wird durch eine gerasterte Fläche gekennzeichnet.
  - Einrahmungen auf den Bildseiten zeigen, aus welchen Einzelteilen sich die Gruppenteile zusammensetzen.
  - Die auf den Bildseiten verwendeten Schlüsselzeichen (  ;  ;  usw.) sind im Kapitel "Erläuterungen der Schlüsselzeichen" aufgelistet.
- 
- The serial number of the machine to which this parts list applies is indicated on the cover page.
  - All parts are illustrated in function groups with the parts which they function together with in the machine.
  - Parts illustrated with broken lines are parts from other function groups which border on the illustrated function group.
  - The above section of the page of illustrations contains a total view of the machine. The place for the installation of the parts pictured here is marked by the grid.
  - The framed-in sections on the illustration pages show the individual parts comprising a group.
  - The key markings used on the illustrated pages (  ;  ;  etc.) are listed in the chapter "Explanation of key markings".
- 
- El número de serie de la máquina para la cual tiene validez esta lista de piezas va indicado en la página de título.
  - Todas las piezas están ilustradas tal como aparecen en la máquina para su funcionamiento.
  - Las piezas representadas con rayitas muestran piezas colindantes de otros grupos de funciones.
  - En la parte superior de las páginas ilustradas se puede ver una vista en conjunto de la máquina.
  - El lugar de montaje de la pieza representada va caracterizada mediante una superficie reticulada.
  - Los recuadros en las páginas ilustradas indican las piezas individuales de que se componen los grupos.
  - Los signos clave (  ;  ;  etc.) empleados en las páginas con ilustraciones van listados en el capítulo "Explicaciones de los signos clave".
- 
- 适用于本零件表的机器系列号列在首页上。
  - 所有的零件都按照其在机器中的功能情况合在一起表达。
  - 用虚线表示的零件为相邻功能组中的零件。
  - 图的上部为机器全景。
  - 所示零件的安装部位用影格面表示。
  - 页上的框表示这套组件都由哪些零件所组成。
  - 图页上所使用的标记 (  ;  ;  等) 列表在“标记说明”中。

- Unterklassenabhängig, Teilenummer siehe Unterklassen-Ausstattung.**  
Subclas-dependent, for part number see subclass parts listing.  
Dependientes de la subclase, para el número de pieza véase "Dotación de subclases".  
取决于子机型，零件号见子机型设备。
- 3** **Geklebt**  
Part cemented  
Pieza pegada  
被粘住
- 6** **Nadeldicke und Spitzenform bei Bestellung angeben.**  
Needle size and style of point to be stated on order.  
Grosor de aguja y forma de la punta, indíquese en los pedidos.  
在订货时给出针厚和针尖型式。
- 10** **Nadelabstand**  
Needle gauge  
Distancia entre agujas  
针间距
- 40/1** **Füllen mit 28-011 201-44; Bestellnummer siehe Seite 16 - 1.**  
Top up with 28-011 201-44; for part number see page 16 - 1.  
Rellene con 28-011 201-44; para el número de pedido véase la página 16 - 1.  
注油用 28-011 201-44; 订货号见 16 - 1页。
- 40/2** **Tränken mit 28-011 201-44; Bestellnummer siehe Seite 16 - 1.**  
Grease with 28-011 201-44; for part number see page 16 - 1.  
Engrase con grasa 28-011 201-44; para el número de pedido véase la página 16 - 1.  
浸油用 28-011 201-44; 订货号见 16 - 1页。
- 40/3** **Fetten mit 28-011 202-47; Bestellnummer siehe Seite 16 - 1.**  
Grease with 28-011 202-47; for part number see page 16 - 1.  
Engrase con grasa 28-011 202-47; para el número de pedido véase la página 16 - 1.  
上脂用 28-011 202-47; 订货号见 16 - 1页。
- 96** **Länge angeben**  
State length  
Indíquese la largura  
给出长度



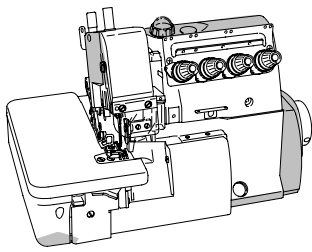

Gehäuseteile  
Housing sections  
Piezas del cárter  
机身零件

PFAFF 5704  
PFAFF 5714  
PFAFF 5716  
PFAFF 5742

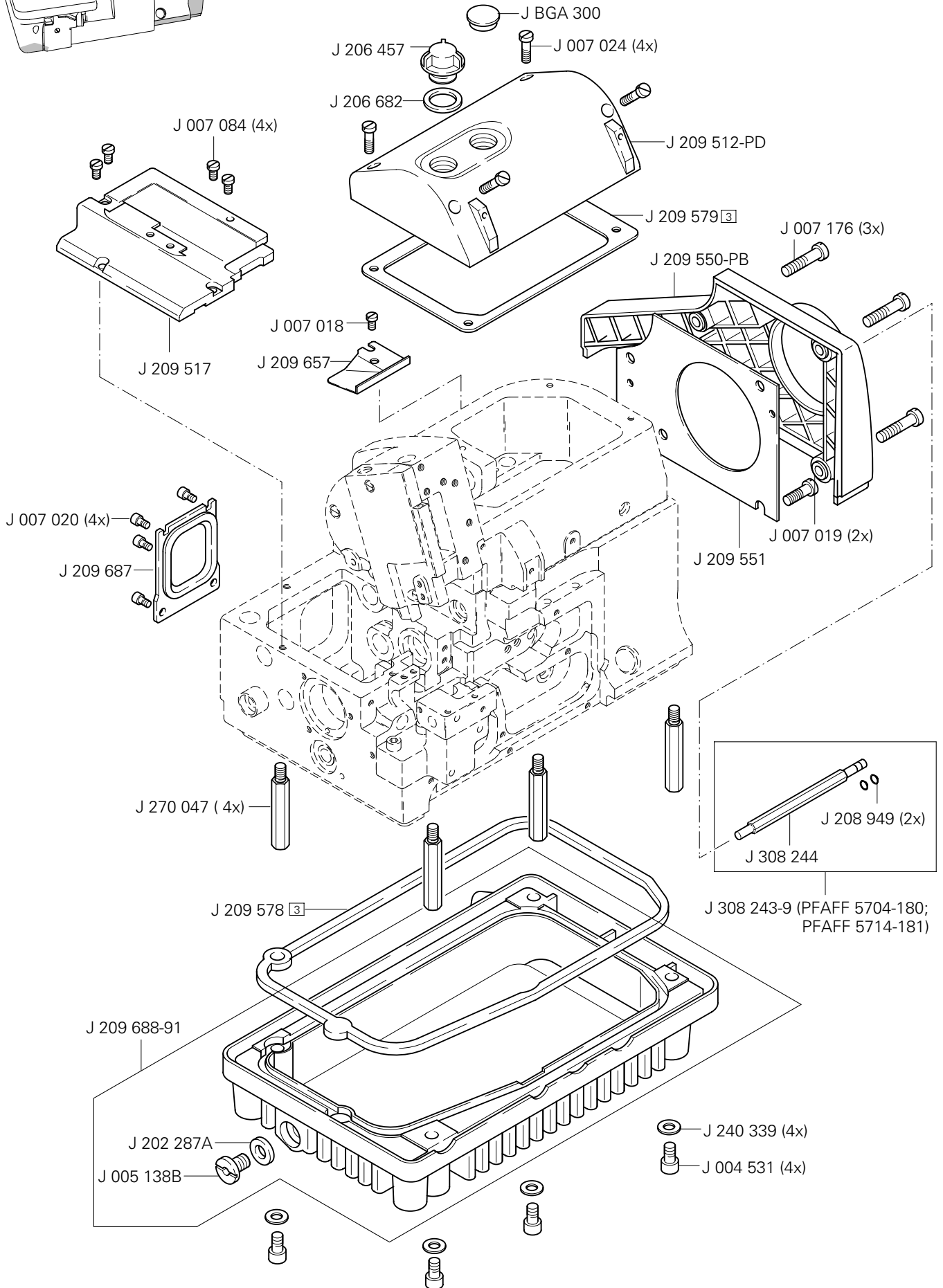

# 3

Gehäuseteile  
Housing sections  
Piezas del cárter  
机身零件

PFAFF 5704  
PFAFF 5714  
PFAFF 5716  
PFAFF 5742

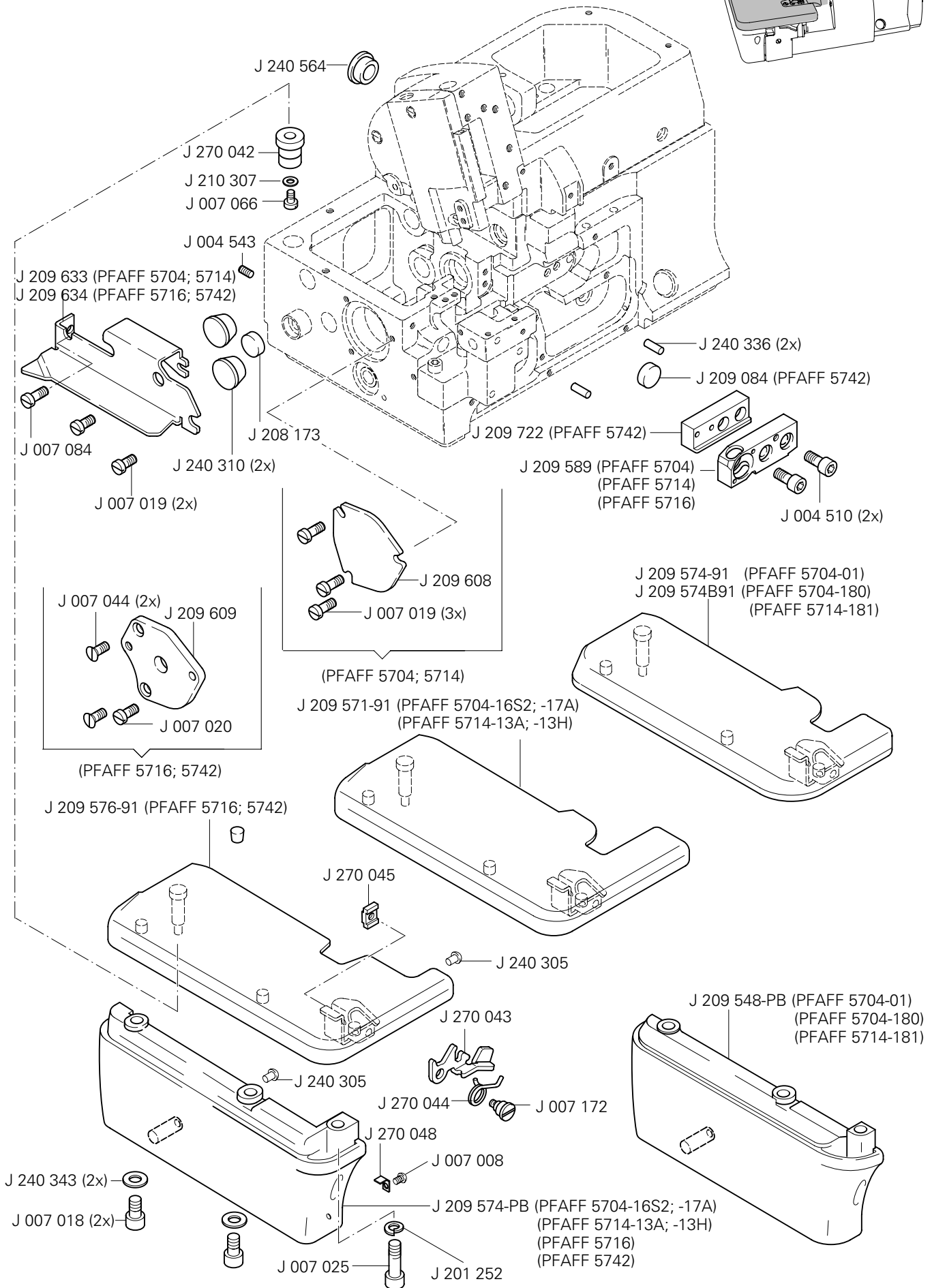
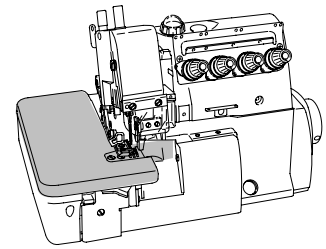

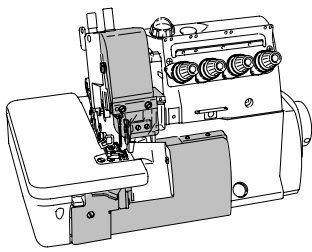

Gehäuseteile  
Housing sections  
Piezas del cárter  
机身零件

PFAFF 5704  
PFAFF 5714  
PFAFF 5716  
PFAFF 5742

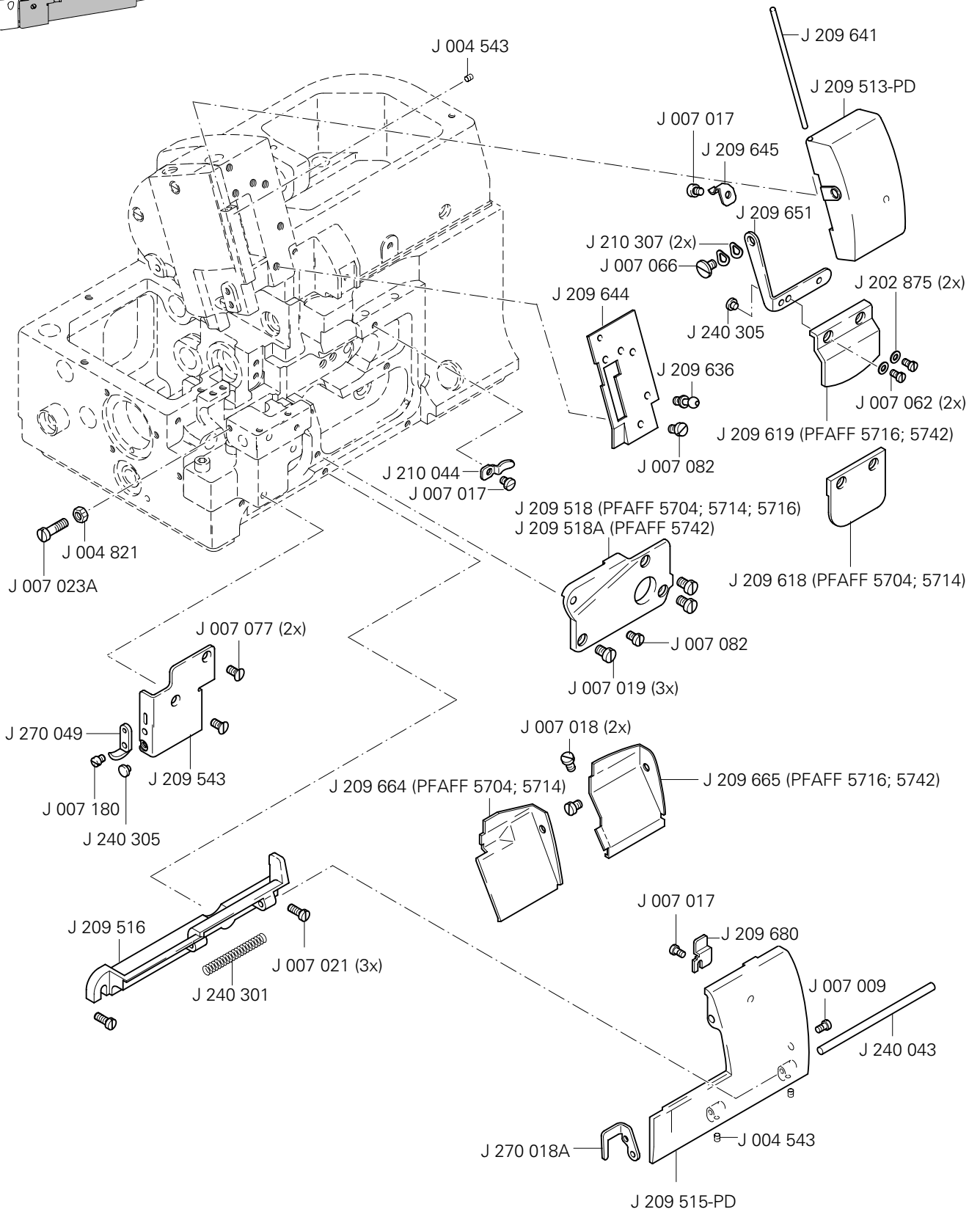

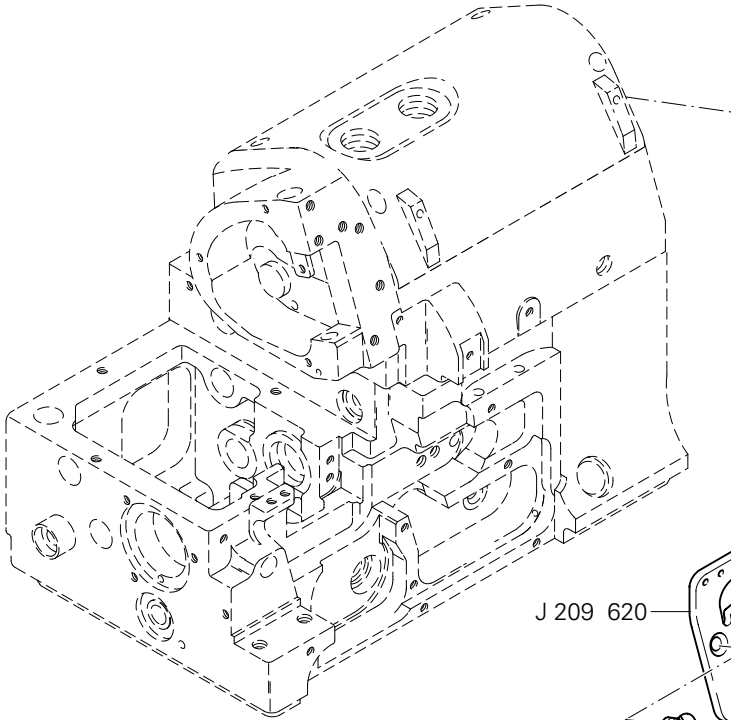
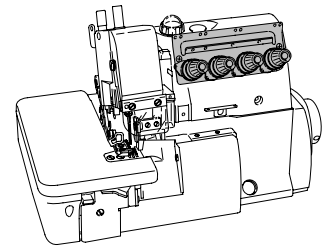



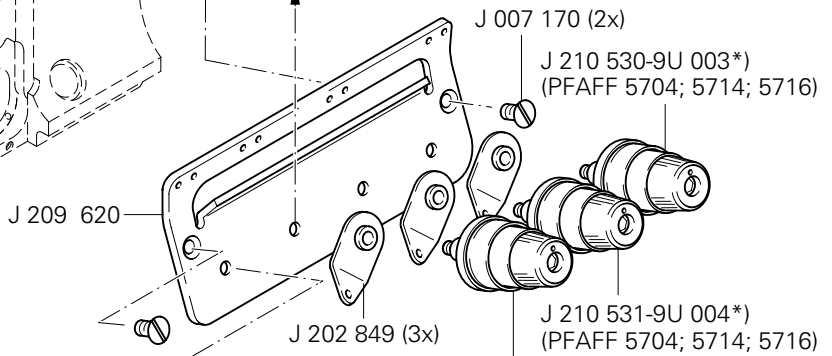

Anschluß siehe Seite 4-3  
For connection see page 4-3  
Para la conexión, véase la pag. 4-3  
接口见 4-3 页

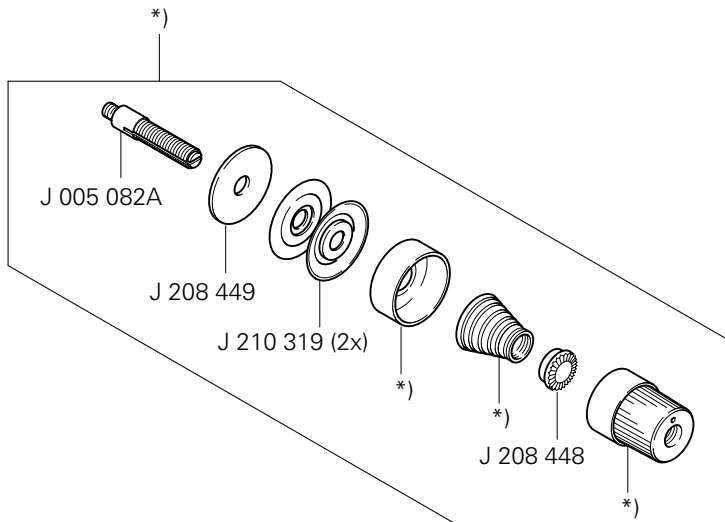
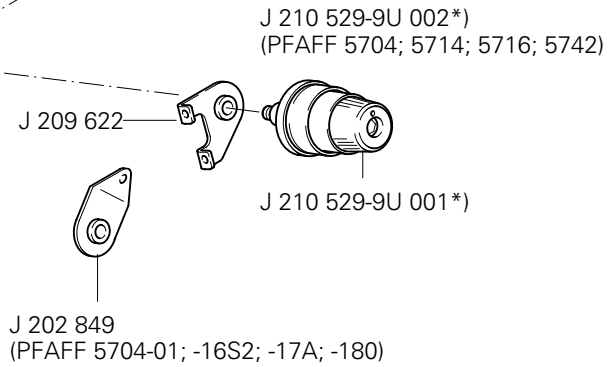
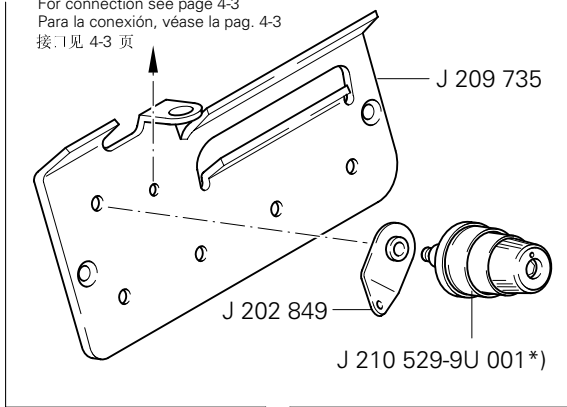

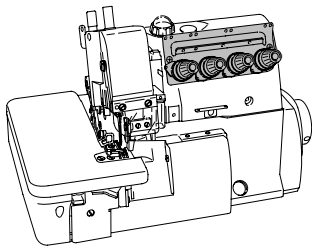
Anschluß siehe Seite 4-3  
For connection see page 4-3  
Para la conexión, véase la pag. 4-3  
接口见 4-3 页



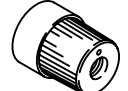

Unterklasse Subclasse Subclase 子机型				
5704-01	J210529-9U002 <sup>2</sup> J210530-9U003 <sup>3</sup> J210531-9U004 <sup>4</sup>	J201037 J201086 J201068	J208450-UA002 <sup>2</sup> J208450-UA003 <sup>3</sup> J208450-UA004 <sup>4</sup>	J208447-UA002 <sup>2</sup> J208447-UA003 <sup>3</sup> J208447-UA004 <sup>4</sup>
5704-16S2	J210529-9U002 <sup>2</sup> J210530-9U003 <sup>3</sup> J210531-9U004 <sup>4</sup>	J201037 J201086 J201068	J208450-UA002 <sup>2</sup> J208450-UA003 <sup>3</sup> J208450-UA004 <sup>4</sup>	J208447-UA002 <sup>2</sup> J208447-UA003 <sup>3</sup> J208447-UA004 <sup>4</sup>
5704-17A	J210529-9U002 <sup>2</sup> J210530-9U003 <sup>3</sup> J210531-9U004 <sup>4</sup>	J201037 J201086 J201068	J208450-UA002 <sup>2</sup> J208450-UA003 <sup>3</sup> J208450-UA004 <sup>4</sup>	J208447-UA002 <sup>2</sup> J208447-UA003 <sup>3</sup> J208447-UA004 <sup>4</sup>
5704-180	J210529-9U001 <sup>1</sup> J210530-9U003 <sup>3</sup> J210531-9U004 <sup>4</sup>	J201037 J201086 J201068	J208450-UA001 <sup>1</sup> J208450-UA003 <sup>3</sup> J208450-UA004 <sup>4</sup>	J208447-UA001 <sup>1</sup> J208447-UA003 <sup>3</sup> J208447-UA004 <sup>4</sup>
5714-13A	J210529-9U001 <sup>1</sup> J210529-9U002 <sup>2</sup> J210530-9U003 <sup>3</sup> J210531-9U004 <sup>4</sup>	J201037 J201037 J201086 J201068	J208450-UA001 <sup>1</sup> J208450-UA002 <sup>2</sup> J208450-UA003 <sup>3</sup> J208450-UA004 <sup>4</sup>	J208447-UA001 <sup>1</sup> J208447-UA002 <sup>2</sup> J208447-UA003 <sup>3</sup> J208447-UA004 <sup>4</sup>
5714-13H	J210529-9U001 <sup>1</sup> J210529-9U002 <sup>2</sup> J210530-9U003 <sup>3</sup> J210531-9U004 <sup>4</sup>	J201037 J201037 J201086 J201068	J208450-UA001 <sup>1</sup> J208450-UA002 <sup>2</sup> J208450-UA003 <sup>3</sup> J208450-UA004 <sup>4</sup>	J208447-UA001 <sup>1</sup> J208447-UA002 <sup>2</sup> J208447-UA003 <sup>3</sup> J208447-UA004 <sup>4</sup>
5714-181	J210529-9U001 <sup>1</sup> J210529-9U002 <sup>2</sup> J210530-9U003 <sup>3</sup> J210531-9U004 <sup>4</sup>	J201037 J201037 J201086 J201068	J208450-UA001 <sup>1</sup> J208450-UA002 <sup>2</sup> J208450-UA003 <sup>3</sup> J208450-UA004 <sup>4</sup>	J208447-UA001 <sup>1</sup> J208447-UA002 <sup>2</sup> J208447-UA003 <sup>3</sup> J208447-UA004 <sup>4</sup>
5716-38A	J210529-9U001 <sup>1</sup> J210529-9U002 <sup>2</sup> J210530-9U003 <sup>3</sup> J210531-9U004 <sup>4</sup>	J201037 J201037 J201086 J201068	J208450-UA001 <sup>1</sup> J208450-UA002 <sup>2</sup> J208450-UA003 <sup>3</sup> J208450-UA004 <sup>4</sup>	J208447-UA001 <sup>1</sup> J208447-UA002 <sup>2</sup> J208447-UA003 <sup>3</sup> J208447-UA004 <sup>4</sup>
5716-70A	J210529-9U001 <sup>1</sup> J210529-9U002 <sup>2</sup> J210530-9U003 <sup>3</sup> J210531-9U004 <sup>4</sup>	J201037 J201037 J201086 J201068	J208450-UA001 <sup>1</sup> J208450-UA002 <sup>2</sup> J208450-UA003 <sup>3</sup> J208450-UA004 <sup>4</sup>	J208447-UA001 <sup>1</sup> J208447-UA002 <sup>2</sup> J208447-UA003 <sup>3</sup> J208447-UA004 <sup>4</sup>
5716-86A	J210529-9U001 <sup>1</sup> J210529-9U002 <sup>2</sup> J210530-9U003 <sup>3</sup> J210531-9U004 <sup>4</sup>	J201037 J201037 J201086 J201068	J208450-UA001 <sup>1</sup> J208450-UA002 <sup>2</sup> J208450-UA003 <sup>3</sup> J208450-UA004 <sup>4</sup>	J208447-UA001 <sup>1</sup> J208447-UA002 <sup>2</sup> J208447-UA003 <sup>3</sup> J208447-UA004 <sup>4</sup>
5742-02-250	J210529-9U001 <sup>1</sup> J210529-9U002 <sup>2</sup>	J201037 J201037	J208450-UA001 <sup>1</sup> J208450-UA002 <sup>2</sup>	J208447-UA001 <sup>1</sup> J208447UA002 <sup>2</sup>

- 1** 001 = orange  
001 = orange  
001 = anaranjado  
001 = 橙
 **2** 002 = ocker  
002 = ochre  
002 = ocre  
002 = 赭
 **3** 003 = gelb  
003 = yellow  
003 = amarillo  
003 = 黄
 **4** 004 = blau  
004 = blue  
004 = azul  
004 = 蓝

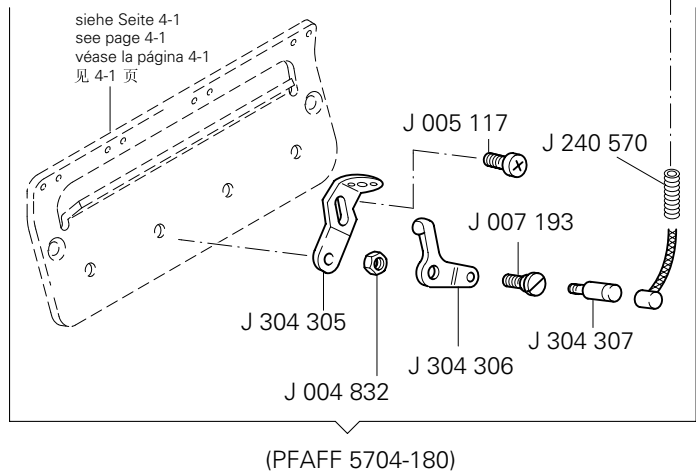
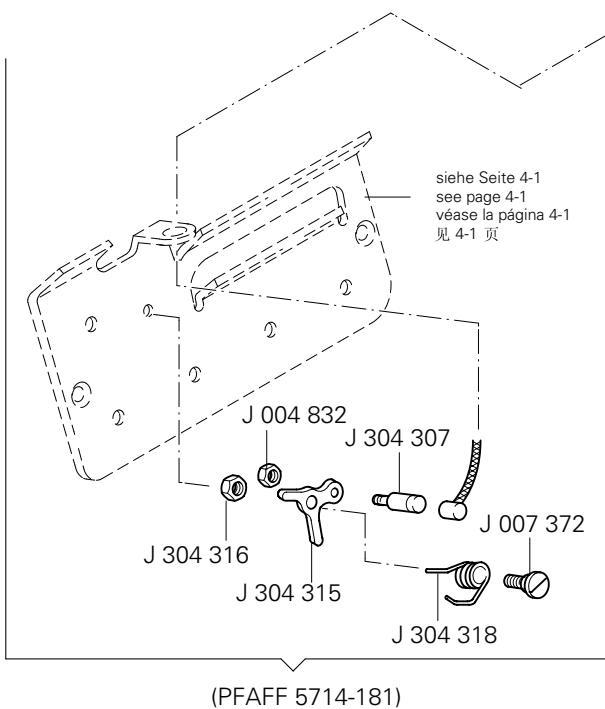
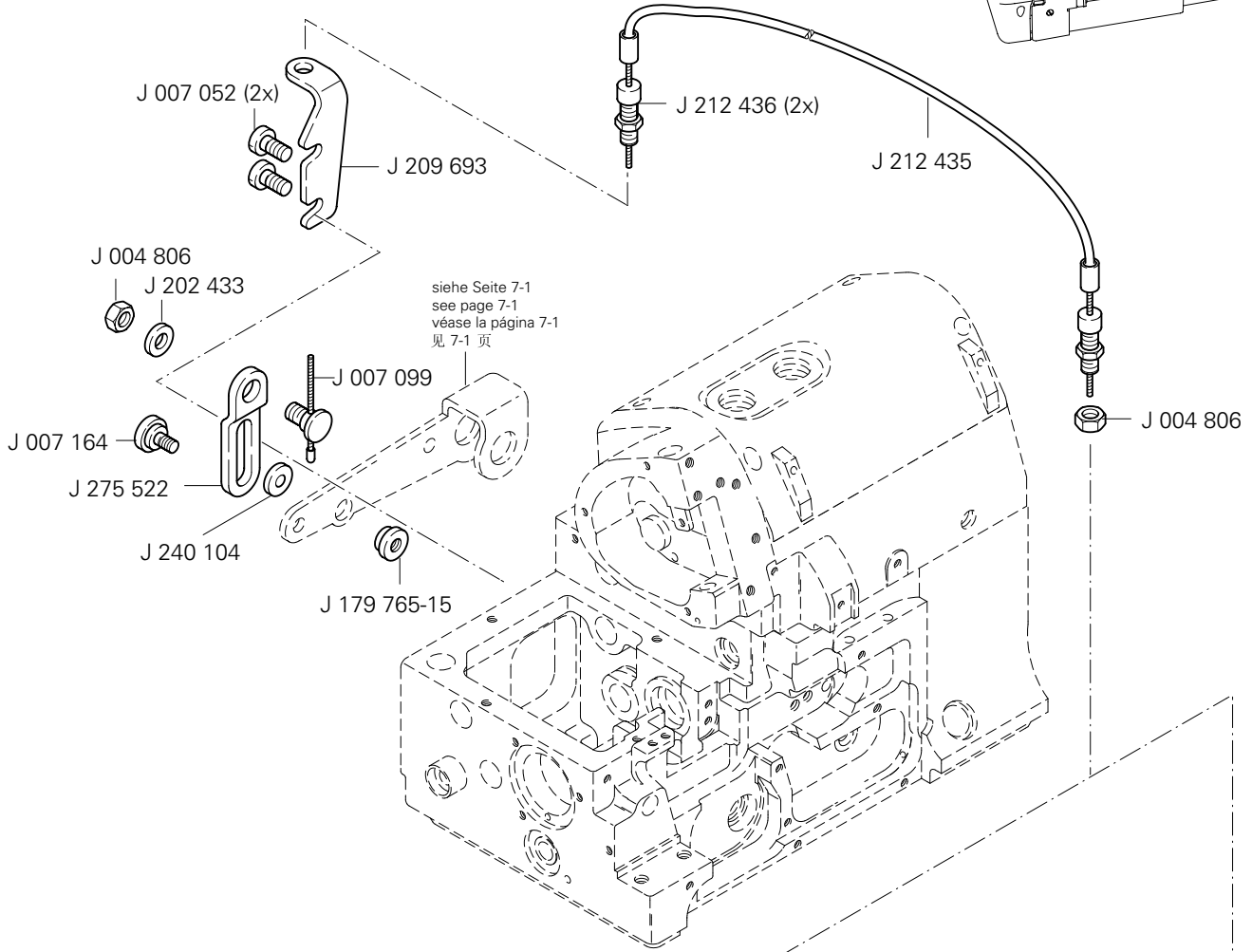
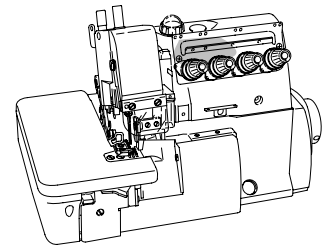

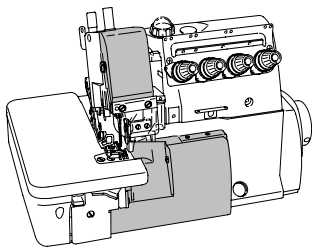

Fadenführungen und Fadenspannungen  
 Thread guides and thread tensions  
 Guiahilos y tensahilos  
 导线架和缝线张紧装置

PFAFF 5704  
 PFAFF 5714  
 PFAFF 5716  
 PFAFF 5742

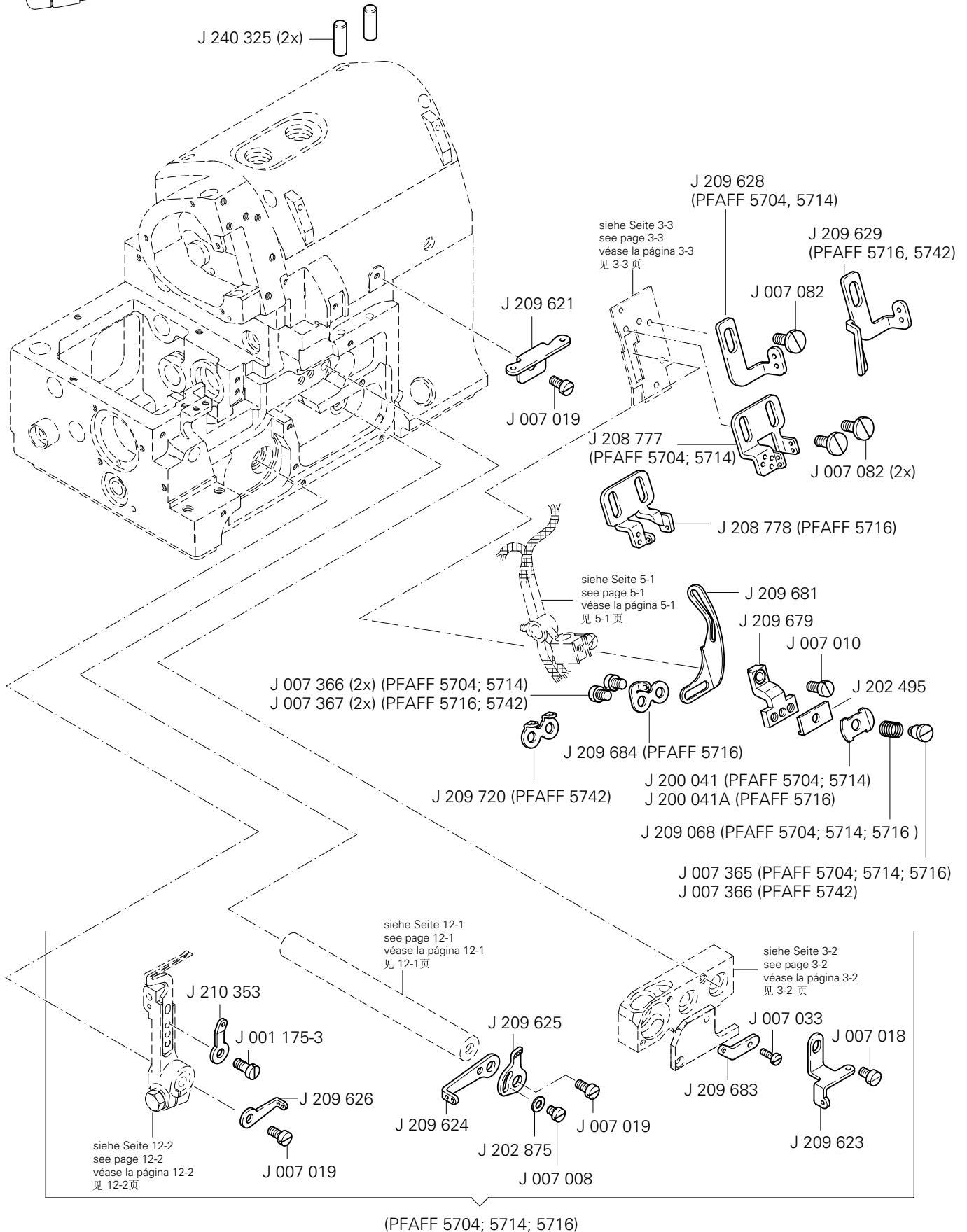

# 4

## Fadenführungen und Fadenspannungen Thread guides and thread tensions Guiarhilos y tensarhilos 导线架和缝线张紧装置

PFAFF 5716  
PFAFF 5742

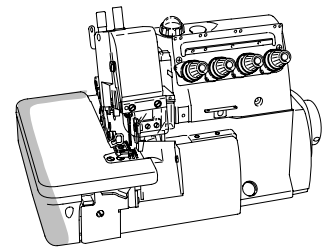

(PFAFF 5742)

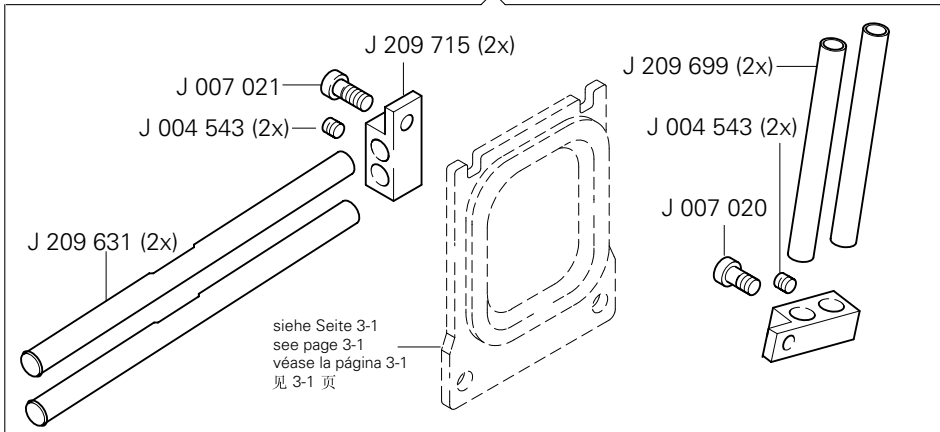

(PFAFF 5716)

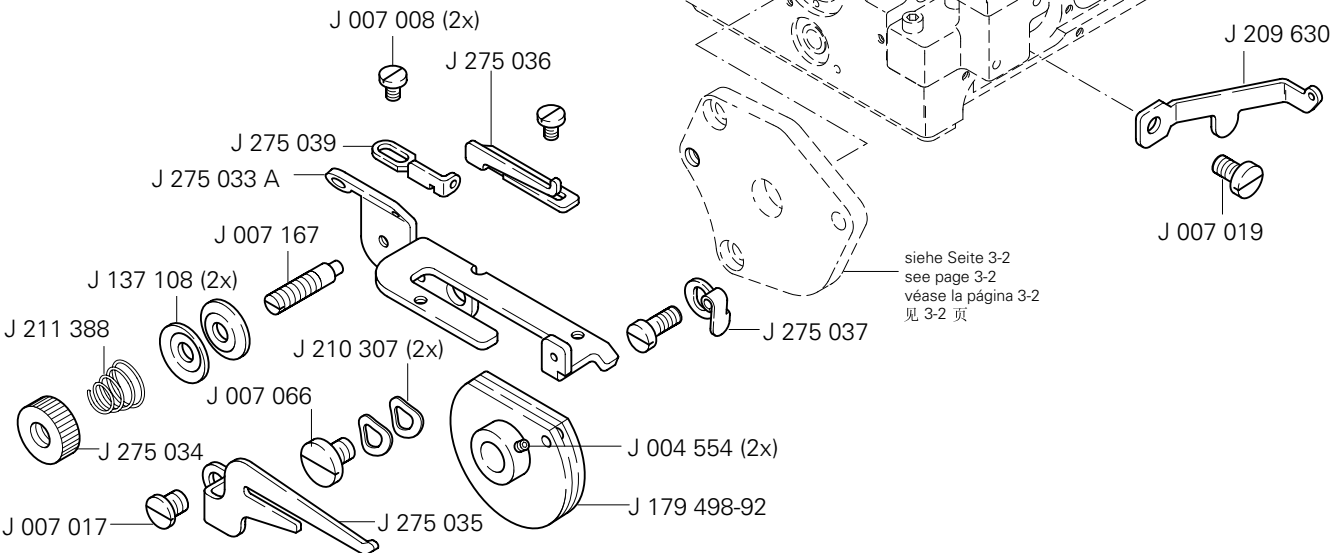
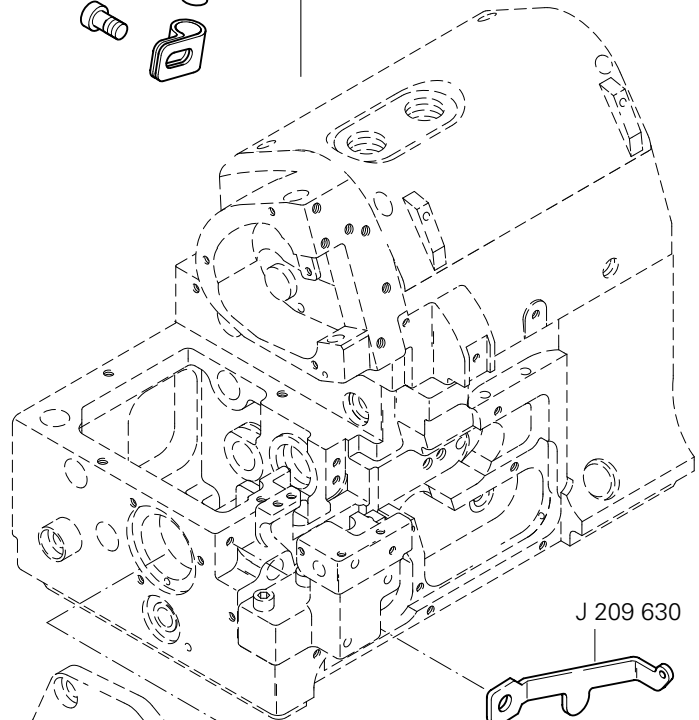
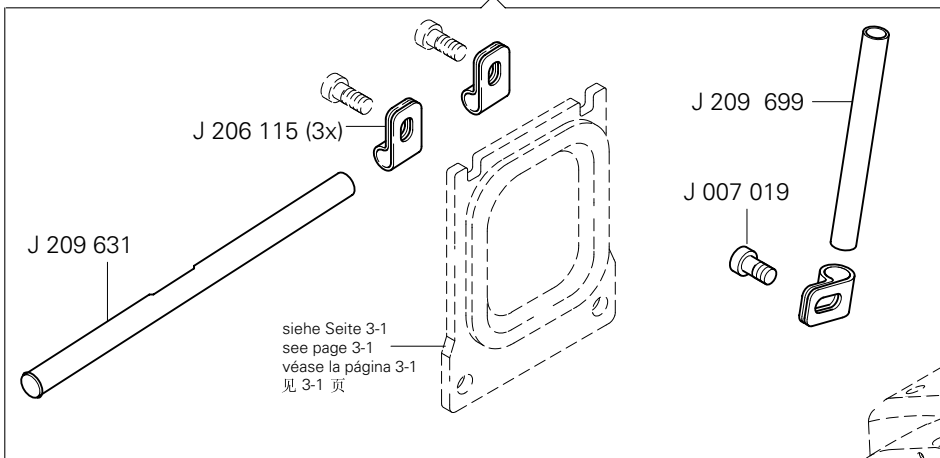



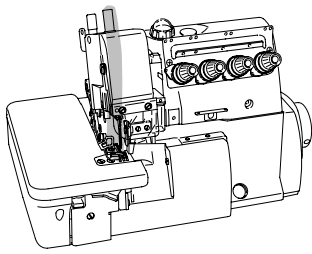

Nadelstangenantrieb  
Needle drive mechanism  
Accionamiento de la barra agujas  
针杆驱动器

PFAFF 5704  
PFAFF 5714  
PFAFF 5716  
PFAFF 5742

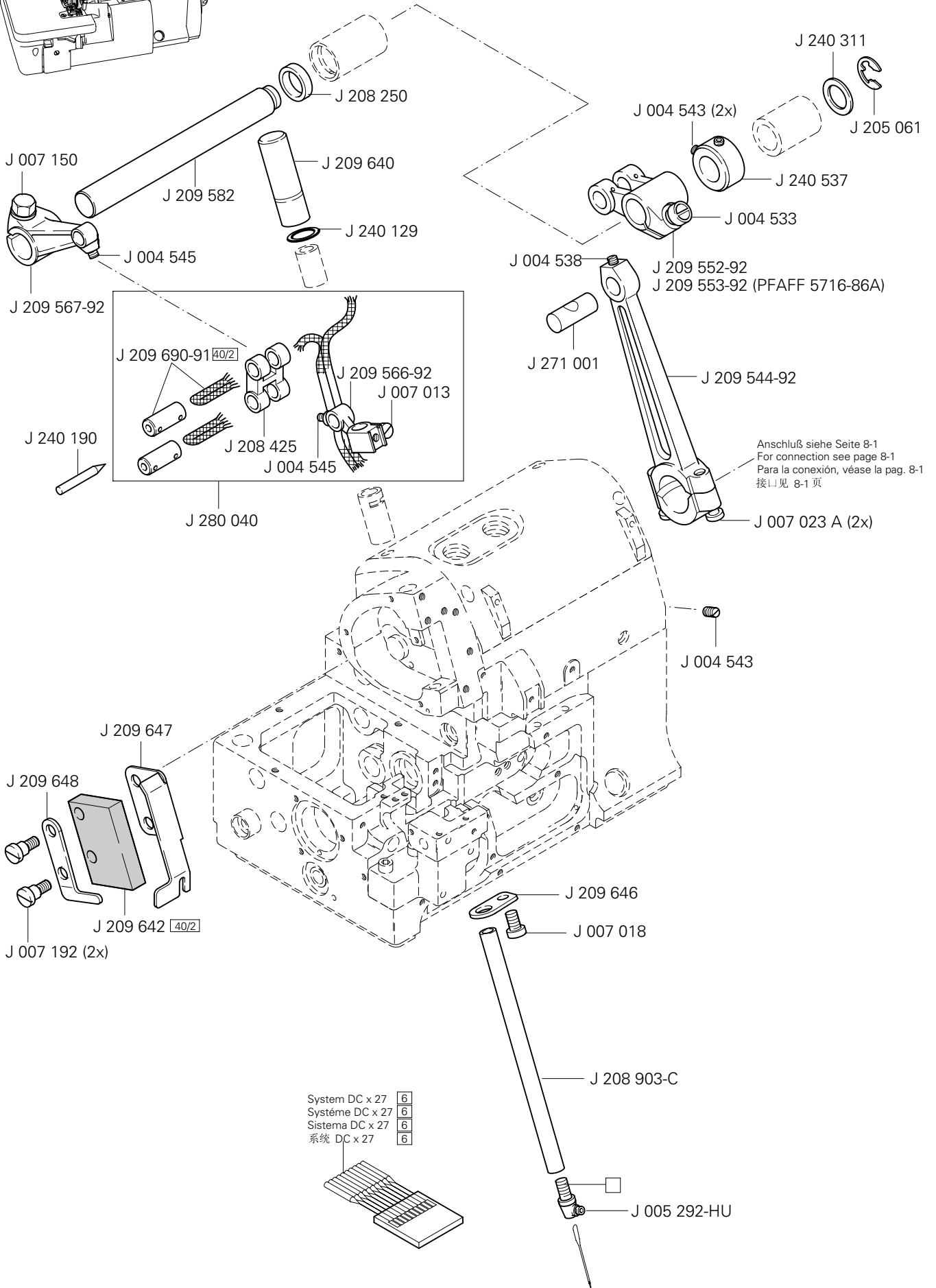

System DC x 27 

6
---

  
Système DC x 27 

6
---

  
Sistema DC x 27 

6
---

  
系统 DC x 27 

6
---

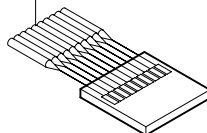

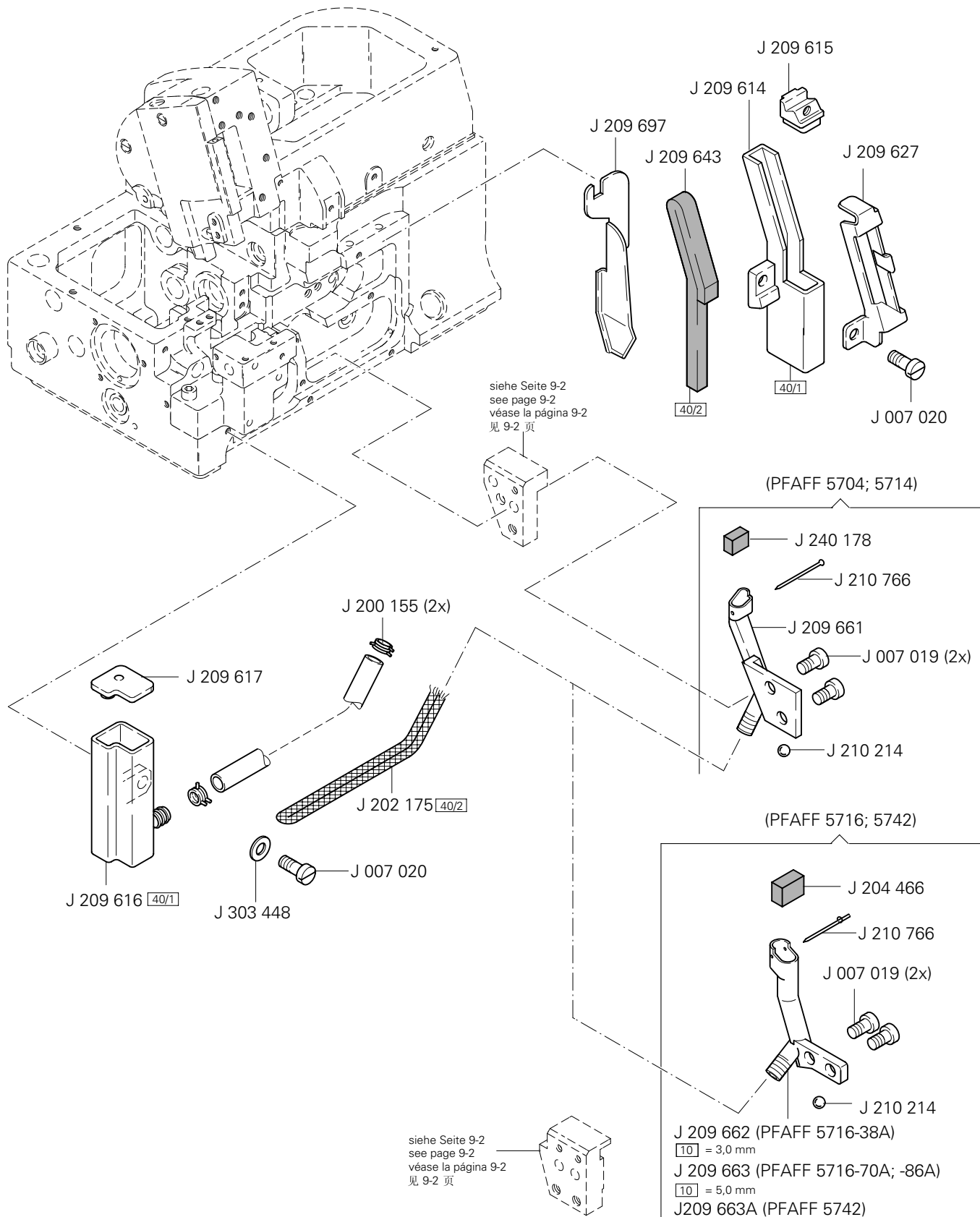
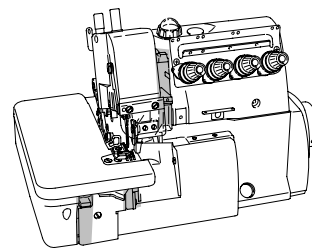

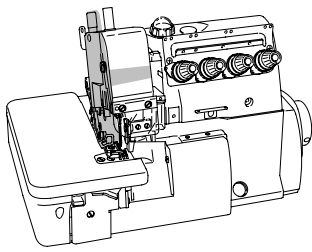

Stoffdrückerfußaggregat  
 Presser foot assembly  
 Mecanismo del pie prensatelas  
 压脚装置

PFAFF 5704  
 PFAFF 5714  
 PFAFF 5716  
 PFAFF 5742

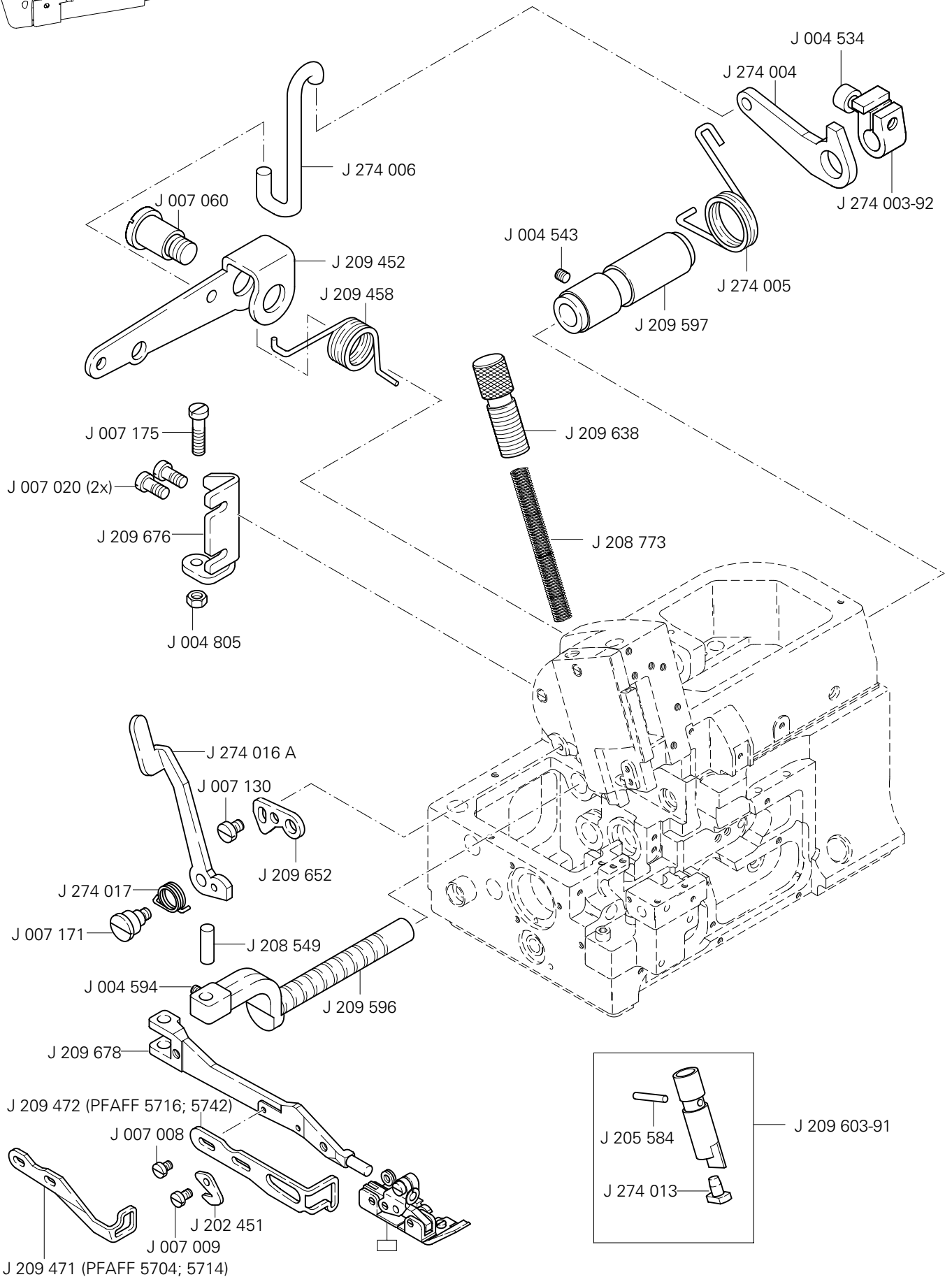

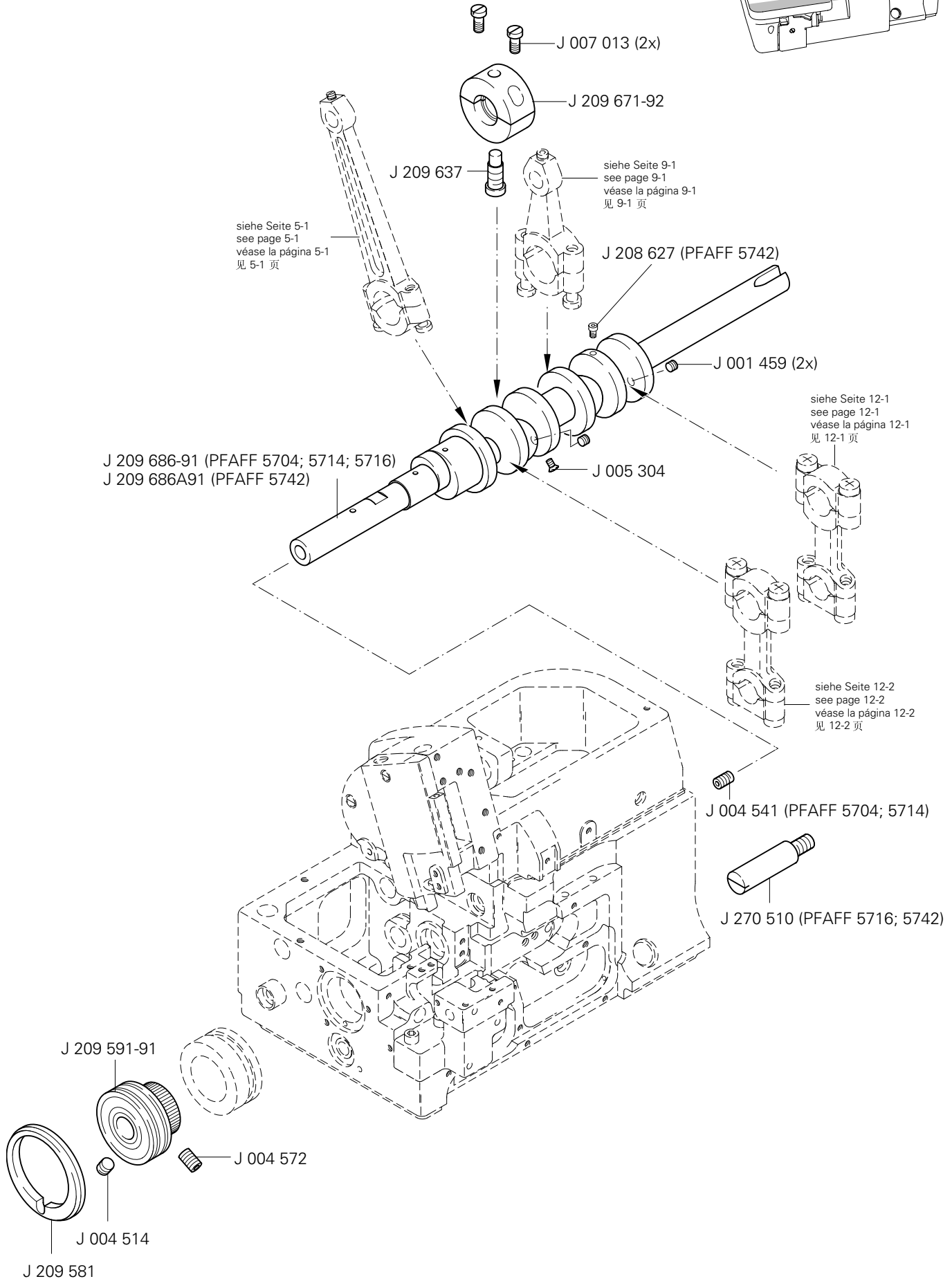
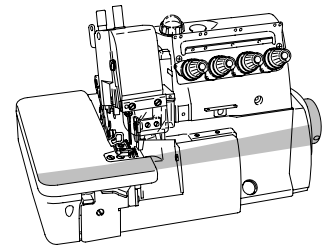

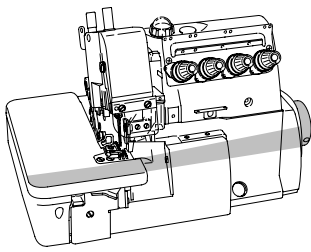

Kurbelwellenaggregat  
Crank shaft mechanism  
Mecanismo de transmisión por manivela  
曲轴装置

PFAFF 5704  
PFAFF 5714  
PFAFF 5716  
PFAFF 5742

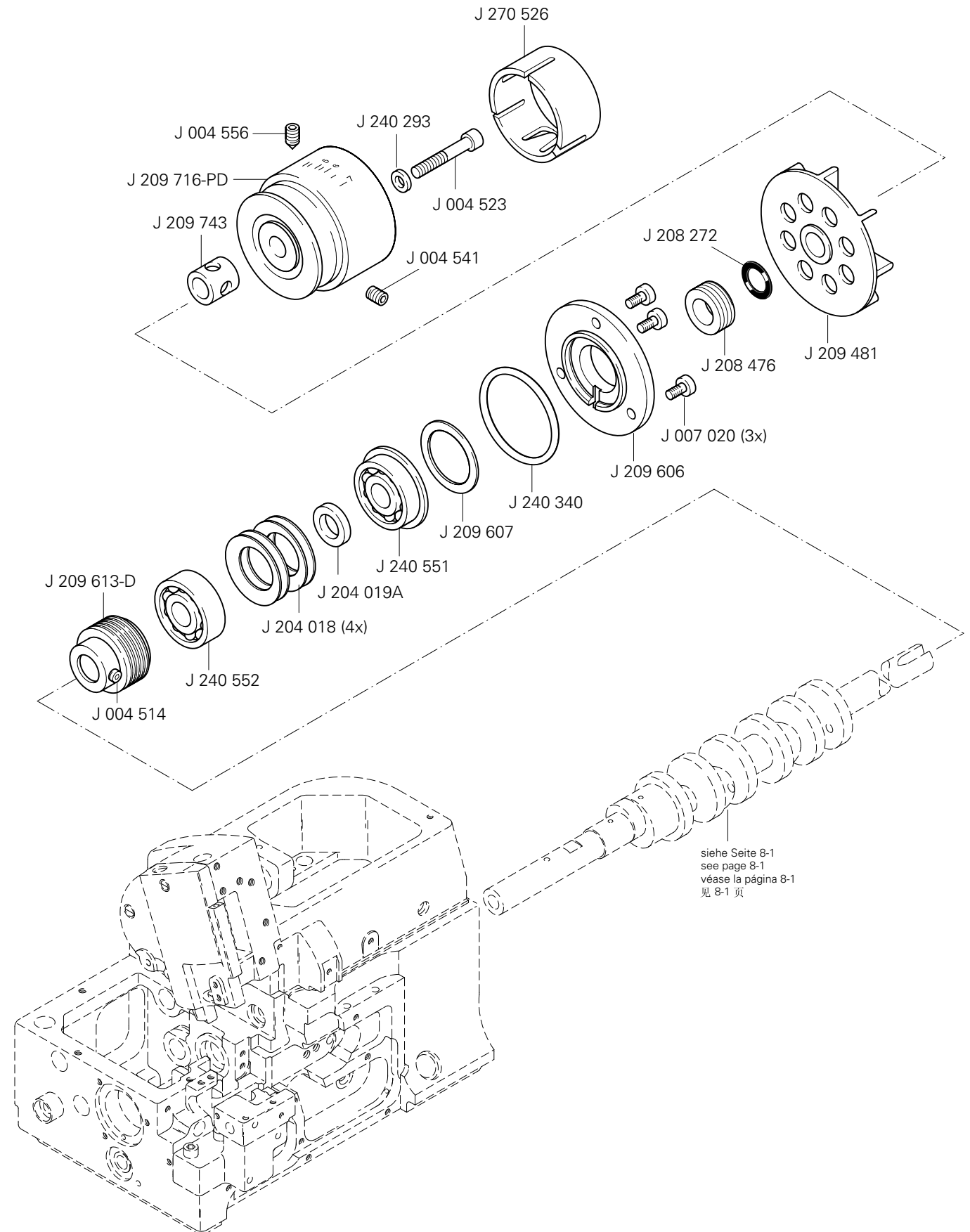

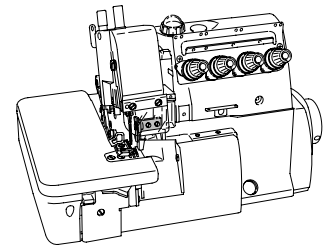

(PFAFF 5742)

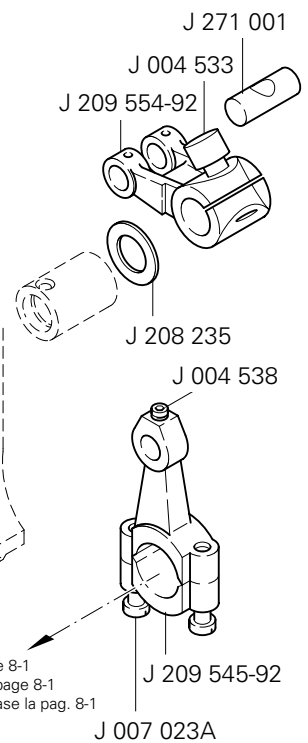
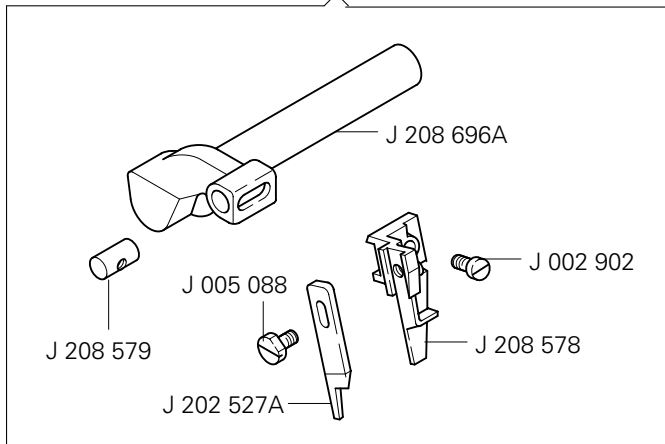

Anschluß siehe Seite 8-1  
 For connection see page 8-1  
 Para la conexión, véase la pag. 8-1  
 接。1见 8-1 页

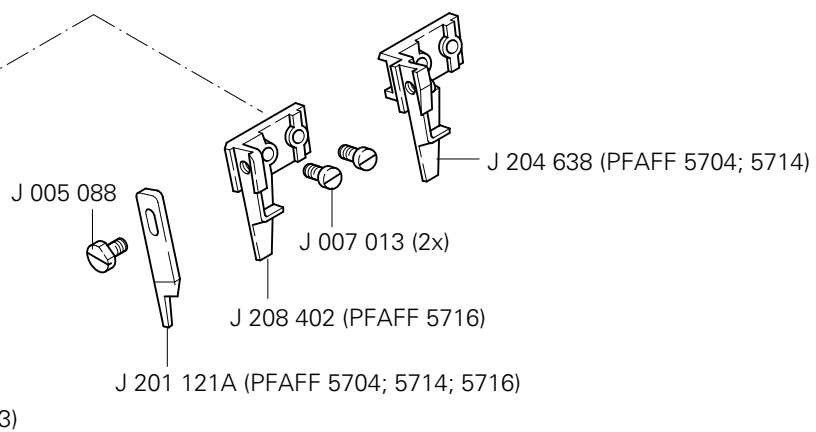
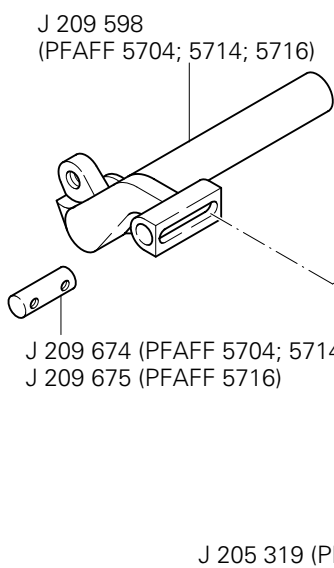

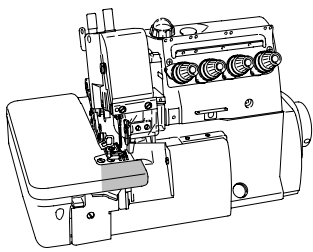

Messerantrieb  
 Knife drive mechanism  
 Mecanismo de accionamiento de la cuchilla  
 切刀驱动器

PFAFF 5704  
 PFAFF 5714  
 PFAFF 5716  
 PFAFF 5742

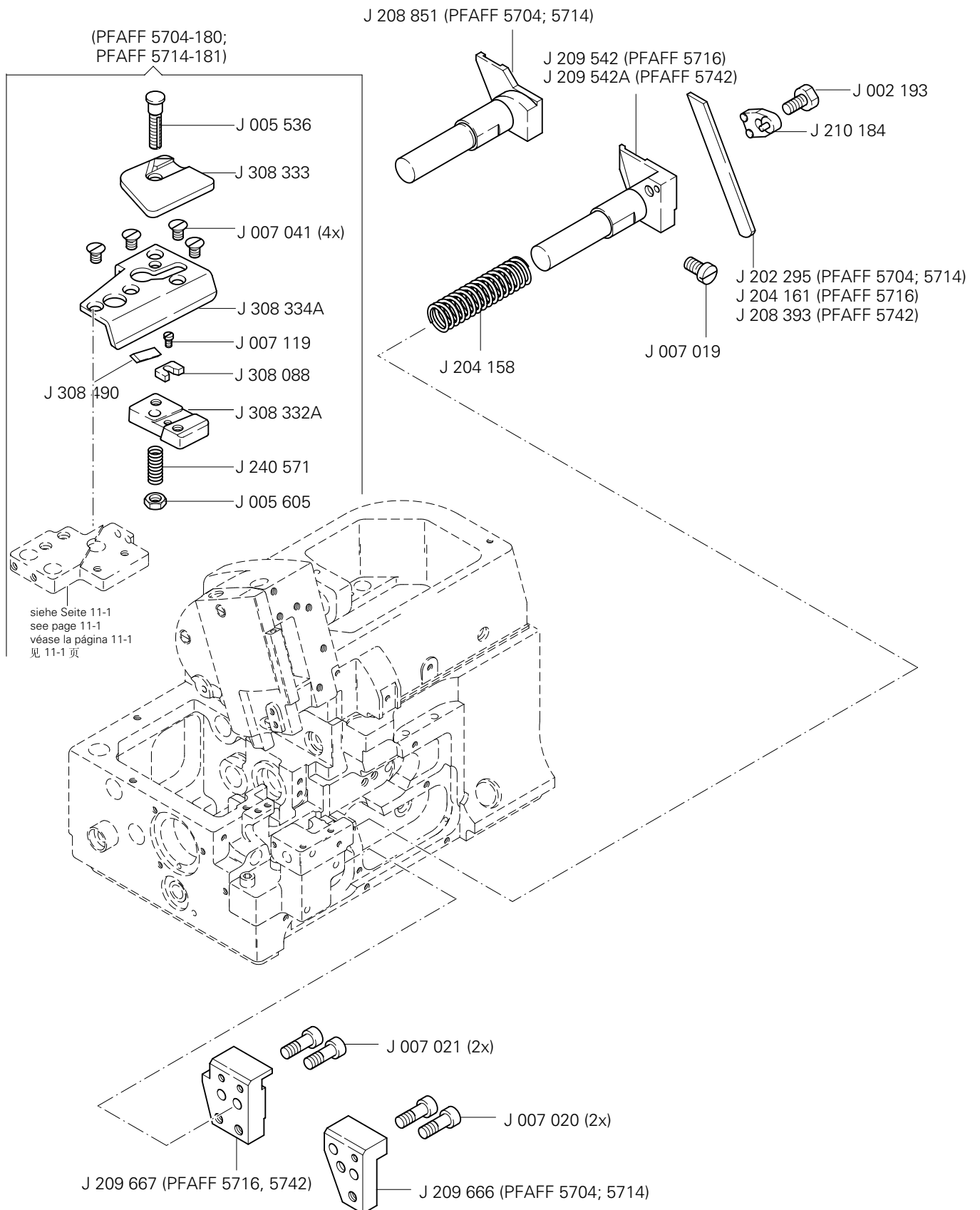

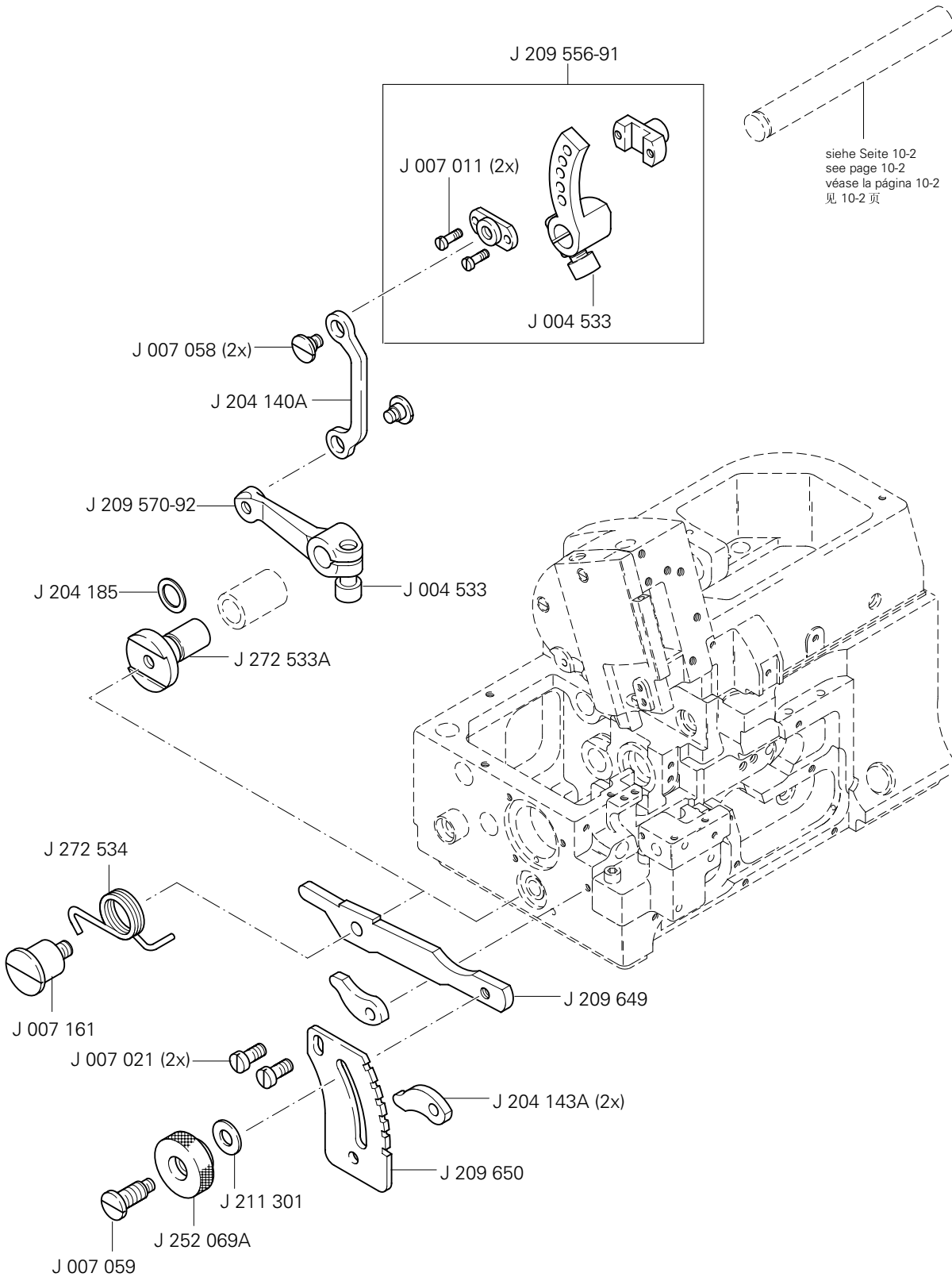
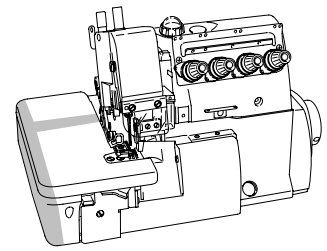



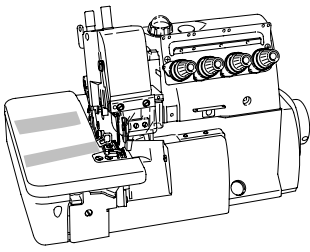

Transportmechanismus  
Feed mechanism  
Mecanismo de arrastre  
送料机构

PFAFF 5704  
PFAFF 5714  
PFAFF 5716  
PFAFF 5742

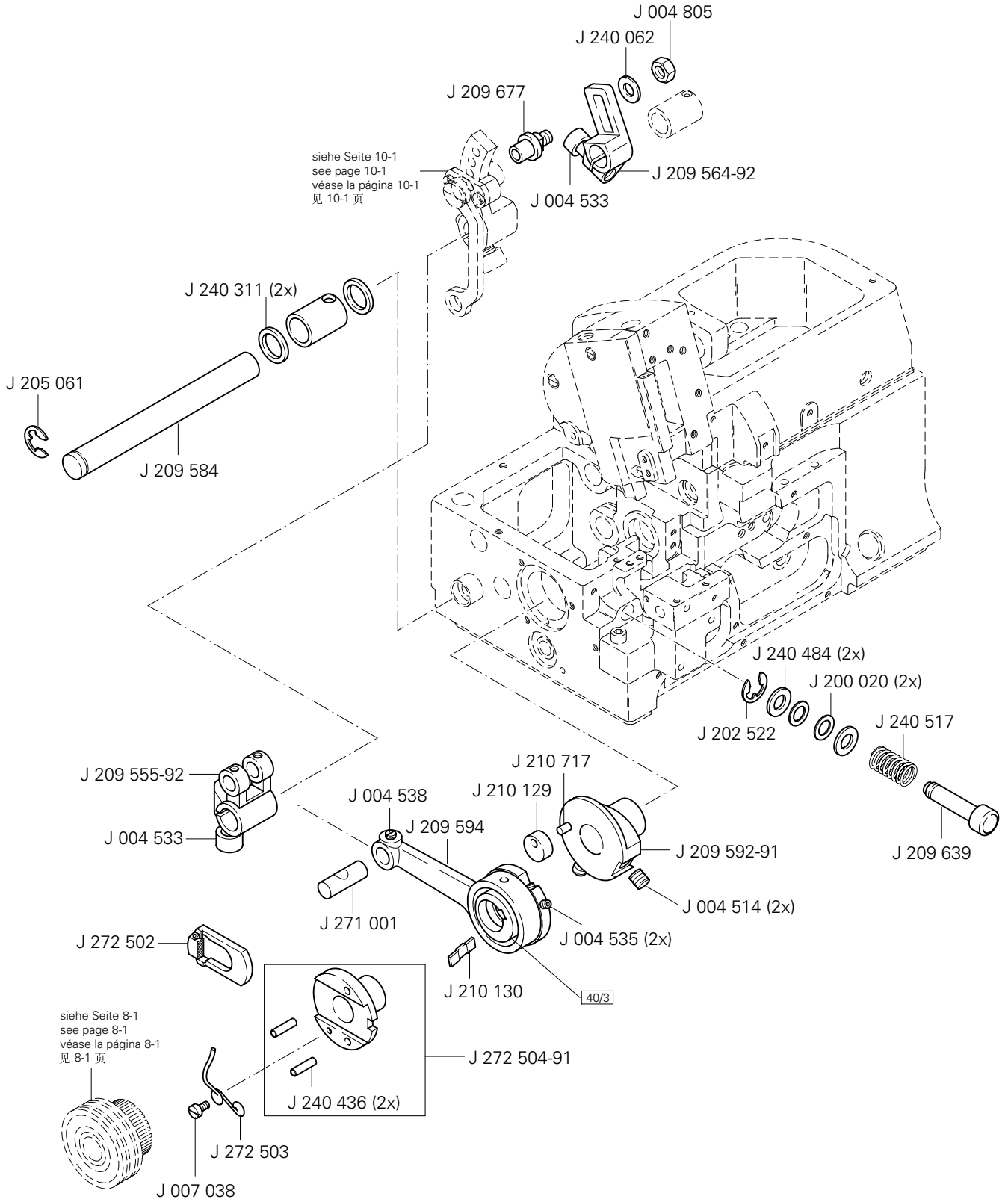

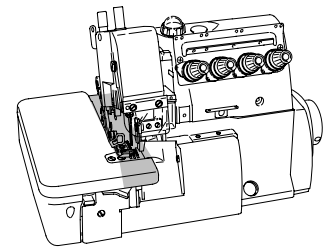

siehe Seite 10-2  
see page 10-2  
véase la página 10-2  
見 10-2 页

siehe Seite 10-1  
see page 10-1  
véase la página 10-1  
見 10-1 页

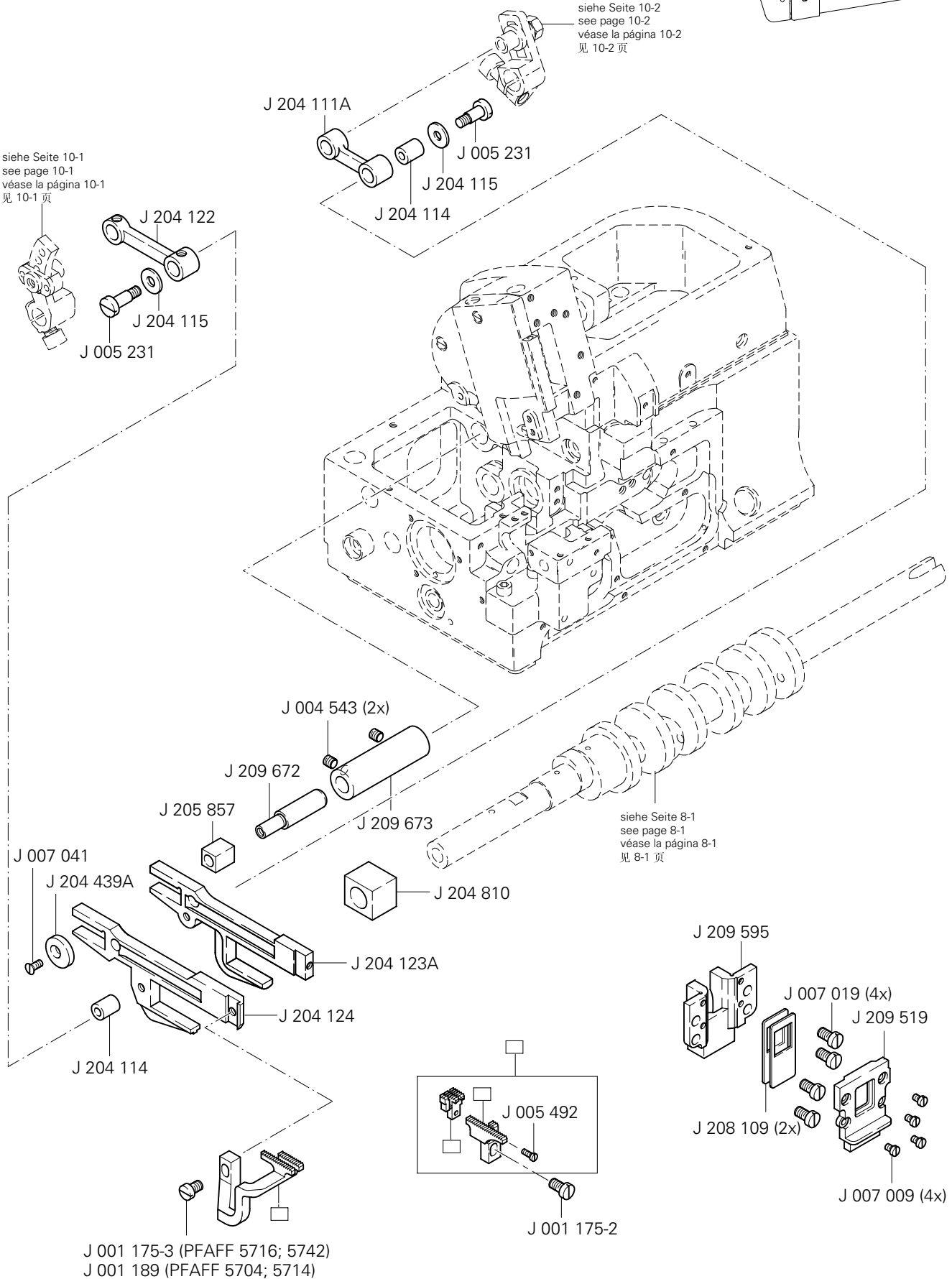

siehe Seite 8-1  
see page 8-1  
véase la página 8-1  
見 8-1 页

J 001 175-3 (PFAFF 5716; 5742)  
J 001 189 (PFAFF 5704; 5714)

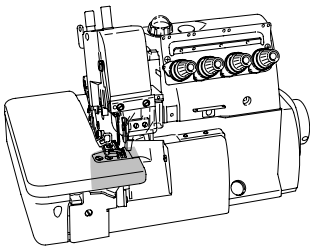

Nadelschutzteile  
Needle guard parts  
Piezas de protección de aguja  
护针零件

PFAFF 5704  
PFAFF 5714  
PFAFF 5716  
PFAFF 5742

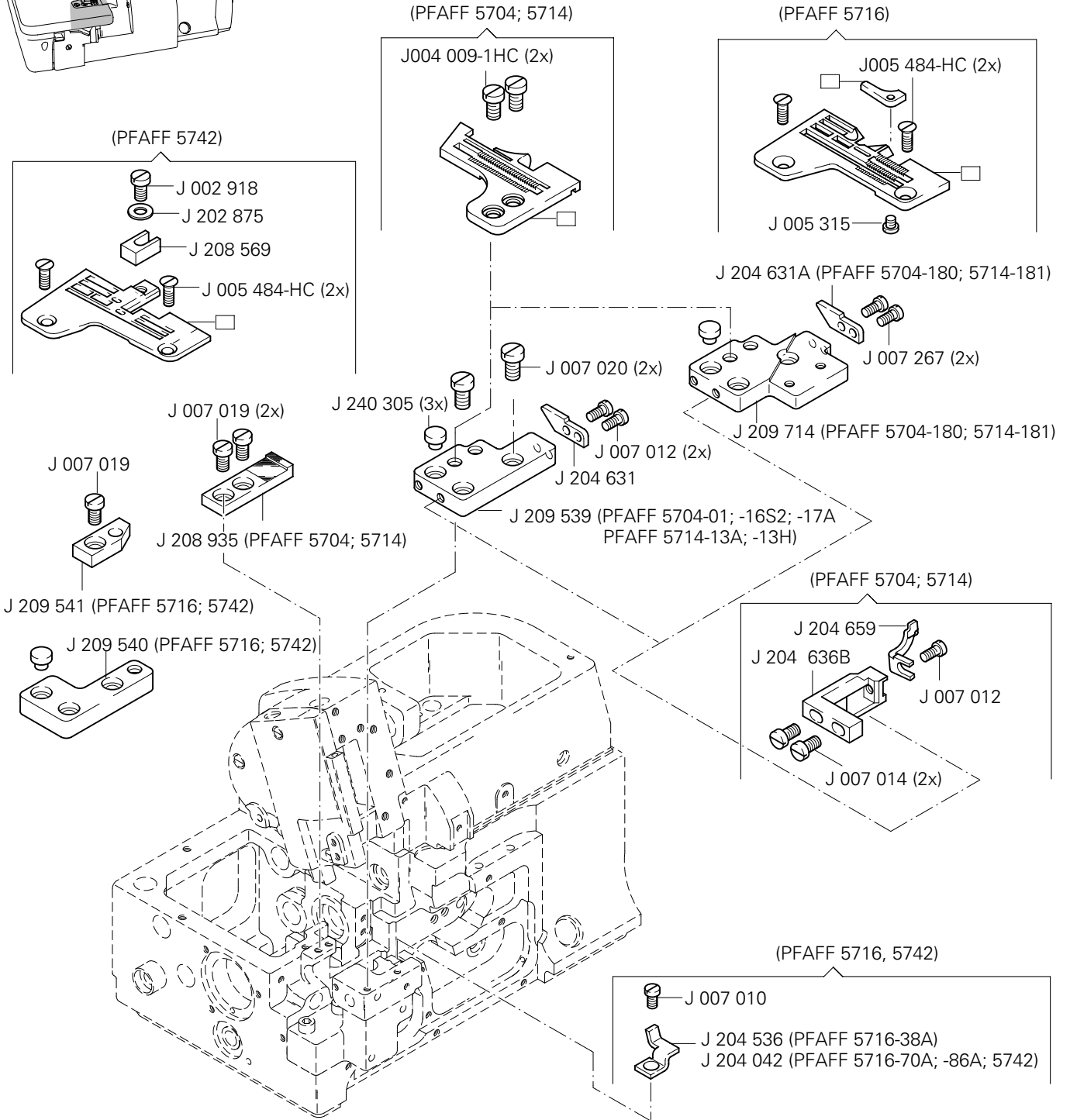

(PFAFF 5704; 5714; 5716)

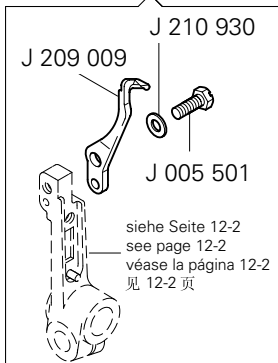

(PFAFF 5716)

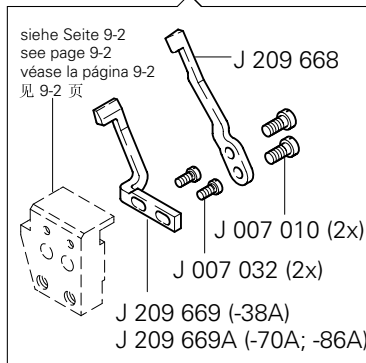

(PFAFF 5742)

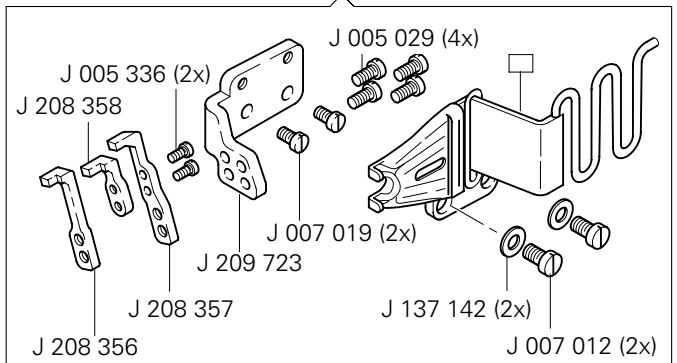

# 12 Greiferantrieb Looper drive mechanism Accionamiento del garfio derecho 弯针驱动器

PFAFF 5704  
PFAFF 5714  
PFAFF 5716

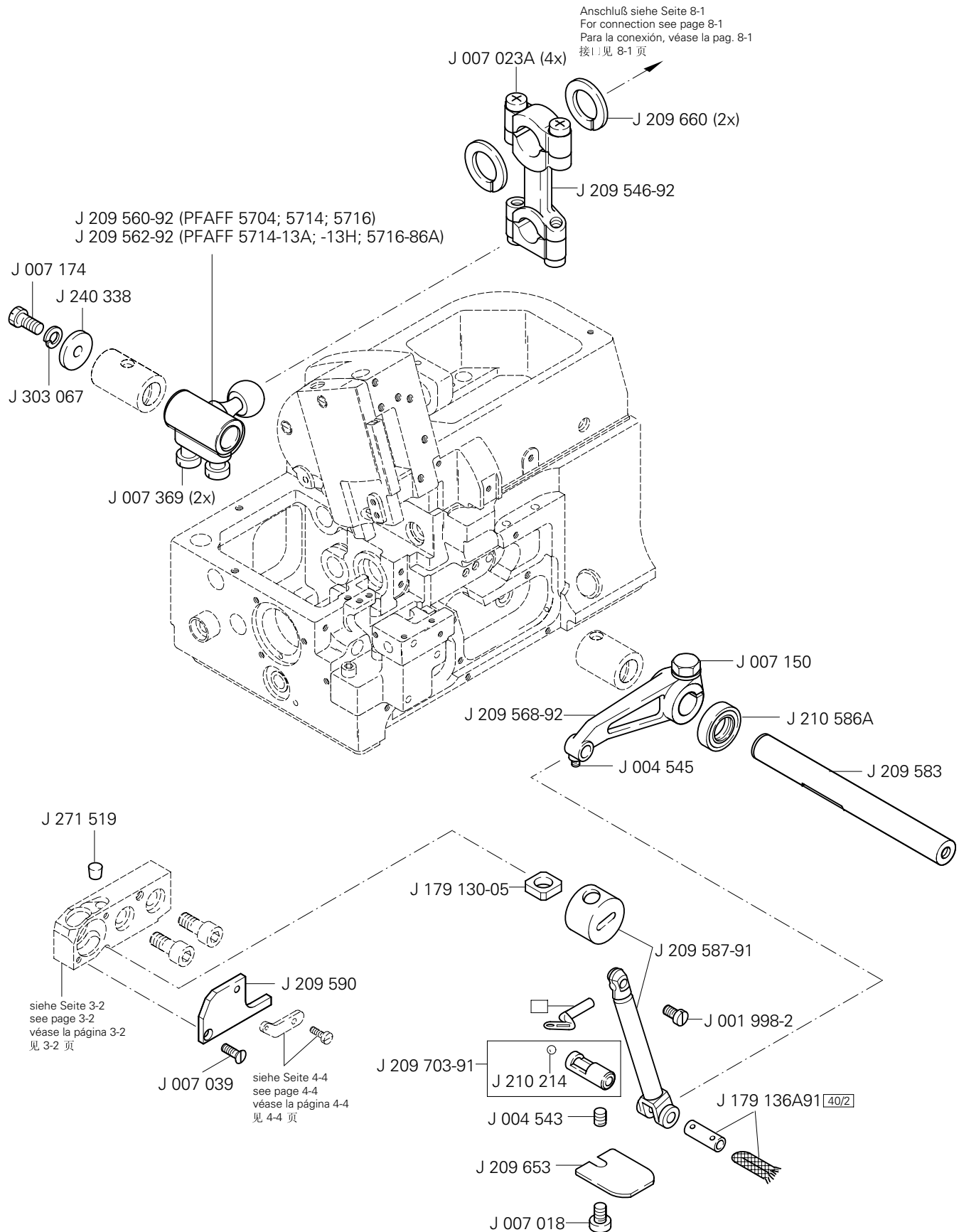
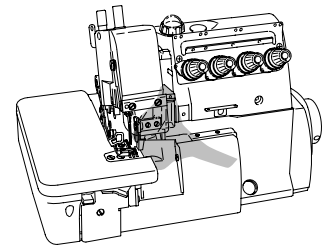

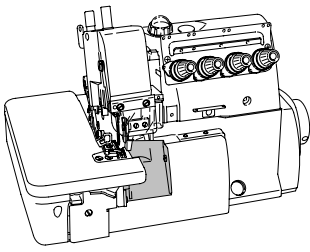

Greiferantrieb  
 Looper drive mechanism  
 Accionamiento del garfio derecho  
 弯针驱动器

PFAFF 5704  
 PFAFF 5714  
 PFAFF 5716  
 PFAFF 5742

Anschluß siehe Seite 8-1  
 For connection see page 8-1  
 Para la conexión, véase la pag. 8-1  
 接 1 见 8-1 页

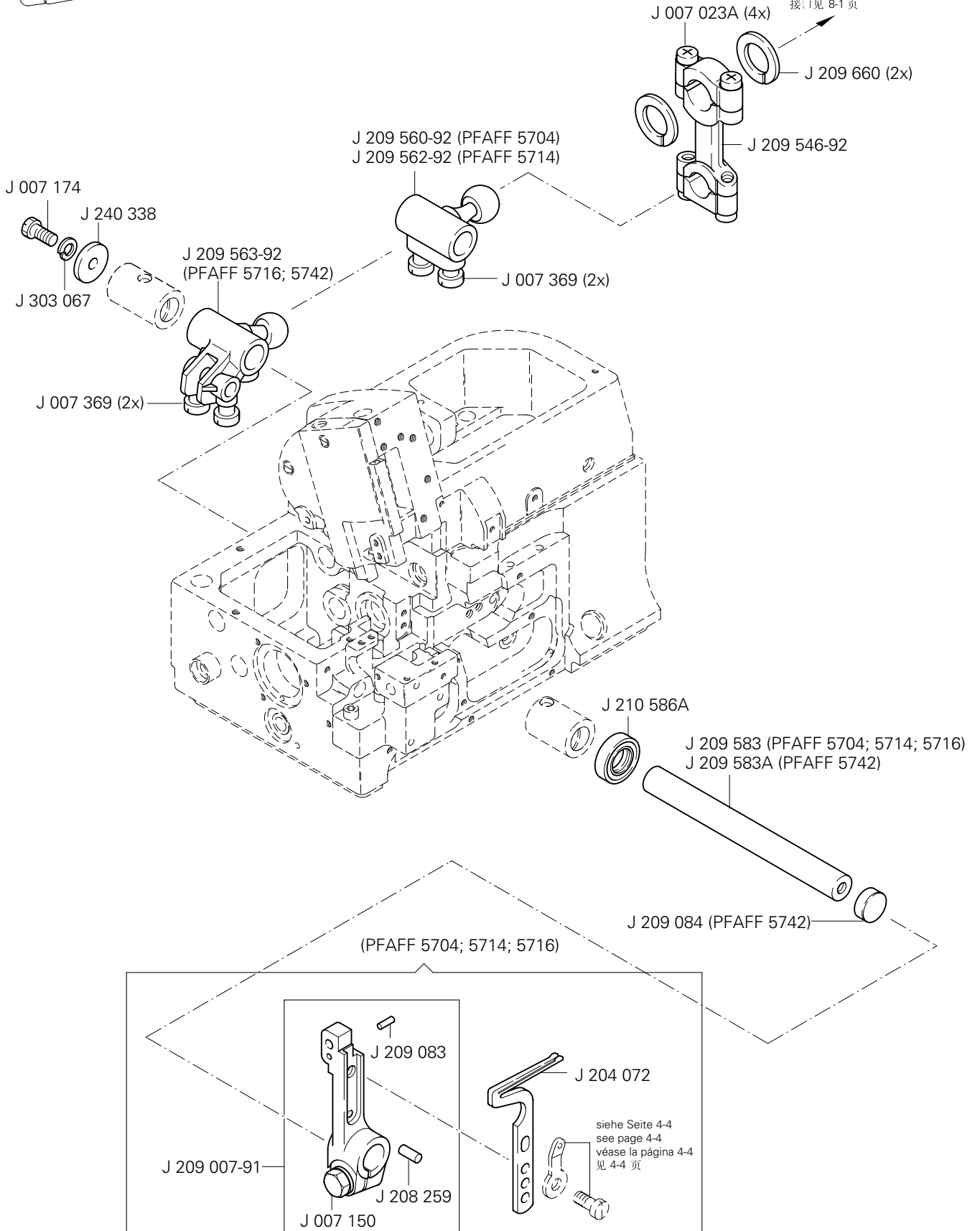

# 12

Greiferantrieb  
 Looper drive mechanism  
 Accionamiento del garfio derecho  
 弯针驱动器

PFAFF 5716  
 PFAFF 5742

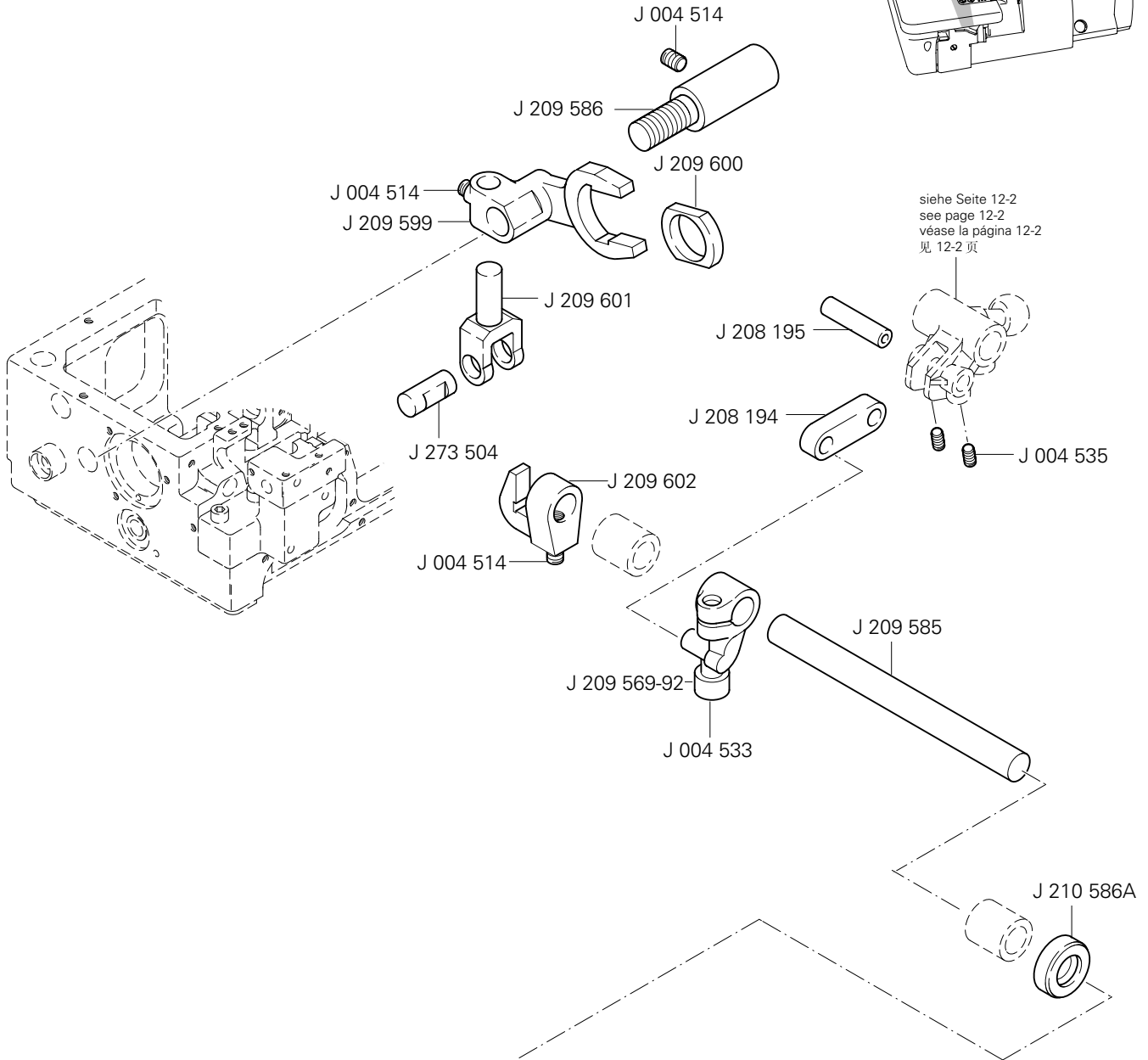
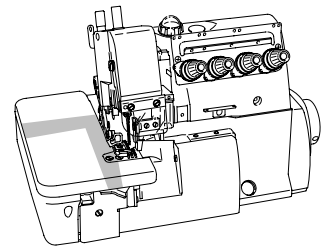

siehe Seite 12-2  
 see page 12-2  
 véase la página 12-2  
 见 12-2 页

(PFAFF 5716)

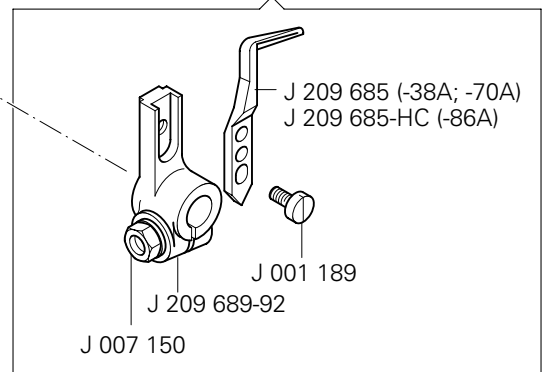

(PFAFF 5742)

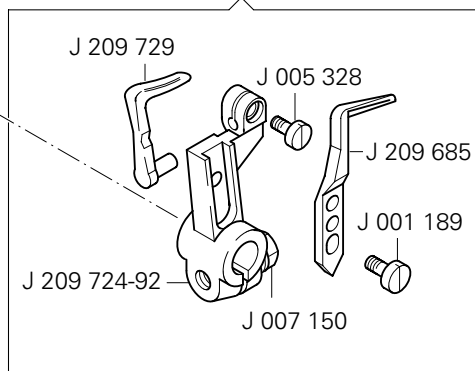

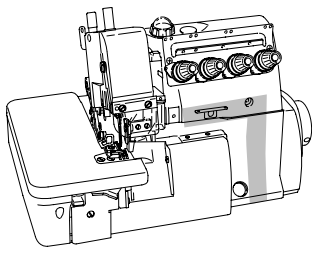

Schmierungssystem  
Lubricating system  
Sistema de engrase  
润滑系统

PFAFF 5704  
PFAFF 5714  
PFAFF 5716  
PFAFF 5742

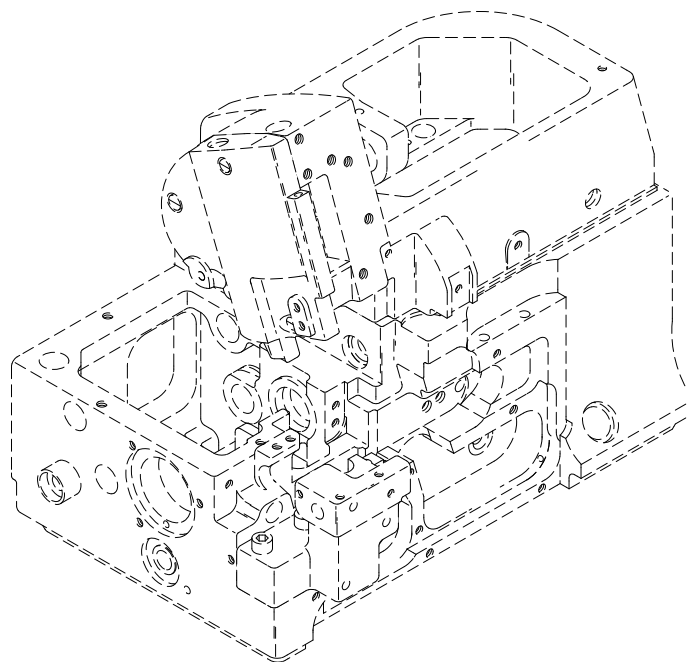
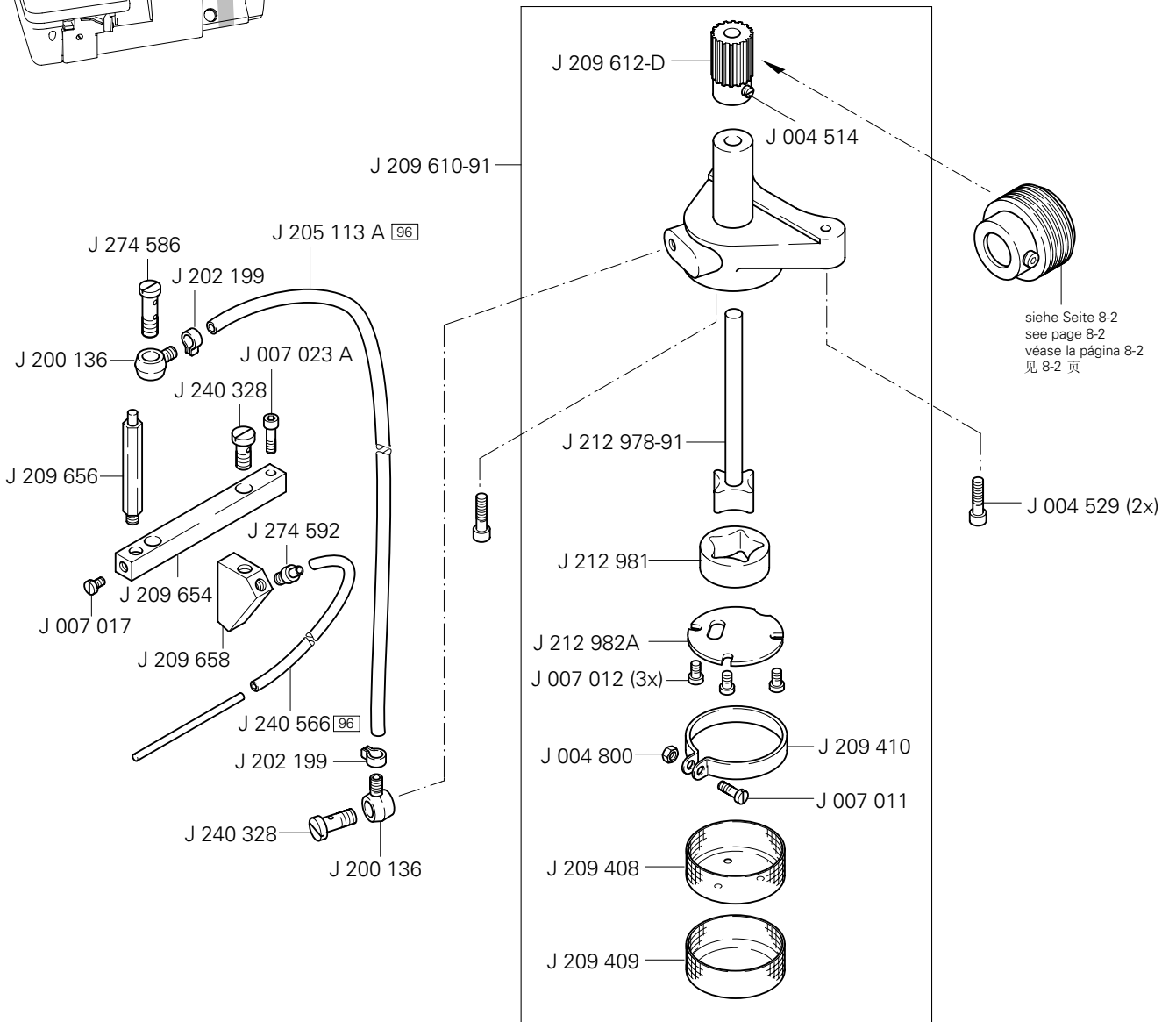

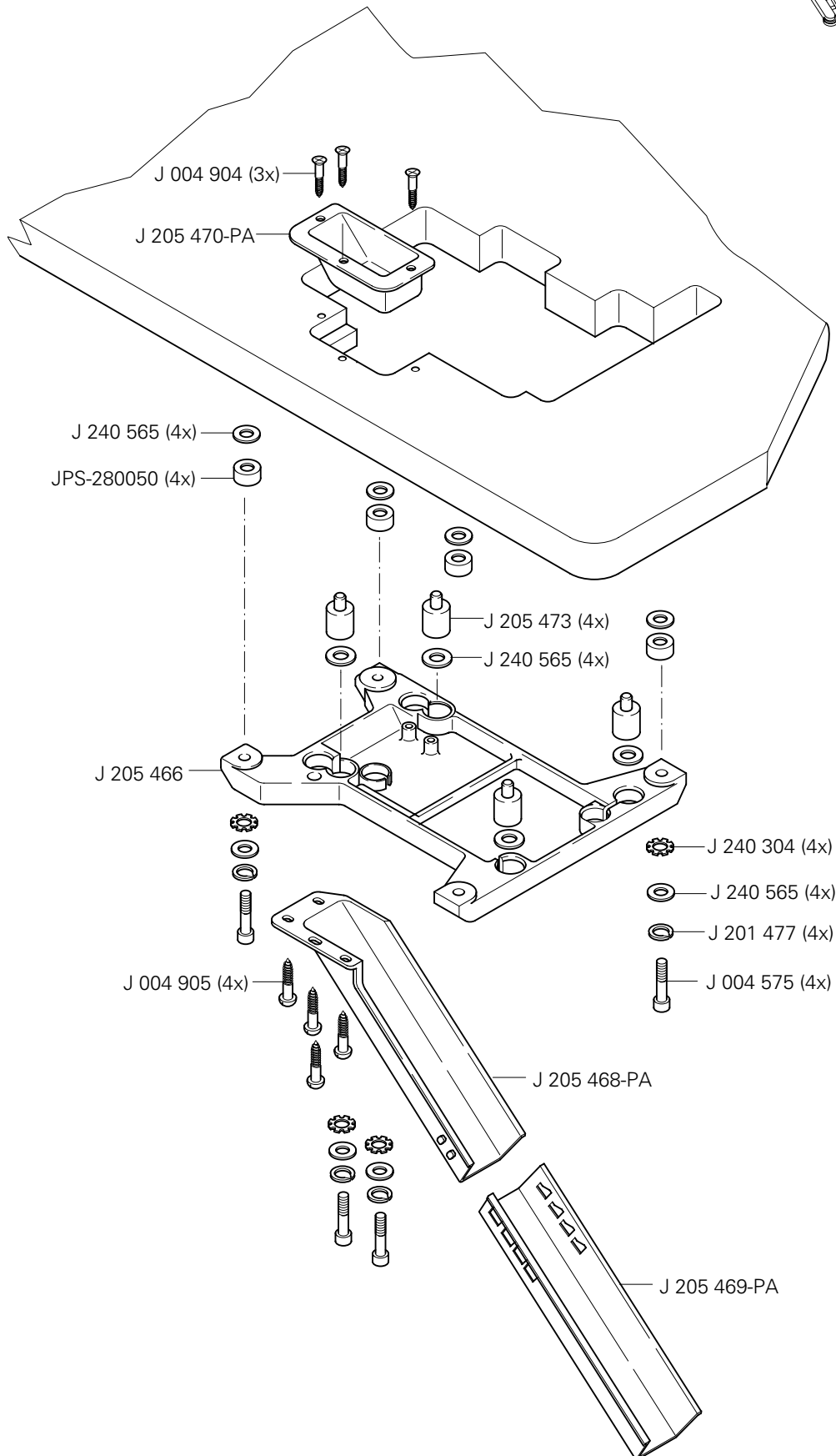
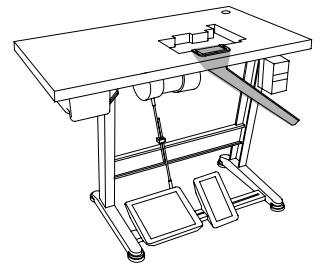



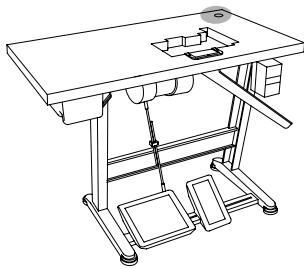

Garnrollenständer  
Reel stands  
Portacarretes  
线轴支架

PFAFF 5704  
PFAFF 5714  
PFAFF 5716  
PFAFF 5742

J 000 486 C9P (PFAFF 5704)  
J 000 486 B9P (PFAFF 5714; 5742)  
J 000 486 A9P (PFAFF 5716)

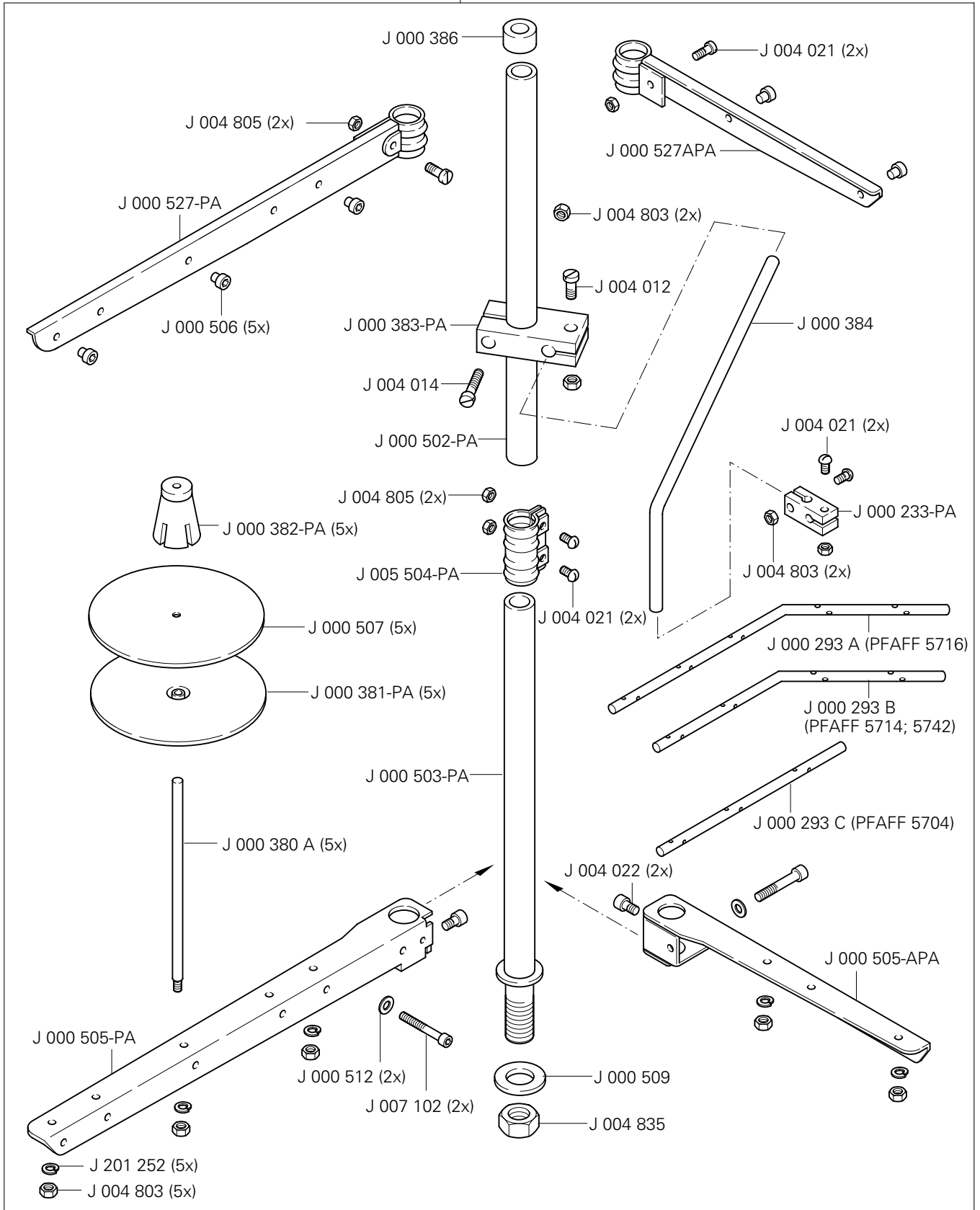

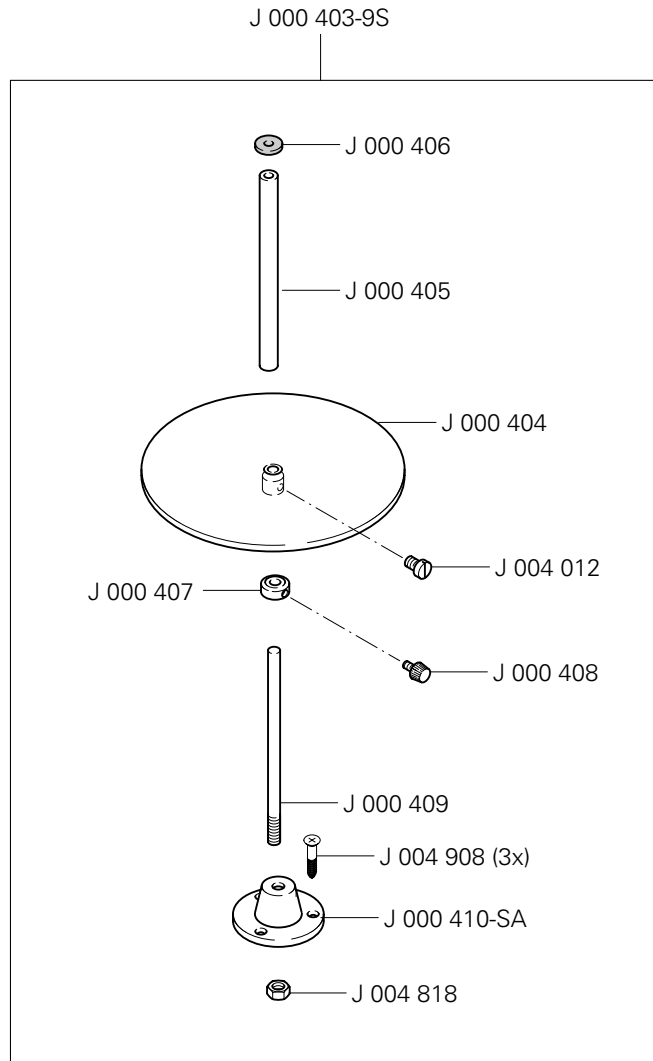
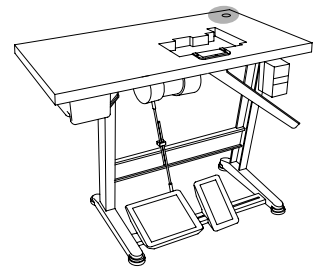

Öl Oil Aceite 油	Mittelpunkts-Viskosität bei: Mean viscosity at: Viscosidad media a: 中点粘度:		Dichte bei: Density of: Densidad a: 密度, 在:		Bestellnummer für Behälter mit: Part number for can with: Número de pedido para recipientes con: 订货号用于油箱, 带:		
	°C	mm <sup>2</sup> /s	°C	g/cm <sup>3</sup> (g/ml)	1 Liter 1 Litre 1 Litro 1 升	5 Liter 5 Litre 5 Litros 5 升	10 Liter 10 Litre 10 Litros 10 升
28-011 201-44	40	22,0	15	0,865	91-129 917-91	91-129 919-91	91-129 920-91

Fett Grease Grasa 脂	Penetration Penetration Penetración 贯入度	Tropfpunkt Drip-point Punto de goteo 贯入度	Bestellnummer für Behälter mit: Part number for can with: Número de pedido para recipientes con: 订货号用于油箱, 带:		
	mm/10	°C	0,25 kg	0,5 kg	1 kg
28-011 202-47	220-250	185			28-011 202-47

Reinigungsmittel Cleansing agent Limpiadores 清洁剂	Bestellnummer für Behälter mit: Part number for can with: Número de pedido para recipientes con: 订货号用于油箱, 带:
Isoprophyl-Alkohol 异丙醇	240 ml 95-665 735-91

No. 零件号	Seite Page Página 页号	No. 零件号	Seite Page Página 页号	No. 零件号	Seite Page Página 页号	No. 零件号	Seite Page Página 页号
JBGA 300	3 - 1	J 001 175-2	10 - 3	J 004 805	7 - 1, 10 - 2, 15 - 1	J 007 014	11 - 1
JPS-280050	14 - 1	J 001 175-3	10 - 3	J 004 806	4 - 3	J 007 017	3 - 3, 4 - 5, 13 - 1
J 000 233-PA	15 - 1	J 001 175-3	4 - 4	J 004 818	15 - 2	J 007 018	3 - 1, 3 - 2, 4 - 4, 5 - 1, 12 - 1
J 000 293A	15 - 1	J 001 189	10 - 3, 12 - 3	J 004 821	3 - 3	J 007 019	3 - 1, 3 - 2, 3 - 3, 4 - 4, 4 - 5, 6 - 1, 9 - 2, 10 - 3, 11 - 1
J 000 293B	15 - 1	J 001 459	8 - 1	J 004 832	4 - 3	J 007 020	3 - 1, 3 - 2, 4 - 5, 6 - 1, 7 - 1, 8 - 2, 9 - 2, 11 - 1
J 000 293C	15 - 1	J 001 998-2	12 - 1	J 004 835	15 - 1	J 007 021	3 - 3, 4 - 5, 9 - 2, 10 - 1
J 000 380A	15 - 1	J 002 193	9 - 2	J 004 904	14 - 1	J 007 023A	3 - 3, 5 - 1, 9 - 1, 12 - 1, 12 - 2, 13 - 1
J 000 381-PA	15 - 1	J 002 902	9 - 1	J 004 905	14 - 1	J 007 024	3 - 1
J 000 382-PA	15 - 1	J 002 918	11 - 1	J 004 908	15 - 2	J 007 025	3 - 2
J 000 383-PA	15 - 1	J 004 009-1HC	11 - 1	J 005 029	11 - 1	J 007 032	11 - 1
J 000 384	15 - 1	J 004 012	15 - 1, 15 - 2	J 005 082A	4 - 1	J 007 033	4 - 4
J 000 386	15 - 1	J 004 014	15 - 1	J 005 088	9 - 1	J 007 038	10 - 2
J 000 403-9S	15 - 2	J 004 021	15 - 1	J 005 117	4 - 3	J 007 039	12 - 1
J 000 404	15 - 2	J 004 022	15 - 1	J 005 138B	3 - 1	J 007 041	9 - 2, 10 - 3
J 000 405	15 - 2	J 004 510	3 - 2	J 005 231	10 - 3	J 007 044	3 - 2
J 000 406	15 - 2	J 004 514	8 - 1, 8 - 2, 10 - 2, 12 - 3, 13 - 1	J 005 292-HU	5 - 1	J 007 052	4 - 3
J 000 407	15 - 2	J 004 523	8 - 2	J 005 304	8 - 1	J 007 058	10 - 1
J 000 408	15 - 2	J 004 529	13 - 1	J 005 315	11 - 1	J 007 059	10 - 1
J 000 409	15 - 2	J 004 531	3 - 1	J 005 328	12 - 3	J 007 060	7 - 1
J 000410-SA	15 - 2	J 004 533	5 - 1, 9 - 1, 10 - 1, 10 - 2, 12 - 3	J 005 336	11 - 1	J 007 062	3 - 3
J 000 486A9P	15 - 1	J 004 534	7 - 1	J 005 484-HC	11 - 1	J 007 066	3 - 2, 3 - 3, 4 - 5
J 000 486B9P	15 - 1	J 004 535	10 - 2, 12 - 3	J 005 492	10 - 3	J 007 077	3 - 3
J 000 486C9P	15 - 1	J 004 538	5 - 1, 9 - 1, 10 - 2	J 005 501	11 - 1	J 007 082	3 - 3, 4 - 4
J 000 502-PA	15 - 1	J 004 541	8 - 1, 8 - 2	J 005 504-PA	15 - 1	J 007 084	3 - 1, 3 - 2
J 000 503-PA	15 - 1	J 004 543	3 - 2, 3 - 3, 4 - 5, 5 - 1, 10 - 3, 12 - 1	J 005 505-APA	15 - 1	J 007 099	4 - 3
J 000 505-APA	15 - 1	J 004 545	5 - 1, 12 - 1	J 005 505-PA	15 - 1	J 007 102	15 - 1
J 000 505-PA	15 - 1	J 004 554	4 - 5	J 005 536	9 - 2	J 007 119	9 - 2
J 000 506	15 - 1	J 004 556	8 - 2	J 005 605	9 - 2	J 007 130	7 - 1
J 000 507	15 - 1	J 004 575	14 - 1	J 007 008	3 - 2, 4 - 4, 4 - 5, 7 - 1	J 007 150	5 - 1, 12 - 1, 12 - 2, 12 - 3
J 000 509	15 - 1	J 004 594	7 - 1	J 007 009	3 - 3, 7 - 1, 10 - 3		
J 000 512	15 - 1	J 004 800	13 - 1	J 007 010	4 - 4, 11 - 1		
J 000 527-APA	15 - 1	J 004 803	15 - 1	J 007 011	10 - 1, 13 - 1		
J 000 527PA	15 - 1			J 007 012	11 - 1, 13 - 1		
				J 007 013	5 - 1, 8 - 1, 9 - 1		

No. 零件号	Seite Page Página 页号	No. 零件号	Seite Page Página 页号	No. 零件号	Seite Page Página 页号	No. 零件号	Seite Page Página 页号
J 007 161	10 - 1	J 201 477	14 - 1	J 204 638	9 - 1	J 208 448	4 - 1
J 007 164	4 - 3	J 202 175	6 - 1	J 204 659	11 - 1	J 208 449	4 - 1
J 007 167	4 - 5	J 202 199	13 - 1	J 204 810	10 - 3	J 208 450-UA001	4 - 2
J 007 170	4 - 1	J 202 287A	3 - 1	J 205 061	5 - 1, 10 - 2	J 208 450-UA002	4 - 2
J 007 171	7 - 1	J 202 295	9 - 2	J 205 113A	13 - 1	J 208 450-UA003	4 - 2
J 007 172	3 - 2	J 202 433	4 - 3	J 205 319	9 - 1	J 208 450-UA004	4 - 2
J 007 174	12 - 1, 12 - 2	J 202 451	7 - 1	J 205 466	14 - 1	J 208 476	8 - 2
J 007 175	7 - 1	J 202 495	4 - 4	J 205 468-PA	14 - 1	J 208 549	7 - 1
J 007 176	3 - 1	J 202 522	10 - 2	J 205 469-PA	14 - 1	J 208 569	11 - 1
J 007 180	3 - 3	J 202 527A	9 - 1	J 205 470-PA	14 - 1	J 208 578	9 - 1
J 007 192	5 - 1	J 202 849	4 - 1	J 205 473	14 - 1	J 208 579	9 - 1
J 007 193	4 - 3	J 202 875	3 - 3, 4 - 4, 11 - 1	J 205 584	7 - 1	J 208 627	8 - 1
J 007 267	11 - 1	J 204 018	8 - 2	J 205 857	10 - 3	J 208 696A	9 - 1
J 007 365	4 - 4	J 204 019A	8 - 2	J 206 115	4 - 5	J 208 773	7 - 1
J 007 366	4 - 4	J 204 042	11 - 1	J 206 457	3 - 1	J 208 777	4 - 4
J 007 367	4 - 4	J 204 072	12 - 2	J 206 682	3 - 1	J 208 778	4 - 4
J 007 369	12 - 1, 12 - 2	J 204 111A	10 - 3	J 208 109	10 - 3	J 208 851	9 - 2
J 007 372	4 - 3	J 204 114	10 - 3	J 208 173	3 - 2	J 208 903-C	5 - 1
J 045 43	7 - 1	J 204 115	10 - 3	J 208 194	12 - 3	J 208 935	11 - 1
J 045 72	8 - 1	J 204 122	10 - 3	J 208 195	12 - 3	J 208 949	3 - 1
J 137 108	4 - 5	J 204 123A	10 - 3	J 208 235	9 - 1	J 209 007-91	12 - 2
J 137 142	11 - 1	J 204 124	10 - 3	J 208 250	5 - 1	J 209 009	11 - 1
J 179 130-05	12 - 1	J 204 140A	10 - 1	J 208 259	12 - 2	J 209 068	4 - 4
J 179 136A91	12 - 1	J 204 143A	10 - 1	J 208 272	8 - 2	J 209 083	12 - 2
J 179 498-92	4 - 5	J 204 158	9 - 2	J 208 356	11 - 1	J 209 084	3 - 2, 12 - 2
J 179 765-15	4 - 3	J 204 161	9 - 2	J 208 357	11 - 1	J 209 408	13 - 1
J 200 020	10 - 2	J 204 185	10 - 1	J 208 358	11 - 1	J 209 409	13 - 1
J 200 041	4 - 4	J 204 439A	10 - 3	J 208 393	9 - 2	J 209 410	13 - 1
J 200 041A	4 - 4	J 204 466	6 - 1	J 208 402	9 - 1	J 209 452	7 - 1
J 200 136	13 - 1	J 204 536	11 - 1	J 208 425	5 - 1	J 209 458	7 - 1
J 200 155	6 - 1	J 204 631	11 - 1	J 208 447-UA001	4 - 2	J 209 471	7 - 1
J 201 121A	9 - 1	J 204 631A	11 - 1	J 208 447-UA002	4 - 2	J 209 472	7 - 1
J 201 252	3 - 2, 15 - 1	J 204 636B	11 - 1	J 208 447-UA003	4 - 2	J 209 481	8 - 2

No. 零件号	Seite Page Página 页号	No. 零件号	Seite Page Página 页号	No. 零件号	Seite Page Página 页号	No. 零件号	Seite Page Página 页号
J 209 512-PD	3 - 1	J 209 569-92	12 - 3	J 209 609	3 - 2	J 209 645	3 - 3
J 209 513-PD	3 - 3	J 209 570-92	10 - 1	J 209 610-91	13 - 1	J 209 646	5 - 1
J 209 515-PD	3 - 3	J 209 571-91	3 - 2	J 209 612-D	13 - 1	J 209 647	5 - 1
J 209 516	3 - 3	J 209 574-91	3 - 2	J 209 613-D	8 - 2	J 209 648	5 - 1
J 209 517	3 - 1	J 209 574B91	3 - 2	J 209 614	6 - 1	J 209 649	10 - 1
J 209 518	3 - 3	J 209 576-91	3 - 2	J 209 615	6 - 1	J 209 650	10 - 1
J 209 518A	3 - 3	J 209 578	3 - 1	J 209 616	6 - 1	J 209 651	3 - 3
J 209 519	10 - 3	J 209 579	3 - 1	J 209 617	6 - 1	J 209 652	7 - 1
J 209 539	11 - 1	J 209 581	8 - 1	J 209 618	3 - 3	J 209 653	12 - 1
J 209 540	11 - 1	J 209 582	5 - 1	J 209 619	3 - 3	J 209 654	13 - 1
J 209 541	11 - 1	J 209 583	12 - 1, 12 - 2	J 209 620	4 - 1	J 209 656	13 - 1
J 209 542	9 - 2	J 209 583A	12 - 2	J 209 621	4 - 4	J 209 657	3 - 1
J 209 542A	9 - 2	J 209 584	10 - 2	J 209 622	4 - 1	J 209 658	13 - 1
J 209 543	3 - 3	J 209 585	12 - 3	J 209 623	4 - 4	J 209 660	12 - 1, 12 - 2
J 209 544-92	5 - 1	J 209 586	12 - 3	J 209 624	4 - 4	J 209 661	6 - 1
J 209 545-92	9 - 1	J 209 587-91	12 - 1	J 209 625	4 - 4	J 209 662	6 - 1
J 209 546-92	12 - 1, 12 - 2	J 209 589	3 - 2	J 209 626	4 - 4	J 209 663	6 - 1
J 209 547-PB	3 - 2	J 209 590	12 - 1	J 209 627	6 - 1	J 209 663A	6 - 1
J 209 548-PB	3 - 2	J 209 591-91	8 - 1	J 209 628	4 - 4	J 209 664	3 - 3
J 209 550-PB	3 - 1	J 209 592-91	10 - 2	J 209 629	4 - 4	J 209 665	3 - 3
J 209 551	3 - 1	J 209 594	10 - 2	J 209 630	4 - 5	J 209 666	9 - 2
J 209 552-92	5 - 1	J 209 595	10 - 3	J 209 631	4 - 5	J 209 667	9 - 2
J 209 553-92	5 - 1	J 209 596	7 - 1	J 209 633	3 - 2	J 209 668	11 - 1
J 209 554-92	5 - 1, 9 - 1	J 209 597	7 - 1	J 209 634	3 - 2	J 209 669	11 - 1
J 209 555-92	10 - 2	J 209 598	9 - 1	J 209 636	3 - 3	J 209 669A	11 - 1
J 209 556-91	10 - 1	J 209 599	12 - 3	J 209 637	8 - 1	J 209 671-92	8 - 1
J 209 560-92	12 - 1, 12 - 2	J 209 600	12 - 3	J 209 638	7 - 1	J 209 672	10 - 3
J 209 562-92	12 - 1, 12 - 2	J 209 601	12 - 3	J 209 639	10 - 2	J 209 673	10 - 3
J 209 563-92	12 - 2	J 209 602	12 - 3	J 209 640	5 - 1	J 209 674	9 - 1
J 209 564-92	10 - 2	J 209 603-91	7 - 1	J 209 641	3 - 3	J 209 675	9 - 1
J 209 566-92	5 - 1	J 209 606	8 - 2	J 209 642	5 - 1	J 209 676	7 - 1
J 209 567-92	5 - 1	J 209 607	8 - 2	J 209 643	6 - 1	J 209 677	10 - 2
J 209 568-92	12 - 1	J 209 608	3 - 2	J 209 644	3 - 3	J 209 678	7 - 1

No. 零件号	Seite Page Página 页号	No. 零件号	Seite Page Página 页号	No. 零件号	Seite Page Página 页号	No. 零件号	Seite Page Página 页号
J 209 679	4 - 4	J 210 353	4 - 4	J 240 343	3 - 2	J 274 006	7 - 1
J 209 680	3 - 3	J 210 529-9U001	4 - 1, 4 - 2	J 240 436	10 - 2	J 274 013	7 - 1
J 209 681	4 - 4	J 210 529-9U002	4 - 1, 4 - 2	J 240 484	10 - 2	J 274 016A	7 - 1
J 209 683	4 - 4	J 210 530-9U003	4 - 1, 4 - 2	J 240 517	10 - 2	J 274 017	7 - 1
J 209 684	4 - 4	J 210 531-9U004	4 - 1, 4 - 2	J 240 537	5 - 1	J 274 586	13 - 1
J 209 685	12 - 3	J 210 586A	12 - 1, 12 - 2, 12 - 3	J 240 551	8 - 2	J 274 592	13 - 1
J 209 685-HC	12 - 3	J 210 717	10 - 2	J 240 552	8 - 2	J 275 033A	4 - 5
J 209 686-91	8 - 1	J 210 766	6 - 1	J 240 564	3 - 2	J 275 034	4 - 5
J 209 686A91	8 - 1	J 210 930	11 - 1	J 240 565	14 - 1	J 275 035	4 - 5
J 209 687	3 - 1	J 211 301	10 - 1	J 240 566	13 - 1	J 275 036	4 - 5
J 209 688-91	3 - 1	J 211 388	4 - 5	J 240 570	4 - 3	J 275 037	4 - 5
J 209 689-92	12 - 3	J 212 435	4 - 3	J 240 571	9 - 2	J 275 039	4 - 5
J 209 690-91	5 - 1	J 212 436	4 - 3	J 252 069A	10 - 1	J 275 522	4 - 3
J 209 693	4 - 3	J 212 978-91	13 - 1	J 270 018A	3 - 3	J 303 067	12 - 1, 12 - 2
J 209 697	6 - 1	J 212 981	13 - 1	J 270 042	3 - 2	J 303 448	6 - 1
J 209 699	4 - 5	J 212 982A	13 - 1	J 270 043	3 - 2	J 304 305	4 - 3
J 209 703-91	12 - 1	J 240 043	3 - 3	J 270 044	3 - 2	J 304 306	4 - 3
J 209 714	11 - 1	J 240 062	10 - 2	J 270 045	3 - 2	J 304 307	4 - 3
J 209 715	4 - 5	J 240 104	4 - 3	J 270 047	3 - 1	J 304 315	4 - 3
J 209 716-PD	8 - 2	J 240 129	5 - 1	J 270 048	3 - 2	J 304 316	4 - 3
J 209 720	4 - 4	J 240 178	6 - 1	J 270 049	3 - 3	J 304 318	4 - 3
J 209 722	3 - 2	J 240 190	5 - 1	J 270 510	8 - 1	J 308 088	9 - 2
J 209 723	11 - 1	J 240 293	8 - 2	J 270 526	8 - 2	J 308 243-9	3 - 1
J 209 724-92	12 - 3	J 240 301	3 - 3	J 271 001	5 - 1, 9 - 1, 10 - 2	J 308 244	3 - 1
J 209 729	12 - 3	J 240 304	14 - 1	J 271 519	12 - 1	J 308 332A	9 - 2
J 209 735	4 - 1	J 240 305	3 - 2, 3 - 3, 11 - 1	J 272 502	10 - 2	J 308 333	9 - 2
J 209 743	8 - 2	J 240 310	3 - 2	J 272 503	10 - 2	J 308 334A	9 - 2
J 210 044	3 - 3	J 240 311	5 - 1, 10 - 2	J 272 504-91	10 - 2	J 308 490	9 - 2
J 210 129	10 - 2	J 240 315	4 - 4	J 272 533A	10 - 1	28-011 201-44	16 - 1
J 210 130	10 - 2	J 240 325	4 - 4	J 272 534	10 - 1	28-011 202-47	16 - 1
J 210 184	9 - 2	J 240 328	13 - 1	J 273 504	12 - 3	91-129 917-91	16 - 1
J 210 214	6 - 1, 12 - 1	J 240 336	3 - 2	J 274 003-92	7 - 1	91-129 919-91	16 - 1
J 210 307	3 - 2, 3 - 3, 4 - 5	J 240 338	12 - 1, 12 - 2	J 274 004	7 - 1	91-129 920-91	16 - 1
J 210 319	4 - 1	J 240 339	3 - 1	J 274 005	7 - 1	95-665 735-91	16 - 1





# PFAFF

5704

5714

Unterklassen-Ausstattung

Subclass parts

Composición de las subclases

子机型-设备

5716

5742

-01

Anwendung  
Application  
Aplicación  
应用

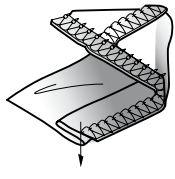

Blindsaum  
Blindstitch hemming  
Doblado invisible  
暗线折缝

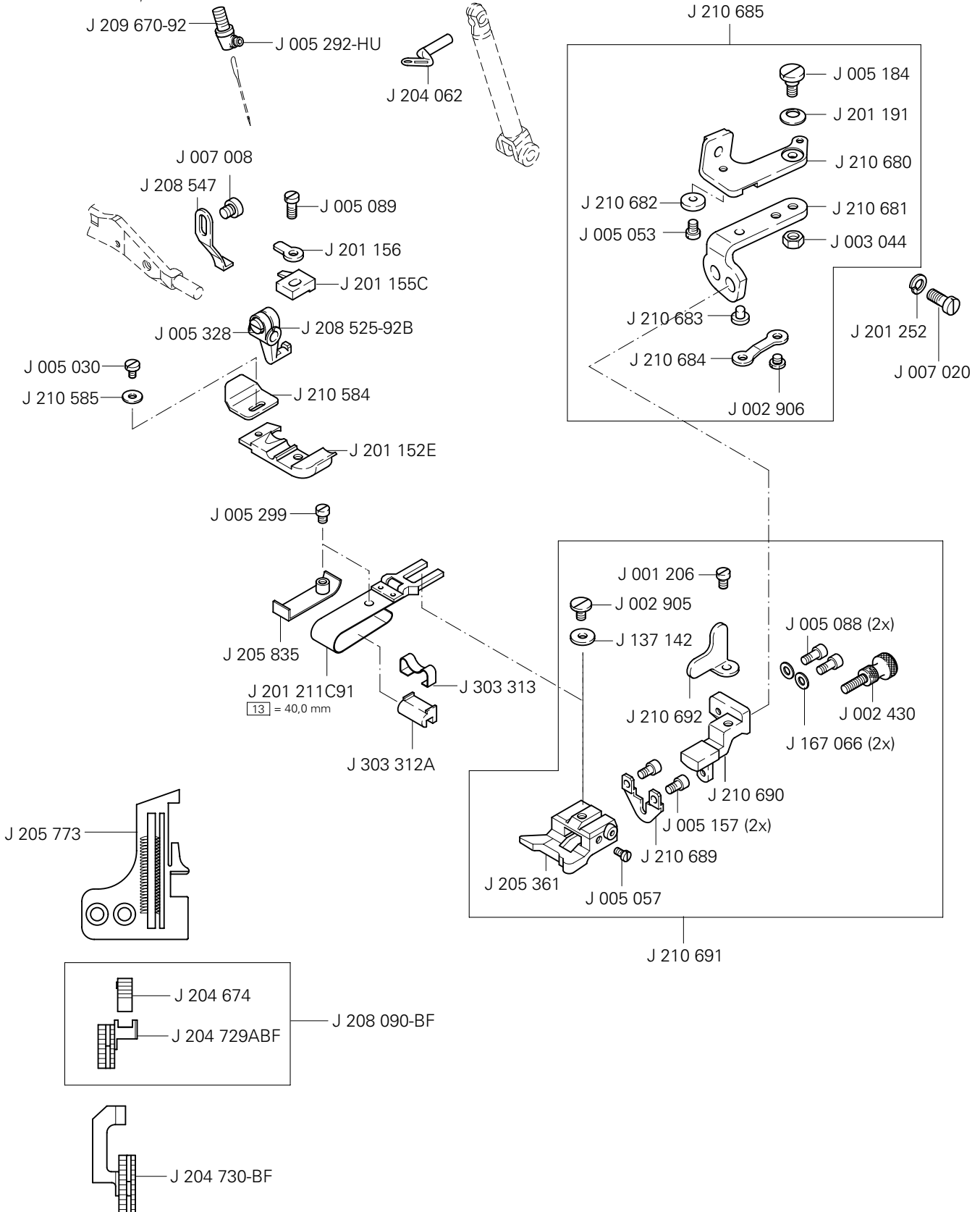

-016S2

Anwendung  
 Application  
 Aplicación  
 应用

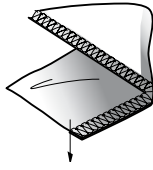

Rollsaum  
 Turn down hemming  
 Dobladillo enrollado  
 折边缝

J 209 670-92



J 005 292-HU

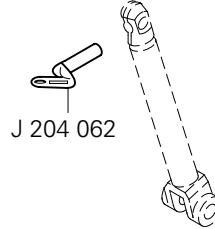

J 204 062

J 007 008

J 208 547

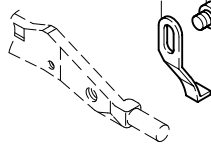

J 005 089

J 201 156

J 205 525

J 005 328



J 208 525-92B

J 005 030



J 001 231

J 211 600



J 201 265B

J 201 230C

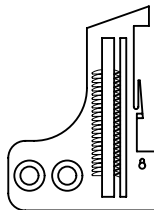
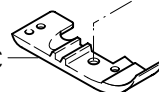

J 205 465

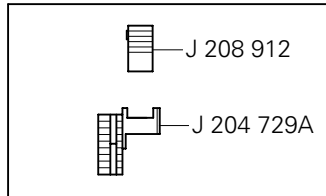

J 208 912

J 204 729A

J 208 911

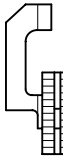

J 204 730

## -17A

Anwendung  
 Application  
 Aplicación  
 应用

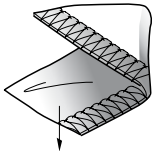

Allgemeine Näharbeiten  
 General work  
 Trabajos de costura en general  
 一般缝纫工作

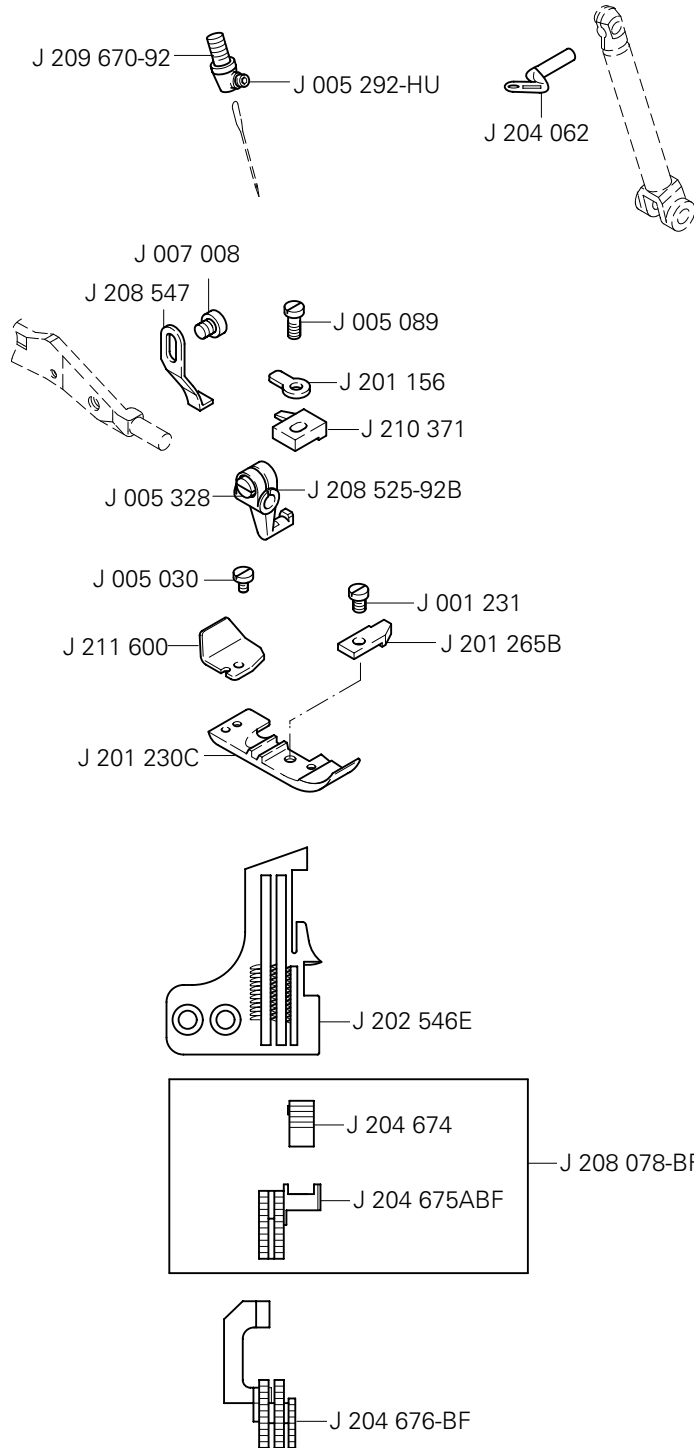

-180

Anwendung  
 Application  
 Aplicación  
 应用

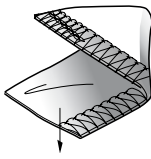

Manuelle Nahtanfangsverriegelung  
 Backlatching  
 Remate manual de costura inicial  
 手动线缝起始锁缝

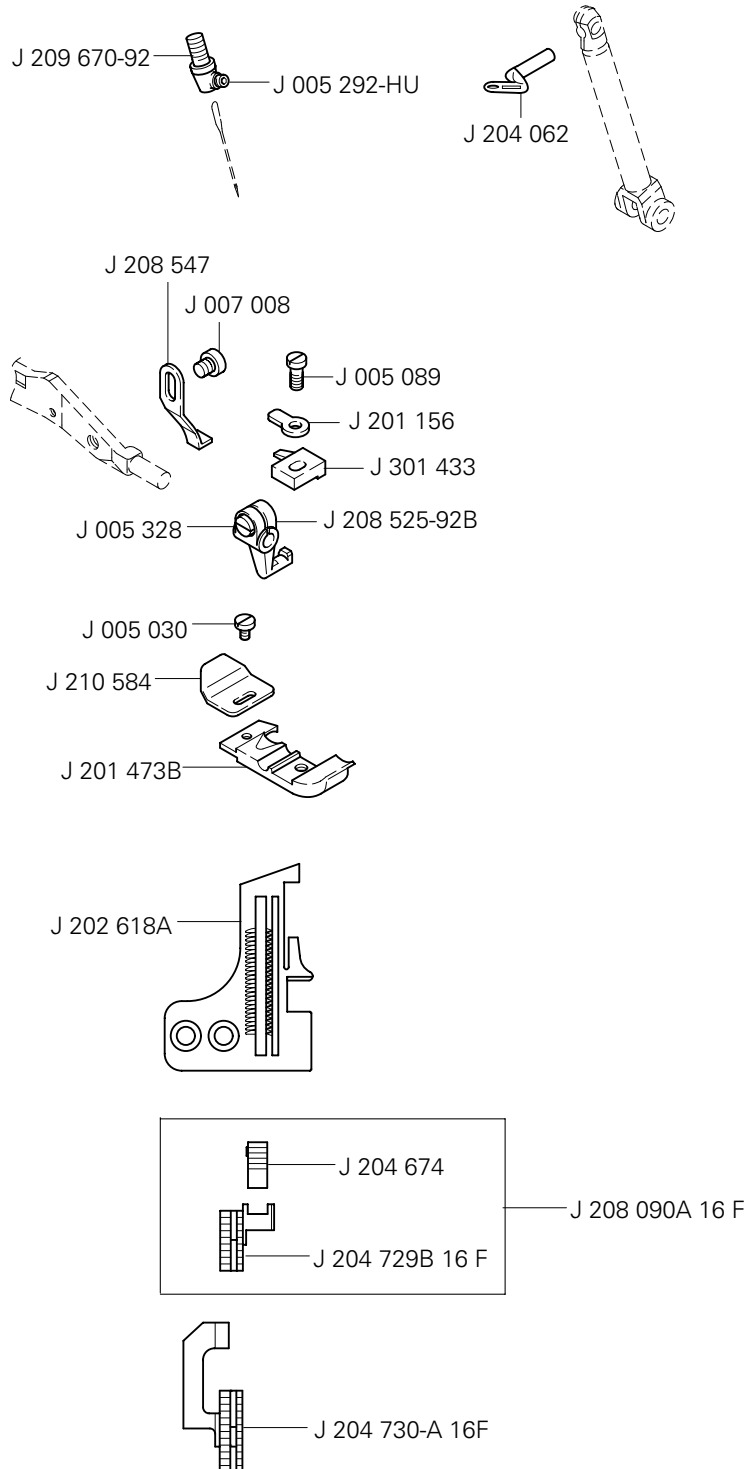

## -13 A

Anwendung  
 Application  
 Aplicación  
 应用

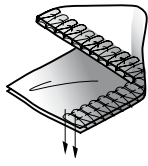

Allgemeine Näharbeiten  
 General work  
 Trabajos de costura en general  
 一般缝纫工作

## -13 H

Anwendung  
 Application  
 Aplicación  
 应用

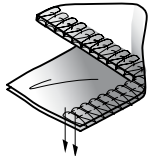

Allgemeine Näharbeiten (schweres Material)  
 General work (heavy material)  
 Trabajos de costura en general (materiales pesados)  
 一般缝纫工作 (厚料)

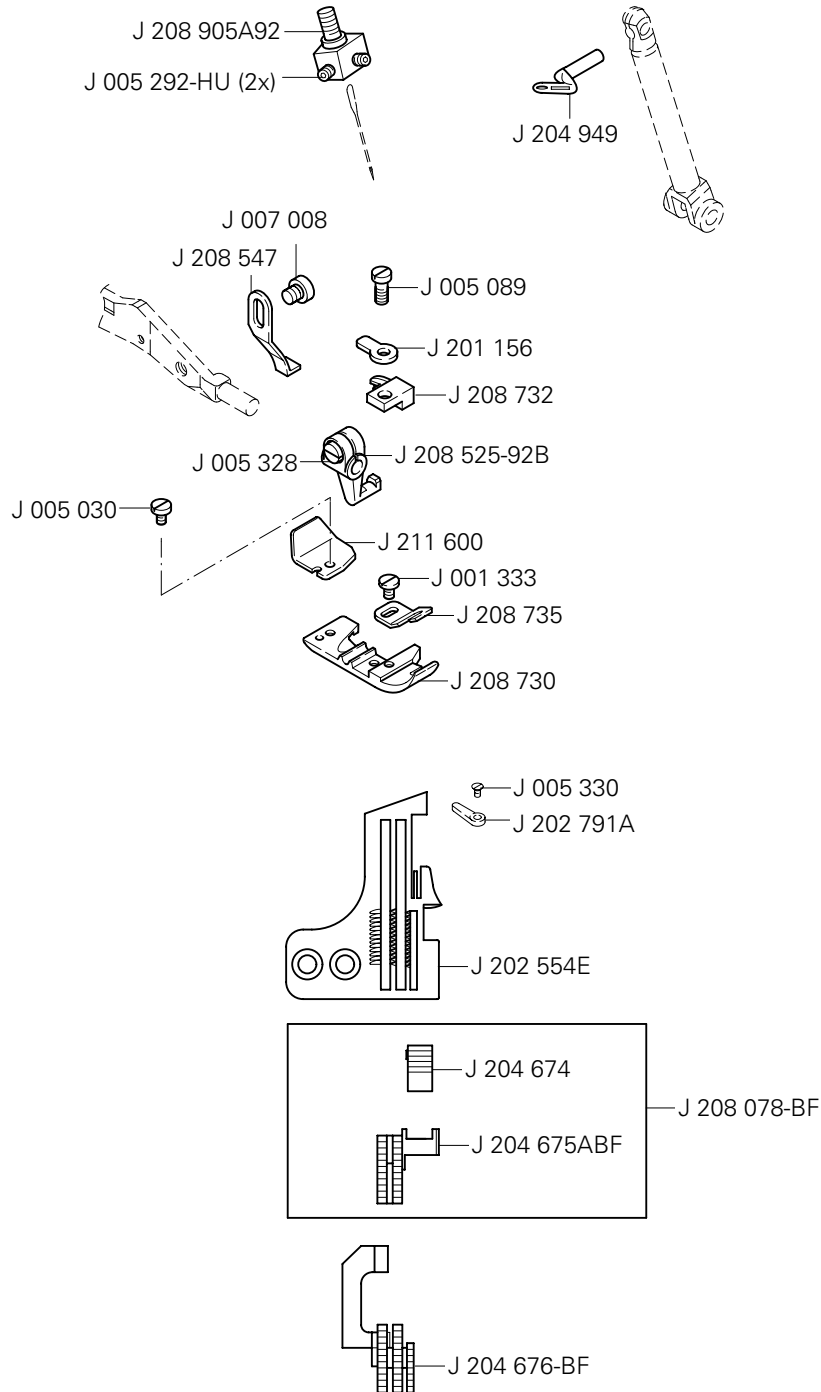

-181

Anwendung  
 Application  
 Aplicación  
 应用

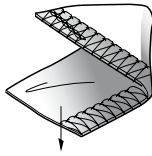

Manuelle Nahtfangsverriegelung  
 Backclatching  
 Remate manual de costura inicial  
 手动线缝起始锁缝

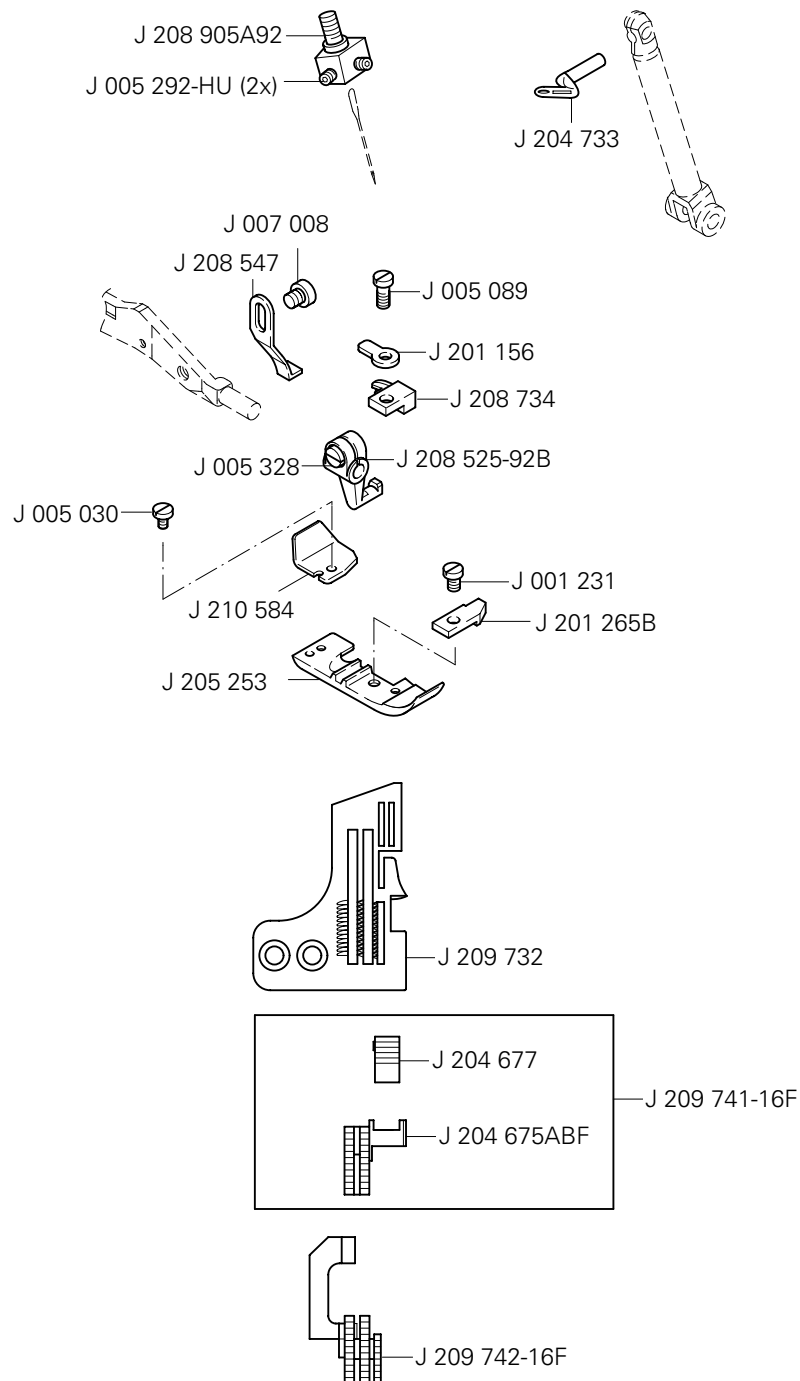

# 18.03

Nähwerkzeuge<sup>▲</sup>  
 Gauge parts  
 Organos de costura  
 缝纫工具

PFAFF 5716

-38A

Anwendung  
 Application  
 Aplicación  
 应用

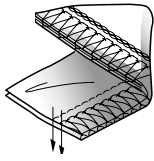

Verbindungsnahte  
 Plain seaming  
 Costuras de unión  
 连接线缝

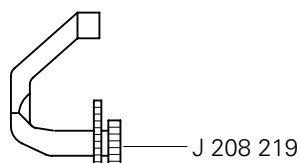
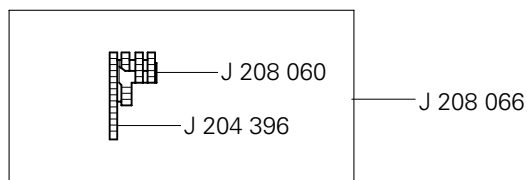
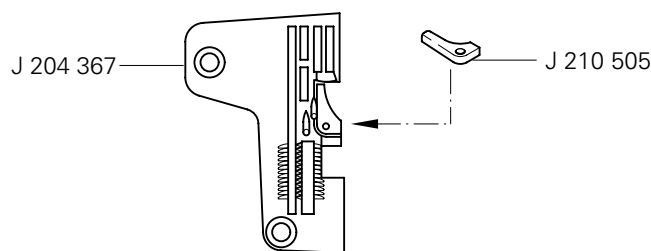
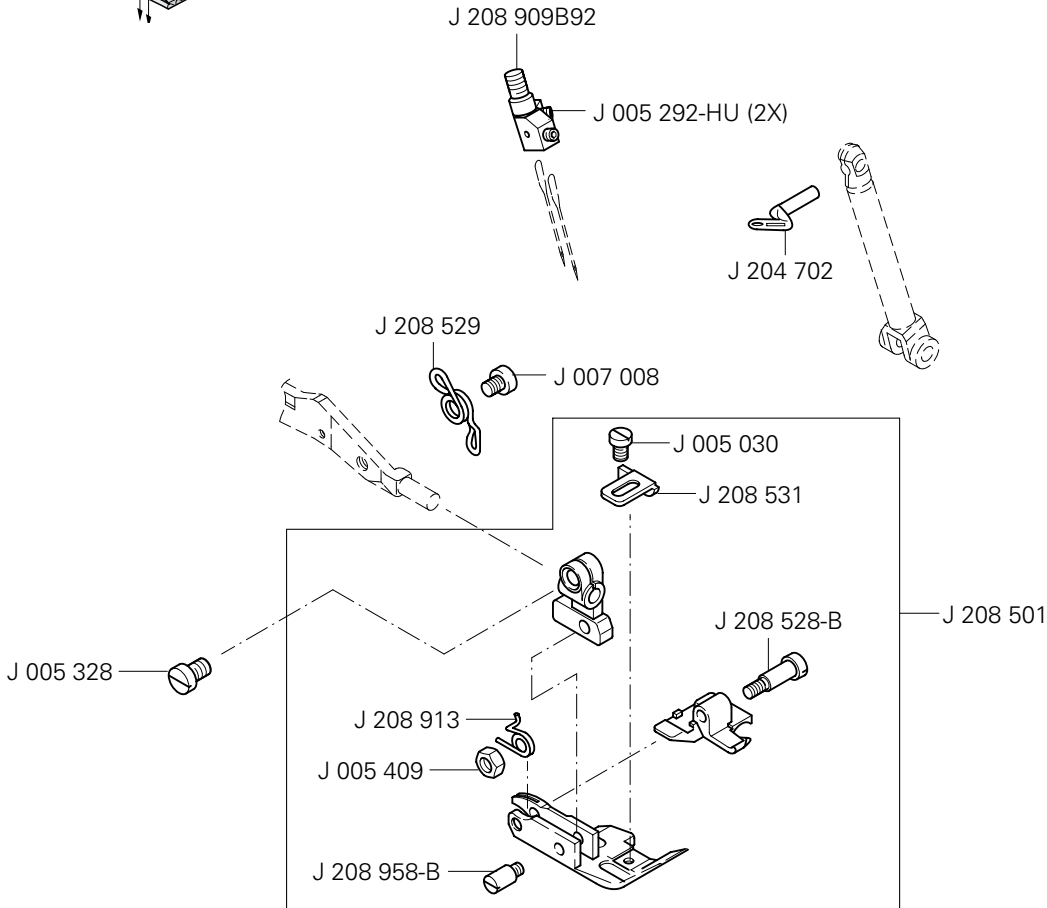



-70A

Anwendung  
 Application  
 Aplicación  
 应用

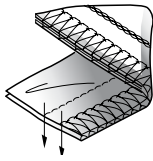

Verbindungsnahte  
 Plain seaming  
 Costuras de unión  
 连接线缝

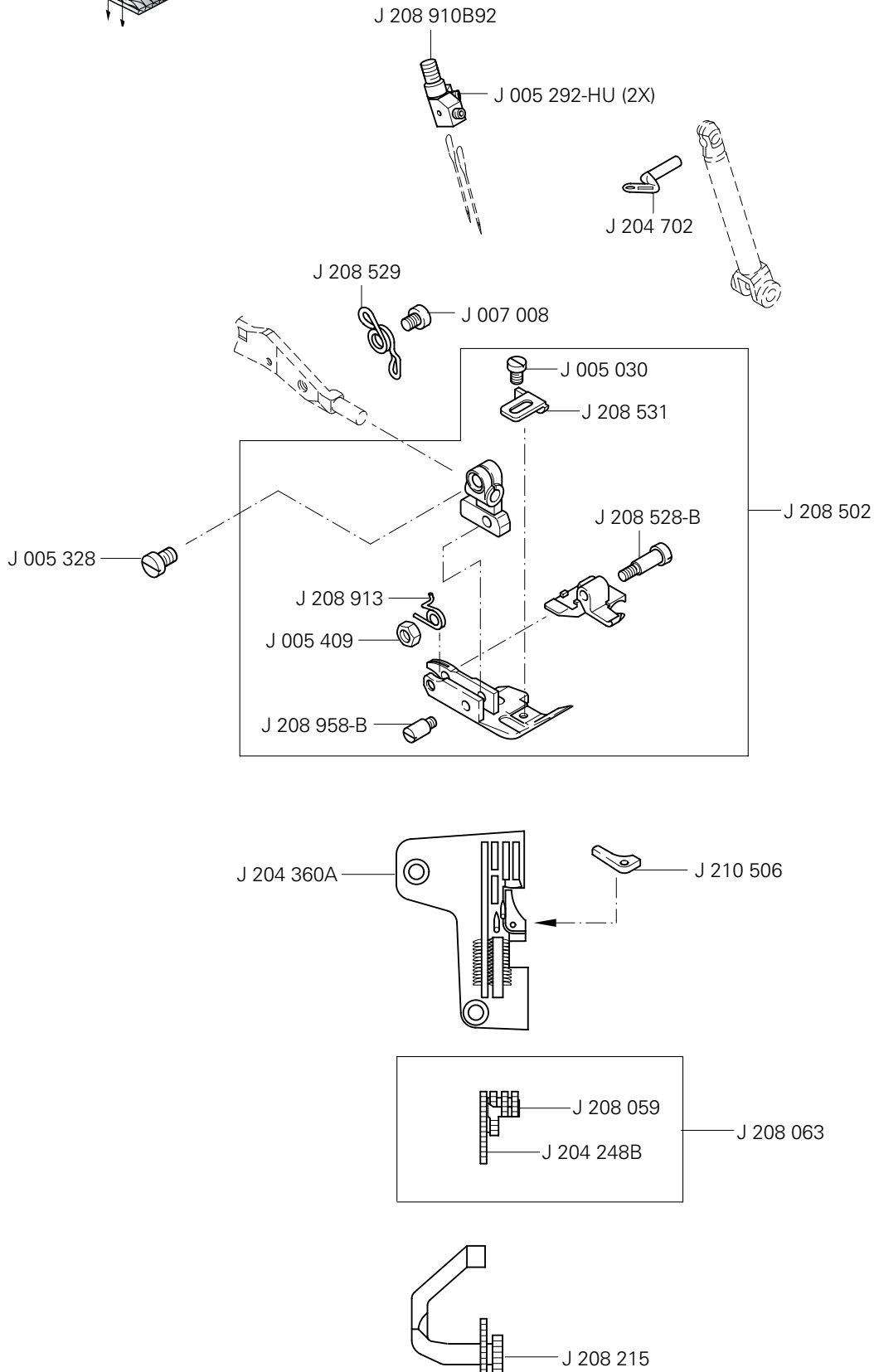

## -86A

Anwendung  
 Application  
 Aplicación  
 应用

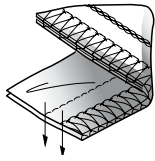

Verbindungsnahte (schweres Material)  
 Plain seaming (heavy material)  
 Costuras de unión (materiales pesados)  
 连接线缝 (厚料)

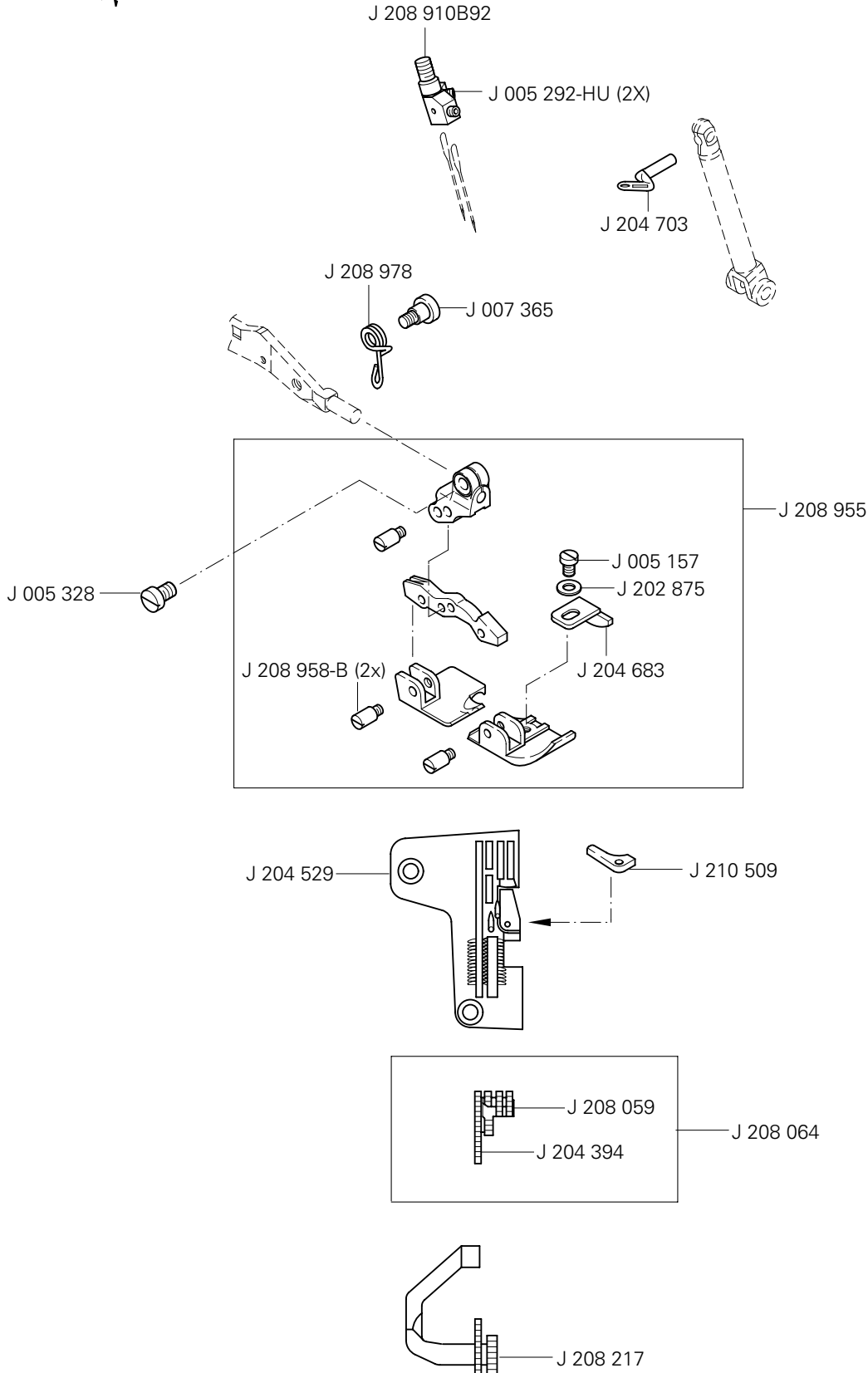

-02-250

Anwendung  
 Application  
 Aplicación  
 应用

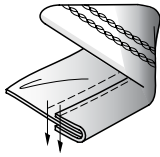

Einfassarbeiten  
 Binding tape  
 Trabajos de ribeteado  
 滚边工作

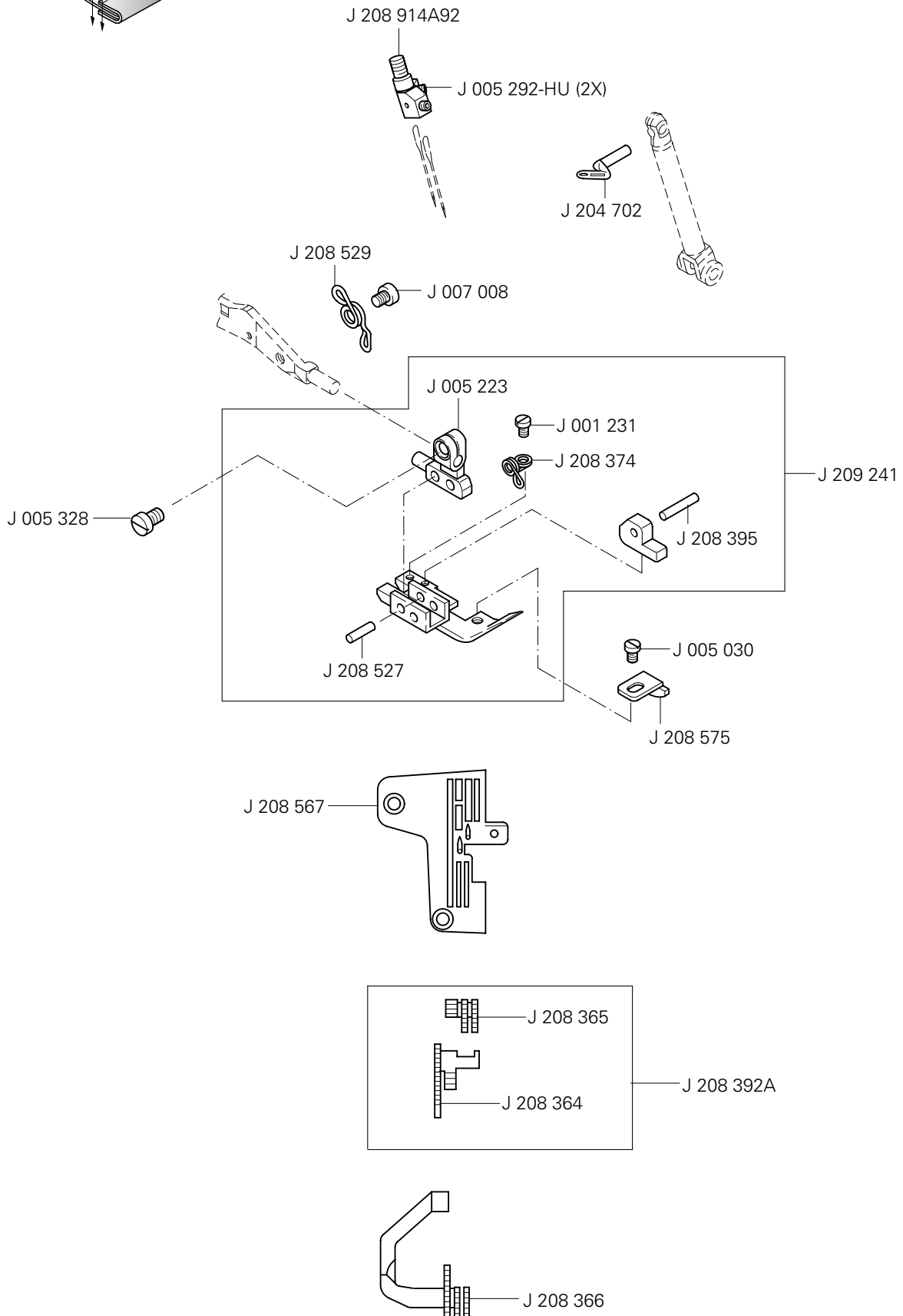

# PFAFF

## PFAFF Industrie Maschinen AG

Postfach 3020  
D-67653 Kaiserslautern

Königstr. 154  
D-67655 Kaiserslautern

Telefon: (0631) 200-0  
Telefax: (0631) 17202  
E-Mail: [info@pfaff-industrial.com](mailto:info@pfaff-industrial.com)