

Sewing Machine Controller

SC-350

PARTS LIST

29296308
No.1179-01

1. SERVO MOTOR COMPONENTS

サーボモーター関係

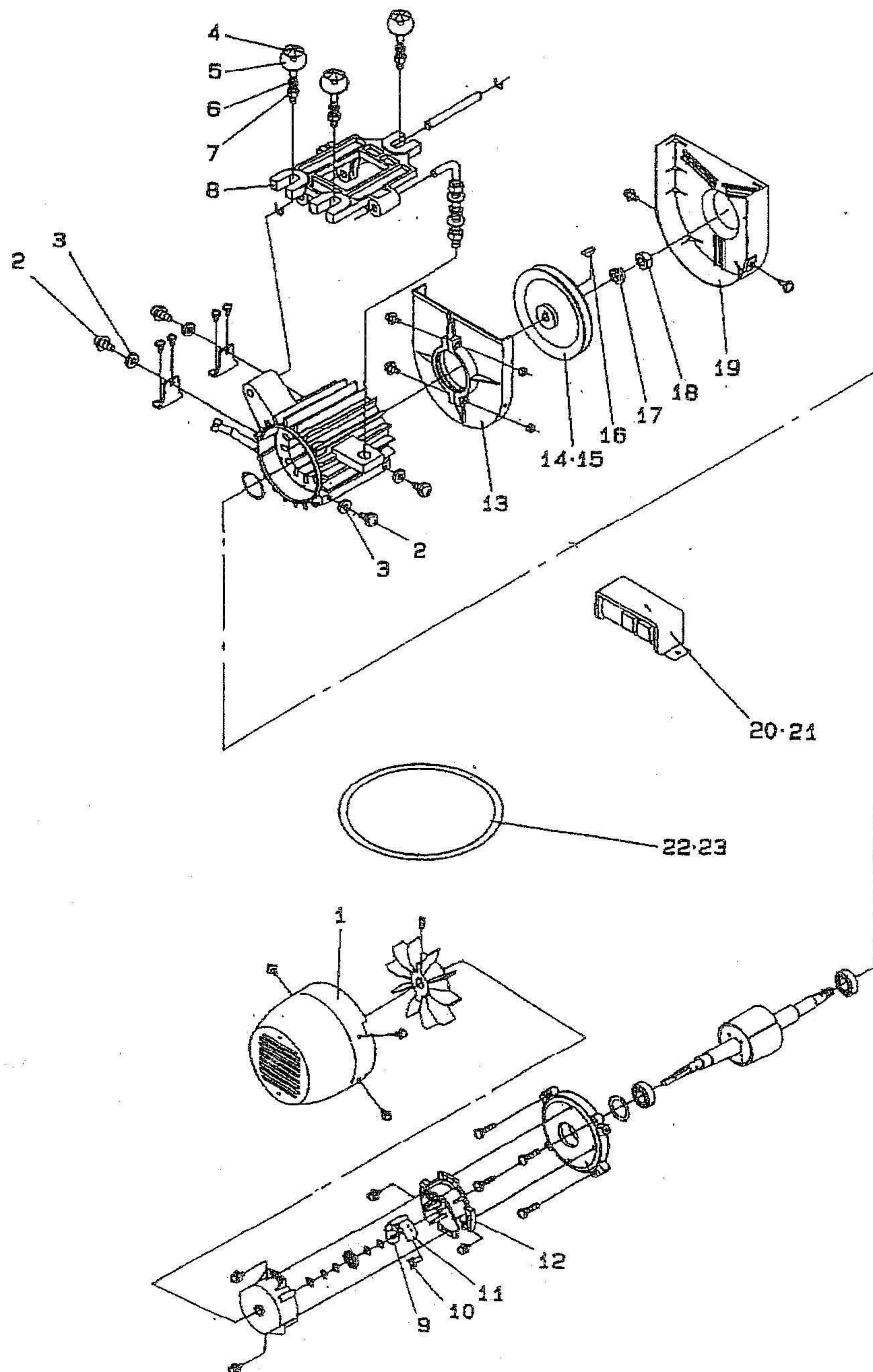

2/4

REF.NO	NOTE	PART NO.	DESCRIPTION	ヒソメイ	Qty
1		MTS-SM820170	END COVER	END COVER	1
2		MTS-SM830160	SCREW+SPRINGW M6*S6*15L	SCREW+SPRINGW M6*S6*15L	4
3		MTS-SM830170	THICKNESS WASHER 3/16"	THICKNESS WASHER 3/16"	4
4		MTS-E8602000	MOUNTING BOLT	トリツケボルト	3
5		MTS-E8605000	WASHER	ワッシャ	3
6		MTS-E8603000	SPRING WASHER	ハネワッシャ	3
7		MTS-E8604000	NUT	ナット	3
8		MTS-SM820200	SLIDE BASE	SLIDE BASE	1
9		MTS-SH8860A0	ENCODER P.C.B (1)	ENCODER P.C.B(1)	3
10		MTS-SM820270	PHOTO SENSOR BASE	PHOTO SENSOR BASE	1
11		MTS-SH8870A0	ENCODER P.C.B (2)	ENCODER P.C.B(2)	1
12		MTS-SM820280	ENCODER BASE	ENCODER BASE	1
13		MTS-E8021022	INSIDE PULLEY COVER	ハトカハ	1
14	#03	MTS-E8110712	MOTOR PULLEY 100	モータプーリ100	1
15	#04	MTS-E8110716	MOTOR PULLEY 120	モータプーリ120	1
16		MTS-SM820300	KEY 4*5*R6.5	KEY 4*5*R6.5	1
17		MTS-SM830310	SPRING WASHER S10	SPRING WASHER S10	1
18		MTS-SM830320	NUT M10*P1.25*8T	NUT M10*P1.25*8T	1
19		MTS-E8021022	OUTSIDE PULLEY COVER	ハトカハ	1
20	#01	MTS-SH862104	POWER SW 1-PHASE 110-240V	POWER SW 1ツウ110-240V	1
21	#02	MTS-SH862105	POWER SW 3-PHASE 220-240V	POWER SW 3ツウ220-240V	1
22	#03	MTS-E8160340	BELT, 40 INCH	ベルト40インチ	1
23	#04	MTS-E8160342	BELT, 42 INCH	ベルト42インチ	1

※ Note (注記) #01....FOR 110V ~ 240V 1 φ
 220V ~ 240V 1 φ
 #02....FOR 220V ~ 240V 3 φ
 #03....FOR 4000SPM, 3300SPM
 #04....FOR 4800SPH, 4500SPM

@ PARTS NUMBER

• SPEED VOLUME

10KΩ

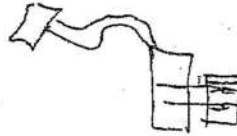

とやあてり 各3ヶ送

• FUSE HOLDER

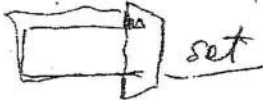

BEFORE NEW ITEM

MTSSB8610A0	→	MTSSB861AA0	TRANSFORMER (220-240V)
MTSSB8810A0	→	MTSSB881AA0	POWER BOADER (1) 220-240V
MTSSB8820A0	→	MTSSB882AA0	POWER BOADER (2) 1φ 220-240V
MTSSB8820AA	→	MTSSB882AAA	POWER BOADER (2) 3φ 220-240V

3/4

2. CONTROL BOX

コントロールボックス関係

MOTOR (5)

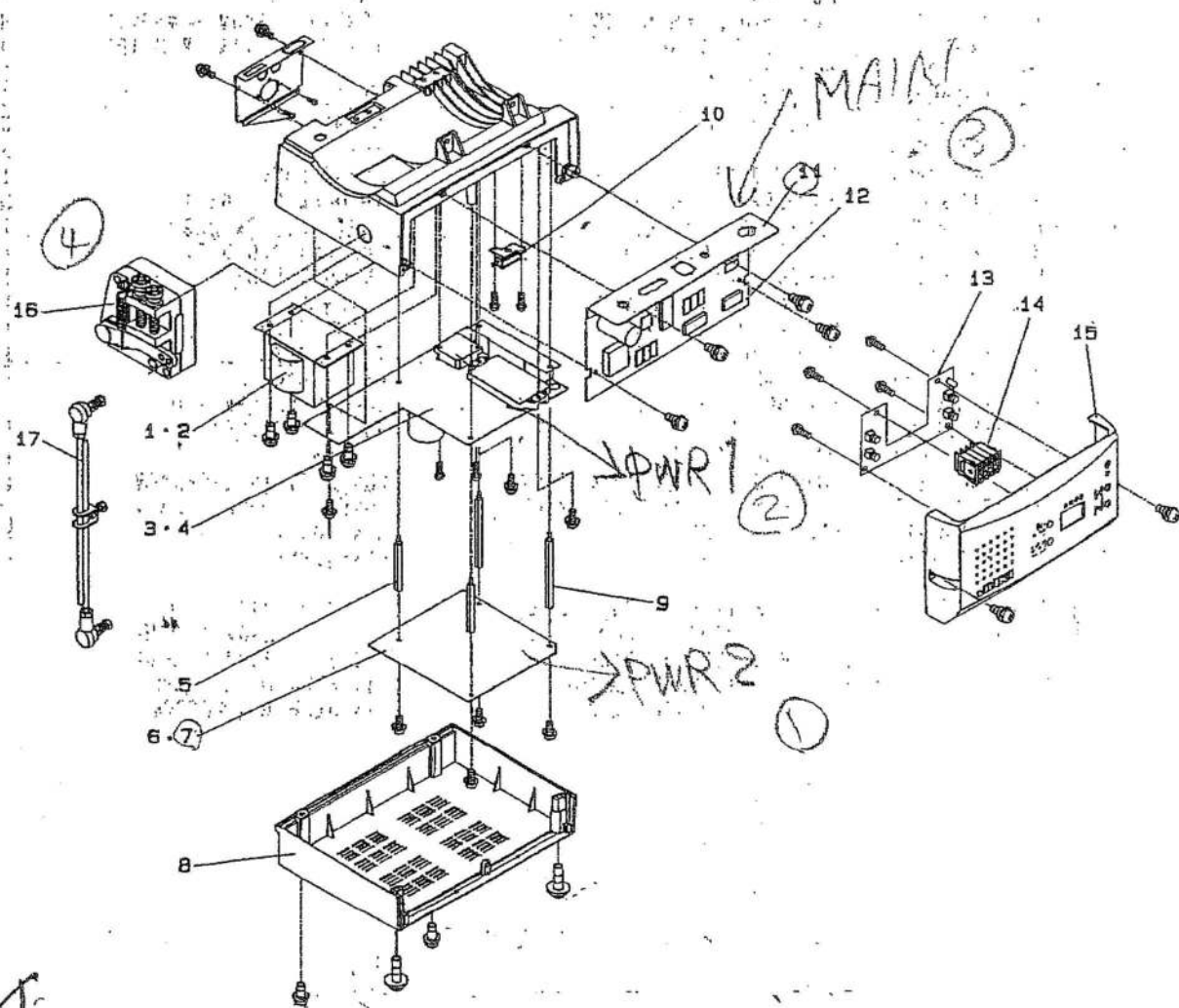

BEFORE

NEW

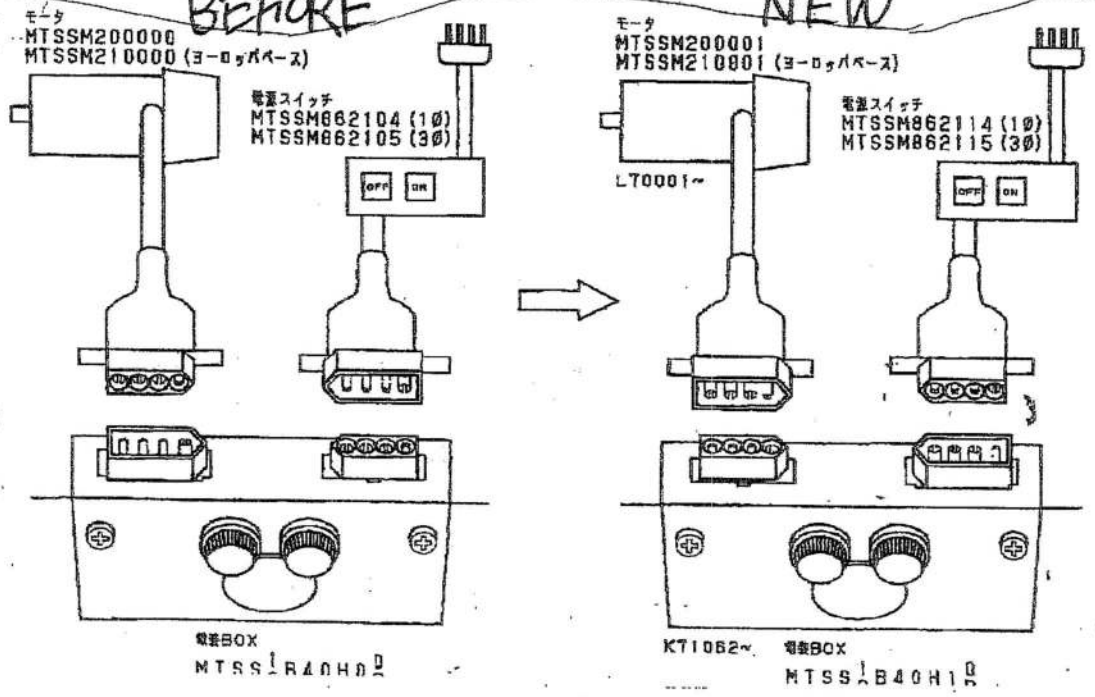

4/4

REF.NO	NOTE	PART NO.	DESCRIPTION	ヒンメイ	Qty
1	#04	MTS-SB8610A0	TRANSFORMER (220-240V)	TRANSFORMER (220-240V)	1
2	#03	MTS-SB8610AA	TRANSFORMER (110-120V)	TRANSFORMER (110-120V)	1
3	#04	MTS-SB8810A0	POWER BOADER (1) 220-240V	POWER BOARD(1) 220-240V	1
4	#03	MTS-SB8810AA	POWER BOADER (1) 110-120V	POWER BOARD(1) 110-120V	1
5		MTS-SB830030	HEXAGEON IRON ROD (1)	HEXAGEON IRON ROD(1)	2
6	#01	MTS-SB8820A0	POWER BOARD (2) 1-PHASE	POWER BOARD(2) 1ツウ	1
7	#02	MTS-SB8820AA	POWER BOARD (2) 3-PHASE	POWER BOARD(2) 3ツウ	1
8		MTS-SB820030	CONTROL BOX LOWER COVER	CONTROL BOX LOWER COVER	1
9		MTS-SB830060	HEXAGEON IRON ROD (2)	HEXAGEON IRON ROD(2)	2
10		MTS-SB8620A0	RADIATOR RESISTOR ASM.	RADIATOR RESISTOR ASM.	1
11		MTS-SB8630A0	OPERATION PANEL	OPERATION PANEL	1
12		MTS-SB8830A0	MASTER P.C.B	MASTER P.C.B	1
13		MTS-SB8840A0	BACKTACK P.C.B	BACKTACK P.C.B	1
14		MTS-SB860050	COUNTER	COUNTER	1
15		MTS-SB820040	FRONT COVER	FRONT COVER	1
16		MTS-SB8860A0	PEDAL SENSOR ASM.	PEDAL SENSOR ASM.	1
17		MTS-SB820330	CONNECTING ROD ASM. (Y)	CONNECTING ROD ASM. (Y)	1

Note (注記) #01...FOR 110V ~ 240V 1 φ
 220V ~ 240V 1 φ
 #02...FOR 220V ~ 240V 3 φ
 #03...FOR 110V ~ 120V 1 φ
 #04...FOR 220V ~ 240V 1 φ
 220V ~ 240V 3 φ

110V ~ 240V 1 φ
 220V ~ 240V 1 φ 用
 220V ~ 240V 3 φ 用
 110V ~ 120V 1 φ 用
 220V ~ 240V 1 φ
 220V ~ 240V 3 φ 用



JUKI 株式会社

JUKI CORPORATION

お問い合わせ、ご相談は
 To order or for further
 information,
 please contact:

※このパーツリストは商品改良のため予告なく変更する事があります。