

ETS32 SERIES

First edition; issued in July, 1984

Second edition; issued in May, 1989

初 版 (1984年 7 月 発行)

第二版 (1989年 5 月 発行)

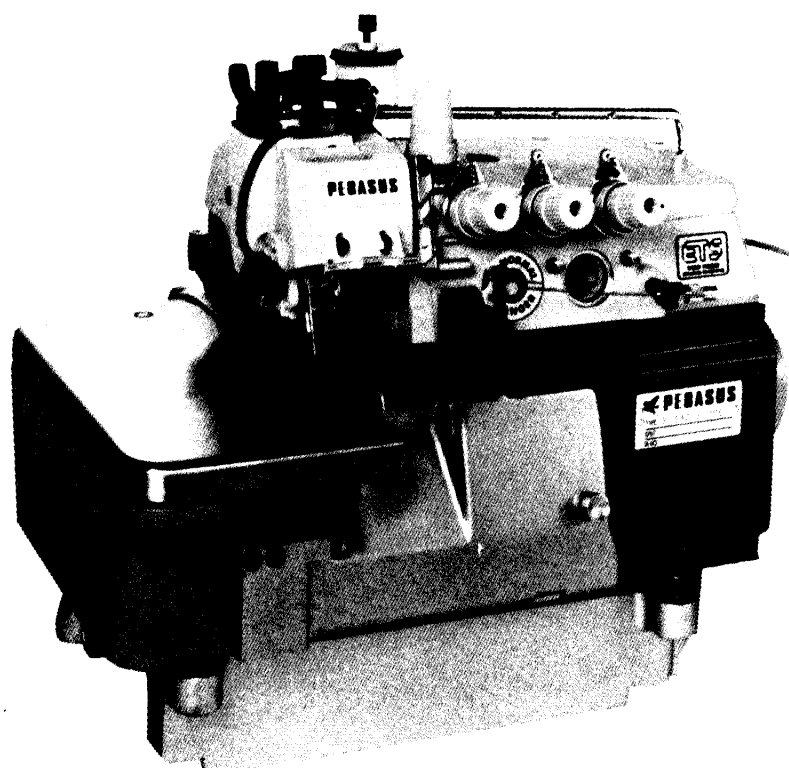

PEGASUS®

Cat. No.	図番△	版数	年 月 日	主 な 改 訂 内 容
8 4 9 7	△	二版	1989. 5. 6.	給油機構の変更 ETS32-355~559(3本針)を追加

Cat. No.	△	Edition	Date.	Modification of the main details
8 4 9 7	△	Second edition	5. 6.1989.	Modification of the Lubrication mechanism. Addition of ETS32-355~559(3-needle).

パーツカタログの見方

- このパーツカタログは、1989年5月製造中のETS32のミシンを次の要領で編集しています。
- 2～57頁には部品を機構別に収録し、左頁が部品の分解図、右頁がパーツリストになっています。
また、部品分解図に付されている番号は、パーツリストのREF.NO.(参照番号)を示しています。
- ゲージパーツ系列構成図・ゲージパーツ表(58～102頁)
これらの部品は、特定の形式にのみ使用されている部品で、系列構成図は58～93頁に、ゲージパーツ表は94～102頁に一括して記載しています。
- 104～107頁には部品番号インデックスを記載し、部品番号だけで、その図解、名称などが容易に引き出せます。
- 部品をご注文いただくときは、必ず部品番号だけを明示してください。
なお、このパーツカタログの記載事項は改良により、予告なく変更されることがありますので、あらかじめご了承ください。

目次

	頁
アームベッド機構(1).....	2-3
アームベッド機構(2).....	4-5
カバー機構(1).....	6-7
カバー機構(2).....	8-9
クランクシャフト機構(1).....	10-11
クランクシャフト機構(2).....	12-13
針振り機構(1).....	14-15
針振り機構(2).....	16-17
上ルーパー機構(1).....	18-19
上ルーパー機構(2).....	20-21
下ルーパー機構.....	22-23
二重環ルーパー機構(1).....	24-25
二重環ルーパー機構(2).....	26-27
送り機構(1).....	28-29
送り機構(2).....	30-31
上送り機構(1).....	32-33
上送り機構(2).....	34-35
上下メス機構.....	36-37
押エ機構.....	38-39
給油機構.....	40-41
給油機構(旧タイプ).....	42-43
H.R.装置.....	44-45
ヒダ取り装置.....	46-47
KL100途中いせ込み装置.....	48-49
当定規・パイピングアダッチメント.....	50-51
据付付属品.....	52-53
付属品.....	54-55
糸立台.....	56-57
ゲージパーツ系列構成図.....	58-93
ゲージパーツ表.....	94-102
インデックス.....	104-107

INTRODUCTION

- This parts catalog covers the ETS32 machine manufactured from May, 1989.
- On pages 2~57, each mechanism is arranged on facing pages, the first page containing the illustrations and the second page containing the data of the individual parts.
The number given to each illustration is the REF. NO. on the parts list.
- Gauge parts construction charts/gauge parts lists.
Gauge parts are used in some machine types and sewing gauges only. Pages 58~93 contain the gauge parts construction charts in order to know the illustrations and the combinations of the parts, and pages 94~102 contain the gauge parts lists to obtain the data at a glance.
- A part number index is attached to the back of this catalog for convenience.
- When placing orders for parts from this catalog, use ONLY THE PART NUMBER.
- This parts catalog is applicable to your machine and is subject to change without notification.

TABLE OF CONTENTS

	Page
Machine bed frame (1).....	2-3
Machine bed frame (2).....	4-5
Covers (1).....	6-7
Covers (2).....	8-9
Crankshaft drive mechanism (1).....	10-11
Crankshaft drive mechanism (2).....	12-13
Needle drive mechanism (1).....	14-15
Needle drive mechanism (2).....	16-17
Upper looper drive mechanism (1).....	18-19
Upper looper drive mechanism (2).....	20-21
Lower looper drive mechanism.....	22-23
Chainstitch looper drive mechanism (1).....	24-25
Chainstitch looper drive mechanism (2).....	26-27
Feed mechanism (1).....	28-29
Feed mechanism (2).....	30-31
Top feed mechanism (1).....	32-33
Top feed mechanism (2).....	34-35
Knife drive mechanism.....	36-37
Presser foot mechanism.....	38-39
Lubricating mechanism.....	40-41
Lubricating mechanism (Old type).....	42-43
H.R. device.....	44-45
Shirring attachment.....	46-47
KL100 intermittent attachment.....	48-49
Edge guide piping attachment.....	50-51
Parts for semi-submerged installation.....	52-53
Accessories.....	54-55
Thread stand.....	56-57
Gauge parts construction chart.....	58-93
Gauge parts list.....	94-102
Part number index.....	104-107

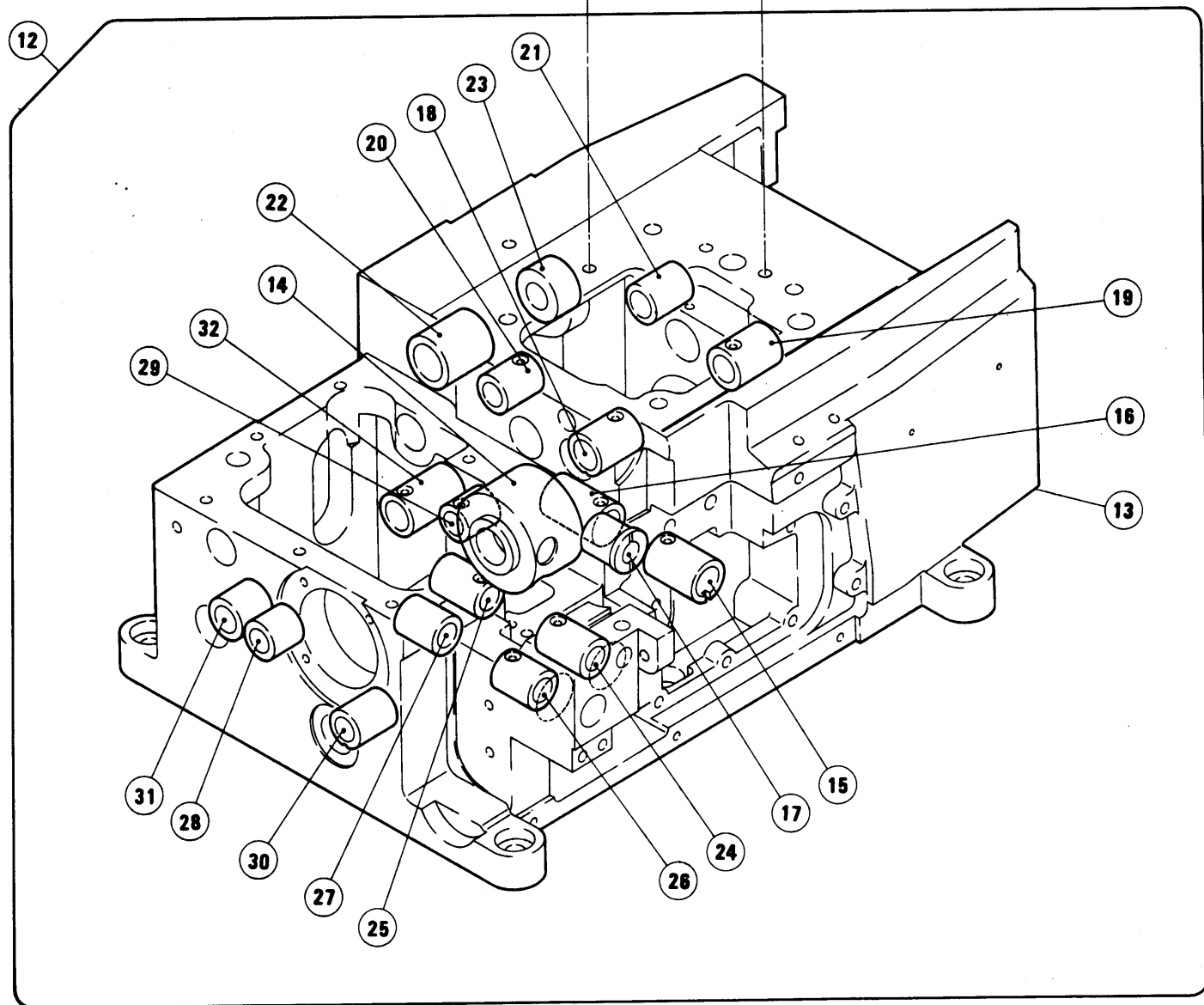
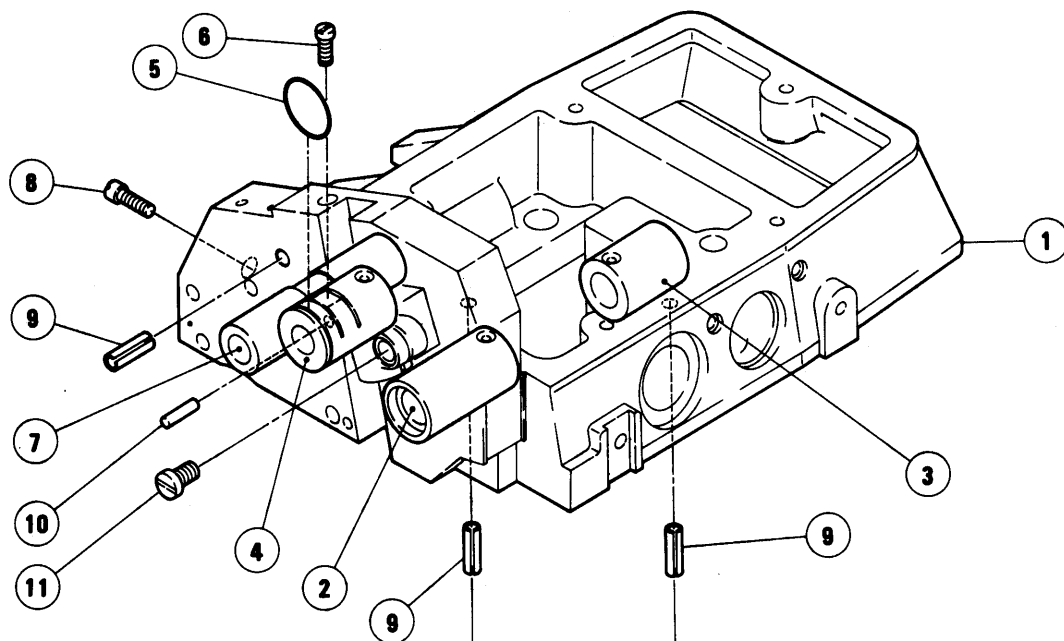

アームベッド機構(1)

MACHINE BED FRAME(1)

REF. NO.	PART NO. 部品番号	名称	NAME	QT.
1	212001-FD	アーム (右)	MACHINE ARM (RIGHT)	1
2	210234	ブッシュユ	BUSHING	1
3	210233	ブッシュユ	BUSHING	1
4	210242	ブッシュユ	BUSHING	1
5	210057	Oリング	O RING	1
6	2133-1	平ネジ / C 5	SCREW	1
7	212048	ブッシュユ	BUSHING	1
8	2133-1	平ネジ / C 5	SCREW	1
9	201002	スプリングピン	PIN	3
10	211385	平行ピン	PIN	1
11	5357	平ネジ / C 9	SCREW	1
12	212000-FD	ベッド (組)	MACHINE BED COMPLETE	1
13	212329-FD	ベッド	MACHINE BED	1
14	211533	ブッシュユ	BUSHING	1
15	210101	ブッシュユ	BUSHING	1
16	210102	ブッシュユ	BUSHING	1
17	210110	ブッシュユ	BUSHING	1
18	210068	ブッシュユ	BUSHING	1
19	210067	ブッシュユ	BUSHING	1
20	212154	ブッシュユ	BUSHING	1
21	210297	ブッシュユ	BUSHING	1
22	212037	ブッシュユ	BUSHING	1
23	212038	ブッシュユ	BUSHING	1
24	210124	ブッシュユ	BUSHING	1
25	210125	ブッシュユ	BUSHING	1
26	210296	ブッシュユ	BUSHING	1
27	210297	ブッシュユ	BUSHING	1
28	210292	ブッシュユ	BUSHING	1
29	252005	ブッシュユ	BUSHING	1
30	210164	ブッシュユ	BUSHING	1
31	210143	ブッシュユ	BUSHING	1
32	210102	ブッシュユ	BUSHING	1

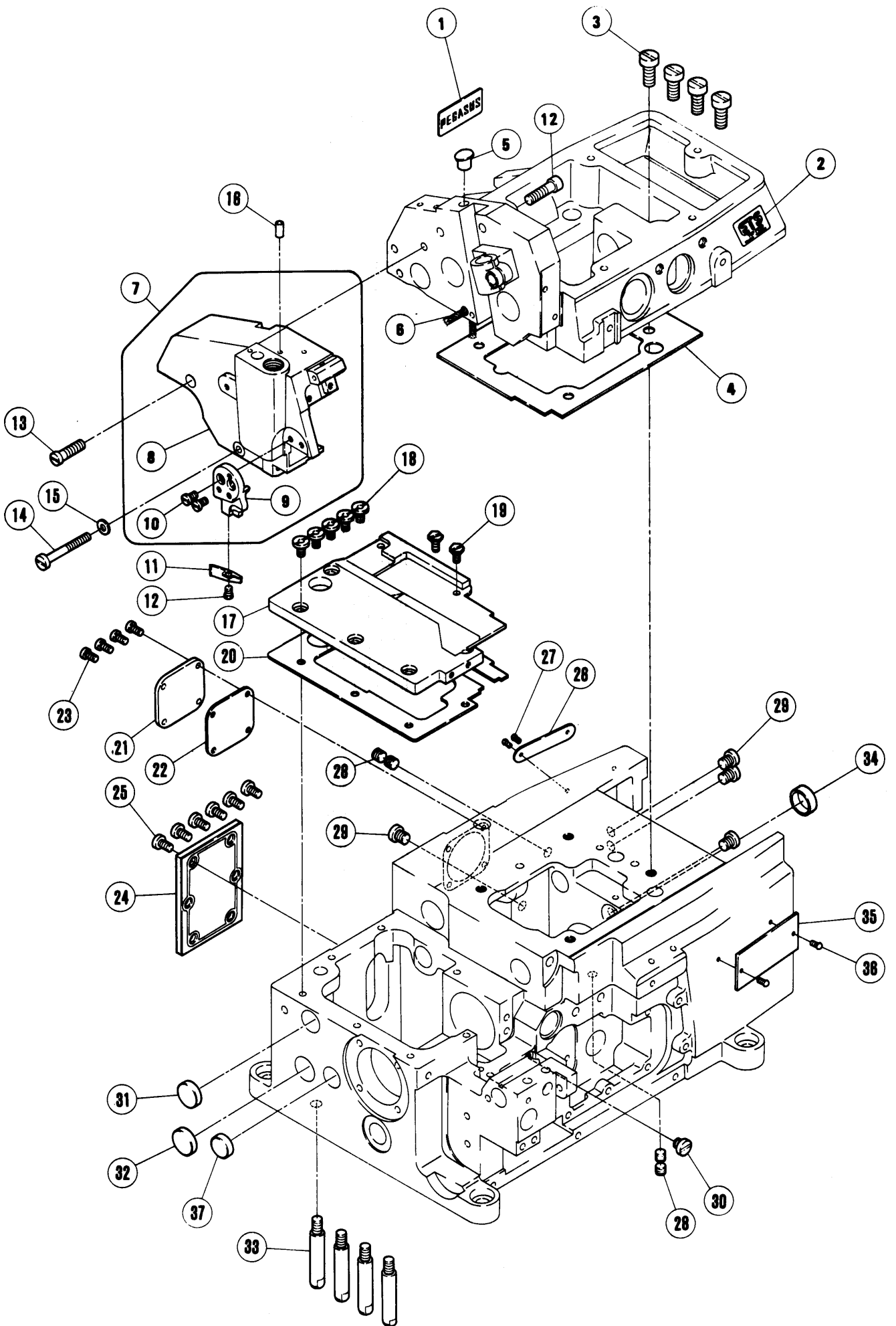

アームベッド機構(2)

MACHINE BED FRAME(2)

REF. NO.	PART NO.	名称	NAME	QT.
1	205722A	銘板	NAME PLATE	1
2	9A3001	ラベル	LABEL	1
3	5078	平ネジ / C 1 1	SCREW	4
4	210002	ガスケット	GASKET	1
5	240052	栓	PLUG	1
6	202175	給油紐	OIL WICK	1
7	212489AFD	アーム (左) (組)	MACHINE ARM (LEFT) ASSEMBLY	1
8	212004AFD	アーム (左)	MACHINE ARM (LEFT)	1
9	211389-HD	アームカバー (左)	ARM COVER (LEFT)	1
10	5328	平ネジ / C 4	SCREW	2
11	212985	カバー	COVER	1
12	5053	平ネジ / C 4	SCREW	1
13	5163	平ネジ / C 8	SCREW	2
14	5595	平ネジ / C 5	SCREW	1
15	200149	ガスケット	GASKET	1
16	210528	給油パイプ	OIL PIPE	1
17	212007	上蓋	BED PLATE	1
18	4009-1	平ネジ / C 5	SCREW	5
19	5482	六角ネジ / C 5	SCREW	2
20	212008	ガスケット	GASEKT	1
21	212010-FD	後蓋	COVER PLATE	1
22	212011	ガスケット	GASKET	1
23	5142	平ネジ / C 4	SCREW	4
24	210005	送り調節蓋	COVER PLATE	1
25	5117	平ネジ / C 5	SCREW	6
26	230047	機番板	SERIAL NUMBER PLATE	1
27	210679	止ピン	PIN	2
28	2913-1	止ネジ / C 1 0	SCREW	4
29	5332A	平ネジ / C 1 0	SCREW	4
30	5434A	平ネジ / C 1 0	SCREW	1
31	208173	栓	PLUG	1
32	210003	栓	PLUG	1
33	204006	足ピン	BED PIN	4
34	210003	栓	PLUG	1
35	212279A	形式板	TYPE PLATE	1
36	210679	止ピン	PIN	2
37	205088	栓	PLUG	1

17 送り形式：2N
Feed Pattern：2N

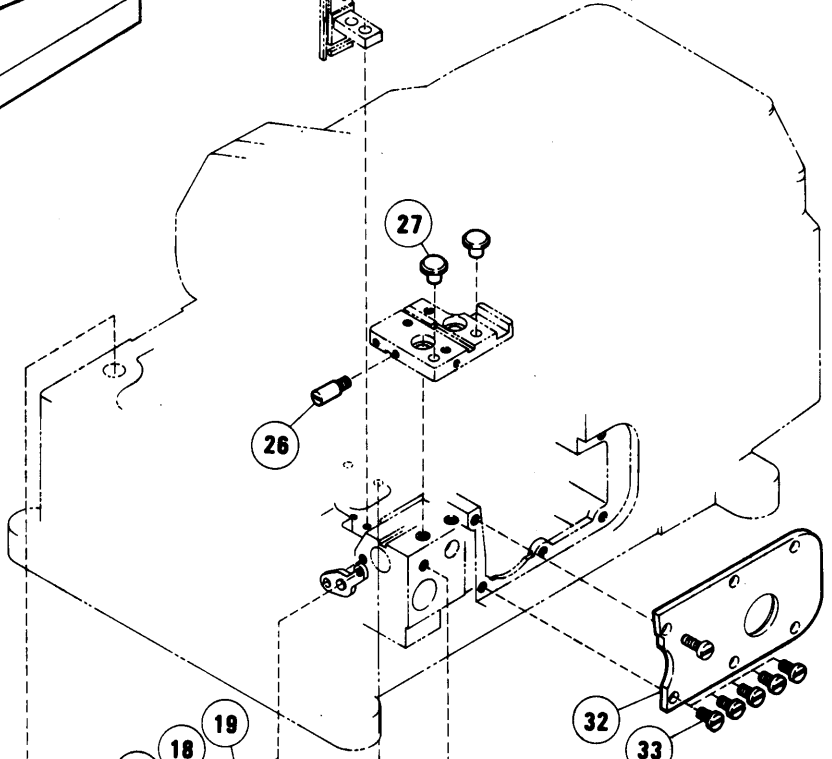
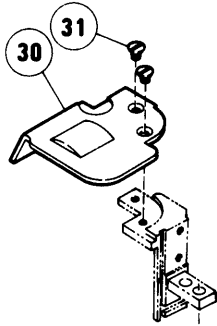
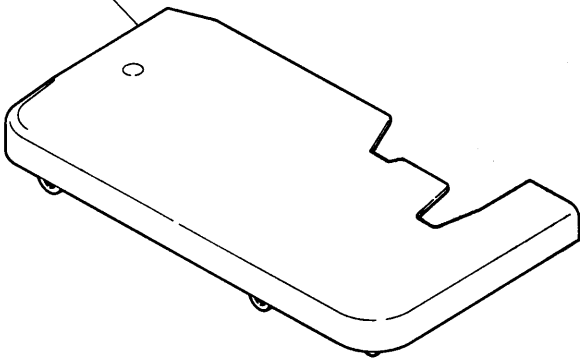

1 送り形式：2N以外
Feed Pattern：Except 2N

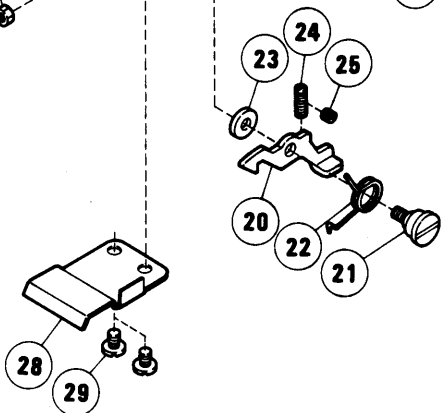
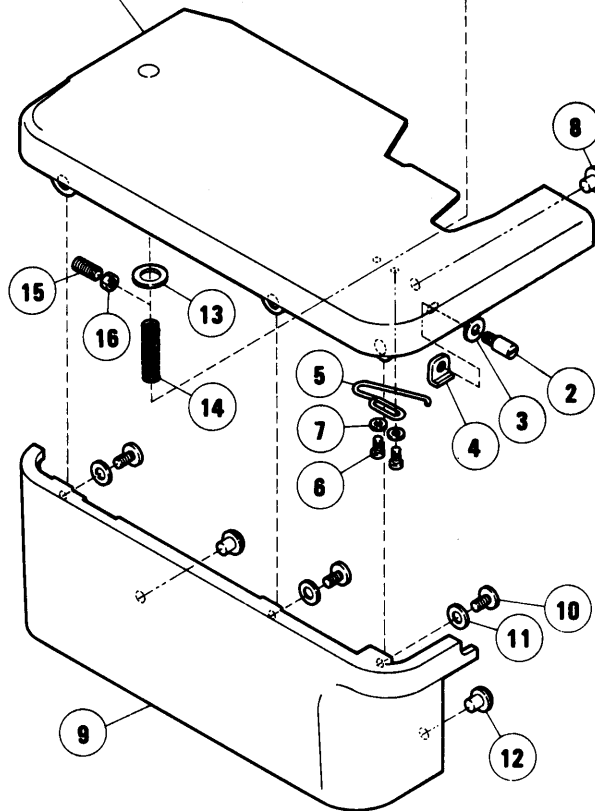

カバ-機構(1)

COVERS(1)

REF. NO.	PART NO. 部品番号	名称	NAME	QT.
1	210883	クロスプレート	CLOTH PLATE (WIDE)	1
2	210022	ピン付ネジ / C 4	SCREW	1
3	137906	座金	WASHER	1
4	211300	四角ナット / C 4	NUT	1
5	210024	線細工バネ	SPRING	1
6	5012	平ネジ / C 3	SCREW	2
7	202875	座金	WASHER	2
8	210025	振動止メ	CUSHION	1
9	210027-FB	横カバ- (広巾)	SIDE COVER (WIDE)	1
10	4009-1	平ネジ / C 5	SCREW	3
11	201185	座金	WASHER	3
12	210025	振動止メ	CUSHION	2
13	210020	座金	WASHER	1
14	192130	圧縮バネ	SPRING	1
15	5483	止ネジ / C 3	SCREW	1
16	3044	六角ナット / C 5	NUT	1
17	210885	クロスプレート	CLOTH PLATE (WIDE) (2N)	1
18	1174	平ネジ / C 4	SCREW	1
19	3091	六角ナット / C 4	NUT	1
20	210021	ラッチ	LATCH	1
21	5488	段付ネジ / C 5	SCREW	1
22	210023	ネジリバネ	SPRING	1
23	208245	座金	WASHER	1
24	1435	止ネジ / C 5	SCREW	1
25	1459	止ネジ / C 4	SCREW	1
26	210022	ピン付ネジ / C 4	SCREW	1
27	210025	振動止メ	CUSHION	2
28	210007	カバ- / 送り台	FEED BAR COVER	1
29	2905	平ネジ / C 5	SCREW	2
30	210006	送りエキセンカバ-	COVER/FEED ECCENTRIC	1
31	5480	皿ネジ / C 3	SCREW	2
32	210117	上ル-バ-台カバ-	UPPER LOOPER HOLDER COVER	1
33	4009-1	平ネジ / C 5	SCREW	5

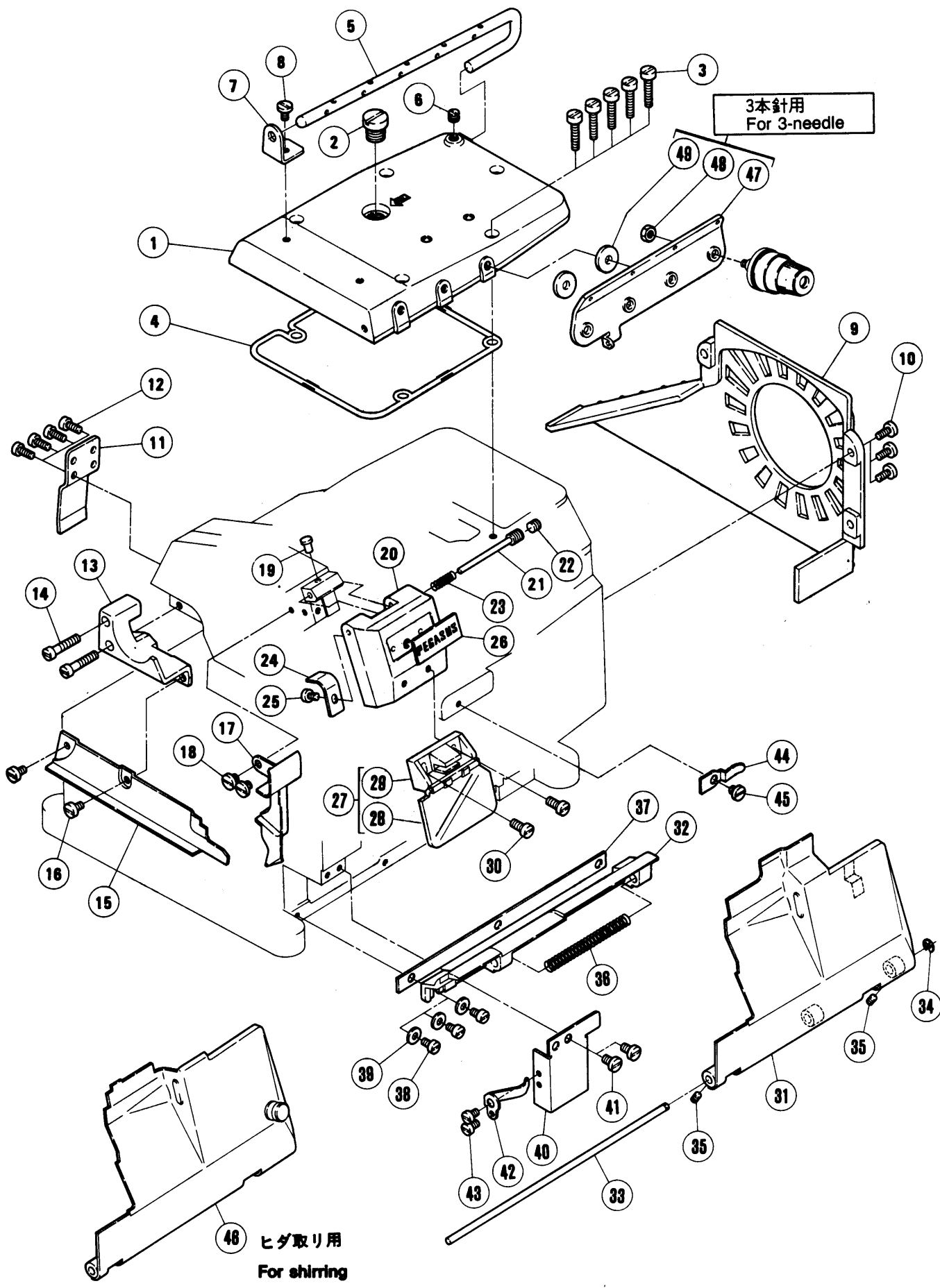

カバー機構(2)

COVERS(2)

REF. NO.	PART NO. 部品番号	名称	NAME	QT.
1	210034-HD	上カバー	TOP COVER	1
2	5198	平ネジ / C 1 4	SCREW	1
3	5095	平ネジ / C 5	SCREW	5
4	210035	Oリング	O RING	1
5	210036	糸道棒	THREAD GUIDE BAR	1
6	5060	止ネジ / C 8	SCREW	1
7	210037	ブラケット	BRACKET	1
8	4009-1	平ネジ / C 5	SCREW	1
9	210028-FB	ベルトカバー	BELT COVER	1
10	5117	平ネジ / C 5	SCREW	3
11	212009	後カバー	REAR COVER	1
12	5142	平ネジ / C 4	SCREW	4
13	212006	ブラケット	BRACKET	1
14	5163	平ネジ / C 8	SCREW	2
15	212005	布案内	FABRIC GUARD	1
16	2905	平ネジ / C 5	SCREW	2
17	212609-91	カバー (A) / アーム左	COVER/MACHINE ARM LEFT	1
18	2905	平ネジ / C 5	SCREW	2
19	198192	当ゴム	CUSHION RUBBER	1
20	211959-FD	針糸カバー	NEEDLE THREAD COVER	1
21	5589	段付ネジ / C 8	SCREW	1
22	5060	止ネジ / C 8	SCREW	1
23	211958	圧縮バネ	SPRING	1
24	210223	板バネ	FLAT SPRING	1
25	1216	平ネジ / C 4	SCREW	1
26	205722A	銘板	NAME PLATE	1
27	208747	安全カバー (組)	EYE GUARD COMPLETE	1
28	205685	アイガード	EYE GUARD	1
29	208744	安全カバー 取付台 (組)	EYE GUARD BRACKET COMPLETE	1
30	1175-3	平ネジ / C 4	SCREW	2
31	210270	前カバー (組)	FRONT COVER ASSEMBLY	1
32	210042	ヒンジ / 前カバー	HINGE/FRONT COVER	1
33	208009	平行ピン	PIN	1
34	200555	止メ輪	RING	1
35	5292	止ネジ / C 3	SCREW	2
36	210043	圧縮バネ	SPRING	1
37	210047	ガスケット	GASKET	1
38	1202	平ネジ / C 4	SCREW	3
39	137906	座金	WASHER	3
40	210046	案内 / 前カバー	GUIDE/FRONT COVER	1
41	4009-1	平ネジ / C 5	SCREW	2
42	210045	板バネ	FLAT SPRING	1
43	1216	平ネジ / C 4	SCREW	2
44	210044	板バネ	FLAT SPRING	1
45	2905	平ネジ / C 5	SCREW	1
46	211700	前カバー	FRONT COVER	1
47	211580	糸調子台	TENSION NUT SET PLATE	1
48	3044	六角ナット / C 5	NUT	1
49	204107	座金	WASHER	2

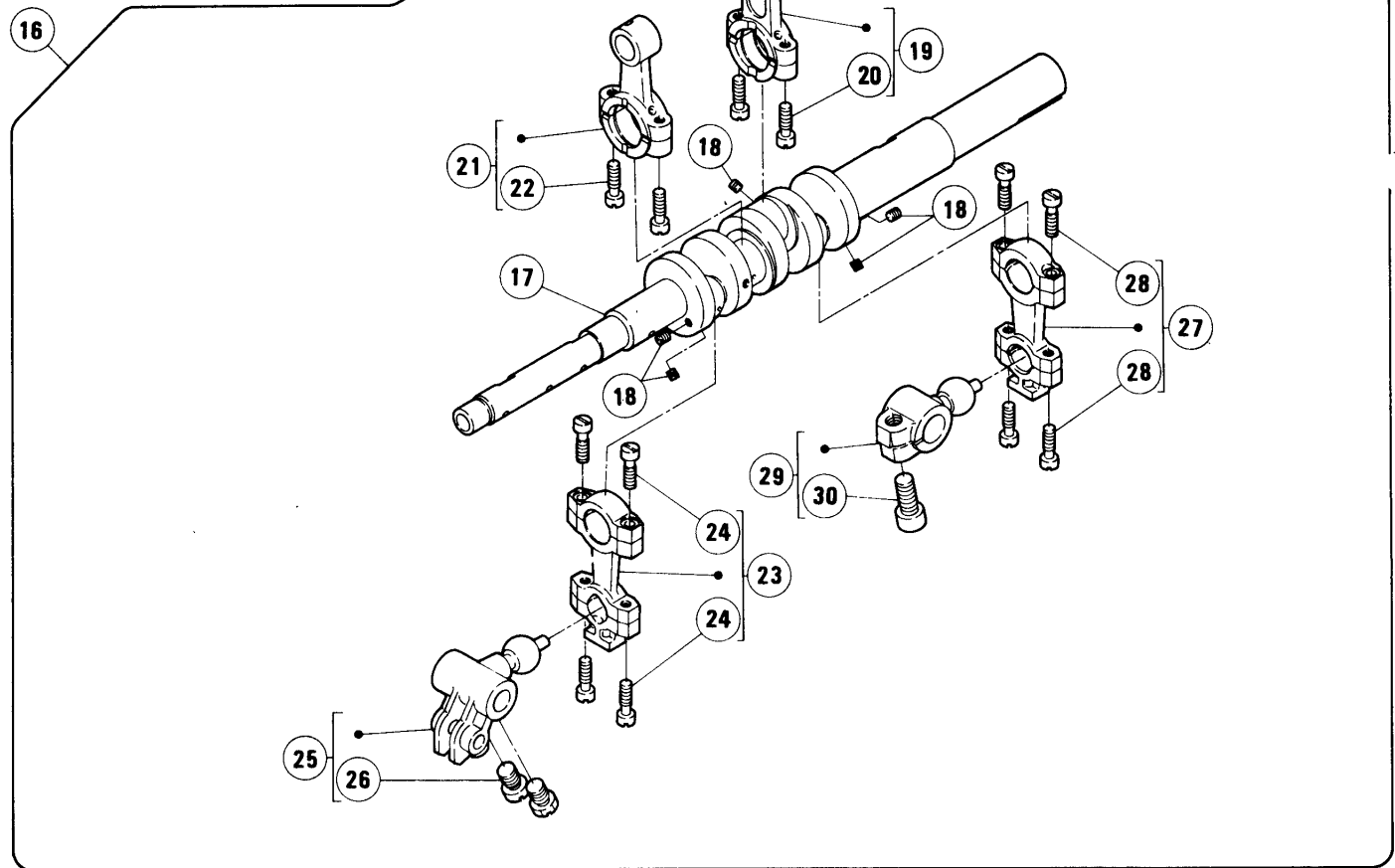
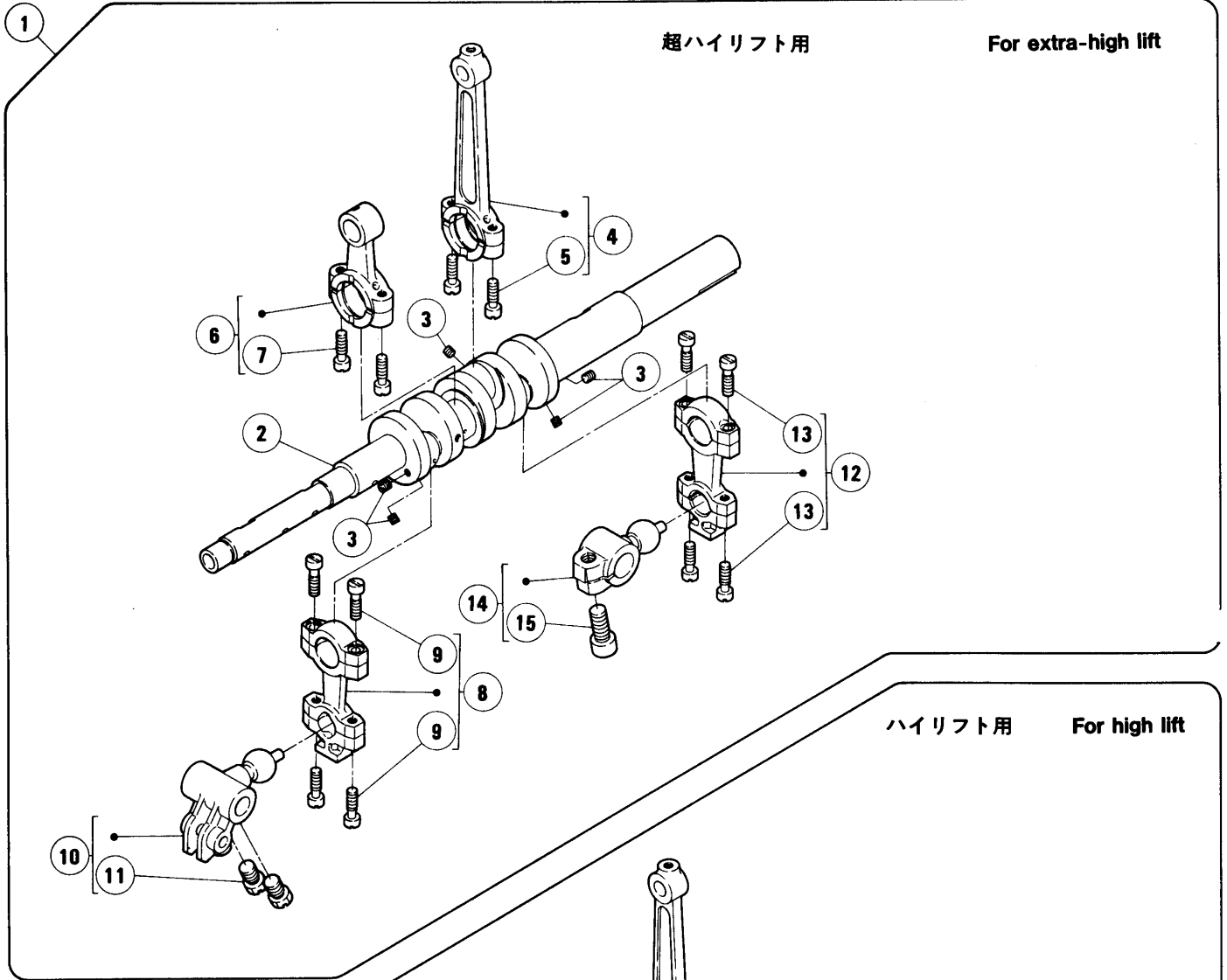

クランクシャフト機構(1)

CRANKSHAFT DRIVE MECHANISM(1)

REF. NO.	PART NO. 部品番号	名称	NAME	QT.
1	212670A	クランクシャフト (組)	CRANKSHAFT ASSEMBLY	1
2	210228-PD	クランクシャフト	CRANKSHAFT	1
3	1459	止ネジ / C 4	SCREW	5
4	210229	ロッド / 針振り	CONNECTION/NEEDLE DRIVE	1
5	5376	平ネジ / C 4	SCREW	2
6	210173	ロッド / 上メス	CONNECTION/UPPER KNIFE DRIVE	1
7	5376	平ネジ / C 4	SCREW	2
8	210091	ロッド	CONNECTION	1
9	5376	平ネジ / C 4	SCREW	4
10	211653	クランク / 下ル - パ -	CRANK/LOWER LOOPER	1
11	2022-4	六角ネジ / C 1 0	SCREW	2
12	210091	ロッド	CONNECTION	1
13	5376	平ネジ / C 4	SCREW	4
14	210731	クランク / 上ル - パ -	CRANK/UPPER LOOPER	1
15	5457	平ネジ / C 9	SCREW	1
16	212657A	クランクシャフト (組)	CRANKSHAFT ASSEMBLY	1
17	210228-PC	クランクシャフト	CRANKSHAFT	1
18	1459	止ネジ / C 4	SCREW	5
19	210229	ロッド / 針振り	CONNECTION/NEEDLE DRIVE	1
20	5376	平ネジ / C 4	SCREW	2
21	210173	ロッド / 上メス	CONNECTION/UPPER KNIFE DRIVE	1
22	5376	平ネジ / C 4	SCREW	2
23	210091	ロッド	CONNECTION	1
24	5376	平ネジ / C 4	SCREW	4
25	210736	クランク / 下ル - パ -	CRANK/LOWER LOOPER DRIVE	1
26	2022-4	六角ネジ / C 1 0	SCREW	2
27	210091	ロッド	CONNECTION	1
28	5376	平ネジ / C 4	SCREW	4
29	210731	クランク / 上ル - パ -	CRANK/UPPER LOOPER	1
30	5457	平ネジ / C 9	SCREW	1

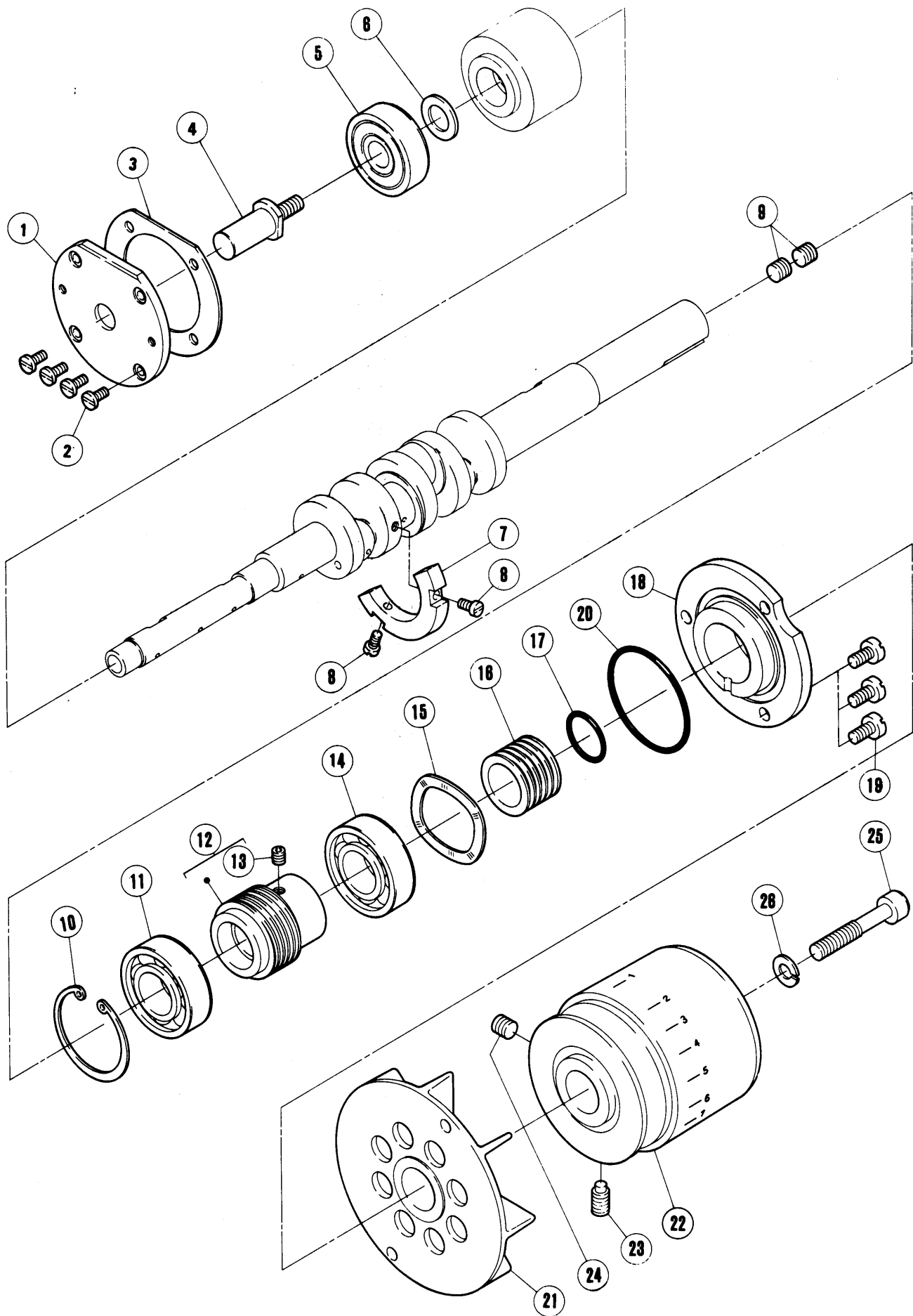

クランクシャフト機構(2)

CRANKSHAFT DRIVE MECHANISM(2)

REF. NO.	PART NO. 部品番号	名称	NAME	QT.
1	204881	ハウジング	HOUSING	1
2	5328	平ネジ / C 4	SCREW	4
3	204319	ガスケット	GASKET	1
4	204873	段付ピン	CRANK SHAFT EXTENSION	1
5	204010	ボールベアリング	BUSHING	1
6	240102	スペーサー	SPACER	1
7	210062	バランスウエイト	BALANCE WEIGHT	1
8	5029	平ネジ / C 5	SCREW	2
9	1448	止ネジ / C 9	SCREW	2
10	211527	止メ輪	RING	1
11	212987	ボールベアリング	BALL BEARING	1
12	211530	ウォーム	WORM	1
13	5461	止ネジ / C 5	SCREW	1
14	211526	ボールベアリング	BALL BEARING	1
15	211529	波板座金	WASHER	1
16	210056	油切り	OIL SEAL	1
17	210057	Oリング	O RING	1
18	211528	ハウジング	BALL BEARING RETAINER	1
19	5117	平ネジ / C 5	SCREW	3
20	210055	Oリング	O RING	1
21	210058	ファン	COOLING FAN	1
22	211345-HD	プーリー	MACHINE PULLEY	1
23	5523	止ネジ / C 9	SCREW	1
24	5050	止ネジ / C 9	SCREW	1
25	5522	平ネジ / C 9	SCREW	1
26	204293	バネ座金	SPRING WASHER	1

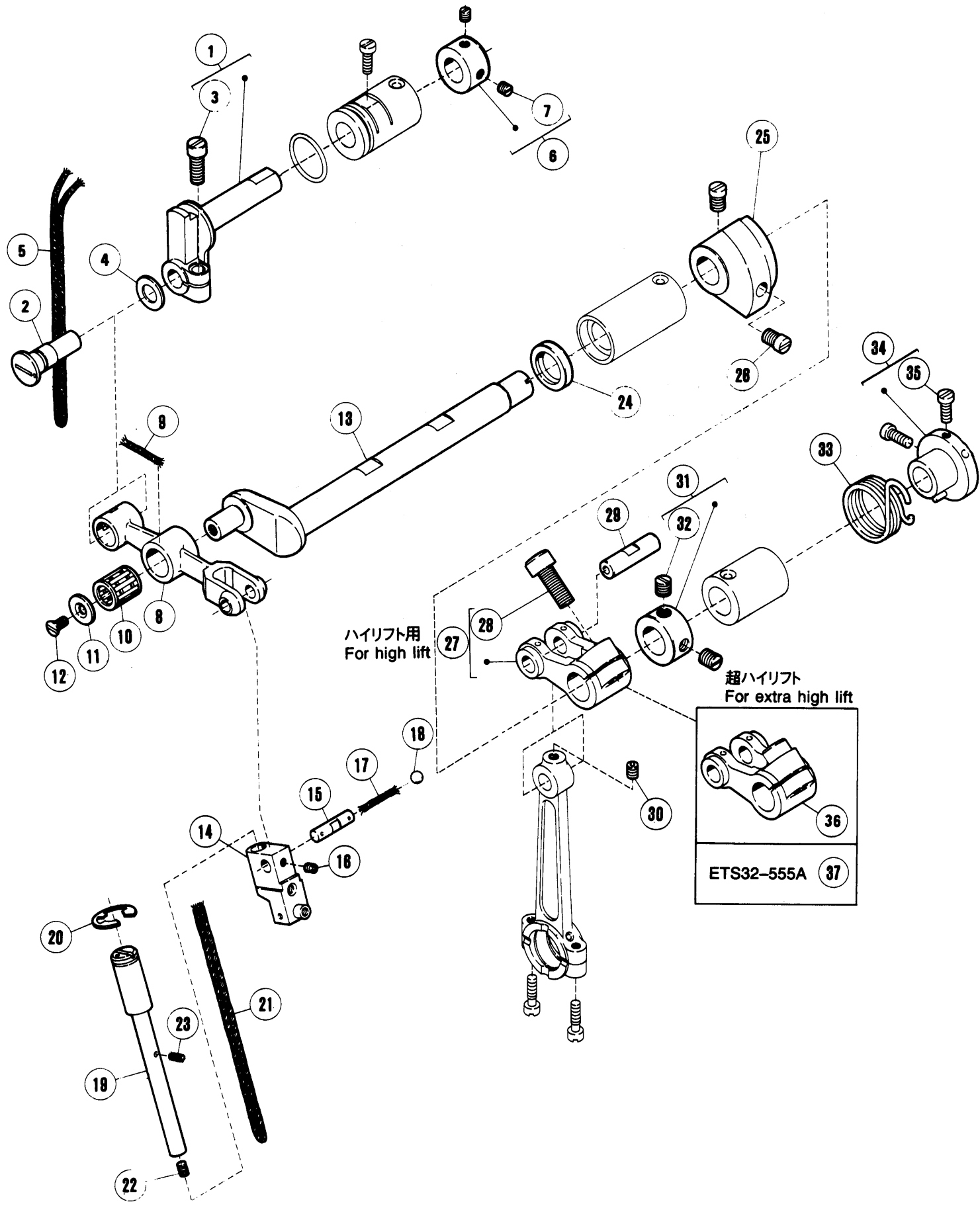

針振り機構(1)

NEEDLE DRIVE MECHANISM(1)

REF. NO.	PART NO. 部品番号	名称	NAME	QT.
1	210239	針振り案内	HOLDER	1
2	210240	エキセンピン	PIN	1
3	5485	平ネジ / C 7	SCREW	1
4	210241	座金	WASHER	1
5	212186	給油紐	OIL WICK	1
6	201056	カラー	COLLAR	1
7	1457	止ネジ / C 5	SCREW	1
8	210235	レバー / 針振り	LEVER/NEEDLE DRIVE	1
9	202175	給油紐	OIL WICK	1
10	210238	ニードルベアリング	NEEDLE BEARING	1
11	210236	座金	WASHER	1
12	5022	皿ネジ / C 3	SCREW	1
13	210232A	軸 / 針振り	SHAFT/NEEDLE DRIVE	1
14	212412A	軸 / 針留案内	SHAFT	1
15	210237A	平行ピン	PIN	1
16	5292	止ネジ / C 3	SCREW	1
17	202174	給油紐	OIL WICK	1
18	240148	栓	PLUG	1
19	212413	軸 / 針留案内	SHAFT	1
20	202577	止メ輪	RING	1
21	202175	給油紐	OIL WICK	1
22	5292	止ネジ / C 3	SCREW	1
23	202174	給油紐	OIL WICK	1
24	210069	オイルシール	OIL SEAL	1
25	210511	バランスウエイト	BALANCE WEIGHT	1
26	5059	平ネジ / C 8	SCREW	1
27	210230	クランク / 針	CRANK/NEEDLE DRIVE	1
28	5457	平ネジ / C 9	SCREW	1
29	204146	平行ピン	PIN	1
30	5461	止ネジ / C 5	SCREW	1
31	201635	カラー	COLLAR	1
32	5060	止ネジ / C 8	SCREW	2
33	212785	ネジリバネ	SPRING	1
34	212786-91	カラー	COLLAR	1
35	1174	平ネジ / C 4	SCREW	1
36	210231	クランク / 針	CRANK/NEEDLE DRIVE	1
37	210231	クランク / 針	CRANK/NEEDLE DRIVE	1

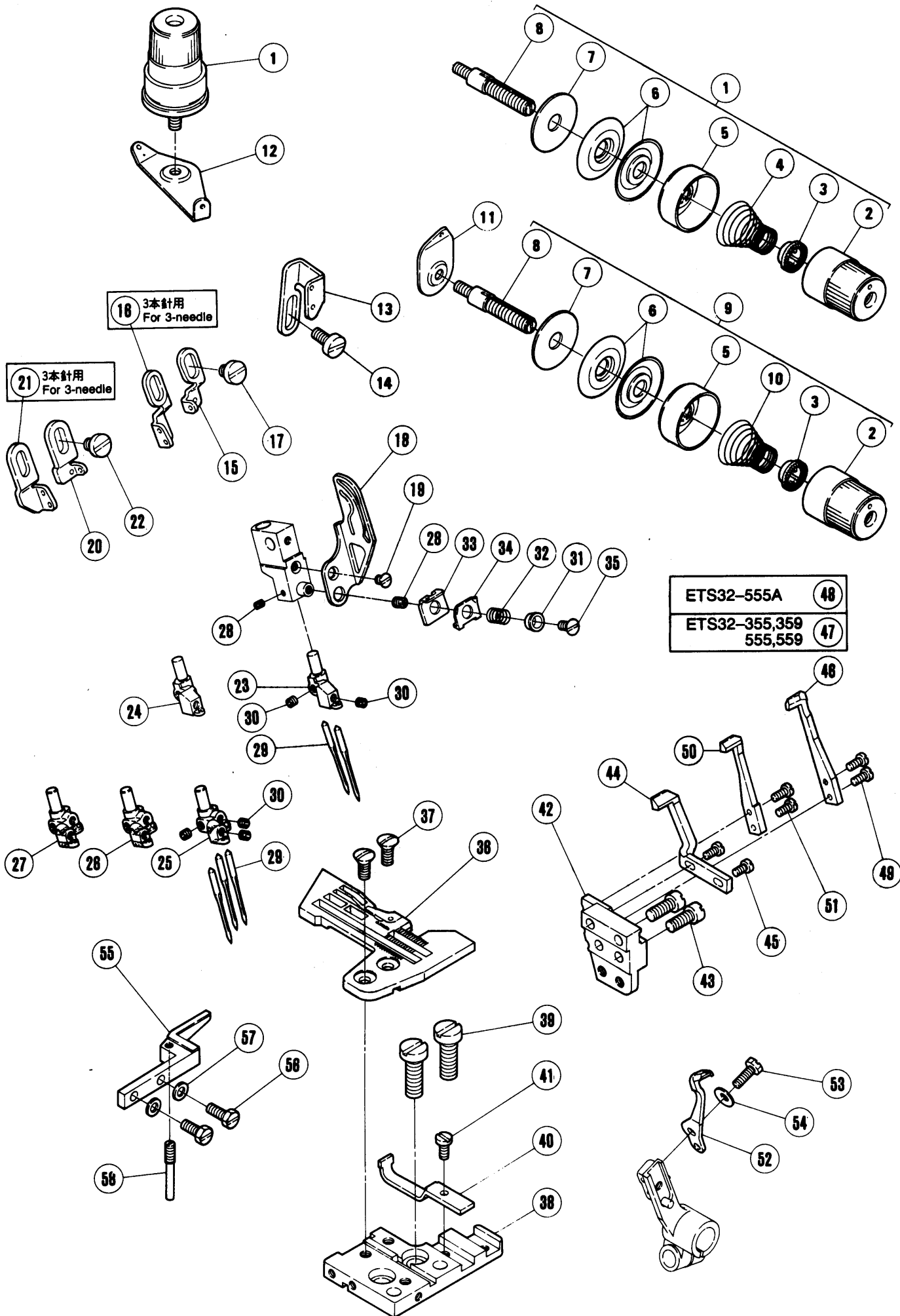

18 3本針用
For 3-needle

21 3本針用
For 3-needle

ETS32-555A	48
ETS32-355,359 555,559	47

針振り機構(2)

NEEDLE DRIVE MECHANISM(2)

REF. NO.	PART NO. 部品番号	名称	NAME	QT.
1	210529	糸調子(組)	THREAD TENSION COMPLETE	2
2	208447	調子ナット	POST NUT	2
3	208448	ラチェット	SPRING BUSHING	2
4	201037	圧縮バネ(強)	SPRING (HEAVY)	2
5	208450	受皿	CUP	2
6	210319	調子皿	TENSION DISC	4
7	208449	フェルト	FELT	2
8	5082A	調子棒/C 5	SCREW STUD	2
9	210530	糸調子(組)	THREAD TENSION COMPLETE	1
10	201086	圧縮バネ(中)	SPRING (MEDIUM)	1
11	202849	調子台	TENSION GUIDE	1
12	210090	調子台	TENSION GUIDE	1
13	210264	糸道/針糸(右)	THREAD GUIDE	1
14	5117	平ネジ/C 5	SCREW	1
15	212725	糸道/針糸(右)	THREAD GUIDE	1
16	212723A	糸道/針糸(右)	NEEDLE/THREAD GUIDE(RIGHT)	1
17	5535	平ネジ/C 5	SCREW	1
18	212721	糸繰り/針糸	THREAD TAKEUP	1
19	5446	皿ネジ/C 3	SCREW	1
20	212724	糸道/針糸(左)	THREAD GUIDE	1
21	212722A	糸道/針糸(左)	NEEDLE/THREAD GUIDE(LEFT)	1
22	5535	平ネジ/C 5	SCREW	1
23	210273	針留/3 M M	NEEDLE HOLDER	1
24	210274	針留/5 M M	NEEDLE HOLDER	1
25	211573	針留/3 M M × 2 M M	NEEDLE HOLDER	1
26	211577	針留/5 M M × 2 M M	NEEDLE HOLDER	1
27	212995	針留/5 M M × 3 M M	NEEDLE HOLDER	1
28	5292	止ネジ/C 3	SCREW	2
29	XXXXXX	針	NEEDLE	2
30	5292	止ネジ/C 3	SCREW	2
31	210750	案内	GUIDE	1
32	210751	圧縮バネ	SPRING	1
33	212681	小調子台	RETAINER BRACKET	1
34	212504	小調子皿	TENSION DISC	1
35	5022	皿ネジ/C 3	SCREW	1
36	XXXXXX	針板	NEEDLE PLATE	1
37	5484-HC	皿ネジ/C 5	SCREW	2
38	211392	針板ブラケット(組)	BRACKET COMPLETE	1
39	5357	平ネジ/C 9	SCREW	2
40	210278	針受(前)/二重環	CHAINSTITCH NEEDLE GUARD FRONT	1
41	5328	平ネジ/C 4	SCREW	1
42	210277	ブラケット/針受	BRACKET/NEEDLE GUARD	1
43	5002	平ネジ/C 5	SCREW	2
44	210279	針受(後)/二重環	CHAINSTITCH NEEDLE GUARD REAR	1
45	5492	平ネジ/C 1	SCREW	2
46	210275A	針受(前)	NEEDLE GUARD (FRONT)	1
47	211578	針受(前)	NEEDLE GUARD(FRONT)	1
48	210275B	針受(前)	NEEDLE GUARD(FRONT)	1
49	5492	平ネジ/C 1	SCREW	2
50	210276	針受(後)	NEEDLE GUARD (REAR)	1
51	5492	平ネジ/C 1	SCREW	2
52	210724	針受(後)	NEEDLE GUARD (REAR)	1
53	5501	六角ネジ/C 4	SCREW	1
54	210930	バネ座金	SPRING WASHER	1
55	210922	針板受(組)	SUPPORT COMPLETE/NEEDLE PLATE	1
56	5501	六角ネジ/C 4	SCREW	2
57	210898	座金	WASHER	2
58	210923	ピン付ネジ/C 4	SCREW	1

××××××は、58~102頁参照。

See pages 58~102 for ××××××.

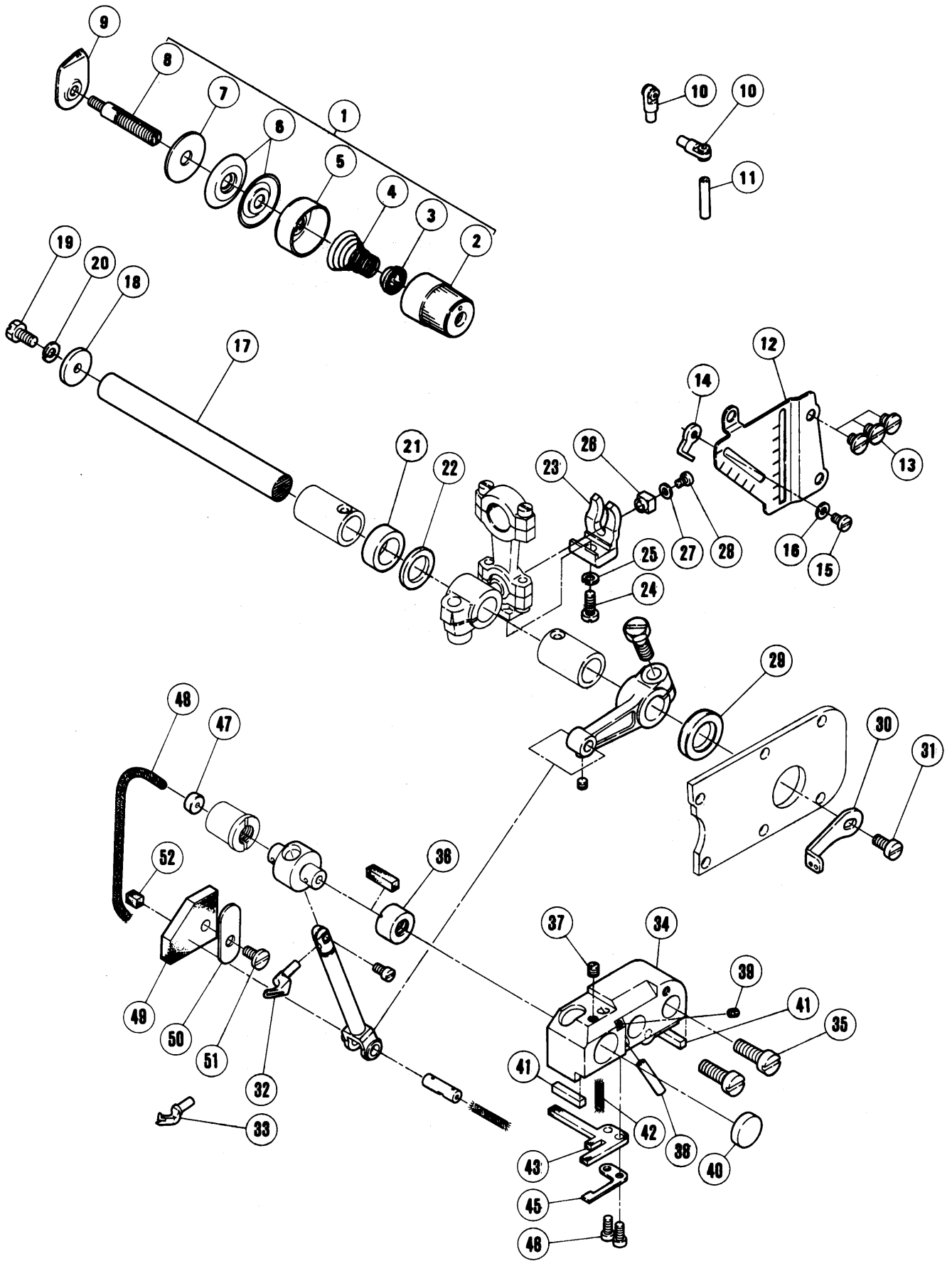

上ルーバー機構(1)

UPPER LOOPER DRIVE MECHANISM(1)

REF. NO.	PART NO. 部品番号	名 称	NAME	QT.
1	210531	糸調子 (組)	THREAD TENSION COMPLETE	1
2	208447	調子ナット	POST NUT	1
3	208448	ラチェット	SPRING BUSHING	1
4	201068	圧縮バネ (弱)	SPRING (LIGHT)	1
5	208450	受皿	CUP	1
6	210319	調子皿	TENSION DISC	2
7	208449	フェルト	FELT	1
8	5082A	調子棒 / C 5	SCREW STUD	1
9	202849	調子台	TENSION GUIDE	1
10	201439A	糸道	THREAD GUIDE	2
11	204657	パイプ	PIPE	1
12	210349	糸道取付板	LOOPER THREAD GUIDE PLATE	1
13	2905	平ネジ / C 5	SCREW	3
14	210350	糸道 / 上ルーバー	THREAD GUIDE/UPPER LOOPER	1
15	5519	平ネジ / C 3	SCREW	1
16	202875	座金	WASHER	1
17	210099	軸 / 上ルーバー	SHAFT/UPPER LOOPER DRIVE	1
18	210100	座金	WASHER	1
19	2193	六角ネジ / C 5	SCREW	1
20	202286	バネ座金	SPRING WASHER	1
21	210267	スペーサー	SPACER	1
22	206180	座金	WASHER	1
23	210092	振れ止め	GUIDE/CONNECTION	1
24	5546	平ネジ / C 5	SCREW	1
25	202286	バネ座金	SPRING WASHER	1
26	210093	角駒	BLOCK	1
27	210585	座金	WASHER	1
28	1231	平ネジ / C 1	SCREW	1
29	210103	オイルシール	OIL SEAL	1
30	212728	糸繰り / 上ルーバー	THREAD TAKEUP/UPPER LOOPER	1
31	2902	平ネジ / C 5	SCREW	1
32	XXXXXX	上ルーバー	UPPER LOOPER	1
33	XXXXXX	スプレッダー	SPREADER	1
34	211995	上ルーバー土台 (組)	BASE/UPPER LOOPER HOLDER	1
35	5282	平ネジ / C 9	SCREW	2
36	210109	ブッシュ	BUSHING	1
37	5408	止ネジ / C 3	SCREW	1
38	204657	パイプ	PIPE	1
39	5292	止ネジ / C 3	SCREW	1
40	208173	栓	PLUG	1
41	210118	ガスケット	GASKET	2
42	202175	給油紐	OIL WICK	1
43	210114	給油フェルト	OIL FELT	1
45	210115	止メ板	SET PLATE	1
46	5012	平ネジ / C 3	SCREW	2
47	208592	栓	CAP	1
48	202174	給油紐	OIL WICK	1
49	210112A	給油フェルト	OIL FELT	1
50	210113	止メ板	SET PLATE	1
51	4009-1	平ネジ / C 5	SCREW	1
52	210721	給油フェルト	OIL FELT	1

×××××は、58~102頁参照。

See pages 58~102 for ×××××.

1

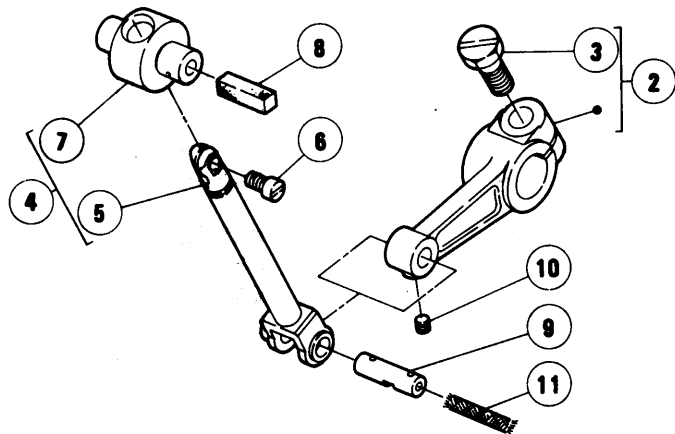

超ハイリフト
Extra-high lift

12

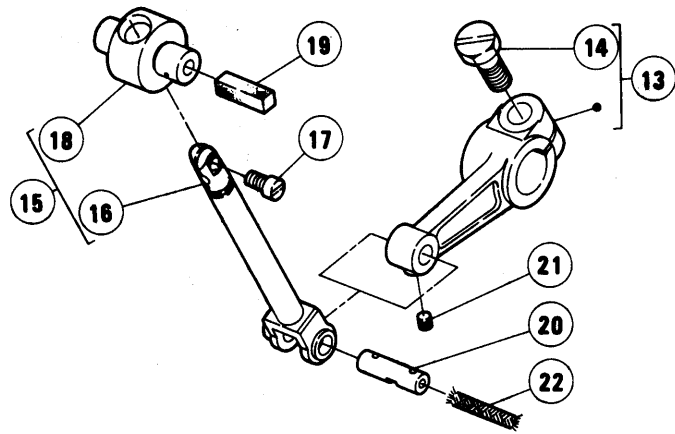

ハイリフト
High lift

REF. NO.	PART NO. 部品番号	名称	NAME	QT.
1	210929A91	上ルーパー台(組)	UPPER LOOPER HOLDER ASSEMBLY	1
2	211655	レバー/上ルーパー	LEVER/UPPER LOOPER HOLDER	1
3	5284	六角ネジ/C 9	SCREW	1
4	211926-T	上ルーパー台(組)	UPPER LOOPER HOLDER ASSEMBLY	1
5	211654-T	上ルーパー台	UPPER LOOPER HOLDER	1
6	1998-2	平ネジ/C 4	SCREW	1
7	210107	上ルーパー台案内	GUIDE/UPPER LOOPER HOLDER	1
8	204274	フェルト(短)	OIL WICK	1
9	210105	平行ピン	PIN	1
10	5292	止ネジ/C 3	SCREW	1
11	202174	給油紐	OIL WICK	1
12	210928A91	上ルーパー台(組)	UPPER LOOPER HOLDER ASSEMBLY	1
13	210104	レバー/上ルーパー	LEVER/UPPER LOOPER HOLDER	1
14	5284	六角ネジ/C 9	SCREW	1
15	211926-T	上ルーパー台(組)	UPPER LOOPER HOLDER ASSEMBLY	1
16	211654-T	上ルーパー台	UPPER LOOPER HOLDER	1
17	1998-2	平ネジ/C 4	SCREW	1
18	210107	上ルーパー台案内	GUIDE/UPPER LOOPER HOLDER	1
19	204274	フェルト(短)	OIL WICK	1
20	210105	平行ピン	PIN	1
21	5292	止ネジ/C 3	SCREW	1
22	202174	給油紐	OIL WICK	1

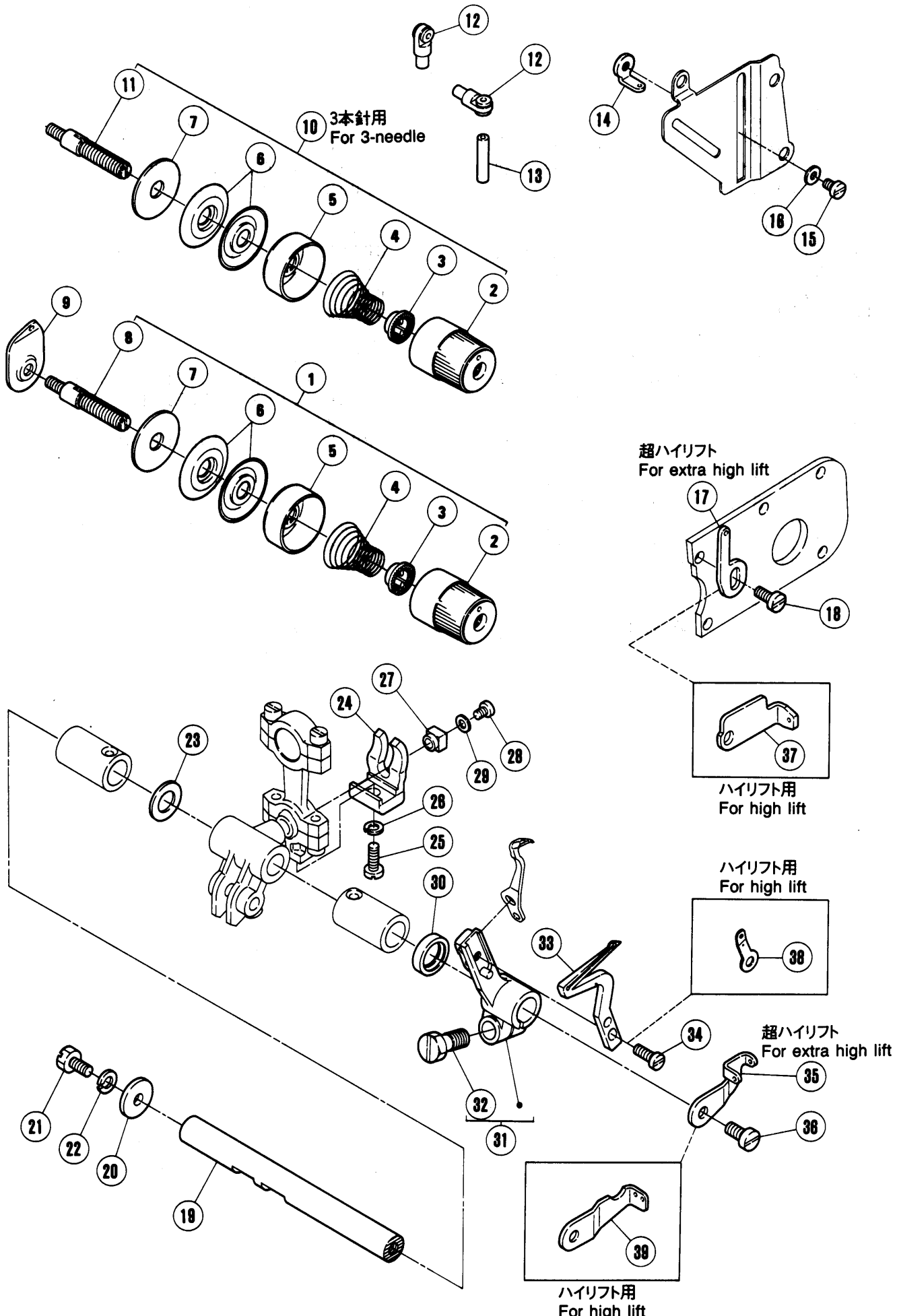

下ルーパー機構

LOWER LOOPER DRIVE MECHANISM

REF. NO.	PART NO. 部品番号	名称	NAME	QT.
1	210530	糸調子 (組)	THREAD TENSION COMPLETE	1
2	208447	調子ナット	POST NUT	1
3	208448	ラチエット (止パイプ)	SPRING BUSHING	1
4	201086	圧縮バネ (中)	SPRING (MEDIUM)	1
5	208450	受皿	CUP	1
6	210319	調子皿	TENSION DISC	2
7	208449	フェルト	FELT	1
8	5082A	調子棒 / C 5	SCREW STUD	1
9	202849	調子台	TENSION GUIDE	1
10	211581	糸調子 (組) (中)	THREAD TENSION COMPLETE	1
11	5143A	調子棒	STUD	1
12	201439A	糸道	THREAD EYELET	2
13	204657	パイプ	PIPE	1
14	201089	糸道	THREAD GUIDE (RIGHT)	1
15	5519	平ネジ / C 3	SCREW	1
16	202875	座金	WASHER	1
17	212727	糸道	THREAD GUIDE	1
18	5441	平ネジ / C 5	SCREW	1
19	210281	軸 / 下ルーパー	SHAFT/LOWER LOOPER	1
20	204107	座金	WASHER	1
21	2193	六角ネジ / C 5	SCREW	1
22	202286	バネ座金	SPRING WASHER	1
23	240102	スベーサー	SPACER	1
24	210092	振レ止メ	GUIDE/CONNECTION	1
25	5546	平ネジ / C 5	SCREW	1
26	202286	バネ座金	SPRING WASHER	1
27	210093	角駒	BLOCK	1
28	1231	平ネジ / C 1	SCREW	1
29	210585	座金	WASHER	1
30	210586	オイルシール	OIL SEAL	1
31	210725	下ルーパー台	LOWER LOOPER LEVER	1
32	5487	六角ネジ / C 9	SCREW	1
33	XXXXXX	下ルーパー	LOWER LOOPER	1
34	1175-2	平ネジ / C 4	SCREW	1
35	212726	糸繰り	THREAD TAKEUP	1
36	2902	平ネジ / C 5	SCREW	1
37	212502	糸道	THREAD GUIDE	1
38	210353	糸道	THREAD GUIDE	1
39	211401	糸繰り	THREAD TAKEUP	1

×××××は、58~102頁参照。

See pages 58~102 for ×××××.

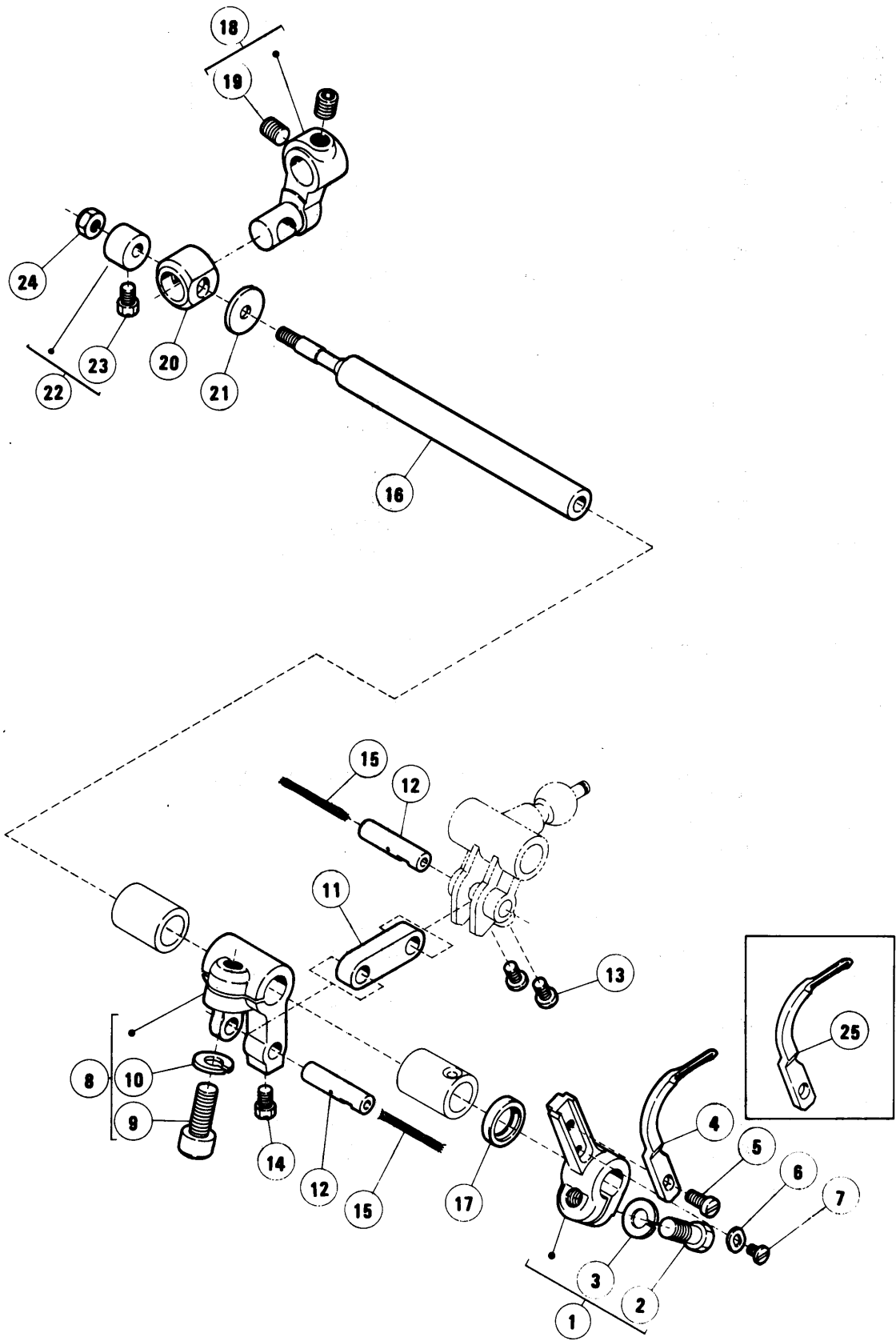

REF. NO.	PART NO. 部品番号	名称	NAME	QT.
1	210298	ルーパー台	LOOPER HOLDER	1
2	5487	六角ネジ / C 9	SCREW	1
3	204293	バネ座金	SPRING WASHER	1
4	210357	二重環ルーパー	DOUBLE CHAINSTITCH LOOPER	1
5	1175-2	平ネジ / C 4	SCREW	1
6	210299	調節金	REGULATOR	1
7	2922	平ネジ / C 1	SCREW	1
8	210294	クランク / ルーパ-振り	CRANK/LOOPER DRIVE	1
9	5457	平ネジ / C 9	SCREW	1
10	204293	バネ座金	SPRING WASHER	1
11	208194	リンク / ルーパ-振り	LINK/LOOPER DRIVE	1
12	208195	平行ピン	PIN	2
13	5328	平ネジ / C 4	SCREW	2
14	5084	六角ネジ / C 5	SCREW	1
15	202176	給油紐	OIL WICK	2
16	208196	軸 / ルーパ-振り	SHAFT/LOOPER DRIVE	1
17	210586	オイルシール	OIL SEAL	1
18	210288	レバー / ルーパ-前後	LEVER/LOOPER AVOIDING	1
19	5461	止ネジ / C 5	SCREW	2
20	210289	角駒 / ルーパ-前後	BLOCK	1
21	208028	座金	WASHER	1
22	208029	カラ-	COLLAR	1
23	5084	六角ネジ / C 5	SCREW	1
24	4802	六角ナット / M 4	NUT	1
25	210357-HC	二重環ルーパー	DOUBLE CHAINSTITCH LOOPER	1

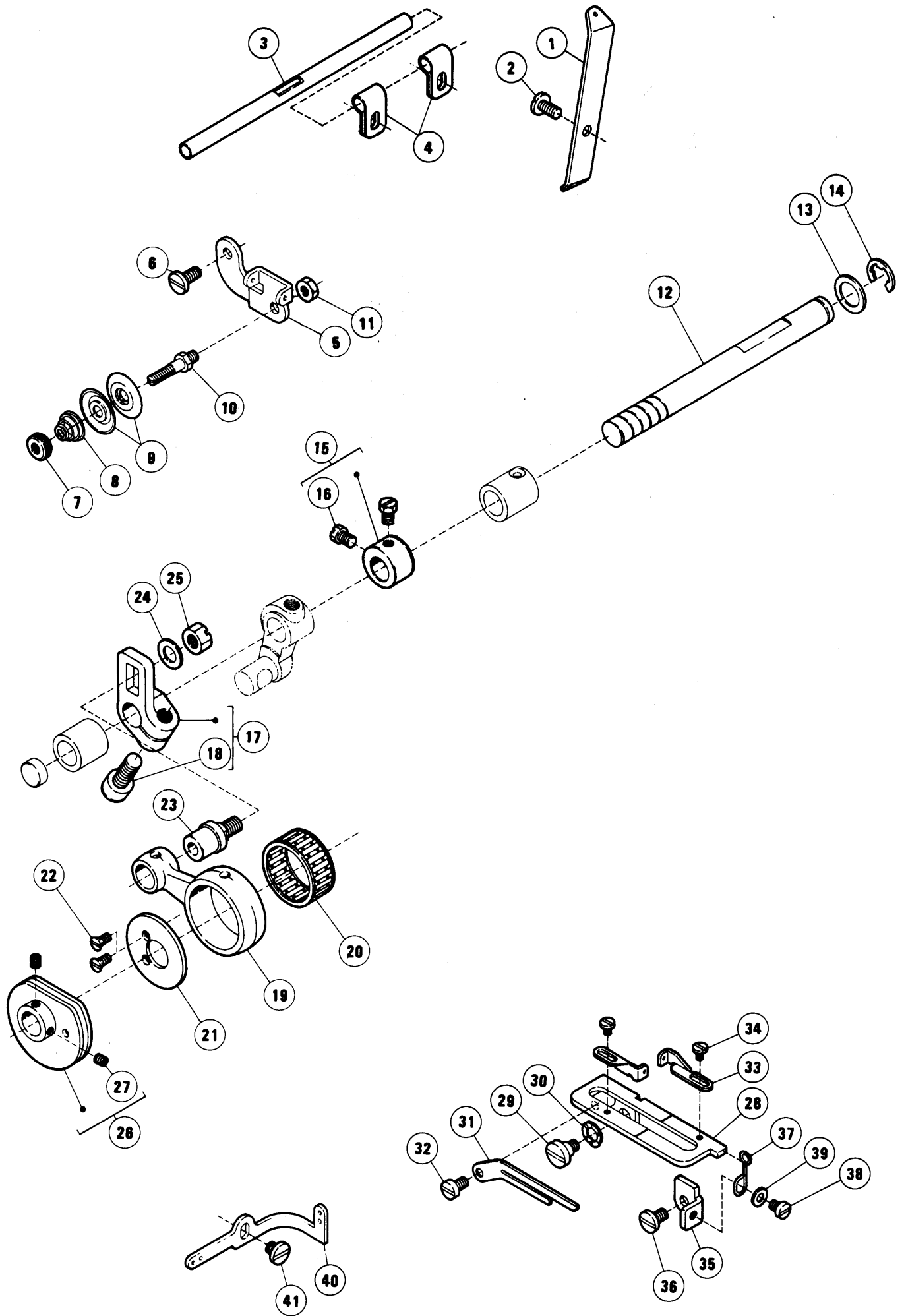

REF. NO.	PART NO. 部品番号	名称	NAME	QT.
1	210309	糸道 / ルーパ - (後)	THREAD GUIDE	1
2	4009-1	平ネジ / C 5	SCREW	1
3	210310	糸道パイプ	THREAD TUBE	1
4	206115	ブラケット	BRACKET	2
5	211386	糸調子台	THREAD GUIDE	1
6	5117	平ネジ / C 5	SCREW	1
7	5526	丸ナット / C 4	NUT	1
8	211388	圧縮バネ	SPRING	1
9	137108	調子皿	TENSION DISC	2
10	211387	糸調子棒	TENSION POST	1
11	3044	六角ナット / C 5	NUT	1
12	212654	軸 / ルーパ - 前後	SHAFT/LOOPER AVOIDING	1
13	240102	スペーサー	SPACER	1
14	205061	止メ輪	RING	1
15	210293	カラ -	COLLAR	1
16	5084	六角ネジ / C 5	SCREW	2
17	210287	クランク / ルーパ - 前後	CRANK/LOOPER AVOIDING	1
18	5457	平ネジ / C 9	SCREW	1
19	210284	ロッド / ルーパ - 前後	CONNECTION/LOOPER AVOIDING	1
20	205015	ニードルベアリング	NEEDLE BEARING	1
21	210283	カラ -	COLLAR	1
22	5259	皿ネジ / C 1	SCREW	2
23	210285	段付ピン	PIN	1
24	202433	座金	WASHER	1
25	5455	六角ナット / C 8	NUT	1
26	210300	糸繰り / ルーパ -	THREAD TAKEUP	1
27	5292	止ネジ / C 3	SCREW	2
28	210304	ルーパ - 糸繰り台	BRACKET/LOOPER THREAD GUIDE	1
29	5494	段付ネジ / C 5	SCREW	1
30	210307	波板座金	WASHER	1
31	210302	糸繰り案内	GUIDE/THREAD TAKEUP	1
32	1216	平ネジ / C 4	SCREW	1
33	210303	糸道 / ルーパ - 糸繰り	THREAD GUIDE	2
34	5077	平ネジ / C 1	SCREW	2
35	210308	ストッパ -	STOPPER	1
36	5453	平ネジ / C 5	SCREW	1
37	210306	線細工バネ	SPRING	1
38	1234	平ネジ / C 4	SCREW	1
39	137906	座金	WASHER	1
40	210311	糸道	THREAD GUIDE	1
41	4009-1	平ネジ / C 5	SCREW	1

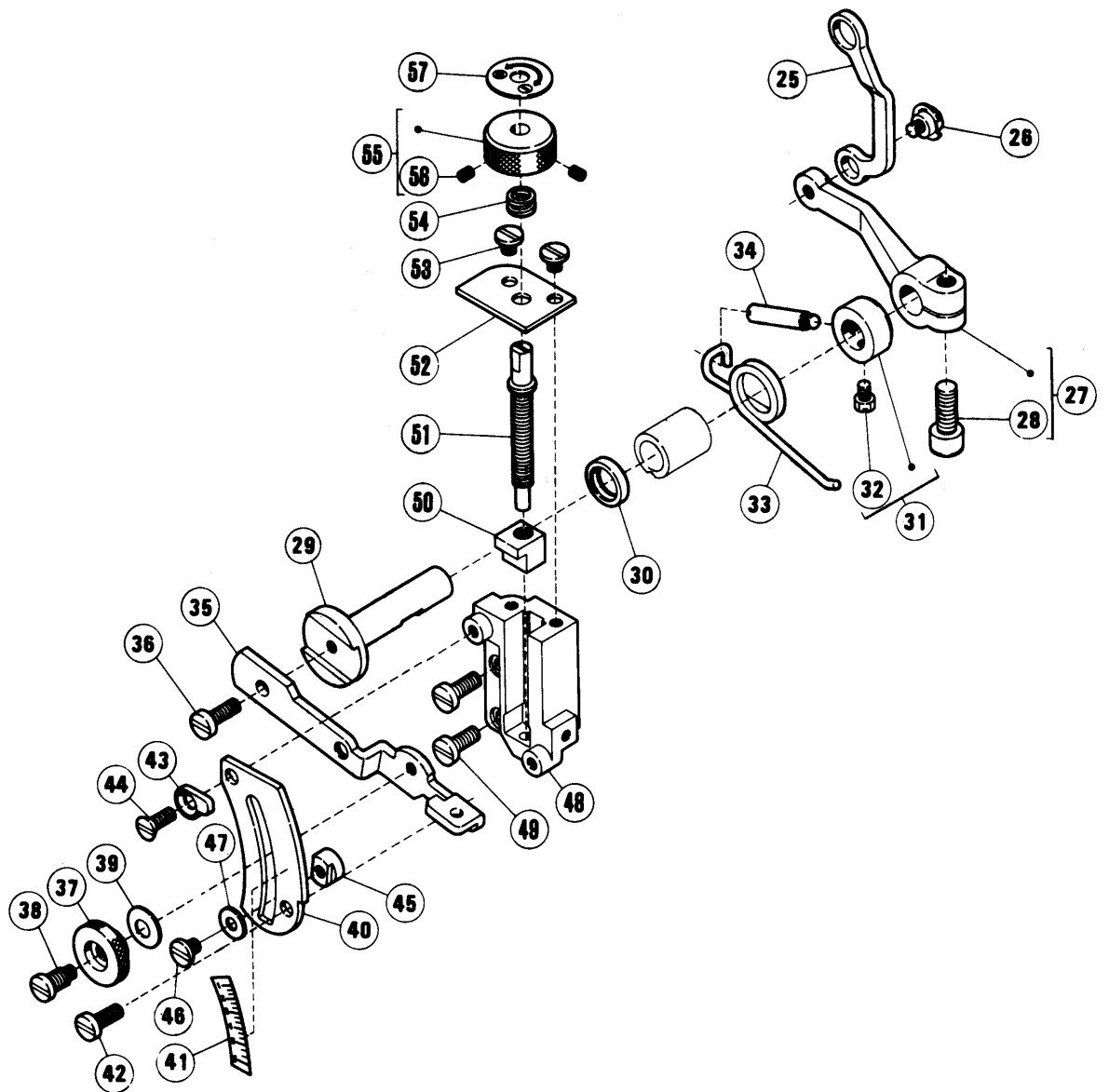
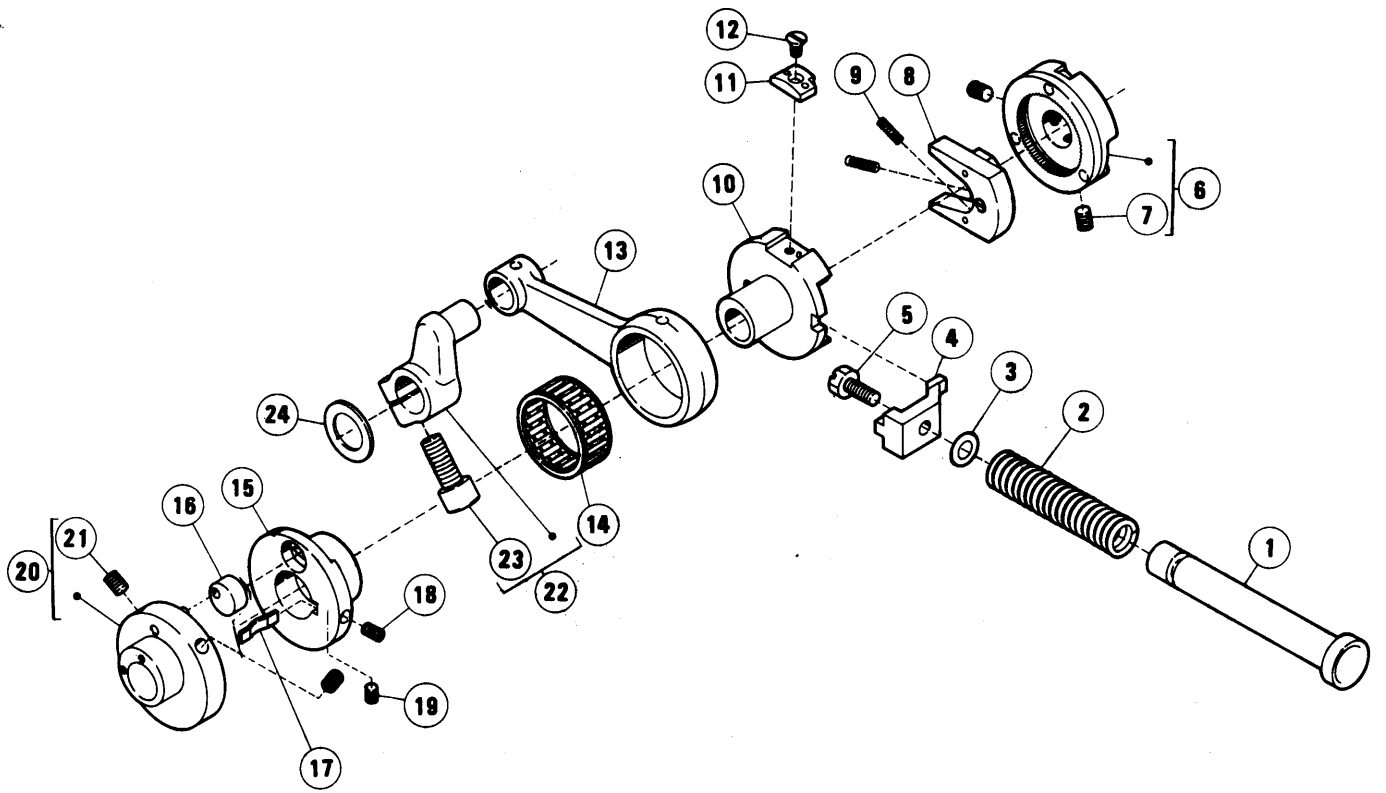

送り機構(1)

FEED MECHANISM(1)

REF. NO.	PART NO. 部品番号	名称	NAME	QT.
1	210137	プッシュボタン	PUSH BUTTON	1
2	210139	圧縮バネ	SPRING	1
3	204185	Oリング	O RING	1
4	210138	ストッパ	STOPPER	1
5	2193	六角ネジ / C 5	SCREW	1
6	210136	ラチェットホイール (組)	RATCHET WHEEL COMPLETE	1
7	5461	止ネジ / C 5	SCREW	2
8	208411	エキセン調節器 (爪) 組	FEED REGULATING RATCHET	1
9	208415	圧縮バネ	SPRING	2
10	211802A	エキセン / 送り調節	ECCENTRIC/FEED REGULATING	1
11	211804	ストッパ	STOPPER	1
12	5437	皿ネジ / C 3	SCREW	1
13	210140	送りロッド	CONNECTION/FEED DRIVE	1
14	204084	ニードルベアリング	NEEDLE BEARING	1
15	210127	送リエキセン	ECCENTRIC/FEED DRIVE	1
16	210129	案内 / 送リエキセン	GUDE/FEED ECCENTRIC	1
17	210130	板バネ	FLAT SPRING	1
18	5427	止ネジ / C 3	SCREW	1
19	5292	止ネジ / C 3	SCREW	1
20	210282A	エキセン / ルーパ前後	ECCENTRIC/LOOPER AVOIDING	1
21	5461	止ネジ / C 5	SCREW	2
22	210141A	クランク / 送り	CRANK/FEED DRIVE	1
23	5457	平ネジ / C 9	SCREW	1
24	208235	座金	WASHER	1
25	210161	リンク / 差動調節	LINK/DIFF. FEED REGULATING	1
26	5316	段付ネジ / C 5	SCREW	1
27	210162	レバー / 差動調節	LEVER/DIFF. FEED REGULATING	1
28	5457	平ネジ / C 9	SCREW	1
29	210163	軸 / 差動調節	SHAFT/DIFF. FEED REGULATING	1
30	204052A	オイルシール	OIL SEAL	1
31	204754A	カラー	COLLAR	1
32	5084	六角ネジ / C 5	SCREW	1
33	204756	ネジリバネ	SPRING	1
34	204757	段付ピン	PIN	1
35	210166	レバー / 差動調節 (左)	LEVER/DIFF. FEED REGULATING	1
36	5117	平ネジ / C 5	SCREW	1
37	210167	ツマミ	THUMB NUT	1
38	5486	段付ネジ / C 5	SCREW	1
39	211301	皿バネ	SPRING	1
40	210168	案内 / 差動調節	REGULATING PLATE/DIFF. FEED	1
41	210170	目盛板	INDICATION PLATE	1
42	5117	平ネジ / C 5	SCREW	1
43	210700	ストッパ	STOPPER	1
44	1732	皿ネジ / C 5	SCREW	1
45	210171	ストッパ	STOPPER	1
46	2905	平ネジ / C 5	SCREW	1
47	201185	座金	WASHER	1
48	211314	差動調節台	REGULATING BASE/DIFF. FEED	1
49	5118	平ネジ / C 5	SCREW	2
50	210535	角駒 / 差動調節	BLOCK/DIFF. FEED REGULATING	1
51	210172	差動調節棒	REGULATING BAR/DIFF. FEED	1
52	210534	案内 / 差動調節棒	GUIDE/DIFF. FEED REG. BAR	1
53	5091	平ネジ / C 5	SCREW	2
54	210533	圧縮バネ	SPRING	1
55	210532	ツマミ	THUMB NUT	1
56	5292	止ネジ / C 3	SCREW	2
57	212179	標示板	MARK	1

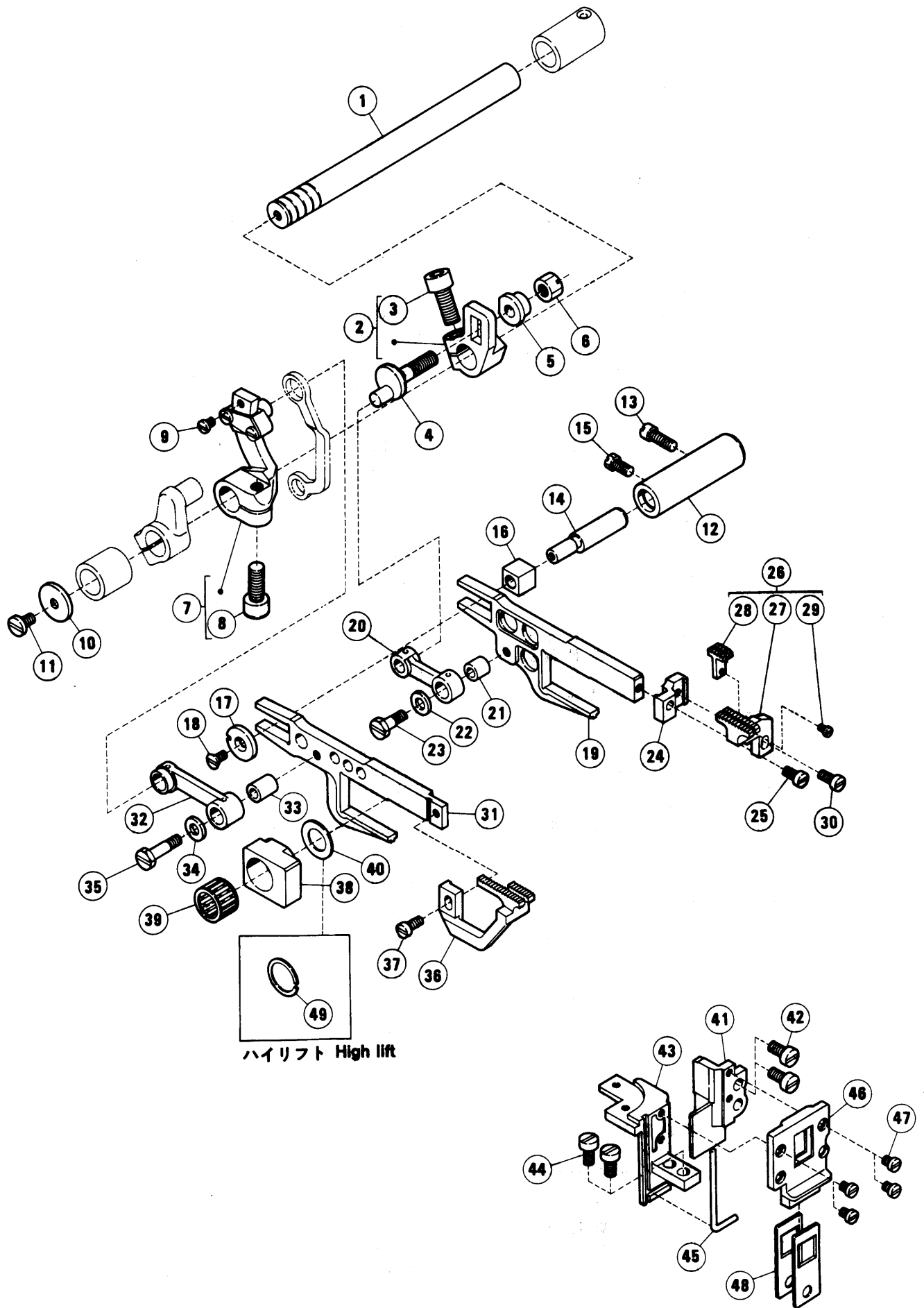

送り機構(2)

FEED MECHANISM(2)

REF. NO.	PART NO. 部品番号	名称	NAME	QT.
1	212028	軸 / 送り	FEED SHAFT	1
2	210144	クランク / 主送り	CRANK/MAIN FEED	1
3	5457	平ネジ / C 9	SCREW	1
4	210145	エキセンピン	PIN	1
5	210146	座金	WASHER	1
6	5455	六角ナット / C 8	NUT	1
7	210152	クランク (組) / 差動送り	CRANK COMPLETE/DIFF. FEED	1
8	5457	平ネジ / C 9	SCREW	1
9	5346	平ネジ / C 3	SCREW	1
10	210100	座金	WASHER	1
11	4009-1	平ネジ / C 5	SCREW	1
12	204129A	送り台案内軸	BUSHING	1
13	2133-1	平ネジ / C 5	SCREW	1
14	204128A	段付ピン	PIN	1
15	5084	六角ネジ / C 5	SCREW	1
16	205418	角駒 / 送り台案内	BLOCK/FEED BAR GUIDE	1
17	204439A	座金	WASHER	1
18	5317	皿ネジ / C 3	SCREW	1
19	210154	主送り台	MAIN FEED BAR	1
20	210147	リンク / 主送り	LINK/MAIN FEED	1
21	210148	ブッシュ	BUSHING	1
22	204115	座金	WASHER	1
23	5489	六角ネジ / C 5	SCREW	1
24	210343	ブラケット / 主送り歯	BRACKET/MAIN FEED DOG	1
25	1175-2	平ネジ / C 4	SCREW	1
26	XXXXXX	主送り歯 (組)	MAIN FEED DOG COMPLETE	1
27	XXXXXX	主送り歯	MAIN FEED DOG	1
28	XXXXXX	補助送り歯	AUXILIARY FEED DOG	1
29	5492	平ネジ / C 1	SCREW	1
30	1175-2	平ネジ / C 4	SCREW	1
31	210155	差動送り台	DIFFERENTIAL FEED BAR	1
32	210153	リンク / 差動送り	LINK/DIFFERENTIAL FEED	1
33	204114	ブッシュ	BUSHING	1
34	204115	座金	WASHER	1
35	5231	六角ネジ / C 5	SCREW	1
36	XXXXXX	差動送り歯	DIFFERENTIAL FEED DOG	1
37	1175-2	平ネジ / C 4	SCREW	1
38	210156	角駒	BLOCK	1
39	206128	ニードルベアリング	NEEDLE BEARING	1
40	208235	座金	WASHER	1
41	210157	案内 (右) / 送り台	GUIDE (RIGHT)/FEED BAR	1
42	5205	平ネジ / C 5	SCREW	2
43	210158	案内 (左) / 送り台	GUIDE (LEFT)/FEED BAR	1
44	2902	平ネジ / C 5	SCREW	2
45	208168	ガスケット	GASKET	1
46	210160	案内 / 油切り	GUIDE/FEED BAR OIL SEAL	1
47	5346	平ネジ / C 3	SCREW	4
48	210159	油切り / 送り台	OIL SEAL	2
49	206129	止メ輪	RING	1

××××××は、58~102頁参照。

See pages 58~102 for ××××××.

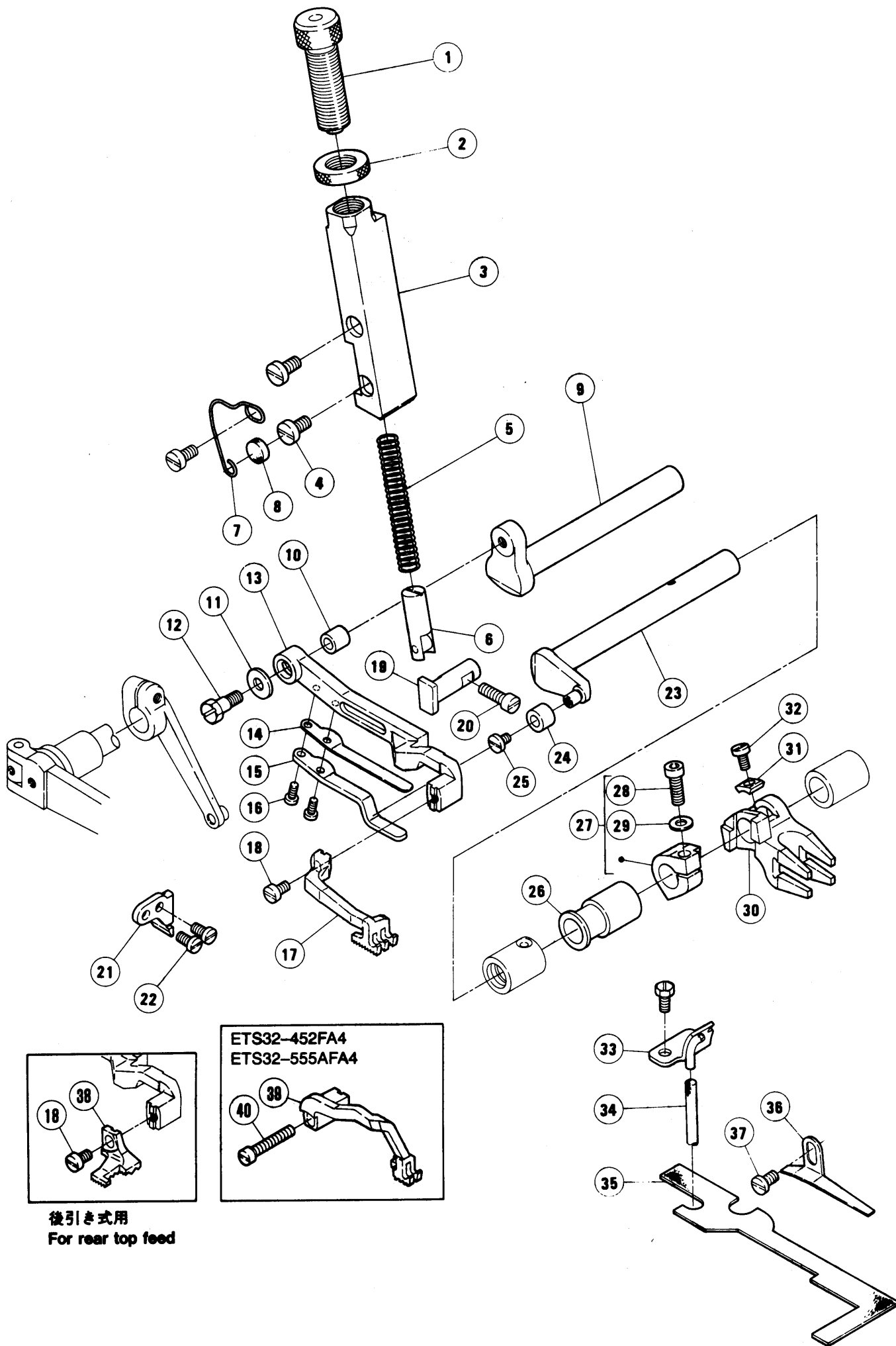

ETS32-452FA4
ETS32-555AFA4

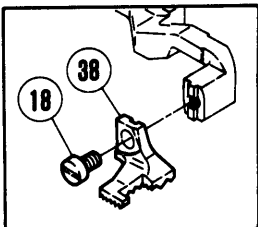

後引き式用
For rear top feed

上送り機構(1)

TOP FEED MECHANISM(1)

REF. NO.	PART NO. 部品番号	名称	NAME	QT.
1	212440	調節ネジ	THUMB SCREW	1
2	210328	調節ナット	ADJUSTING SCREW NUT	1
3	212025	押し棒案内	PRESSER BAR GUIDE	1
4	5117	平ネジ / C 5	SCREW	2
5	212026	圧縮バネ	SPRING	1
6	212021	押し棒 (組)	PRESSER BAR COMPLETE	1
7	212145	線細工バネ	SPRING	1
8	212144	フェルト	FELT	1
9	212036	クラック軸	SHAFT	1
10	210148	ブッシュ	BUSHING	1
11	204115	座金	WASHER	1
12	5489	六角ネジ / C 5	SCREW	1
13	212400	上送り台	TOP FEED BAR	1
14	212448	当板 (上)	PLATE (UPPER)	1
15	212449	当板 (下)	PLATE (LOWER)	1
16	5492	平ネジ / C 1	SCREW	2
17	XXXXXX	上送り歯	TOP FEED DOG	1
18	1175-2	平ネジ / C 4	SCREW	1
19	212019	案内 (右)	GUIDE (RIGHT)	1
20	2133-1	平ネジ / C 5	SCREW	1
21	212020	案内 (左)	GUIDE (LEFT)	1
22	5328	平ネジ / C 4	SCREW	2
23	212404	軸	ROD	1
24	212015	ローラー	ROLLER	1
25	5597	平ネジ / C 1	SCREW	1
26	212405	スペーサー	SPACER	1
27	212447	ラッチ	LATCH	1
28	5568	平ネジ / C 5	SCREW	1
29	307003	座金	WASHER	1
30	212445	クラック	CRANK	1
31	212446	クラック案内	CRANK GUIDE	1
32	5089	平ネジ / C 3	SCREW	1
33	212140	給油パイプ (組)	OIL PIPE ASSEMBLY	1
34	212143	フェルト	FELT	1
35	212146	フェルト	FELT	1
36	212147	フェルト押エ	FELT RETAINER	1
37	2905	平ネジ / C 5	SCREW	1
38	XXXXXX	上送り歯	TOP FEED DOG	1
39	XXXXXX	上送り歯	TOP FEED DOG	1
40	1132	平ネジ / C 4	SCREW	1

××××××は、58~102頁参照。
See pages 58~102 for ××××××.

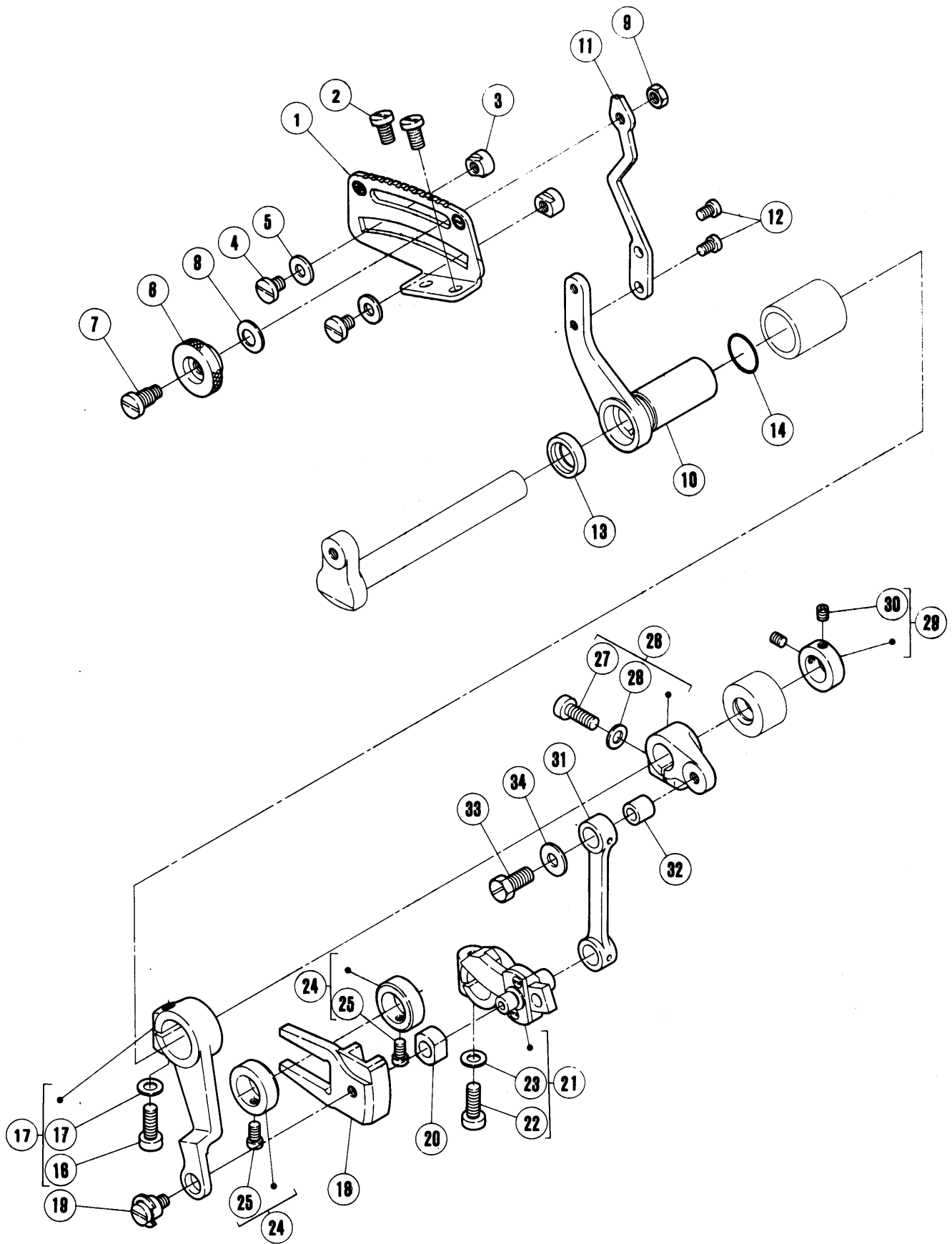

上送り機構(2)

TOP FEED MECHANISM(2)

REF. NO.	PART NO. 部品番号	名称	NAME	QT.
1	212416	調節板	BLADE GUIDE	1
2	5117	平ネジ / C 5	SCREW	2
3	210171	ストッパ	STOPPER	2
4	2905	平ネジ / C 5	SCREW	2
5	201185	座金	WASHER	2
6	210167	ツマミ	THUMB NUT	1
7	5486	段付ネジ / C 5	SCREW	1
8	211301	皿バネ	SPRING	1
9	3044	六角ナット / C 5	NUT	1
10	212042	調節レバー	LEVER	1
11	212419	レバー / 調節	LEVER	1
12	5053	平ネジ / C 4	SCREW	2
13	204052A	オイルシール	OIL SEAL	1
14	201022	Oリング	O RING	1
15	212652	調節レバー	LEVER	1
16	5594	平ネジ / C 7	SCREW	1
17	307003	座金	WASHER	1
18	212651	角駒案内	GUIDE/BLOCK	1
19	5316	段付ネジ / C 5	SCREW	1
20	252531	角駒	BLOCK	1
21	212646	クランク (組)	CRANK ASSEMBLY	1
22	5594	平ネジ / C 7	SCREW	1
23	307003	座金	WASHER	1
24	212653	カラ	COLLAR	2
25	1998-2	平ネジ / C 4	SCREW	2
26	212035	クランク	CRANK	1
27	5594	平ネジ / C 7	SCREW	1
28	307003	座金	WASHER	1
29	212039	カラ	COLLAR	1
30	5292	止ネジ / C 3	SCREW	2
31	212650	リンク	LINK	1
32	210148	ブッシュ	BUSHING	1
33	5489	六角ネジ / C 5	SCREW	1
34	204115	座金	WASHER	1

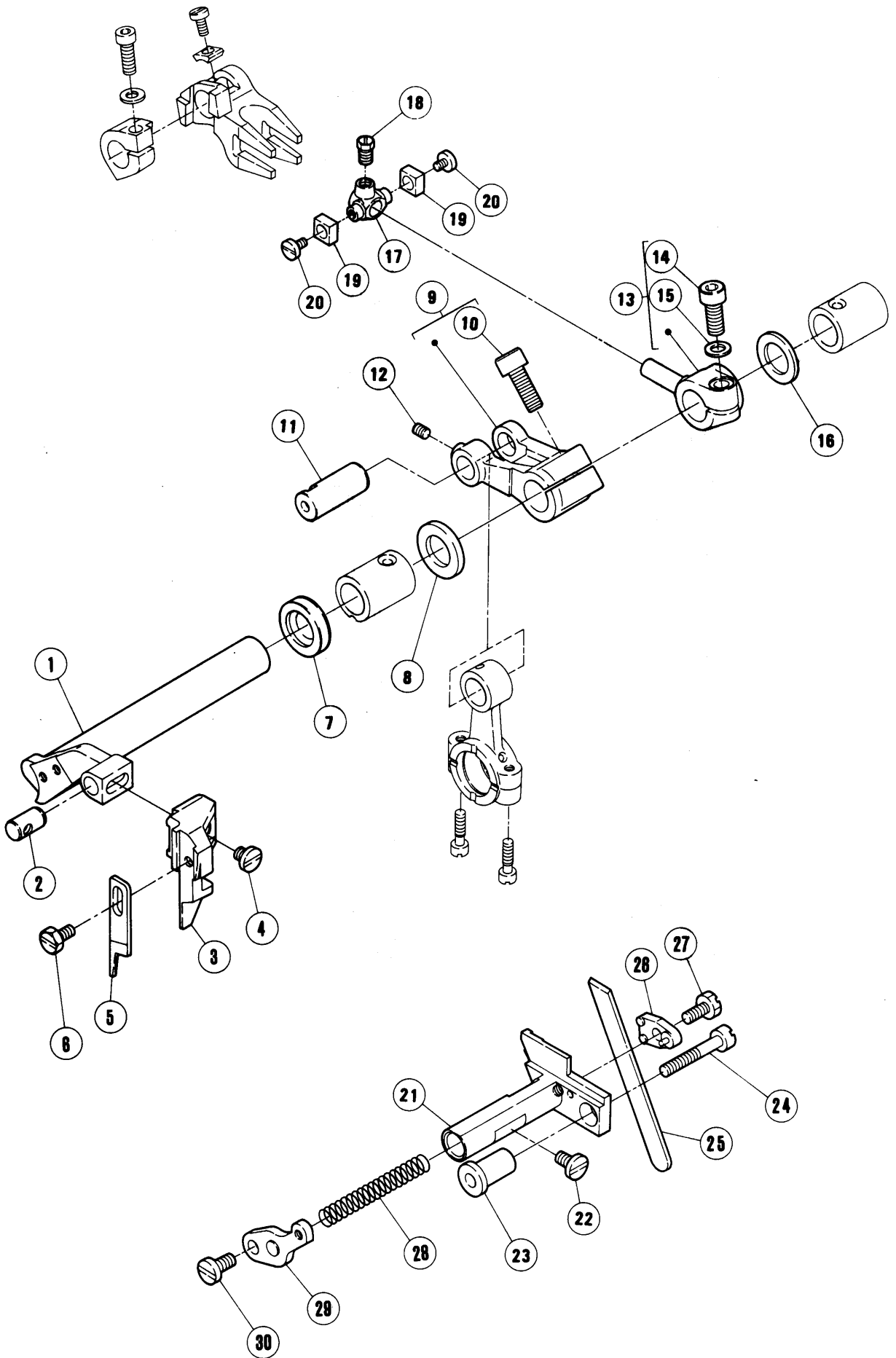

上下メス機構

KNIFE DRIVE MECHANISM

REF. NO.	PART NO. 部品番号	名称	NAME	QT.
1	213222A	上メス台	UPPER KNIFE LEVER	1
2	208579	平行ピン	PIN	1
3	210315B	上メス抱キ	UPPER KNIFE CLAMP	1
4	2902	平ネジ / C 5	SCREW	1
5	201121A	上メス	UPPER KNIFE	1
6	5088	六角ネジ / C 4	SCREW	1
7	210069	オイルシール	OIL SEAL	1
8	206180	座金	WASHER	1
9	210314	クランク / 上メス	CRANK/UPPER KNIFE DRIVE	1
10	5457	平ネジ / C 9	SCREW	1
11	210175	平行ピン	PIN	1
12	5461	止ネジ / C 5	SCREW	1
13	212408	クランク	CRANK	1
14	5594	平ネジ / C 7	SCREW	1
15	307003	座金	WASHER	1
16	208235	座金	WASHER	1
17	212409	クランクピン	PIN	1
18	5084	六角ネジ / C 5	SCREW	1
19	212410	六角駒	BLOCK	2
20	5597	平ネジ / C 1	SCREW	2
21	210316	下メス台	LOWER KNIFE HOLDER	1
22	4009-1	平ネジ / C 5	SCREW	1
23	210180	案内 / 下メス台	GUIDE/LOWER KNIFE HOLDER	1
24	5094	平ネジ / C 5	SCREW	1
25	202295	下メス / 厚メス	LOWER KNIFE/THICK	1
26	210184	下メス押エ	CLAMP/LOWER KNIFE	1
27	2193	六角ネジ / C 5	SCREW	1
28	202340	圧縮バネ	SPRING	1
29	210183	下メスバネ受け	SPRING RETAINER	1
30	5117	平ネジ / C 5	SCREW	1

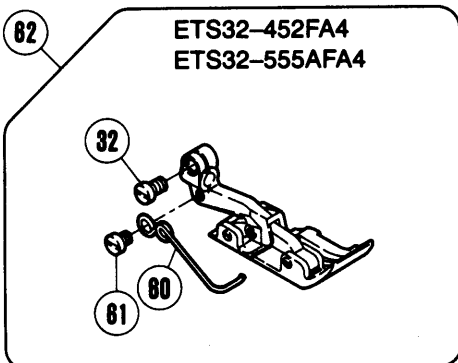
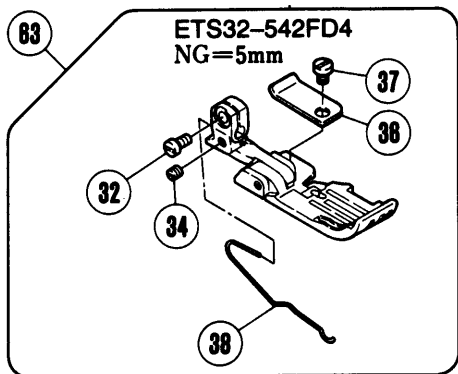
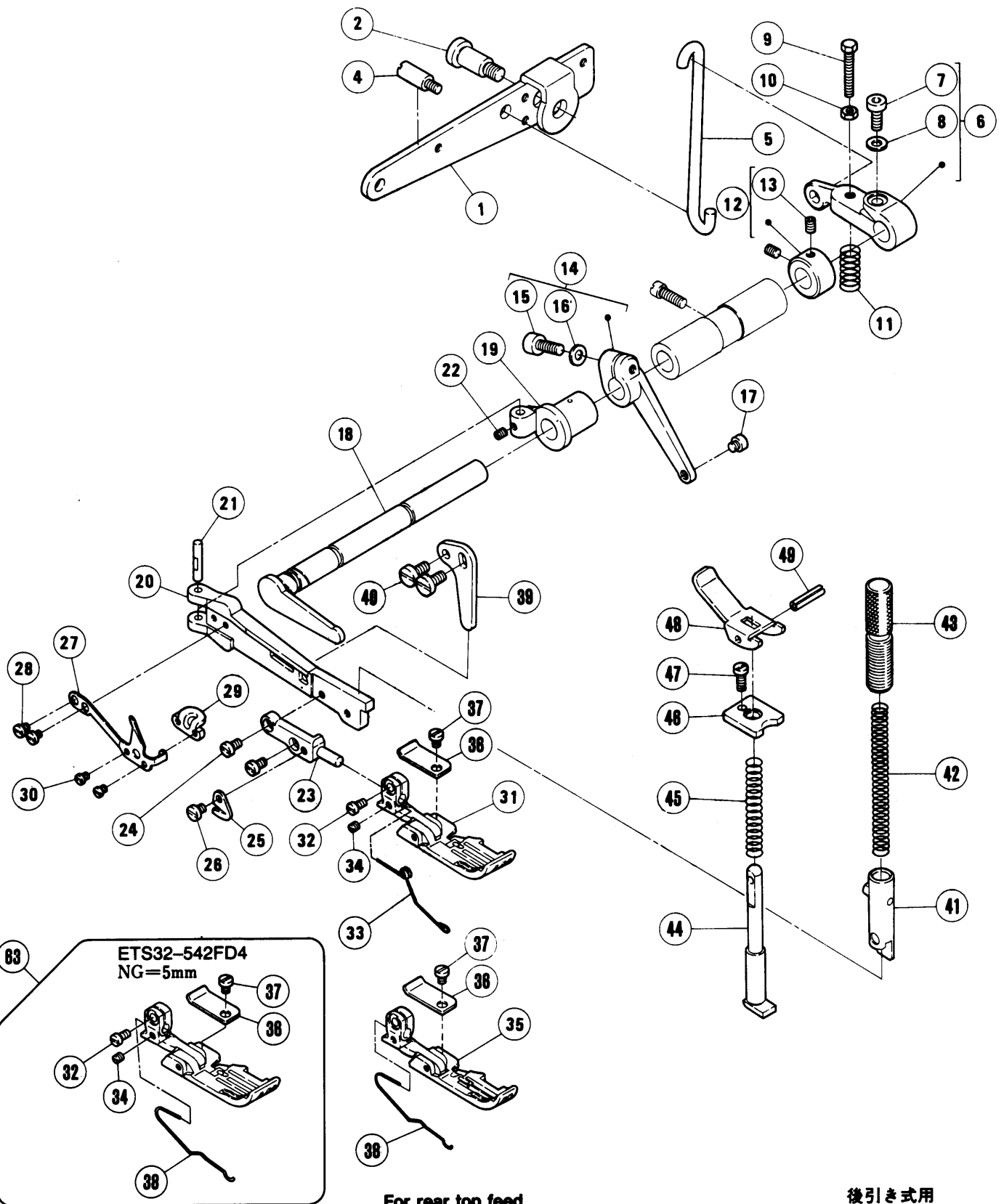

For rear top feed

後引き式用

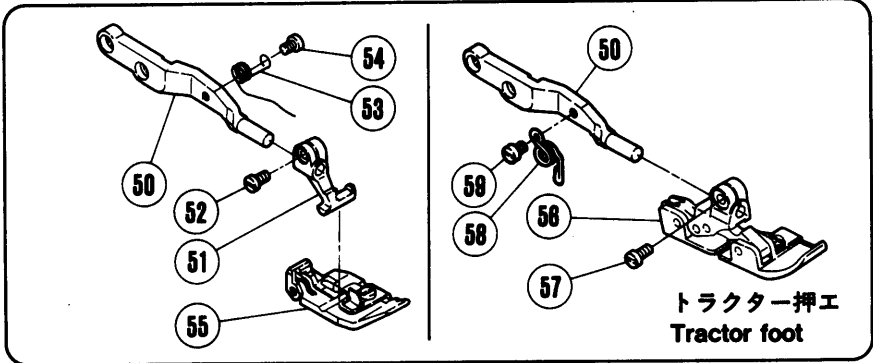

NG=Needle Gauge
NG=針 巾

REF. NO.	PART NO. 部品番号	名称	NAME	QT.
1	211636	レバー / 足揚ゲ	LEVER/FOOT LIFT	1
2	2285B	段付ネジ / C 9	SCREW	1
4	5481	ピン付ネジ / C 5	SCREW	1
5	210335	リンク / 足揚ゲレバー	LINK/FOOT LIFT LEVER	1
6	212050	レバー / 押エ揚ゲ	LEVER/FOOT LIFT	1
7	5457	平ネジ / C 9	SCREW	1
8	207924	座金	WASHER	1
9	5503	六角ネジ / C 5	SCREW	1
10	3044	六角ナット / C 5	NUT	1
11	240172	圧縮バネ	SPRING	1
12	210728	カラージ	COLLAR	1
13	5292	止ネジ / C 3	SCREW	2
14	212052	レバー / 押エ揚ゲ	LEVER/FOOT LIFT	1
15	5594	平ネジ / C 7	SCREW	1
16	307003	座金	WASHER	1
17	5596	ピン付ネジ / C 4	SCREW	1
18	212047	軸 / 押エ台	SHAFT/FOOT LIFT	1
19	212049	ピン付ネジ / 押エ台	HINGE/PRESSER ARM	1
20	211823	押エ台	PRESSER ARM	1
21	210323	平行ピン	PIN	1
22	5292	止ネジ / C 3	SCREW	1
23	212420	押エブラケット	BRACKET/PRESSER FOOT	1
24	5089	平ネジ / C 3	SCREW	2
25	202451	チェーンカッター	CHAIN CUTTER	1
26	2921	平ネジ / C 3	SCREW	1
27	212438	板バネ	FLAT SPRING	1
28	5299	平ネジ / C 3	SCREW	2
29	212439	当金	GUIDE	1
30	5030	平ネジ / C 1	SCREW	2
31	XXXXXX	押エ (組)	PRESSER FOOT ASSEMBLY	1
32	5328	平ネジ / C 4	SCREW	1
33	212669	ネジリバネ	SPRING	1
34	1459	止ネジ / C 4	SCREW	1
35	XXXXXX	押エ (組)	PRESSER FOOT ASSEMBLY	1
36	212668	補助板	EUXILIARY PLATE	1
37	5030	平ネジ / C 1	SCREW	1
38	212719	ネジリバネ	SPRING	1
39	210517	ストッパー / 押エ台	STOPPER/PRESSER ARM	1
40	5117	平ネジ / C 5	SCREW	1
41	208537	押エ棒 (組)	PRESSER BAR COMPLETE	1
42	211941	圧縮バネ	SPRING	1
43	208774	調節ネジ	THUMB SCREW	1
44	202645	手揚軸	PLUNGER	1
45	201395	圧縮バネ	SPRING	1
46	208599	案内板	BUSHING	1
47	5029	平ネジ / C 5	SCREW	1
48	211657	手揚ゲ	LEVER/HAND LIFT	1
49	202647A	スプリングピン	PIN	1
50	212705	ブラケット / 押エ	BRACKET/PRESSER FOOT	1
51	212062	ホルダー	HOLDER	1
52	5328	平ネジ / C 4	SCREW	1
53	212063	ネジリバネ	SPRING	1
54	2921	平ネジ / C 3	SCREW	1
55	XXXXXX	押エ (組)	PRESSER FOOT ASSEMBLY	1
56	XXXXXX	押エ (組)	PRESSER FOOT ASSEMBLY	1
57	5328	平ネジ / C 4	SCREW	1
58	211517	ネジリバネ	SPRING	1
59	2921	平ネジ / C 3	SCREW	1
60	212923	ネジリバネ	SPRING	1
61	2921	平ネジ / C 3	SCREW	1
62	XXXXXX	押エ (組)	PRESSER FOOT ASSEMBLY	1
63	XXXXXX	押エ (組)	PRESSER FOOT ASSEMBLY	1

××××××は、58~102頁参照。

See pages 58~102 for ××××××.

■ 新型ポンプ

機械番号 8613290 以降のミシン(1987年7月以降に生産)には
 新型ポンプが使用されています。

■ PLEASE NOTE:

The machines (after the machine number 8613290)
 which are manufactured from July, 1987.

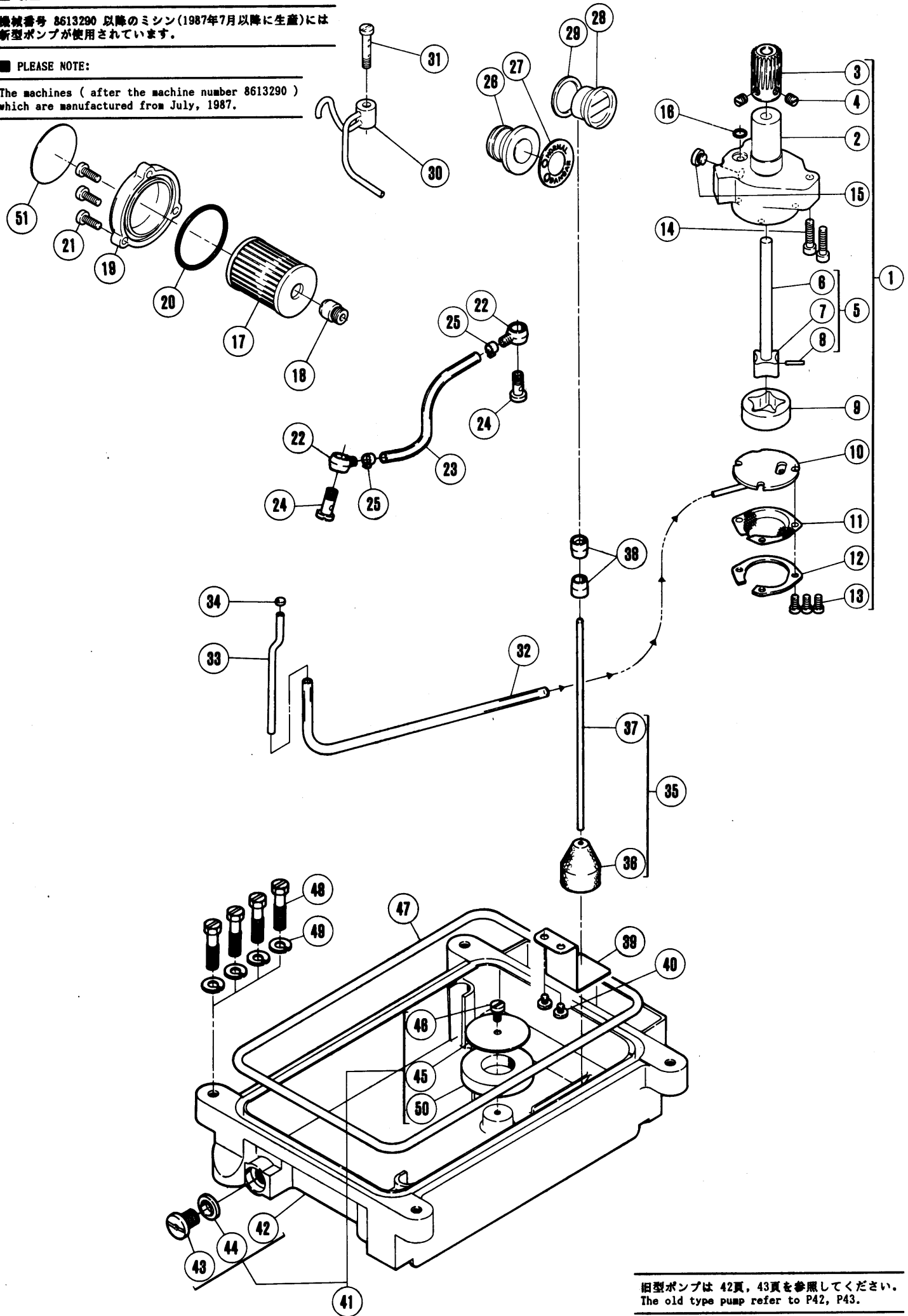

旧型ポンプは 42頁, 43頁を参照してください。
 The old type pump refer to P42, P43.

給油機構

LUBRICATING MECHANISM

REF. NO.	PART NO. 部品番号	名称	NAME	QT.
1	212972A91	ポンプ (組)	TROCHOID PUMP ASSEMBLY	1
2	212976	ポンプ本体	TROCHOID PUMP	1
3	211531	ウォームホイール	WORM WHEEL	1
4	5060	止ネジ / C 8	SCREW	2
5	212978-91	ローター (内) 軸	ROTOR (INSIDE) SHAFT	1
6	212979	軸	SHAFT	1
7	212980	ローター (内)	ROTOR (INSIDE)	1
8	206468	平行ピン	PIN	1
9	212981	ローター (外)	ROTOR (OUTSIDE)	1
10	212983-91	側板	PLATE	1
11	213578A	フィルター	FILTER	1
12	213579	当金	GUIDE	1
13	1175-2	平ネジ / C 4	SCREW	3
14	5095	平ネジ / C 5	SCREW	2
15	5145	平ネジ / C 10	SCREW	1
16	204185	Oリング	O RING	1
17	206233	エレメント	OIL FILTER	1
18	210200	ブラケット / フィルター	BRACKET/OIL FILTER	1
19	210201-FD	フィルター蓋	OIL FILTER CAP	1
20	206431	Oリング	O RING	1
21	5118	平ネジ / C 5	SCREW	3
22	200136	継手	JOINT	2
23	205113A	給油パイプ	OIL TUBE	1
24	200152	継手ネジ	JOINT SCREW	2
25	202199	クランプ	CLAMP	2
26	210198	給油標示 (組)	OIL MONITOR COMPLETE	1
27	210199	銘板 / 給油標示	NAME PLATE/OIL MONITOR	1
28	210190	オイルゲージ	OIL SIGHT GAUGE	1
29	211369	座金	WASHER	1
30	212188	噴油管	OIL DISTRIBUTOR	1
31	212998	継手ネジ	JOINT SCREW	1
32	212152	チューブ	TUBE	1
33	212153	パイプ	PIPE	1
34	303487	フェルト	FELT	1
35	210193	オイル指示 (組)	INDICATOR COMPLETE	1
36	210191	フロート	FLOAT	1
37	210192	オイル指示	INDICATOR	1
38	210194	案内 / オイル指示	INDICATOR GUIDE	2
39	210510	オイル指示受	INDICATOR SUPPORT	1
40	2905	平ネジ / C 5	SCREW	2
41	212634	オイルパン (組)	OIL RESERVOIR COMPLETE	1
42	210211	オイルパン	OIL RESERVOIR	1
43	5138B	平ネジ / H 1 1	SCREW	1
44	202287A	ガスケット	GASKET	1
45	210521	マグネット台座	MAGNET BRACKET	1
46	5117	平ネジ / C 5	SCREW	1
47	210212	Oリング	O RING	1
48	5113	平ネジ / C 5	SCREW	4
49	202045	バネ座金	SPRING WASHER	4
50	210520	マグネット	MAGNET	1
51	9A3002	フィルターシール	FILTER SEAL	1

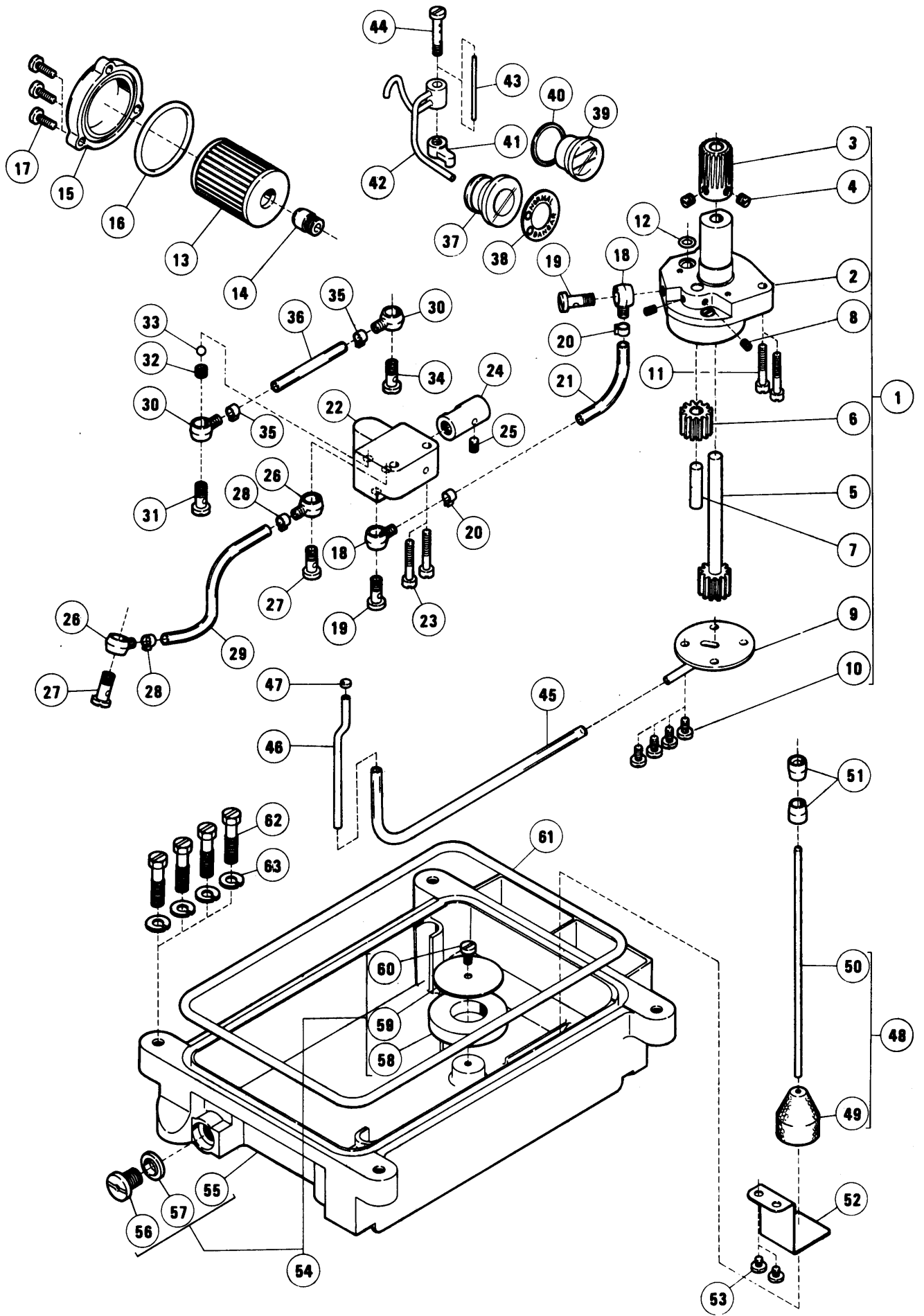

給油機構(旧タイプ)

LUBRICATING MECHANISM (OLD TYPE)

REF. NO.	PART NO. 部品番号	名称	NAME	QT.
1	212148	ポンプ(組)	OIL PUMP ASSEMBLY	1
2	210188	ポンプ本体	GEAR PUMP	1
3	211531	ウォームホイール	WORM WHEEL	1
4	5060	止ネジ/C 8	SCREW	2
5	208687	ポンプギヤ-(A)	GEAR	1
6	201295	ギヤ-	GEAR	1
7	204184	軸/ギヤ-	GEAR SHAFT	1
8	1458	止ネジ/C 5	SCREW	2
9	212149	側板	CASING PLATE	1
10	5117	平ネジ/C 5	SCREW	4
11	5095	平ネジ/C 5	SCREW	2
12	204185	Oリング	O RING	1
13	206233	エレメント	OIL FILTER	1
14	210200	ブラケット/フィルター	BRACKET/OIL FILTER	1
15	210201-FD	フィルター蓋	OIL FILTER CAP	1
16	206431	Oリング	O RING	1
17	5118	平ネジ/C 5	SCREW	3
18	200136	継手	JOINT	2
19	200152	継手ネジ	JOINT SCREW	2
20	202199	クランプ	CLAMP	2
21	210701	チューブ	OIL TUBE	1
22	210206	バイパス台	BY-PASS BLOCK	1
23	5095	平ネジ/C 5	SCREW	2
24	205635	バイパス弁(組)	BY-PASS VALVE ASSEMBLY	1
25	1458	止ネジ/C 5	SCREW	1
26	200136	継手	JOINT	2
27	200152	継手ネジ	JOINT SCREW	2
28	202199	クランプ	CLAMP	2
29	205763	チューブ	OIL TUBE	1
30	200136	継手	JOINT	2
31	200152	継手ネジ	JOINT SCREW	1
32	210744	逆止弁弁座	POST	1
33	200144	ボール	BALL	1
34	200152	継手ネジ	JOINT SCREW	1
35	202199	クランプ	CLAMP	2
36	210208	ボール	TUBE	1
37	210198	給油標示(組)	OIL MONITOR COMPLETE	1
38	210199	銘板/給油標示	NAME PLATE/OIL MONITOR	1
39	210190	オイルゲージ	OIL SIGHT GAUGE	1
40	211369	座金	WASHER	1
41	210202	給油ブロック	LUBRICATION BLOCK	1
42	212188	給油管	OIL DISTRIBUTOR	2
43	210205	平行ピン	PIN	1
44	210204	継手ネジ	JOINT SCREW	1
45	212152	チューブ	TUBE	1
46	212153	パイプ	PIPE	1
47	303487	フェルト	FELT	1
48	210193	オイル指示(組)	INDICATOR COMPLETE	1
49	210191	フロート	FLOAT	1
50	210192	オイル指示	INDICATOR	1
51	210194	案内/オイル指示	INDICATOR GUIDE	2
52	210510	オイル指示受	INDICATOR SUPPORT	1
53	2905	平ネジ/C 5	SCREW	2
54	212634	オイルパン(組)	OIL RESERVOIR COMPLETE	1
55	210211	オイルパン	OIL RESERVOIR	1
56	5138B	平ネジ/H 1 1	SCREW	1
57	202287A	ガスケット	GASKET	1
58	210520	マグネット	MAGNET	1
59	210521	マグネット台座	MAGNET BRACKET	1
60	5117	平ネジ/C 5	SCREW	1
61	210212	Oリング	O RING	1
62	5113	平ネジ/C 5	SCREW	4
63	202045	バネ座金	SPRING WASHER	4

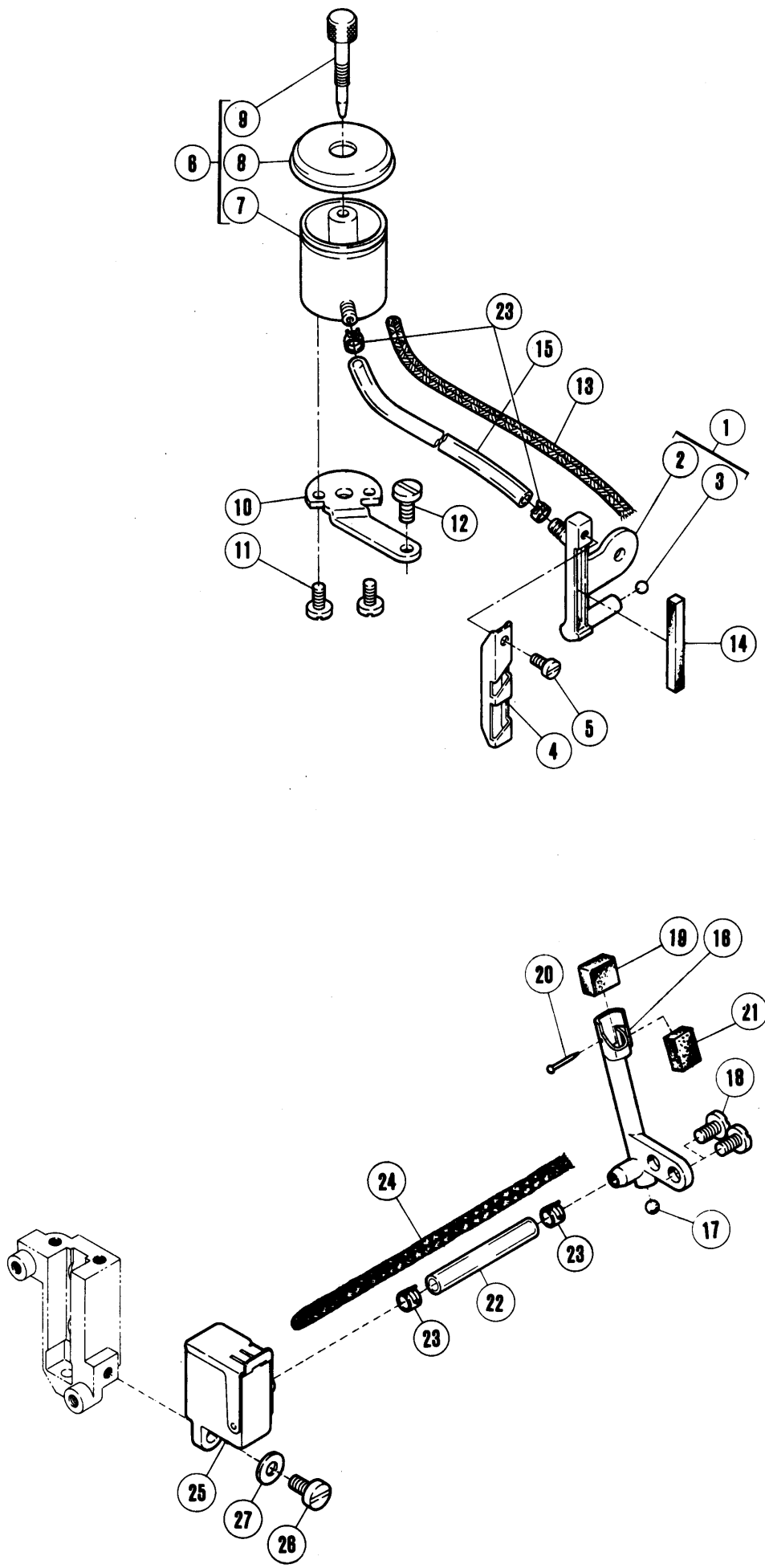

H.R.装置

H.R. DEVICE

REF. NO.	PART NO. 部品番号	名称	NAME	QT.
1	212635-ME	針冷却器 (組)	NEEDLE COOLER ASSEMBLY	1
2	211315	針冷却器	NEEDLE THREAD LUBRICATOR	1
3	240097	栓	PLUG	1
4	211316	糸案内	THREAD GUIDE	1
5	1202	平ネジ / C 4	SCREW	1
6	205897-91	シリコンタンク (上) 組	SILICONE OIL RESERVOIR (UPPER)	1
7	202476-1	シリコンタンク (上)	SILICONE OIL RESERVOIR (UPPER)	1
8	202476-4	蓋	CAP	1
9	202476-3	油量調節棒	SILICONE OIL REGULATOR	1
10	211317	ブラケット	BRACKET	1
11	1202	平ネジ / C 4	SCREW	2
12	5117	平ネジ / C 5	SCREW	1
13	202176	給油紐	OIL WICK	1
14	211318	フェルト	OIL FELT	1
15	211319	チューブ	OIL TUBE	1
16	210317	針冷却器	NEEDLE COOLER	1
17	210214	栓	PLUG	1
18	5091	平ネジ / C 5	SCREW	2
19	204466	給油フェルト	OIL WICK	1
20	210766	止ピン	PIN	1
21	240178	給油フェルト	OIL FELT	1
22	211639	チューブ	OIL TUBE	1
23	200155	クランプ	TUBE CLAMP	4
24	202176	給油紐	OIL WICK	1
25	210539	シリコンタンク (下) 組	SILICONE OIL RESERVOIR (LOWER)	1
26	5345	平ネジ / C 5	SCREW	1
27	201185	座金	WASHER	1

- ① ETS32-FD
- ② ETS32-FD4/P1,P2

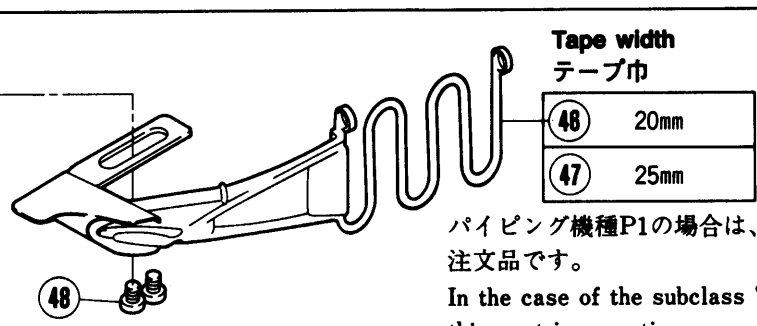
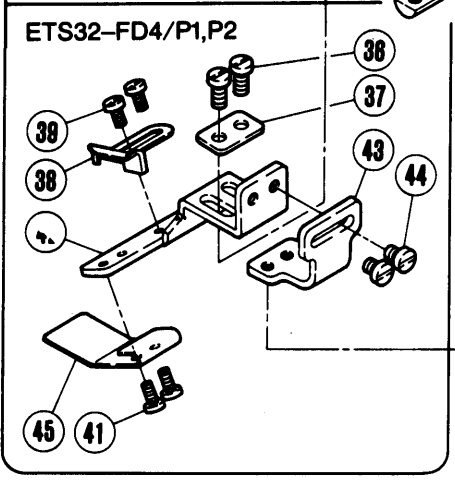
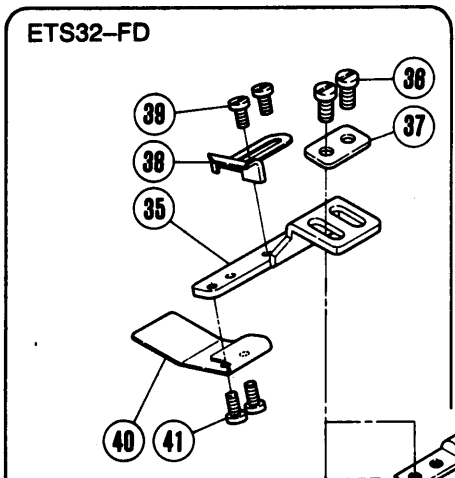
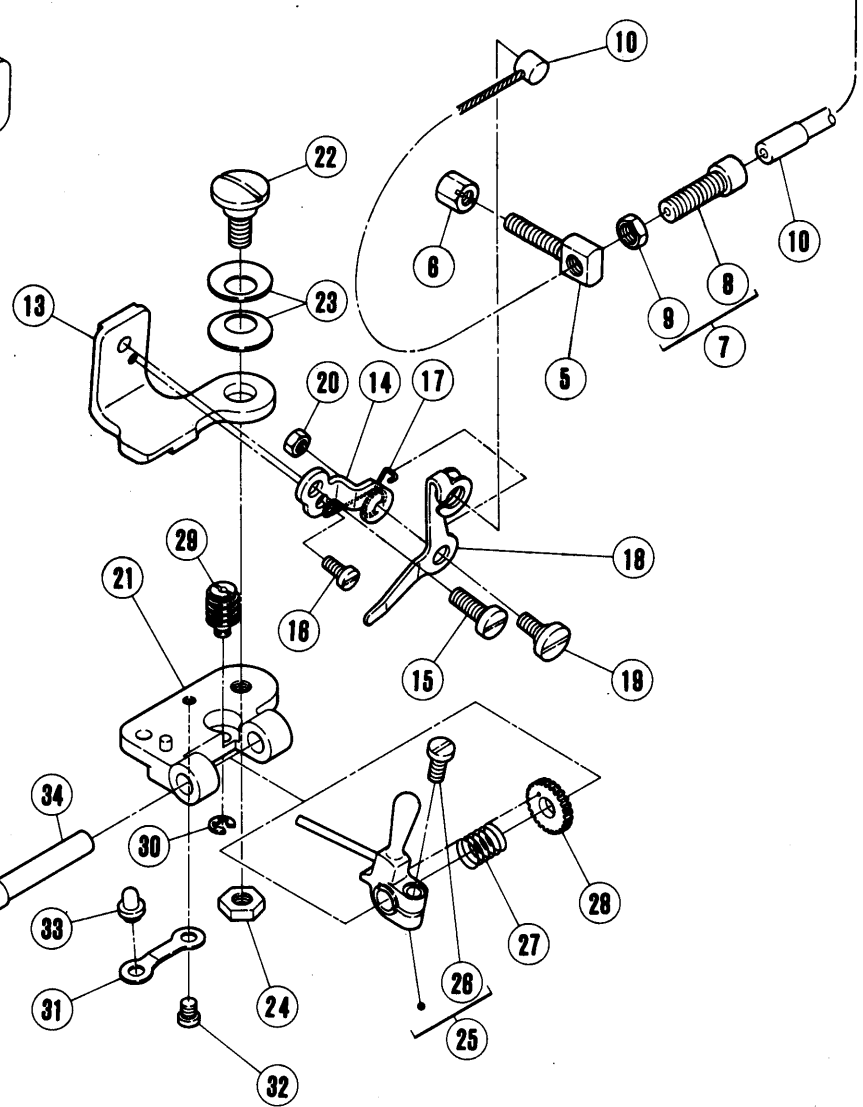
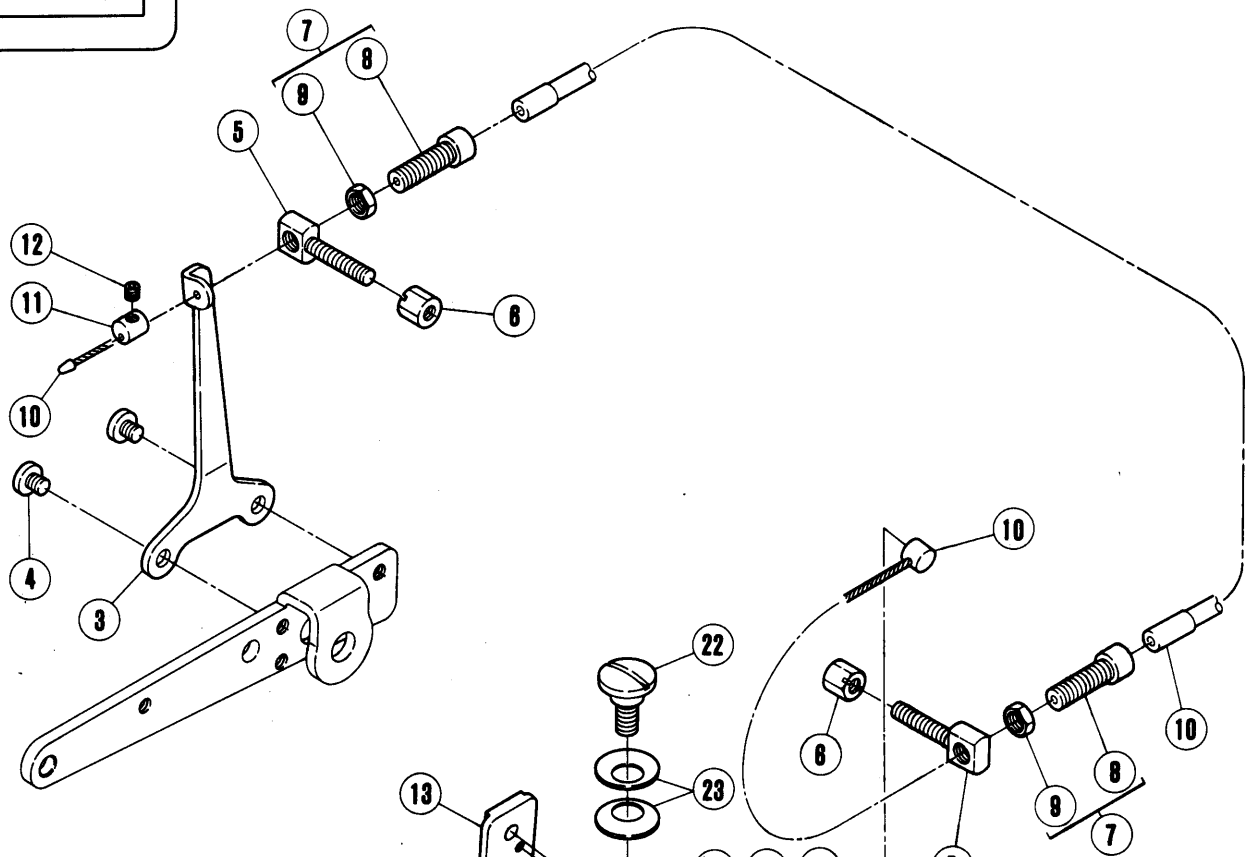

Tape width
テープ巾

④⑧	20mm
④⑦	25mm

パイピング機種P1の場合は、
注文品です。
In the case of the subclass "P1",
this part is an option.

ヒダ取り装置

SHIRRING ATTACHMENT

REF. NO.	PART NO. 部品番号	名称	NAME	QT.
1	212655	ヒダ取り装置 (組)	SHIRRING ATTACHMENT COMPLETE	1
2	212655A91	ヒダ取り装置 (組)	SHIRRING ATTACHMENT COMPLETE	1
3	212433	レバー	LEVER	1
4	2905	平ネジ / C 5	SCREW	2
5	212437	ブラケット	BRACKET	2
6	5111	六角ネジ / C 5	SCREW	2
7	212436	ケーブル受ケ	CABLE SUPPORT	2
8	212477	ケーブル受ケ	CABLE SUPPORT	2
9	4806	六角ナット / M 6	NUT	2
10	212435	ケーブル	CABLE	1
11	212434	ストッパー	STOPPER	1
12	1459	止ネジ / C 4	SCREW	1
13	212600	ブラケット	BRACKET	1
14	212430	ブラケット	BRACKET	1
15	5118	平ネジ / C 5	SCREW	1
16	5328	平ネジ / C 4	SCREW	1
17	212432	線細工バネ	SPRING	1
18	212431	レバー	LEVER	1
19	5515	段付ネジ / C 4	SCREW	1
20	3091	六角ナット / C 4	NUT	1
21	212601	ブラケット	BRACKET	1
22	5380	段付ネジ / C 8	SCREW	1
23	204888	皿バネ	SPRING	2
24	5104	六角ナット / C 8	NUT	1
25	212604	レバー	LEVER	1
26	1175-2	平ネジ / C 4	SCREW	1
27	212606	ネジリバネ	SPRING	1
28	212607	ギヤ	GEAR	1
29	212602	ウォーム	WORM	1
30	200555	止メ輪	RING	1
31	210684	板バネ	FLAT SPRING	1
32	1234	平ネジ / C 4	SCREW	1
33	210683	段付ピン	PIN	1
34	212603	軸	ROD	1
35	212659	ブラケット	BRACKET	1
36	1196	平ネジ / C 3	SCREW	2
37	210955	座金	WASHER	1
38	212660	布ガイド	CLOTH GUIDE	1
39	5077	平ネジ / C 1	SCREW	2
40	212658	プレート	SHIRRING BLADE	1
41	5077	平ネジ / C 1	SCREW	2
42	212938	ブラケット	BRACKET	1
43	212939	ブラケット	BRACKET	1
44	2921	平ネジ / C 3	SCREW	2
45	212658A	プレート	SHIRRING BLADE	1
46	211880	バインダー (20)	BINDER (20)	1
47	211946	バインダー (25)	BINDER (25)	1
48	2921	平ネジ / C 3	SCREW	2

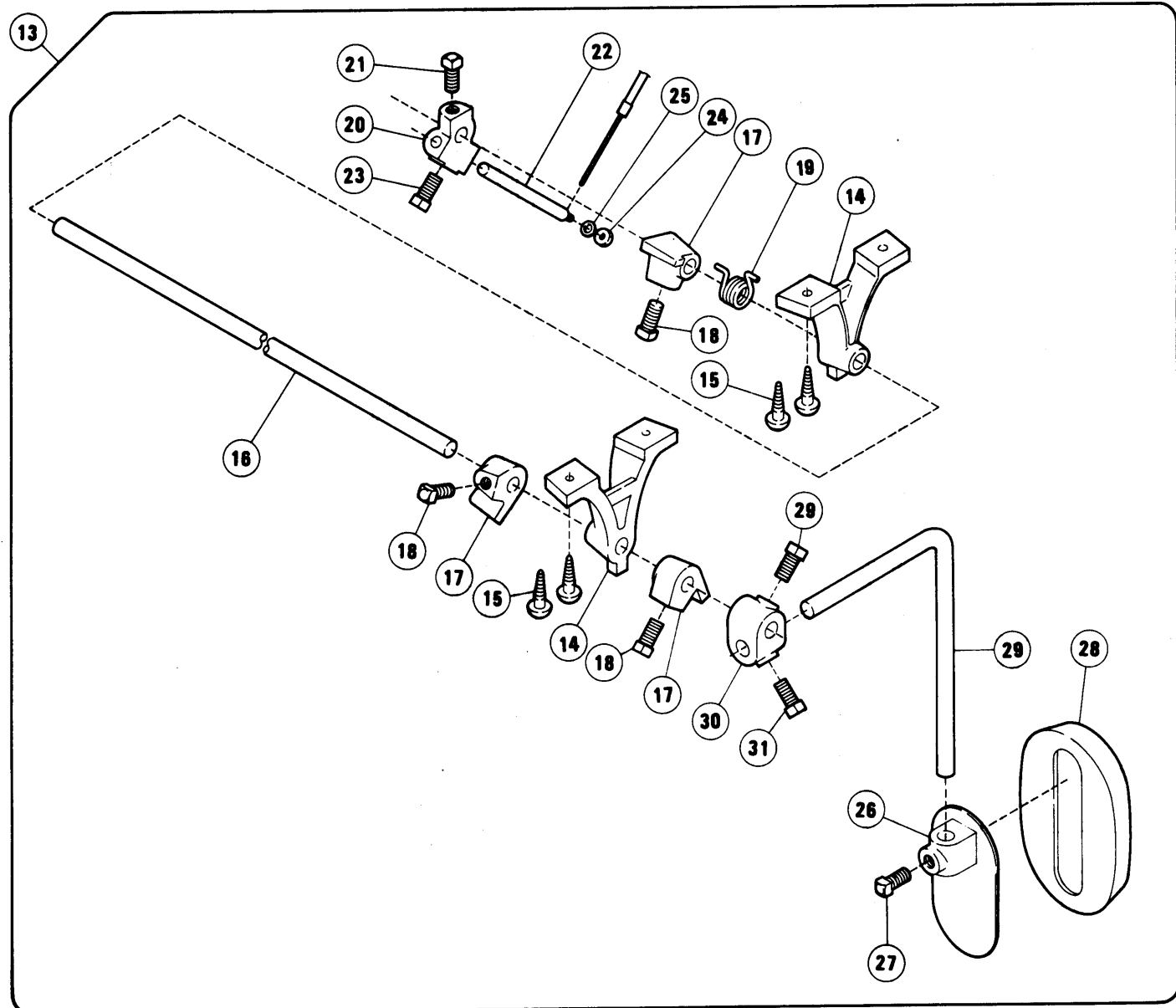
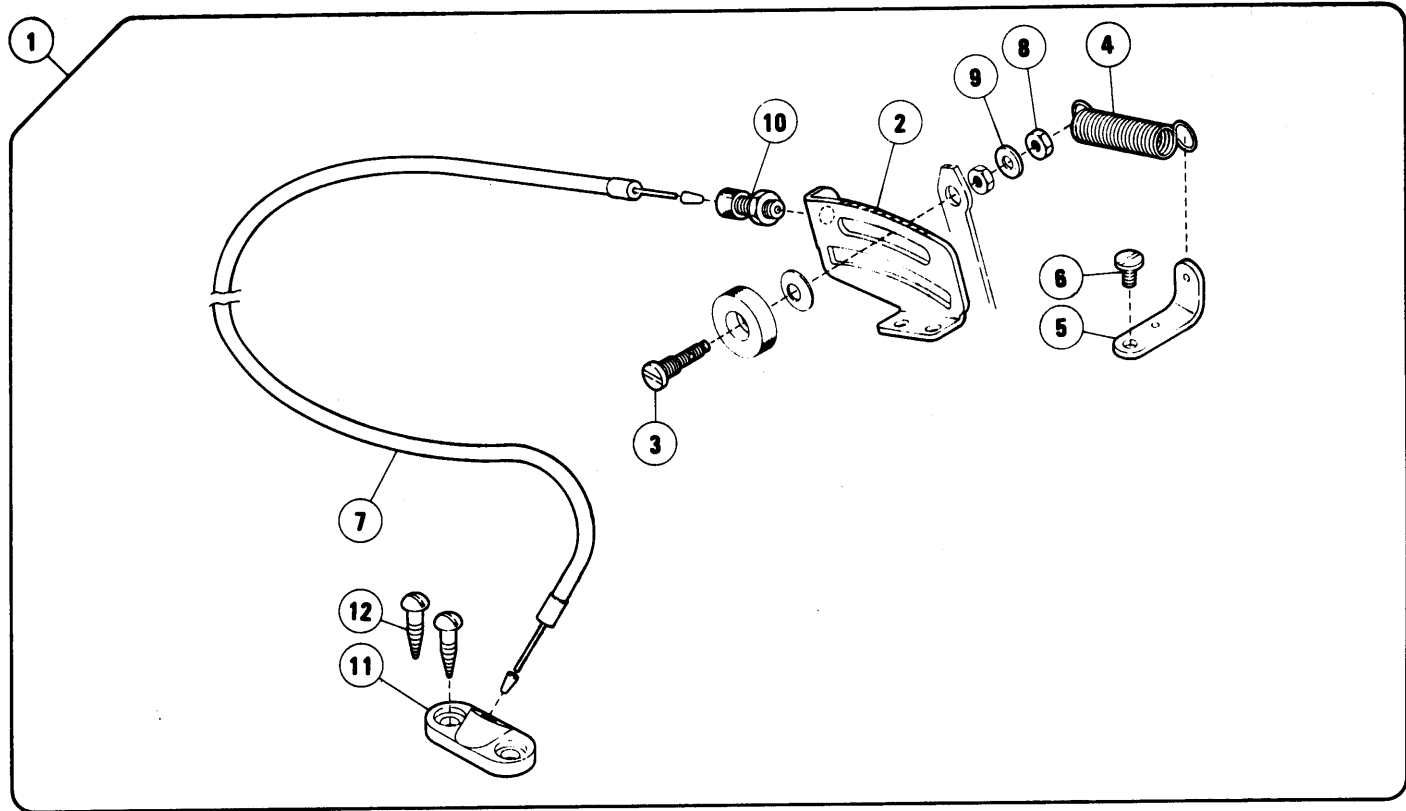

KL100途中いせ込み装置

KL100 INTERMITTENT ATTACHMENT

REF. NO.	PART NO. 部品番号	名称	NAME	QT.
1	212478	インターミッテント装置	INTERMITTENT ATTACHMENT	1
2	212479	調節板	BLADE GUIDE	1
3	212480	段付ネジ	SCREW	1
4	212481	引張りバネ	SPRING	1
5	212482	ラッチ	LATCH	1
6	4009-1	平ネジ / C 5	SCREW	1
7	212483	ケーブル	CABLE	1
8	3044	六角ナット / C 5	NUT	1
9	204585	座金	WASHER	1
10	212436	ケーブル受け	CABLE SUPPORT	1
11	212484	ブラケット	BRACKET	1
12	4906	木ネジ (平) / 4. 8	SCREW	2
13	212487	ヒザ駆動装置 (組)	KNEE LIFTER ASSEMBLY	1
14	207341-JA	フレーム	FRAME	2
15	4906	木ネジ (平) / 4. 8	SCREW	4
16	212485	軸	ROD	1
17	207344-JA	カラー	COLLAR	3
18	5543	四角ボルト / W 5	BOLT	3
19	209287	ネジリバネ	SPRING	1
20	207350-JA	ブラケット	BRACKET	1
21	5543	四角ボルト / W 5	BOLT	1
22	212486	レバー	LEVER	1
23	5543	四角ボルト / W 5	BOLT	1
24	4805	六角ナット / M 5	NUT	1
25	202058	座金	WASHER	1
26	207345-JA	ヒザ当て	KNEE PAD BASE	1
27	5543	四角ボルト / W 5	BOLT	1
28	207346	ヒザ当てカバー	KNEE PAD	1
29	212492	軸	ROD	1
30	212493-JA	ブラケット	BRACKET	1
31	5543	四角ボルト / W 5	BOLT	2

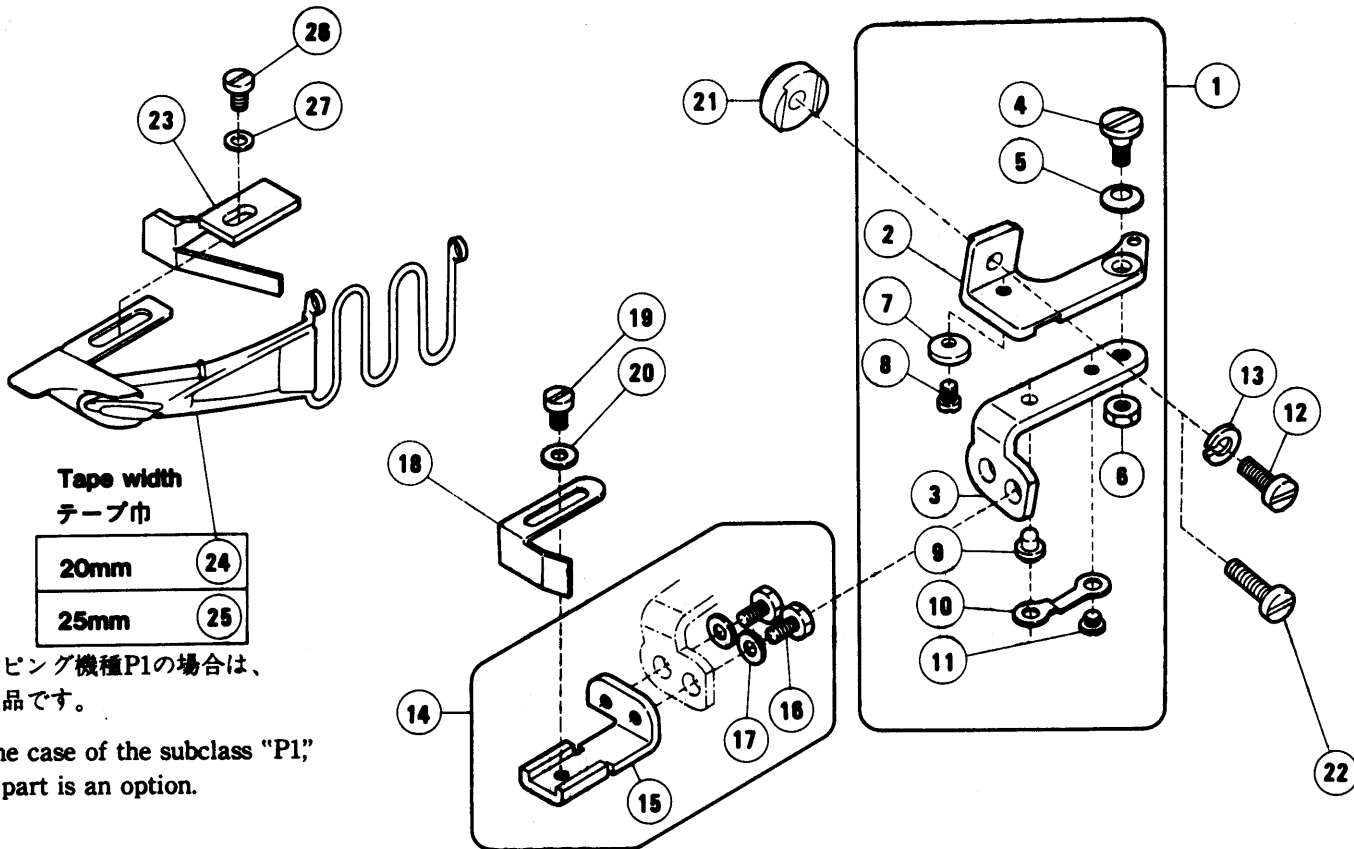

パイピング機種P1の場合は、
注文品です。

In the case of the subclass "P1,"
this part is an option.

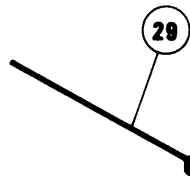
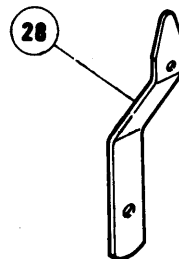
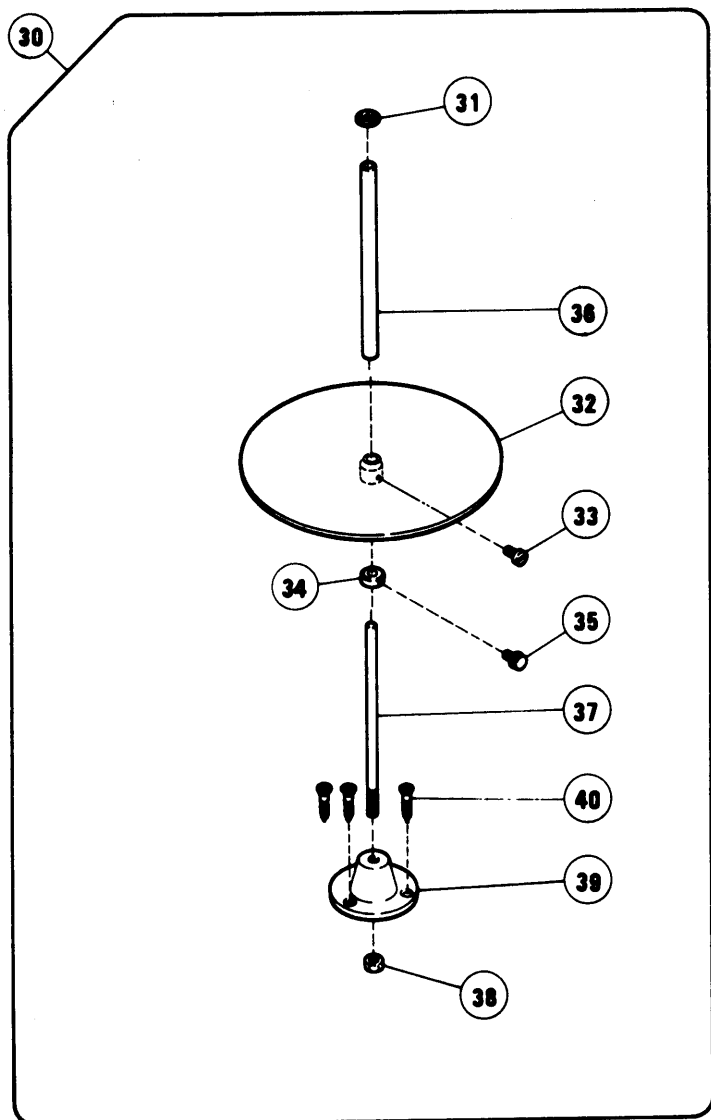

パイピング機種P1の場合は、
注文品です。

In the case of the subclass "P1,"
this part is an option.

REF. NO.	PART NO. 部品番号	名称	NAME	QT.
1	210685	定規ブラケット (組)	CLOTH GUIDE BRACKET ASSEMBLY	1
2	210680	定規ブラケット	CLOTH GUIDE BRACKET	1
3	210681	ヒンジ/定規ブラケット	HINGE/EDGE GUIDE BRACKET	1
4	5184	段付ネジ / C 5	SCREW	1
5	201191	皿バネ	SPRING	1
6	3044	六角ナット / C 5	NUT	1
7	210682	ストッパー / ヒンジ	STOPPER	1
8	5053	平ネジ / C 4	SCREW	1
9	210683	段付ピン	PIN	1
10	210684	板バネ	FLAT SPRING	1
11	2906	平ネジ / C 4	SCREW	1
12	5118	平ネジ / C 5	SCREW	1
13	202286	バネ座金	SPRING WASHER	1
14	210686	当定規台 (組)	BRACKET COMPLETE/EDGE GUIDE	1
15	210687	当定規台 (組)	BRACKET COMPLETE/EDGE GUIDE	1
16	5088	六角ネジ / C 4	SCREW	2
17	167066	座金	WASHER	2
18	201233A	当定規	EDGE GUIDE	1
19	1202	平ネジ / C 4	SCREW	1
20	167066	座金	WASHER	1
21	212287	スペーサー	SPACER	1
22	5152	平ネジ / C 5	SCREW	1
23	211879	当定規	EDGE GUIDE	1
24	211880	バインダー (20)	BINDER (20)	1
25	211946	バインダー (25)	BINDER (25)	1
26	1202	平ネジ / C 4	SCREW	1
27	167066	座金	WASHER	1
28	211949	案内板	CORD GUIDE PLATE	1
29	413	テープ通シ具	TAPE INSERTING TOOL	1
30	403	テープガイド (組)	TAPE DISC ASSEMBLY	1
31	406	フェルト	FELT	1
32	404	カノコ台	TAPE DISC	1
33	4012	平ネジ / M 4	SCREW	1
34	407	カラージ	COLLAR	1
35	408	調節ネジ	ADJUSTING SCREW	1
36	405	取付棒	FIXING ROD	1
37	409	軸	SHAFT	1
38	4818	六角ナット / M 6	NUT	1
39	410	ブラケット	BRACKET	1
40	4908	木ネジ (皿) / 4. 5	SCREW	3

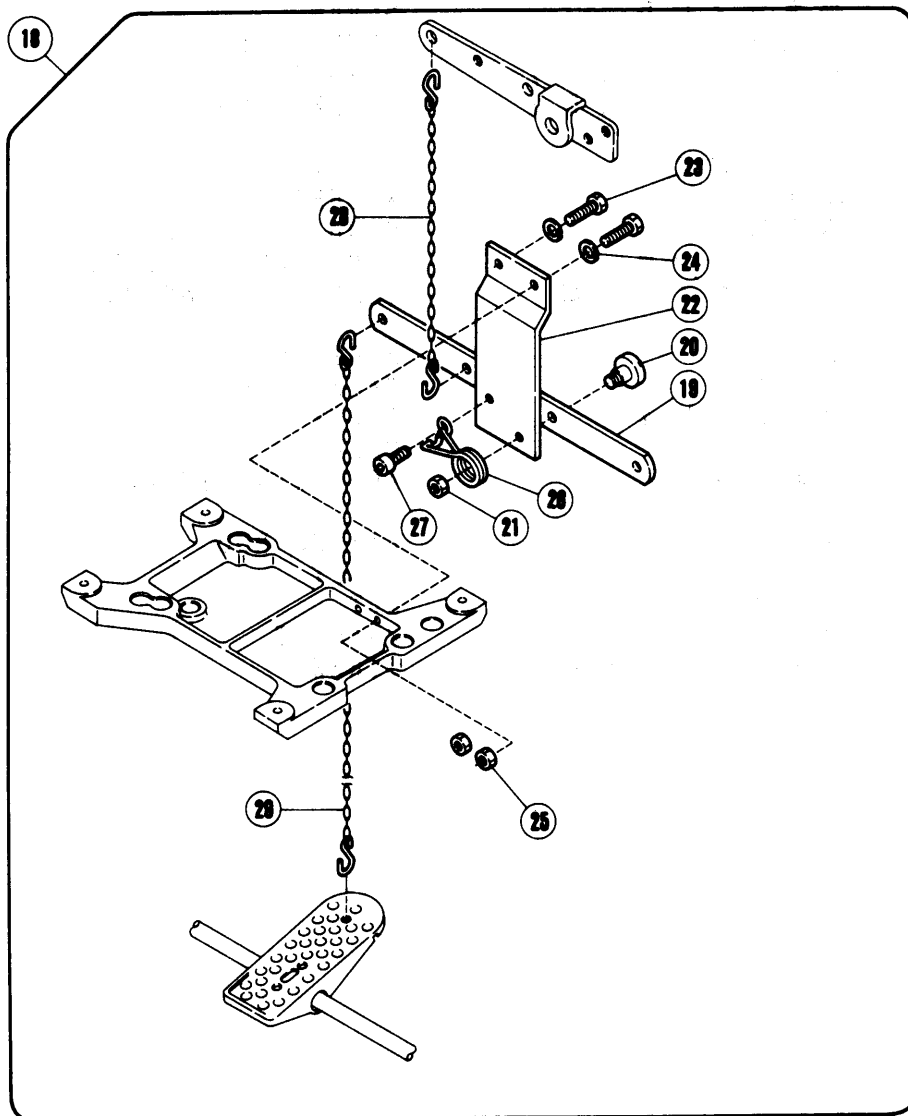
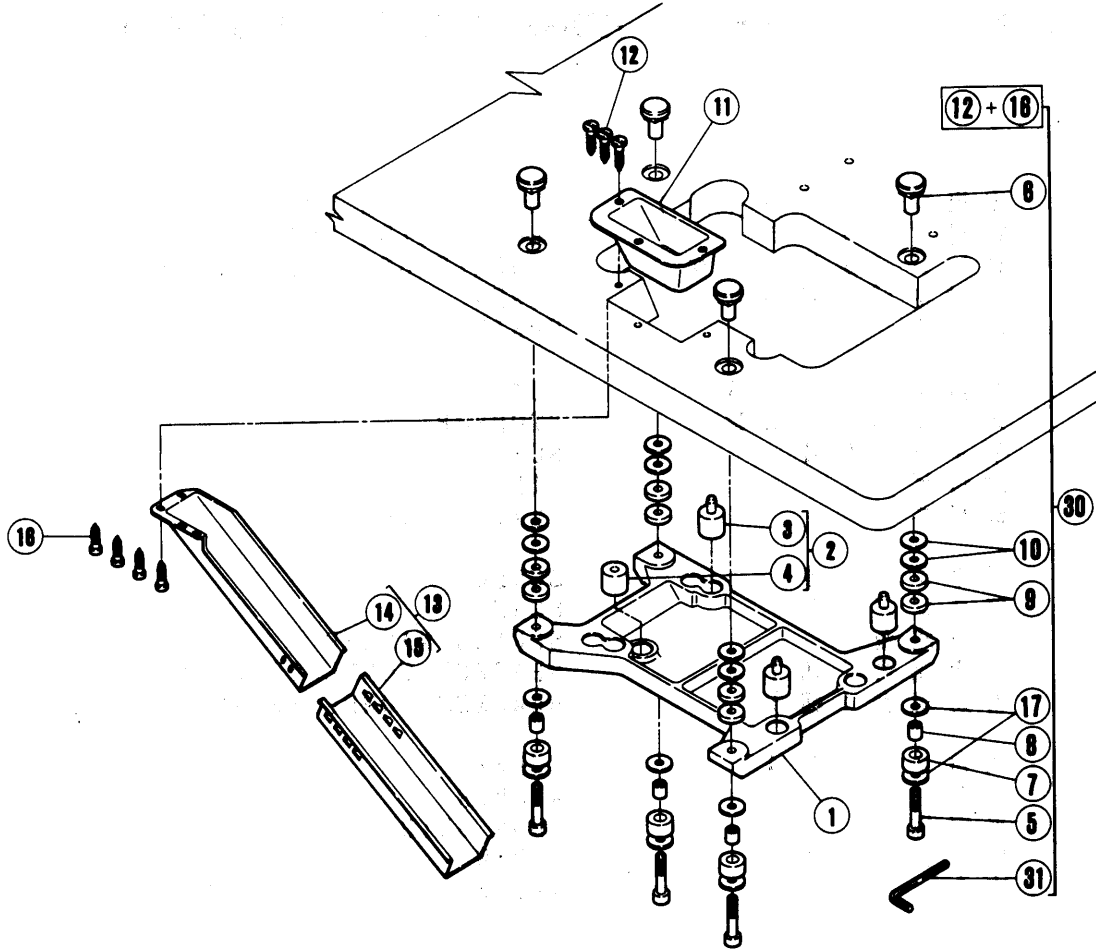

据付付属品

PARTS FOR SEMI-SUBMERGED INSTALLATION

REF. NO.	PART NO. 部品番号	名称	NAME	QT.
1	205466A	マシン据付板	MACHINE REST BOARD	1
2	9029	防振ゴム (セット)	CUSHION RUBBER (SET)	1
3	205473	防振ゴム	CUSHION RUBBER	3
4	210523	防振ゴム	CUSHION RUBBER	1
5	4512	平ネジ / M 8	SCREW	4
6	206336	半沈用ナット	NUT	4
7	205764	防振ゴム	CUSHION RUBBER	4
8	205765	ライナー	LINER	4
9	205467	スペーサー	SPACER	8
10	206337	座金	WASHER	8
11	205470-JA	切屑受	WASTE CHUTE TOP	1
12	4904	木ネジ (皿) / 3.5	SCREW	3
13	9050	切屑受 (セット)	WASTE CHUTE SET	1
14	205468-JA	切屑受	WASTE CHUTE TOP	1
15	205469-JA	切屑受 (B)	WASTE CHUTE TOP (B)	1
16	4906	木ネジ (平) / 4.8	SCREW	4
17	206337	座金	WASHER	8
18	212441	押エ揚ゲ (組)	FOOT LIFTER ASSEMBLY	1
19	212442	レバー	LEVER	1
20	5380	段付ネジ / C 8	SCREW	1
21	5104	六角ナット / C 8	NUT	1
22	212443	ブラケット	BRACKET	1
23	5276	六角ネジ / C 7	SCREW	2
24	303067	バネ座金	SPRING WASHER	2
25	5426	六角ナット / C 7	NUT	2
26	212444	ネジリバネ	SPRING	1
27	5534	平ネジ / C 8	SCREW	1
28	470	鎖	CHAIN	1
29	471	鎖	CHAIN	1
30	9030	ボルト (セット)	BOLT SET	1
31	272	キーレンチ / 6 M M	ALLEN KEY/6MM	4

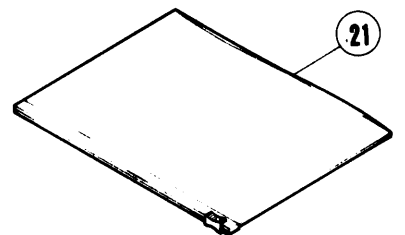
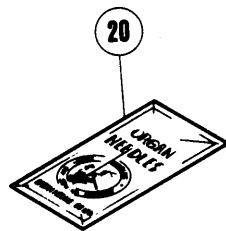
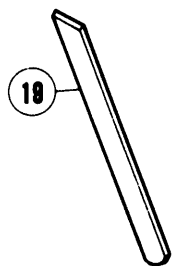
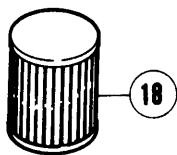
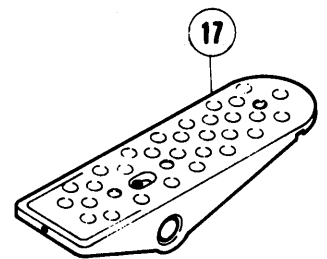
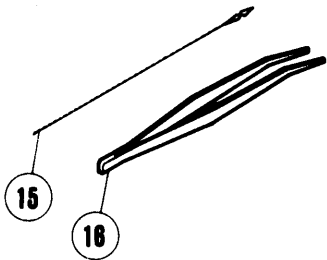
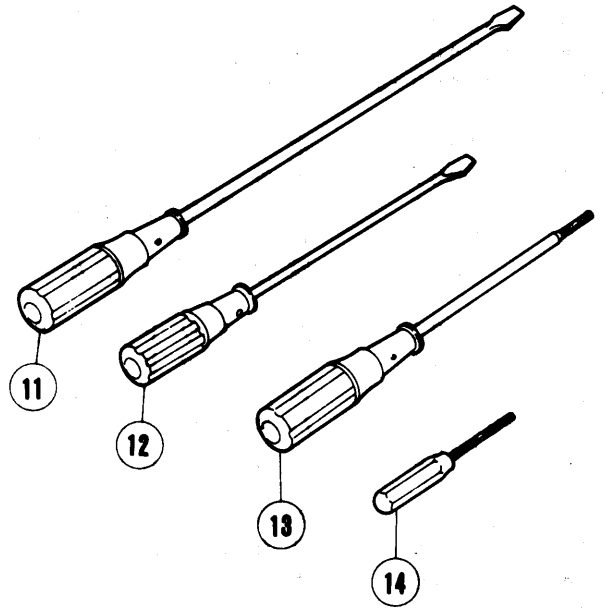
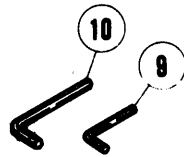
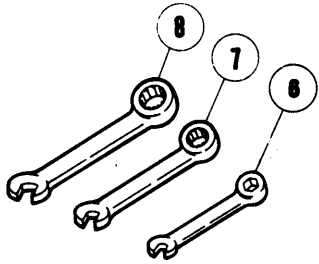
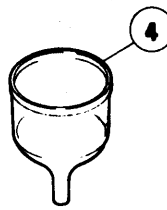
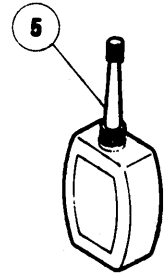
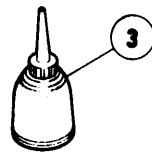
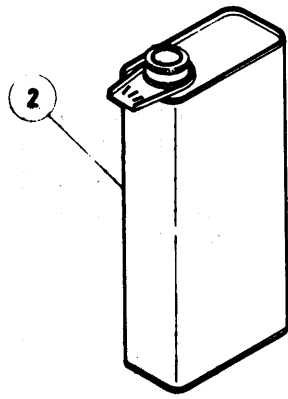
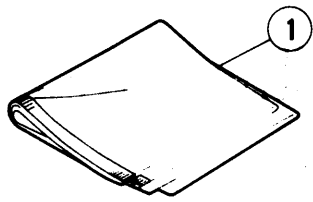

付属品

ACCESSORIES

REF. NO.	PART NO. 部品番号	名称	NAME
1	908	ナイロンカバー (中)	DUST COVER
2	453	油缶 / 1000CC	OIL CONTAINER/1000CC
3	485	油差シ	OILER
4	484	ジョウゴ	OIL FUNNEL
5	178	シリコンオイル / 50CC	CONTAINER - SILICONE
6	282	スパナ / 5MM	WRENCH/5MM
7	284	スパナ / 7MM	WRENCH/7MM
8	285	スパナ / 8MM	WRENCH/8MM
9	322	キーレンチ / 2.38MM	ALLEN KEY/2.38MM
10	200	キーレンチ / 4.76MM	ALLEN KEY/4.76MM
11	127	ドライバ (大)	SCREWDRIVER (LARGE)
12	128	ドライバ (中)	SCREWDRIVER (MEDIUM)
13	414	キーレンチドライバ	ALLEN KEY DRIVER/3.17MM
14	179	キーレンチドライバ	ALLEN KEY DRIVER
15	153	糸通シ具	THREADING WIRE
16	131	ピンセット	TWEEZERS
17	478	ペダル	PEDAL
18	206233	エレメント	OIL FILTER
19	202295	下メス / 厚メス	LOWER KNIFE/THICK
20	XXXXXX	針	NEEDLE
21	482	アクセサリバッグ	ACCESSORY BAG

××××××は、58~102頁参照。

See pages 58~102 for ××××××.

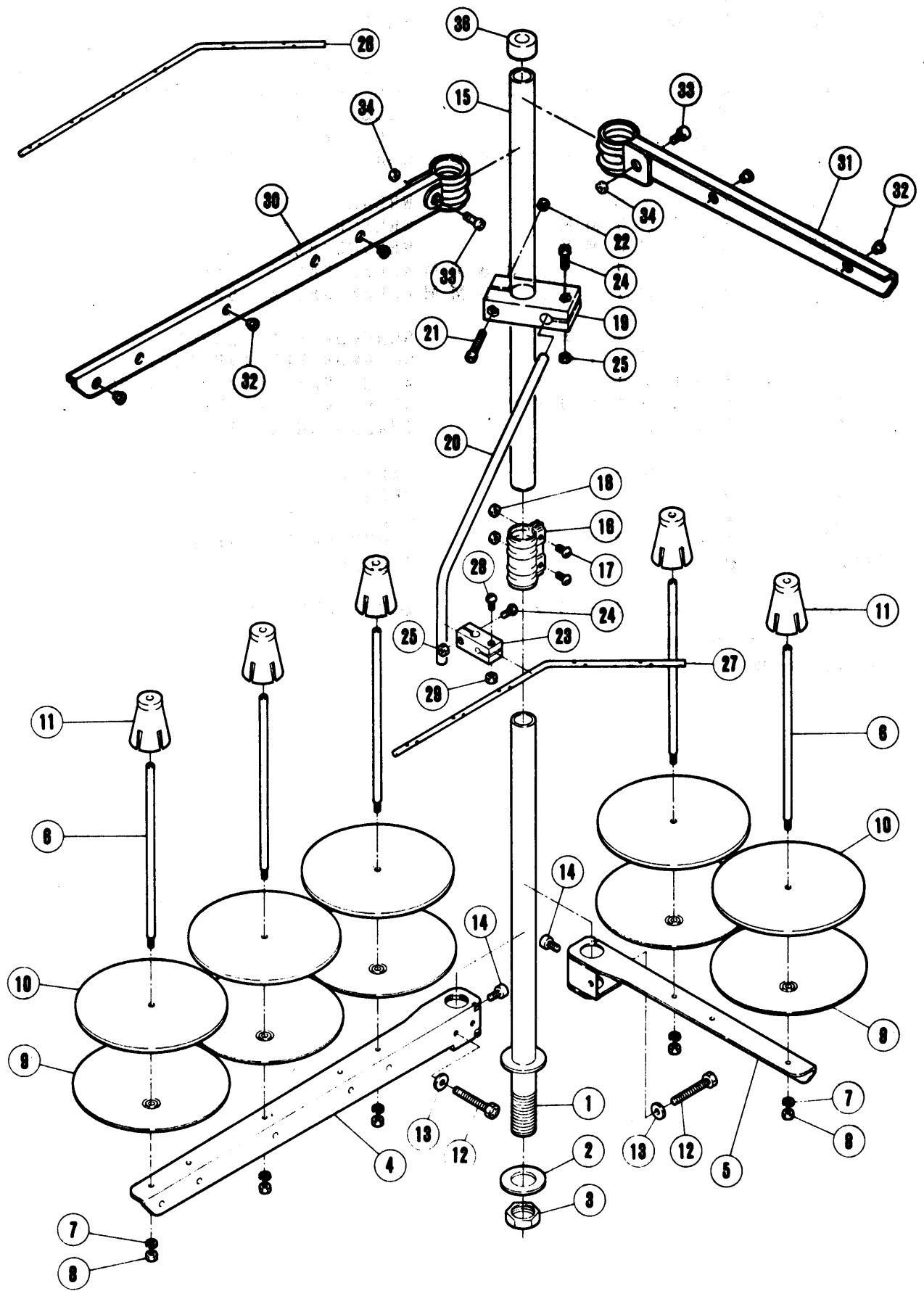

REF. NO.	PART NO. 部品番号	名称	NAME	QT.
	486-9C	糸立 (組) (6本立)	THREAD STAND ASS. (6-SPOOLS)	1
	486A9C	糸立 (組) (5本立)	THREAD STAND ASS. (5-SPOOLS)	1
1	503-CA	スタンド棒 (下)	THREAD STAND ROD (LOWER)	1
2	509	座金	WASHER	1
3	5476	六角ナット	NUT	1
4	505-CA	ブラケット (3本立)	BRACKET	1
5	505ACA	ブラケット (2本立)	BRACKET	1
6	380A	糸立棒	SPOOL PIN	5
7	201252	バネ座金	SPRING WASHER	5
8	4803	六角ナット / M 4	NUT	5
9	381-CA	受皿	SPOOL TRAY	5
10	507	ウレタン	CUSHION	5
11	382-CA	ユレ止メ	SPOOL RETAINING FIN	5
12	7102	六角ネジ / M 6	SCREW	2
13	512	座金	WASHER	2
14	4022	平ネジ / M 6	SCREW	2
15	502-CA	スタンド棒 (上)	THREAD STAND ROD (UPPER)	1
16	504-CA	ジョイント	JOINT	1
17	4021	平ネジ / M 5	SCREW	2
18	4805	六角ナット / M 5	NUT	2
19	383-CA	ブラケット	BRACKET	1
20	384	糸道棒腕	THREAD GUIDE BAR ROD	1
21	4014	平ネジ / M 4	SCREW	1
22	4803	六角ナット / M 4	NUT	1
23	233-CA	ホルダー	HOLDER	1
24	4012	平ネジ / M 4	SCREW	2
25	4803	六角ナット / M 4	NUT	2
26	293	糸道棒	THREAD GUIDE BAR	1
27	293A	糸道棒 (5本立)	THREAD GUIDE BAR (5-SPOOLS)	1
28	4012	平ネジ / M 4	SCREW	1
29	4803	六角ナット / M 4	NUT	1
30	527-CA	ブラケット (3本立)	BRACKET	1
31	527ACA	ブラケット (2本立)	BRACKET	1
32	506	糸目穴	THREAD EYELET	5
33	4117	平ネジ / M 5	SCREW	2
34	4805	六角ナット / M 5	NUT	2
36	386	キャップ	ROD CAP	1

ETS32-420FA2/516-413
ETS32-422FA2/516-313

ETS32-430FA2/516-433
ETS32-430FA2A/516-433
ETS32-434FA2/516-333

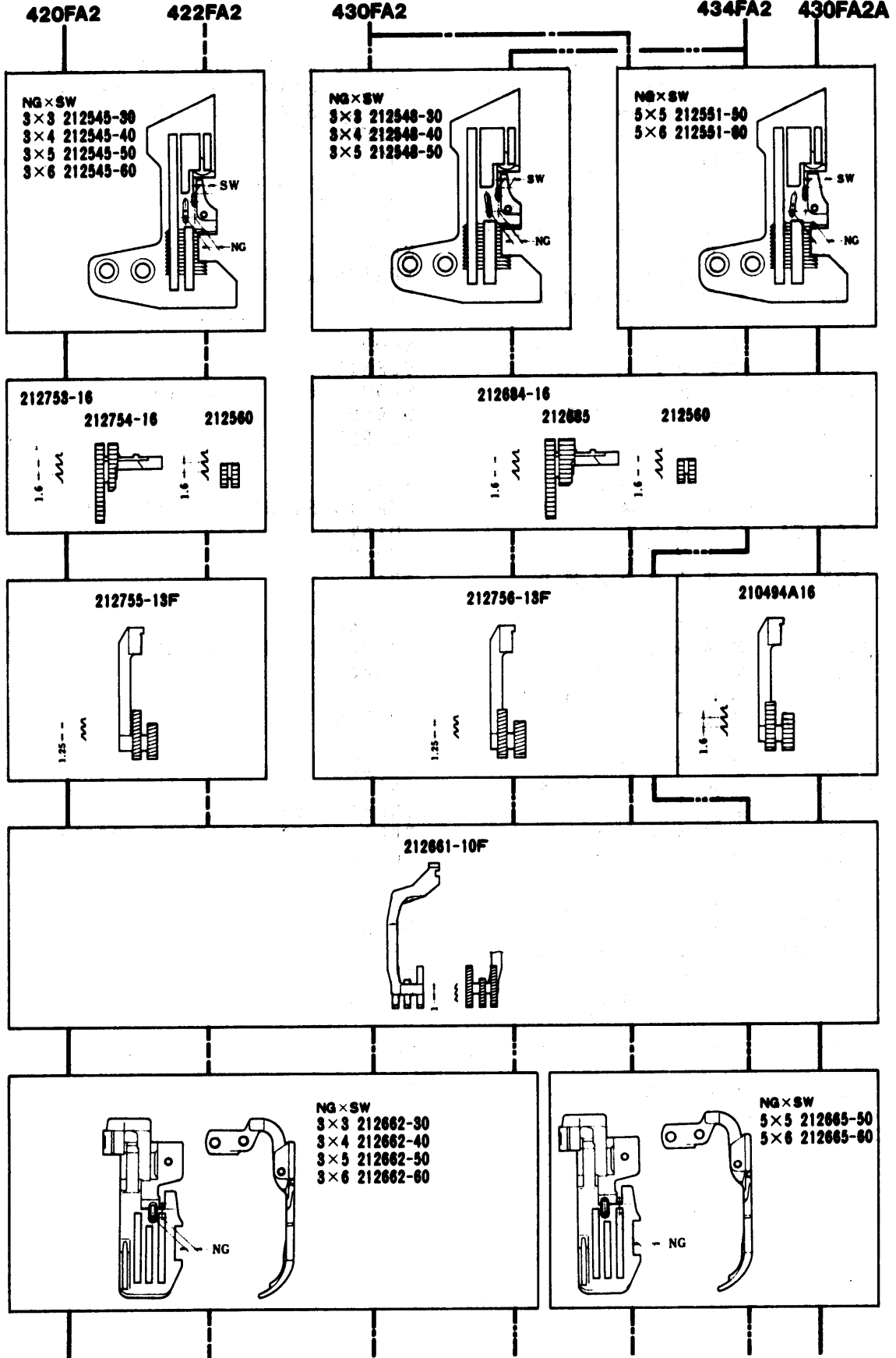





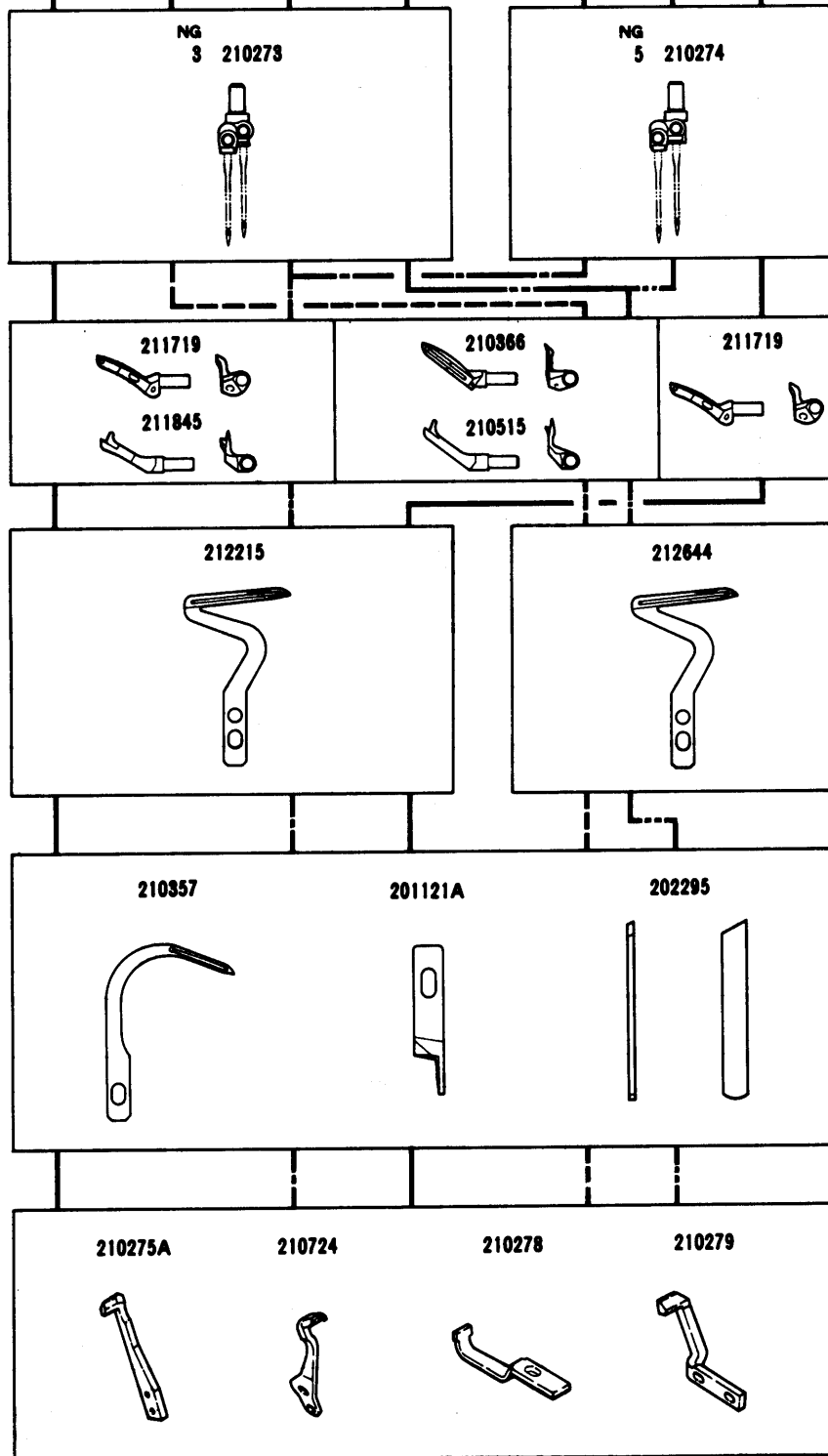







NG=NEEDLE GAUGE 針巾
SW=SEAM WIDTH 縫巾

420FA2 422FA2 430FA2 434FA2 430FA2 434FA2 430FA2A



地縫(薄物~中厚物用)

SEAMING (Light to medium)

											
ETS32-420FA2 /516-413 515	3	3,4,5,6	3.8	0.7~1.5	0.7~2	EX	6,000	スラックス、パジャマ	Pants, pajamas		
ETS32-422FA2 /516-313 515	3	3,4,5,6	"	"	"	HI	"	ワイシャツ、ブラウス (PP生地、ジョーゼット)	Dress shirts, blouses (P.P. fabrics, georgette)		
ETS32-430FA2 (FA2A) /516-433 (/516-443) 515	3 5	3,4,5 5,6	"	"	"	EX	"	スラックス、パジャマ	Pants, pajamas		
ETS32-434FA2 /516-333 515	3 5	3,4,5 5,6	"	"	"	HI	"	ワイシャツ、ブラウス (PP生地、ジョーゼット、シルク)	Dress shirts, blouses (P.P. fabrics, georgette)		



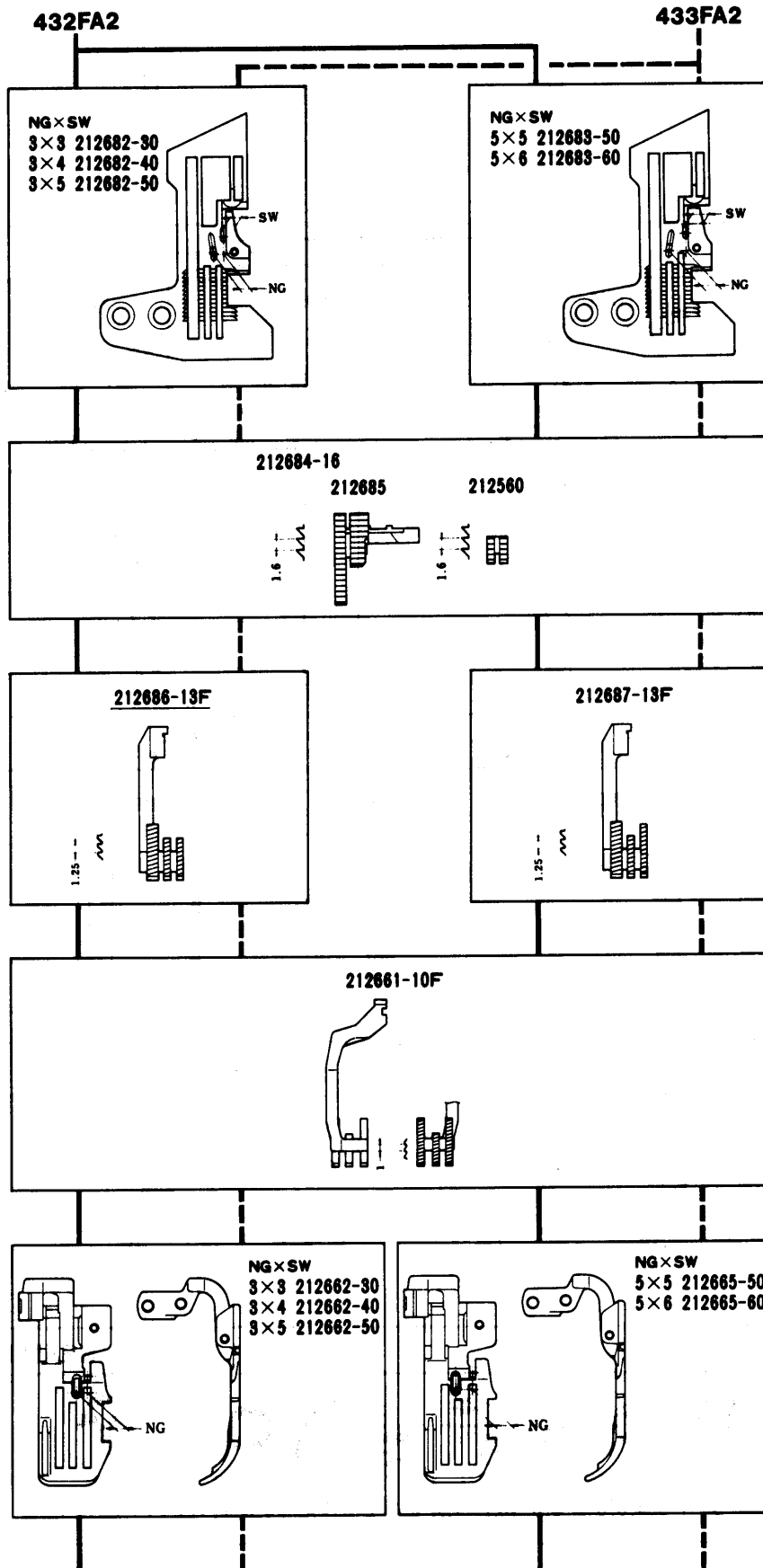

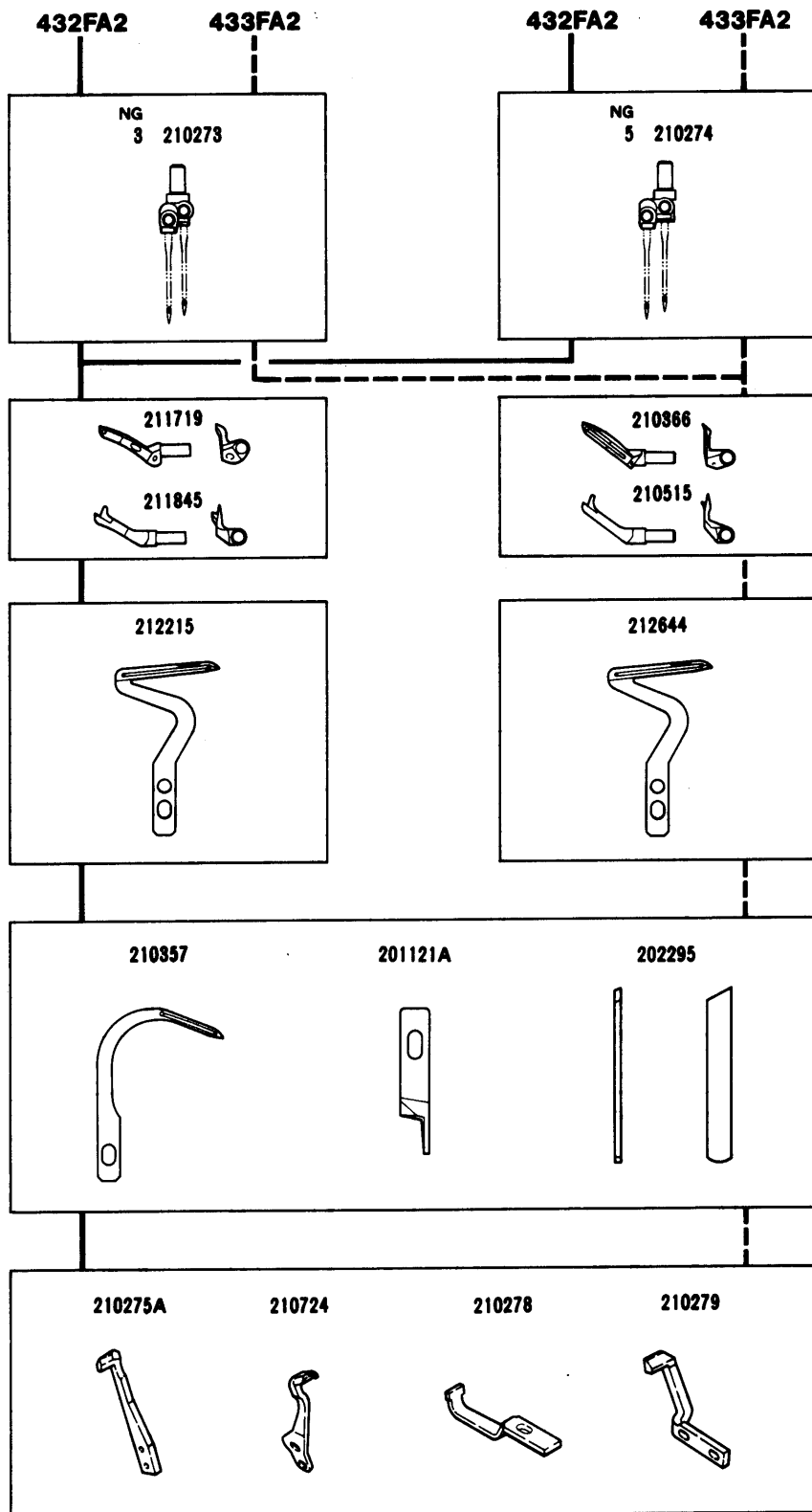





ETS32-432FA2/516-453 ETS32-433FA2/516-353





地縫(薄物~中厚物用)

SEAMING (Light to medium)

										
ETS32-432FA2 /516-453	3	3,4,5	3.8	0.7~1.5	0.7~2	EX	6,000	"	スラックス、パジャマ	Pants, pajamas
	5	5,6								
ETS32-433FA2 /516-353	3	3,4,5	"	"	"	HI	"	"	ワイシャツ、ブラウス (PP生地、ジョーゼット、シルク)	Dress shirts, blouses (P.P. fabrics, silk)
	5	5,6								

ETS32-432FC2/P1(P2)/516-453

ETS32-433FC2/P1(P2)/516-333

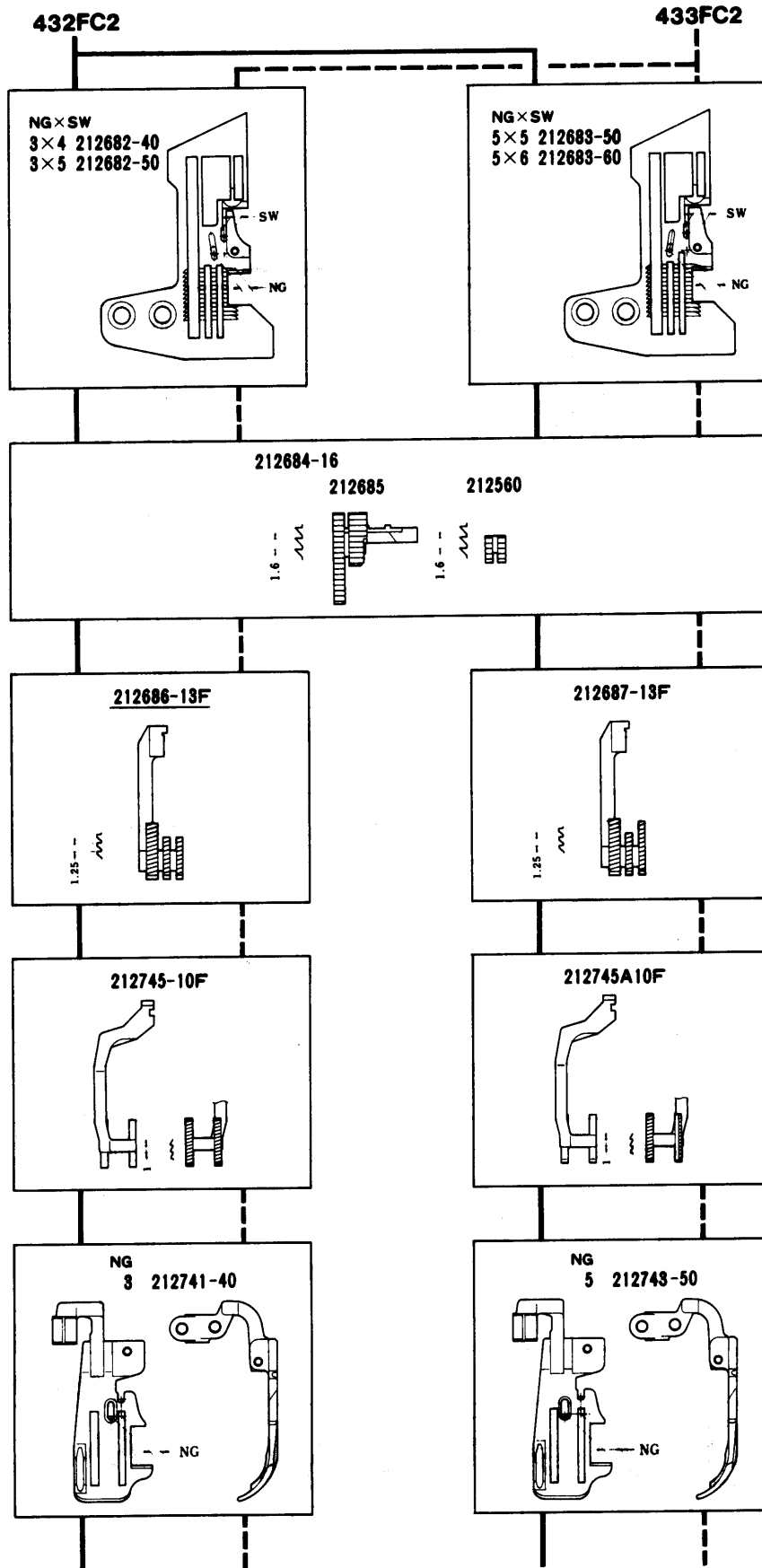

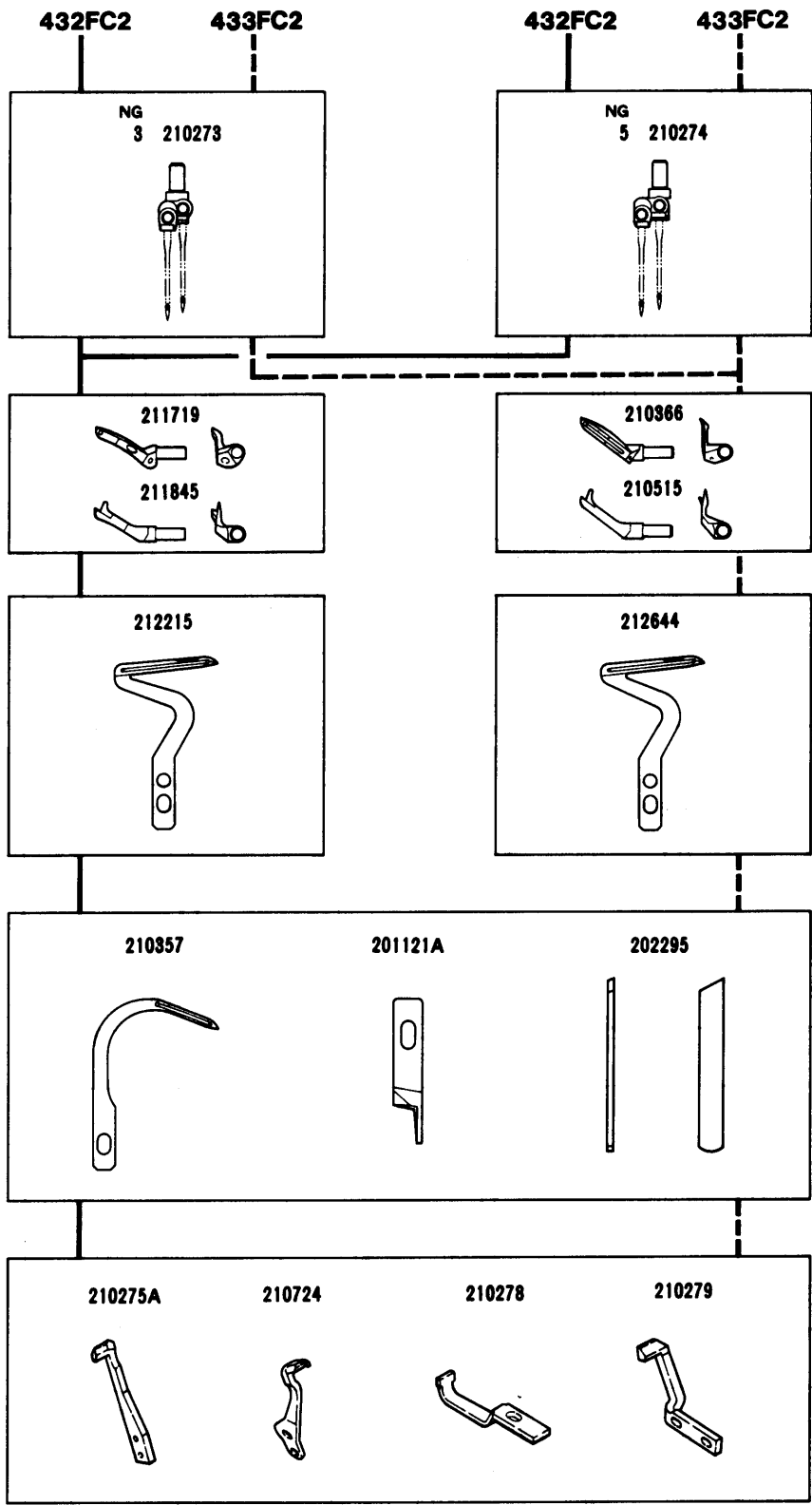

パイピング

PIPING

ETS32-432FC2/P1(P2) /516-453 /515-453	3	4,5	3.8	0.7~1.5	0.7~2	EX	6,000	トレーニングウェア	Sportswear
	5	5,6							
ETS32-433FC2/P1(P2) /516-333 /515-333	3	4,5	"	"	"	HI	"	薄物のジーンズ トレーニングウェア	Lightweight jeans, Sportswear
	5	5,6							

ETS32-542FD2/516-453 ETS32-544FD2/516-353

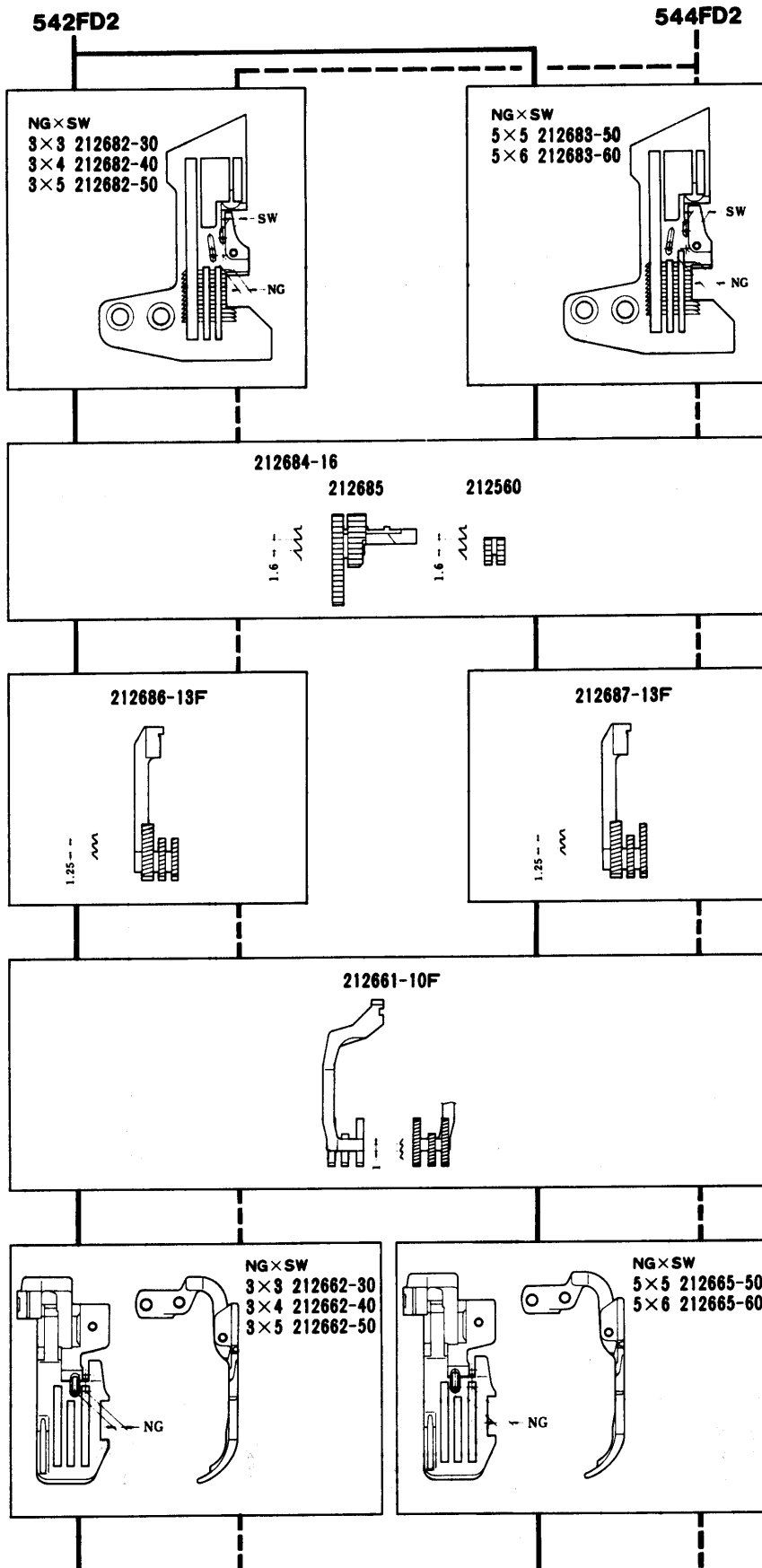

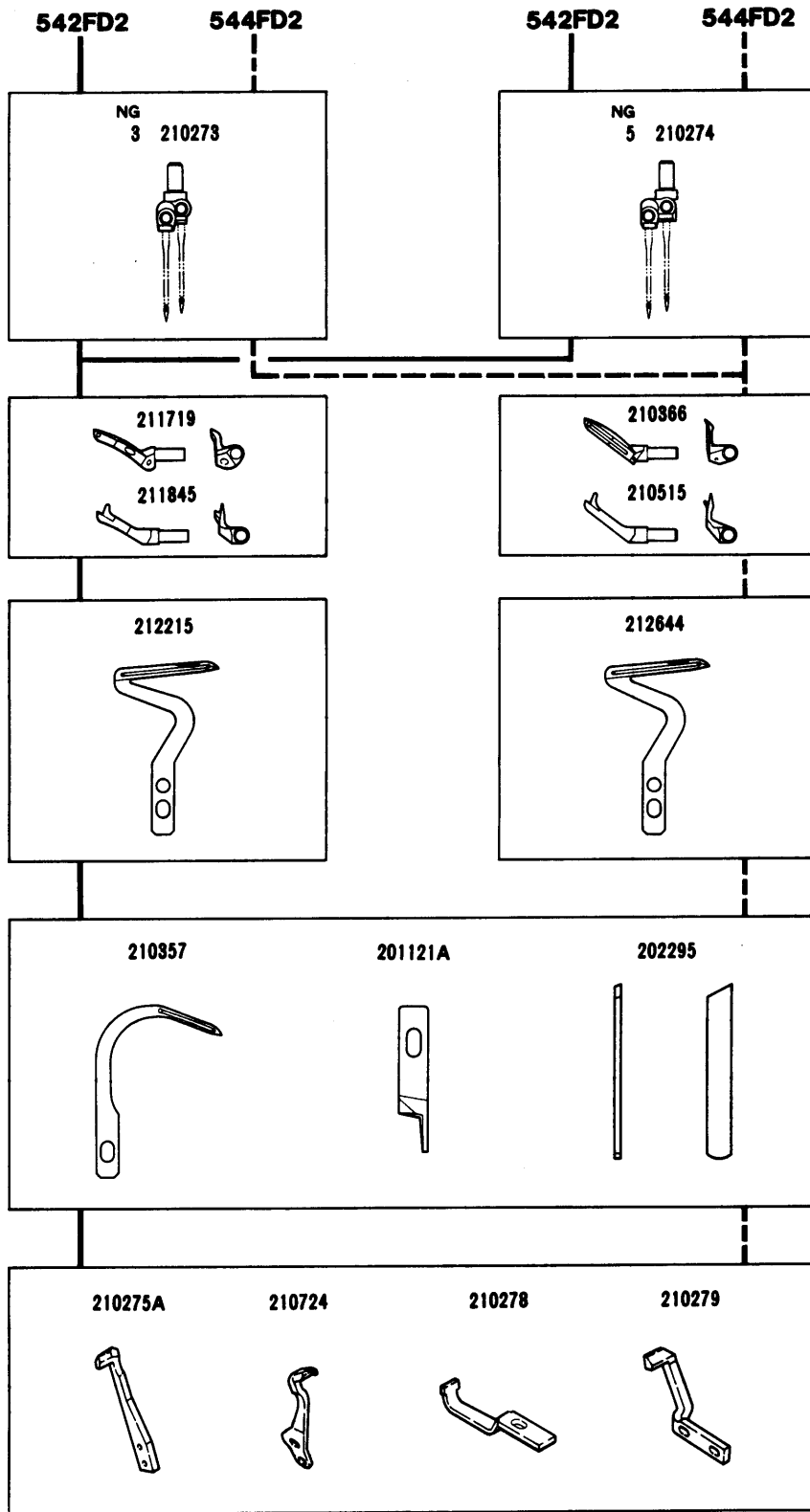

ギャザリング

GATHERING

ETS32-542FD2 /516-453/KL100 515	3	3,4,5	3.8	0.7~1.9	0.7~2	EX	5,500	枕カバー、ふとんカバー	Pillow cases, chair covers	
	5	5,6								
ETS32-544FD2 /516-353/KL100 515	3	3,4,5	"	"	"	HI	"	枕カバー、ふとんカバー	Pillow cases, chair covers	
	5	5,6								

ETS32-420FA3/516-413
ETS32-422FA3/516-313



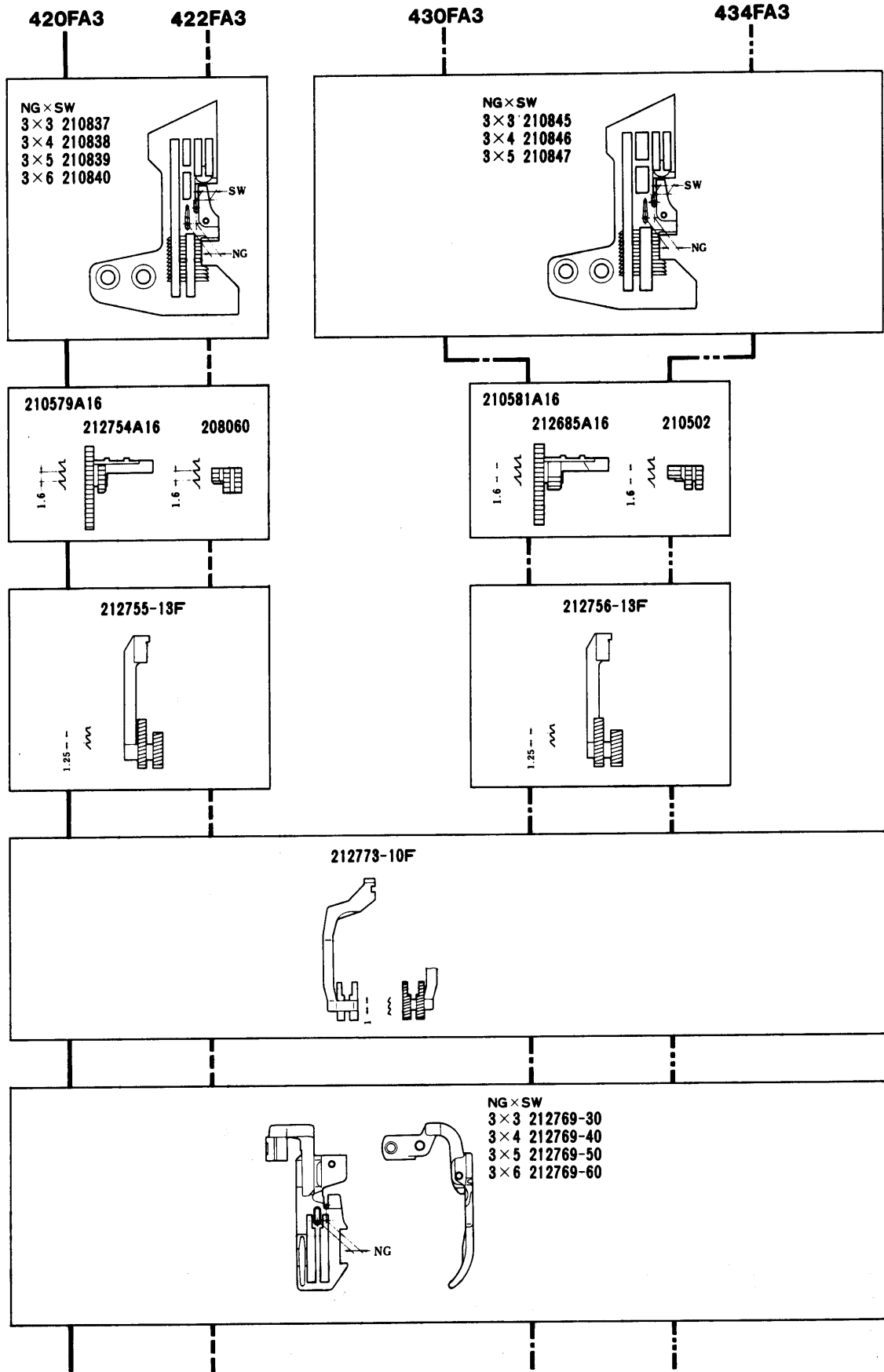

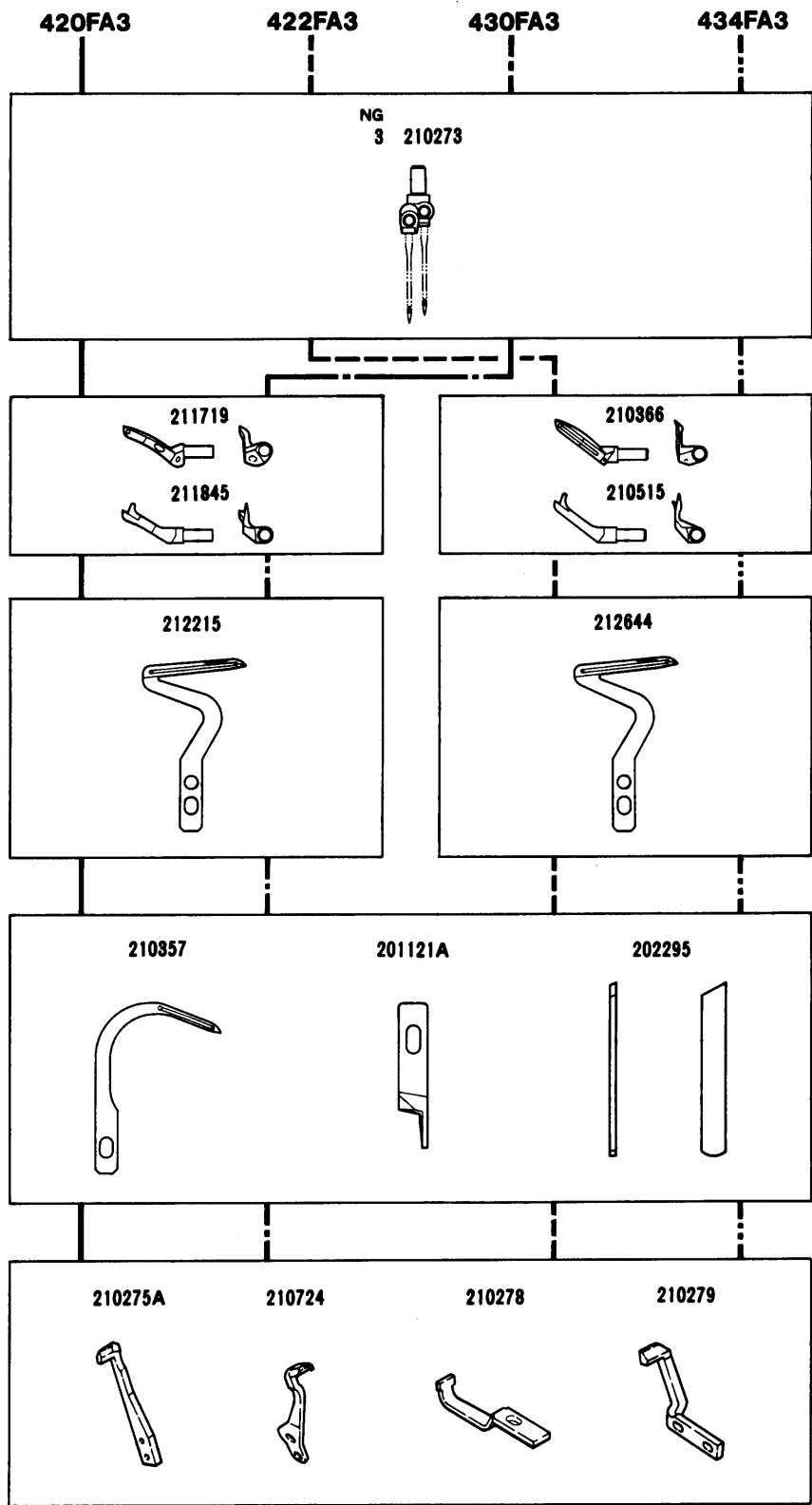





ETS32-430FA3/516-433
ETS32-434FA3/516-333





地縫(薄物~中厚物用)

SEAMING (Light to medium)

									
ETS32-420FA3 /516-413 /515-413	3	3,4,5,6	3.8	0.7~1.5	0.7~2	EX	6,000	スラックス、パジャマ	Pants pajamas
ETS32-422FA3 /516-313 /515-313	3	3,4,5,6	"	"	"	HI	"	ワイシャツ、ブラウス (PP生地、ジョーゼット)	Dress shirts, blouses (P.P. fabrics, georgette)
ETS32-430FA3 /516-433 /515-433	3	3,4,5	"	"	"	EX	"	スラックス、パジャマ	Pants, pajamas
ETS32-434FA3 /516-333 /515-333	3	3,4,5	"	"	"	HI	"	ワイシャツ、ブラウス (PP生地、ジョーゼット、シルク)	Dress shirts, blouses (P.P. fabrics, georgette, silk)

ETS32-432FA3/516-453

ETS32-433FA3/516-353

432FA3



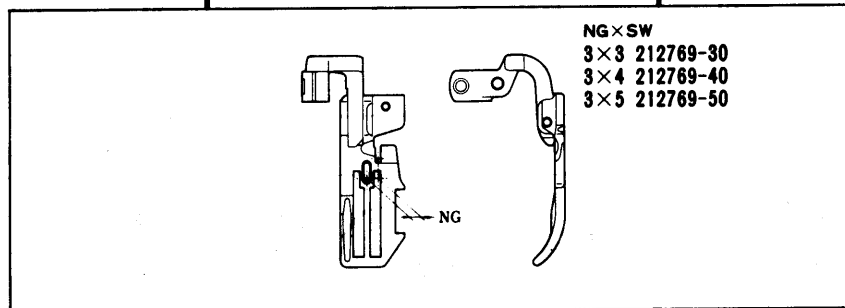
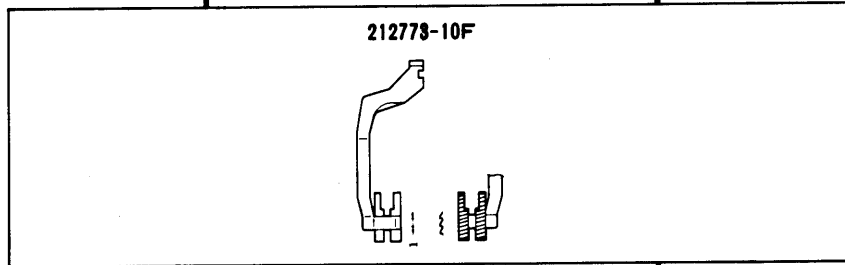
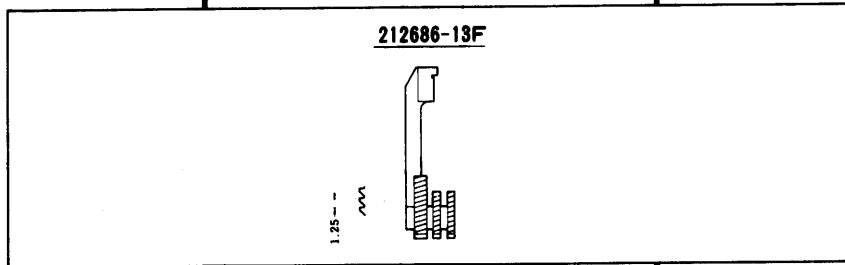
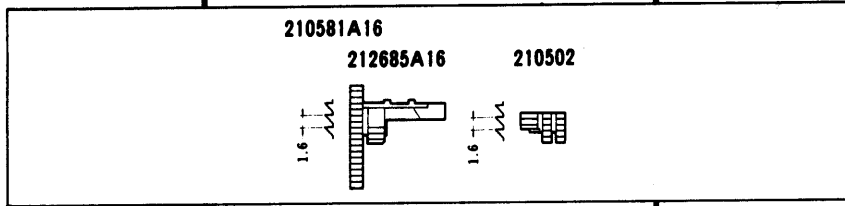
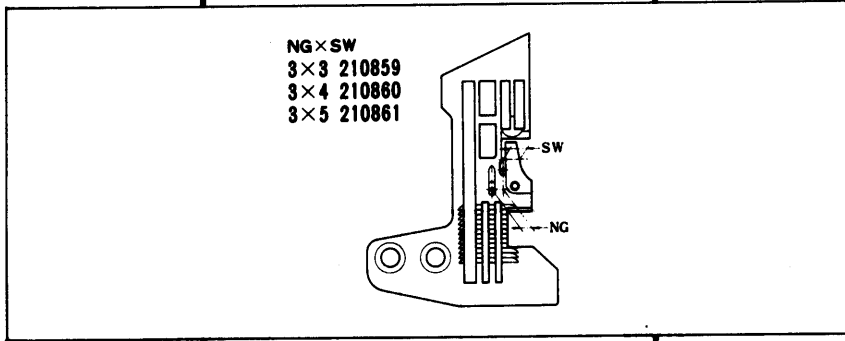

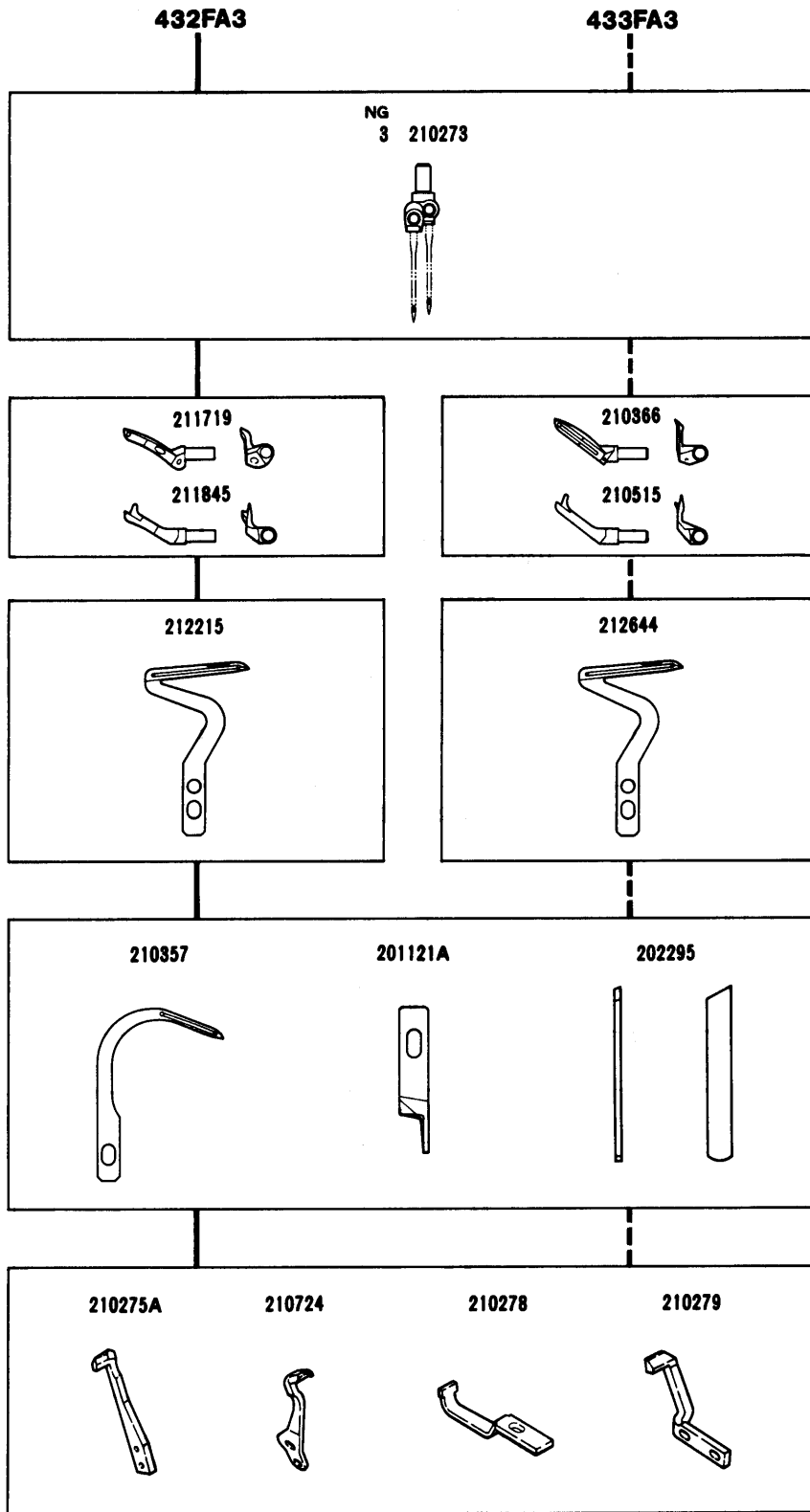





433FA3





地縫(薄物~中厚物用)

SEAMING (Light to medium)

									
ETS32-432FA3 /516-453 515	3	3, 4, 5	3.8	0.7~1.5	0.7~2	EX	6,000	スラックス、パジャマ	Pants, pajamas
ETS32-433FA3 /516-353 515	3	3, 4, 5	"	"	"	HI	"	ワイシャツ、ブラウス (PP生地、ジョーゼット、シルク)	Dress shirts, blouses (P.P. fabrics, georgette, silk)

ETS32-542FD3/516-453 ETS32-544FD3/516-353

542FD3



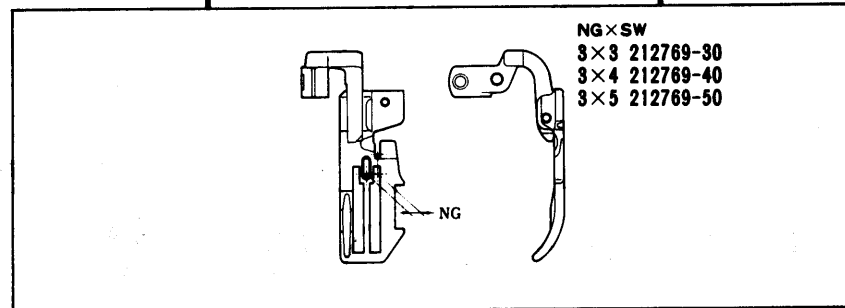
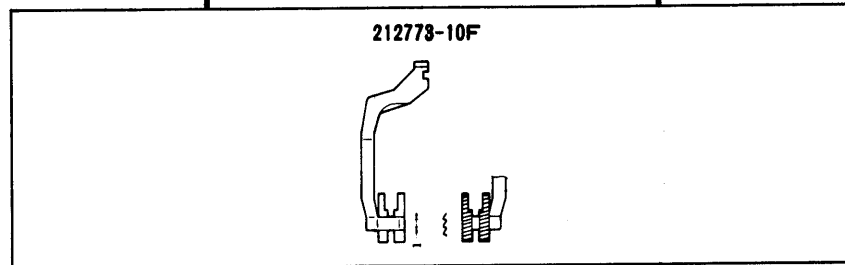
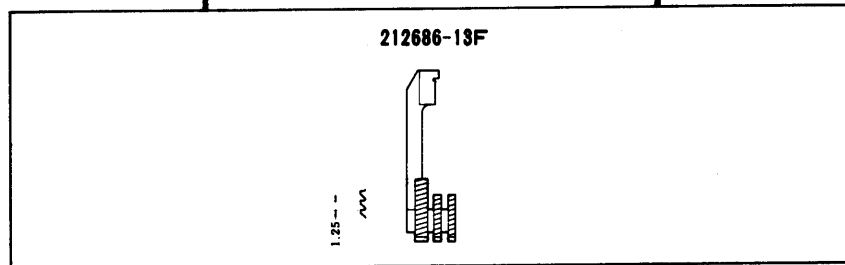
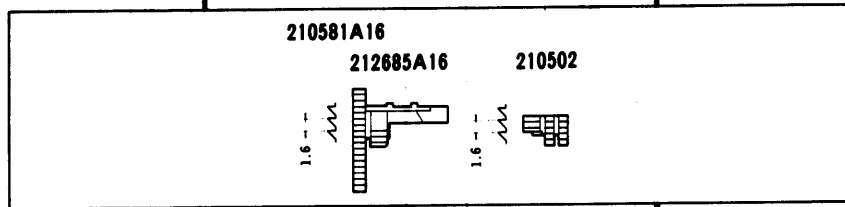
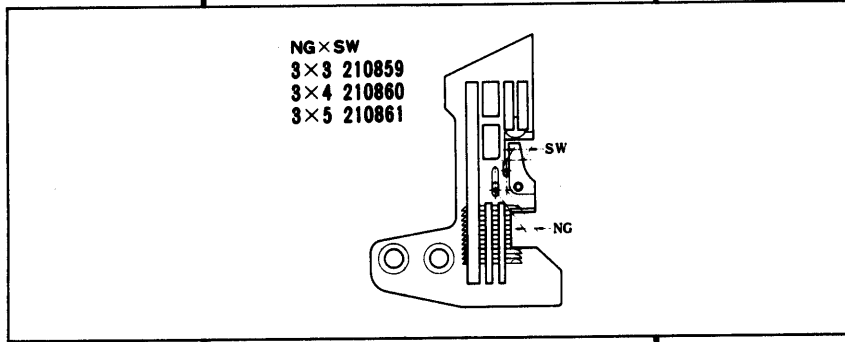

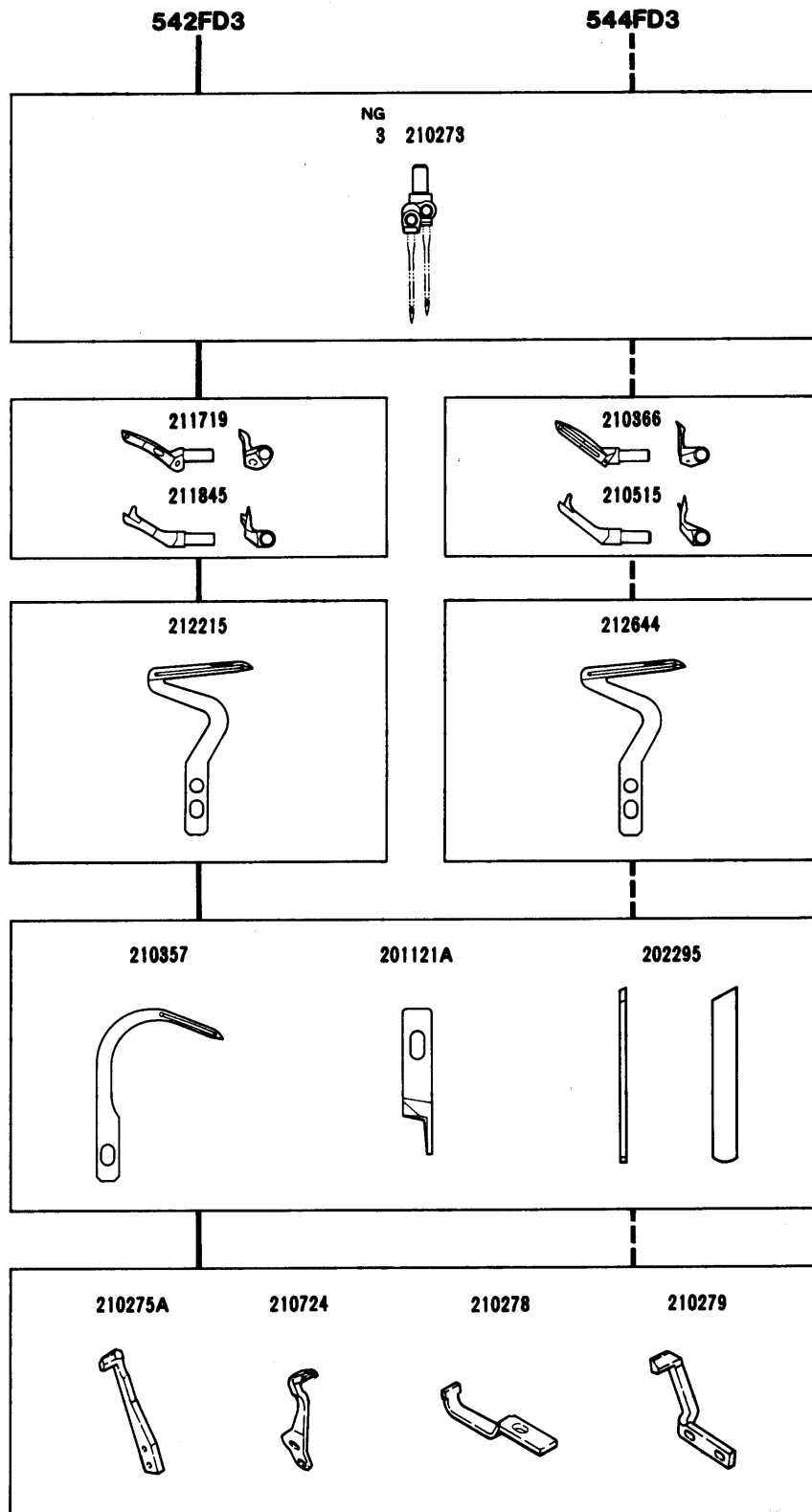





544FD3





ギャザリング

GATHERING

									
ETS32-542FD3 /516-453/KL100 515	3	3, 4, 5	3.8	0.7~1.9	0.7~2	EX	5, 500	枕カバー、ふとんカバー	Pillow cases, chair covers
ETS32-544FD3 /516-353/KL100 515	3	3, 4, 5	"	"	"	H1	"	ブラウス (ジョーゼット、シルク)	Blouses (georgette, silk)

ETS32-430BA2/516-433 ETS32-432BA2/516-453

430BA2

432BA3

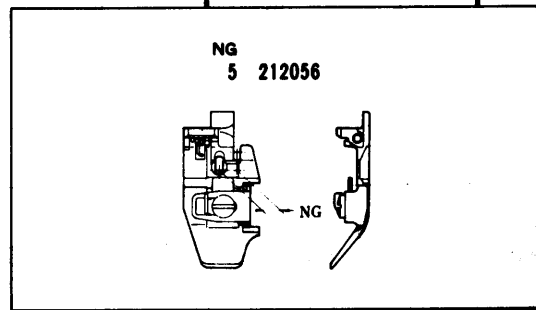
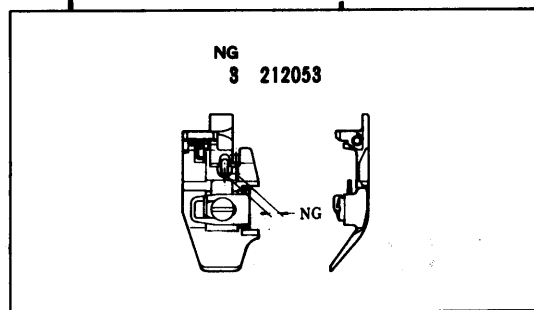
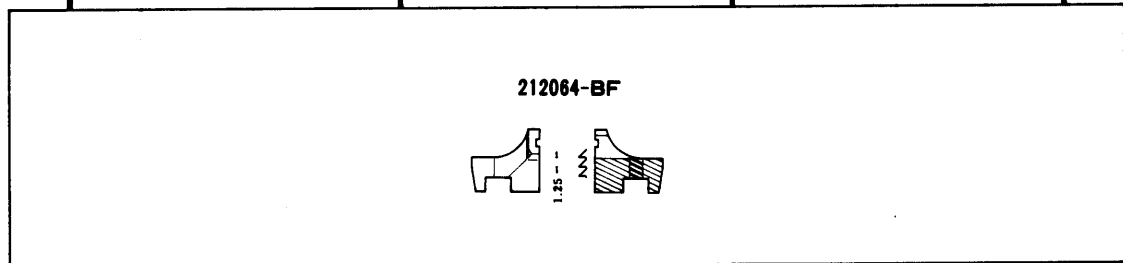
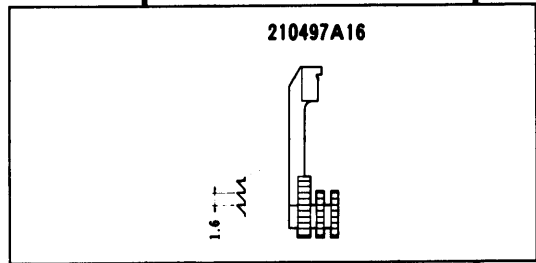
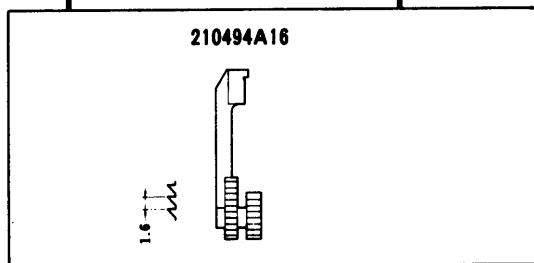
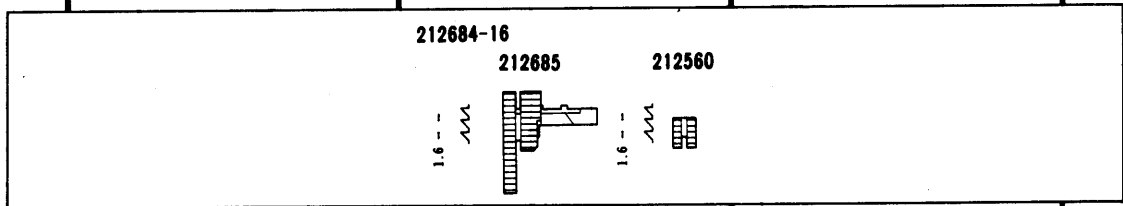
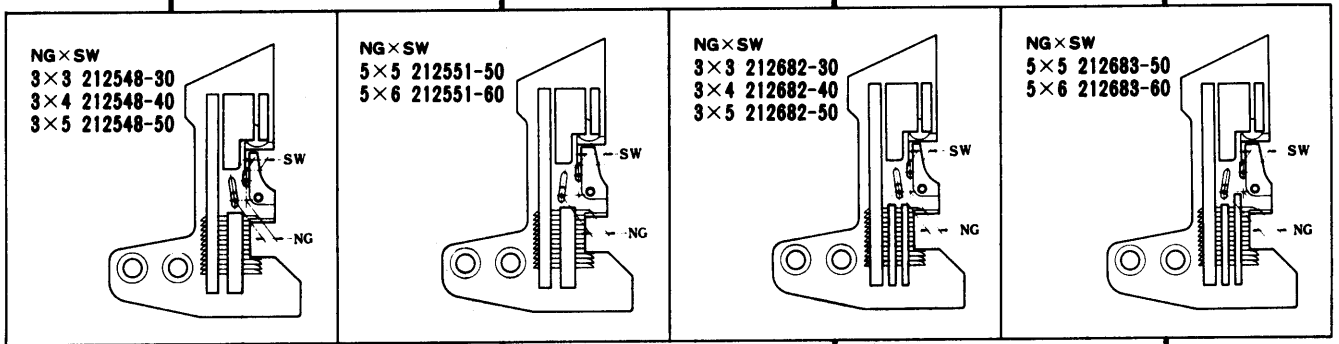

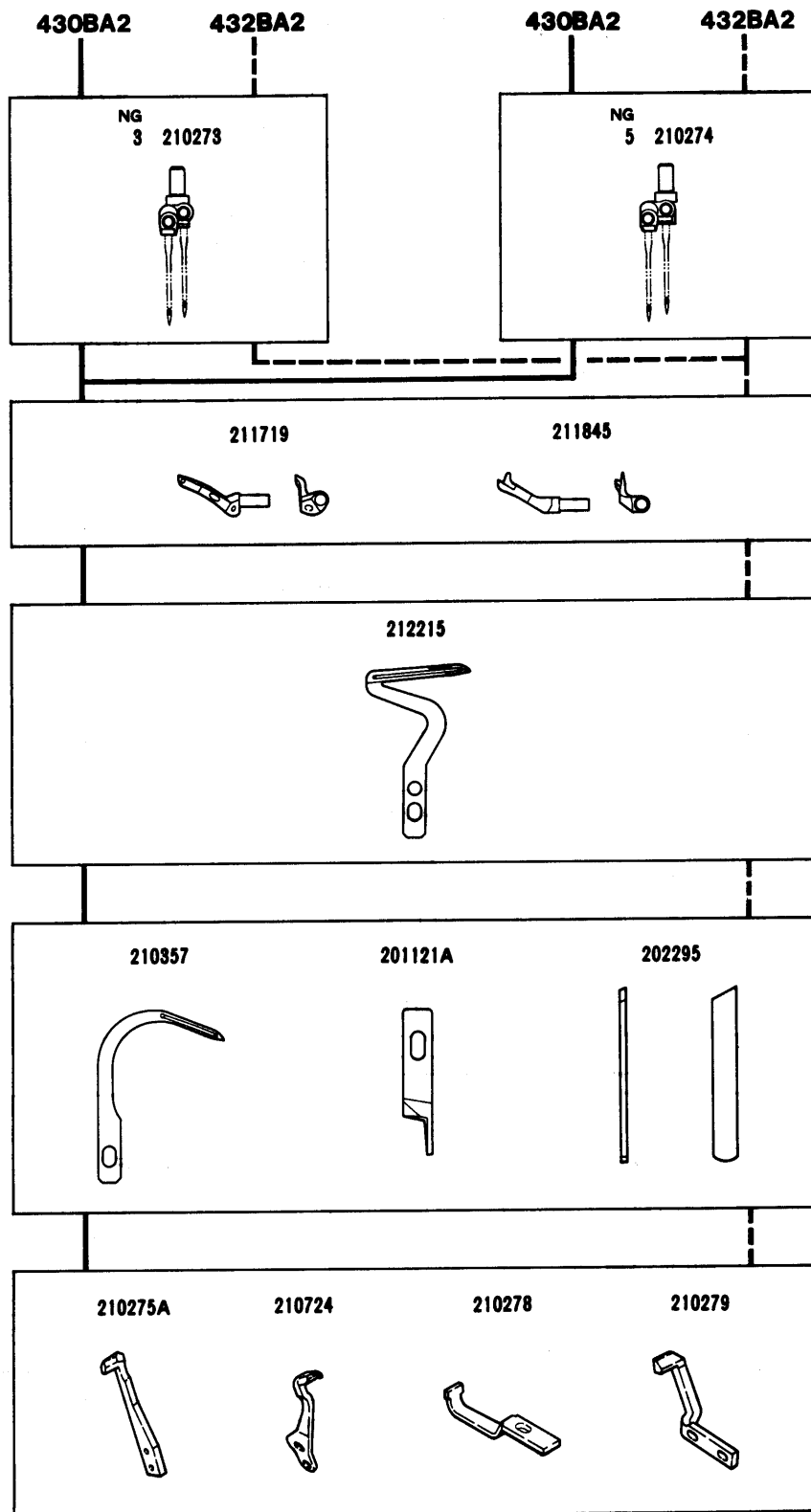

地縫(厚物~極厚物用)

SEAMING (Heavy to extra-heavy)

ETS32-430BA2 /516-433 515-433	3	3, 4, 5	3.8	0.7~1.5	0.7~2	EX	6,000	作業服、綿パン	Working wear, fashion pants	
	5	5, 6								
ETS32-432BA2 /516-453 515-453	3	3, 4, 5	"	"	"	HI	"	作業服、綿パン	Working wear, fashion pants	
	5	5, 6								



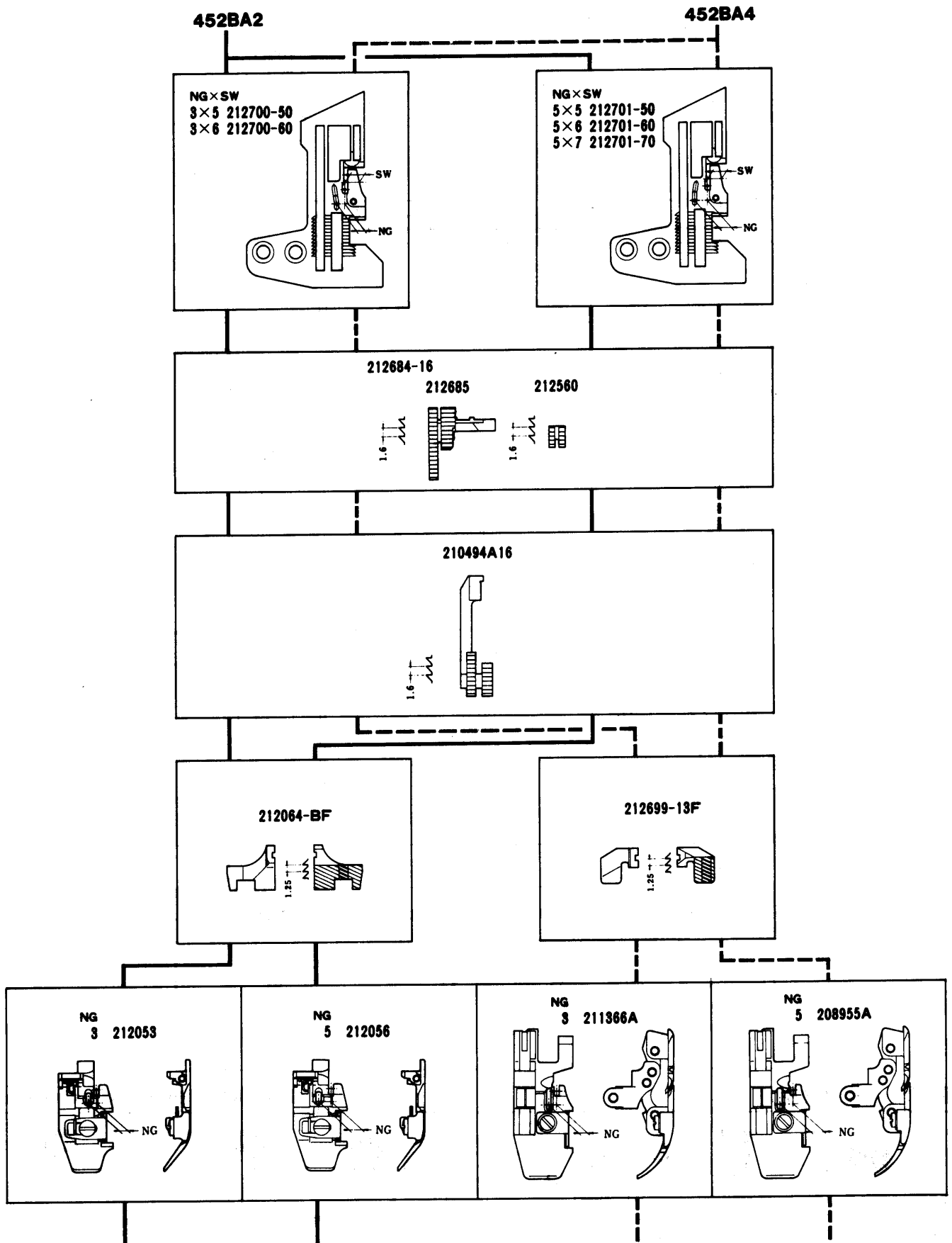

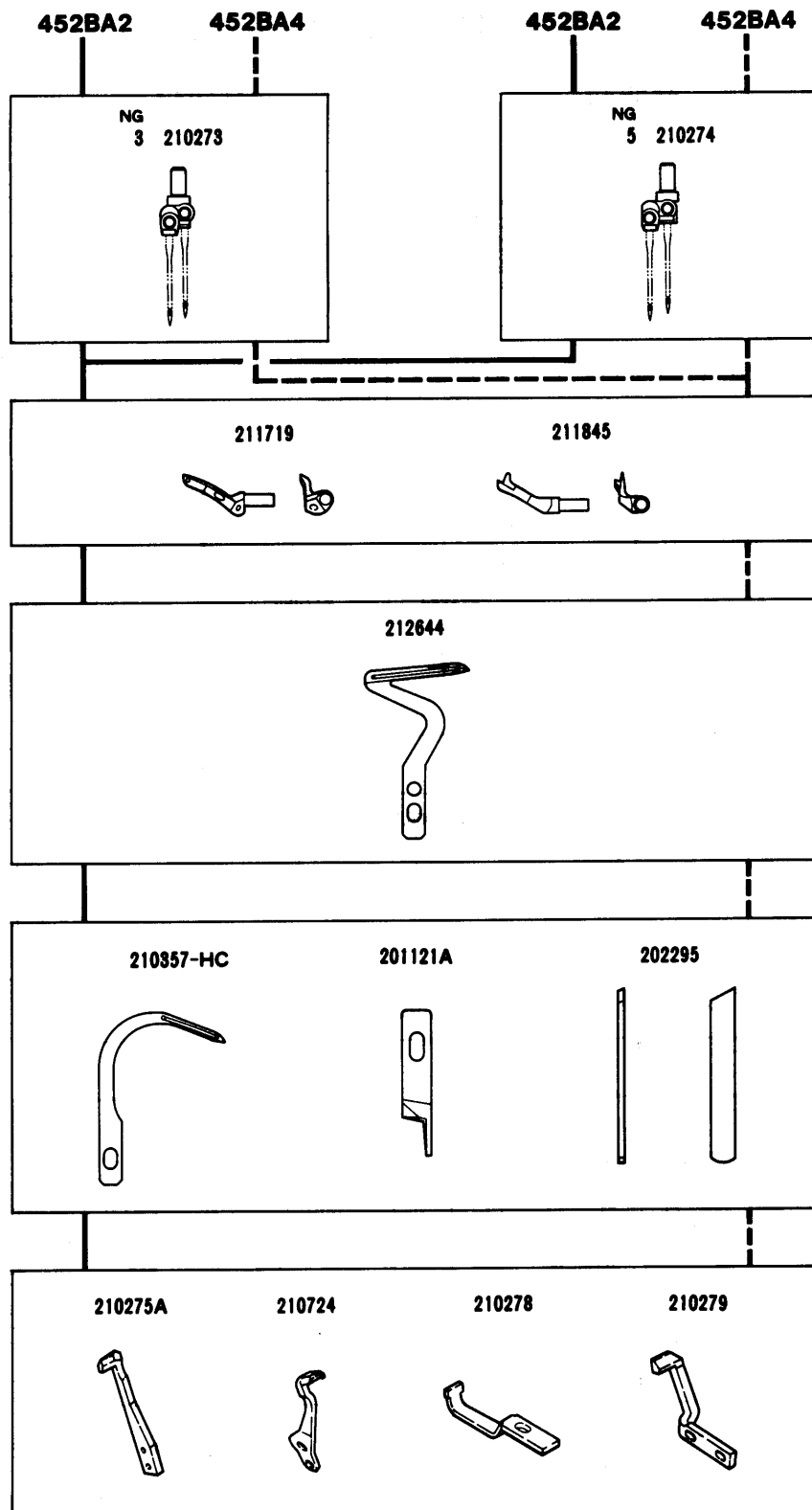





ETS32-452BA2/516-433 ETS32-452BA4/516-433





地縫(厚物~極厚物用)

SEAMING (Light to medium)

										
ETS32-452BA2 /516-433 515-433	3	5,6	3.8	0.7~1.5	0.7~2	EX	5,500	作業服、ジーンズ	Working wear, jeans	
	5	5,6,7								
ETS32-452BA4 /516-433 515-433	3	5,6	"	"	"	"	"	作業服、ジーンズ (トラクター押エ付)	Working wear, jeans (Tractor foot)	
	5	5,6,7								

ETS32-453BA2/516-453 ETS32-453BA4/516-453

453BA2



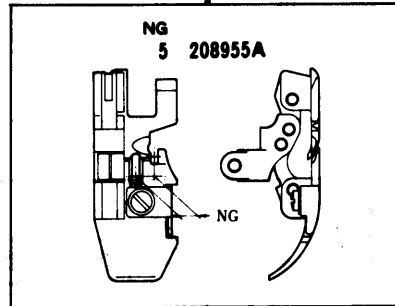
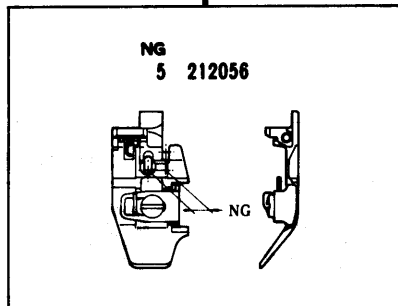
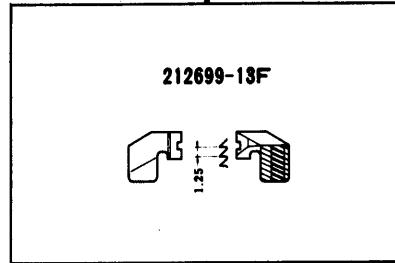
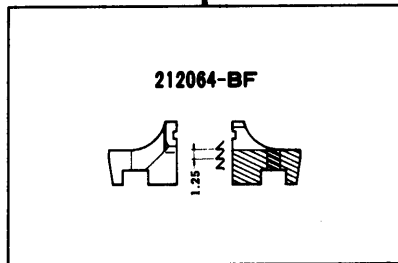
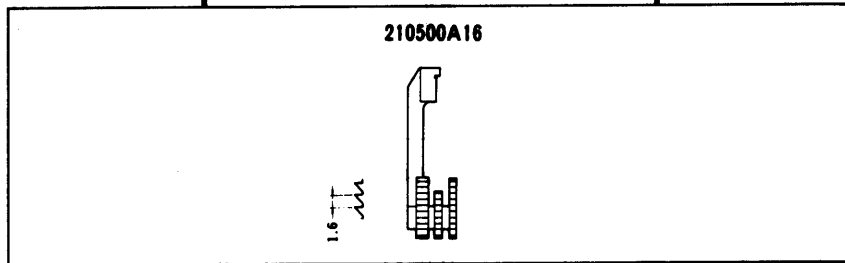
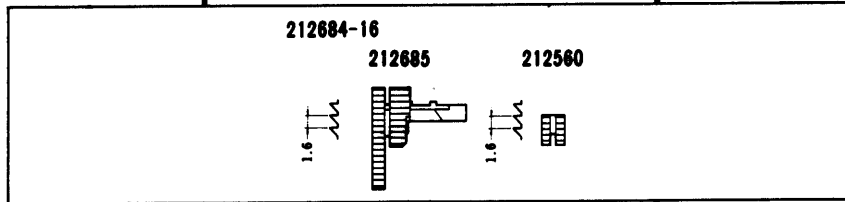
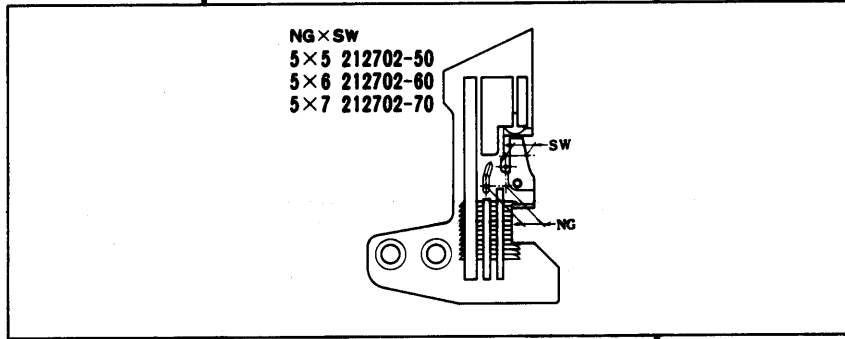

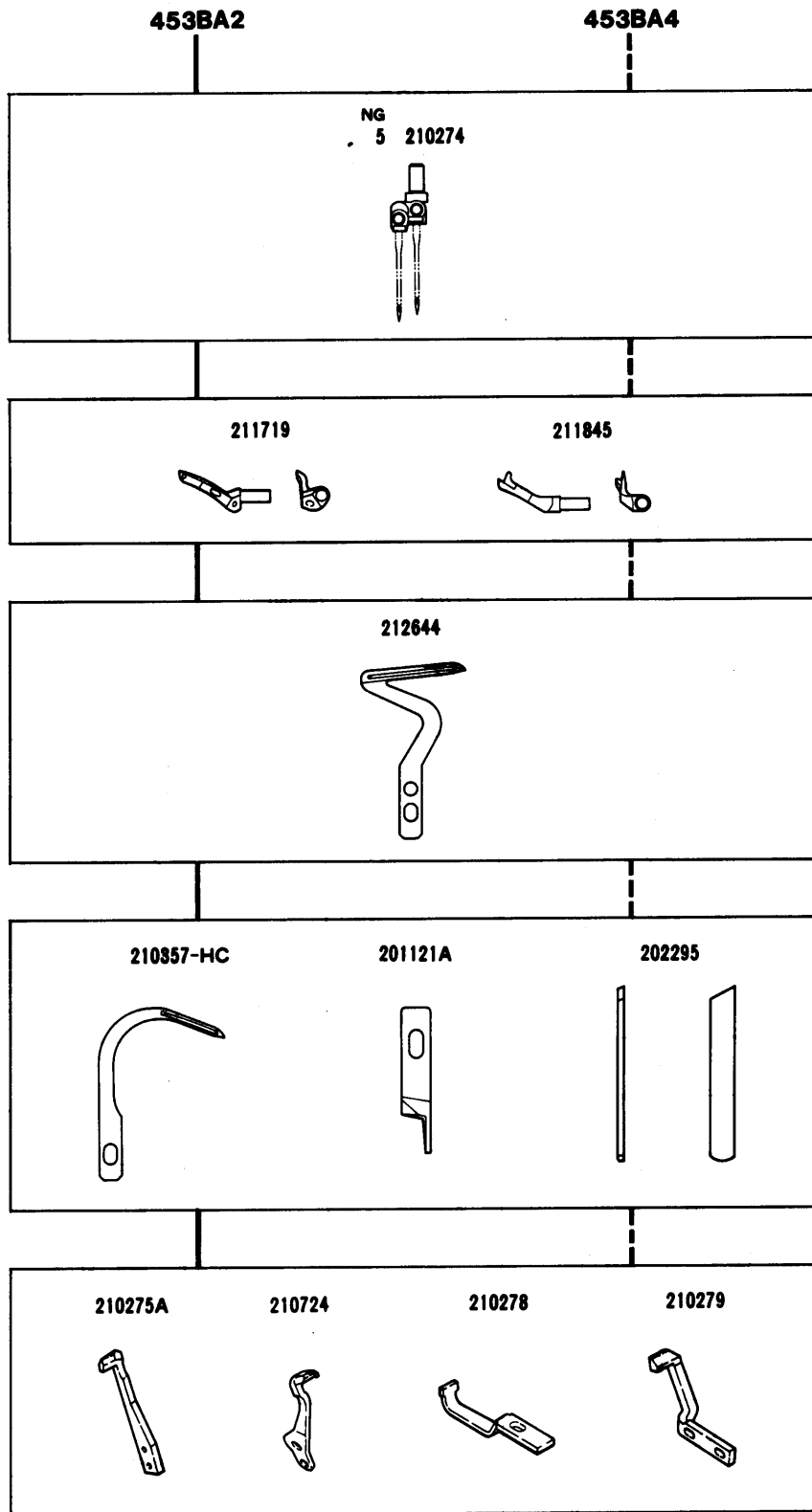





453BA4





地縫(厚物～極厚物用)

SEAMING (Heavy to extra-heavy)

										
ETS32-453BA2 /516-453 515	5	5, 6, 7	3.8	0.7~1.5	0.7~2	EX	5, 500	作業服、ジーンズ	Working wear, jeans	
ETS32-453BA4 /516-453 515	5	5, 6, 7	"	"	"	"	"	作業服、ジーンズ (トラクター押エ付)	Working wear, jeans (Tractor foot)	

ETS32-432BC2/P1(P2)/516-453

432BC2

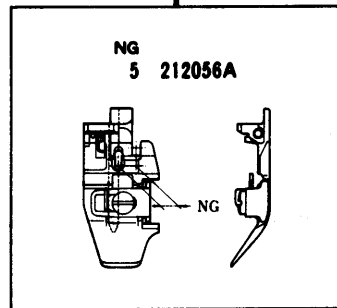
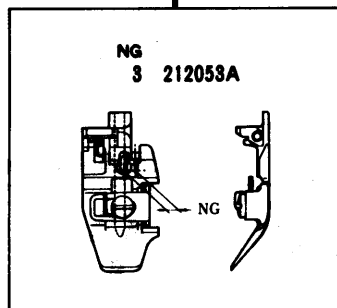
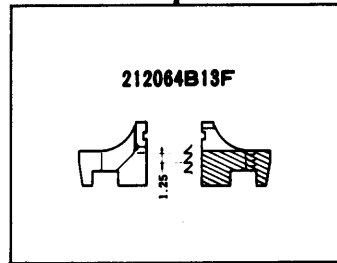
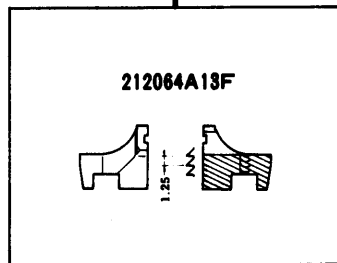
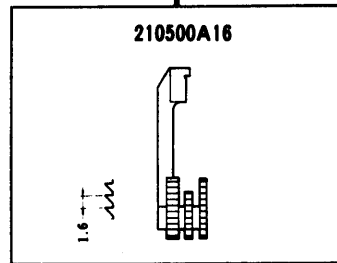
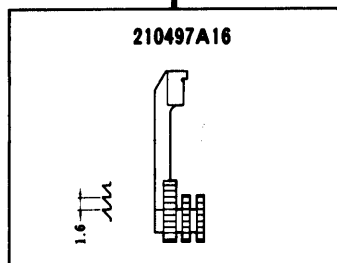
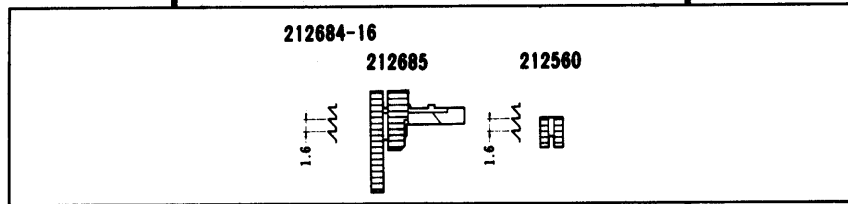
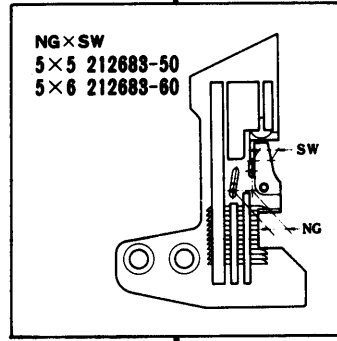
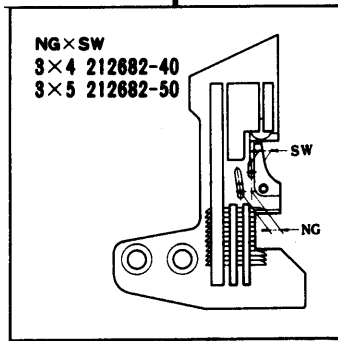

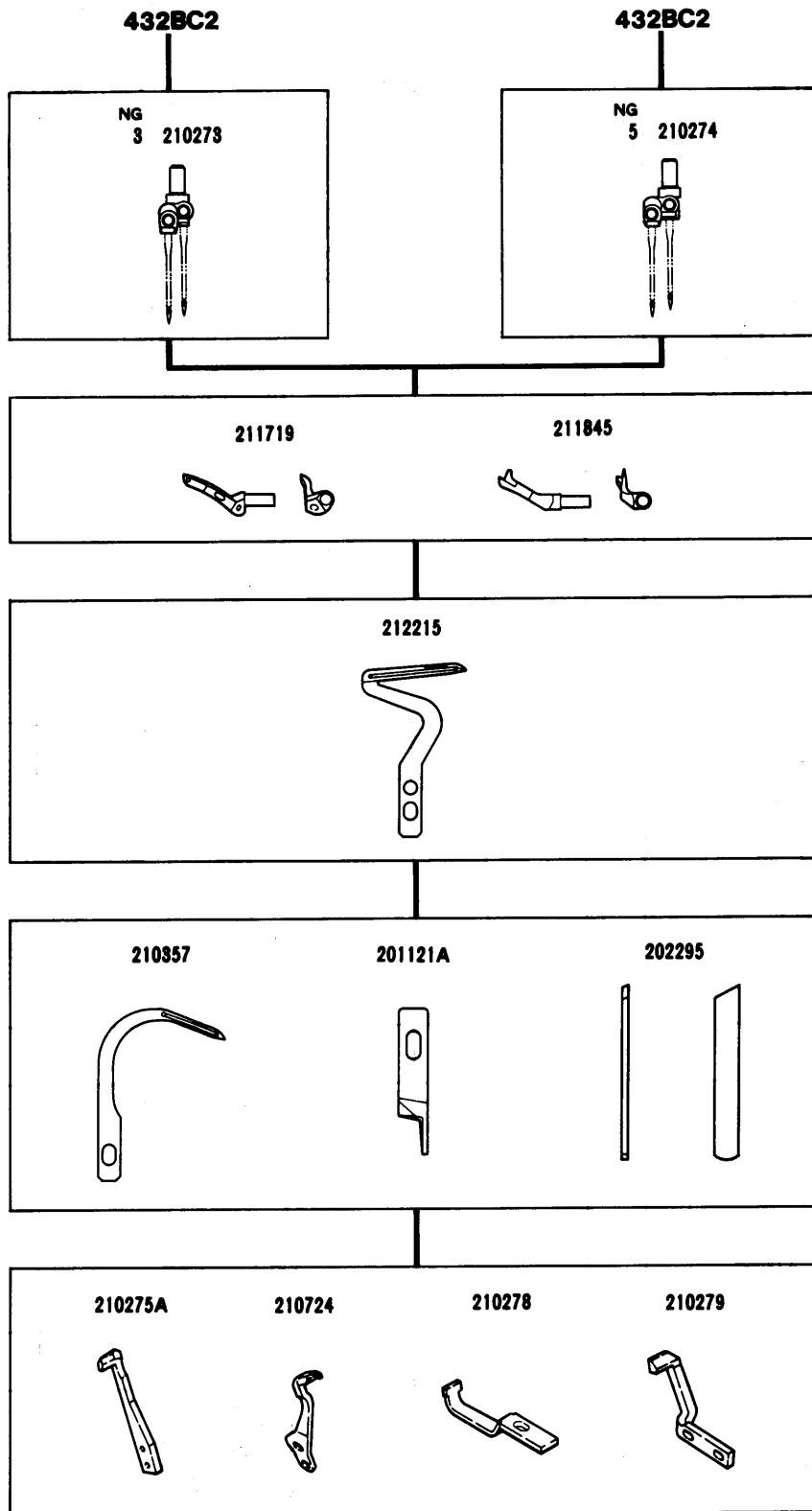

パイピング

PIPING

ETS32-432BC2/P1(P2) /516-453 515	3 5	4,5 5,6	3.8	0.7~1.5	0.7~2	EX	6,000	トレーニングウェア ジーンズ	Sportswear Jeans

ETS32-452FA4/516-455

ETS32-420FA5/516-413
ETS32-422FA5/516-313

452FA4

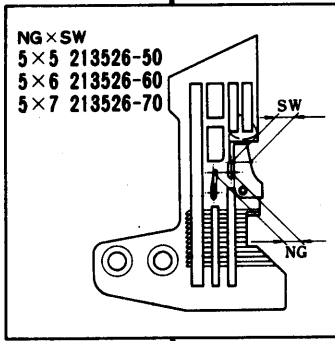

420FA5

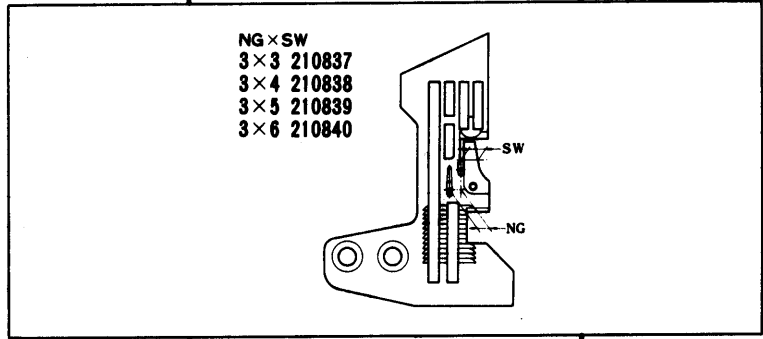



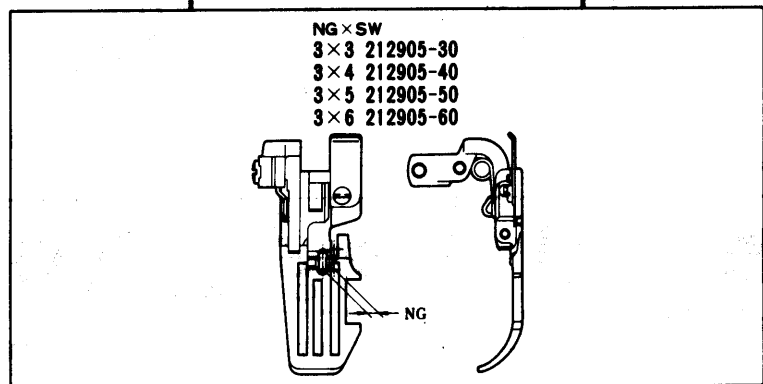
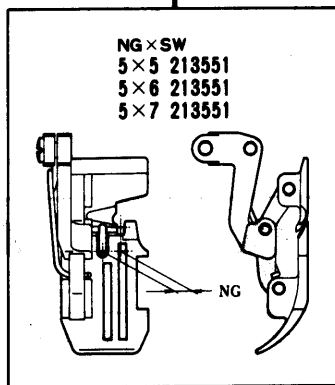
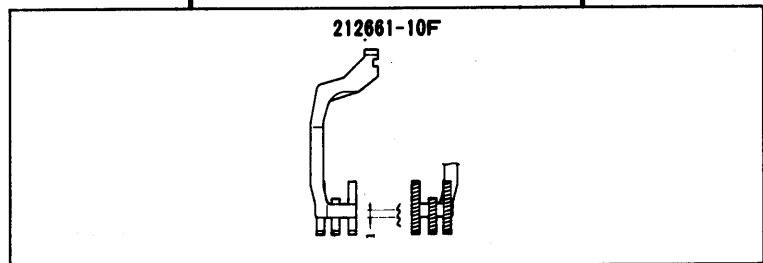
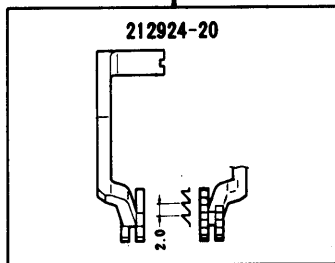
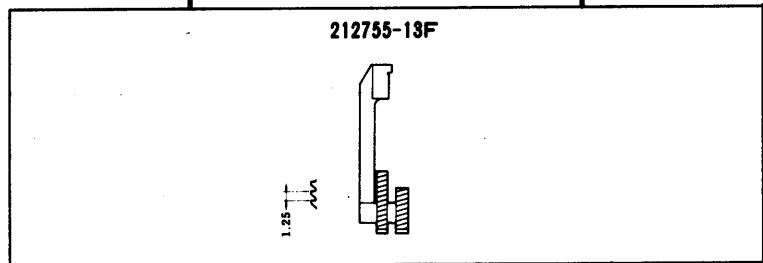
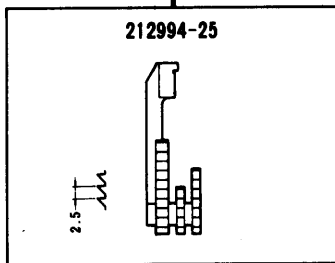
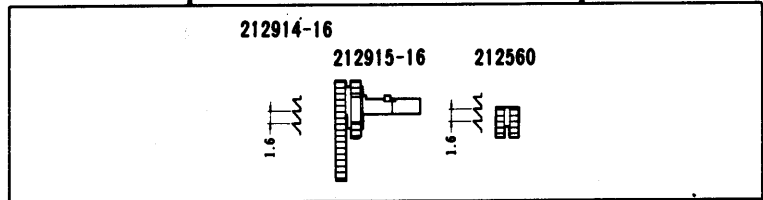
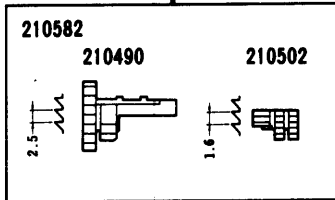

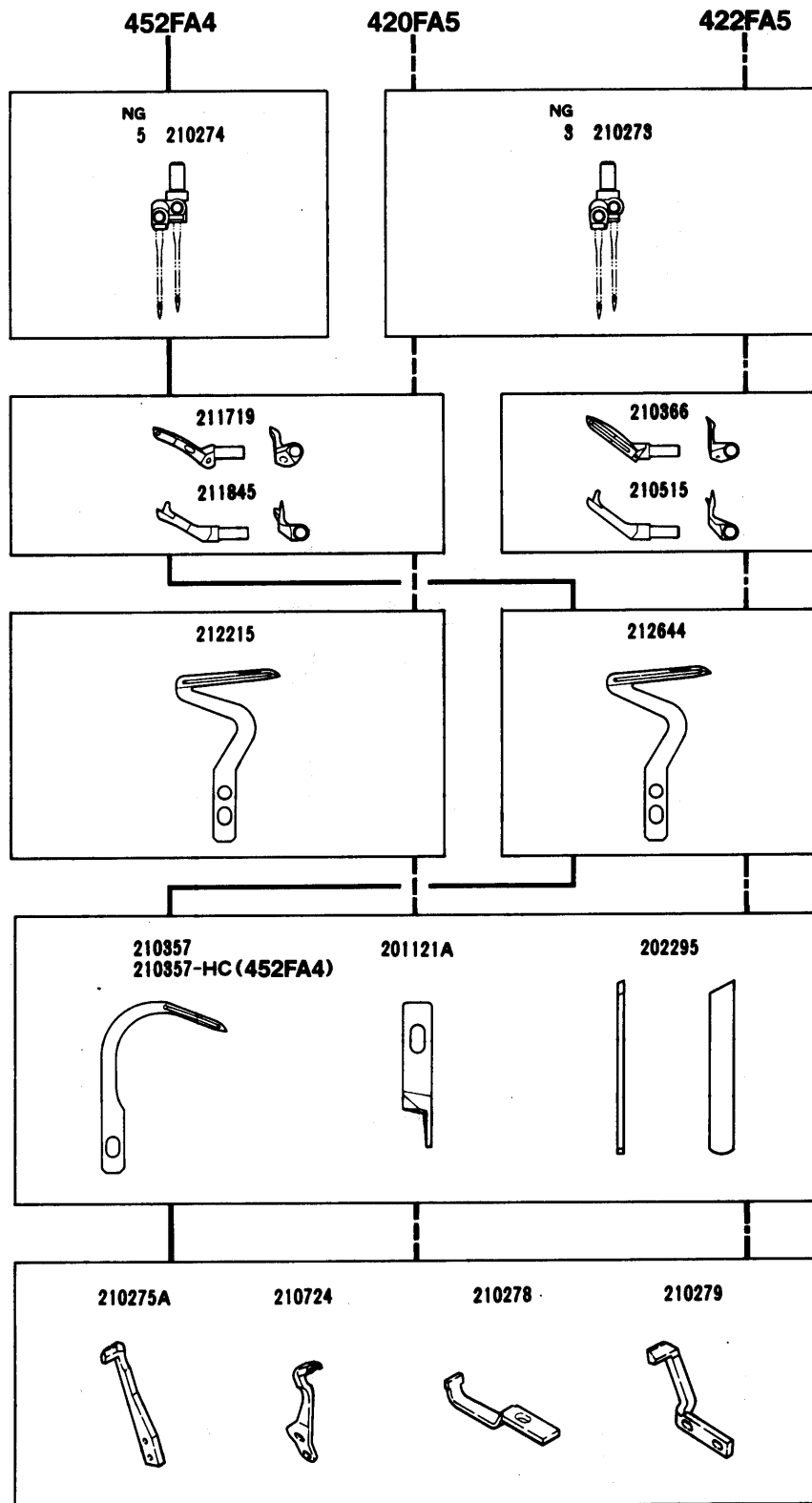





422FA5





地縫(薄物~厚物用)

SEAMING (Light to heavy)



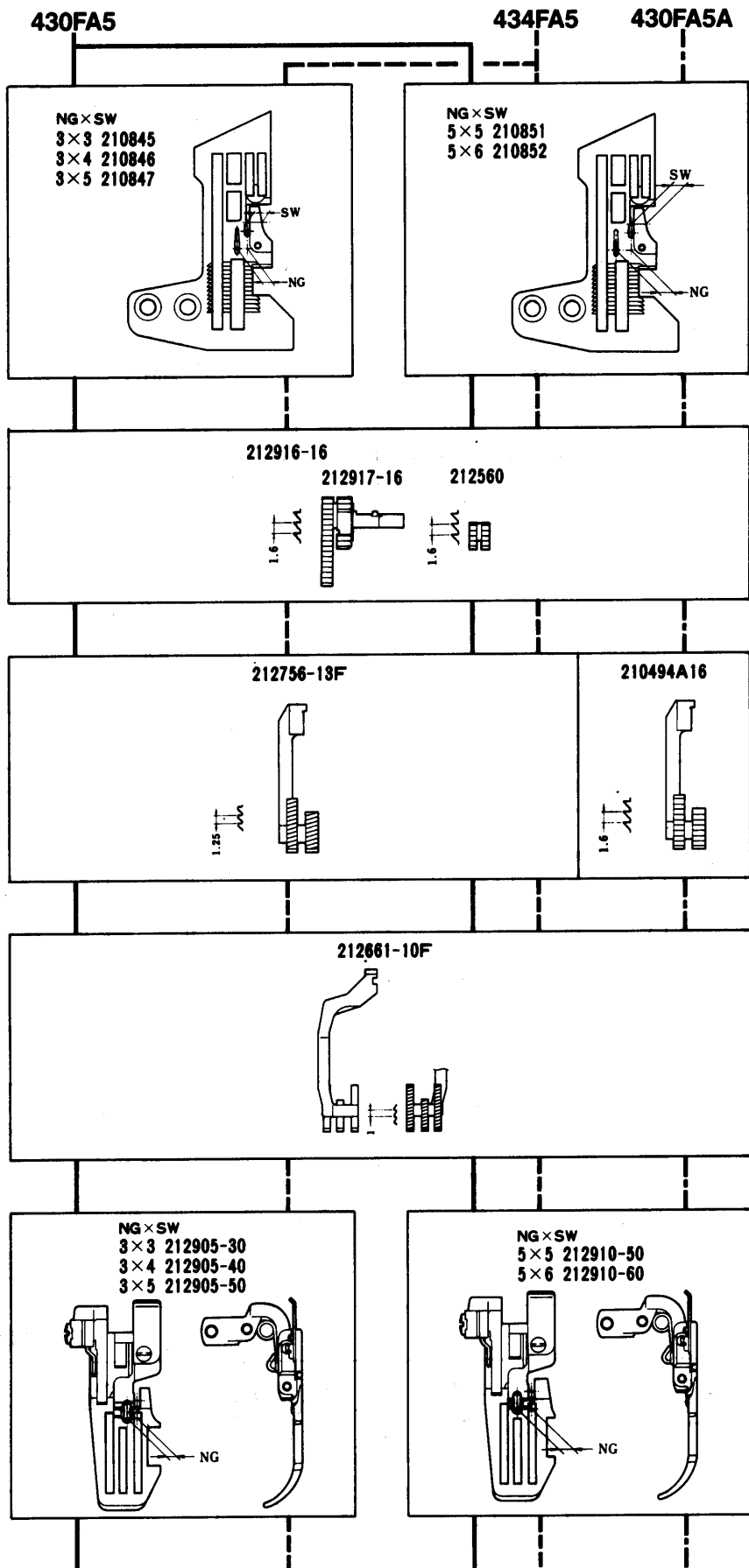

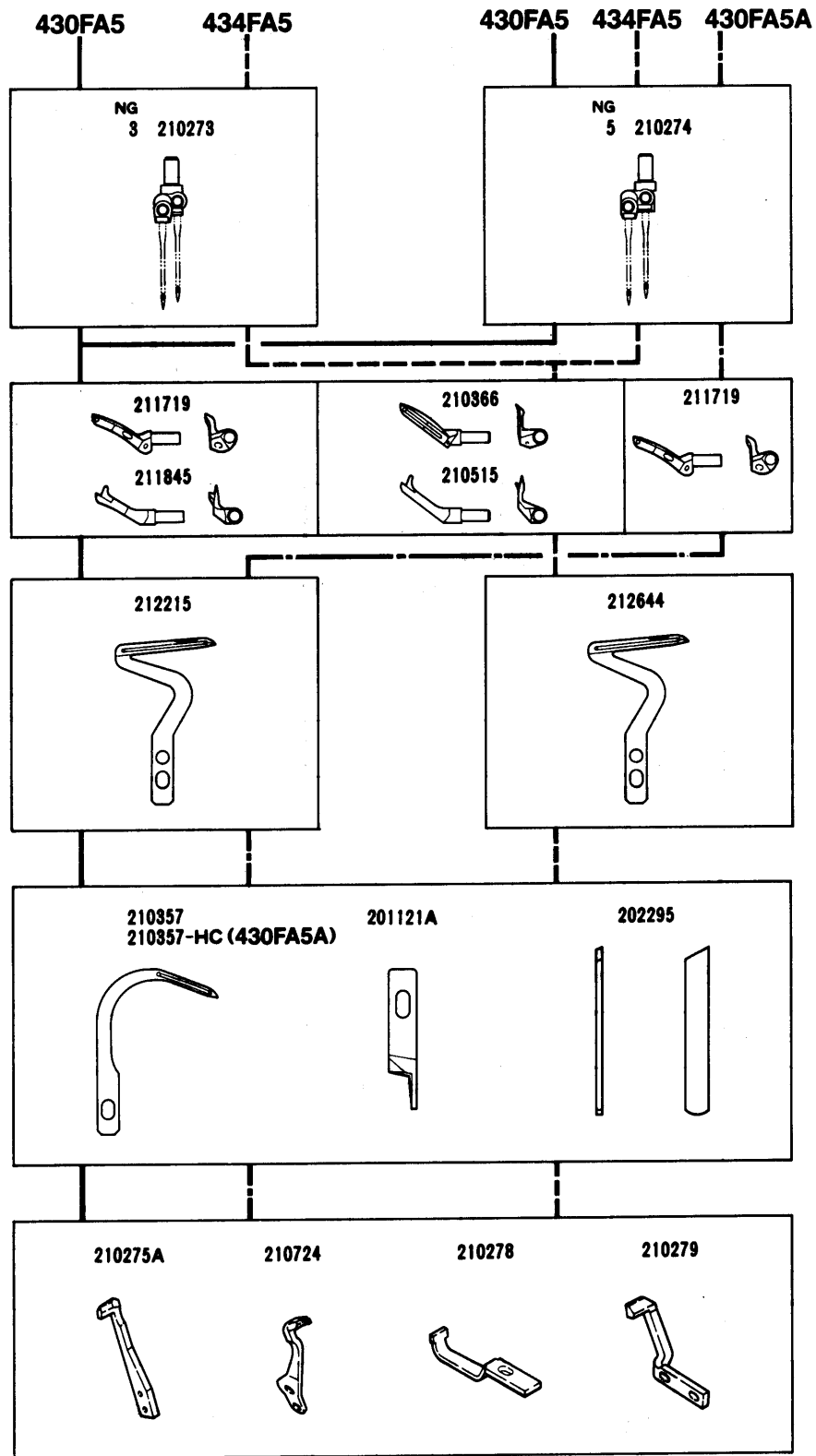





	 mm	 mm	 mm				 s.p.m.		
ETS32-452FA4 /516-455 /515	5	5, 6, 7	3.8	0.7~1.5	0.7~2	EX	5,500	ジーンズ	Jeans
ETS32-420FA5 /516-413 /515	3	3, 4, 5, 6	〃	〃	〃	EX	6,000	スラックス、パジャマ	Pants, pajamas
ETS32-422FA5 /516-313 /515	3	3, 4, 5, 6	〃	〃	〃	HI	〃	ワイシャツ、カジュアルシャツ	Dress shirts, casual wear





地縫 (薄物~中厚物用)

SEAMING (Light to medium)

									
ETS32-430FA5(FA5A) /516-433(/515-433)	3	3,4,5	3.8	0.7~1.5	0.7~2	EX	6,000	薄物のジーンズ 作業服、綿パン	Lightweight jeans, Working wear, fashion pants
	5	5,6							
ETS32-434FA5 /516-333	3	3,4,5	∅	∅	∅	HI	∅	ワイシャツ、ブラウス (PP生地、ジョーゼット、シルク)	Dress shirts, blouses (P.P. fabrics, georgette, silk)
	5	5,6							

ETS32-432FA5/516-453 ETS32-433FA5/516-353

432FA5



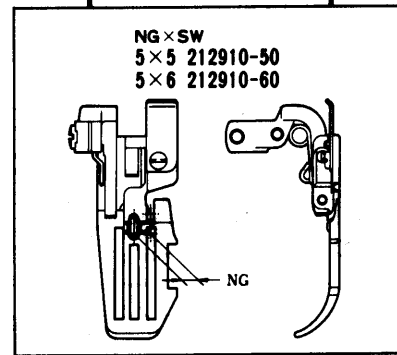
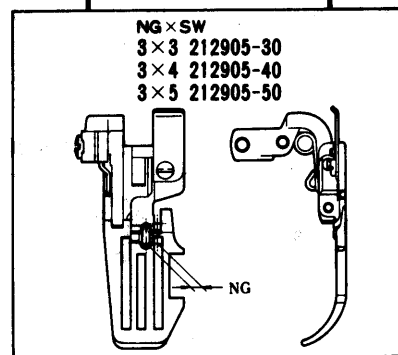
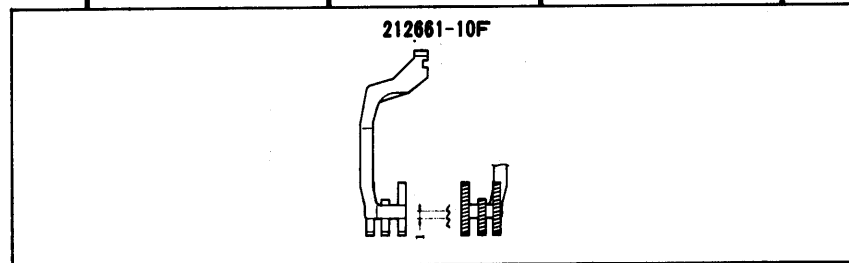
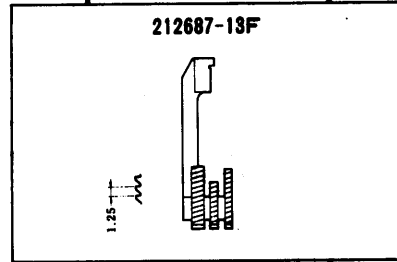
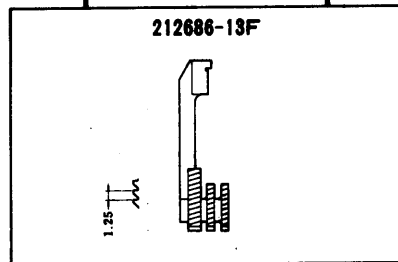
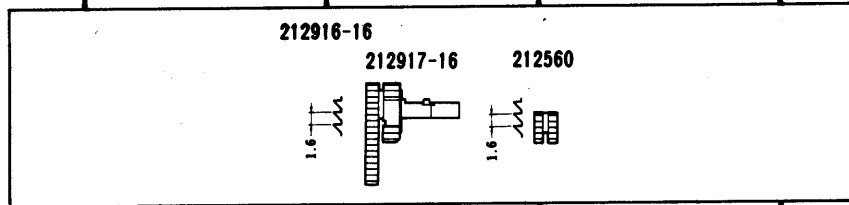
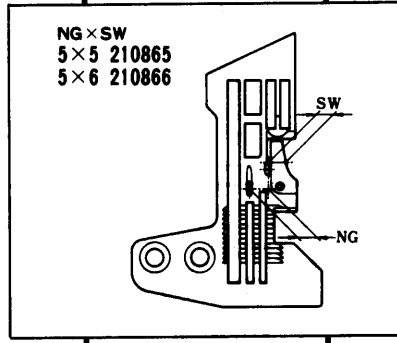
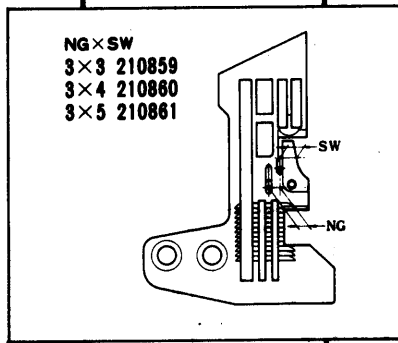

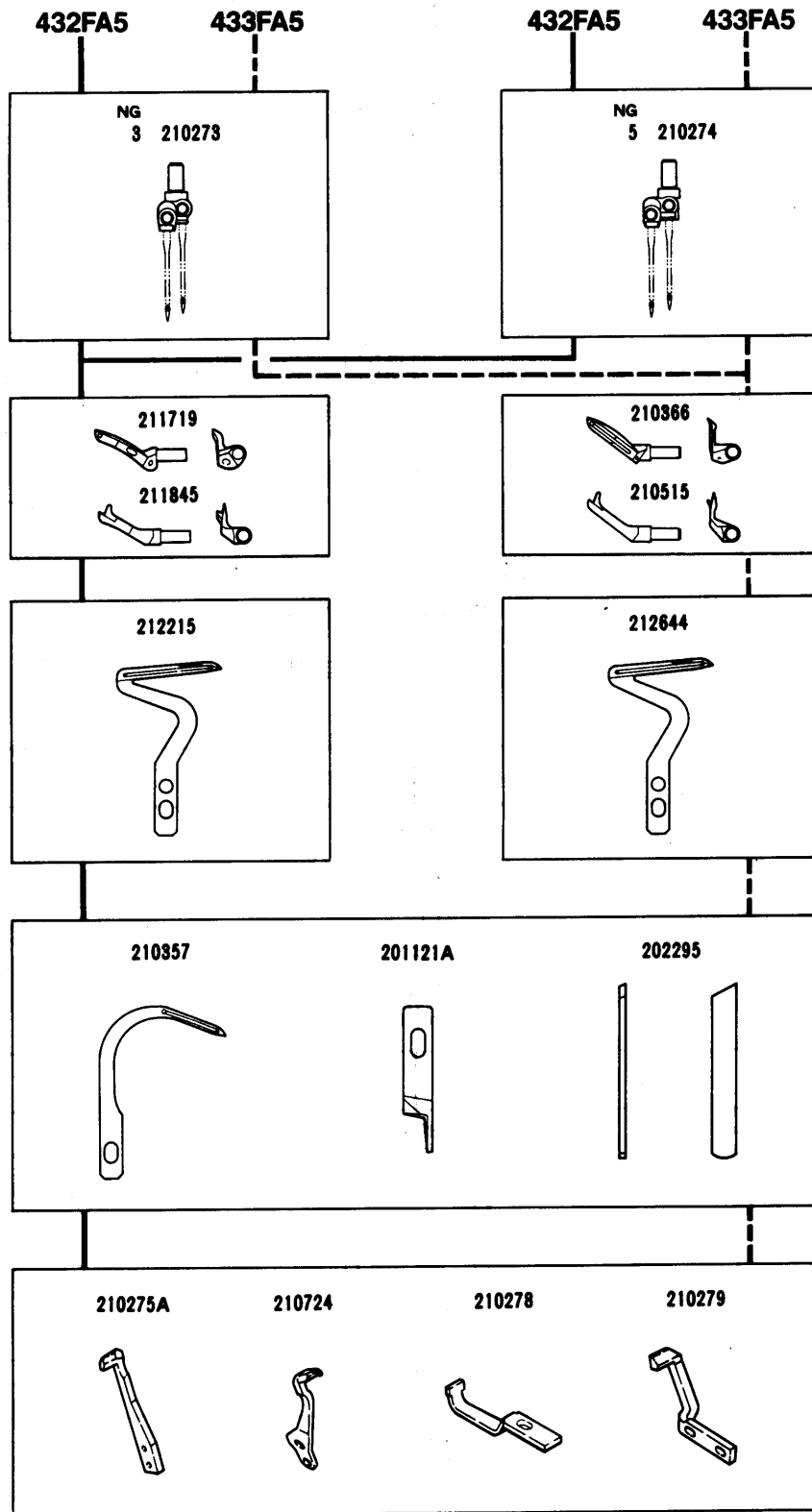





433FA5





地縫(薄物~中厚物用)

SEAMING (Light to medium)

	 mm	 mm	 mm	 mm	 mm		 s.p.m.		
ETS32-432FA5 /516-453 515	3	3,4,5	3.8	0.7~1.5	0.7~2	EX	6,000	スラックス、パジャマ	Pants, pajamas
	5	5,6							
ETS32-433FA5 /516-353 515	3	3,4,5	"	"	"	HI	"	ワイシャツ、ブラウス (PP生地、ジョーゼット、シルク)	Dress shirts, blouses (P.P. fabrics, georgette, silk)
	5	5,6							

ETS32-555AFA4/455

555AFA4

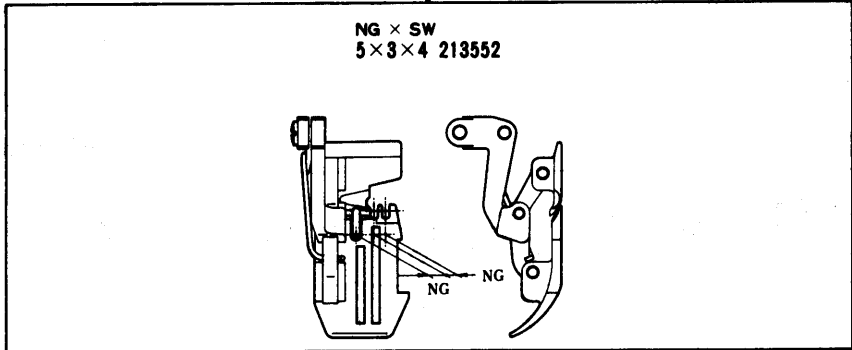
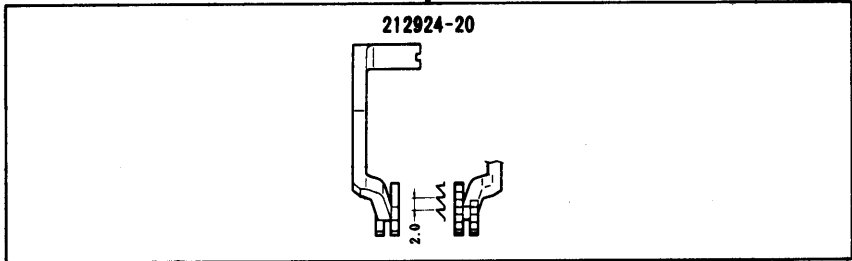
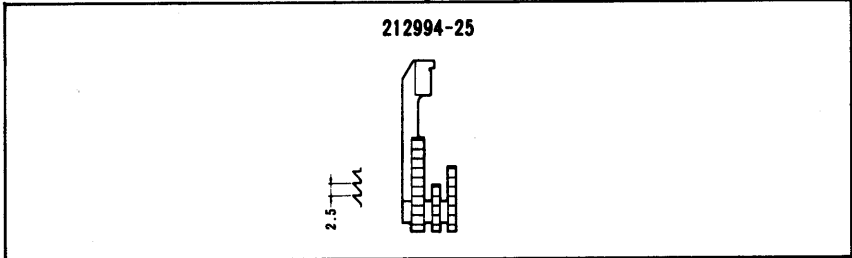
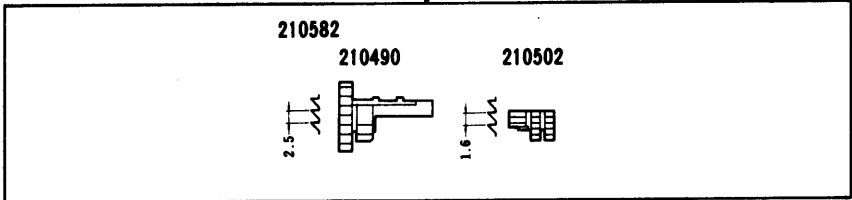
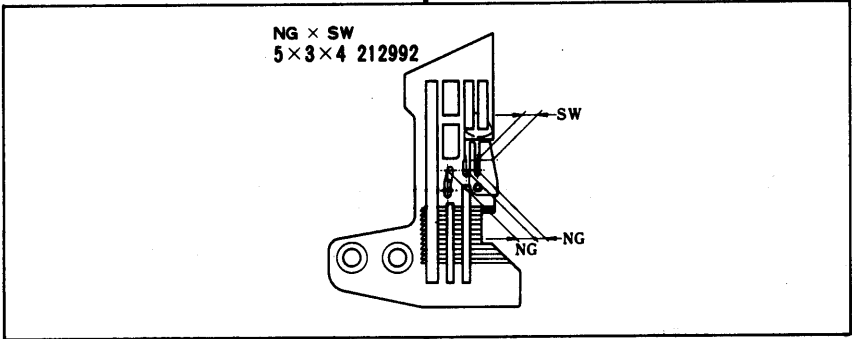



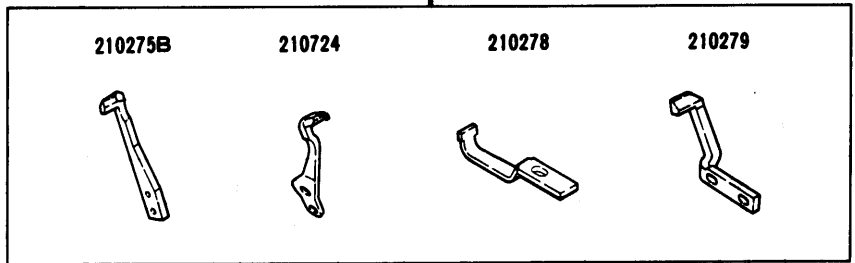
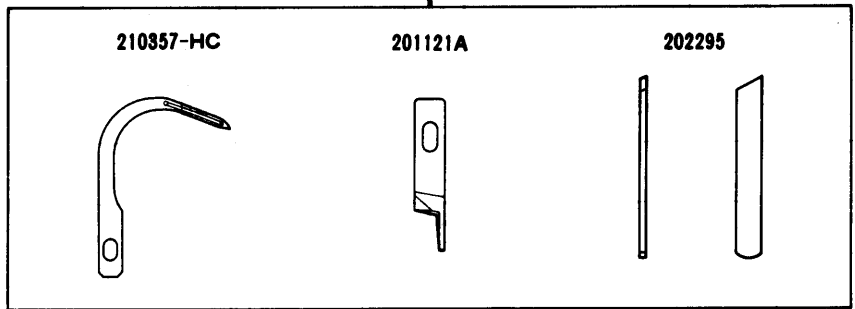
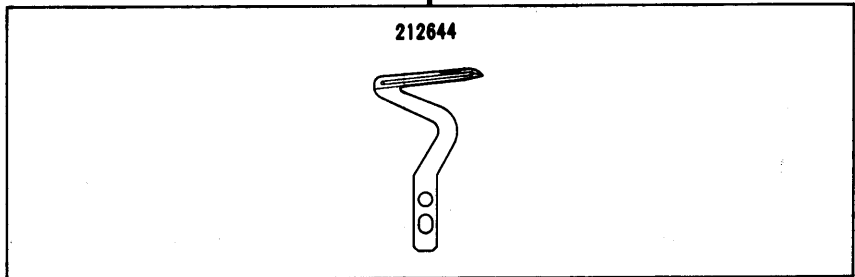
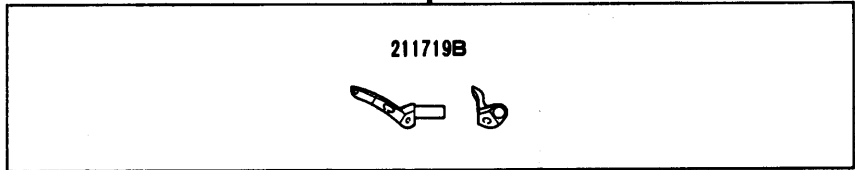
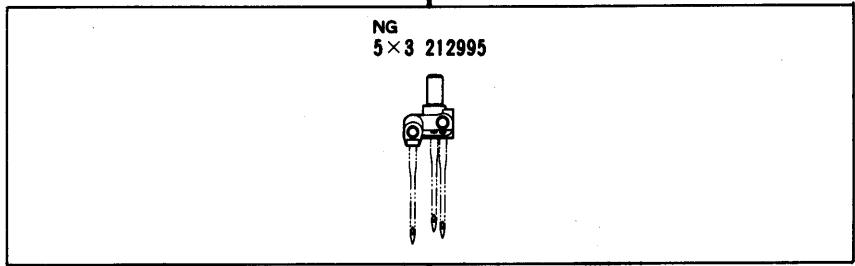







555AFA4



地縫(厚物~極厚物用)

SEAMING (Heavy to extra-heavy)

	 mm	 mm	 mm	 mm	 mm	 mm	 s.p.m.		
ETS32-555AFA4 /455	5 3	4	3.8	0.7~1.5	0.8~1.5	EX	5,500	ジーンズ	Jeans

ETS32-355FA5/453
ETS32-359FA5/453



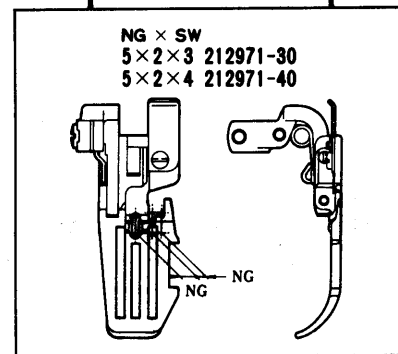
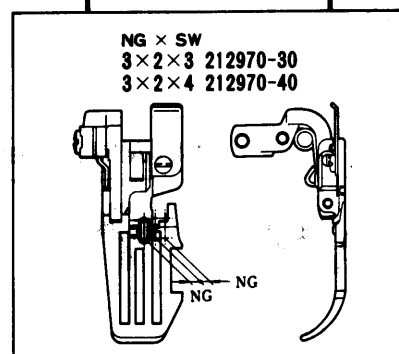
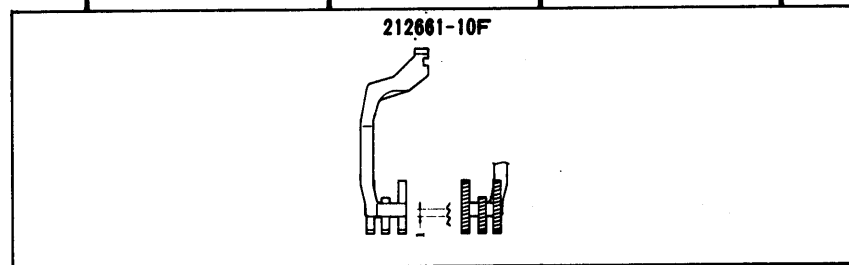
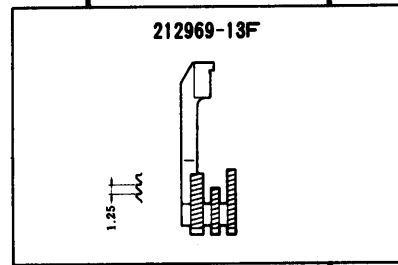
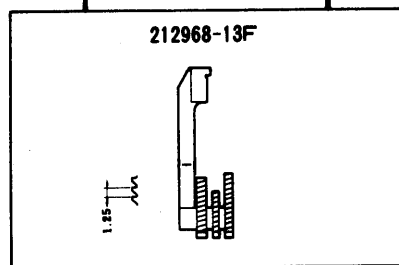
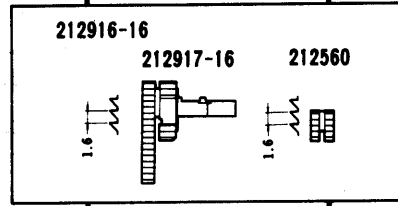
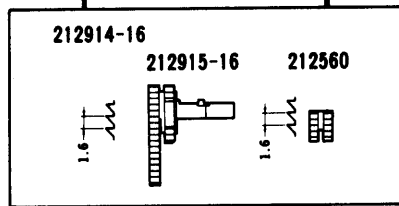
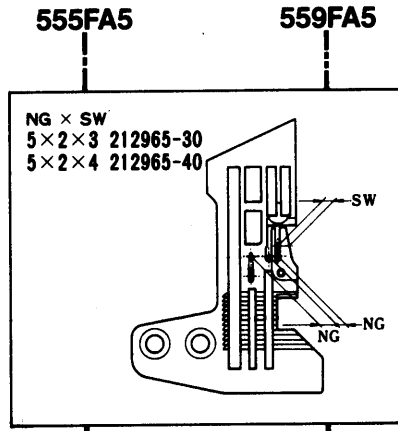
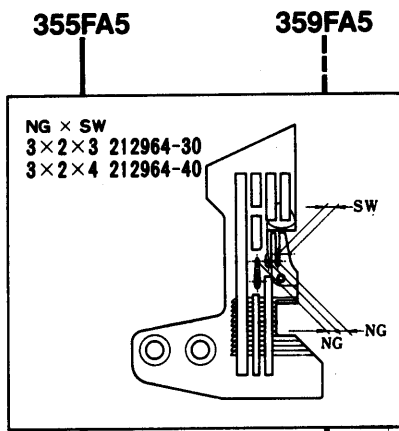

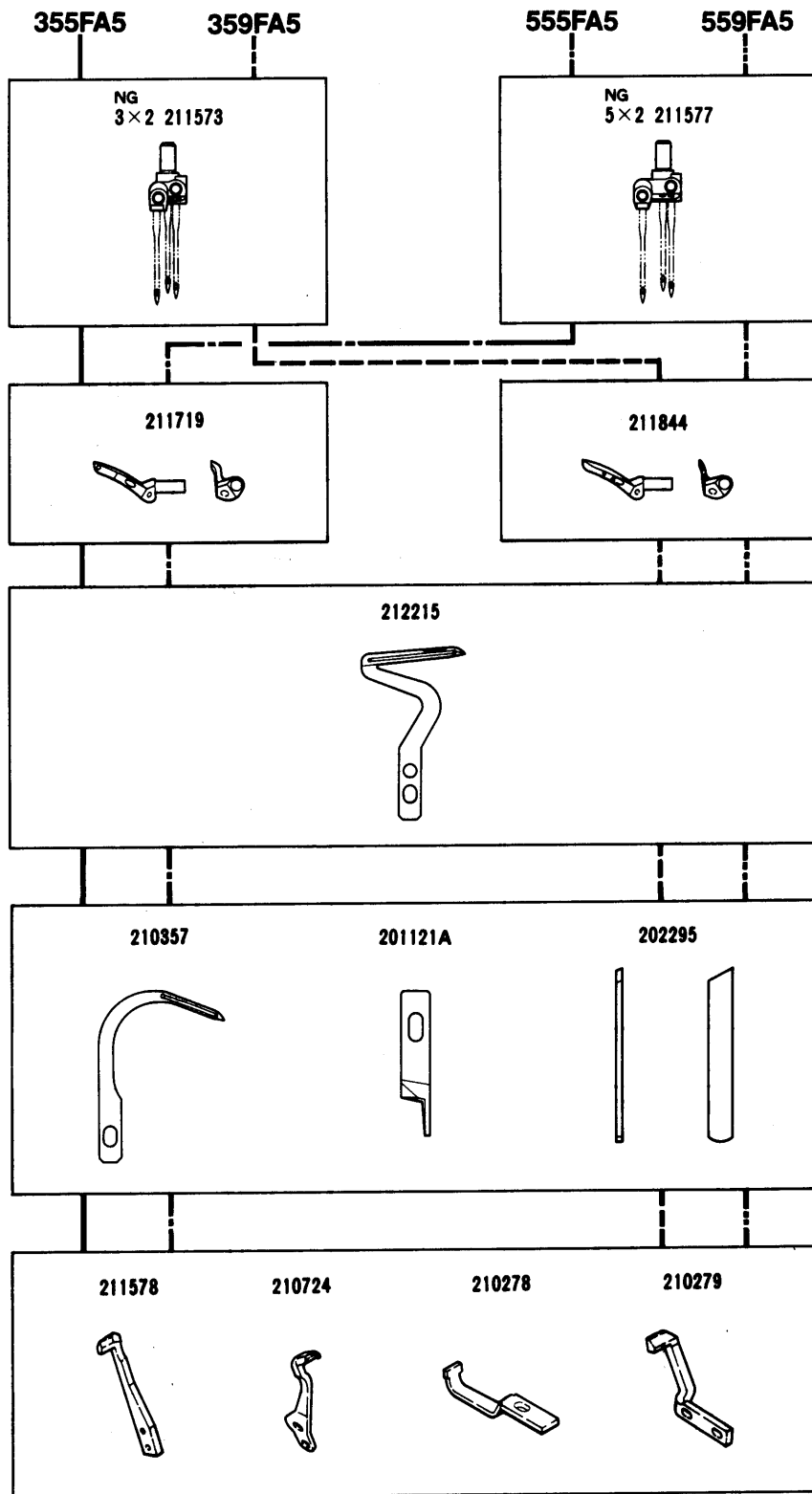





ETS32-555FA5/453
ETS32-559FA5/453





地縫 (中厚物~厚物用)

SEAMING (Medium to heavy)

	 mm	 mm	 mm	 mm	 mm		 s.p.m.			
ETS32-355FA5 /453	3	2	3,4	3.8	0.7~1.5	0.7~2	EX	6,000	セーター	Sweater
ETS32-359FA5 /453	3	2	3,4	〃	〃	〃	〃	〃	セーター	Sweater
ETS32-555FA5 /453	5	2	3,4	〃	〃	〃	〃	〃	ジーンズ	Jeans
ETS32-559FA5 /453	5	2	3,4	〃	〃	〃	〃	〃	ジーンズ	Jeans

ETS32-542FD4/P1(P2)/516-453

542FD4

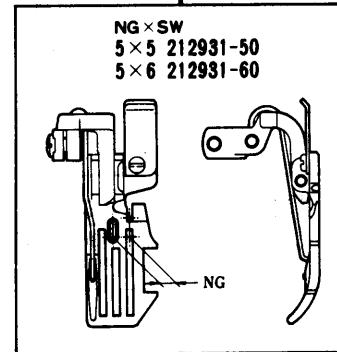
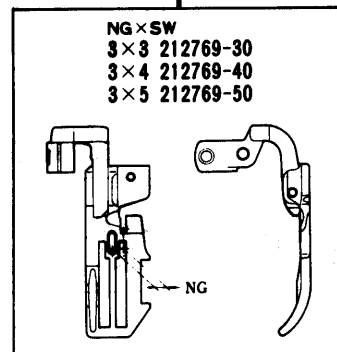
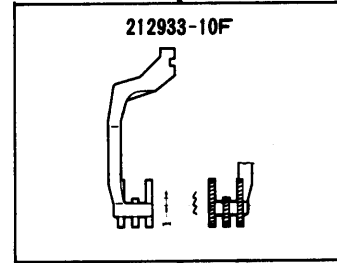
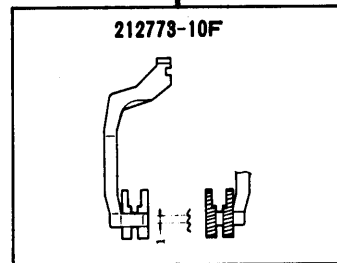
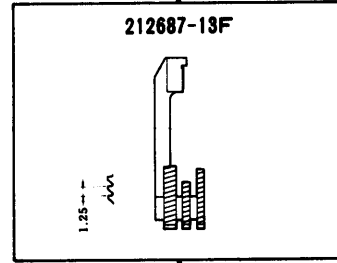
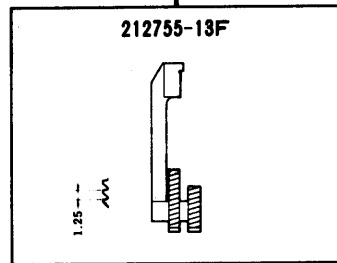
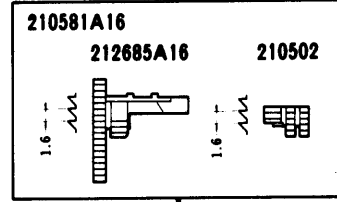
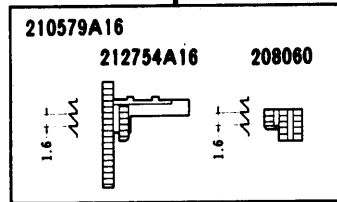
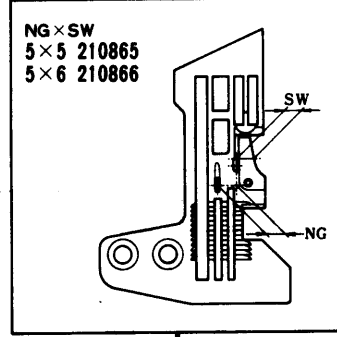
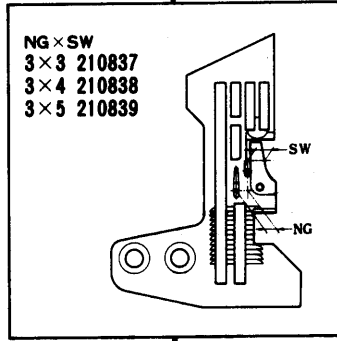

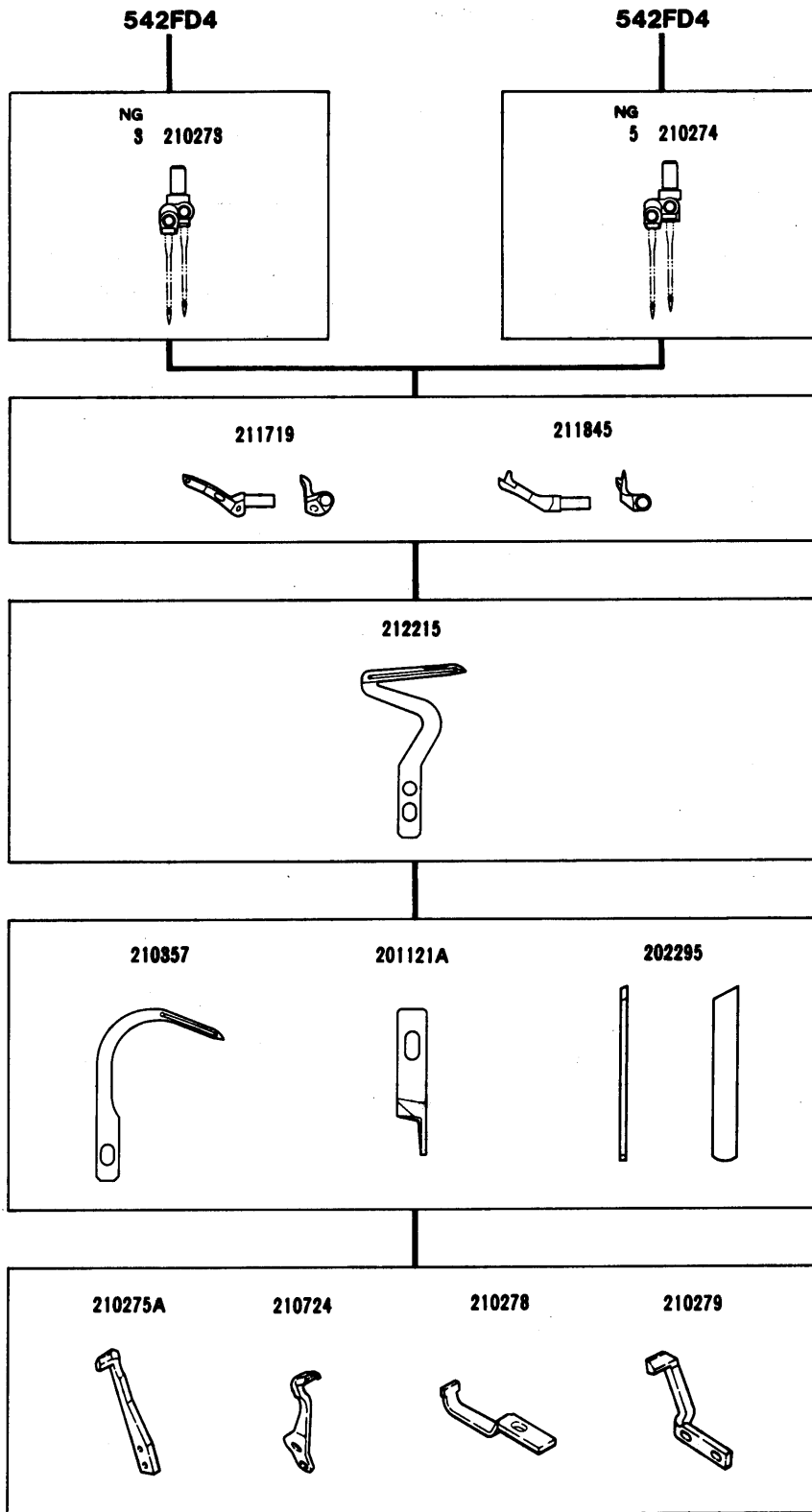

ギャザリング・パイピング

GATHERING・PIPING

ETS32-542FD4/P1(P2) /516-453 515	3	3,4,5	3.8	0.7~2	0.7~2	EX	5,500	トレーニングウェア パジャマ	Sportswear pajamas



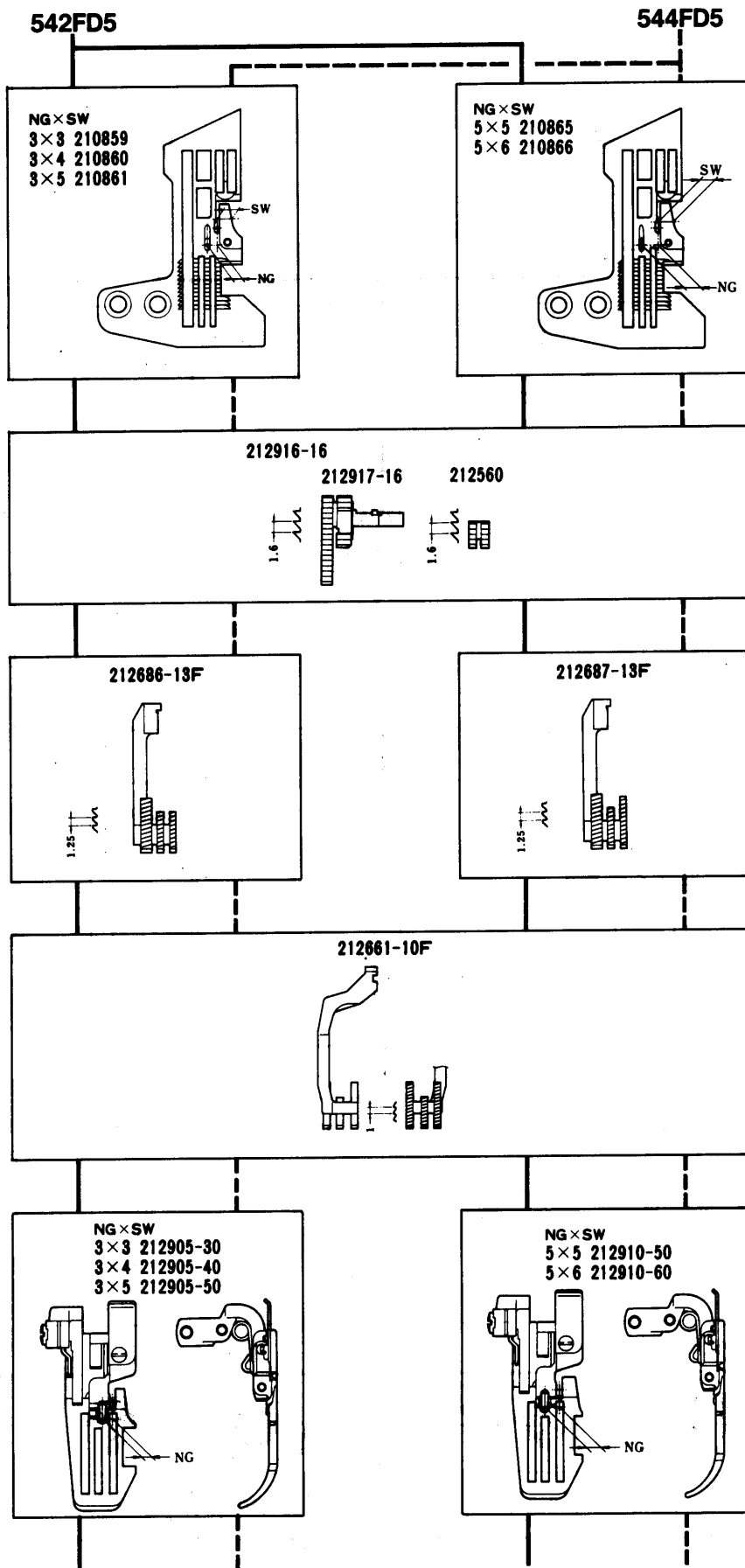

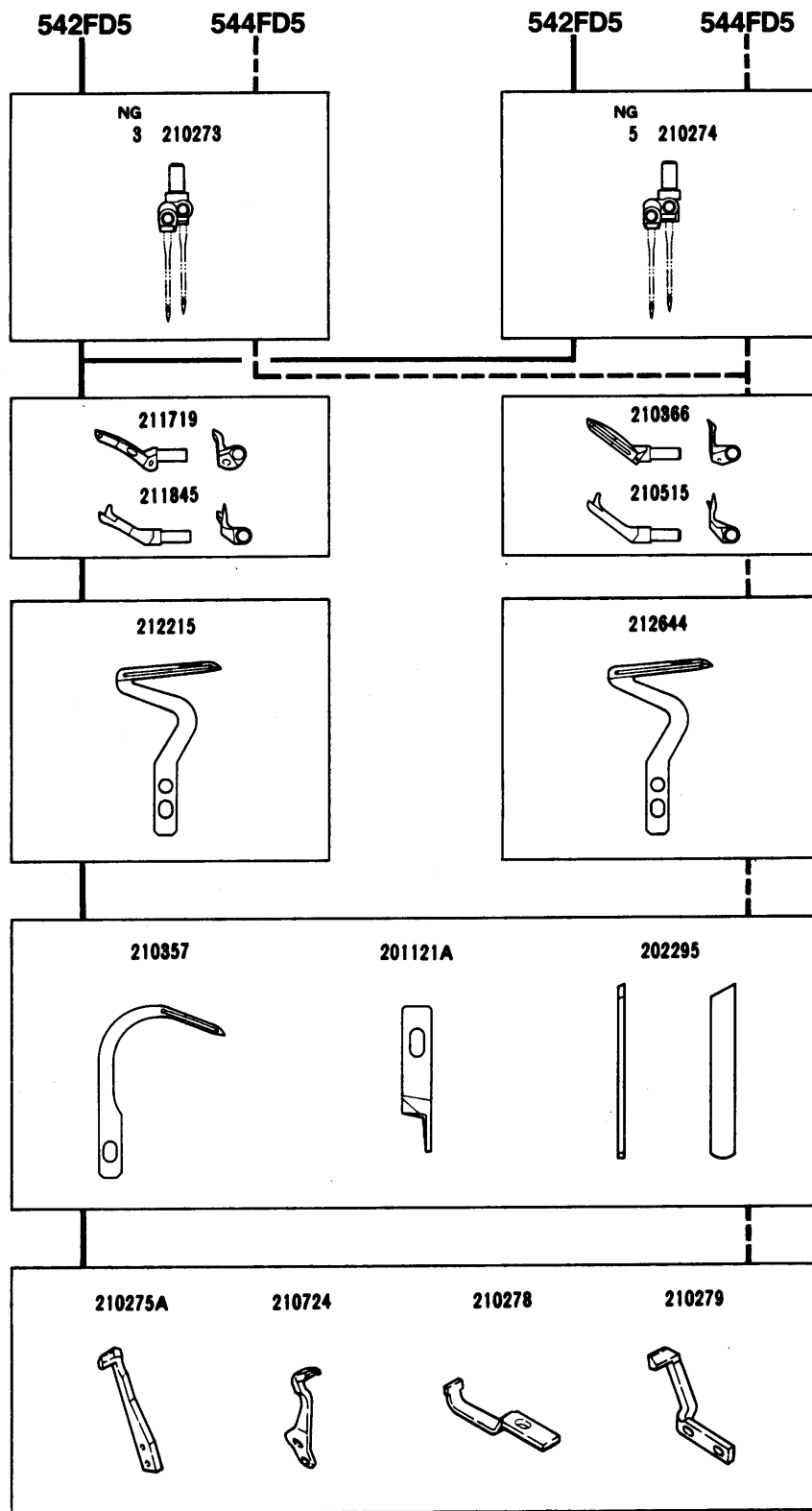





ETS32-542FD5/516-453 ETS32-544FD5/516-353





ギャザリング

GATHERING

	 mm	 mm	 mm	 mm	 mm		 s.p.m.		
ETS32-542FD5 /516-453 515-453	3	3,4,5	3.8	0.7~2	0.7~2	EX	5,500	パジャマ	Pajamas
	5	5,6							
ETS32-544FD5 /516-353 515-353	3	3,4,5	"	"	"	HI	"	ブラウス、子供服	Blouses, children's wear
	5	5,6							

マシンタイプ MACHINE TYPE /SPEC.	カッター NGT SW GAUGE NGT SW		ハリ NEEDLE PLATE	シヤクリン (ワズ) MAIN FEED DOG COMP.	サトウクリン DIFF. FEED DOG	ウツクリン TOP FEED DOG	サシ PRESSER BODY	ウツ UPPER LOOPER	ウツ UPPER SPREADER	シヤ LOWER LOOPER	シヤウクリン 401 LOOPER
	3	4									
ETS32-420FA2 /516-413 /515-413	3	3	212545-30	212753-16	212755-13F	212661-10F	212662-30	211719	211845	212215	210357
	3	4	-40	-40	-40	-40	-40	#38	#29		
	3	5	-50	-50	-50	-50	-50				
ETS32-422FA2 /516-313 /515-313	3	3	212545-30	212753-16	212755-13F	212661-10F	212662-30	210366	210515	212644	210357
	3	4	-40	-40	-40	-40	-40	#26	#27		
	3	5	-50	-50	-50	-50	-50				
ETS32-430FA2 /516-433 /515-433	3	3	212548-30	212684-16	212756-13F	212661-10F	212662-30	211719	211845	212215	210357
	3	4	-40	-40	-40	-40	-40	#38	#29		
	3	5	-50	-50	-50	-50	-50				
ETS32-430FA2A /516-433	5	5	212551-50	212684-16	210494A16	212661-10F	212665-50	211719	-----	212215	210357-HC
	5	6	-60	-60	-60	-60	-60	#38			
ETS32-432FA2 /516-453 /515-453	3	3	212682-30	212684-16	212686-13F	212661-10F	212662-30	211719	211845	212215	210357
	3	4	-40	-40	-40	-40	-40	#38	#29		
	3	5	-50	-50	-50	-50	-50				
ETS32-432FC2/P1(P2) /516-453 /515-453	5	5	212683-50	-	212687-13F	212745A10F	212743-50	211719	211845	212215	210357
	5	6	-60	-	-	-	-	#38	#29		
ETS32-433FA2 /516-353 /515-353	3	3	212682-30	212684-16	212686-13F	212661-10F	212662-30	210366	210515	212644	210357
	3	4	-40	-40	-40	-40	-40	#26	#27		
	3	5	-50	-50	-50	-50	-50				
ETS32-433FC2/P1(P2) /516-353 /515-353	5	5	212683-50	-	212687-13F	212745A10F	212743-50	210366	210515	212644	210357
	5	6	-60	-	-	-	-	#26	#27		
ETS32-434FA2 /516-333 /515-333	3	3	212548-30	212684-16	212756-13F	212661-10F	212662-30	210366	210515	212644	210357
	3	4	-40	-40	-40	-40	-40	#26	#27		
	3	5	-50	-50	-50	-50	-50				
ETS32-542FD2 /516-453/KL100 /515-453/KL100	3	3	212682-30	212684-16	212686-13F	212661-10F	212662-30	211719	211845	212215	210357
	3	4	-40	-40	-40	-40	-40	#38	#29		
	3	5	-50	-50	-50	-50	-50				
ETS32-544FD2 /516-353/KL100 /515-353/KL100	5	5	212683-50	-	212687-13F	212661-10F	212665-50	210366	210515	212644	210357
	5	6	-60	-	-	-	-	#26	#27		



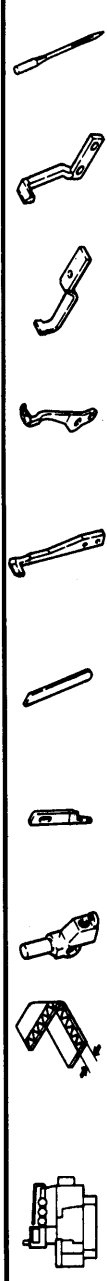

マシンタイプ /SPEC.	ゲージ			ニードル HOLDER	ウッパー KNIFE	ローワー KNIFE	オバ OVL.NDL			フロント FRT.NDL			ガード GUARD	ニードル NEEDLE
	NG/5W	GAUGE	NG/5W				オバ OVL.NDL	フロント FRT.NDL	ガード GUARD	オバ OVL.NDL	フロント FRT.NDL	ガード GUARD		
ETS32-420FA2 /516-413 /515-413	3	3	3	210273	201121A	202295	210275A	210278	210279	210278	210279	DCX27 #11		
	3	4	3		
	3	5	3		
ETS32-422FA2 /516-313 /515-313	3	3	3	210273	201121A	202295	210275A	210278	210279	210278	210279	DCX27 #11		
	3	4	3		
	3	5	3		
ETS32-430FA2 /516-433 /515-433	3	3	3	210273	201121A	202295	210275A	210278	210279	210278	210279	DCX27 #11		
	3	4	3		
	5	5	5	210274		
ETS32-430FA2A /516-433	5	5	5	210274	201121A	202295	210275A	210278	210279	210278	210279	DCX27 #16		
	5	6	5		
	5	6	5		
ETS32-432FA2 /516-453 /515-453	3	3	3	210273	201121A	202295	210275A	210278	210279	210278	210279	DCX27 #11		
	3	4	3		
	5	5	5	210274		
ETS32-432FC2/P1(P2) /516-453 /515-453	3	4	3	210273	201121A	202295	210275A	210278	210279	210278	210279	DCX27 #11		
	3	5	3		
	5	5	5	210274		
ETS32-433FA2 /516-353 /515-353	3	3	3	210273	201121A	202295	210275A	210278	210279	210278	210279	DCX27 #11		
	3	4	3		
	5	5	5	210274		
ETS32-433FC2/P1(P2) /516-353 /515-353	3	4	3	210273	201121A	202295	210275A	210278	210279	210278	210279	DCX27 #11		
	3	5	3		
	5	5	5	210274		
ETS32-434FA2 /516-333 /515-333	3	3	3	210273	201121A	202295	210275A	210278	210279	210278	210279	DCX27 #11		
	3	4	3		
	5	5	5	210274		
ETS32-542FD2 /516-453/KL100 /515-453/KL100	3	3	3	210273	201121A	202295	210275A	210278	210279	210278	210279	DCX27 #11		
	3	4	3		
	5	5	5	210274		
ETS32-544FD2 /516-353/KL100 /515-353/KL100	3	3	3	210273	201121A	202295	210275A	210278	210279	210278	210279	DCX27 #11		
	3	4	3		
	5	5	5	210274		

マシンタイプ /シヨク MACHINE TYPE /SPEC.	ゲージ GAUGE		ハリイ NEEDLE PLATE	シヨクリン (クミ) MAIN FEED DOG COMP.	サトウクリン DIFF. FEED DOG	ウオクリン TOP FEED DOG	オサエ PRESSER BODY	ウ UPPER LOOPER	ウ LOWER LOOPER	ニシユウカン ニシユウカン 401 LOOPER	
	NG	SW									
ETS32-420FA3 /516-413 /515-413	3	3	210837	210579A16	212755-13F	212773-10F	212769-30	211719	211845	212215	210357
	3	4	210838	"	"	"	-40	"	"	"	"
	3	5	210839	"	"	"	-50	"	"	"	"
	3	6	210840	"	"	"	-60	"	"	"	"
ETS32-422FA3 /516-313 /515-313	3	3	210837	210579A16	212755-13F	212773-10F	212769-30	210366	210515	212644	210357
	3	4	210838	"	"	"	-40	"	"	"	"
	3	5	210839	"	"	"	-50	"	"	"	"
	3	6	210840	"	"	"	-60	"	"	"	"
ETS32-430FA3 /516-433 /515-433	3	3	210845	210581A16	212756-13F	212773-10F	212769-30	211719	211845	212215	210357
	3	4	210846	"	"	"	-40	"	"	"	"
	3	5	210847	"	"	"	-50	"	"	"	"
	3	3	210859	210581A16	212686-13F	212773-10F	212769-30	211719	211845	212215	210357
ETS32-432FA3 /516-453 /515-453	3	3	210859	210581A16	212686-13F	212773-10F	212769-30	211719	211845	212215	210357
	3	4	210860	"	"	"	-40	"	"	"	"
	3	5	210861	"	"	"	-50	"	"	"	"
	3	3	210859	210581A16	212756-13F	212773-10F	212769-30	210366	210515	212644	210357
ETS32-433FA3 /516-353 /515-353	3	3	210859	210581A16	212756-13F	212773-10F	212769-30	210366	210515	212644	210357
	3	4	210860	"	"	"	-40	"	"	"	"
	3	5	210861	"	"	"	-50	"	"	"	"
	3	3	210845	210581A16	212756-13F	212773-10F	212769-30	210366	210515	212644	210357
ETS32-434FA3 /516-333 /515-333	3	3	210845	210581A16	212756-13F	212773-10F	212769-30	210366	210515	212644	210357
	3	4	210846	"	"	"	-40	"	"	"	"
	3	5	210847	"	"	"	-50	"	"	"	"
	5	5	213526-50	210582	212994-25	212924-20	213551	211719	211845	212644	210357-HC
ETS32-452FA4 /516-455 /515-455	5	5	213526-50	210582	212994-25	212924-20	213551	211719	211845	212644	210357-HC
	5	6	-60	"	"	"	"	"	"	"	"
	5	7	-70	"	"	"	"	"	"	"	"
	3	3	210859	210581A16	212686-13F	212773-10F	212769-30	211719	211845	212215	210357
ETS32-542FD3 /516-453/KL100 /515-453/KL100	3	3	210859	210581A16	212686-13F	212773-10F	212769-30	211719	211845	212215	210357
	3	4	210860	"	"	"	-40	"	"	"	"
	3	5	210861	"	"	"	-50	"	"	"	"
	3	3	210859	210581A16	212686-13F	212773-10F	212769-30	210366	210515	212644	210357
ETS32-544FD3 516-353/KL100 515-353/KL100	3	3	210859	210581A16	212686-13F	212773-10F	212769-30	210366	210515	212644	210357
	3	4	210860	"	"	"	-40	"	"	"	"
	3	6	210861	"	"	"	-50	"	"	"	"
	3	3	210837	210579A16	212755-13F	212773-10F	212769-30	211719	211845	212215	210357
ETS32-542FD4/P1(P2) /516-453/KL100 /515-543/KL100	3	3	210837	210579A16	212755-13F	212773-10F	212769-30	211719	211845	212215	210357
	3	4	210838	"	"	"	-40	"	"	"	"
	3	5	210839	"	"	"	-50	"	"	"	"
	5	5	210865	210581A16	212687-13F	212933-10F	212931-50	212931-50	211845	212215	210357
	5	5	210865	"	"	"	"	"	"	"	"
	5	6	210866	"	"	"	-60	"	"	"	"

ミシンの型 /シヨウ MACHINE TYPE /SPEC.	ゲージ NG SW		ホルダー NEEDLE HOLDER	ウツメ UPPER KNIFE	シカミ LOWER KNIFE	ボウ OVR. NDL (FRONT)			ニシエカ 401 NDL (FRONT)			ガード GUARD (REAR)			ハリ NEEDLE
	3	4				5	6	210273	201121A	202295	210275A	210724	210278	210279	
ETS32-420FA3 /516-413 /515-413	3	3	210273	201121A	202295	210275A	210724	210278	210279	DCX27 #11					
ETS32-422FA3 /516-313 /515-313	3	3	210273	201121A	202295	210275A	210724	210278	210279	DCX27 #11					
ETS32-430FA3 /516-433 /515-433	3	3	210273	201121A	202295	210275A	210724	210278	210279	DCX27 #11					
ETS32-432FA3 /516-453 /515-453	3	3	210273	201121A	202295	210275A	210724	210278	210279	DCX27 #11					
ETS32-433FA3 /516-353 /515-353	3	3	210273	201121A	202295	210275A	210724	210278	210279	DCX27 #11					
ETS32-434FA3 /516-333 /515-333	3	3	210273	201121A	202295	210275A	210724	210278	210279	DCX27 #11					
ETS32-452FA4 /516-455 /515-455	5	5	210274	201121A	202295	210275A	210724	210278	210279	DCX1 #21					
ETS32-542FD3 /516-453/KL100 /515-453/KL100	3	3	210273	201121A	202295	210275A	210724	210278	210279	DCX27 #11					
ETS32-544FD3 /516-353/KL100 /515-353/KL100	3	3	210273	201121A	202295	210275A	210724	210278	210279	DCX27 #11					
ETS32-542FD4/P1 (P2) /516-453/KL100 /515-453/KL100	3	3	210273	201121A	202295	210275A	210724	210278	210279	DCX27 #11					

マシンタイプ /3307 MACHINE TYPE /SPEC.	ゲージ GAUGE		ハリヤ NEEDLE PLATE	メジャクリン (カミ) MAIN FEED DOG COMP.	サトウクリン DIFF. FEED DOG	ウオクリン TOP FEED DOG	ボヤ PRESSER BODY	ウワ ム-ハ- UPPER LOOPER	ウワ スプレッダ- UPPER SPREADER	シタ ム-ハ- LOWER LOOPER	ニジエウカン ム-ハ- 401 LOOPER	
	NG	SW										
ETS32-430BA2 /516-433 /515-433	3	3	212548-30	212684-16	210494A16	212064-BF	212053	211719 #38	211845 #29	212215	210357	
	3	4	" -40	" "	" "	" "	" "	" "	" "	" "	" "	
	3	5	" -50	" "	" "	" "	" "	" "	" "	" "	" "	
	5	5	212551-50	" "	" "	" "	" "	212056	" "	" "	" "	" "
	5	6	" -60	" "	" "	" "	" "	" "	" "	" "	" "	" "
	5	6	" -60	" "	" "	" "	" "	" "	" "	" "	" "	" "
ETS32-432BA2 /516-453 /515-453	3	3	212682-30	212684-16	210497A16	212064-BF	212053	211719 #38	211845 #29	212215	210357	
	3	4	" -40	" "	" "	" "	" "	" "	" "	" "	" "	
	3	5	" -50	" "	" "	" "	" "	" "	" "	" "	" "	
	5	5	212683-50	" "	" "	" "	" "	212056	" "	" "	" "	" "
	5	6	" -60	" "	" "	" "	" "	" "	" "	" "	" "	" "
	5	6	" -60	" "	" "	" "	" "	" "	" "	" "	" "	" "
ETS32-432BC2/P1(P2) /516-453 /515-453	3	4	212682-40	212684-16	210497A16	212064A13F	212053A	211719 #38	211845 #29	212215	210357	
	3	5	" -50	" "	" "	" "	" "	" "	" "	" "	" "	
	5	5	212683-50	" "	" "	212064B13F	212056A	" "	" "	" "	" "	
	5	6	" -60	" "	" "	" "	" "	" "	" "	" "	" "	
	3	5	212700-50	212684-16	210494A16	212064-BF	212053	211719 #38	211845 #29	212644	210357-HC	
	3	6	" -60	" "	" "	" "	" "	" "	" "	" "	" "	
ETS32-452BA2 /516-433 /515-433	5	5	212701-50	" "	" "	" "	212056	" "	" "	" "	" "	
	5	6	" -60	" "	" "	" "	" "	" "	" "	" "	" "	
	5	7	" -70	" "	" "	" "	" "	" "	" "	" "	" "	
	3	5	212700-50	212684-16	210494A16	212699-13F	211366A	211719 #38	211845 #29	212644	210357-HC	
	3	6	" -60	" "	" "	" "	208955A	" "	" "	" "	" "	
	5	5	212701-50	" "	" "	" "	" "	" "	" "	" "	" "	
ETS32-453BA2 /516-453 /515-453	5	5	" -60	" "	" "	" "	" "	" "	" "	" "	" "	
	5	6	" -70	" "	" "	" "	" "	" "	" "	" "	" "	
	5	7	" -70	" "	" "	" "	" "	" "	" "	" "	" "	
	5	5	212702-50	212684-16	210500A16	212064-BF	212056	211719 #38	211845 #29	212644	210357-HC	
	5	6	" -60	" "	" "	" "	" "	" "	" "	" "	" "	
	5	7	" -70	" "	" "	" "	" "	" "	" "	" "	" "	
ETS32-453BA4 /516-453 /515-453	5	5	212702-50	212684-16	210500A16	212699-13F	208955A	211719 #38	211845 #29	212644	210357-HC	
	5	6	" -60	" "	" "	" "	" "	" "	" "	" "	" "	
	5	7	" -70	" "	" "	" "	" "	" "	" "	" "	" "	
	5	5	212702-50	212684-16	210500A16	212699-13F	208955A	211719 #38	211845 #29	212644	210357-HC	
	5	6	" -60	" "	" "	" "	" "	" "	" "	" "	" "	
	5	7	" -70	" "	" "	" "	" "	" "	" "	" "	" "	

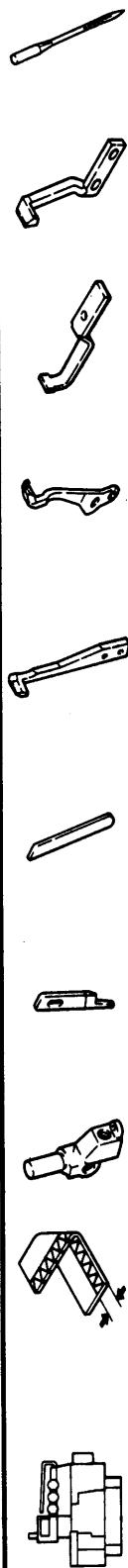

シンクイキ /シヨ MACHINE TYPE /SPEC.	ゲージ		ハルトメ NEEDLE HOLDER	ウツメ UPPER KNIFE	シタメ LOWER KNIFE	オバー			ロウ			ニシヨカシ			ハリ NEEDLE
	NG	SW				オヴァ OVR.NDL (FRONT)	ロウ GUARD (REAR)	ニシヨ 401.NDL (FRONT)	ロウ GUARD (REAR)	ニシヨ 401.NDL (FRONT)	ハリ NEEDLE	ハリ NEEDLE			
ETS32-430BA2 /516-433 /515-433	3	3	210273	201121A	202295	210275A	210724	210278	210279	DCX27 #11					
	3	4	"	"	"	"	"	"	"	"					
	3	5	210274	"	"	"	"	"	"	"					
	5	5	"	"	"	"	"	"	"	"					
	5	6	"	"	"	"	"	"	"	"					
ETS32-432BA2 /516-453 /515-453	3	3	210273	201121A	202295	210275A	210724	210278	210279	DCX27 #11					
	3	4	"	"	"	"	"	"	"	"					
	3	5	210274	"	"	"	"	"	"	"					
	5	5	"	"	"	"	"	"	"	"					
	5	6	"	"	"	"	"	"	"	"					
ETS32-432BC2/P1 (P2) /516-453 /515-453	3	4	210273	201121A	202295	210275A	210724	210278	210279	DCX27 #11					
	3	5	210274	"	"	"	"	"	"	"					
	5	5	"	"	"	"	"	"	"	"					
	5	6	"	"	"	"	"	"	"	"					
	5	6	"	"	"	"	"	"	"	"					
ETS32-452BA2 /516-433 /515-433	3	5	210273	201121A	202295	210275A	210724	210278	210279	OVR:DCX1 #21 401:DCX27 #21					
	3	6	210274	"	"	"	"	"	"	"					
	5	5	"	"	"	"	"	"	"	"					
	5	6	"	"	"	"	"	"	"	"					
	5	7	"	"	"	"	"	"	"	"					
ETS32-452BA4 /516-433 /515-433	3	5	210273	201121A	202295	210275A	210724	210278	210279	OVR:DCX1 #21 401:DCX27 #21					
	3	6	210274	"	"	"	"	"	"	"					
	5	5	"	"	"	"	"	"	"	"					
	5	6	"	"	"	"	"	"	"	"					
	5	7	"	"	"	"	"	"	"	"					
ETS32-453BA2 /516-453 /515-453	5	5	210274	201121A	202295	210275A	210724	210278	210279	OVR:DCX1 401:DCX27 #21					
	5	6	"	"	"	"	"	"	"	"					
	5	7	"	"	"	"	"	"	"	"					
	5	5	210274	201121A	202295	210275A	210724	210278	210279	OVR:DCX1 401:DCX27 #21					
	5	6	"	"	"	"	"	"	"	"					
ETS32-453BA4 /516-453 /515-453	5	5	210274	201121A	202295	210275A	210724	210278	210279	OVR:DCX1 401:DCX27 #21					
	5	6	"	"	"	"	"	"	"	"					
	5	7	"	"	"	"	"	"	"	"					
	5	5	210274	201121A	202295	210275A	210724	210278	210279	OVR:DCX1 401:DCX27 #21					
	5	6	"	"	"	"	"	"	"	"					



マシンタイプ /シボ MACHINE TYPE /SPEC.	ゲージ NG SW GAUGE NG SW	ハリヤ NEEDLE PLATE	シボクリン (クミ) MAIN FEED DOG COMP.	サトウクリン DIFF. FEED DOG	ウツクリン TOP FEED DOG	サキ PRESSER BODY	ウツ UPPER LOOPER	ウツ LOWER SPREADER	シタ LOWER LOOPER	ニシエロカン 401 LOOPER
ETS32-420FA5 /516-413 /515-413	3 3	210837	212914-16	212755-13F	212661-10F	212905-30	211719	211845	212215	210357
	3 4	210838	"	"	"	-40	" #38	" #29	"	"
	3 5	210839	"	"	"	-50	"	"	"	"
	3 6	210840	"	"	"	-60	"	"	"	"
	3 3	210837	212914-16	212755-13F	212661-10F	212905-30	210366	210515	212644	210357
	3 4	210838	"	"	"	-40	" #26	" #27	"	"
ETS32-422FA5 /516-313 /515-313	3 3	210837	212914-16	212755-13F	212661-10F	212905-30	210366	210515	212644	210357
	3 4	210838	"	"	"	-40	"	"	"	"
	3 5	210839	"	"	"	-50	"	"	"	"
	3 6	210840	"	"	"	-60	"	"	"	"
	3 3	210837	212914-16	212755-13F	212661-10F	212905-30	211719	211845	212215	210357
	3 4	210838	"	"	"	-40	" #38	" #29	"	"
ETS32-430FA5 /516-433 /515-433	3 3	210845	212916-16	212756-13F	212661-10F	212905-30	210719	210845	212215	210357
	3 4	210846	"	"	"	-40	"	"	"	"
	3 5	210847	"	"	"	-50	"	"	"	"
	3 5	210851	"	"	"	212910-50	"	"	"	"
	5 5	210852	"	"	"	-60	"	"	"	"
	5 6	210851	212916-16	210494A16	212661-10F	212910-50	211719	-----	212215	210357-HC
ETS32-430FA5A /516-433	5 5	210851	212916-16	210494A16	212661-10F	212910-50	211719	-----	212215	210357-HC
	5 6	210852	"	"	"	-60	" #38	"	"	"
	3 3	210859	212916-16	212686-13F	212661-10F	212905-30	210719	210845	212215	210357
	3 4	210860	"	"	"	-40	"	"	"	"
	3 4	210861	"	"	"	-50	"	"	"	"
	3 5	210865	"	"	"	212910-50	"	"	"	"
ETS32-433FA5 /516-353 /515-353	5 5	210865	212916-16	212687-13F	212661-10F	212910-50	210366	210515	212644	210357
	5 6	210866	"	"	"	-60	" #26	" #27	"	"
	3 3	210859	212916-16	212686-13F	212661-10F	212905-30	210366	210515	212644	210357
	3 4	210860	"	"	"	-40	"	"	"	"
	3 4	210861	"	"	"	-50	"	"	"	"
	3 5	210865	"	"	"	212910-50	"	"	"	"
ETS32-434FA5 /516-333 /515-333	5 5	210865	212916-16	212687-13F	212661-10F	212910-50	210366	210515	212644	210357
	5 6	210866	"	"	"	-60	" #26	" #27	"	"
	3 3	210845	212916-16	212756-13F	212661-10F	212905-30	210366	210515	212644	210357
	3 4	210846	"	"	"	-40	"	"	"	"
	3 4	210847	"	"	"	-50	"	"	"	"
	3 5	210851	"	"	"	212910-50	"	"	"	"
ETS32-542FD5 /516-453/KL100 /515-453/KL100	5 5	210852	212916-16	212687-13F	212661-10F	212910-50	210366	210515	212644	210357
	5 6	210866	"	"	"	-60	"	"	"	"
	3 3	210859	212916-16	212686-13F	212661-10F	212905-30	211719	211845	212215	210357
	3 4	210860	"	"	"	-40	" #38	" #29	"	"
	3 4	210861	"	"	"	-50	"	"	"	"
	3 5	210865	"	"	"	212910-50	"	"	"	"
ETS32-544FD5 /516-353/KL100 /515-353/KL100	5 5	210865	212916-16	212687-13F	212661-10F	212910-50	210366	210515	212644	210357
	5 6	210866	"	"	"	-60	"	"	"	"
	3 3	210859	212916-16	212686-13F	212661-10F	212905-30	211719	211845	212215	210357
	3 4	210860	"	"	"	-40	" #38	" #29	"	"
	3 4	210861	"	"	"	-50	"	"	"	"
	3 5	210865	"	"	"	212910-50	"	"	"	"

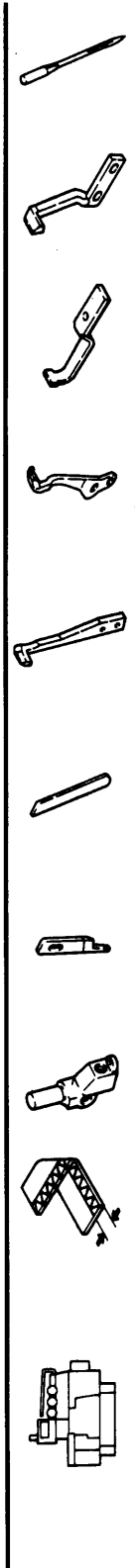

マシンタイプ /SPEC.	ゲージ		ホルダー	ウッパー KNIFE	ローワー KNIFE	オーバー		ガード		NDL		ニードル
	NG	SW				FRONT	REAR	FRONT	REAR	FRONT	REAR	
ETS32-420FA5 /516-413 /515-413	3	3	210273	201121A	202295	210275A	210724	210278	210279	210278	210279	DCX27 #11
	3	4	"	"	"	"	"	"	"	"	"	"
	3	5	"	"	"	"	"	"	"	"	"	"
ETS32-422FA5 /516-313 /515-313	3	3	210273	201121A	202295	210275A	210724	210278	210279	210278	210279	DCX27 #11
	3	4	"	"	"	"	"	"	"	"	"	"
	3	5	"	"	"	"	"	"	"	"	"	"
ETS32-430FA5 /516-433 /515-433	3	3	210273	201121A	202295	210275A	210724	210278	210279	210278	210279	DCX27 #11
	3	4	"	"	"	"	"	"	"	"	"	"
	5	5	210274	"	"	"	"	"	"	"	"	"
ETS32-430FA5A /516-433	5	5	210274	201121A	202295	210275A	210724	210278	210279	210278	210279	DCX27 #16
	5	6	"	"	"	"	"	"	"	"	"	"
ETS32-432FA5 /516-453 /515-453	3	3	210273	201121A	202295	210275A	210724	210278	210279	210278	210279	DCX27 #11
	3	4	"	"	"	"	"	"	"	"	"	"
	3	5	210274	"	"	"	"	"	"	"	"	"
ETS32-433FA5 /516-353 /515-353	3	3	210273	201121A	202295	210275A	210724	210278	210279	210278	210279	DCX27 #11
	3	4	"	"	"	"	"	"	"	"	"	"
	5	5	210274	"	"	"	"	"	"	"	"	"
ETS32-434FA5 /516-333 /515-333	3	3	210273	201121A	202295	210275A	210724	210278	210279	210278	210279	DCX27 #11
	3	4	"	"	"	"	"	"	"	"	"	"
	5	5	210274	"	"	"	"	"	"	"	"	"
ETS32-542FD5 /516-453/KL100 /515-453/KL100	3	3	210273	201121A	202295	210275A	210724	210278	210279	210278	210279	DCX27 #11
	3	4	"	"	"	"	"	"	"	"	"	"
	3	5	210274	"	"	"	"	"	"	"	"	"
ETS32-544FD5 /516-353/KL100 /515-353/KL100	3	3	210273	201121A	202295	210275A	210724	210278	210279	210278	210279	DCX27 #11
	3	4	"	"	"	"	"	"	"	"	"	"
	5	5	210274	"	"	"	"	"	"	"	"	"

マシンタイプ /シボ /SPEC.	ゲージ GAUGE		ナリタ NEEDLE PLATE	シボクリハ (クミ)	サトウクリハ DIFF. FEED DOG	ウオクリハ TOP FEED DOG	オサエ PRESSER BODY	ウウ UPPER LOOPER	ウウ UPPER SPREADER	シタ LOWER LOOPER	ニシエウカン #401 LOOPER
	NG	SW									
ETS32-355FA5 /453	3	2 3	212964-30 -40	212914-16	212968-13F	212661-10F	212970-30 -40	211719 #38	-----	212215	210357
	3	2 4									
ETS32-359FA5 /453	3	2 3	212964-30 -40	212914-16	212968-13F	212661-10F	212970-30 -40	211844 #42	-----	212215	210357
	3	2 4									
ETS32-555AFA4 /455	5	3 4	212992	210582	212994-25	212924-20	213552	211719B #38B	-----	212644	210357-HC
	5	2 3	212965-30 -40	212916-16	212969-13F	212661-10F	212971-30 -40	211719 #38	-----	212215	210357
ETS32-559FA5 /453	5	2 3	212965-30 -40	212916-16	212969-13F	212661-10F	212971-30 -40	211844	-----	212215	210357
	5	2 4									

マシンタイプ /シボ /SPEC.	ゲージ GAUGE		ナリタ NEEDLE HOLDER	ウキス UPPER KNIFE	シタス LOWER KNIFE	オハ OVR. NDL (FRONT)		ウウ GUARD (REAR)		ニシエウカン 401 NDL (FRONT)		ナリ NEEDLE
	NG	SW				OVR. NDL (FRONT)	GUARD (REAR)	ニシエウカン (FRONT)	ニシエウカン (REAR)			
ETS32-355FA5 /453	3	2 3	211573	201121A	202295	211578	210724	210724	210278	210278	DCX27 #11	
	3	2 4										
ETS32-359FA5 /453	3	2 3	211573	201121A	202295	211578	210724	210724	210278	210278	DCX27 #11	
	3	2 4										
ETS32-555AFA4 /455	5	3 4	212995	201121A	202295	210275B	210724	210724	210278	210278	DCX1 #21 (OVR.) DCX27#21 (401)	
	5	2 3	211577	201121A	202295	211578	210724	210724	210278	210278	DCX27 #11	
ETS32-559FA5 /453	5	2 3	211577	201121A	202295	211578	210724	210724	210278	210278	DCX27 #11	
	5	2 4										

■ PEGASUS
SEWING MACHINE MFG.
CO., LTD.®

