

取扱説明書
&
パーツブック

INSTRUCTIONS
&
PARTS BOOK

AZR8920G

後ろ引き上下差動送り
2本針2重環縫いミシン
2 Needle Double Chainstitch Machine
With Variable Rear Top-Feeder

AZF8500Gの取扱説明書と調整が異なる部分を記載しています。

AZF8500Gの取扱説明書とあわせてご使用下さい。

Adjustments different with AZF8500G are mentioned in this book.

Read this book in combination with INSTRUCTIONS of AZF8500G.

取扱説明書は全て保管しておいて下さい。

安全にお使い頂くため、

最後までよくお読みになってからご使用下さい。

SAVE ALL INSTRUCTION MANUALS.

READ and UNDERSTAND

THOROUGHLY to OPERATE for SAFE USE.



ヤマトミシン製造株式会社
YAMATO SEWING MACHINE MFG. CO., LTD.

1. Proper operation

1-1 Setting of tape



*Cutting the tip of tape as illustrated below makes easy to run the tape through folder.

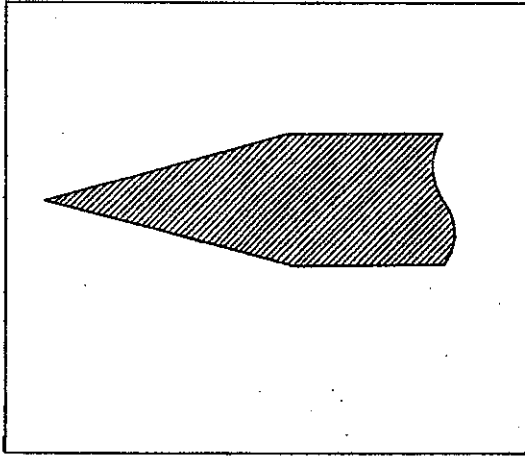

1. Run the tape through folder after through the tape guide as shown below.
2. Pull out the end of tape to (machine's) feeding direction gently and get the tape folded in four underneath raised presser foot. Then, lower the presser foot.

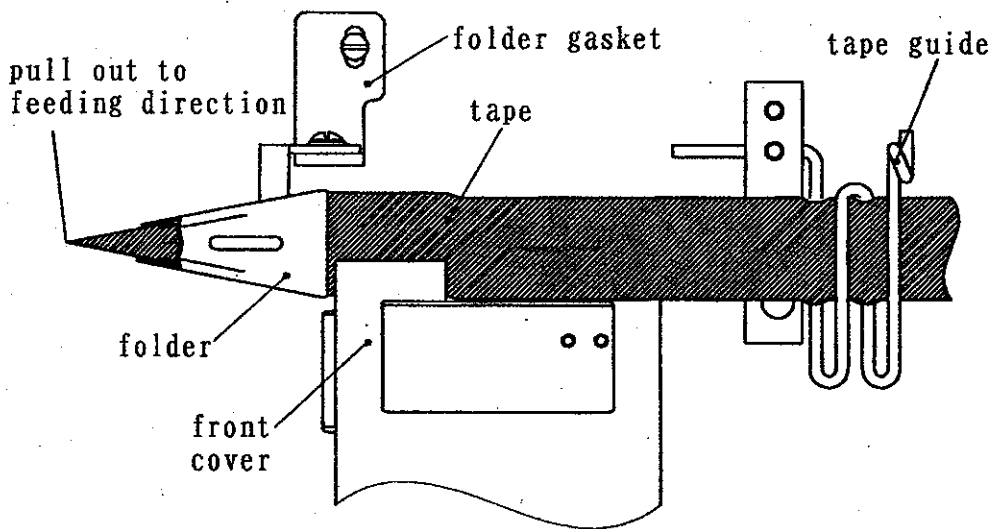

2. Adjustment of sewing machine



WARNING

ALWAYS turn OFF the motor switch and check that the motor stops before the work.

2-1 Needle thread tension for double chainstitch

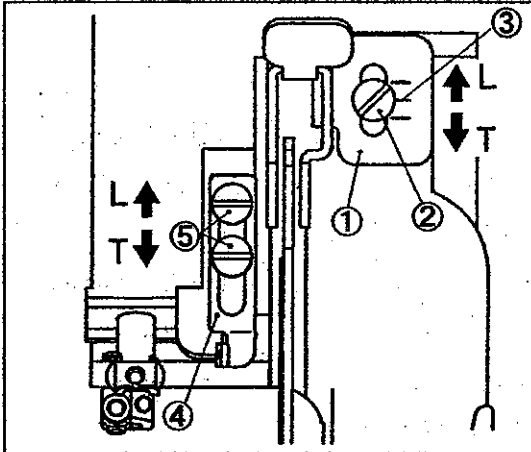

- ☆ At the standard position of needle thread eyelet①, the notch mark③ lines up to the center of screw②.
- ☆ Set double chainstitch needle thread eyelet (left)④ to make needle thread being level with eyelet④ at the top dead point of needle bar. To adjust it, loosen screw⑤.
- ☆ At the standard position of needle thread pull-off⑥, its portion for thread pull-off⑦ lines up to the eye⑧ on eyelet (right), when the pull-off is forward completely. To adjust it, loosen screw⑨.
- * Moving needle thread eyelet and needle thread pull-off to the direction "T" tightens the needle thread tension and moving them to "L" loosens the tension.

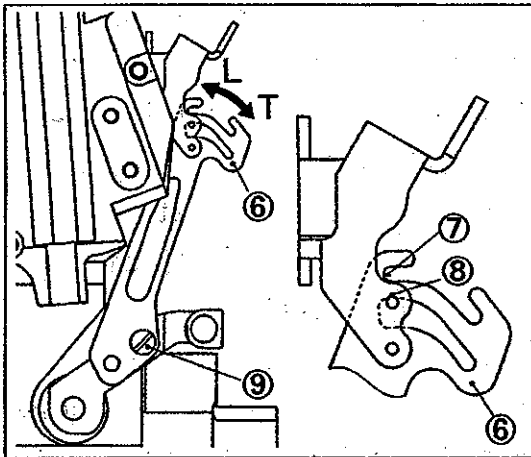

2-2 Looper thread tension for double chainstitch

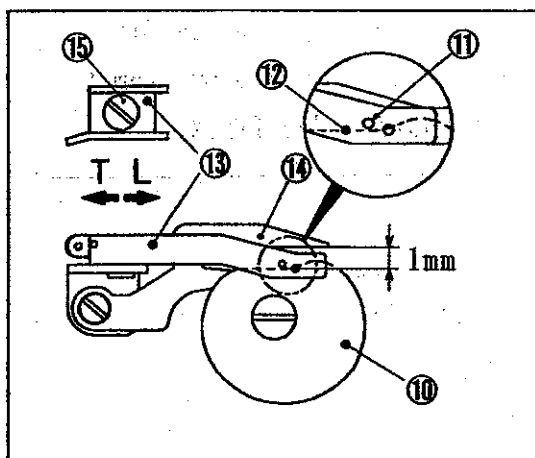

- ☆ Set the bottom of eye⑪ on looper thread eyelet⑬ to lines up to the surface⑫ of looper thread take-up⑩ when the surface⑫ is being in level.
- ☆ Set thread retaining finger⑭ at the point 1 mm above the center of eye on looper thread eyelet⑬.
- ☆ At the standard position, the center of slot on looper thread eyelet⑬ lines up to the center of screw⑮.
- * Moving looper thread eyelet⑬ to direction "L" loosens the looper thread tension and moving it to "T" tightens the tension.

2. Adjustment of sewing machine



WARNING

ALWAYS turn OFF the motor switch and check that the motor stops before the work.

2-3 Adjustment of folder



- ☆ The position for installing the folder is according to folding style and the tape width.
- ☆ If the tape is folded uneven, make sure lower tape outlet④ of folder② is set lower than the surface of stitch plate.
- ☆ Adjust the position of knife(=trimming width) according to finishing width of tape.

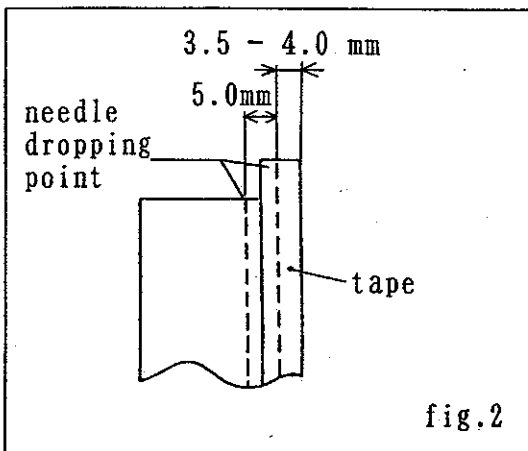
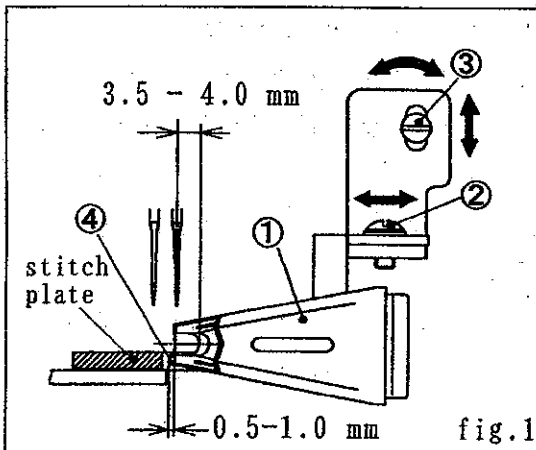

How to adjust

- ☆ Loosen screw② and adjust the right and left position of folder.
- ☆ Loosen screw③ and adjust the up-and-down position and tilt in right and left of folder.
- ☆ For up-and-down position, adjust folder① so that its lower tape outlet④ is set below the surface of stitch plate.
- ☆ For the tilt, to obtain finish with the tape sewn wider on bottom(=narrower on top, See fig.3), adjust folder so that its lower tape outlet is set closer to stitch plate for 0.5 - 1.0 mm than upper outlet.
- ☆ For the right and left position, set folder① to make the distance of 3.5-4.0 mm between the right needle and the inmost part of tape outlet of folder①.

NOTE for your reference...

With the tape width 25 mm, right needle stitch is on the line 3.5 - 4.0 mm from the right edge at standard. See fig.2.

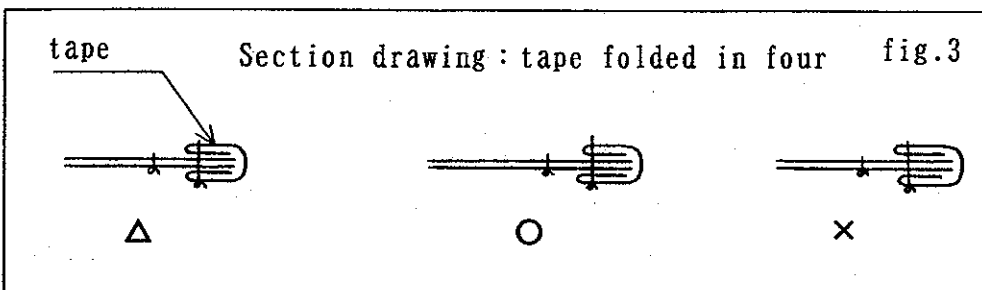

2. Adjustment of sewing machine



WARNING

ALWAYS turn OFF the motor switch and check that the motor stops before the work.

2-4 Adjustment of needle height

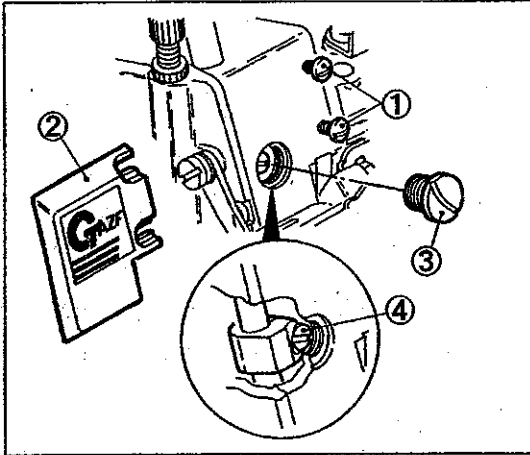

1. Loosen screws① and remove logo plate②.
2. Remove screw③.
3. Rotate machine pulley manually to position the needle bar at its top dead point.
4. Loosen screw④ and adjust the needle bar in up and down.

《AZR8920G class》

Set the needle height from the top surface of stitch plate to the tip of right needle to be 9.6 - 9.8 mm at the top of its stroke.

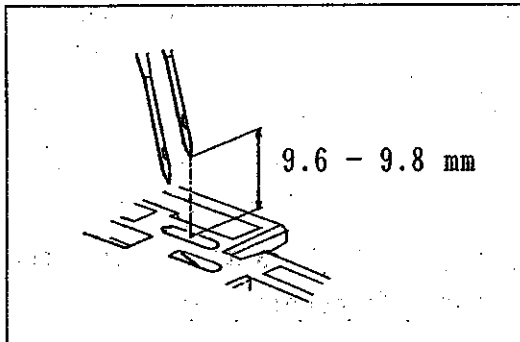

CAUTION

The tightening torque of screw on needle bar connecting bracket is 1.5 N·m(15kgf·cm).

2. Adjustment of sewing machine



WARNING

ALWAYS turn OFF the motor switch and check that the motor stops before the work.

2-5 Needle and double chaining looper

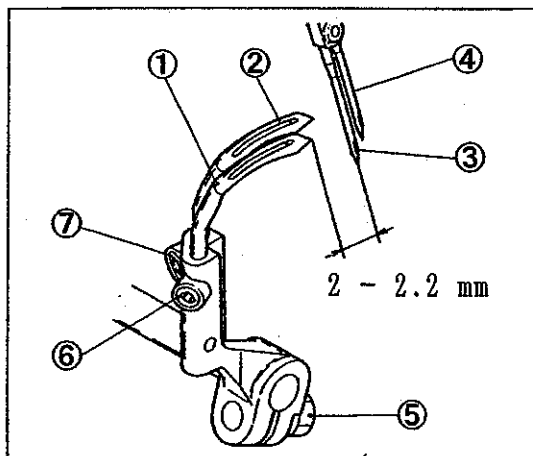

★Timing

Insert double chaining loopers ① and ② to looper holder and the height of them are fixed by their touching to the bottom of holder. Loosen screw ⑤ and adjust looper ① and ② to make the distance of 2.0 - 2.2 mm between the center of left double chaining needle ③ and the tip of left looper ① at the leftmost point of their stroke.

On this adjustment, tighten screws ⑥ and ⑦ on loopers to fix looper ① and ② temporarily with the angle approximately 2° , and adjust the distance between needles and loopers ① and ② with adjusting the longitudinal position of the tip of loopers and needles.

The position of right double chaining looper ① is set automatically according to the distance between needle and left double chaining looper ②.

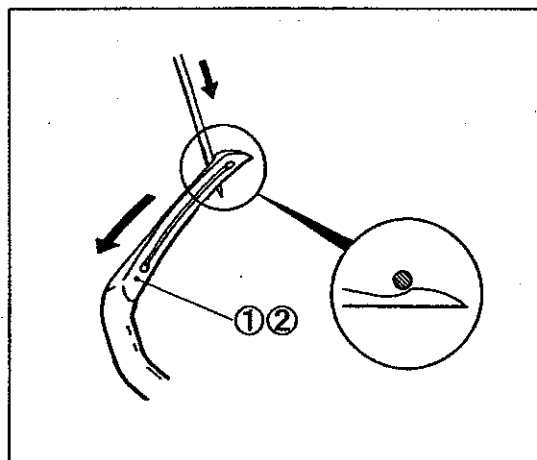

★Longitudinal position

The tips of loopers ① and ② pass behind of needles as closely as possible without contact. The loopers pass in front of needles as contact slightly with their curved portions on the ways of loopers right to left.

2. Adjustment of sewing machine



WARNING

ALWAYS turn OFF the motor switch and check that the motor stops before the work.

2-6 Adjustment of lifting amount of presser foot

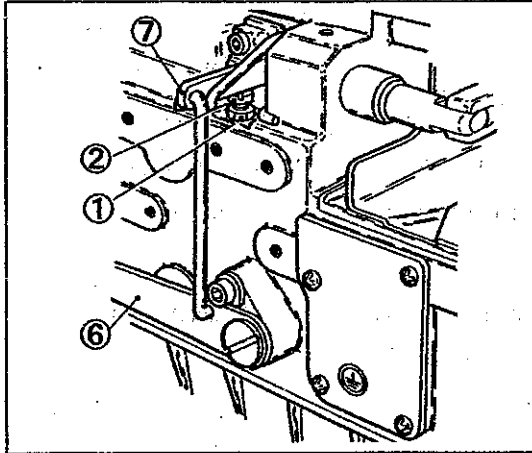

For AZR8920G, maximum lifting amount of presser foot is 3.5 mm.

1. Loosen lock nut① and rotate screw② clockwise.
2. Loosen screws④ and ⑤ on stopper③ of presser foot arm.
3. Push down presser foot lever⑥ and make bottom surface of presser foot to be parallel with the stitch plate and to be 3.5 mm above the top surface of stitch plate.
4. With presser foot is lifted up 3.5 mm, rotate screw② counterclockwise until its top surface contacts presser foot shaft lever⑦.
5. Tighten lock nut①.
6. With presser foot is lifted up 3.5 mm, make the clearance of 0.2 mm between presser foot arm⑧ and stopper③.
7. Tighten screws④ and ⑤ on presser foot arm stopper③.

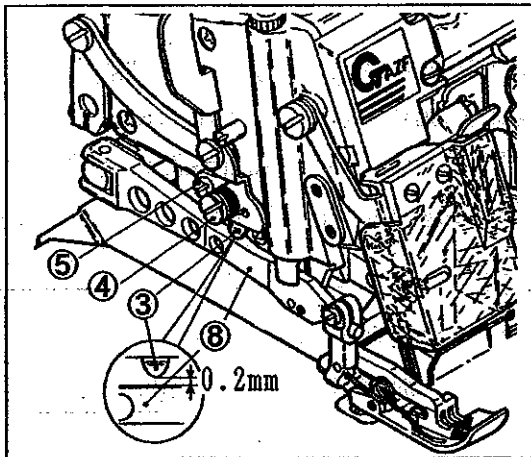

3 . Adjustment of top feeding



WARNING

ALWAYS turn OFF the motor switch and check that the motor stops before the work.

3-1 Adjustment of top feeding amount against lower feed

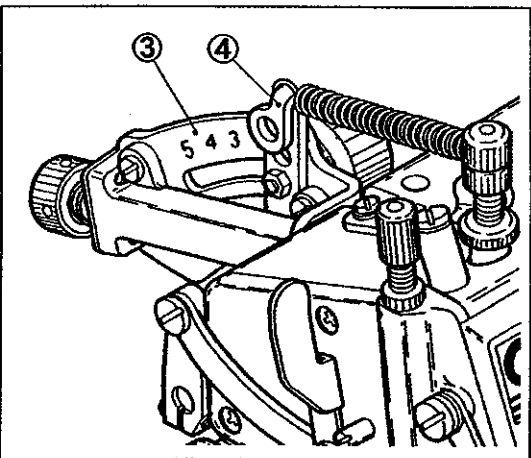
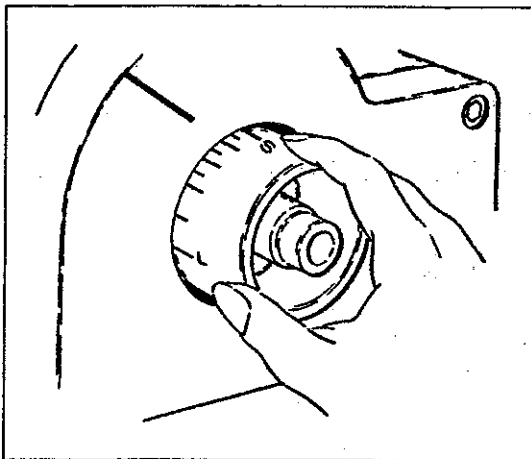
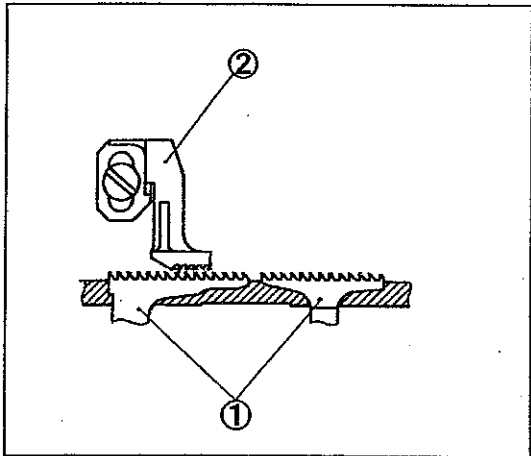

For AZR8920G, top feed and lower feed drives separately. See the following points.

- ☆ When the feeding amount of lower feed (stitch length) is changed, the feeding amount of top feed has to be changed accordingly.
- ☆ The standard ratio of lower feeding to the top feeding is 1:1.
- ☆ The actual feeding amount of top feed② is twice of the number indicated on top feed graduation③.
- ☆ When the graduation of pulley is at “2” (stitch length: 2mm), set the top feed lever④ at “1” on top feed graduation③.

*Maximum top feeding amount : 7.0 mm.

CAUTION

According to the material to be sewn, change the position of top feed lever④ slightly.

CAUTION

Increasing top feeding amount makes locus of top feed to be extended backward without changing the front point of top feed.

locus of top feeding

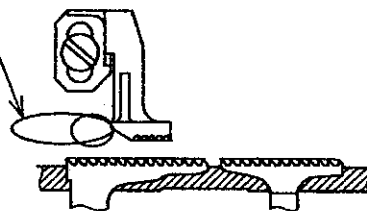

3 . Adjustment of top feeding



WARNING

ALWAYS turn OFF the motor switch and check that the motor stops before the work.

3-2 Adjustment of clearance between top feed dog and lower feed dog

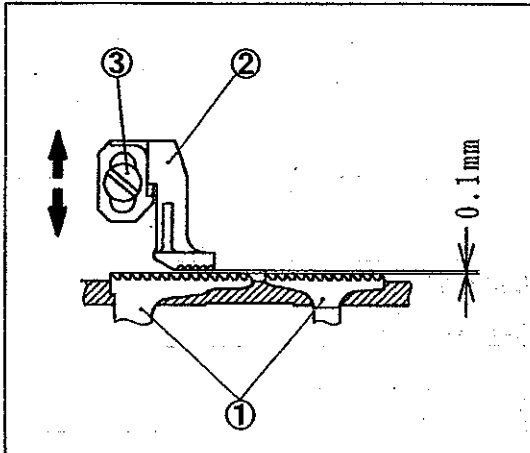

Stable feeding can be obtained by adjusting the height of top feed dog according to the application, type and weight of fabric to be sewn.

The clearance between the top feed dog and the lower feed dog should be 0.1 mm when the top feed is at bottom dead point and the lower feed is at top dead point.

For adjustment, loosen screw③.

3-3 Adjustment of up and down movement of top feed dog

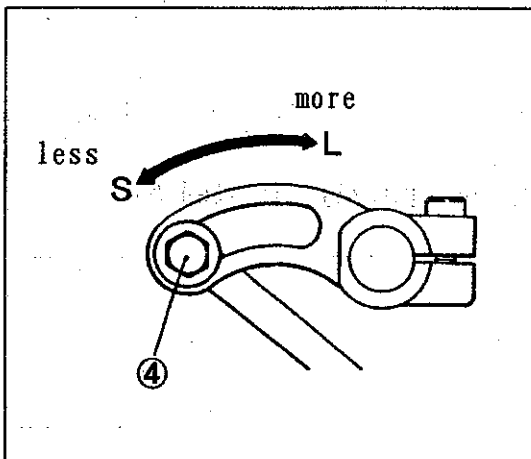

Up and down movement of top feed dog can be adjusted from 3.5 mm to 6.0 mm.

For adjustment, remove top cover, loosen screw④ and moving it to the direction "L" increases the moving amount and to the direction "S" decreases it.

4 . Specifications

Model	AZR8920G-CDF
Dimensions	380(L) × 245(W) × 310(H) mm
Weight	28kg
Construction	Dust-proof, Oil-tight and Completely Sealed
Stitch Type	ISO(401·401)
Application	Piping Operation of pockets with woven fabrics
Sewing Speed	6,500 r.p.m.
Stitch Length	1.0 - 4.0 mm 6.5 - 25 stitches per inch 7.5 - 30 stitches per 30 mm
Sharpest Curve to be sewn	45R
Sewing Width	25 mm of tape width → 10 mm(standard) 30 mm of tape width → 12.5 mm (optional)
Needle Distance	5 mm
Needle System	DC×27, Size65 - 90(#9 - #14)
Needle Stroke	25.7 mm
Presser Foot Lift	3.5 mm(max.)
Adjustment of Stitch Length	Push Button System
Differential Ratio	Normal Differential(Gathering) 1 : 2.3 Reverse Differential(Stretching) 1 : 0.7
Adjustment of Differential Ratio	·Adjustment during the rotation is also available by lifting and lowering lever. ·Differential feed can be easily and quickly adjusted by Lever or Micro-Adjuster.
Feeding Amount of Top Feed Dog	7.0 mm
Basis of Top Feed Movement	Front of Locus
Up and Down Movement of Top Feed Dog	3.5 - 6.0 mm
Lifting Amount of Top Feed Dog	7.0 - 7.5 mm
Knives for Cutting Fabric	Lower Knife : Flat Type, made of Special Steel Upper Knife : Flat Type, made of Super Hard Alloy
Lubrication Oil	YAMATO SF OIL No.28
Capacity of Oil Reservoir	900CC
Lubrication	Automatic Lubrication System Forced fed by Gear Pump in combination with Splash Lubrication
Installation	Table Top Type Fully-submerged type / Semi-submerged type

1
AZR8920G(1)

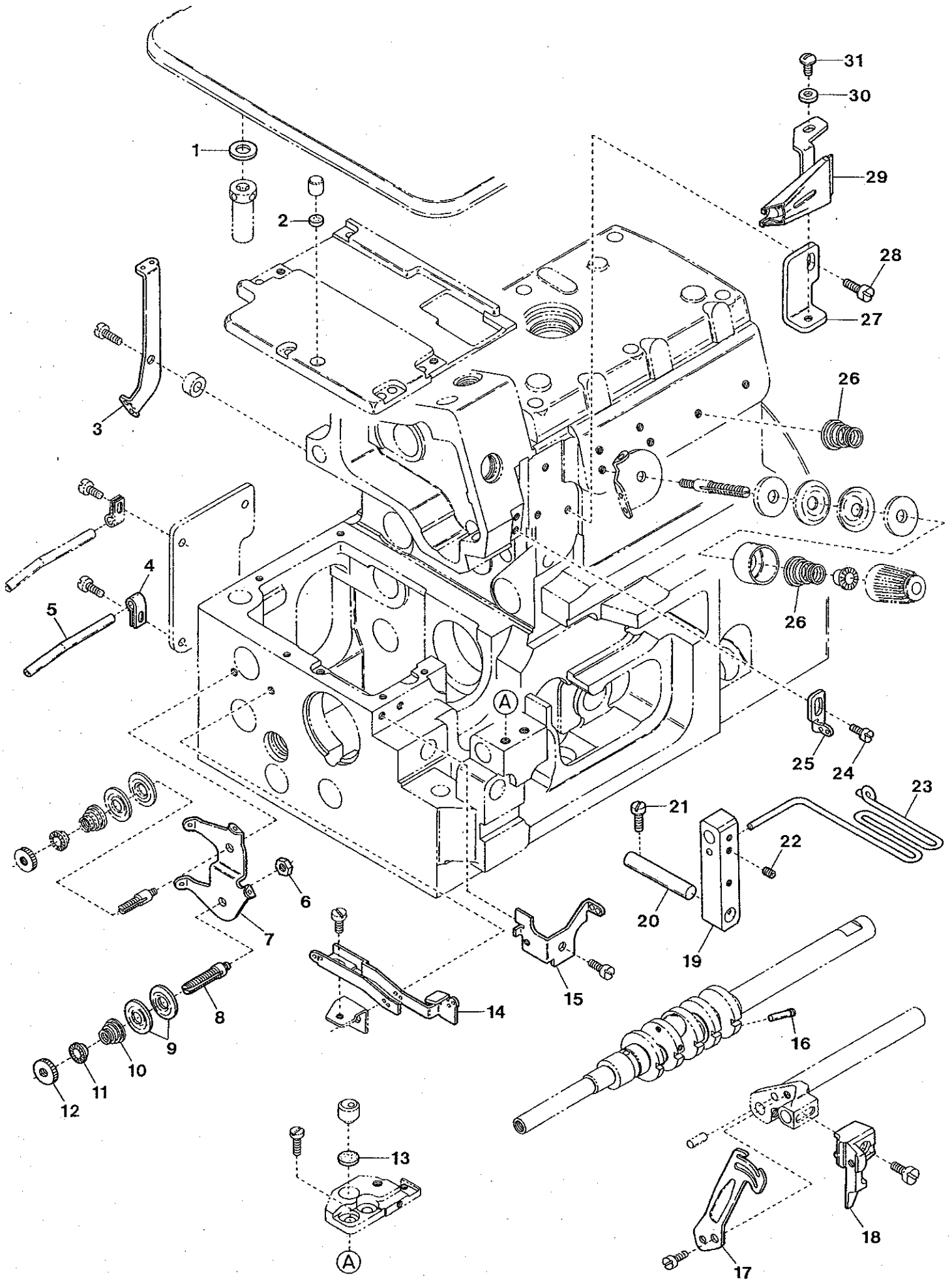

AZR8920G(1) EXCLUSIVE PARTS

サブクラス専用部品(1)

Ref.	Parts			Amt.
No.	No.	Description	品名	Req.
1	300040	Washer	ワッシャ	1
2	000933	Rubber Cushion(Medium)	埋メ座 (中)	1
3	2150301	Chaining Looper Thread Eyelet(Rear)	二重環ルーパ縫(後)	1
4	0093528	Looper Thread Pipe Stay	糸道パイプ支エ	1
5	0021735	Looper Thread Pipe	糸道パイプ	1
6	000340	Nut	ナット	1
7	2150303	Tension Disc Eyelet	二重環調子台糸道	1
8	006348	Tension Post	糸調子棒	1
9	0020124	Tension Disc	二重環糸調子皿	2
10	0020125	Double Chaining Looper Tension	二重環糸調子バネ	1
11	0020126	Tension Spring Bushing	二重環糸調子ナット回り止メ	1
12	000182	Adjusting Nut	調節ナット	1
13	000932	Rubber Cushion(Large)	埋メ座 (大)	1
14	2150314	Double Chaining Looper Eyelet	二又糸道	1
15	2150302	Chaining Looper Thread Eyelet(Left)	二重環ルーパ糸道 (左)	1
16	150005	Screw(M3-0.5×3)	詰ネジ	1
17	2160019	Needle Thread Pull-off	針糸繰り	1
18	2150313	Upper Knife Holder(Flat Type)	上メスホルダ (平)	1
19	0022963	Tape Guide Stay	テープガイド支エ	1
20	0022981	Tape Guide Stay Shaft	テープガイド支エ軸	1
21	110009	Screw(M4-0.7×8)	止ネジ	1
22	003638	Screw(11/64-40×4)	止ネジ	2
23	0022982	Tape Guide	テープガイド	1
25	2150310	Needle Thread Eyelet(Left)(Double Chain)	二重環針道(左)	1
24	110001	Screw(M4-0.7×8)	止ネジ	1
26	0030255	Tension Spring(Double Chain Thread)	針糸調子バネ(二重環)	2
27	2150312	Folder Bracket	定規取付台	1
28	110041	Screw(M4-0.7×8)	止ネジ	1
29	2150311	Folder	定規	1
30	000665	Washer	ワッシャ	1
31	110104	Screw(M4-0.7×8)	止ネジ	1

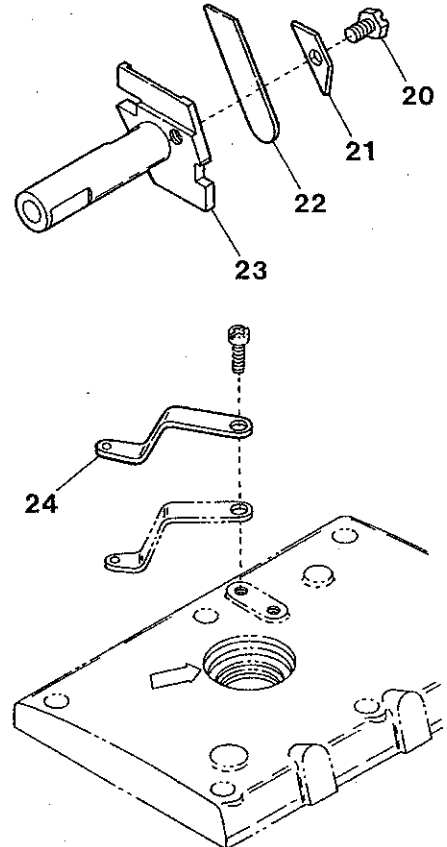
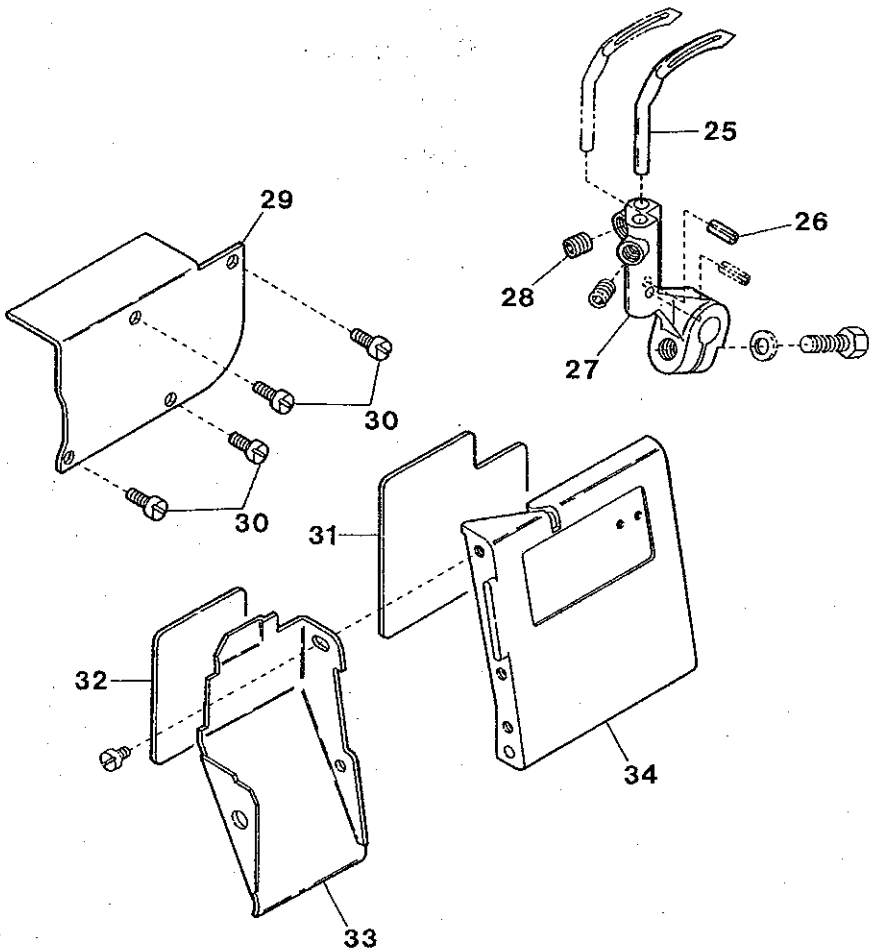
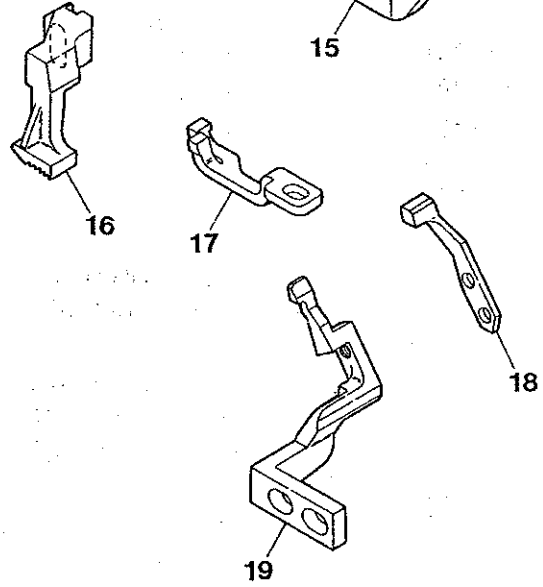
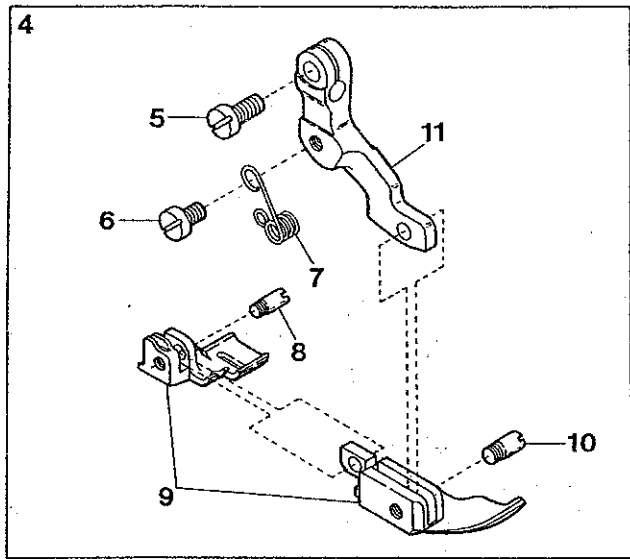
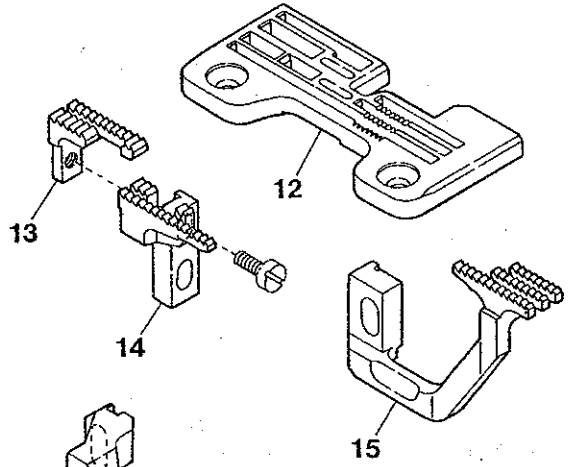
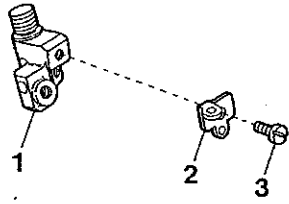

AZR8920G(2) EXCLUSIVE PARTS

サブクラス専用部品(2)

2

Ref. No.	Parts No.	Description	品名	Amt. Req.
1	2169114	Needle Clamp(C)	針止メ	1
2	2150300	Needle Clamp Eyelet	針止メ糸道	1
3	110122	Screw(M2-0.4×4)	止ネジ	1
4	2167000	Presser Foot C. Set(C)	押エ(組)	1
5	004351	Screw(9/64-40×7)	止ネジ	1
6	009730	Screw(1/8-44×5.3)	止ネジ	1
7	2127694	Presser Foot Spring	押エバネ	1
8	280004	Screw(3/32-56×2.4)	止ネジ	1
9	2167001	Presser Foot(Front/Rear)	押エ(前後)(組)	1
10	004136	Screw(1/8-44×2.7)	止ネジ	1
11	2167004	Presser Foot Hinge	押エヒンジ	1
12	2158001	Stitch Plate	針板	1
13	2159006	Auxiliary Feed Dog	小送り	1
14	2159004	Main Feed Dog	後送り	1
15	2159004	Differential Feed Dog	前送り	1
16	2169070	Top Feed Dog	上送り	1
17	2159203	Needle Guard(Front)	針受ケ(前)	1
18	2159201	Needle Guard(Right)(Rear)	針受ケ(右)(後)	1
19	2159202	Needle Guard(Left)(Rear)	針受ケ(左)(後)	1
20	140010	Screw(M4-0.7×6)	止ネジ	1
21	2121113	Lower Knife Clamp	下メス押エ	1
22	2121111	Lower Knife	下メス	1
23	2150305	Lower Knife Holder	下メス台	1
24	2120536	Double Chaining Looper Eyelet	二重環ルーパ補助糸道	1
25	2109302	Double Chaining Looper	二重環ルーパ	1
26	000035	Positioning Pin	位置決メピン	1
27	2150306	Double Chaining Looper Holder	二重環ルーパ台	1
28	160003	Screw(M5-0.8×3)	止ネジ	1
29	2150307	Looper Holder Cover	ルーパ台カバー	1
30	110009	screw(M4-0.7×8)	止ネジ	4
31	390672	Threading Chart	糸通シ図	1
32	390673	Threading Chart(Left)	糸通シ図(左)	1
33	2150308	Chip Guard (Openable)	切屑落シ板	1
34	2150309	Front Cover	前開キカバー	1