

NEEDLE COOLING MECHANISM COMPONENTS

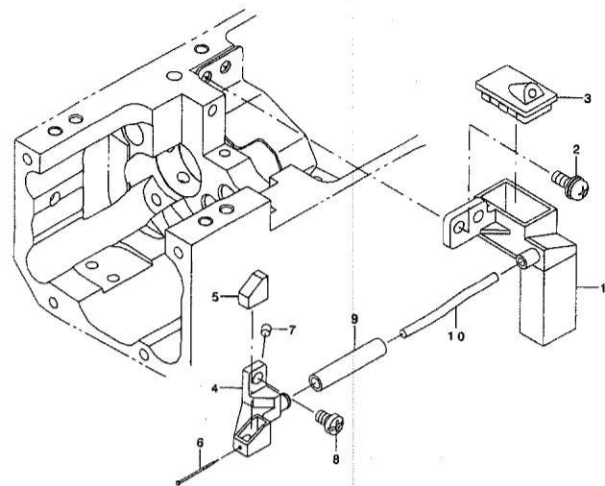

F.NO	NOTE	PART NO.	DESCRIPTION	Qty
1		134-29055	SILICONE OIL TANK ASSY	1
2		SL-4041081-SC	SCREW M4 L=10	2
3		134-29105	SILICONE OIL TANK CAP	1
4		134-29204	SILICONE OIL CUP	1
5		134-29303	FELT	1
6		118-56101	NEEDLE COOLER PIN	1
7		TA-0290301-M0	PLUG	1
8		SM-4040655-SP	SCREW M4 L=6	1
9		BT-0600402-EA	OIL TUBE	0.03
0		CQ-3030000-00	OIL WICK	0.1

17. ACCESSORIES PARTS COMPONENTS

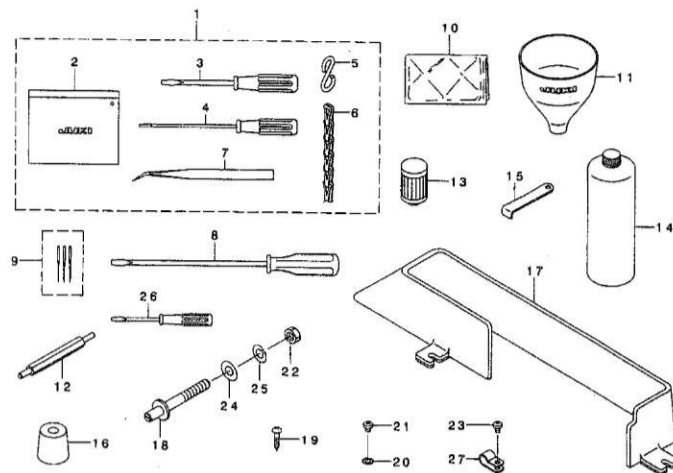

REF.NO	NOTE	PART NO.	DESCRIPTION	Qty
1		400-13913	ACCESSORY BAG ASSY	1
2		229-32800	ACCESSORIE BAG	(1)
3		229-33105	SCREW DRIVER, MIDDLE	(1)
4		123-47308	SCREW DRIVER (SHALL)	(1)
5		131-60304	S SHAPED HOOK	(2)
6		260-37903	CHAIN	(1)
7		122-88403	TWEEZERS	(1)
8		229-33006	SCREW DRIVER, LARGE	1
9		HUY-128S1003	NEEDLES (PACKAGE OF 3)	1
10		229-33303	VINYL COVER	1
11		131-60601	FUNNEL	1
12		133-08952	SYNCHRONIZER STUD ASSY	1
13		131-42500	CARTRIDGE FILTER	1
14		MML-018900CA	JUKI MACHINE OIL 18	1
15		BS101-490-000	DRIVER	1
16		131-55403	DUST-PROOF RUBBER	4
17		134-29709	BELT COVER	1
18		133-49600	PIN FOR RUBBER CUSHION	4
19		SK-3412001-SE	WOOD SCREW D=4.1 L=20	3
20		WT-0430002-KH	WASHER M4	1
21		SM-4040501-SH	SCREW M4X0.7 L=5	1
22		NM-6080003-SC	NUT M8	4
23		SM-4040655-SP	SCREW M4 L=6	1
24		WP-0851216-SC	WASHER 8.5X18.0X1.2	4
25		YS-0820002-KR	SPRING WASHER M8	4
26		229-33204	SCREW DRIVER, SMALL	1
27		HX-0015000-OC	CABLE CLIP	1