

**ILLUSTRATED PARTS MANUAL
ILLUSTRIERTES TEILEVERZEICHNIS**

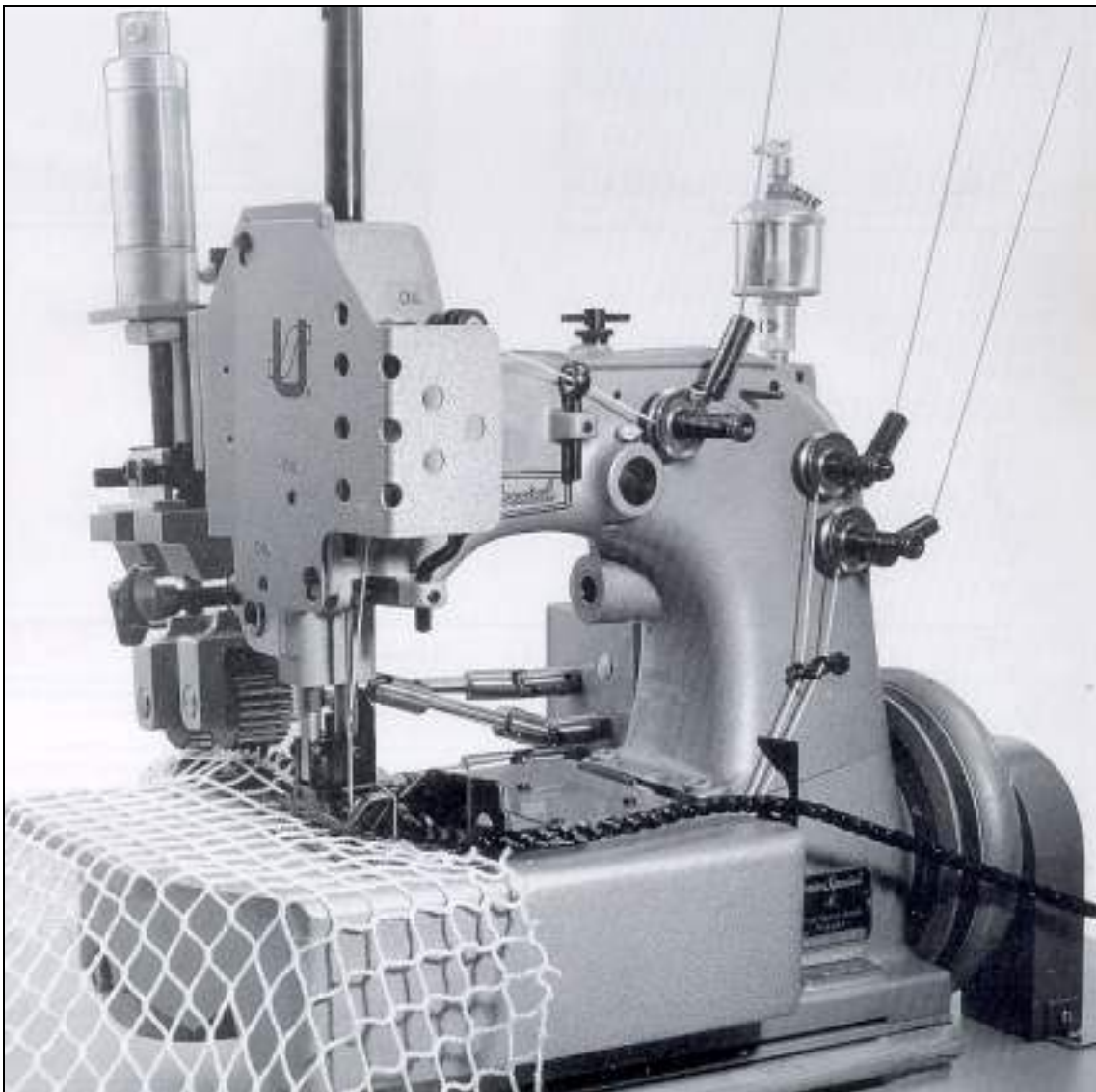

**MANUAL NO. / KATALOG NR. G234CZ
FOR STYLES / FÜR TYPEN
81500CZ3374A, 81500CZ3374B**

**SUPPLEMENT TO MANUAL NO. G234
ZUSATZ ZUM KATALOG NR. G234**

APPLICATION OF THIS MANUAL

This manual is a supplement to the manual No. G234 and should be used in conjunction therewith.

OBSERVE THE SAFETY RULES IN MANUAL NO. G234!



Only the parts found on Styles 81500CZ3374A and 81500CZ3374B are illustrated which are different from those of Style 81500C. INSTALLATION, LUBRICATION, NEEDLES, OPERATING INSTRUCTIONS, MAINTENANCE and INSTRUCTIONS FOR MECHANICS are the same as described in manual No. G234 for Style 81500C.

HINWEISE FÜR DIE BENÜTZUNG DIESES KATALOGS

Dieser Katalog ist ein Zusatz zum Katalog Nr. G234 und muß in Verbindung mit diesem verwendet werden.



BEACHTEN SIE DIE SICHERHEITSHINWEISE IM KATALOG NR. G234!

Es sind nur die Teile für die Maschinen 85100CZ3374A und 81500CZ3374B abgebildet, die sich von denen für die Maschinen 81500C unterscheiden. AUFSTELLUNG, ÖLEN, NADELN, BEDIENUNGSANLEITUNG, WARTUNG und MECHANIKERANLEITUNG sind gleich wie im Katalog Nr. G234 für die Maschine 81500C beschrieben.

Subject to change without notice / Änderungen vorbehalten

G234CZ 06-03
Printed in Germany
All rights reserved

1st Edition / 1. Ausgabe
© Union Special GmbH 2003
Alle Rechte vorbehalten

IDENTIFICATION OF MACHINES

Each UNION SPECIAL 81500 series machine is identified by a style number, which is stamped on the style plate affixed to the right front of machine. Serial number is stamped into bed casting at the right front base of machine.

STYLES OF MACHINE

81500CZ3374A: Single Needle, Three Thread Overedging Sewing Machine for attaching ropes from 5/64 inch to 19/32 inch (2 - 10 mm) - depending on the thickness of the net and size of knots - as border or tensioning rope to nets used for sports, protection or safety.

Maximum Speed: 1200 stitches / min.,
depending on fabric and
sewing operation

Recommended operating speed: 950 stitches / min.

Stitch Range: 2 - 5 SPI (4 - 12 mm)

Standard Setting: 2.5 SPI (10 mm)

Sewing Capacity: 3/64 - 5/8 inch (2 - 16 mm)

Standard Needle: 9853GA300/120

Needle Stroke: 2 51/64 inch (71 mm)

Handwheel pitch dia = 5 27/32 inch (150 mm)

Needle Thread: Net Yarn 210/24 or 210/3

PP Yarn, 4000 Denier

Looper Thread: Net Yarn 210/24 or 210/30

PP Yarn, 4000 Denier

Feed: Intermittend stepper twin puller,
two driven upper and one driven lower roller. Roller
pitch 5 mm.

Required Installation: UN280G132

Sewing table with clutch motor
Motor pulley pitch dia = 3 15/16 inch (100 mm)

For nets sewn parallel to the meshes, no feed dog is used and the throat plate has no slots (Standard version).

For nets sewn diagonal to the meshes a feed dog with matching throat plate is included.

Max. SPI 2.5 (10 mm).

For joining nets larger than 45 mm mesh width.

81500CZ3374B: Same as 81500CZ3374A but for attaching ropes from 25/64 inch to 5/8 inch (10 - 16 mm) - depending on the thickness of the net and size of knots.

Performance tests necessary for both machines.

BEZEICHNUNG DER MASCHINEN

Jede UNION SPECIAL 81500 Maschine hat eine in das Typenschild eingeprägte Typennummer, das rechts vorne am Gehäuse befestigt ist. Die Seriennummer ist in das Gußgehäuse rechts vorne im Sockel der Maschine eingepägt.

MASCHINENTYPEN

81500CZ3374A: Einnadel-Dreifaden-Überwendlich-Nähmaschine zum Annähen von Seilen mit einem Durchmesser von 2 bis 10 mm (abhängig von Netzdicke und Größe der Knoten) als Randabschluß oder als Spannsell an Netze, besonders an Sport-, Schutz- und Sicherheitsnetzen.

Maximale Drehzahl: 1200 Stiche / min.,
je nach Material und
Nähoperation

Empfohlene Betriebsdrehzahl: 950 Stiche / min.

Stichlänge: 4 - 12 mm

Standardstichlänge: 10 mm

Nähgutdurchgang: 2 - 16 mm

Standardnadel: 9853GA300/120

Nadelhub: 71 mm

Handrad-Durchmesser = 150 mm

Nadelfaden: Netzgarn 210/24 oder 210/30

PP-Garn, 4000 Denier

Greiferfaden: Netzgarn 210/24 oder 210/30

PP-Garn, 4000 Denier

Transport: Intermittierender Schritt-Doppel-
puller, zwei obere und eine untere Rolle angetrieben,
Rollenzahlteilung 5 mm.

Erforderlicher Arbeitsplatz: UN280G132

Nähtisch mit Kupplungsmotor
Motor-Scheibendurchmesser = 100 mm

Für Netze, an denen parallel zu den Maschen genäht wird, wird in der Nähmaschine kein Transporteur verwendet; die Stichplatte ist ohne Transporteurschlitz (Standardausführung). Für Netze, an denen diagonal zu den Maschen genäht wird, wird ein Transporteur mit passender Stichplatte verwendet (beigepackt), Stichlänge max. 10 mm.

Zum Zusammennähen von Netzen ab 45 mm Maschenweite.

81500CZ3374B: Wie 81500CZ3374A, jedoch zum Annähen von Seilen von 10 - 16 mm, abhängig von Netzdicke und Größe der Knoten.

Nähversuche für beide Maschinen erforderlich.

Stitch Type / Seam Type

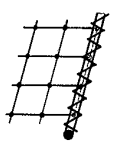

Net parallel
to rope

Stitch Type 504
Seam Type EFD-1

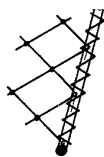

Net diagonal
to rope

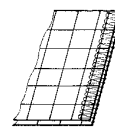
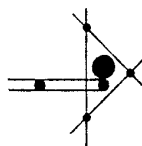

Nets joined
parallel

Stitch Type 504
Seam Type SSa-1

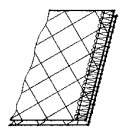

Nets joined
diagonal

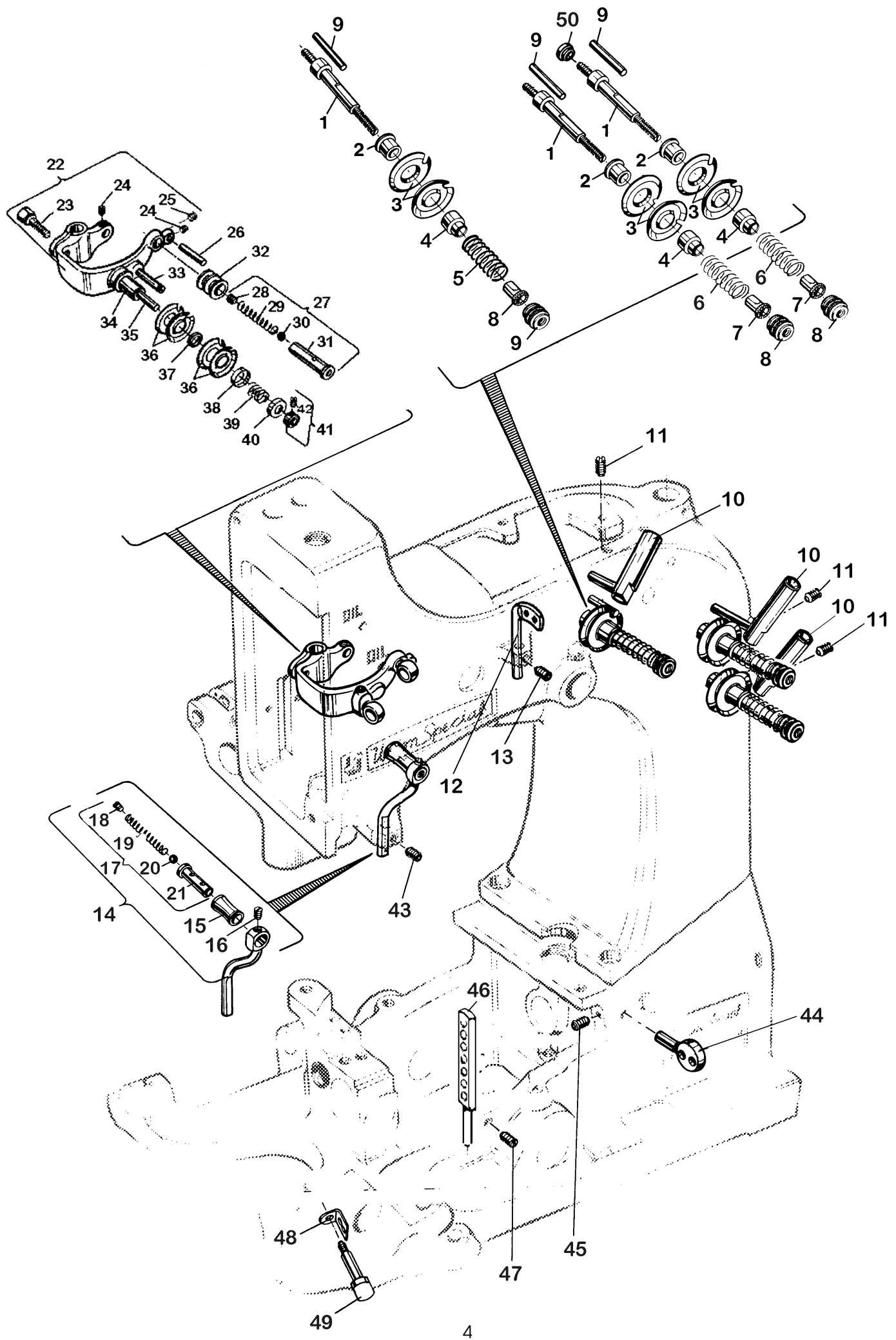

THREAD TENSION AND GUIDE PARTS
FADENSPANNUNGEN UND FADENFÜHRUNGSTEILE

<u>Ref. No.</u> <u>Pos. No.</u>	<u>Part No.</u> <u>Teil Nr.</u>	<u>Description</u>	<u>Beschreibung</u>	<u>Amt. Req.</u> <u>Anzahl</u>
1	HS106	Tension Post	Spannungsbolzen	3
2	80669B	Tension Post Ferrule	Hülse für Spannungsbolzen	3
3	80676A	Tension Disc	Spannungsscheibe	6
4	HA1349	Tension Sleeve	Federhülse	3
5	HS110A	Spring for Needle Thread Tension	Feder für Nadelfadenspannung	1
6	110-2	Spring for Looper Thread Tension	Feder für Greiferfadenspannung	2
7	107	Tension Spring Ferrule	Spannungsfeder-Hülse	3
8	108	Tension Nut	Spannungsmutter	3
9	80667	Pin for Tension Discs	Stift für Spannungsscheiben	3
10	81256A	Thread Sleeve	Fadenhülse	3
11	22560B	Set Screw	Gewindestift	3
12	80858AX	Needle Thread Guide	Nadelfadenführung	1
13	22894AD	Set Screw	Gewindestift	1
14	80665D	Needle Thread Take-up Roller Assm.	Nadelfadenabzugsrolle, komplett	1
15	80668	Take-up Roller	Abzugsrolle	1
16	88	Set Screw	Gewindestift	1
17	HS53B	Roller Stud Assembly	Rollenbolzen, komplett	1
18	22560	Set Screw	Gewindestift	1
19	HA1286B	Spring	Feder	1
20	12964C	Spring Ball	Federkugel	1
21	81086G	Roller Stud	Rollenbolzen	1
22	80759	Needle Bar Connection	Nadelstangenmitnehmer	1
23	BP108	Hex. Head Cap Screw	Sechskantschraube	1
24	22894AY	Set Screw	Gewindestift	2
25	22894W	Set Screw	Gewindestift	1
26	80655D	Thread Guide Pin	Fadenführungsstift	1
27	HS52B	Roller Stud Assembly	Rollenbolzen komplett	1
28	22560	Set Screw	Gewindestift	1
29	HA1286B	Spring	Feder	1
30	12964C	Spring Ball	Federkugel	1
31	81086C	Roller Stud	Rollenbolzen	1
32	81293	Thread Guide Roller	Fadenführungsrolle	1
33	92132	Shank Screw	Zapfenschraube	1
34	80669A	Tension Post Ferrule	Hülse für Spannungsbolzen	1
35	81246	Tension Post	Spannungsbolzen	1
36	80676	Tension Disc	Spannungsscheibe	4
37	81294	Spacer Ring	Distanzring	1
38	HA58C	Spring Ferrule	Federhülse	1
39	HA58F	Spring	Feder	1
40	HA58D	Spring Ferrule	Federhülse	1
41	21111	Collar	Stelling	1
42	22743	Set Screw	Gewindestift	1
43	22894AD	Set Screw	Gewindestift	1
44	81254A	Eyelet for looper threads	Fadenführung für Greiferfäden	1
45	22894AD	Set Screw	Gewindestift	1
46	81287A	Looper Thread Guide	Greiferfadenführung	1
47	88	Set Screw	Gewindestift	1
48	81350D	Looper Thread Guide	Greiferfadenführung	1
49	80696A	Stud	Bolzen	1
50	99623A	Spacer for lower looper thread tension post	Distanzbuchse für unteren Greiferfaden-Spannungsbolzen	1

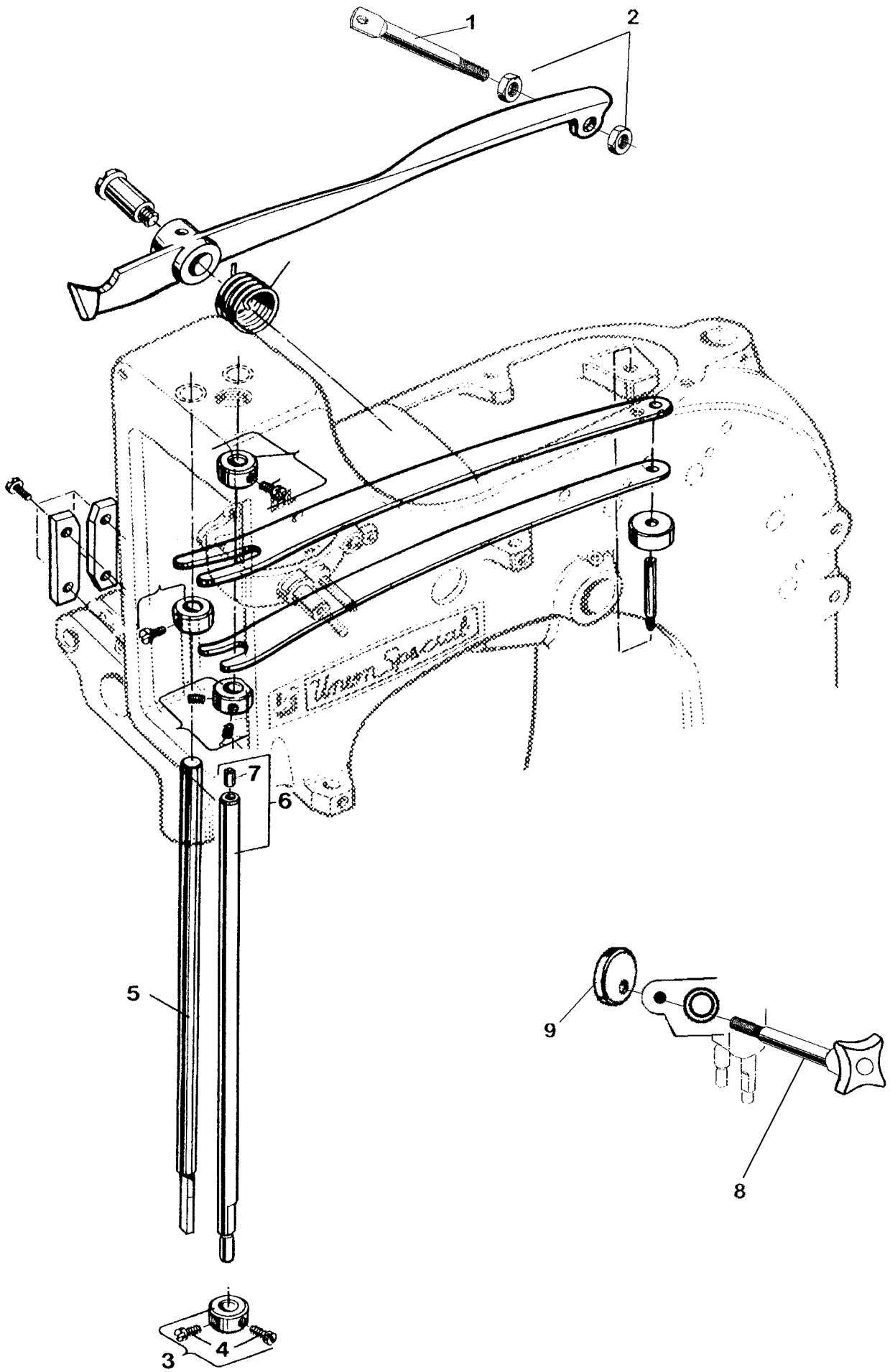

PRESSER BARS AND PRESSERFOOT LIFTER
DRÜCKERFUßSTANGEN UND DRÜCKFUßLIFTERHEBEL

<u>Ref. No.</u> <u>Pos. No.</u>	<u>Part No.</u> <u>Teil Nr.</u>	<u>Description</u>	<u>Beschreibung</u>	<u>Amt. Req.</u> <u>Anzahl</u>
1	35780B	Lifter Lever Extension	Lifterverlängerung	1
2	258	Nut	Mutter	2
3	81566	Collar	Stellring	1
4	22836	Screw	Schraube	2
5	80760A	Presser Bar, left	Drückerfußstange, links	1
6	80661B	Presser Bar, right	Drückerfußstange, rechts	1
7	CO67D	Cork Plug	Korkstopfen	1
8	81567B	Eccentric Disc	Exzentrerscheibe	1
9	81567A	Handle Screw	Griffschraube	1

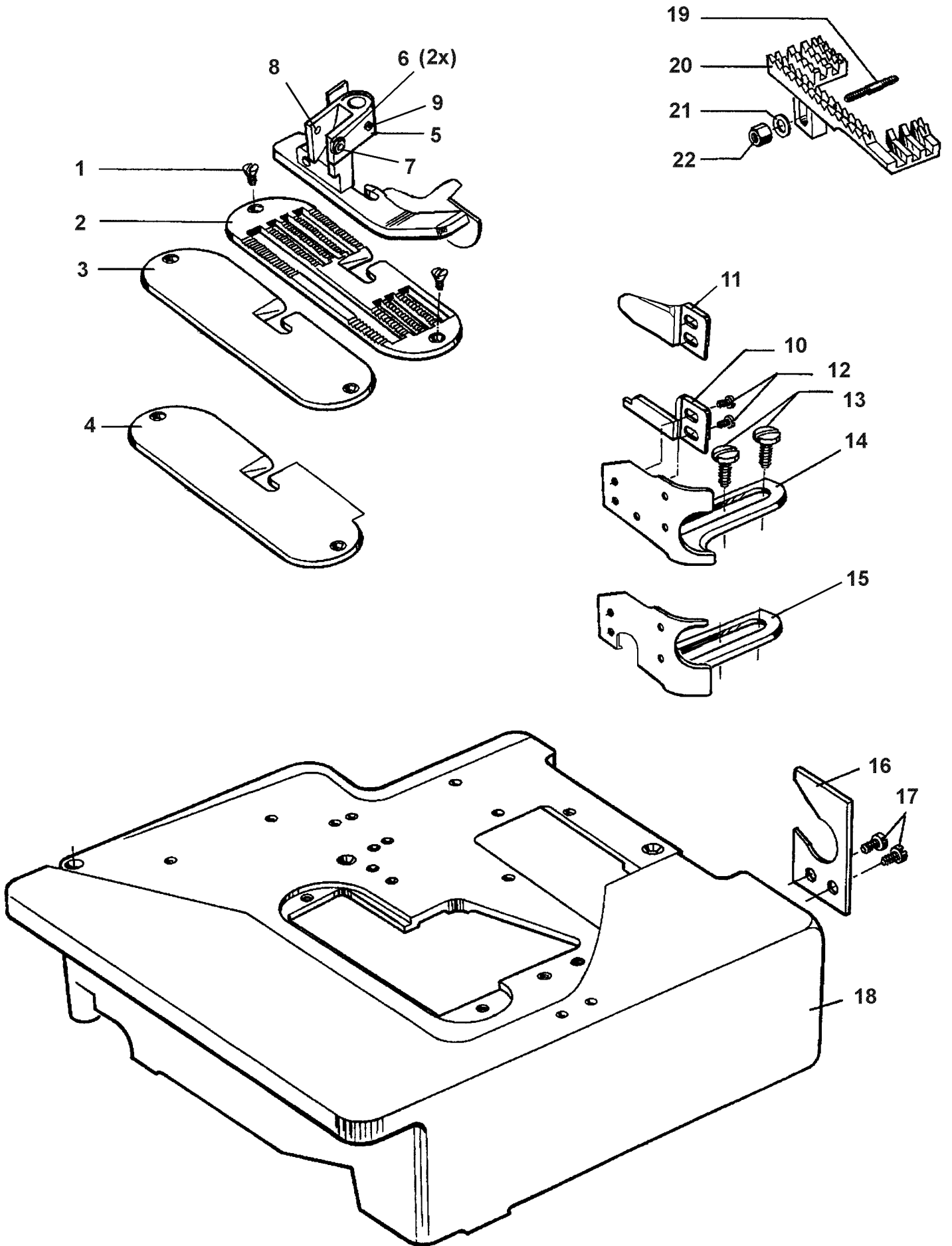

SEWING PARTS AND CLOTH PLATE
NÄHTEILE UND STOFFPLATTE

<u>Ref. No.</u> <u>Pos. No.</u>	<u>Part No.</u> <u>Teil Nr.</u>	<u>Description</u>	<u>Beschreibung</u>	<u>Amt. Req.</u> <u>Anzahl</u>
1	78057	Screw	Linsensenkschraube	2
2	81524B	Throat Plate	Stichplatte	1
3	81524L	Throat Plate for 3374A	Stichplatte ohne Transportschlitz für 3374A	1
4	81524LA	Throat Plate for 3374B	Stichplatte ohne Transportschlitz für 3374B	1
5	81520LA	Presser Foot	Drückerfuß	1
6	12934A	Nut	Sechskantmutter	2
7	89	Screw	Gewindestift J2x4,8	1
8	22560A	Screw	Gewindestift J2x8,7	1
9	22894AD	Screw	Gewindestift Q2x6,4	1
10	81503M	Cloth Guide Tongue for 3374A	Stoffführungszunge für 3374A	1
11	81503MA	Cloth Guide Tongue for 3374B	Stoffführungszunge für 3374B	1
12	HS24C	Screw	Zylinderschraube	2
13	22514	Screw	Zylinderschraube	2
14	81303FL	Edge Guide for 3374A	Stoffkantenführung für 3374A	1
15	81303FLA	Edge Guide for 3374B	Stoffkantenführung für 3374B	1
16	81503N	Rope Guide	Seilführung	1
17	94	Screw	Zylinderschraube	2
18	81501LP	Cloth Plate	Stoffplatte	1
19	22686C	Screw	Gewindestif, Innensechskant	1
20	81505L	Feed Dog	Transporteur	1
21	69H	Washer	Unterlagscheibe	1
22	51487	Nut	Sechskantmutter	1



STEPPER TWIN PULLER
SCHRITT-DOPPELPULLER



STEPPER TWIN PULLER
SCHRITT-DOPPELPULLER

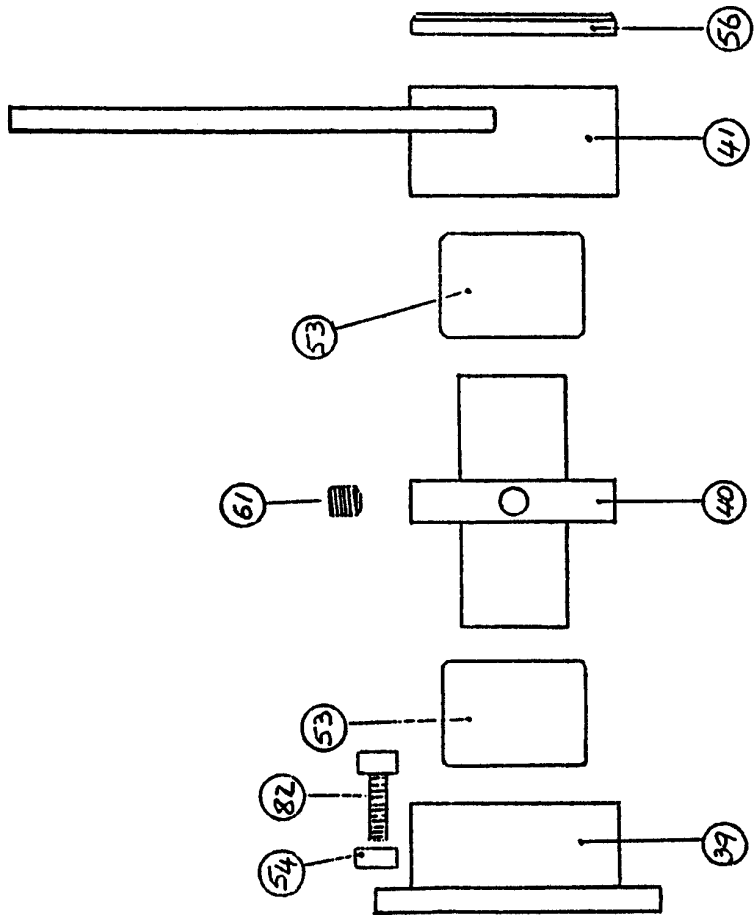
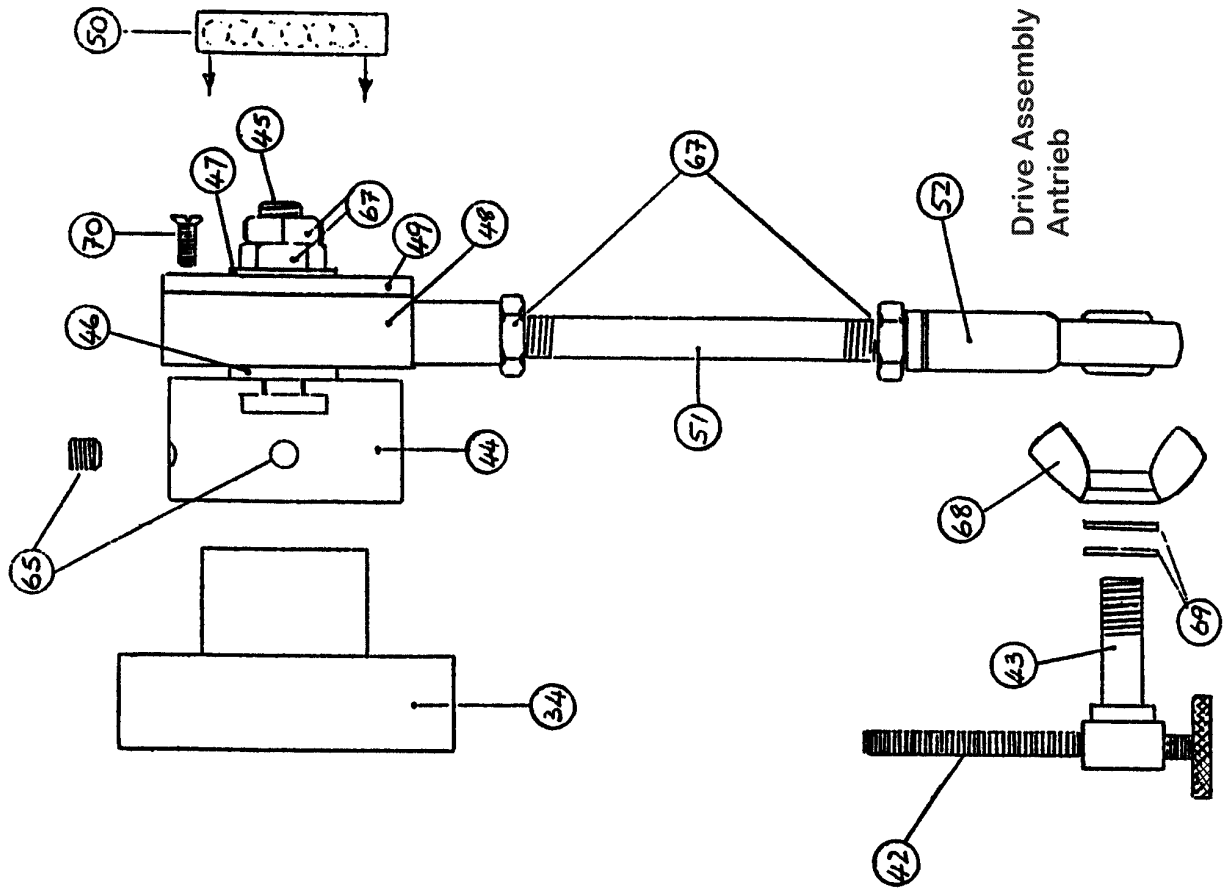

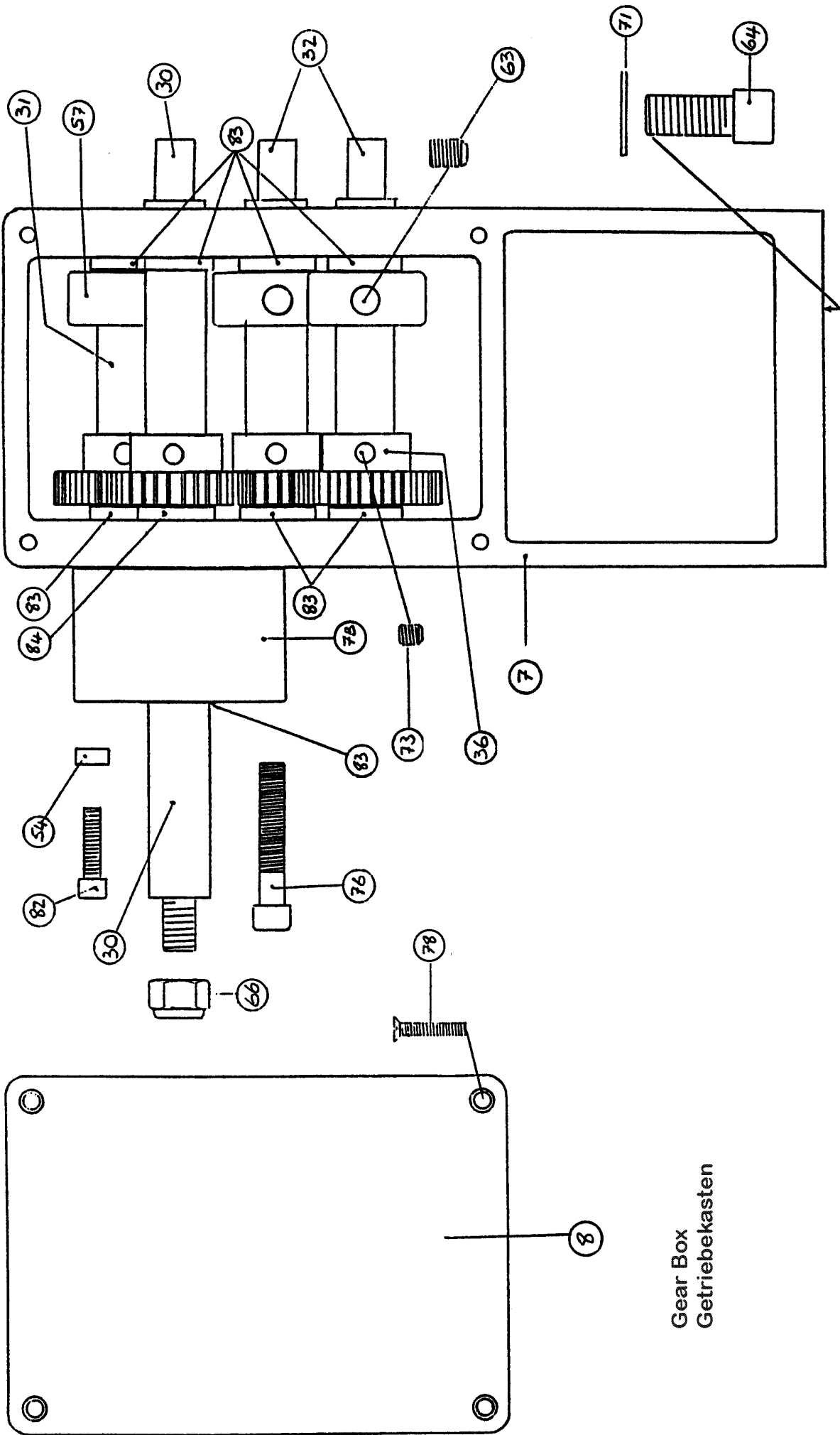

Gear Box
Getriebekasten

Roller Lifter
Rollenlifter

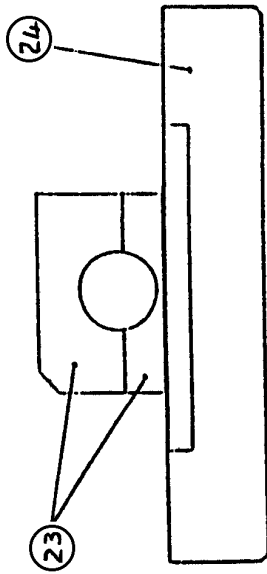

Top Roller Assembly
Obere Rolle komplett

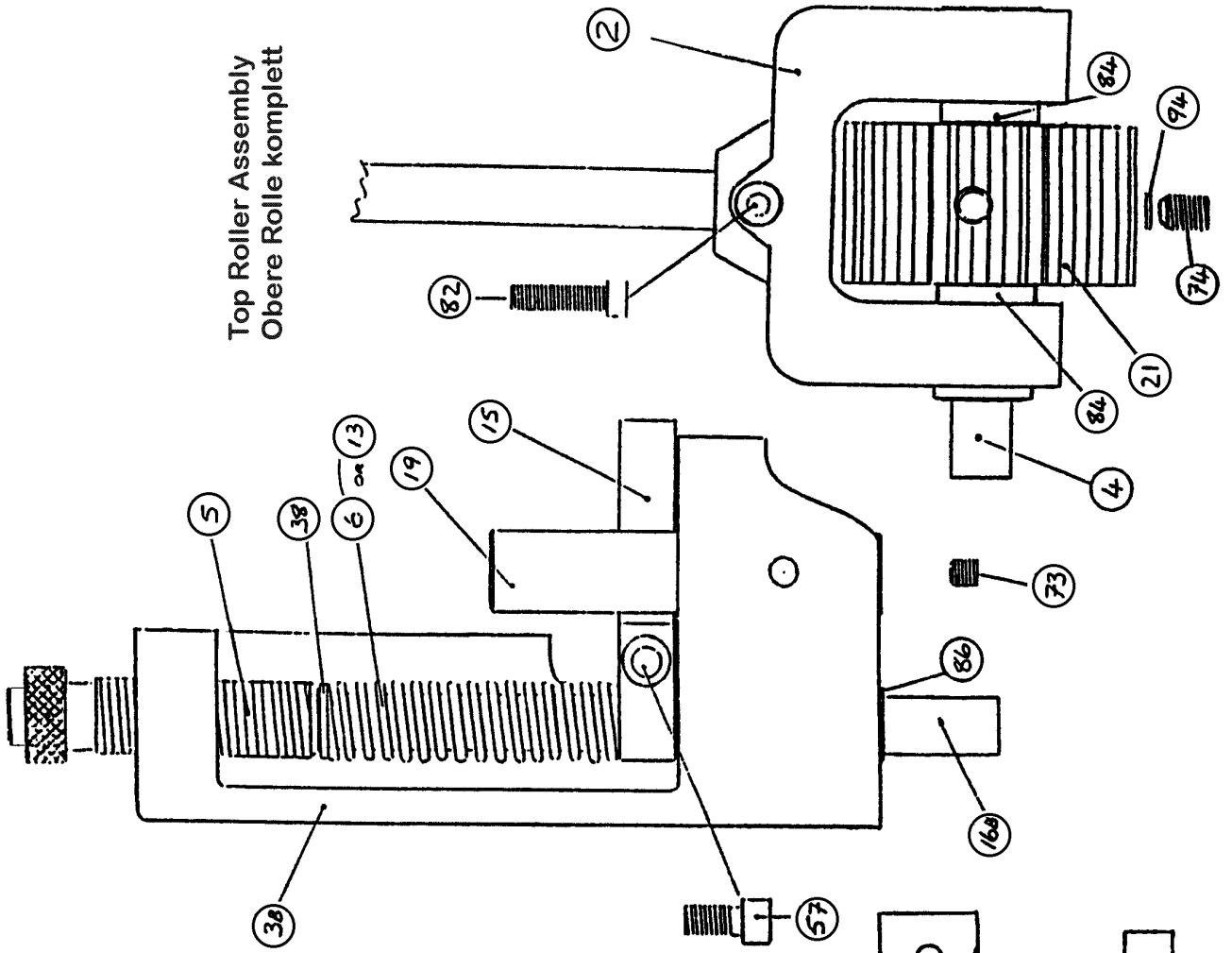

Drive Shaft
Antriebswelle

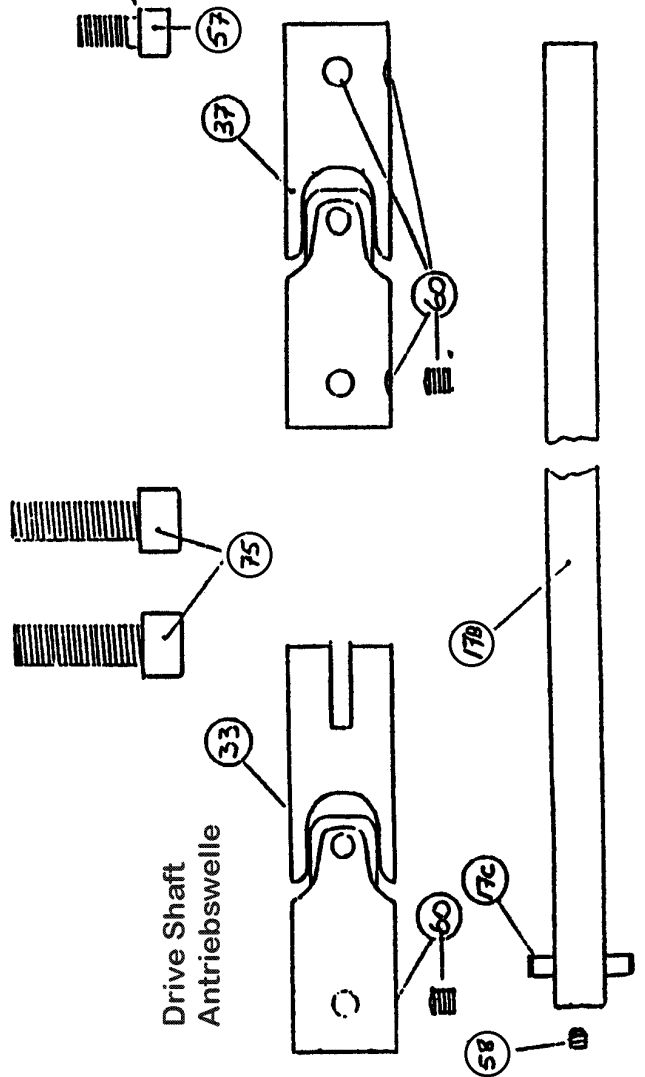

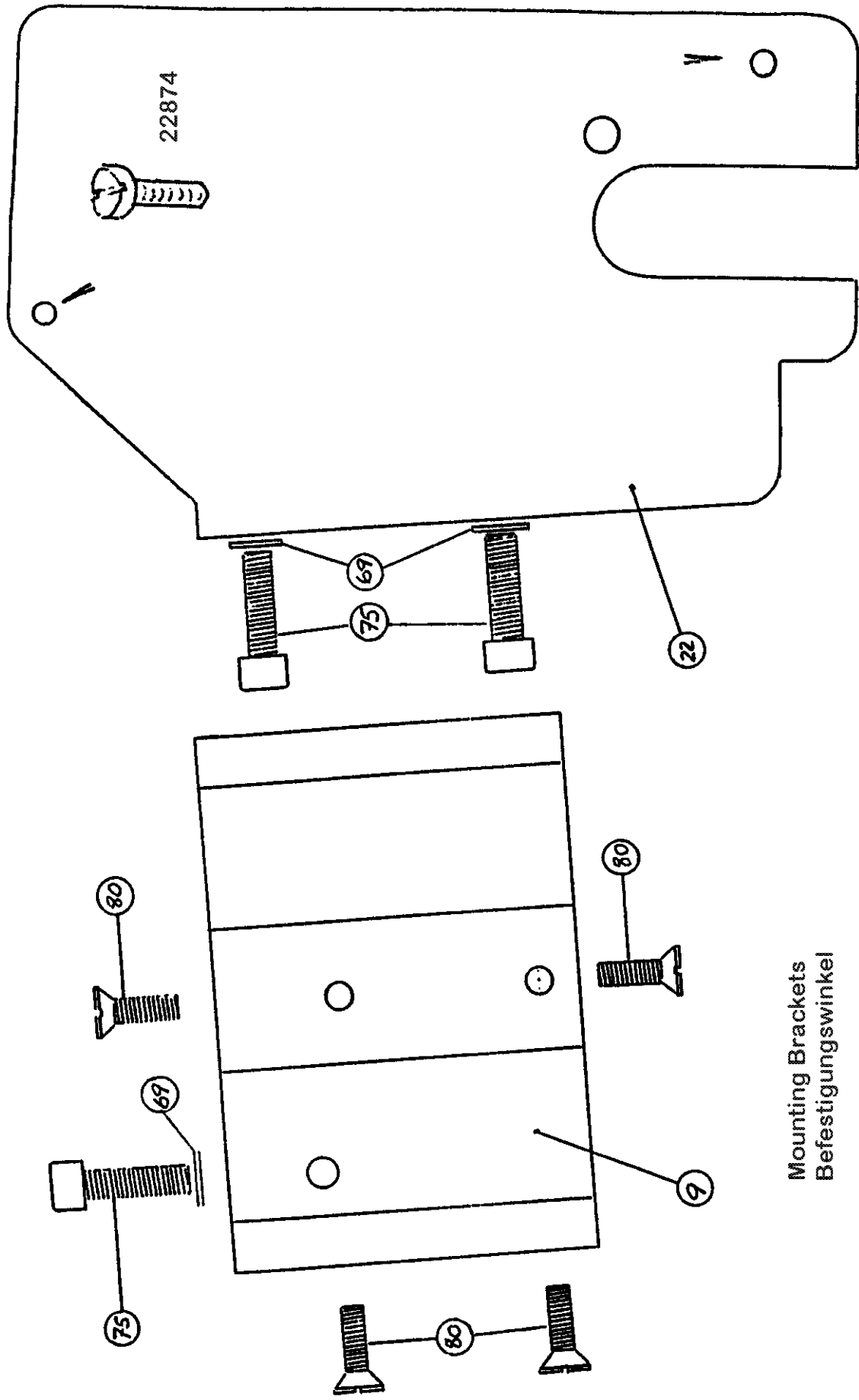

Mounting Brackets
Befestigungswinkel

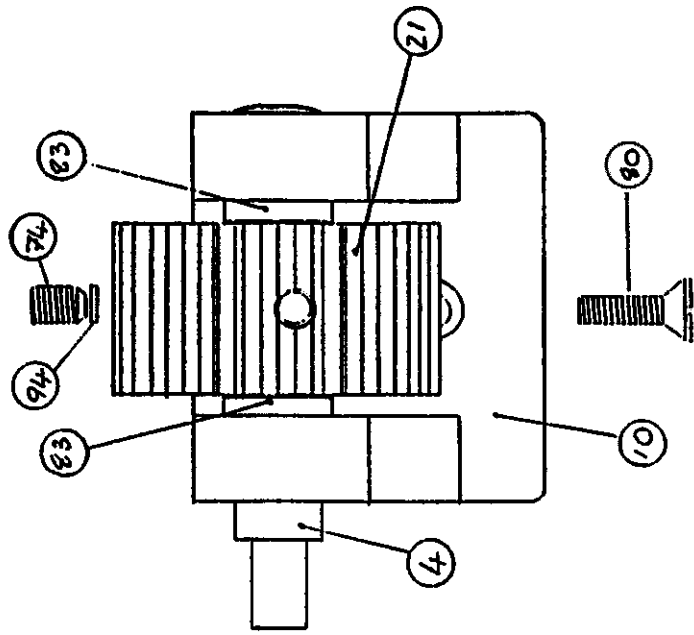

Rear
Hinten

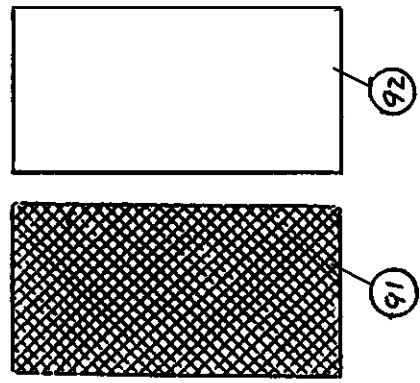

Knurled Roller Polypropylene
geraadete Roller
Rolle Kunststoffrolle

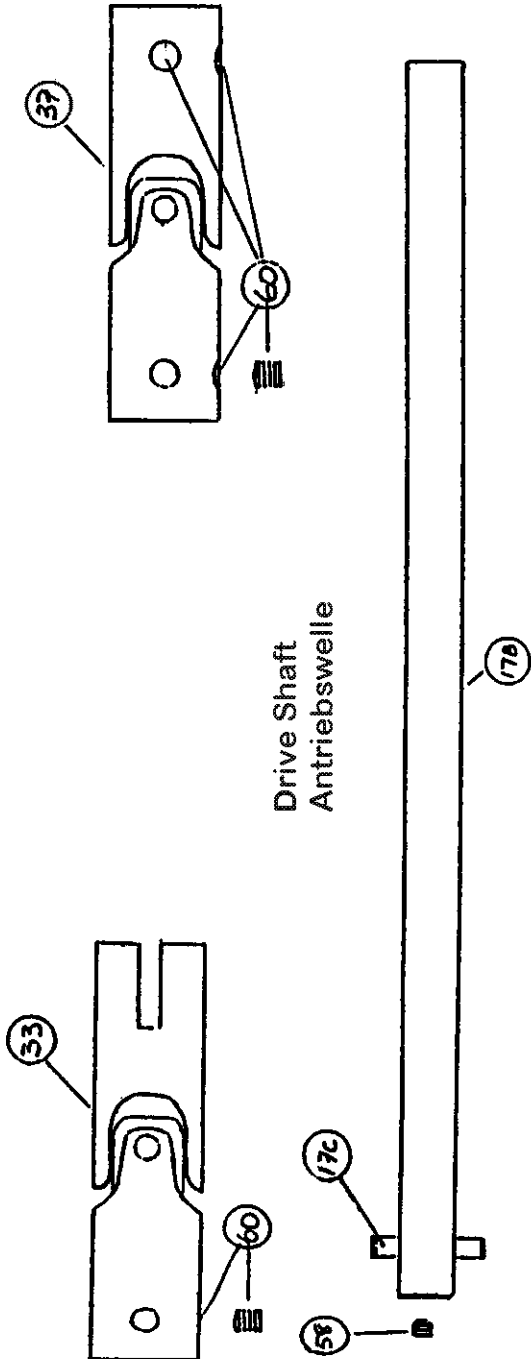

Drive Shaft
Antriebswelle

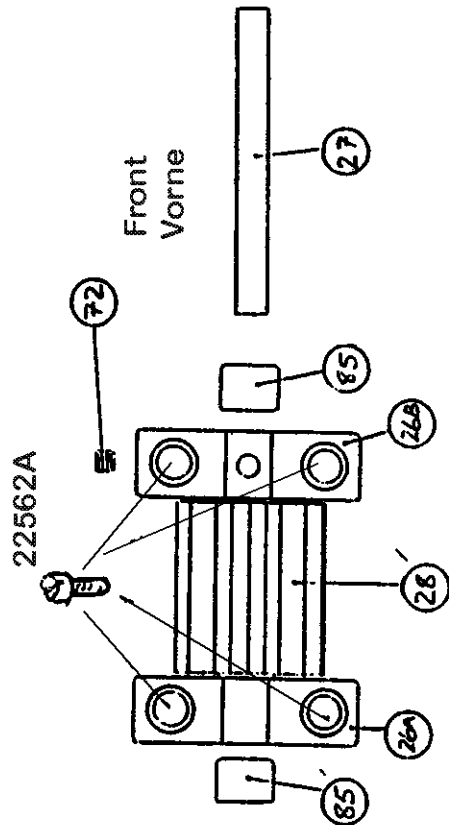

Front
Vorne

Bottom Roller Assembly
Untere Rolle komplett

Air Cylinder Bracket
Halter fuer Luftzylinder

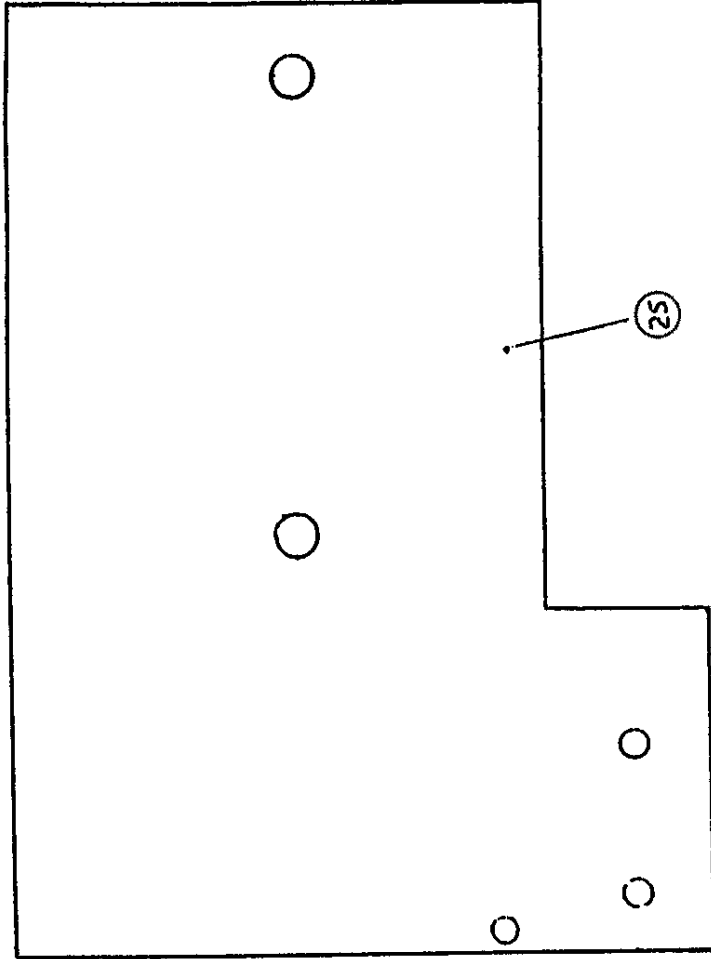
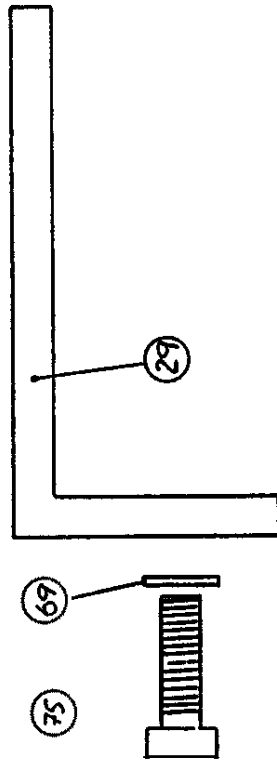

Base Plate
Grundplatte

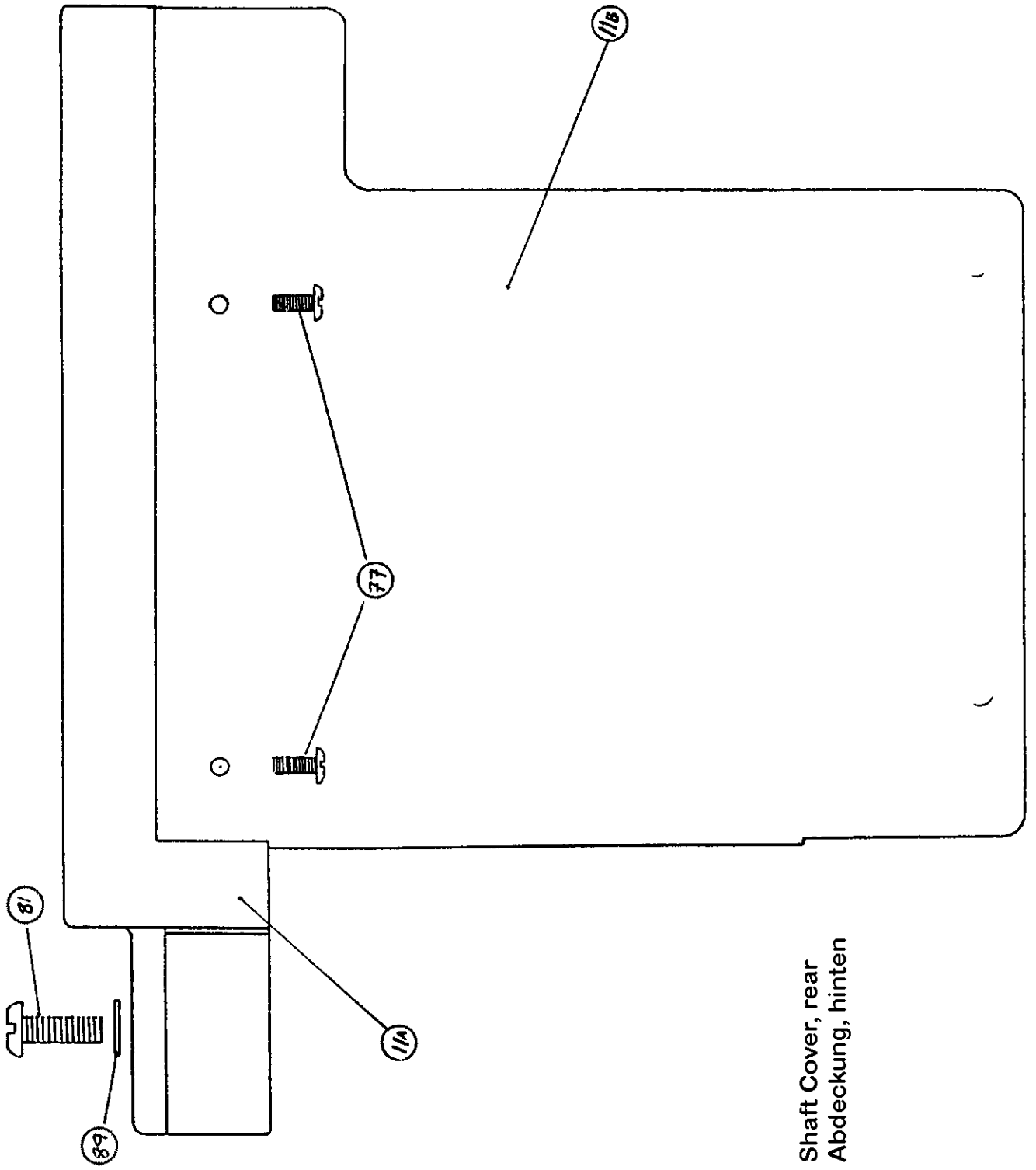

Shaft Cover, rear
Abdeckung, hinten

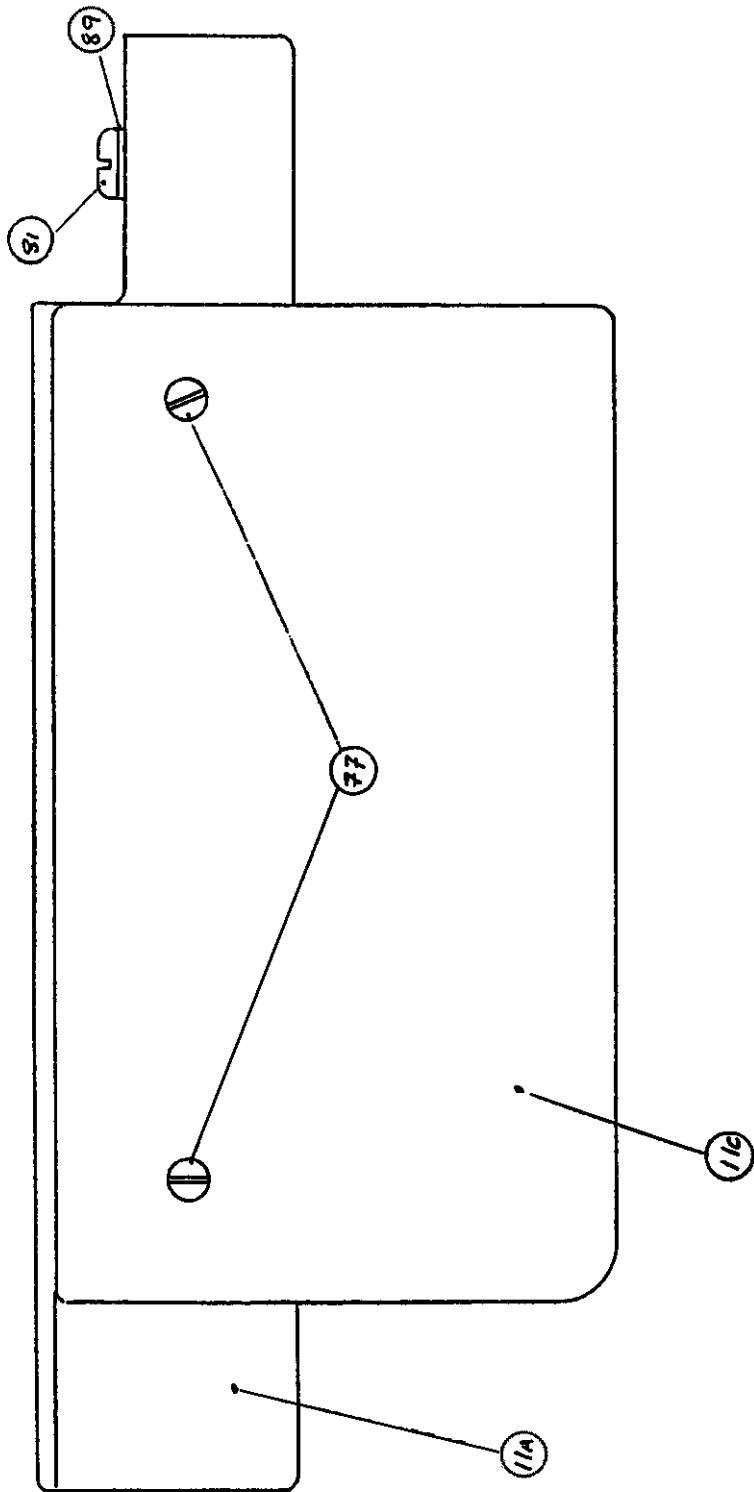

Shaft Cover, front
Abdeckung, vorn

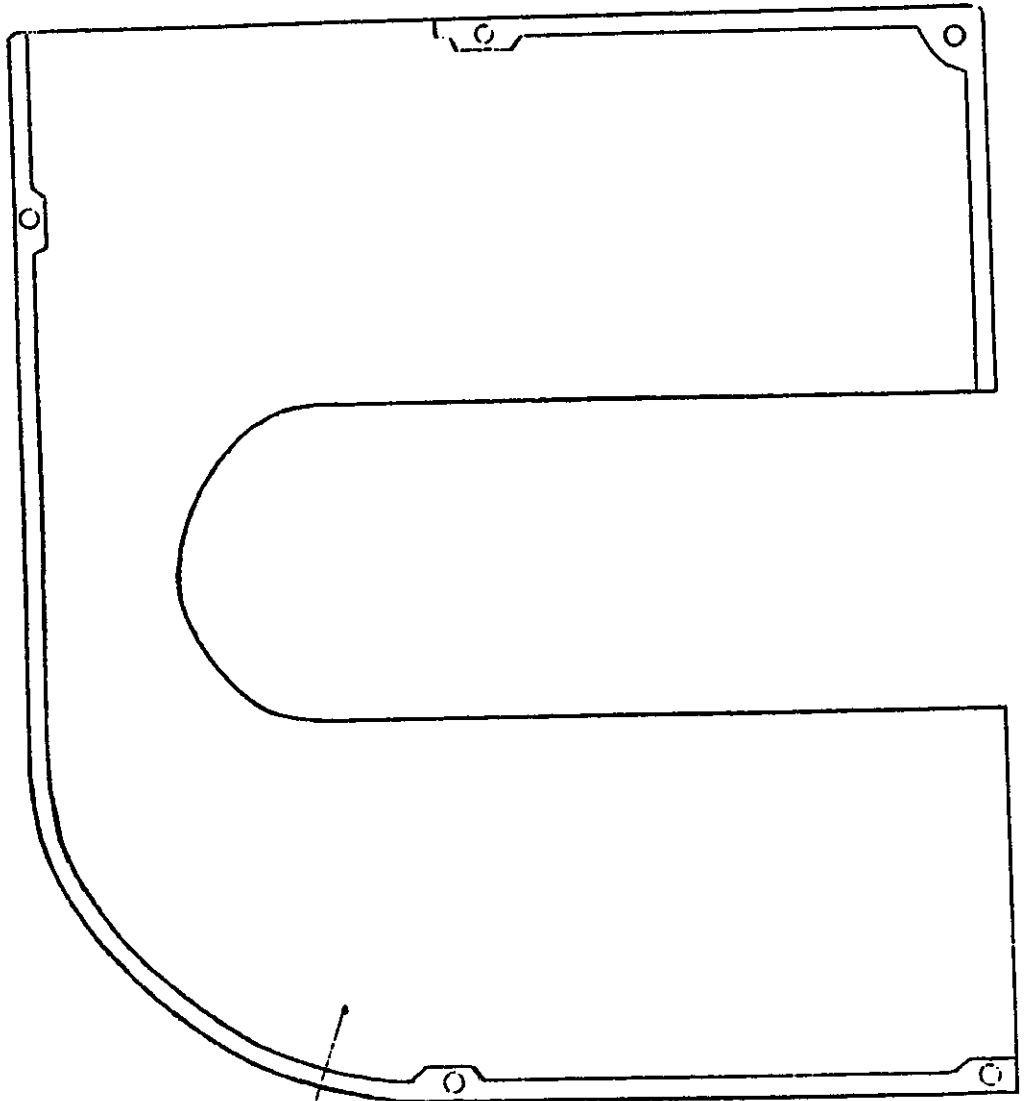

12A

Belt Cover
Riemenabdeckung

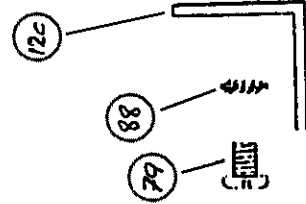

<u>Ref. No.</u> <u>Pos. No.</u>	<u>Part No.</u> <u>Teil Nr.</u>	<u>Description</u>	<u>Beschreibung</u>	<u>Amt. Req.</u> <u>Anzahl</u>
1	99706A	Stepper Twin Puller Assembly	Schritt-Doppelpuller komplett	1
	999-126	Coupling	Schraubanschlußstück	1
	999-127	Corner Connection	Eckanschlußstück	1
	999-234B	Air Cylinder	Einfach wirkender Zylinder	1
	G29912	Knee Pressure Valve	Pneumatikventil für Kniebetätigung	1
	99683M	Filter Regulator	Filterdruckminderer	1
	22874	Screw for stepper twin puller and face cover	Schraube für Schritt-Doppelpuller und Stirndeckel	2
	22562A	Screw for front lower roller	Schraube für vordere, untere Rolle	4
	99706	Stepper Twin Puller	Schrittpuller	1
2	99706-2	Roller Yoke	Joch für Rolle	2
3B	99706-3B	Main Roller Bracket	Haltewinkel	2
4	99706-4	Roller Shaft	Welle für Rolle	3
5	99706-5	Roller Pressure Screw	Druckschraube	2
6	99706-6	Roller Pressure Spring (standard)	Druckfeder	1
7	99706-7	Gearbox	Getriebekasten	1
7B	99706-7B	Gearbox Clutch Mounting Block	Lager für die Kupplung	1
8	99706-8	Gearbox Cover	Abdeckung für Getriebekasten	1
9	99706-9	Roller Units Mounting Block	Träger	1
10	99706-10	Bottom Roller Housing (rear)	Gehäuse für Rolle hinten	1
11A	99706-11A	Shaft Cover (rear)	Abdeckung hinten	1
11B	99706-11B	Shaft Cover (rear)	Abdeckung hinten	1
11C	99706-11C	Shaft Cover(front)	Abdeckung vorn	1
12A	99706-12A	Belt Cover	Riemenabdeckung	1
12B	99706-12B	---	---	-
12C	99706-12C	Bracket for Cover	Winkel für Abdeckung	1
13	99706-13	Roller Pressure Spring (heavy)	Druckfeder	1
14	99706-14	---	---	-
15	99706-15	Yoke Shaft Clamp	Pullerstangemitnehmer	2
16B	99706-16	Yoke Shaft	Pullerstange	2
17B	99706-17B	Drive Shaft	Welle	3
17C	99706-17C	Pin	Stift	3
18	99706-18	---	---	-
19	99706-19	Lever Support	Träger	2
20	99706-20	---	---	-
21	99706-21	Crimping Roller	Rolle	3
22	99706-22	Face Plate Mounting Bracket	Befestigungswinkel	1
23	99706-23	Lifter Clamp	Pratze	1
24	99706-24	Roller Lifter	Rollenlifter	1
25	99706-25	Base Plate	Grundplatte	1
26A	99706-26A	Bottom Roller Bearers (front)	Halter für Rolle vorn	1
26B	99706-26B	Bottom Roller Bearers (front)	Halter für Rolle vorn	1
27	99706-27	Bottom Roller Shaft (front)	Achse	1
28	99706-28	Bottom Crimping Roller (front)	Rolle	1
29	99706-29	Air Cylinder Bracket	Halter für Luftzylinder	1
30	99706-30	Clutch Shaft	Welle	1
31	99706-31	Jockey Gear Shaft	Getriebewelle	1
32	99706-32	Gear Shaft	Getriebewelle	2
33	99706-33	Universal Coupling (slotted)	Gelenk	3
34	99706-34	Pulley Adapter	Adapter für Handrad	1
35	99706-35	---	---	-
36	99706-36	Gear 32 DP 40 theeth	Zahnrad	4
37	99706-37	Universal Coupling	Gelenk	3
38	99706-38	Spring Head Washer	Federscheibe	2
39	99706-39	Clutch Flange End	Kupplungsflansch	1
40	99706-40	Clutch Center	Aufnahme für Kupplungslager	1
41	99706-41	Clutch Lever End	Kupplungshebel	1
42	99706-42	Clutch Vernier Adjusting Screw	Stellschraube	1
43	99706-43	Clutch Vernier Slide Bolt	Bolzen	1
44	99706-44	Handwheel Real Spigot Sleeve	Muffe für Handradadapter	1
45	99706-45	T Bolt	T-Bolzen	1
**46	99706-46	Ballrace Rod End Enter Bushing	Buchse	1
47	99706-47	Ballrace Rod End Retaining Washer	Sicherungsscheibe	1
**48	99706-48	Ballrace Rod End Body	Kugellagergehäuse	1
**49	99706-49	Ballrace Rod End Cover	Abdeckung für Kugellagergehäuse	1
**50	99706-50	Ballrace (EE4)	Kugellager	1

<u>Ref. No.</u> <u>Pos. No.</u>	<u>Part No.</u> <u>Teil Nr.</u>	<u>Description</u>	<u>Beschreibung</u>	<u>Amt. Req.</u> <u>Anzahl</u>
51	99706-51	Connecting Rod	Verbindungsstange	1
52	99706-52	Ball End (RF4)	Verbindung	1
53	99706-53	Needle Roller Clutch (RC10141FS)	Nadellager	2
54	99706-54	Clutch Anti Rotation Stop	Anschlag	1
55	99706-55	---	---	-
56	99706-56	Clutch Washer	Scheibe	1
57	99706-57	2BA x 3/8 inch Socket Cap Head Screw	Schraube mit Innensechskant	2
58	99706-58	4BA x 1/8 inch Socket Set Screw	Gewindestift	3
*59	99706-59	4BA x 1/2 inch Socket Cap Screw (used in yokes before units numbered)	Schraube (für Gabelgelenke)	-
60	99706-60	2BA x 3/16 inch Socket Set Screw	Gewindestift	16
61	99706-61	2BA x 1/4 inch Socket Set Screw	Gewindestift	1
62	99706-62	---	---	-
63	99706-63	1/4 inch Whitworth x 1/4 inch Socket Set Screw	Gewindestift	3
64	99706-64	5/16 inch BSF x 3/4 inch Socket Cap Head Screw	Schraube	2
65	99706-65	M6x6 mm Socket Set Screw	Gewindestift M6x6	2
66	99706-66	1/4 inch BSF Nylock Nut	Mutter	1
67	99706-67	1/4 inch BSF Half Nut	Mutterersatz	4
68	99706-68	1/4 inch BSF Wing Nut	Flügelmutter	1
69	99706-69	1/4 inch Washer	Scheibe	5
**70	99706-70	6BA x 5/16 inch Instrum. Head Screw	Schraube	3
71	99706-71	5/16 inch Washer	Scheibe	2
72	99706-72	M3x3 mm Socket Set Screw	Gewindestift M3x3	1
73	99706-73	M5x5 mm Socket Set Screw	Gewindestift M5x5	6
74	99706-74	M6x8 mm Socket Set Screw	Gewindestift M6x8	3
75	99706-75	M6 x20 mm S. Cap Head Screw	Schraube M6x20	5
76	99706-76	M5x30 mm S. Cap Head Screw	Schraube M5x30	2
77	99706-77	M3x8 mm Pan Head Screw	Schraube M3x8	9
78	99706-78	M3x16 mm Countersink Head Screw	Schraube M3x16	4
79	99706-79	M3.5x5 mm Pan Head Screw	Schraube M3.5x5	1
80	99706-80	M5X16 mm Countersink Head Screw	Schraube M5x16	6
81	99706-81	M5X16 mm Pan Head Screw	Schraube M5x16	2
82	99706-82	M4 x15 mm Socket Cap Head Screw	Schraube M4x15	3
83	99706-83	1/2 x 5/8 x 5/8 inch Self Lubrication Bronze Bearing	Bronzelager	10
84	99706-84	1/2 x 5/8 x 3/4 inch Self Lubrication Bronze Bearing	Bronzelager	5
85	99706-85	3/16 x 5/16 x 1/4 inch Self Lubrication Bronze Bearing	Bronzelager	2
86	99706-86	3/8 x 1/2 x 1/2 inch Self Lubrication Bronze Bearing	Bronzelager	2
87	99706-87	1/2 inch Collar	Stelling	3
88	99706-88	3.5 mm Shakeproof Washer	Scheibe	1
89	99706-89	5 mm Washer	Scheibe	2
90	99706-90	---	---	-
91	99706-91	Knurled Steel Roller	Rolle, gerändelt	-
92	99706-92	Polypropylene Roller	Rolle, Kunststoff	-
93	99706-93	---	---	-
94	99706-94	Brass Pad	Messingunterlage	3

* Not shown

* Nicht abgebildet

** Pos. 46, 49, 50 and 70 are Part
of Pos. No. 48

** Pos. 46, 49, 50 und 70 sind
Teile der Pos. Nr. 48

NUMMERICAL INDEX OF PARTS
TEILE INDEX

<u>Part No.</u> <u>Teil Nr.</u>	<u>Page</u> <u>Seite</u>	<u>Part No.</u> <u>Teil Nr.</u>	<u>Page</u> <u>Seite</u>	<u>Part No.</u> <u>Teil Nr.</u>	<u>Page</u> <u>Seite</u>
107 ... 5		81524B ... 9		99706-41 ... 20	
108 ... 5		81524L ... 9		99706-42 ... 20	
110-2 ... 5		81524LA ... 9		99706-43 ... 20	
12934A ... 9		81566 ... 7		99706-44 ... 20	
12964C ... 5		81567A ... 7		99706-45 ... 20	
21111 ... 5		81567B ... 7		99706-46 ... 20	
22514 ... 9		88 ... 5		99706-47 ... 20	
22560 ... 5		89 ... 9		99706-48 ... 20	
22560A ... 9		92132 ... 5		99706-49 ... 20	
22560B ... 5		94 ... 9		99706-5 ... 20	
22562A ... 20		99623A ... 5		99706-50 ... 20	
22686C ... 9		99683M ... 20		99706-51 ... 21	
22743 ... 5		99706 ... 20		99706-52 ... 21	
22836 ... 7		99706-10 ... 20		99706-53 ... 21	
22874 ... 20		99706-11A ... 20		99706-54 ... 21	
22894AD ... 5, 9		99706-11B ... 20		99706-55 ... 21	
22894AY ... 5		99706-11C ... 20		99706-56 ... 21	
22894W ... 5		99706-12A ... 20		99706-57 ... 21	
258 ... 7		99706-12B ... 20		99706-58 ... 21	
35780B ... 7		99706-12C ... 20		99706-59 ... 21	
51487 ... 9		99706-13 ... 20		99706-6 ... 20	
69H ... 9		99706-14 ... 20		99706-60 ... 21	
78057 ... 9		99706-15 ... 20		99706-61 ... 21	
80655D ... 5		99706-16 ... 20		99706-62 ... 21	
80661B ... 7		99706-17B ... 20		99706-63 ... 21	
80665D ... 5		99706-17C ... 20		99706-64 ... 21	
80667 ... 5		99706-18 ... 20		99706-65 ... 21	
80668 ... 5		99706-19 ... 20		99706-66 ... 21	
80669A ... 5		99706-2 ... 20		99706-67 ... 21	
80669B ... 5		99706-20 ... 20		99706-68 ... 21	
80676 ... 5		99706-21 ... 20		99706-69 ... 21	
80676A ... 5		99706-22 ... 20		99706-7 ... 20	
80696A ... 5		99706-23 ... 20		99706-70 ... 21	
80759 ... 5		99706-24 ... 20		99706-71 ... 21	
80760A ... 7		99706-25 ... 20		99706-72 ... 21	
80858AX ... 5		99706-26A ... 20		99706-73 ... 21	
81086C ... 5		99706-26B ... 20		99706-74 ... 21	
81086G ... 5		99706-27 ... 20		99706-75 ... 21	
81246 ... 5		99706-28 ... 20		99706-76 ... 21	
81254A ... 5		99706-29 ... 20		99706-77 ... 21	
81256A ... 5		99706-30 ... 20		99706-78 ... 21	
81287A ... 5		99706-31 ... 20		99706-79 ... 21	
81293 ... 5		99706-32 ... 20		99706-7B ... 20	
81294 ... 5		99706-33 ... 20		99706-8 ... 20	
81303FL ... 9		99706-34 ... 20		99706-80 ... 21	
81303FLA ... 9		99706-35 ... 20		99706-81 ... 21	
81350D ... 5		99706-36 ... 20		99706-82 ... 21	
81501LP ... 9		99706-37 ... 20		99706-83 ... 21	
81503M ... 9		99706-38 ... 20		99706-84 ... 21	
81503MA ... 9		99706-39 ... 20		99706-85 ... 21	
81503N ... 9		99706-3B ... 20		99706-86 ... 21	
81505L ... 9		99706-4 ... 20		99706-87 ... 21	
81520LA ... 9		99706-40 ... 20		99706-88 ... 21	

NUMMERICAL INDEX OF PARTS
TEILE INDEX

<u>Part No.</u> <u>Teil Nr.</u>	<u>Page</u> <u>Seite</u>	<u>Part No.</u> <u>Teil Nr.</u>	<u>Page</u> <u>Seite</u>	<u>Part No.</u> <u>Teil Nr.</u>	<u>Page</u> <u>Seite</u>
99706-89 ...	21				
99706-9 ...	20				
99706-90 ...	21				
99706-91 ...	21				
99706-92 ...	21				
99706-93 ...	21				
99706-94 ...	21				
99706A ...	20				
999-126 ...	20				
999-127 ...	20				
999-234B ...	20				
B					
BP108 ...	5				
C					
CO67D ...	7				
G					
G29912 ...	20				
H					
HA1286B ...	5				
HA1349 ...	5				
HA58C ...	5				
HA58D ...	5				
HA58F ...	5				
HS106 ...	5				
HS110A ...	5				
HS24C ...	9				
HS52B ...	5				
HS53B ...	5				

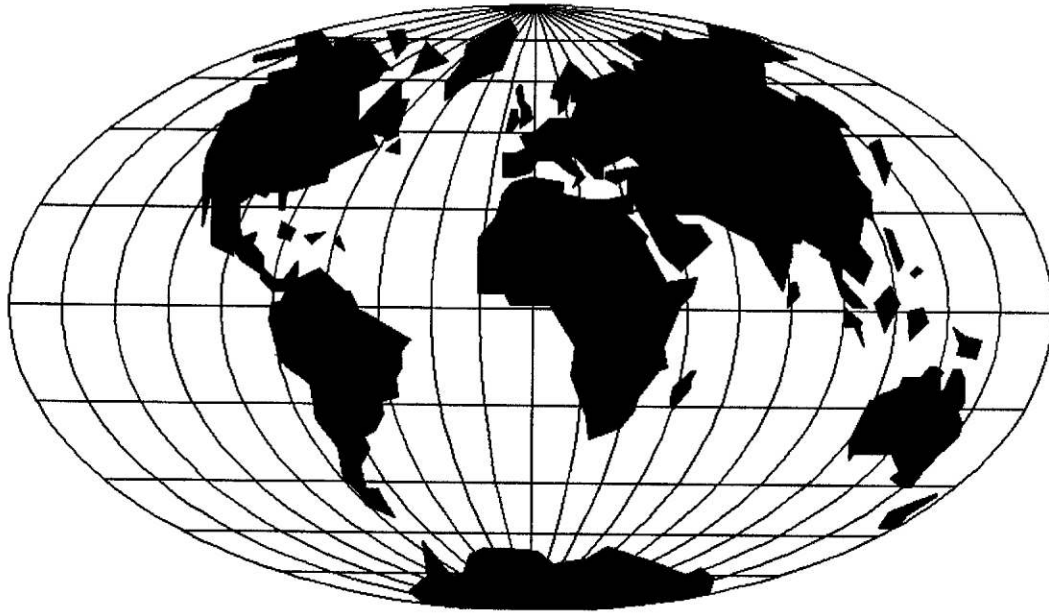

WORLDWIDE SALES AND SERVICE
WELTWEITER VERKAUF UND KUNDENDIENST

Union Special maintains sales and service facilities throughout the world. These offices will aid you in the selection of the right sewing equipment for your particular operation. Union Special representatives and service technicians are factory trained and are able to serve your needs promptly and efficiently. Where ever your location, there is a qualified representative to serve you.

Union Special unterhält Verkaufs- und Kundendienst-Niederlassungen in der ganzen Welt. Diese helfen Ihnen in der Auswahl der richtigen Maschine für Ihren speziellen Bedarf. Union Special Vertreter und Kundendiensttechniker sind in unseren Werken ausgebildet worden, um Sie schnell und fachmännisch zu bedienen.

 **Union Special**[®]
Finest Quality