



JUKI[®]
TOKYO JUKI INDUSTRIAL CO., LTD.



東京重機工業株式会社

営業本部・東京都港区赤坂舞臺町23 TEL.(203)8241(大代)
本社工場・東京都調布市国領町8-2 TEL.(480)1111(大代)

HOW TO MAKE USE OF THIS PARTS BOOK

1. This parts book is divided, as a basic principle, into various sections according to the functions of respective parts.
2. The figures on the illustrations indicate the corresponding numbers (Ref. No.) shown by the Index.
3. Explanation of codes
 - 1) The parts with * mark in the "Note" column means these parts are changed, added, obsoleted or revised this time compared to the preceding parts list.
 - 2 For the parts with the codes * and #, in "Note" column, please refer to explanation under separate sheet or under the sketch.
- 2) The codes in the "E.C." (Engineering Change) column indicate following changes:
 - 1 A.1/75 Added in January, 1975
 - 2 D.1/75 Obsoleted from January, 1975
(In this case, only when substitute part can be used intact, this part number will be shown in the "品名" column of Japanese "Description").
 - 3 M.1/75 The amount required (Amt. Req.) is changed from January, 1975
(In this case, the figure in the "Amt. Req." column shows the changed amount figure.)
 - 4 C.1/75 Error in the part number was found in January, 1975, so revised to correct part number.
(In this case, correct part number is written in the "Part No." column and the wrong part number is written down in the "品名" column.

(Example)

Ref. No.	Note	Part No.	Description	E.C.	品名	Amt. Req.
	注記	品番		変更年月	品名	数量
1	*	B1234-123-000	Needle bar	C.3/75	B1234-723-000	1
		↑			↑	
		Correct No.			Wrong No.	

Note: Consequently, in case C code is entered in the "E.C." column, the part number in the "品名" column is wrong, so please do not place your order with this wrong part number

- 3) The codes on the "Amt. Req." column indicate the following:
 - 1 2 means required amount, namely 2 ea.
 - 2 2.0 means required length, namely 2 meter (in this case the unit is meter).
 - 3 --- Part which was obsoleted from this parts list.
 - 4 1 This is assembly part and is written down in English as "asm." and as "(組)", "(組み)" in Japanese.
 - (1)
 - (2)
 - (3)
 means parts which construct assembly unit and the part just above this is shown the assembly of these parts.

(Example)

Ref. No.	Note	Part No.	Description	E.C.	品名	Amt. Req.
	注記	品番		変更年月	品名	数量
10		B1234-012-0A0	Frame asm.		フレーム(組)	1
11		B1123-012-000	Frame		フレーム	(1)
12		SS-7111510-SP	Screw		止ネジ	(2)

4 Examples of interchangeability parts

1) In case of changing interchangeable parts

Ref. No.	Note	Part No.	Description	E.C.	品名	Amt. Req.
	注記	品番		変更年月	品名	数量
1	*	B1301-400-000	Needle bar	D.12/74	Needle bar	-
1-1	*	B1301-400-000A	Needle bar	A.12/74	Needle bar	1

2) In case of changing no-interchangeable parts

Ref. No.	Note	Part No.	Description	E.C.	品名	Amt. Req.
	注記	品番		変更年月	品名	数量
1	*	B1234-200-000	Frame cover	D.12/74	B1234-300-000	
1-1	*	B1234-300-000	Frame cover	A.12/74	フレームカバー	1

(In this case, order by the new part number)

There are following listed parts list which are associated with the parts list of these models.

上の機種に関連するパーツリストとして下記の内容のパーツリストがあります。

- 1.
- 2.
- 3.

パーツリストの見方

1. このパーツリストは、原則として、機構別に分類された各項目からなりたっております。
2. 図に示された部品の品番は、図にふられてあるNo(Ref.No)に対応するIndexによって、その品番がわかります。
3. 記号の説明

- 1) ① "注記"欄に☆印がついた部品は、前回のパーツリストと比較して今回、変更、追加、削除又は訂正された部品を意味します。
 - ② "注記"欄に◇印がついた部品は、"注記"の説明を参照して下さい。
 - 2) "変更年月"欄の記号は、それぞれ次の様な内容を意味しております。
 - ① A. 10/74.....1974年10月より追加された。
 - ② D. 1/75.....1975年1月より削除された。
 この場合、代替部品がそのまま使用できる場合に限る、その品番を和文品名欄に表示します。
 - ③ M. 2/75.....1975年2月より数量が変更になった。
 - ④ C. 3/75.....1975年3月に品番のミスが判明したため、正しい品番に訂正された。
- この場合は品番欄には正しい品番が記入され、間違いの品番は和文品名欄に記入されます。

(例)

Ref. No.	Note 注記	Part No. 品番	Description	E.C. 変更年月	品名	Amt. Req. 数量
1		B1234-123-000	Needle bar	C. 3/75	B1234-723-000	1

(正しい品番) (間違っていた品番)

- ⑤ 従って図案欄に○記号の入っている場合は、和文品名欄の品番は間違っている品番を意味しておりますので、この品番で部品を注文しないで下さい。
- 3) 数量欄の記号は、それぞれ次の様な内容を意味しております。

- 数量
- ① 2必要な数量、即ち2個を意味します。
 - ② 2 0必要な長さ、即ち2メートルを意味します(この場合単位はメートルです)
 - ③このパーツリストから削除された部品です。
 - ④ 1組部品で品名欄に英文で"asm"、和文で"クミ"又は(組)と表示してあります。
 - (1)組部品を構成している子部品を意味し、そのすぐ上にある部品が組部品です。
 - (2)組部品を構成している子部品を意味し、そのすぐ上にある部品が組部品です。

(例)

Ref. No.	Note 注記	Part No. 品番	Description	E.C. 変更年月	品名	Amt. Req. 数量
10		B1234-012-0A0	Frame asm.		フレーム クミ	1
11		B1234-012-000	Frame		フレーム	(1)
12		SS-7111510-SP	Screw		トメネジ	(2)

4. 表示例

- 1) 互換性がない部品の変更の場合

Ref. No.	Note 注記	Part No. 品番	Description	E.C. 変更年月	品名	Amt. Req. 数量
1	☆	B1301-400-000	Needle bar	D. 12/74	ハリホウ	-
1-1	☆	B1301-400-000-A	Needle bar	A. 12/74	ハリホウ	1
- 2) 互換性がある部品の変更の場合

Ref. No.	Note 注記	Part No. 品番	Description	E.C. 変更年月	品名	Amt. Req. 数量
1	☆	B1234-200-000	Frame cover	D. 12/74	B1234-300-000	-
1-1	☆	B1234-300-000	Frame cover	A. 12/74	フレームカバー	1

この場合は新しい品番でご注文下さい。

CONTENTS

目次

1. MACHINE HEAD & MISCELLANEOUS COVER COMPONENTS
頭部外装関係..... 1
2. MAIN SHAFT & SAFETY CLUTCH COMPONENTS
天秤, 上軸, 安全装置関係..... 3
3. NEEDLE BAR FRAME & PRESSER FOOT COMPONENTS
針棒, 針棒揺動, 押工棒関係..... 5
4. FEED POCK SHAFT COMPONENTS
送り, 送り調節関係..... 7
5. SEWING HOOK DRIVING SHAFT COMPONENTS
下軸, 水平釜関係..... 9
6. THREAD TENSION & THREAD WINDER COMPONENTS
水平軸, 糸調子, 糸巻車関係..... 11
7. EXCLUSIVE PARTS FOR LG-158-1
LG-158-1 専用部品..... 13

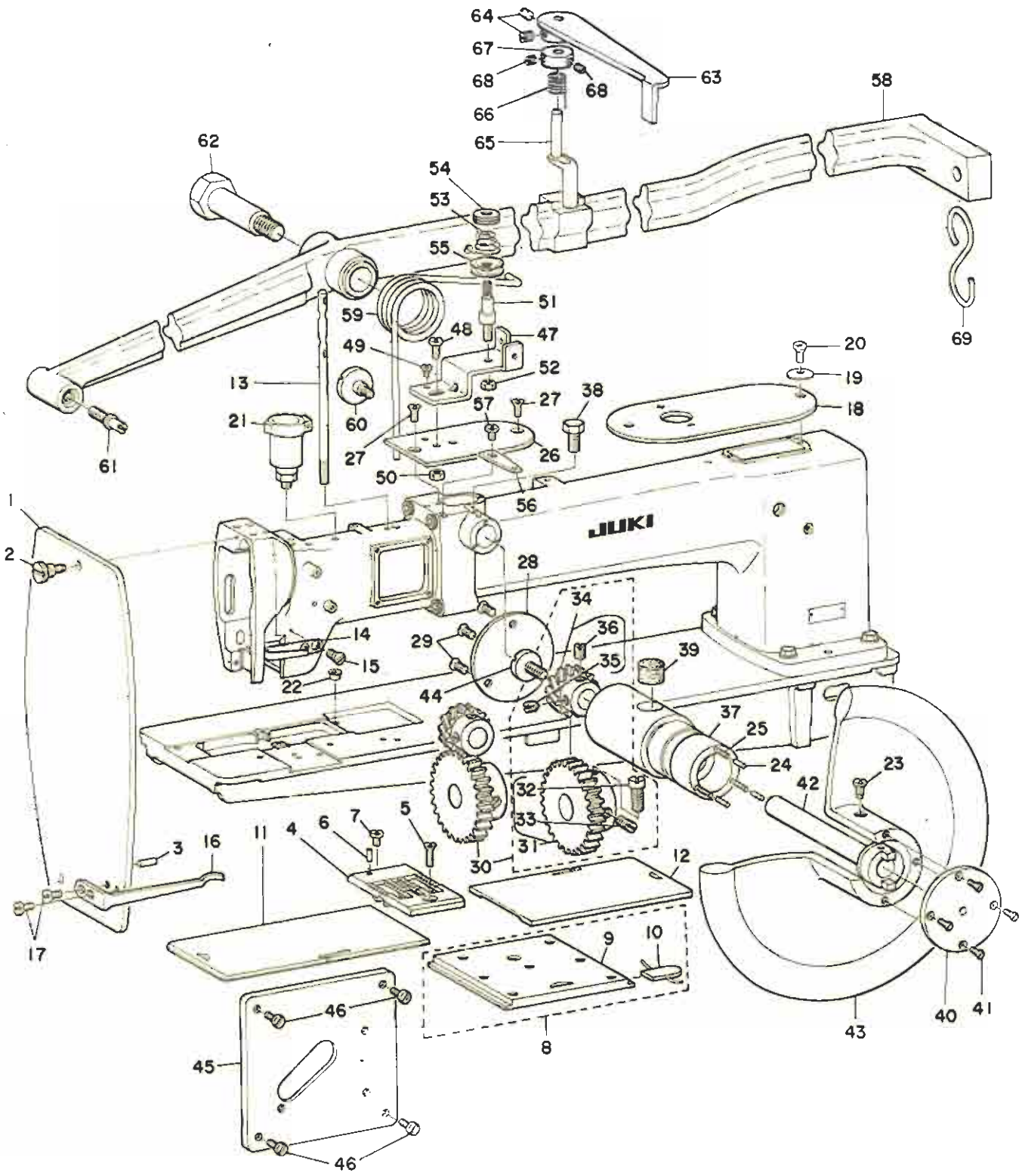

1. MACHINE HEAD & MISCELLANEOUS COVER COMPONENTS

頭部外装関係

Ref.No.	Note 注記	Part No. 品番	Description	E. C. 変更年月	品名	Amt. Req. 個数
1		B3101158000	Face plate		面板	1
2		A1132025000	... Screw		〃 〃 止ネジ	1
3		B1130051000	... Pin		〃 〃 止ピン	1
4		B1109057N00	Throat plate 3/4"		針板 3/4"	1
5		B1114057000	... Screw		〃 〃 止ネジ	1
6		B1104051000	... Pin		〃 〃 止ピン	1
7		SS6090630SP	... Screw		〃 〃 案内ネジ	1
8		B1110057080	Bed slide asm., front		滑り板 (前)	1
9		B1110057000	Bed slide		〃 〃	(1)
10		B11110510A0	Bed slide stopper asm.		〃 〃 止メ (前)	(1)
11		B1112057N00	Bed slide, left 3/4"		〃 〃 (左) 3/4"	1
12		B1113057N00	Bed slide, right 3/4"		〃 〃 (右) 3/4"	1
13		B1114157000	Needle thread guide pin		糸案内棒	1
14		B1131057000	Needle thread guide		糸案内 (中)	1
15		SS2090710SP	... Screw		〃 〃 止ネジ	1
16		B1131158000	Needle thread guide, lower		〃 〃 (下)	1
17		SS7090610SP	... Screw		〃 〃 止ネジ	2
18		B1150158000	Top cover		天板	1
19		B1152051000	... Washer		〃 〃 止ネジ座金	1
20		SD0630241-SD	... Screw		〃 〃 止ネジ	1
21		B1155053000	Oil cup		上メッロットオイルカップ	1
22		B11570090A0	Red oil cup		オイルカップ	1
23		B1288057000	Screw		補助ハズミ車止ネジ	1
24		B1290057A00	Pin		〃 〃 ピン	3
25		B1290057B00	Spring		〃 〃 バネ	3
26		B1291158000	Top cover, intermediate		〃 〃 軸天板	1
27		SS2110920SP	... Screw		〃 〃 止ネジ	2
28		B1292057000	Side plate		〃 〃 窓板	1
29		SS2110920SP	... Screw		〃 〃 止ネジ	3
30		B1293057080	Auxiliary hand wheel driving gear asm.		補助ハズミ車歯車 (組)	1
31		B1293057A00	Gear asm., large		〃 〃 大歯車 (組)	(1)
32		B1293057B00	... Screw		〃 〃 止ネジ	(1)
33		SS6661110SP	... Screw		〃 〃	(1)
34		B12940570A0	Gear asm., small		〃 〃 小歯車 (組)	(1)
35		SS8660670SP	... Screw		〃 〃 止ネジ A	(1)
36		SS8660610TP	... Screw		〃 〃 止ネジ B	(1)
37		B1295057000	Bushing		〃 〃 軸メタル	1
38		B1906057000	... Screw		〃 〃 止ネジ	1
39		B1203051000	... Oil felt		〃 〃 フェルト	1
40		B1296057000	Thrust plate		〃 〃 スラスト	1
41		SS2090710SP	... Screw		〃 〃 止ネジ	4
42		B12970570A0	Auxiliary hand wheel driving shaft asm.		〃 〃 軸スラスト受 (組)	1
43		B1299057000	Auxiliary hand wheel		補助ハズミ車	1
44		SS7161040SP	... Screw		〃 〃 小歯車押上げネジ	1
45		B1434158000	Side plate		窓板	1
46		SS7111120SP	... Screw		〃 〃 止ネジ	4
47		B3208158000	Thread winder tension bracket		下糸案内台	1
48		SS7110910SP	... Screw		糸案内台止ネジ A	1
49		SS6080710SP	... Screw		〃 〃 B	1
50		NS6110310SP	... Nut		〃 〃 ナット	1
51		B3219232000	Thread winder tension post		糸案内台支柱	1
52		NS6110310SP	Nut		〃 〃 ナット	1
53		B3218232000	Tension spring		〃 〃 バネ	1
54		B3216047000	Tension nut		〃 〃 ナット	1
55		B3214047000	Tension disc		〃 〃 III	2
56		B2510158000	Thread winder thread guide		糸案内案内	1
57		SS7090710SP	... Screw		〃 〃 止ネジ	1
58		B3401057000	Presser bar lifting lever		膝上げテコ	1
59		B3403057000	Spring		〃 〃 バネ	1
60		SD0800431-SP	Hinge screw		〃 〃 段ネジ	1
61		B3404057000	Screw stud		〃 〃 ピン	1
62		B3402057000	Hinge screw		膝上げ支持段ネジ	1
63		B3405057000	Lifting lever stopper		前テコ支えレバー	1
64		SS8110750SP	... Screw		〃 〃 止ネジ	2
65		B3406057000	Lifting lever stopper stud		前テコ支え軸	1
66		B3408057000	... Spring		〃 〃 バネ	1
67		CS0640866SB	... Thrust collar		〃 〃 スラスト	1
68		SS8110320SP	... Screw		〃 〃 止ネジ	2
69		B3409057000	S shaped hook		S型金具 (A)	1

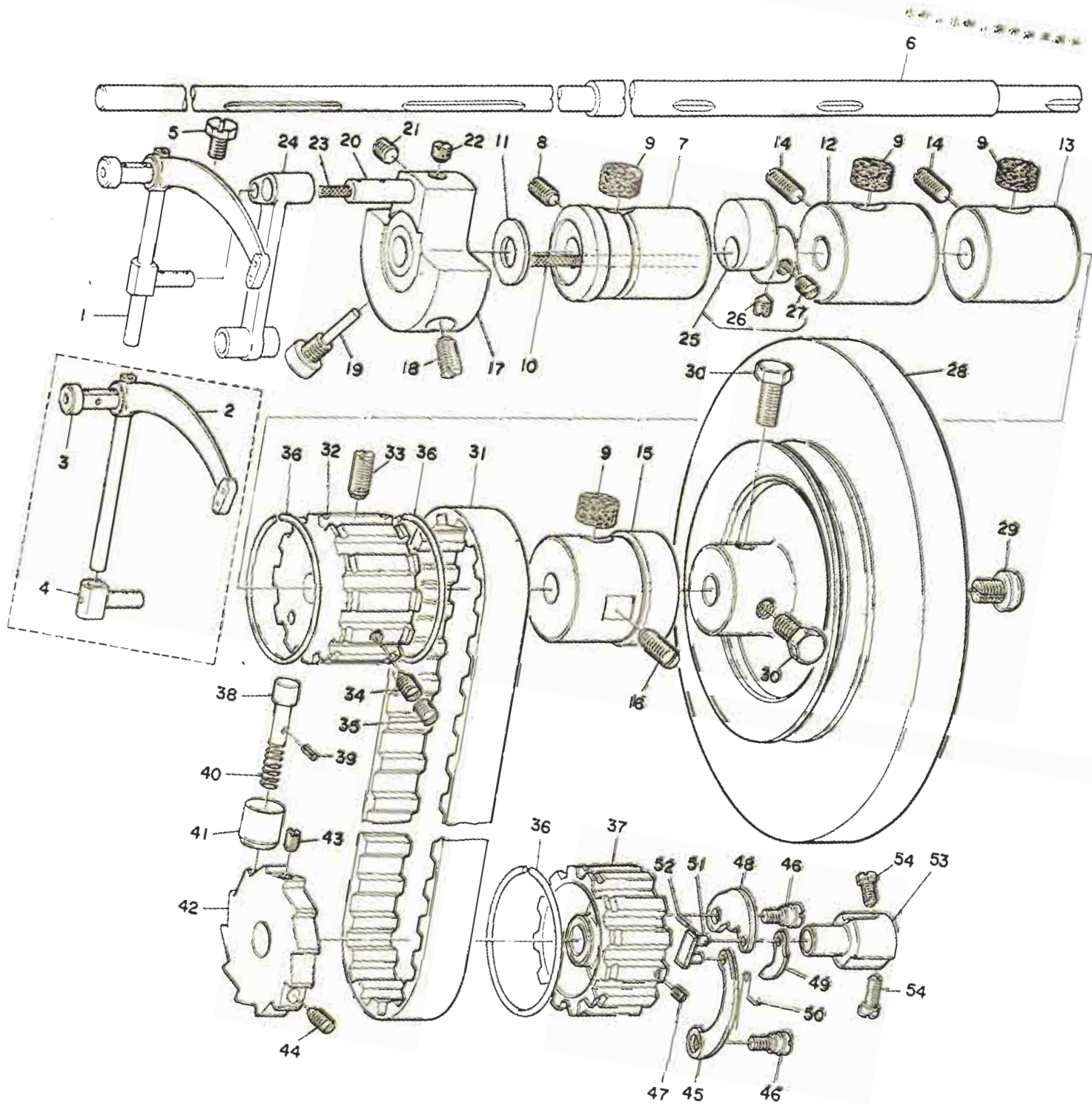

2. MAIN SHAFT & SAFETY CLUTCH COMPONENTS

天秤, 上軸, 安全装置関係

Ref.No.	Note 注記	Part No. 品番	Description	E. C. 変更年月	品名	Amt. Req. 個数
1		B19050570A0	Thread take-up lever asm.		天秤 (組)	1
2		B1905057000	Thread take-up lever		天秤	(1)
3		B1906051000	Shaft		" 交工軸	(1)
4		B1907057000	Thread take-up lever connection		" スライド軸	(1)
5		B1906057000	. . . Screw		" 交工軸止ネジ	1
6		B1201158000	Main shaft		上軸	1
7		B1202051000	Main shaft bushing, front		" 前メタル	1
8		SS8151550SP	. . . Screw		" " 止ネジ	1
9		B1203051000	. . . Oil felt		" " フェルト	4
10		B1204051000	. . . Oil wick		" " 油心	1
11		B1205051000	. . . Washer		" " 垫金	1
12		B1203158A00	Main shaft bushing, intermediate(1)		" 中メタル (1)	1
13		B1203158B00	Main shaft bushing, intermediate(2)		" " (2)	1
14		SS8152030SP	. . . Screw		" " 止ネジ	2
15		B1216057000	Main shaft bushing, rear		" 後メタル	1
16		SS8152030SP	. . . Screw		" " 止ネジ	1
17		B1206057000A	Counterweight		釣合錠	1
18		SS8681650TP	. . . Screw		" 止ネジ	1
19		B1207057000	. . . Screw stud		" ボン	1
20		B1210051000	Needle bar crank pin		針棒クランクピン	1
21		SS8660530TP	. . . Screw		" " 止ネジ(A)	1
22		SS8660810TP	. . . Screw		" " (B)	1
23		B1204051000	. . . Oil wick		" " 油心	1
24		B1408057000	Needle bar crank rod		針棒クランクロッド	1
25		B14500570A0	Upper feed eccentric asm.		上送りカム (組)	1
26		SS8660670SP	. . . Screw		" " 止ネジ(A)	(1)
27		SS8660610TP	. . . Screw		" " (B)	(1)
28		B1227158000	Hand wheel		ハズミ車	1
29		B1233012000	. . . End screw		" " 押上ネジ	1
30		SS9201813CP	. . . Screw		" " 止ネジ	2
31		B1301158000	Timing belt		タイミングベルト	1
32		B1302051000	Sprocket wheel, upper		上スプロケット	1
33		SS8681650TP	. . . Screw		" " 止ネジ(A)	1
34		B1302057B00	. . . Taper screw		" " "	1
35		SS8680810TP	. . . Screw		" " 止ネジ	1
36		B1214019000	Sprocket wheel ring		スプロケットリング	3
37		B1303055A00	Sprocket wheel, lower		下スプロケット	1
38		B1306158000	Safety clutch push button		安全装置押シボタン	1
39		B1309057000	. . . Cotter pin		" " ボン	1
40		B1307057000	. . . Spring		押シボタンバネ	1
41		B1308057000	. . . Sleeve		安全装置押シボタンブッシュ	1
42		B1314158000	Safety clutch ratchet gear		" " ラatchetギヤ	1
43		SS8681650TP	. . . Screw		" " 止ネジ(A)	1
44		SS8151550SP	. . . Screw		" " 止ネジ(B)	1
45		B1305055000	Safety clutch spring		安全装置バネ	1
46		SD0640322TP	. . . Ring screw		" " 爪ねじ	2
47		SS8090410SP	. . . Screw		" " バネ押ネジ	1
48		B1307055000	Safety clutch hook		" " 爪	1
49		B1308055000	Safety clutch counter-hook		" " 逆爪	1
50		B1309055000	. . . Spring		" " バネ	1
51		B1310055000	Safety clutch small link		" " 小リンク	1
52		B1314055000	. . . Pin		" " ボン	1
53		B1311055000	Safety clutch body		" " 受ケ	1
54		B1316055000	. . . Screw		" " 止ネジ	2

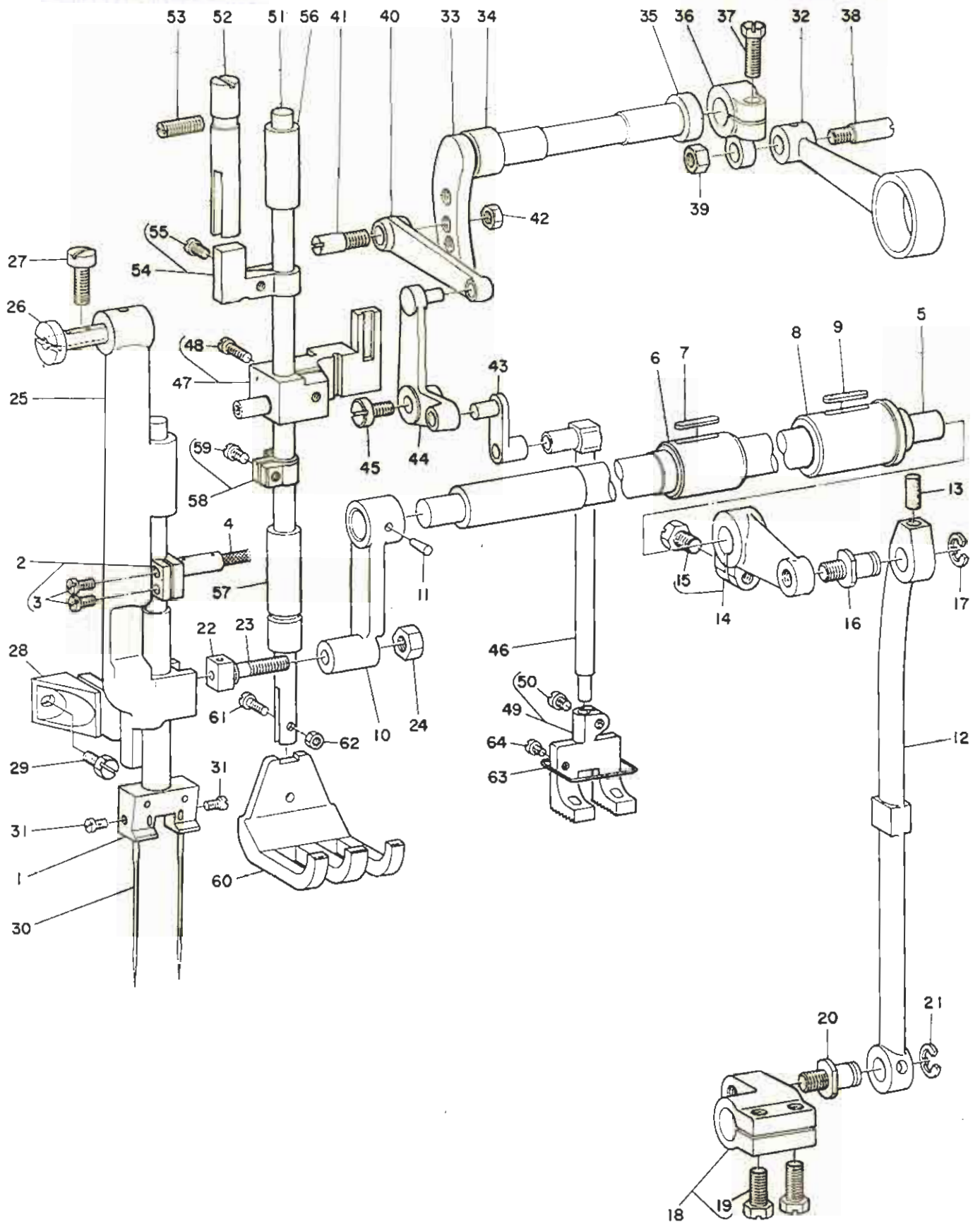

3. NEEDLE BAR FRAME & PRESSER FOOT COMPONENTS

針棒, 針棒揺動, 押エ棒関係

Ref.No.	Note 注記	Part No. 品番	Description	E. C. 変更年月	品名	Amt. Req. 個数
1		B1401057N00A	Needle bar 3/4"		針棒 3/4"	1
2		B14110570A0	Needle bar connection asm.		" 括キ (組)	1
3		SS7110720-SP	. . . Screw		" " 締ネジ	(2)
4		B1204051000	. . . Oil wick		" " 油心	1
5		B1420158000	Needle bar frame rock shaft		" 揺動軸	5
6		B1429158000	. . . Bushing, intermediate		" " 中メタル	1
7		B1304012A00	. . . Oil felt		" " "フェルト	1
8		B1430158000	. . . Bushing, rear		" " 後メタル	1
9		B1304012A00	. . . Oil felt		" " "フェルト	1
10		B1421057000	Rock shaft front crank		" 揺動前部腕	10
11		PT0402200-00	. . . Pin		" " ノックピン	1
12		B1422158000	Needle bar frame driving rod		" 揺動ロッド	1
13		B1412051000	. . . Oil felt		" " フェルト	1
14		B14311580A0	Rock shaft rear crank asm.		" 揺動後部腕 (組)	1
15		SS9151540-SR	. . . Screw		" " 締ネジ	(1)
16		B1424158000	. . . Hinge screw		" " 絞ネジ	1
17		RF0700000-K0	. . . Snap ring		" " "Eリング	1
18		B14231580A0	Driving rod crank asm.		" 揺動送り腕 (組)	1
19		SS9151540-SR	. . . Screw		" " 締ネジ	(2)
20		B1424158000	. . . Hinge screw		" " 絞ネジ	20
21		RF0700000-K0	. . . Snap ring		" " "Eリング	1
22		B1425051000	Slide block		" 揺動角駒	1
23		B1426051000	Screw stud		" " 軸	1
24		NS6620310-SN	Nut		" " ナット	1
25		B1426057000	Needle bar frame		" 揺動台	25
26		B1427057000	Shaft		" " 軸	1
27		B1427057B00	. . . Screw		" " 止ネジ	1
28		B1428057000	Needle bar frame guide		揺動台案内	1
29		SS9111010-SP	. . . Screw		" " 止ネジ	1
30		MDD100B2500	Needle DD x 1 #25		針 DDx1 #25	2
31		SS7620610-SP	. . . Screw		針止ネジ	2
32		B1451057000	Upper feed rod		上送りロッド	1
33		B1452057000	Walking bar rock shaft		上送り軸	1
34		B1453057000	Bushing, front		" " 前メタル	1
35		B1457057000	Bushing, rear		" " 後メタル	1
36		B14540570A0	Walking bar rock shaft crank		上送り腕 (組)	35
37		B1468057000	. . . Clamp screw		" " 締ネジ	(1)
38		B145405300B	. . . Screw stud		" " 軸	1
39		NS6660430-SP	. . . Nut		" " 固定ナット	1
40		B1458057000	Walking bar rock shaft connecting link		上送り連結リンク	40
41		B1456057000	Feed adjusting screw		送り調節絞ネジ	1
42		NS6150430-SP	. . . Nut		" " ナット	1
43		B1455057000	Walking bar driving link		送り揺動リンク	1
44		B1459057000	L shaped link		L型リンク	1
45		SS6111140-SP	. . . Screw		" " 止ネジ	45
46		B1466057000	Walking bar		上送り棒	1
47		B14600570A0	Presser bar lifting bracket asm.		押エ上ゲテコ台 (組)	1
48		B1467057000	. . . Clamp screw		" " 締ネジ	(1)
49		B1470158NA0	Walking foot asm. 3/4"		押エ中足 3/4" (組)	1
50		SS7090910-TP	. . . Screw		" " 締ネジ	(1)
51		B1501057000	Presser bar		押エ棒	50
52		B1502051000	Presser bar guide sleeve		" " 括キ案内筒	1
53		SS8152030-SP	. . . Screw		" " 止ネジ	1
54		B15040570A0	Presser bar connection guide asm.		" " 括キ案内 (組)	1
55		SS7090910-SP	. . . Screw		" " 止ネジ	(1)
56		B1503051A00	Presser bar bushing, upper		" " 上メタル	55
57		B1503057000	Presser bar bushing, lower		" " 下メタル	1
58		B15070510A0	Presser bar connection asm.		" " 括キ (組)	1
59		SS7090910-SP	. . . Screw		" " 止ネジ	(1)
60		B1525057N00	Presser foot asm. 3/4"		押エ足 3/4"	60
61		SS6091210-TP	. . . Screw		" " 止ネジ	1
62		NS6090310-SP	. . . Nut		" " ナット	1
63		B1419158N00	Needle guard 3/4"		針安全カバー 3/4"	1
64		SS7080520-SP	. . . Screw		" " 止ネジ	1

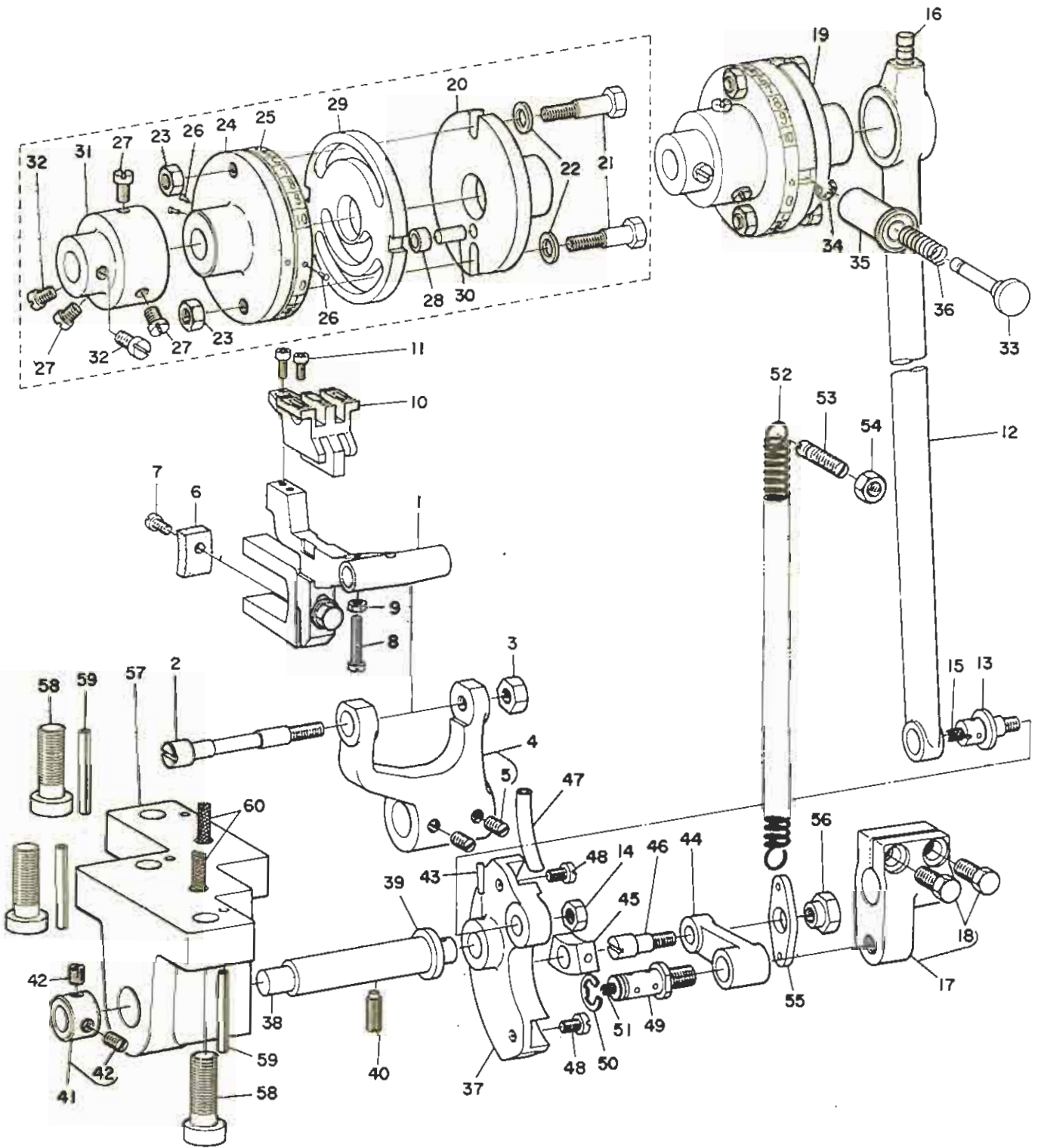

4 FEED ROCK SHAFT COMPONENTS

送り、送り調節関係

Ref.No.	Note 注記	Part No. 品番	Description	E. C. 変更年月	品名	Amt. Req. 個数
1		B16020570A0	Feed bar asm.		送り台(組)	1
2		B1603057000	Feed bar shaft		送り台軸	1
3		NS6160520SP	Nut		" " ナット	1
4		B16160570A0	Feed rocker asm.		送り台腕(組)	1
5		SS8660970TP	... Screw		" " 止ネジ	(2)
6		B1605051000	Oil felt		送り台ニ又油溜フェルト	1
7		SS5080710SP	... Screw		" " 止ネジ	1
8		SS6081810SP	Adjusting screw		送り調節ネジ	1
9		NS6080210SP	Nut		" " ナット	1
10		B1613057N00	Feed dog 3/4"		送り犬	1
11		B1643057000	... Screw		送り歯止ネジ	2
12		B1614158000	Crank connecting rod		水平送りロッド	1
13		B1615158000	... Screw stud		" " 軸	1
14		NS6150430SP	... Nut		" " ナット	1
15		CS5050000-00	Oil wick		" " 油心	1
16		B1226552000	Oil felt		" " フェルト	2
17		B16181580A0	Feed rock shaft crank		水平送り腕(組)	1
18		SS9151540SR	... Screw		" " 締ネジ	(2)
19		B16201580A0	Feed eccentric asm.		送り調節(組)	1
20		B1620158000	Feed eccentric		" "	(1)
21		B1628158000	Connecting screw		" " 結合ネジ	(2)
22		B1629158000	... Washer		" " 板金	(2)
23		NS6150430SP	... Nut		" " ナット	(2)
24		B1621158A00	Stitch graduator		" " 目盛板 (A)	(1)
25		B1621158B00	Stitch graduator scale		" " (B)	(1)
26		A116100100B	Rivet		" " 止釘	(3)
27		SS6660710SP	... Screw		" " 止ネジ	(3)
28		B1622158000	Feed eccentric guide roller		" " 案内コロ	(1)
29		B1626158000	Feed eccentric guide		" " 案内カム	(1)
30		B1623158000	... Pin		" " ピン	(1)
31		B1625158000	Feed eccentric retaining collar		送り調節受	1
32		SS6660710TP	... Screw		" " 止ネジ	2
33		B1636158000	Push button		送り調節押しボタン	1
34		RE0400000K0	... Snap ring		押しボタンフリック	1
35		B1637158000	... Bushing		送り調節押しボタンのシ	1
36		B1639158000	... Spring		" " バネ	1
37		B1641158000	Reverse feed link guide		受検リンク案内	1
38		B1642158000	... Shaft		" " 軸	1
39		B1640158000	... Bushing		" " メタル	1
40		SS8151550SP	... Screw		" " 止ネジ	1
41		B1643158000	Thrust collar		案内軸スラスト受	1
42		SS8150510TP	... Screw		" " 止ネジ	2
43		PT0302000S0	Pin		受検リンク案内メタルピン	1
44		B1644158000	Reverse feed link		送り受検リンク	1
45		B1645158000	... Slide block		" " 駒	1
46		B1646158000	... Screw stud		" " 軸	1
47		B1652158000	Oil pipe		" " 給油パイプ	1
48		B1653158000	Stopper screw		" " ストップネジ	2
49		B1649158000	Screw stud		" " 軸	1
50		RE0700000K0	... Snap ring		" " Eリング	1
51		CS5050000-00	... Oil wick		" " 油心	1
52		B1650158000	Spring		受検リンク引張バネ	1
53		B1651158000	... Suspension		引張りバネ掛け	1
54		NS6680410SN	... Nut		" " ナット	1
55		B1647158000	Suspension		受検リンクバネ掛板	1
56		B1648158000	... Nut		バネ掛板止ナット	1
57		B1104158000	Bushing mounting base		下軸後メタル受	1
58		SS9242740CP	... Screw		" " 止ネジ	3
59		PS0400322KP	... Pin		メタル受リンクピン	3
60		CS5050000-00	... Oil wick		下軸後メタル受油心	1

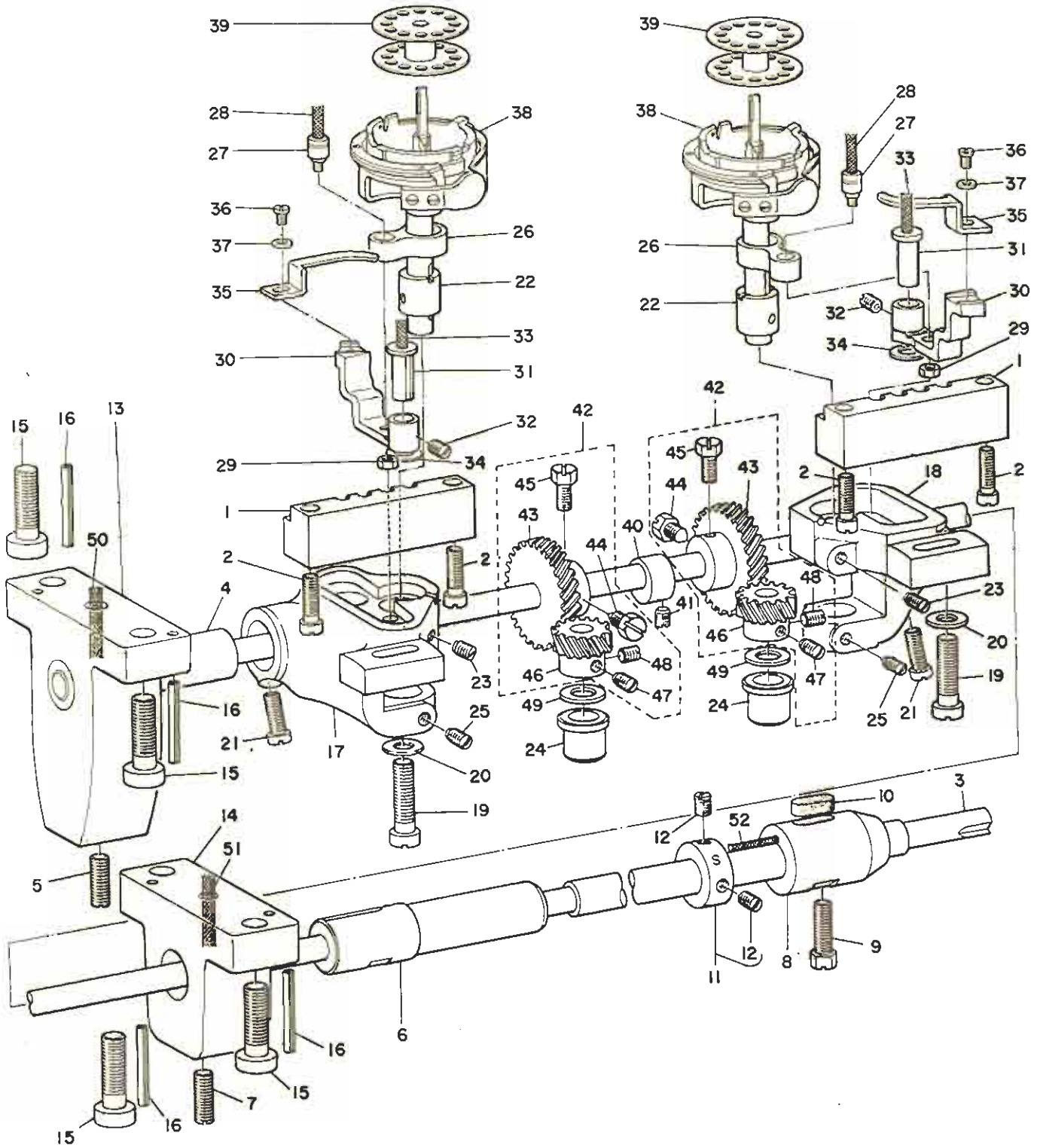

5. SEWING HOOK DRIVING SHAFT COMPONENTS

MDEL LG-158

下軸 水平登回係

Ref.No.	Note 注記	Part No. 品 番	Description	E. C. 変更年月	品 名	Am't. Req. 個数
1		B1800057000	Saddle supporting base		釜軸台受	2
2		SS6151920SP	Screw		止ネジ	4
3		B1801158000	Hook driving shaft		下 軸	1
4		B1802057000	Front bushing		前メタル	1
5		SS8152030SP	Screw		止ネジ	1
6		B1804057B00	Intermediate bushing		中メタル	1
7		SS8152030SP	Screw		止ネジ	1
8		B1808158000	Rear bushing		後メタル	1
9		SS9152130CP	Screw		止ネジ	1
10		B1218012000	Oil felt		フェルト	1
11		B18070570A0	Thrust collar asm.		スラスト受(組)	1
12		SS8150710SP	Screw		スラスト受止ネジ	(2)
13		B1103158000	Front bushing support		前メタル受	1
14		B1104057A00	Intermediate bushing support		中メタル受	1
15		SS9242740CP	Screw		メタル受止ネジ	4
16		PS0400322KP	Pin		メタル受ロックピン	4
17		B1810051000	Hook shaft saddle, left		釜軸台左	1
18		B1811051000	Hook shaft saddle, right		釜軸台右	1
19		SS7762840SP	Screw		止ネジ	2
20		B1812051000	Washer		座金	2
21		SS6153040SP	Clamp screw		締ネジ	2
22		B1814057000	Hook shaft upper bushing		釜軸上メタル	2
23		SS8150710SP	Screw		止ネジ	2
24		B1815051000	Hook shaft lower bushing		下メタル	2
25		SS8150710SP	Screw		止ネジ	2
26		B1820057000	Bobbin case opening lever link		中釜案内リンク	2
27		B1821051000	Crank screw stud		中釜案内フランジピン	2
28		B1204051000	Oil wick		油心	2
29		NS6110420SP	Nut		ナット	2
30		B1822057000	Bobbin case opening lever crank		中釜案内腕	2
31		B1823051000	Pin		軸	2
32		SS8150710SP	Screw		止ネジ	2
33		B1204051000	Oil wick		油心	2
34		B1825158000	Washer		座金	2
35		B1824057000	Bobbin case opening lever		中釜案内	2
36		SS7080510SP	Screw		止ネジ	2
37		WP0371016SD	Washer		座金	2
38		B1830057SA0	Vertical-axis sewing hook asm.		水平座(組)	2
39		B9117057000	Bobbin		本ピン	2
40		B18400510A0	Feed driving eccentric asm.		下送りカム(組)	1
41		SS815058000	Screw		止ネジ	(1)
42		B18160510B0	Hook driving shaft gear asm.		ネジ歯車大(組)	2
43		B18160510A0	Hook driving shaft gear		ネジ歯車大	(2)
44		B1809057A00	Screw (A)		ネジ歯車止ネジ(A)	(2)
45		B1809057B00	Screw (B)		ネジ歯車止ネジ(B)	(2)
46		B18170510A0	Hook shaft gear		ネジ歯車小	(2)
47		SS8660670SP	Screw (A)		止ネジ(A)	(2)
48		SS8660610TP	Screw (B)		止ネジ(B)	(2)
49		B1818051000	Thrust washer		スラスト板	1
50		CA5050000-00	Oil wick		下軸前メタル受油心	1
51		CA5050000-00	Oil wick		中メタル受油心	1
52		CA3030000-00	Oil wick		後メタル油心	1

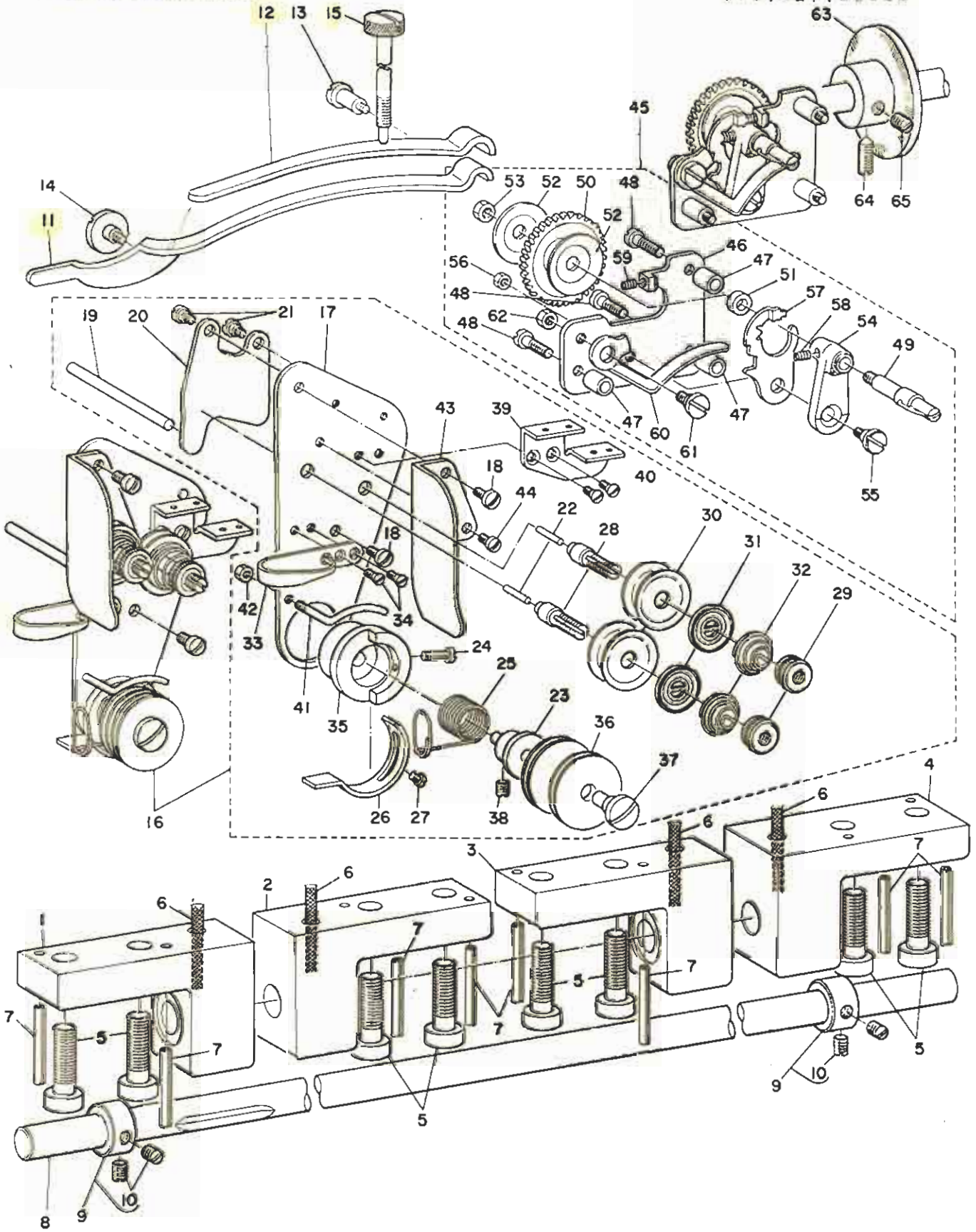

6. THREAD TENSION & THREAD WINDER COMPONENTS

水平軸糸調子糸巻車関係

Ref.No.	Note 注記	Part No. 品番	Description	E. C. 変更年月	品名	Amt. Req. 個数
1		B1105057A00	Feed rock shaft bushing, front		水平送り軸受(前)	1
2		B1105057B00	Feed rock shaft bushing, intermediate		" (中)	1
3		B1105057C00	Feed rock shaft bushing, rear		" (後)	1
4		B1105158000	Feed rock shaft bushing, rear(?)		" (後)2	1
5		S59242740CP	... Screw		" 止ネジ	8
6		C8505000000	... Oil wick		" 油心	4
7		PS0400322KP	Pin		メタル受ノックピン	2
8		B1601158000	Feed rock shaft		水平送り軸	1
9		CS140101A-00	Thrust collar asm.		" "スラスト受け組	2
10		SS8150410-SP	... Screw		" "止ネジ	4
11		B1505053000	Presser bar plate spring		押エ調節板バネ	1
12		B1505057000	Presser bar plate spring(B)		" (B)	1
13		SD0801601-SP	... Hinge screw		押エ板バネ支えネジ	1
14		SD0800481-SP	... Hinge screw		押エ上ゲテコ案内絞ネジ	1
15		B15070570A0	Pressure regulating thumb screw		押エ板バネ調節ネジ(組)	1
16		B31210570A0	Thread tension controller asm.		糸調子台板(組)	1
17		B3121057000	Thread tension controller base		" "	(1)
18		S59110910-SP	... Screw		" "止ネジ	(2)
19		B3122057000	Tension release pin		糸ユルメ押シ棒	(1)
20		B3134057000	Tension release lever		" 受け板	(1)
21		SD0470281-SP	... Screw		" "止ネジ	(2)
22		B3127057000	... Pin		" "ピン	(2)
23		B3123057000	Take-up spring bracket		糸取りバネ軸	(1)
24		S57111110-TP	... Screw		" "止ネジ	(1)
25		B3129057B00	Take-up spring		糸取りバネ	(1)
26		B3143057000	Take-up spring adjusting plate		" 調節板	(1)
27		S57090520-TP	... Screw		" "止ネジ	(1)
28		B3124057000	Tension post		糸調子棒	(2)
29		B3125012000	Thread tension nut		" ナット	(2)
30		B3126012000	Thread tension disc		" 皿	(4)
31		B3132012000	Tension disc presser		" 押エ	(2)
32		B3129053000	Thread tension spring		" バネ	(2)
33		B3140057000	Thread guide		" 糸案内	(1)
34		S52090510-SP	... Screw		" "止ネジ	(2)
35		B3142057000	Take-up spring guide sleeve		" 外筒	(1)
36		B3138057000	Thread guide disc		糸案内口	(1)
37		B3139057000	Thread guide disc stud		" 軸	(1)
38		SS8110520-TP	... Screw		" "止ネジ	(1)
39		B3141057000	Thread guide		糸案内板	(1)
40		S52090510-SP	... Screw		" "止ネジ	(2)
41		B3131057000	Thread guide pin		糸掛け棒	(1)
42		NS6080210-SP	... Nut		" ナット	(1)
43		B3144057000	Thread guard		糸カバー	(1)
44		S57090520-SP	... Screw		" "止ネジ	(1)
45		B32011580B0	Thread winder asm.		糸巻台(組)	1
46		B3201158000	Thread winder base		糸巻台	(1)
47		B3203158000	... Washer		" 取付屋金	(3)
48		S57111810-SP	... Screw		" "止ネジ	(3)
49		B32021580A0	Thread winding shaft asm.		糸巻軸(組)	(1)
50		B3203232000	Thread winder pulley		糸巻車	(1)
51		B3207158000	Collar		" カラー	(1)
52		B3209232000	Washer		" 屋金	(2)
53		NS6120310-SP	Nut		" 止ナット	(1)
54		B3204232000	Thread winder arm		糸巻腕	1
55		B3205232000	... Hinge screw		" 絞ネジ	1
56		NS6110310-SP	... Nut		" ナット	1
57		B3206232000	Thread amount adjusting plate		糸巻軸台調節板	1
58		B3208232000	Spring		" バネ	1
59		A3222958000	Spring		溝キレバネ	1
60		B3210158000	Bobbin presser		ボビン押エ	1
61		SD0720193-SP	... Hinge screw		" 絞ネジ	1
62		NS6110310-SP	... Nut		" ナット	1
63		B3215232000	Bobbin winder friction wheel		糸巻摩擦車	1
64		SS8151280-SP	... Screw		" "止ネジA	1
65		SS8150710-SP	... Screw		" "B	1

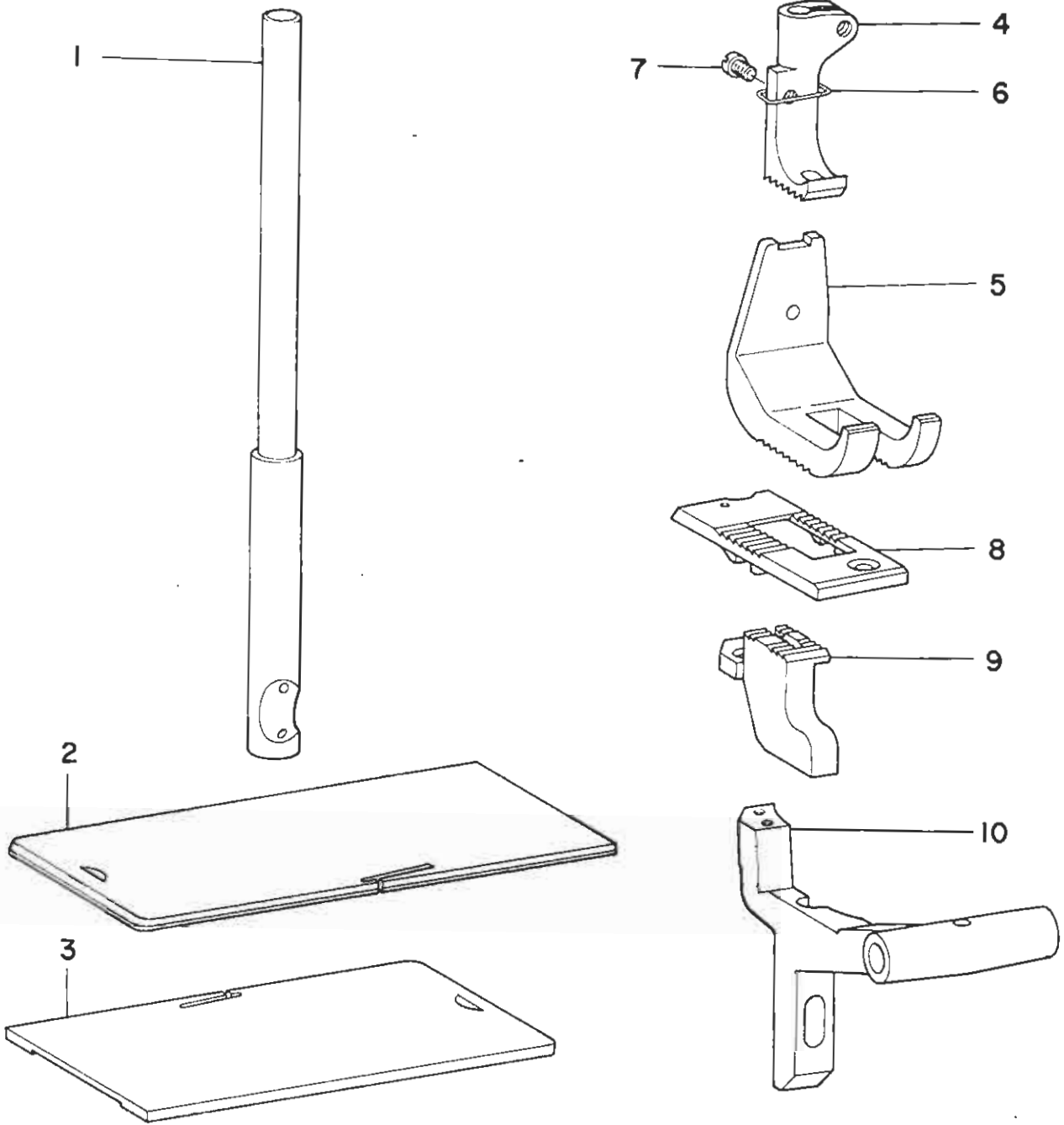

MDEL LG-158-1

7. EXCLUSIVE PARTS FOR LG-158-1			LG-158-1 専用部品			
Ref.No.	Note 注記	Part No. 品番	Description	E. C. 変更年月	品名	Amt. Req. 個数
1		D1401057A0B	Needle bar		針棒 (一本針用)	1
2		B1112057M00	Bed slide, left		送り板 (左)	1
3		D1113057A00	Bed slide, right		送り板 (右)	1
4		D1470158A00	Walking foot		押エ中足	1
5		D1525057A00	Presser foot		押エ足	1
6		D1419158A00	Needle guard		針安全カバー	1
7		S57080520-SP	... Screw		止ネジ	1
8		D1109057A00			針板 (一本針用)	1
9		D1613057A00			送り	1
10		D1602057A00A			送り台	1

[注] 上記以外の部品はすべてLG-158機種と共通です。

(Note) All other parts besides above are in common use with Model LG-158.

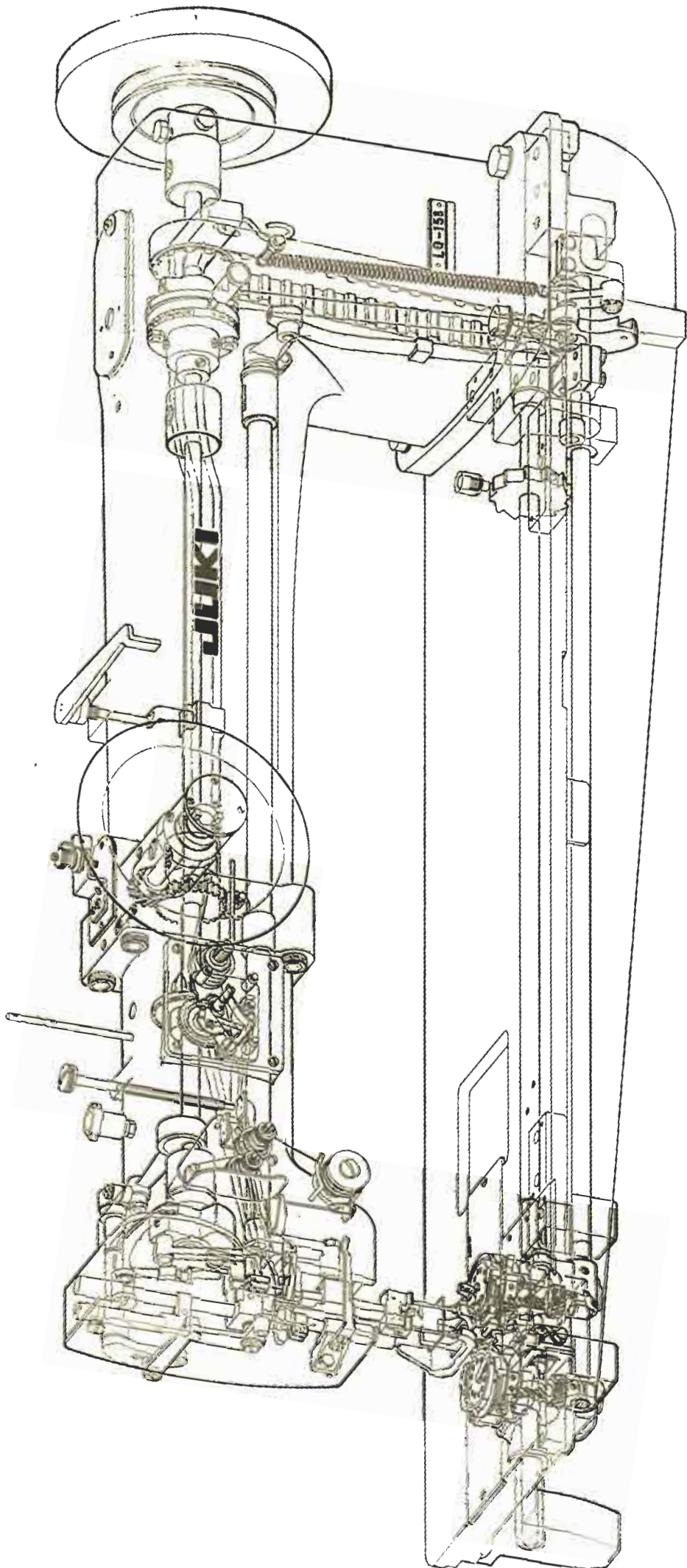



JUKI®
TOKYO JUKI INDUSTRIAL CO., LTD.
Business Office : Kabuki-cho, Shinjuku-ku, Tokyo, Japan
Cable Address : JUKI TOKYO
Telex : 22967 JUKITK
Telephone : Tokyo 203-8241

東京重機工業株式会社

営業本部・東京都新宿区東島4-23 TEL.(203)8241(大代)
本社工場・東京都調布市[原宿町]8-2 TEL.(480)1111(大代)