

**FIRST  
EDITION**

*Union Special*<sup>®</sup>  
INDUSTRIAL SEWING EQUIPMENT

**CATALOG NO. 103X**

---

---

**STYLES**

**39500X**

---

---

**STREAMLINED  
HIGH SPEED OVERSEAMERS**



Catalog No. 103 X  
(Supplement to Catalog No. 103 R)

INSTRUCTIONS  
FOR  
ADJUSTING AND OPERATING

LIST OF PARTS

CLASS 39500

Style

39500 X

First Edition

© 1959

by

Union Special Corporation  
Rights Reserved in All Countries

**UNION SPECIAL CORPORATION**

INDUSTRIAL SEWING MACHINES

**CHICAGO**

Printed in U.S.A.

October, 1977

## IDENTIFICATION OF MACHINE

Each UNION SPECIAL machine carries a Style number which is stamped in the name plate on the machine. Style numbers are classified as standard and special. Standard Style numbers have one or more letters suffixed, but never contain the letter "Z". Example: "Style 39500 X". Special Style numbers contain the letter "Z". When only minor changes are made in a standard machine, a "Z" is suffixed to the standard Style number. Example: "Style 39500 XZ".

Styles of machines similar in construction are grouped under a Class number, which contains no letters. Example: "Class 39500".

## APPLICATION OF CATALOG

This catalog is a supplement to Catalog No. 103 R and should be used in conjunction therewith. Only those parts which are used on Style 39500 X and not on Style 39500 N are illustrated and listed at the back of the book.

This catalog applies specifically to the standard Styles of machines as listed herein. It can also be applied with discretion to some special machines in Class 39500. All references to directions, such as right and left, front and back, etc., are taken from the operator's position while seated at the machine. Operating direction of handwheel is away from operator.

## STYLES OF MACHINES

Single Curved Blade Needle, Two Looper, Three Thread, Overseaming Machine. Plain Feed, Trimming Mechanism with Spring Pressed Lower Knife, Automatic Lubricating System.

39500 X For simultaneously attaching right pants flies and zipper tapes to pants fronts; also attaching zippers to right flies only and similar operations. Seam specification 504-SSa-1 or 504-SSj-1, standard seam width 3/8 inch; stitch range 6 to 16 per inch, standard setting 10 per inch.

## OILING

**CAUTION!** Oil was drained from machine when shipped, so reservoir must be filled before beginning to operate. Oil capacity of Class 39500 is eight ounces. A straight mineral oil of a Saybolt viscosity of 90 to 125 seconds at 100° Fahrenheit should be used.

Machine is filled with oil at spring cap in top cover. Oil level is checked at sight gauge on front of machine. Red bulb on oil level indicator should show between gauge lines.

Machine is automatically lubricated. No oiling is necessary, other than keeping main reservoir filled. Check oil daily before the morning start; add oil as required.

Drain plug screw is located at back of machine near bottom edge of base. It is a magnetic screw designed to accumulate possible foreign materials which may have entered the crank case. It should be removed and cleaned periodically.

## NEEDLES

Each UNION SPECIAL needle has both a type and size number. The type number denotes the kind of shank, point, length, groove, finish and other details. The size number, stamped on the needle shank, denotes largest diameter of blade, measured in thousandths of an inch, midway between the shank and the eye. Collectively, the type and size number represent the complete symbol which is given on the label of all needles packaged and sold by Union Special.

Style 39500 X uses curved blade needles. The standard needle for this style is Type 154 GAS. It has a round shank, round point, curved blade, standard length, single groove, struck groove, spotted, chromium plated and is available in sizes - 055/022, 065/025, 070/027, 075/029, 080/032, 090/036, 100/040, 110/044, 125/049, 140/054, 150/060.

To have needle orders promptly and accurately filled, an empty package, a sample needle, or the type and size number should be forwarded. Use description on label. A complete order would read: "1000 Needles, Type 154 GAS, Size 090/036".

Selection of proper needle size is determined by size of thread used. Thread should pass freely through needle eye in order to produce a good stitch formation.

Success in the operation of UNION SPECIAL machines can be secured only by use of needles packaged under our brand name, *Union Special*, which is backed by a reputation for producing highest quality needles in materials and workmanship for more than three-quarters of a century.

## CHANGING NEEDLES, ETC.

All instructions in regard to Changing Needles, Thread Stand, Threading, are the same as for Style 39500 N covered in Catalog No. 103 R.

## ASSEMBLING AND ADJUSTING SEWING PARTS

All the instructions pertaining to the adjustment of Style 39500 X are the same as those for Style 39500 N illustrated in Catalog No. 103 R except for the following:

1. Under the heading "SETTING THE NEEDLE", the height of the needle above the throat plate for Style 39500 X should be  $15/32$  inch instead of  $1/2$  inch.
2. Under the same heading, in paragraph three, the looper gauge for Style 39500 X should be  $3/32$  inch instead of  $1/8$  inch, and looper gauge No. 21225- $3/32$  should be used.

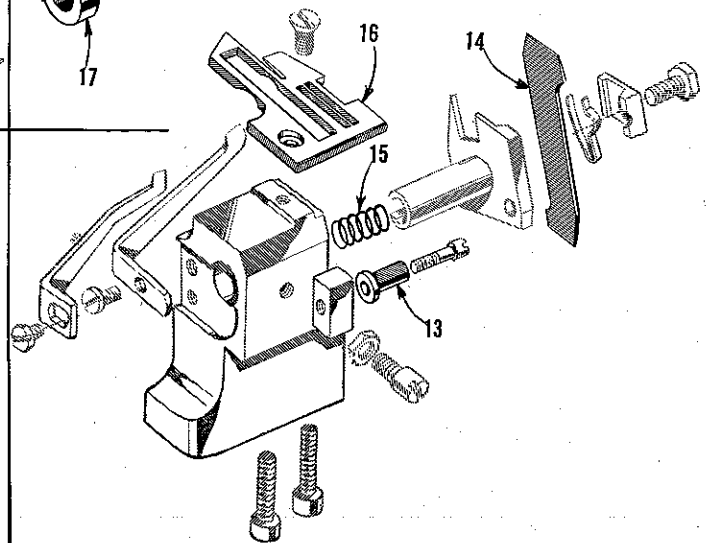
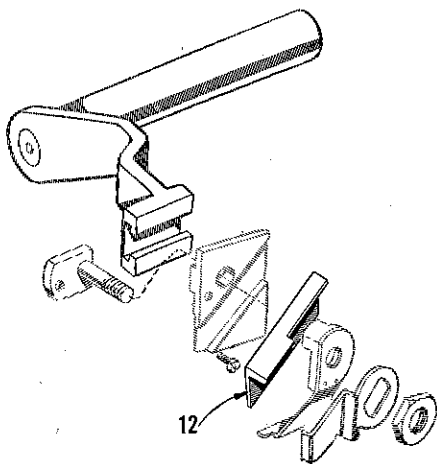
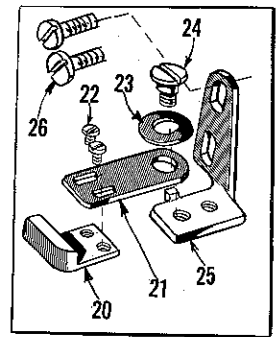
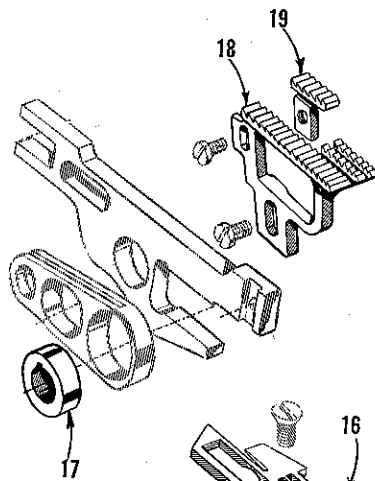
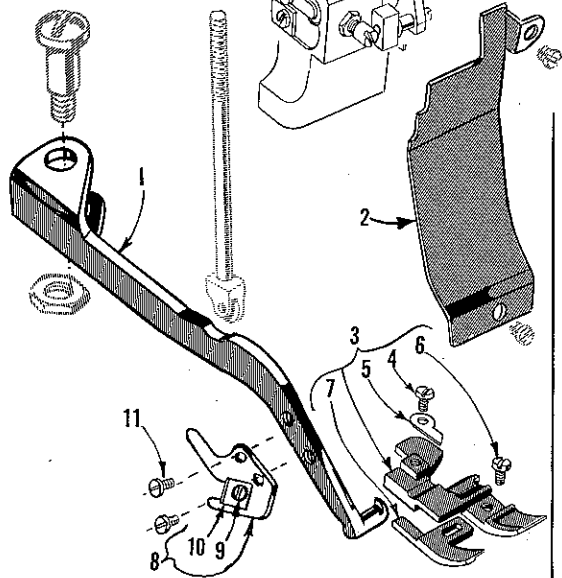
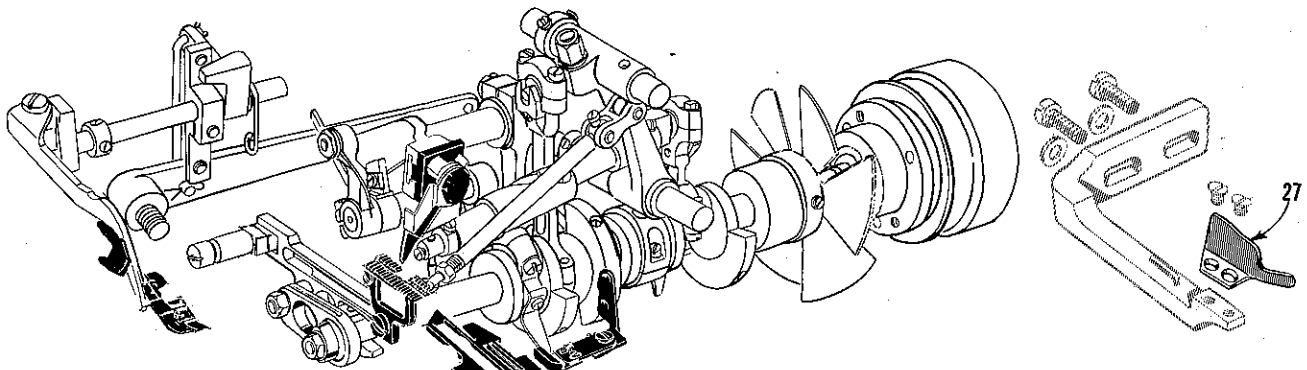

The parts illustrated on the preceding page and described on this page represent the parts that are used on Style 39500 X, but not used on Style 39500 N.

Those parts shown in phantom views and bearing no reference numbers are common to Styles 39500 X and 39500 N.

Use Catalog No. 103 R for all parts not illustrated or described here.

<u>Ref. No.</u>	<u>Part No.</u>	<u>Description</u>	<u>Amt. Req.</u>
1	39556 D	Presser Foot Arm-----	1
2	39578 BA	Chip Guard -----	1
3	39520 FX	Presser Foot -----	1
4	87 U	Screw -----	1
5	39530	Hinge Spring -----	1
6	28	Screw -----	1
7	39530 AB	Guide, marked "S" -----	1
8	39556 M	Chain Cutting Knife, complete -----	1
9	22798	Screw -----	1
10	39556 L	Chain Cutting Knife -----	1
11	605	Screw -----	2
12	39570 J	Upper Knife-----	1
13	39550 R	Lower Knife Holder Locating Stud -----	1
14	39549 J	Lower Knife -----	1
15	39550 P	Knife Holder Spring-----	1
16	39524 X	Throat Plate, marked "AR" -----	1
17	39540 B-10	Main Feed Driving Eccentric, .022 inch throw---	1
18	39505 X	Main Feed Dog -----	1
19	39505 M	Chaining Feed Dog, marked "Y" -----	1
20	39503 A	Edge Guide, adjustable-----	1
21	39503 D	Edge Guide Swinging Arm -----	1
22	604	Screw -----	2
23	12957 E	Washer-----	1
24	22758 E	Screw -----	1
25	39503 C	Edge Guide Mounting Bracket -----	1
26	22569 C	Screw -----	2
27	39578 S	Fabric Guard -----	1

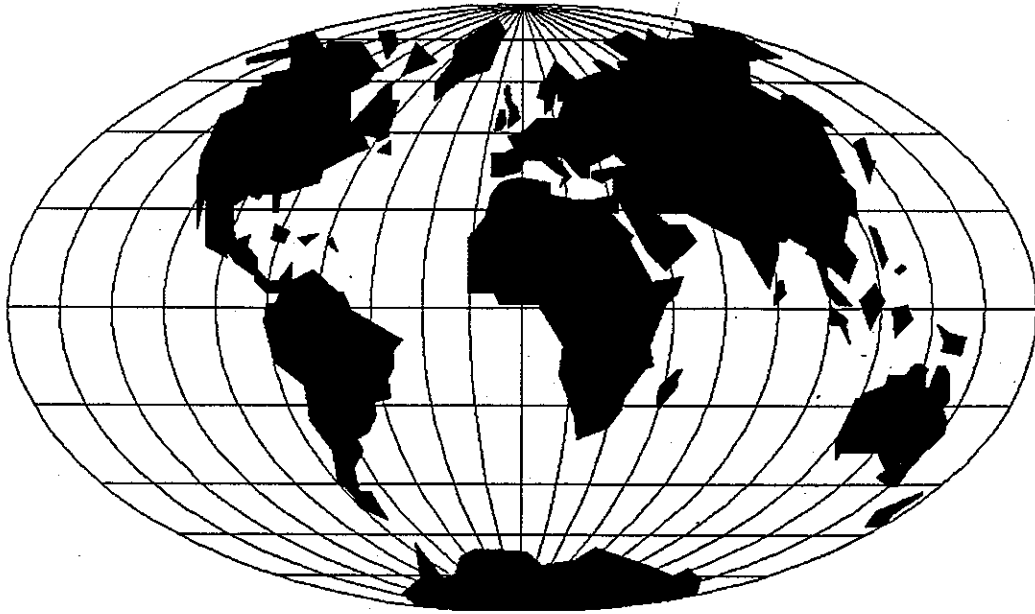

## WORLDWIDE SALES AND SERVICE

Union Special Corporation maintains sales and service facilities throughout the world. These offices will aid you in the selection of the right sewing equipment for your particular operation. Union Special Corporation representatives and service technicians are factory trained and are able to serve your needs promptly and efficiently. Whatever your location, there is a qualified representative to serve you.

---

Brussels, Belgium  
Charlotte, N.C.  
El Paso, TX  
Hong Kong, China  
Huntley, IL  
Leicester, England  
Lille, France  
Miami, FL  
Milan, Italy  
Möglingen, Germany  
Montreal, Quebec  
Osaka, Japan  
Santa Fe Springs, CA

Other Representatives throughout  
all parts of the world.

  
Finest Quality

**JUKI**  
*Union Special*