

# mitsubishi

## 三菱工業用ミシン部品カタログ

## Industrial Sewing Machine Parts Catalog

Model PLK-E1010

	目次	CONTENTS	Page
A	本体構成	Construction .....	1
B	本体関係(1)	Arm bed & it's accessories (1) .....	2
C	本体関係(2)	Arm bed & it's accessories (2) .....	4
D	縫い機構(1)	Sewing mechanism (1) .....	6
E	縫い機構(2)	Sewing mechanism (2) .....	8
F	X-Yテーブル機構(1)	X-Y table mechanism (1) .....	10
G	X-Yテーブル機構(2)	X-Y table mechanism (2) .....	12
H	外押え機構(1)	Work holder mechanism (1) .....	14
J	外押え機構(2)	Work holder mechanism (2) .....	16
K	糸切り機構	Thread trimming mechanism .....	18
L	中押え機構	Presser bar lifting mechanism .....	20
M	ワイパー機構	Wiper mechanism .....	22
N	給油機構	Oil lubrication mechanism .....	24
P	配線検出器関係	Cable component & Detector mechanism .....	26
Q	テーブル関係	Table & Stand .....	28
R	付属品(1)	Accessories (1) .....	30
S	付属品(2)	Accessories (2) .....	32
T	オプションパーツ	Option parts .....	34
	索引	Index .....	36

## 部品コードの採番形式

### MITSUBISHI SPARE PARTS No. Designation system

#### 1. 部品コードについて CONCERNING PARTS CODE.

部品をご注文される場合は、部品コードをお知らせください。

Please inform the part number, when these parts are ordered.

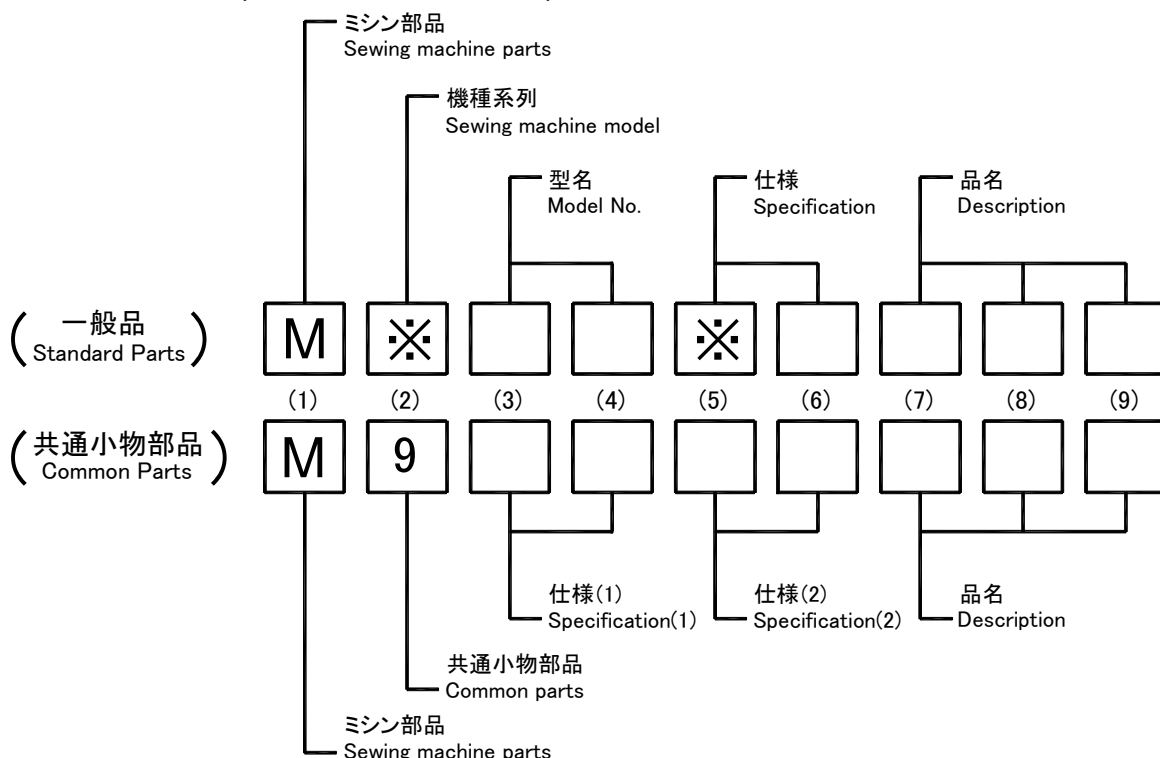

[ 例 ]  
Example

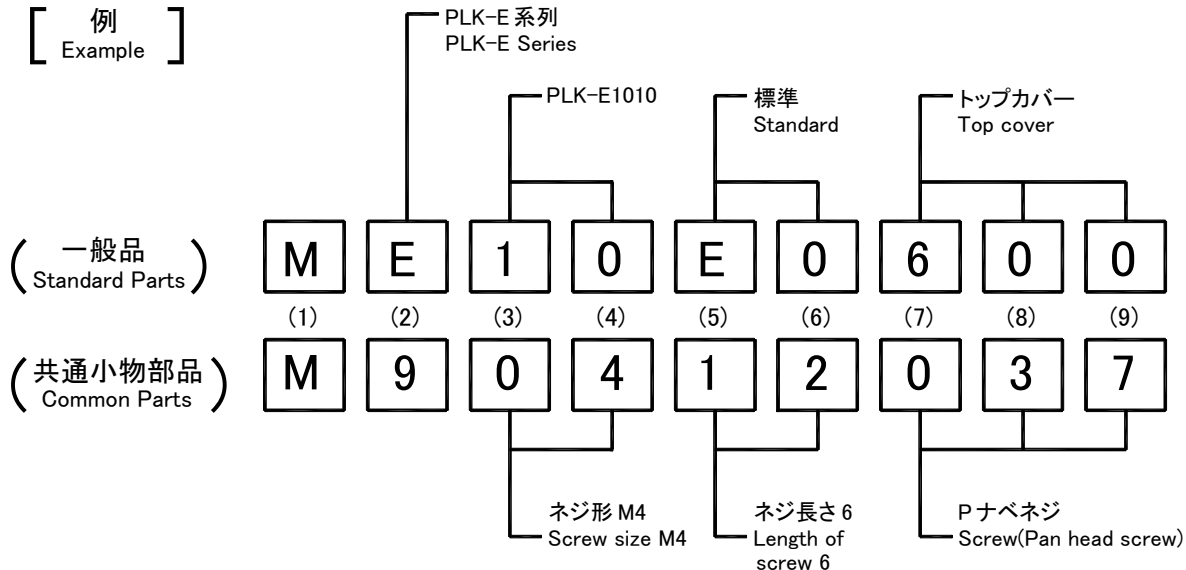

#### 2. 変更マークについて CONCERNING MODIFICATION MARK.

変更マーク欄に\*記号のある部品は、形状、寸法などの変更履歴がありますので、ご注文の際にはご使用の製品の製造番号と合わせてご覧ください。

The parts marked with \* in the modification column has been changed the shape or size etc. So when these modified parts are ordered please inform the serial number of the sewing machine.

注: 一般品についての機種型名は、その部品が最初に使用された機種型名を示します。

従って長期にわたる場合は、機種の変更が行われるため、当初の機種以外の機種で使用されている場合があります。

Sewing machine Models, of Standard Parts are Indicated model of these parts are registered firstly. Parts are used for not only the indicated model, but also another models, in reason of New development, improvement after.

**A** 全体構成  
CONSTRUCTION

---

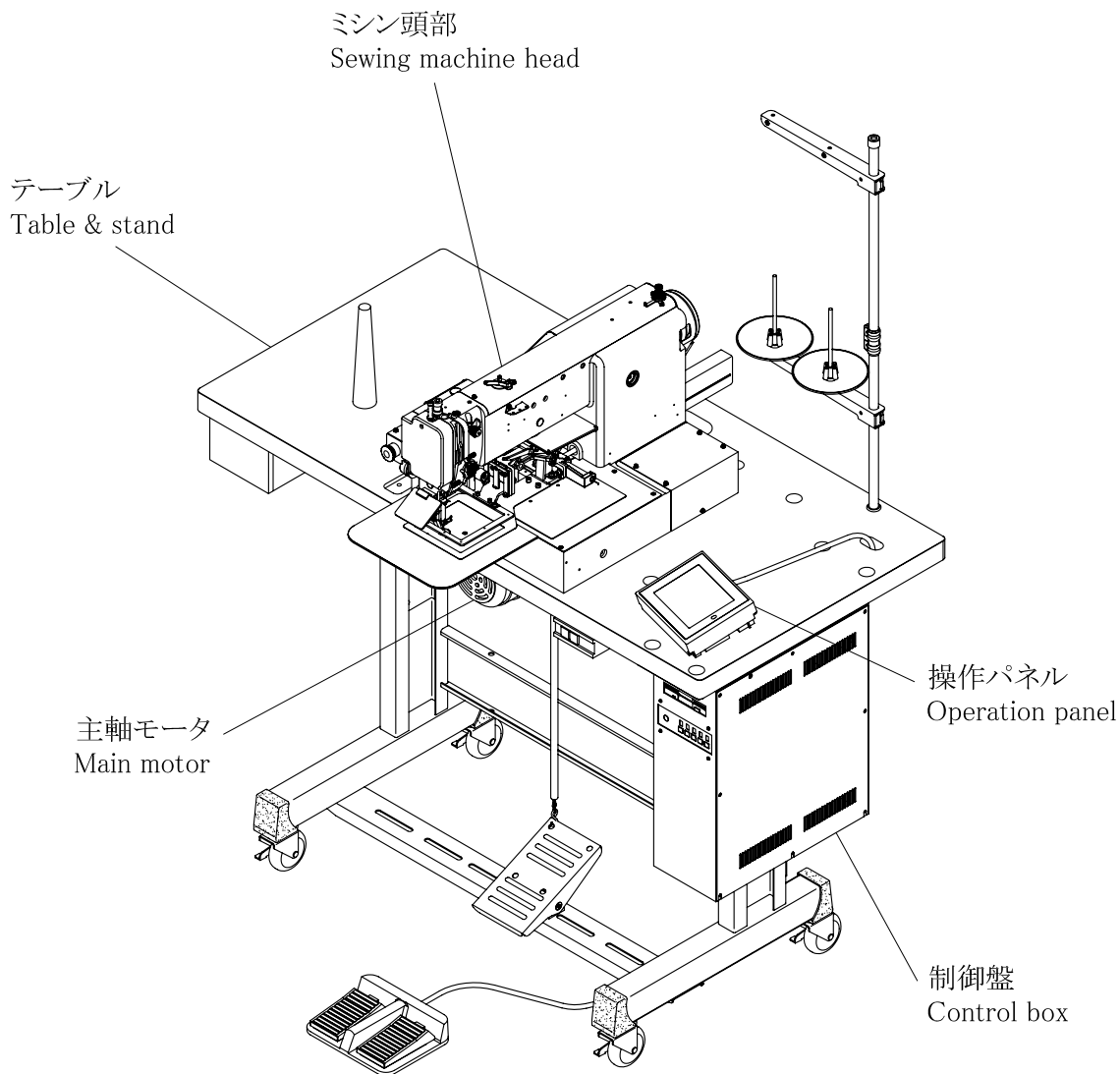

注1：モータ部分は三菱リミサーボX部品カタログを参照ください。

注2：Fig.No.の採番していない部品は単体で支給することは出来ません。Setにて支給いたします。

Remarks 1) Concerning about the motor parts please refer to the parts catalog of MITSUBISHI LIMI SERVO X.

Remarks 2) The parts which Fig.No are not marked are not available individually. It can be supplied with the whole component.

**B** 本体関係(1)  
ARM BED & IT'S ACCESSORIES(1)

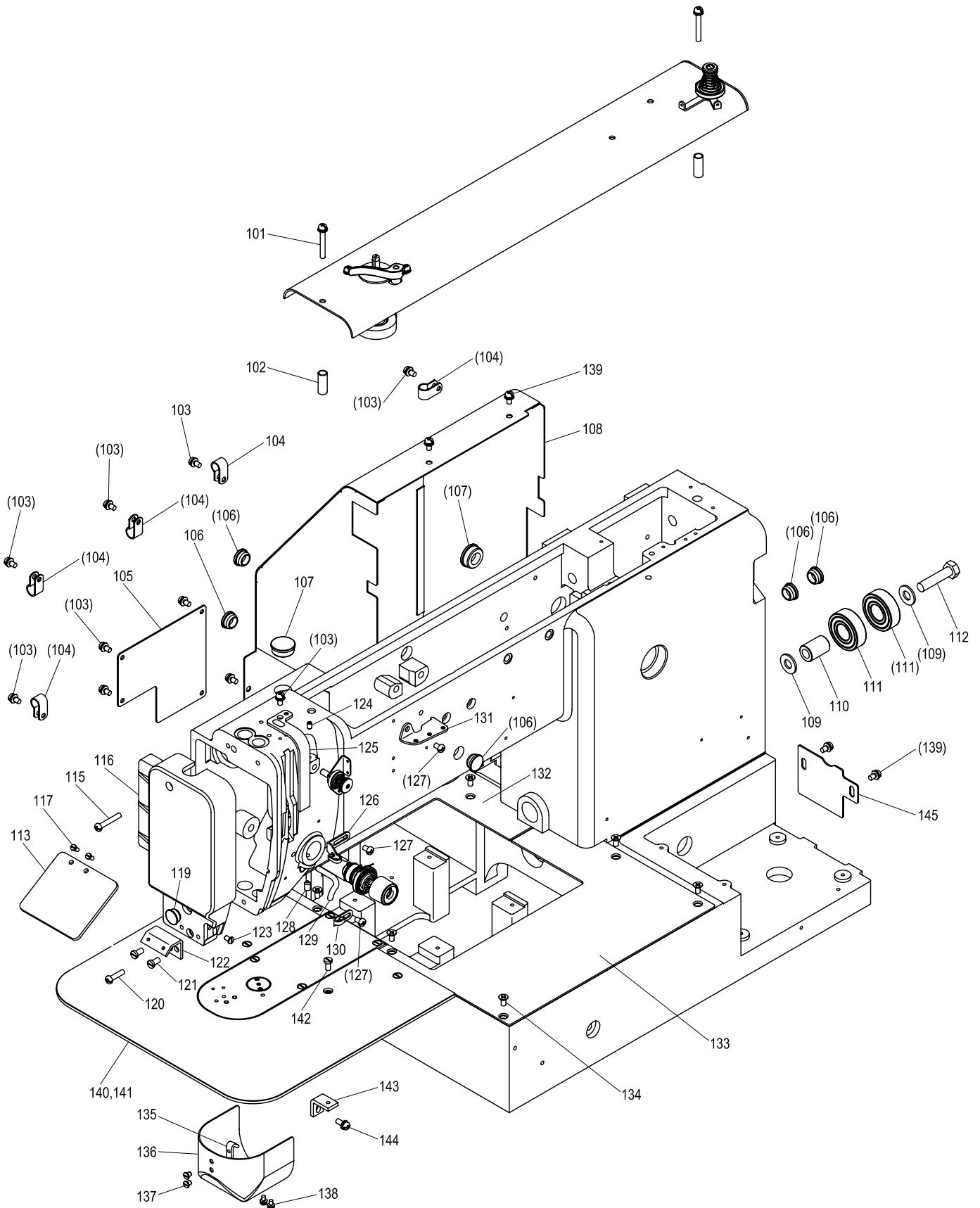

[B]本体関係(1)

ARM BED & IT'S ACCESSORIES (1)

Fig no.	変更 Mod.	部品コード Parts no.	品名	Description	数量 Amt. Req.
B 101		M91276004	SW-PWﾌﾟﾗﾏｲﾅﾍﾞﾈｼﾞ M4X30	Screw M4X30	2
B 102		MB62A0352	ｽﾍﾟｰｻ 1382312-60200	Spacer	2
B 103		M91054004	SW-PWﾌﾟﾗﾏｲﾅﾍﾞﾈｼﾞ M4X8	Screw M4X8	10
B 104		MN60A0620	ﾅｲﾛﾝｸﾘｯﾌﾟ AB-5N	Nylon clip AB-5N	5
B 105		ME10A0742	ﾌﾀ	Cover	1
B 106		M91304080	ｺﾞﾑｾﾝ φ13	Rubber plug φ13	5
B 107		M91910080	ｺﾞﾑｾﾝ φ19	Rubber plug φ19	2
B 108		ME10E0849	ﾓｰﾀｶﾊﾞｰ	Motor cover	1
B 109		M90823050	ﾐｶｷﾞｻﾞｶﾞﾈ 8	Washer 8	2
B 110		MB60A0750	ﾌﾞｯｼﾞ	Bushing	1
B 111		MS10A1456	ｼﾞｸﾞｳｹ 6202ZZ	Bearing	2
B 112	C	M91803022	ﾛｯｶｸﾞｱﾅｯﾂｷﾎﾙﾄ M8X40	Bolt M8X40	1
B 113		MS01A0160	ｱｲｶﾞｰﾄﾞ	Eye guard	1
B 115	C	M91066004	SW-PWﾂｷﾌﾟﾗﾏｲﾅﾍﾞﾈｼﾞ M4X25	Screw M4X25	1
B 116	B	ME10E1830	ﾒﾝｲﾀ	Face cover	1
B 117		M90806002	ﾋﾗﾈｼﾞ 1/8(44)X6	Screw 1/8(44)X6	2
B 118					
B 119		M91180080	ｺﾞﾑｾﾝ φ11.8	Rubber plug φ11.8	1
B 120	C	M91057004	SW-PWﾂｷﾌﾟﾗﾏｲﾅﾍﾞﾈｼﾞ M4X20	Screw M4X20	1
B 121		M91110002	ﾋﾗﾈｼﾞ 11/64(40)X8	Screw 11/64(40)X8	2
B 122		MB60A0601	ｱｲｶﾞｰﾄﾞﾄﾘｯｹｲﾀ	Eye guard bracket	1
B 123		M90908003	ﾏﾙﾋﾗﾈｼﾞ 9/64(40)X6	Screw 9/64(40)X6	1
B 124		M91053020	ﾛｯｶｸﾞｱﾅｯﾂｷﾄﾒﾈｼﾞ M4X6	Screw M4X6	1
B 125		MA20A0584	ﾃﾞﾝﾋﾞﾝｶﾊﾞｰ	Thread take-up lever guard	1
B 126		MG43A0181	ｲﾄｱﾝﾅｲ	Thread guide	1
B 127		M91011004	ﾌﾟﾗﾏｲﾅﾍﾞﾈｼﾞ M4X6	Screw M4X6	3
B 128		M95004020	ﾛｯｶｸﾞｱﾅｯﾂｷﾄﾒﾈｼﾞ M5X8	Screw M5X8	1
B 129		MF70A1180	ｲﾄｱﾝﾅｲ	Thread guide	1
B 130		MF10A0181	ｲﾄｱﾝﾅｲ	Thread guide	1
B 131		MF36A1180	ｲﾄｱﾝﾅｲ	Thread guide	1
B 132		ME10A0339	X ｶﾊﾞｰｲﾀ (L)	X Cover plate (L)	1
B 133		ME10A1339	X ｶﾊﾞｰｲﾀ (R)	X Cover plate (R)	1
B 134		M91400010	Pｻﾗﾈｼﾞ M4X8	Screw M4X8	8
B 135		MS01A0361	ｶﾞｶﾞﾈ	Latch	1
B 136	C	ME10B0339	ｼﾘﾝﾀｰｶﾊﾞｰ	Cylinder cover	1
B 137		M90906003	ﾏﾙﾋﾗﾈｼﾞ 9/64(40)X3.2	Screw 9/64(40)X3.2	2
B 138		M90859004	SW-PWﾌﾟﾗﾏｲﾅﾍﾞﾈｼﾞ M3X6	Screw M3X6	2
B 139	B	M91071004	SW-MWﾌﾟﾗﾏｲﾅﾍﾞﾈｼﾞ M4X8	Screw M4X8	6
B 140	B	ME10A1470	ｽﾍﾟﾘｲﾀ(ｯﾄ)	Slide plate (outside)	1
B 141	B	ME10A0797	ﾎｺﾞﾌｲﾙﾑ	Film sheet	1
B 142	B	M90990002	ﾋﾗﾈｼﾞ M4X8	Screw M4X8	4
B 143	B	MB62A4601	ﾄﾘｯｹｲﾀ	Adapter	4
B 144	B	M91013004	SW-MWﾌﾟﾗﾏｲﾅﾍﾞﾈｼﾞ M4X10	Screw M4X10	4
B 145	B	ME03A8339	ｶﾊﾞｰ	Cover	1

C 本体関係(2)  
 ARM BED & IT'S ACCESSORIES(2)

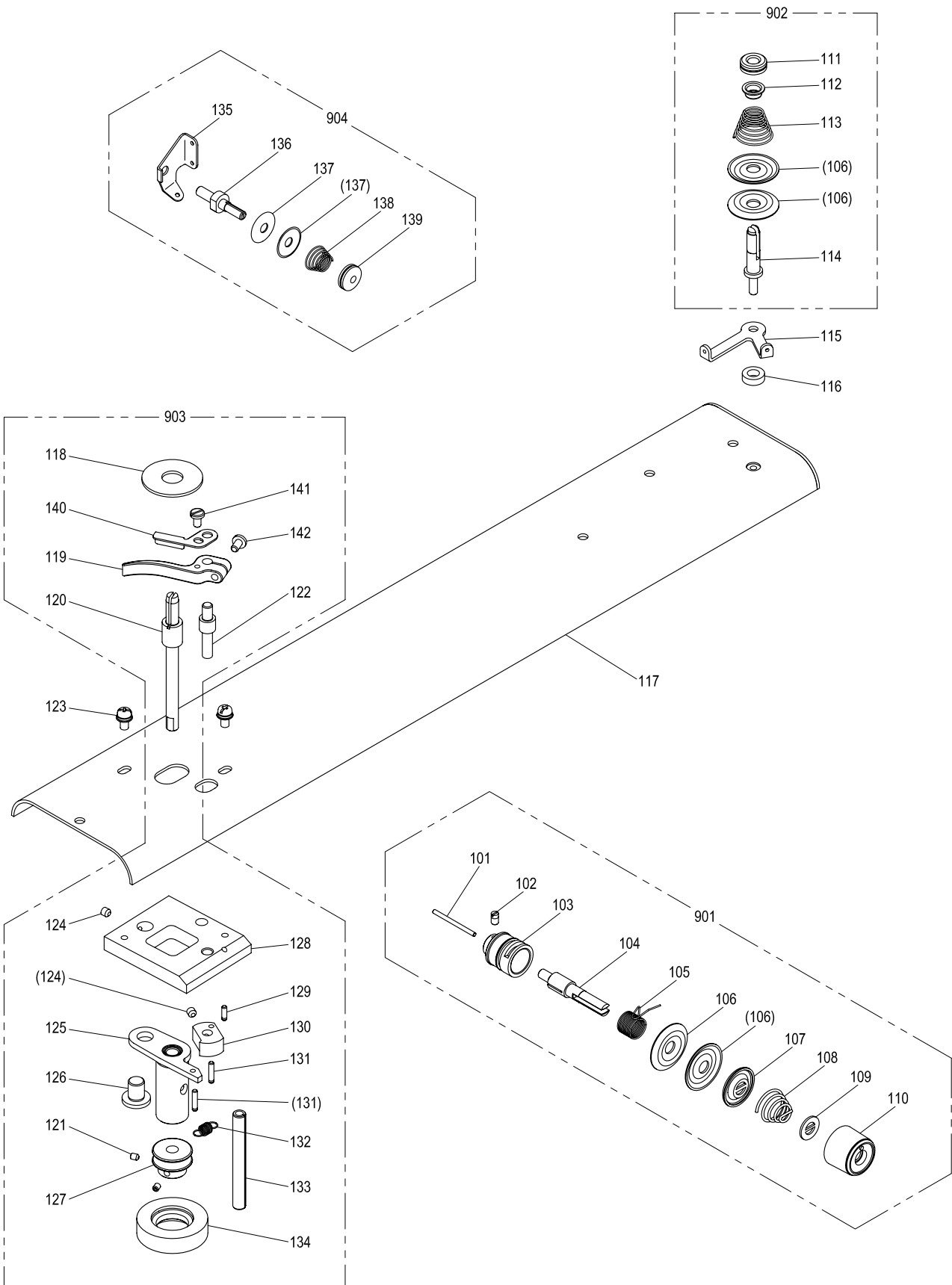

[C]本体関係(2)

ARM BED & IT'S ACCESSORIES(2)

Fig no.	変更 Mod.	部品コード Parts no.	部品名	Description	数量 Amt. Req.
C 101		M90204060	ピン	Pin	1
C 102		M90901002	ヒラネジ 9/64(40)X4	Screw 9/64(40)X4	1
C 103		MF10A0709	ブッシュ	Regulator casing	1
C 104		MF10A0553	チョウシホウ	Thread tension stud	1
C 105		MF10A0187	イトリハネ	Thread take-up spring	1
C 106		MF10A0555	チョウシザラ	Thread tension discs	4
C 107		MM11A0556	チョウシザラオサエ	Disc retaining plate	1
C 108		MN52A1245	エンスイハネ	Thread tension spring	1
C 109		MT60A0802	マワリドメ	Thumb nut revolution stopper	1
C 110		M91605045	ツマミナット	Thumb nut	1
C 111		M91602046	ツマミナット	Thumb nut	1
C 112		MM11A0702	ハネアンナイ	Spring guide	1
C 113		MM11A0245	エンスイハネ	Thread tension spring	1
C 114		MS14A0553	チョウシホウ	Thread tension stud	1
C 115		MS14A0180	イトアンナイ	Thread guide	1
C 116		MG75A1476	スペーサー	Spacer	1
C 117		ME10E0600	トップカバー	Top cover	1
C 118		MA20A0476	スペーサー	Spacer	1
C 119	B	ME25A0950	レバー	Lever	1
C 120		MA04A1530	ダンツクシク D	Driven shaft	1
C 121		M91057020	ロッカクアナツキトメネジ M3X4	Screw M3X4	2
C 122	C	ME25A0530	ダンツクシク	Shaft	1
C 123	B	M91013004	SW-MWプラマイナヘネジ M4X10	Screw M4X10	2
C 124		M91055020	ロッカクアナツキトメネジ M4X4	Screw M4X4	2
C 125		MB60E0950	レバークミタテ	Lever	1
C 126		M99006063	ピン	Pin	1
C 127		MA20A0194	イマキグルマ	Wheel	1
C 128		MB60A1601	トリツケイタ	Bracket	1
C 129		M91004067	ミゾツキピン BXガタ φ2.5X8	Pin φ2.5X8	1
C 130		MS14A0350	カム	Cam	1
C 131		M91005067	ミゾツキピン BXガタ φ2.5X12	Pin φ2.5X12	2
C 132		MS14A0572	ツルマキハネ	Spring	1
C 133		M90601064	スプリングピン φ6X56	Pin φ6X56	1
C 134		MS03A0417	ゴムワ	Tire	1
C 135		MF00A0181	イトアンナイ	Thread guide	1
C 136		MF00A0553	チョウシホウ	Thread tension stud	1
C 137		MF10A1555	チョウシザラ	Thread tension discs	2
C 138		MF36A0245	エンスイハネ	Thread tension spring	1
C 139		M91101046	ツマミナット	Thumb nut	1
C 140	B	ME25A0551	チョウセツイタ	Adjuster plate	1
C 141	B	M90920002	ヒラネジ 9/64(40)X6.5	Screw 9/64(40)X6.5	1
C 142	B	M90939002	ヒラネジ 9/64(40)X11	Screw 9/64(40)X11	1
C 901		MA16E0210	チョウセツクミタテ	Thread tension Regulator assy	1
C 902		MS14E0180	チョウセツクミタテ	Thread tension Regulator assy	1
C 903	C	ME25E0190	イマキソウチクミタテ	Bobbin winder	1
C 904		MF00E0550	チョウセツクミタテ	Thread tension Regulator assy	1

**D** 縫い機構(1)  
SEWING MECHANISM(1)

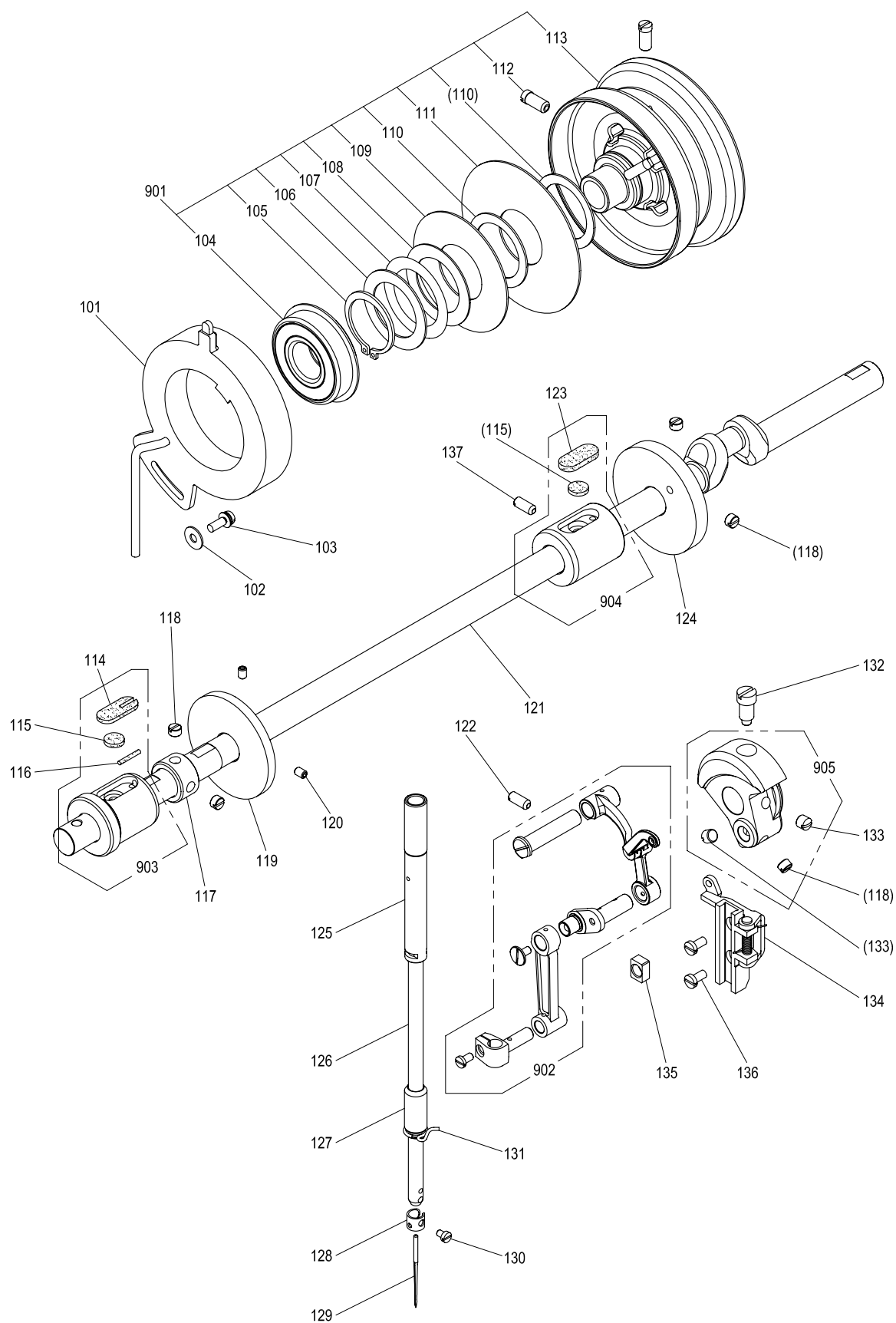



## [D]縫い機構(1)

## SEWING MECHANISM (1)

Fig no.	変更 Mod.	部品コード Parts no.	品名	Description	数量 Amt. Req.
D 101	C	ME20A0406	ウワジクセンシュツキ	Detector	1
D 102	B	M90421050	ザガネ 4	Washer 4	1
D 103	B	M91059004	SW-PWフライナハネジ M4X12	Screw M4X12	1
D 104		MN10A1456	ボールベアリング	Ball bearing	1
D 105		M90330065	Cガ外ワ 30	C-type retaining ring 30	1
D 106		M93001050	ザガネ	Washer	1
D 107		MF01A0259	ナミザガネ	Wave washer	1
D 108		MF01A1476	スペーサー B	Spacer B	1
D 109		MN72A1694	ハンシャパン F20 (ウワイチ)	Command disk F20 (up)	1
D 110		MF01A0476	スペーサー A	Spacer A	2
D 111		MB60A0694	ハンシャパン K10 (シタイチ)	Command disk K10 (down)	1
D 112		M91520002	ヒラネジ 15/64(28)X12	Screw 15/64(28)X12	2
D 113		MB60E0682	プーリー	Pulley	1
D 114		MG50A0740	フェルト	Felt	1
D 115		MS10A1740	フェルト	Felt	2
D 116		MV88A0740	フェルト	Felt	1
D 117		MF70A0352	カラー	Collar	1
D 118		M91602001	トメネジ 1/4(40)X4	Screw 1/4(40)X4	5
D 119		MS14A0682	イトマキプーリー	Pulley	1
D 120		M91053020	ロックアナツキトメネジ M4X6	Screw M4X6	2
D 121		ME10A0230	ウワジク	Drive shaft	1
D 122		M91221001	トメネジ M5X12	Screw M5X12	1
D 123		MF60A2740	フェルト	Felt	1
D 124		MS01A0350	イトキリカム	Thread trimmer cam	1
D 125		MS01A0663	ハリボウメタル (ウエ)	Needle bar bushing (upper)	1
D 126		MS01A0660	ハリボウ	Needle bar	1
D 127		MG30A0664	ハリボウメタル (シタ)	Needle bar bushing (lower)	1
D 128		MF21D0181	イトアンナイ	Thread guide	1
D 129		MS02A0128	ミシンハリ DPX17#18	Needle DPX17#18	1
D 130		M90815002	ヒラネジ 1/8(44)X4.5	Screw 1/8(44)X4.5	1
D 131		MF01A0181	イトアンナイ	Thread guide	1
D 132		M91802006	ヒラネジボウサキ 9/32(28)	Set screw 9/32(28)	1
D 133		M91606001	トメネジ 1/4(40)X6	Screw 1/4(40)X6	2
D 134		MS03E0662	ハリカガイドクミタテ	Guide assy	1
D 135		MF10A0325	カクコマ	Square block	1
D 136		M90990002	ヒラネジ M4X8	Screw M4X8	2
D 137	B	M91223001	トメネジ M5X10	Screw M5X10	1
D 901		MB60E1682	プーリークミタテ	Pulley assy	1
D 902		MS01E0580	テンビンハリクミタテ	Thread take-up lever assy	1
D 903		MS10A0232	ウワジクメタル(ヒタリ)クミ	Drive shaft bushing L assy	1
D 904		MB60E0234	ウワジクメタル(ナカ)クミ	Drive shaft bushing C assy	1
D 905		MS01A0383	クランククミ	Crank assy	1

E 縫い機構(2)  
SEWING MECHANISM(2)

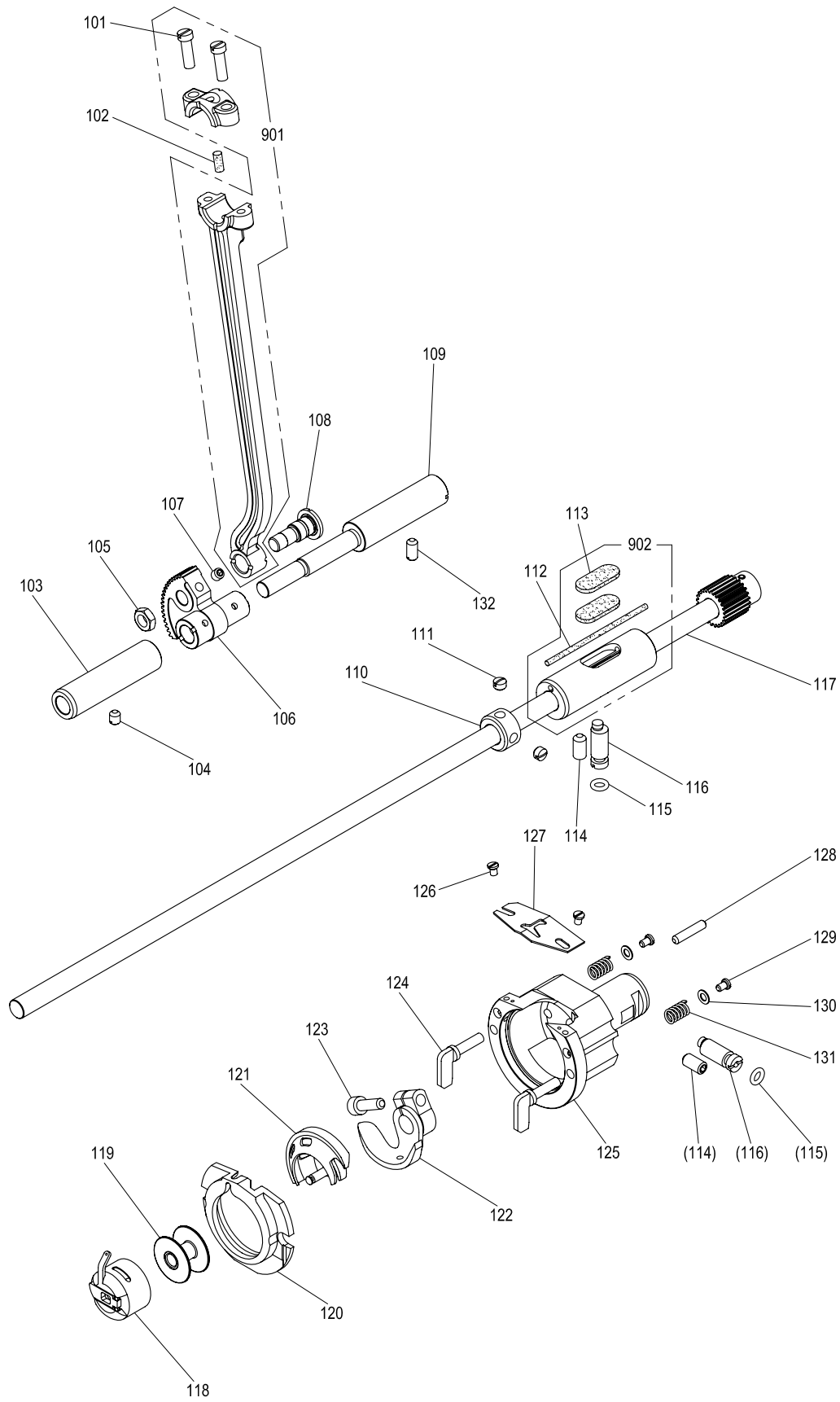

## [E]縫い機構(2)

## SEWING MECHANISM (2)

Fig no.	変更 Mod.	部品コード Parts no.	品名	Description	数量 Amt. Req.
E 101		M91203002	ヒラネジ 3/16(28)X15	Screw 3/16(28)X15	2
E 102		MB60A0740	フェルト	Felt	1
E 103		MS01A0833	メタル	Bushing	1
E 104	B	M91222001	トメネジ M5X6	Screw M5X6	1
E 105		M91802045	ナット 9/32(28)	Nut 9/32(28)	1
E 106		MS01A0508	セクタハグルマ	Sector gear	1
E 107		M95004021	ロックアナツキトメネジ M5X5	Screw M5X5	1
E 108		M98003015	ヒラネジタツキ 9/32(28)	Screw 9/32(28)	1
E 109		MS01A0891	ヨウトウシク	Rock shaft	1
E 110		MM11A0352	カラー	Collar	1
E 111		M91503001	トメネジ 15/64(28)X4.5	Screw 15/64(28)X4.5	2
E 112		ME10A0148	ヒモ	Oil braid	1
E 113		MA20A0740	フェルト	Felt	2
E 114	B	M96002020	ロックアナツキトメネジ M6X12	Screw M6X12	2
E 115		M90500085	O リング	O-ring	2
E 116		MS01A0761	ヘンジンシク	Eccentric shaft	2
E 117		ME10E0450	シタジク クミ	Hook shaft assy	1
E 118		MS17A0125	ホビンケース SC-181	Bobbin case	1
E 119		MA10A0123	ホビン	Bobbin	1
E 120		MS08A0616	ナカガマオサエ	Hook retainer	1
E 121		MA10A0120	ナカガマ	Inner hook	1
E 122		MS01A0611	ドライバ	Hook driver	1
E 123		M95001021	ロックアナツキボルト M5X16	Bolt M5X16	1
E 124		MS09A0950	カマオサエツマミ	Hook clamp	2
E 125		MS01A0121	ソトガマ	Outer hook	1
E 126		M90853002	ヒラネジ 1/8(40)X4	Screw 1/8(40)X4	2
E 127		MS01A0329	カマイトアンナイ	Thread guide	1
E 128		M90001060	ヘイコウピン M6-4X18	Pin M6-4X18	1
E 129		M90802003	マルヒラネジ 1/8(44)X4.5	Screw 1/8(44)X4.5	2
E 130		M93006050	ワシカネ	Washer	2
E 131		MS01A0572	ツルマキハネ	Spring	2
E 132	B	M91221001	トメネジ M5X12	Screw M5X12	1
E 901		MB60E1956	レンセツカン クミ	Connecting rod assy	1
E 902		ME10E0452	シタジクメタル(ミキ)クミ	Hook shaft bushing (R) assy	1

F X-Yテーブル機構(1)  
X-Y TABLE MECHANISM(1)

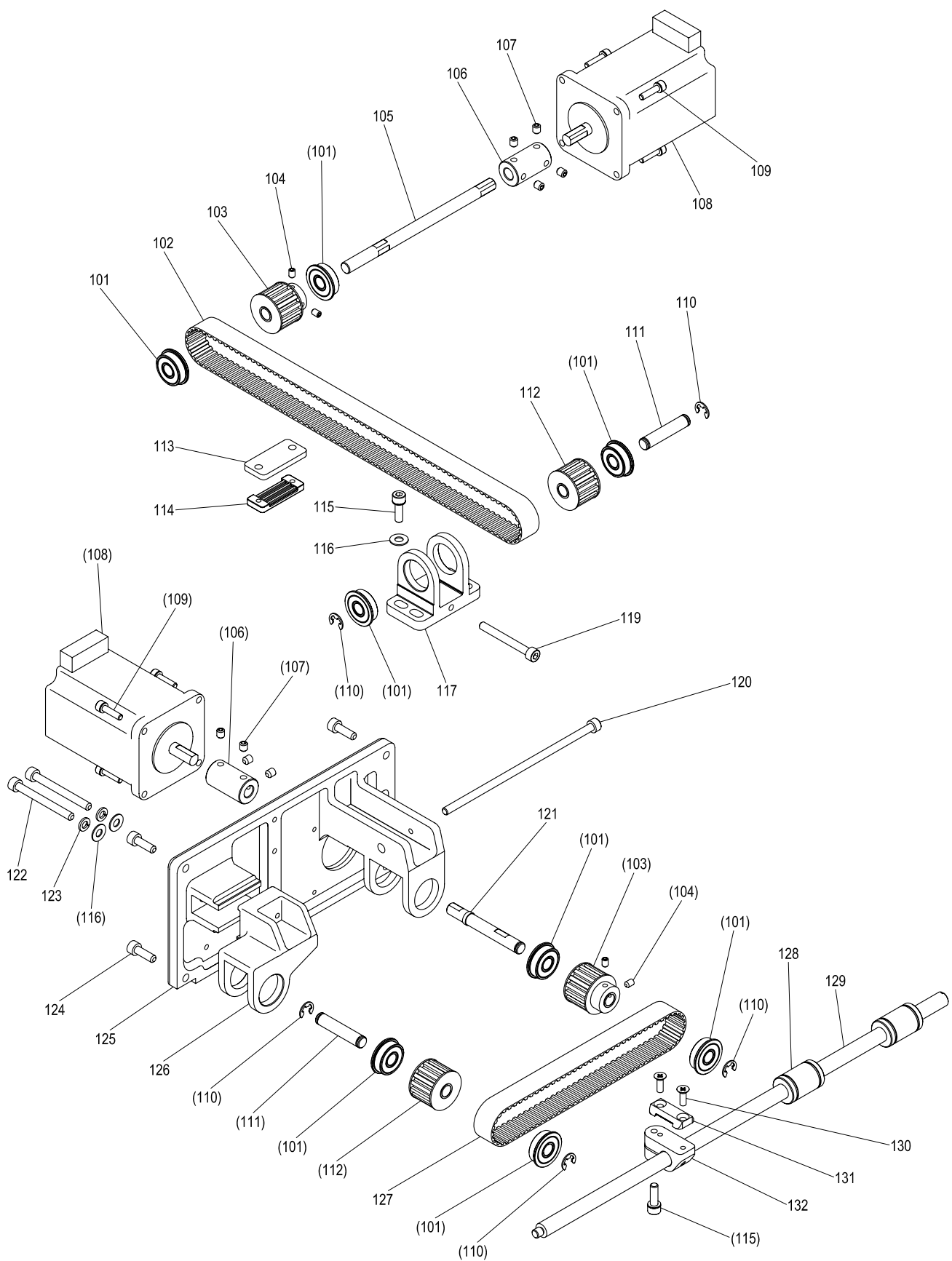

[F]X-Yテーブル機構(1)  
X-Y TABLE MECHANISM (1)

Fig no.	変更 Mod.	部品コード Parts no.	品名	Description	数量 Amt. Req.
F 101		M91001075	ボールベアリング	Ball bearing	8
F 102		MB60A0523	タイミングベルト X	Cog belt X 15T5-630(126Z)	1
F 103		MB60A2682	タイミングプーリ (クドウ)	Driving pulley	2
F 104		M95001001	ナイロケットメネジ M4X6	Screw M4X6	4
F 105		ME10A1390	Xクドウシク	Driving shaft X	1
F 106		ME10A0571	ジクツキテ	Sleeve	2
F 107		M94001001	ナイロケットメネジ M5X6	Screw M5X6	8
F 108		M95060095	ステッピングモータ	Stepping motor	2
F 109		M94006017	セフティソケット M4X16	Bolt M4X16	8
F 110		M90511065	Eカクメワ 6	E-type retaining ring 6	5
F 111		MB60A1454	シク	Shaft	2
F 112		MB60A3682	タイミングプーリ (ジュウトウ)	Driven pulley	2
F 113		MB60A0476	スペーサ	Spacer	1
F 114		MB60A0778	ベルトオサエ X	Belt clamber X	1
F 115		M95004017	セフティソケット M5X16	Bolt M5X16	5
F 116		M90511050	サガネ 5	Washer 5	6
F 117		MB60A1758	ブラケット X	Bracket X	1
F 119		M95035021	ロッカクアナツキホルト M5X45	Bolt M5X45	1
F 120		M95036021	ロッカクアナツキホルト M5X135	Bolt M5X135	1
F 121		ME10A0390	Yクドウシク	Driving shaft Y	1
F 122		M95048021	ロッカクアナツキホルト M5X50	Bolt M5X50	2
F 123		M90504053	ハネサガネ 5	Spring washer 5	2
F 124	B	M95001017	セフティソケット M5X20	Bolt M5X20	4
F 125		ME10A0850	Yモータダイ	Motor bracket Y	1
F 126		ME10A0758	ブラケット Y	Bracket Y	1
F 127		ME10A0523	タイミングベルト Y	Cog belt Y 15T5-375(75Z)	1
F 128		M91003070	ボールブッシュ 10	Ball bushing 10	2
F 129		ME10A2390	Yクドウシク	Linear shaft Y	1
F 130		M90448037	Pサラネジ M4X12	Screw M4X12	2
F 131		ME10A0778	Yベルトオサエ	Belt clamber Y	1
F 132		MS14A0781	Yベルトダイ	Belt holder Y	1

**G** X-Yテーブル機構(2)  
X-Y TABLE MECHANISM(2)

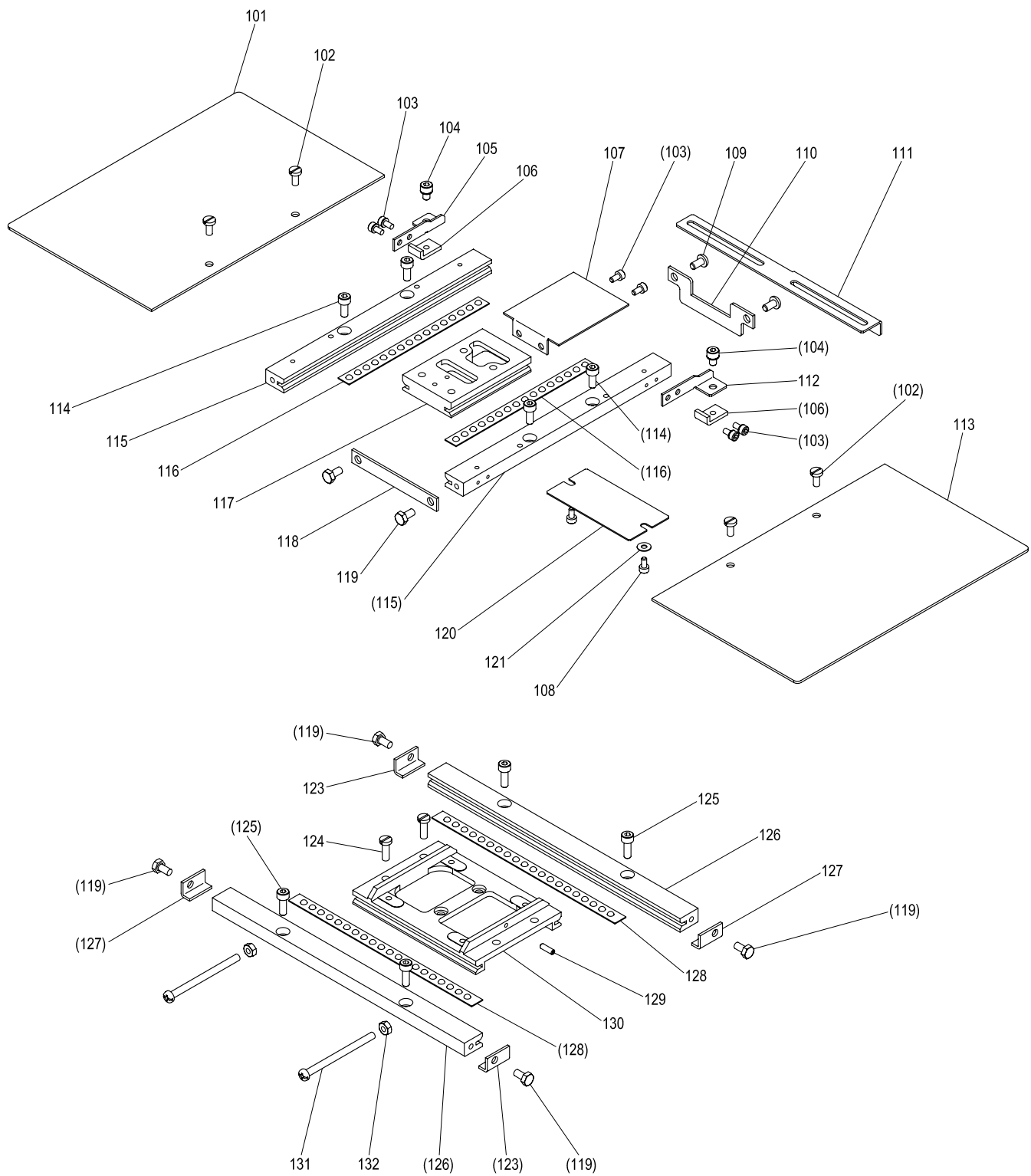

[G]X-Yテーブル機構(2)  
X-Y TABLE MECHANISM (2)

Fig no.	変更 Mod.	部品コード Parts no.	品名	Description	数量 Amt. Req.
G 101		ME10A2339	カバー L	Cover L	1
G 102		M90921002	ヒラネジ 9/64(40)X8	Screw 9/64(40)X8	4
G 103		M94003017	セフティソケット M3X6	Bolt M3X6	6
G 104		M94008017	セフティソケット M4X6	Bolt M4X6	2
G 105		ME10A1426	ケンシュツハンササエ (L)	Detector holder L	1
G 106		MB60A2601	ネジイタ	Holder plate	2
G 107		ME10A4339	Yカバーイタ	Cover plate Y	1
G 108		M93003021	ロッククアナツキボルト M3X6	Bolt M3X6	2
G 109		M94035021	ロッククアナツキボルト M4X8	Bolt M4X8	2
G 110		ME10A0477	ストップ Y ウシロ	Rear stopper Y	1
G 111		MB60A0407	ケンシュツハン X	Detector plate X	1
G 112		ME10A0426	ケンシュツハンササエ (R)	Detector holder R	1
G 113		ME10A3339	カバー R	Cover R	1
G 114		M91060021	ロッククアナツキボルト M4X10	Bolt M4X10	4
G 115		ME10A0957	Yシクコテイレース	Fixed race Y	2
G 116		ME10A0972	ローラーケージ Y	Roller cage Y	2
G 117		MS14A4957	Yシクタイトウレース	Movable race Y	1
G 118		MA04A0477	ストップ Y マエ	Front stopper Y	1
G 119		M91003022	ロッククボルト M4X8	Bolt M4X8	6
G 120		ME10A5339	カバー	Cover	1
G 121		M90316050	ザガネ 3	Washer 3	2
G 123		MS02A3477	ストップ X	Stopper X	2
G 124		M90991002	ヒラネジ M4X12	Screw M4X12	2
G 125		M94003021	ロッククアナツキボルト M4X12	Bolt M4X12	4
G 126		MB60A0957	Xシクコテイレース	Fixed race X	2
G 127		MS02A4477	ストップ X	Stopper X	2
G 128		MS14A0972	ローラーケージ X	Roller cage X	2
G 129	C	M93009020	ロッククアナツキトメネジ M3X8	Screw M3X8	1
G 130		MB60A1957	Xシクタイトウレース	Movable race X	1
G 131		M91083004	プラマイナヘネジ M4X55	Screw M4X55	2
G 132		M91004045	ナット M4	Nut M4	2

H 外押え機構(1)  
WORK HOLDER MECHANISM(1)

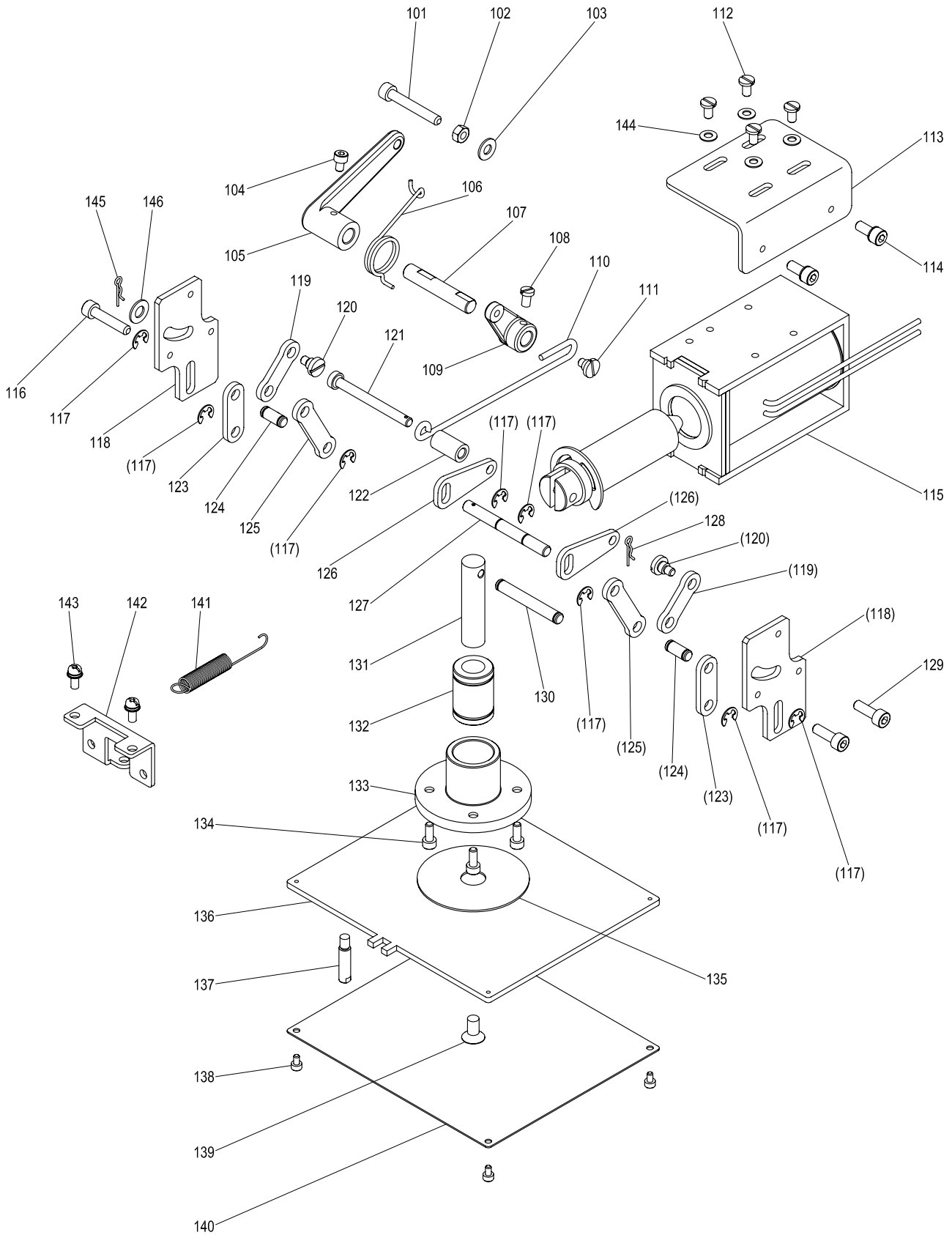



## [H]外押え機構(1)

## WORK HOLDER MECHANISM (1)

Fig no.	変更 Mod.	部品コード Parts no.	品名	Description	数量 Amt. Req.
H 101		M95008021	ロックアナツキボルト M5X35	Bolt M5X35	1
H 102		M91382045	ナット M5	Nut M5	1
H 103		M90511050	ワッシャ 5	Washer 5	1
H 104		M94001021	ロックアナツキボルト M4X6	Bolt M4X6	1
H 105		MA10A0950	レバー	Lever	1
H 106		MA10A0729	ヒネリバネ	Spring	1
H 107		MA10A0454	シャフト	Shaft	1
H 108		M91109002	ヒラネジ 11/64(40)X7	Screw 11/64(40)X7	1
H 109		MA10A1950	レバー	Lever	1
H 110		ME10A1910	リンク	Link	1
H 111		M91137015	ヒラネジダンツキ 11/64(40)	Screw 11/64(40)	1
H 112		M91116002	ヒラネジ 11/64(40)X8	Screw 11/64(40)X8	4
H 113		ME10A1758	ブラケット	Bracket	1
H 114	B	M95002017	セフティソケット M5X12	Bolt M5X12	2
H 115		ME10E0519	ソレノイドクミタテ	Solenoid assy	1
H 116		M95011021	ロックアナツキボルト M5X25	Bolt M5X25	2
H 117		M90505065	Eタイプメワ 5	E-type retaining ring 5	8
H 118		ME10A0743	ガイドプレート	Guide plate	2
H 119		ME10A3910	リンク A	Link A	2
H 120		M91127015	ヒラネジダンツキ 11/64(40)	Screw 11/64(40)	2
H 121		M90543060	ピン	Pin	1
H 122		ME10A0352	カラー	Collar	1
H 123		ME10A2910	リンク B	Link B	2
H 124		M90619060	ピン C	Pin C	2
H 125		ME10A4910	リンク C	Link C	2
H 126		ME10A5910	リンク S	Link S	2
H 127		M90618060	ピン A	Pin A	1
H 128		M90518060	スナップピン R5	Snap pin R5	1
H 129		M95001021	ロックアナツキボルト M5X16	Bolt M5X16	2
H 130		M90620060	ピン E	Pin E	1
H 131		ME10A0454	オサエシク	Shaft	1
H 132	C	M94010070	ボールブッシュ 12	Ball bushing 12	1
H 133		ME10A0267	オサエイタメタル	Bushing	1
H 134	B	M95018021	ロックアナツキボルト M4X8	Bolt M4X8	4
H 135		MS14A0416	カンショウイタ	Cushion	1
H 136		ME10A0257	オサエイタ	Pressure plate	1
H 137		ME10A0802	マワリドメ	Guide pin	1
H 138		M93004021	ロックアナツキボルト M3X5	Bolt M3X5	4
H 139		M96033021	ロックアナツキサラボルト M6X12	Bolt M6X12	1
H 140		ME10A8339	スライドカバー	Slide cover	1
H 141	B	ME10A1572	ツルマキバネ	Spring	1
H 142		MB60A0780	ホルダー	Holder	1
H 143	B	M91054004	SW-PWフライマインベネジ M4X8	Screw M4X8	2
H 144	B	M90110053	サラハネサガネ 1L-4	Spring washer 1L-4	4
H 145	B	M90105062	スナップピン R5	Snap pin R5	1
H 146	B	M90631050	ワッシャ 6	Washer 6	1

**J** 外押え機構(2)  
**WORK HOLDER MECHANISM(2)**

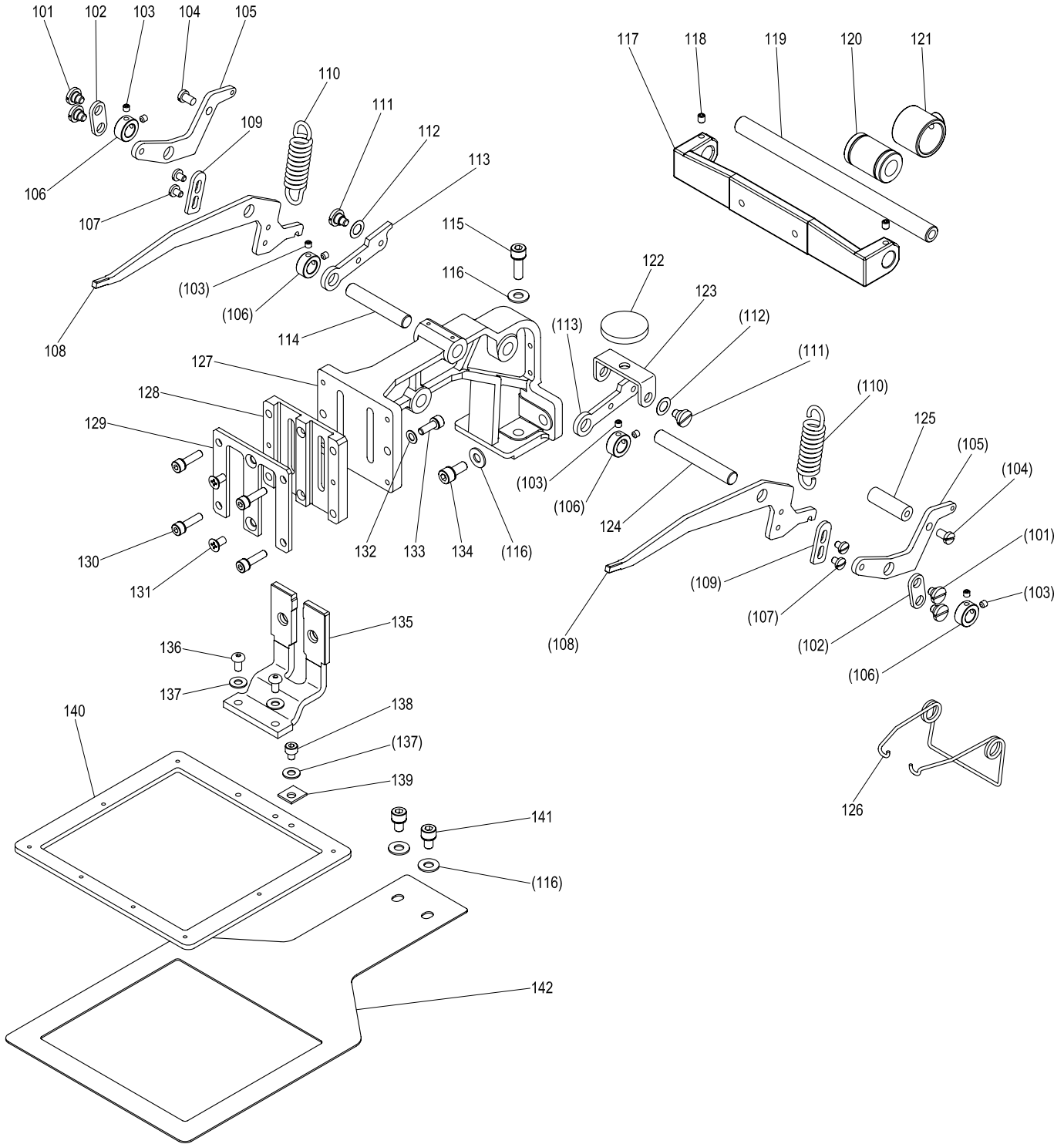

## [J]外押え機構(2)

## WORK HOLDER MECHANISM (2)

Fig no.	変更 Mod.	部品コード Parts no.	品名	Description	数量 Amt. Req.
J 101		M91139015	ヒラネジ <sup>タ</sup> ツキ 11/64(40)	Screw 11/64(40)	4
J 102		ME10A0910	リンク	Link	2
J 103		M90901020	ロッククアナツキメネジ <sup>シ</sup> 9/64(40)X3.5	Screw 9/64(40)X3.5	8
J 104		M91109002	ヒラネジ <sup>シ</sup> 11/64(40)X7	Screw 11/64(40)X7	2
J 105		ME10A0429	ササエイタ	Pressure lever B	2
J 106		MF00A1352	カラー	Collar	4
J 107		M90983002	マルヒラネジ <sup>シ</sup> 9/64(40)X5	Screw 9/64(40)X5	4
J 108		ME10A0266	オサエレバ <sup>ー</sup>	Pressure lever A	2
J 109		MB60A0477	ストッパ <sup>ハ</sup>	Stopper	2
J 110		ME10A0700	ツルマキハ <sup>ネ</sup>	Spring	2
J 111		M91137015	ヒラネジ <sup>タ</sup> ツキ 11/64(40)	Screw 11/64(40)	2
J 112		M99002052	ウェーブワッシャ 1417003-41006	Wave washer 1417003-41006	2
J 113		ME10A1266	オサエレバ <sup>ー</sup>	Pressure lever C	2
J 114		M90817060	ピン L=46	Pin L=46	1
J 115		M95004017	セフティソケット M5X16	Bolt M5X16	2
J 116		M90511050	サ <sup>ガ</sup> ネ 5	Washer 5	6
J 117		MA10A0455	ジ <sup>ク</sup> ササエ	Bracket	1
J 118		M91050020	ロッククアナツキメネジ <sup>シ</sup> M4X5	Screw M4X5	2
J 119		MS14A4454	ジ <sup>ク</sup>	Shaft	1
J 120		M91003070	ホ <sup>ール</sup> ブ <sup>ッ</sup> シュ 10	Ball bushing 10	1
J 121		MS08A0692	ジ <sup>ク</sup> ウケハウシ <sup>ン</sup> グ	Bearing housing	1
J 122		ME10A0457	シュウ <sup>ト</sup> ウシ	Slider	1
J 123		ME10A1601	トリツケイ <sup>タ</sup>	Bracket	1
J 124		M90818060	ピン L=60	Pin L=60	1
J 125		ME10A1454	レンケツジ <sup>ク</sup>	Connecting shaft	1
J 126		ME10A0729	ヒネリハ <sup>ネ</sup>	Spring	1
J 127		ME10A0308	オサエ <sup>タ</sup> イ	Work holder arm	1
J 128		ME10A0307	オサエアン <sup>ナ</sup> イ	Work holder guide	1
J 129		ME10A6339	カ <sup>ハ</sup>	Cover	1
J 130		M94006017	セフティソケット M4X16	Bolt M4X16	4
J 131		M91400010	Pサラネジ <sup>シ</sup> M4X8	Screw M4X8	2
J 132		M90422050	サ <sup>ガ</sup> ネ 4	Washer 4	2
J 133		M94007017	セフティソケット M4X12	Bolt M4X12	2
J 134		M95002017	セフティソケット M5X12	Bolt M5X12	2
J 135		ME10A0601	オサエトリツケイ <sup>タ</sup>	Clamp foot	1
J 136		M94035021	ロッククアナツキホ <sup>ト</sup> ン <sup>ホ</sup> ルト M4X8	Bolt M4X8	2
J 137		M90421050	サ <sup>ガ</sup> ネ 4	Washer 4	3
J 138		M94009021	ロッククアナツキホ <sup>ト</sup> M4X5	Bolt M4X5	1
J 139		MB60A0196	イチキ <sup>メ</sup> イ <sup>タ</sup>	Clamp stopper	1
J 140		ME10A0105	オサエ	Clamp frame	1
J 141	B	M95005017	セフティソケット M5X10	Bolt M5X10	2
J 142		ME10A0272	オクリイ <sup>タ</sup>	Feed plate	1

**K** 糸切り機構  
 THREAD TRIMMING MECHANISM

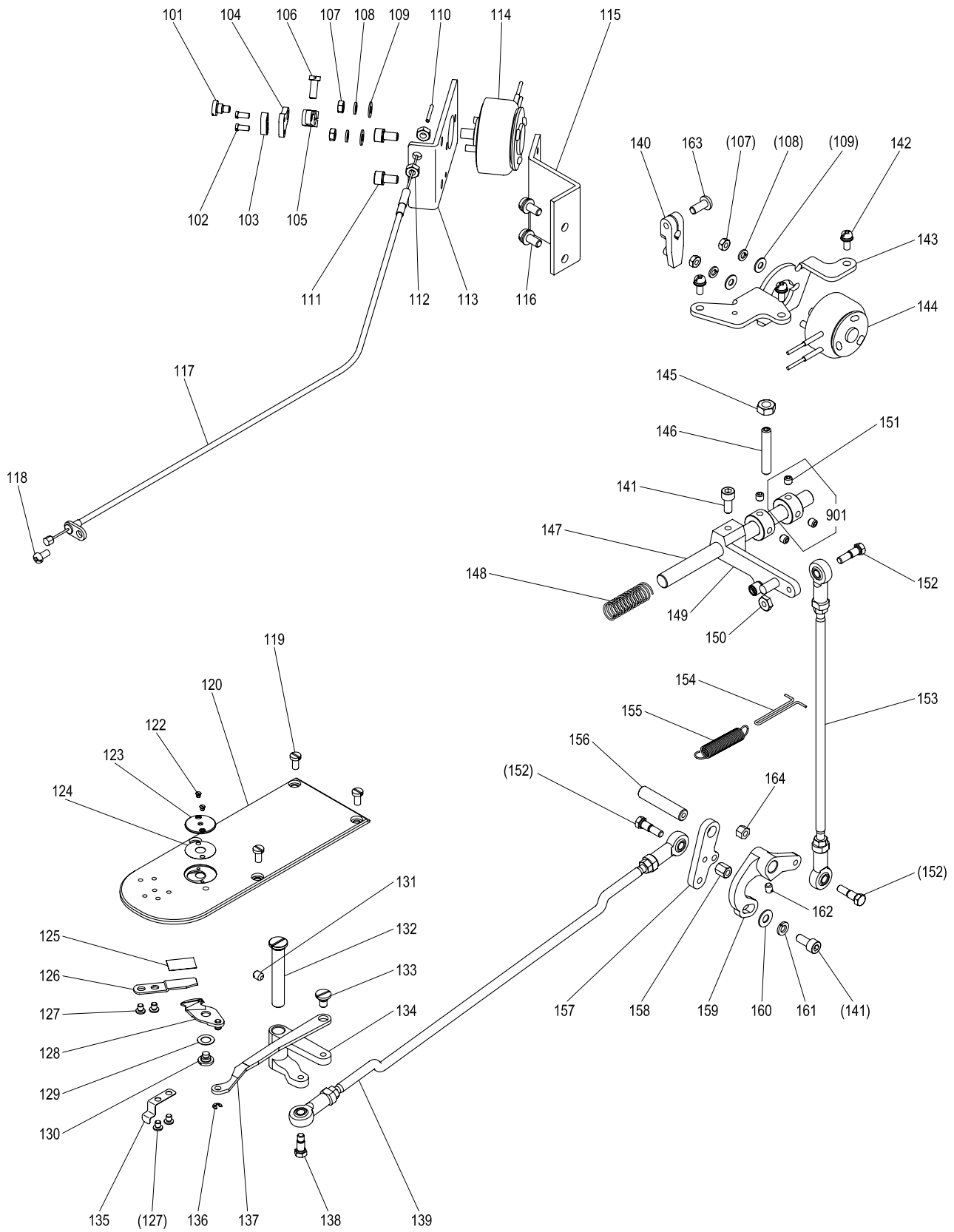

[K]系切り機構

THREAD TRIMMING MECHANISM

Fig no.	変更 Mod.	部品コード Parts no.	品名	Description	数量 Amt. Req.
K 101		M91127015	ヒラネジ <sup>ダ</sup> ンツキ 11/64(40)	Screw 11/64(40)	1
K 102		M90802002	ヒラネジ <sup>ダ</sup> 1/8(44)X7	Screw 1/8(44)X7	2
K 103		MF36A0750	ホルダ	Holder	1
K 104		MF90A0361	カケガネ	Bracket	1
K 105		MS07A0228	ウテ	Crank	1
K 106		M91112002	ヒラネジ <sup>ダ</sup> 11/64(40)X12	Screw 11/64(40)X12	1
K 107		M91004045	ナット M4	Nut M4	4
K 108		M90424053	ハネサガネ 4	Spring washer 4	4
K 109		M90421050	ザガネ 4	Washer 4	4
K 110		MN60A0750	プッシュ	Pipe	1
K 111		M95005017	セフティソケット M5X10	Bolt M5X10	2
K 112		M91382045	ナット M5	Nut M5	2
K 113		MA20A0603	ソレノイドトリツケイタ	Solenoid bracket	1
K 114		ME10E3519	イトユルメソレノイド	Solenoid (thread release)	1
K 115		MA10A0601	トリツケイタ	Bracket	1
K 116		M91331004	SW-PW <sup>ラ</sup> マイナ <sup>ハ</sup> ネジ M5X12	Screw M5X12	2
K 117		ME10E0746	フレキシブルワイヤ	Flexible wire assy	1
K 118	B	M91069004	<sup>ラ</sup> マイナ <sup>ハ</sup> ネジ M4X8	Screw M4X8	1
K 119		M90990002	ヒラネジ <sup>ダ</sup> M4X8	Screw M4X8	4
K 120	B	MS14A0472	スベリイタ (ナカ)	Slide plate (center)	1
K 122		M90605010	サラネジ <sup>ダ</sup> 3/32(56)X2.8	Screw 3/32(56)X2.8	2
K 123		MS03A1101	ハリイタ φ2.2	Needle plate	1
K 124		MS01A1476	スペーサ	Spacer	1
K 125		MA10B2476	スペーサ	Spacer	1
K 126		MS14A0838	コテイメス	Fixed knife	1
K 127		M90906003	マルヒラネジ <sup>ダ</sup> 9/64(40)X3.2	Screw 9/64(40)X3.2	4
K 128		MS03B0838	イトウメス	Movable knife	1
K 129		M96004052	ウェーブワッシャ 6	Wave washer 6	1
K 130		M91129015	ヒラネジ <sup>ダ</sup> ンツキ 11/64(40)	Screw 11/64(40)	1
K 131	B	M91224001	トメネジ <sup>ダ</sup> M5X8	Screw M5X8	1
K 132		MS01A5454	ツバ <sup>ツ</sup> ツジク	Stepped pin	1
K 133		M91214015	ヒラネジ <sup>ダ</sup> ンツキ 3/16(28)	Screw 3/16(28)	1
K 134		MA20A0392	メスクト <sup>ウ</sup> ウテ (3)	knife driving crank (3)	1
K 135		MS01A0192	イタハネ	Leaf spring	1
K 136		M90513065	E <sup>カ</sup> 外 <sup>メ</sup> ワ 2.5	E-type retaining ring 2.5	1
K 137		MS03A1910	リンク	Link	1
K 138		M90102017	ホルト <sup>ダ</sup> ンツキ 11/64(40)	Bolt 11/64(40)	1
K 139		ME10E0975	ロツ <sup>ト</sup> エ <sup>ント</sup> クミ <sup>タ</sup> テ (ヨコ)	Connecting rod (horizontal)	1
K 140		MS01E0430	イトキリサ <sup>ト</sup> ウ <sup>テ</sup>	Crank	1
K 141		M95003021	ロツ <sup>カ</sup> ア <sup>ナ</sup> ツ <sup>キ</sup> ホ <sup>ルト</sup> M5X12	Bolt M5X12	2
K 142		M91056004	SW-PW <sup>ラ</sup> マイナ <sup>ハ</sup> ネジ M4X10	Screw M4X10	3
K 143		MS14A3601	ソレノイドトリツケイタ	Solenoid bracket	1
K 144		ME10E2519	イトキリソレノイド	Solenoid (thread trim)	1
K 145		M91576045	ナット M6	Nut M6	1
K 146		M91652020	コネジ <sup>ダ</sup> M6X35	Screw M6X35	1
K 147		MS01A0348	カムシク	Shaft	1
K 148		MS01A1572	ツルマキハネ	Spring	1
K 149		MS01E0351	カムツイジ <sup>ユ</sup> ウ <sup>テ</sup> クミ	Cam follower assy	1
K 150		M91104045	ナット 11/64(40)	Nut 11/64(40)	1
K 151		M95004021	ロツ <sup>カ</sup> ア <sup>ナ</sup> ツ <sup>キ</sup> トメ <sup>ネジ</sup> M5X5	Screw M5X5	4
K 152		M90101017	ホルト <sup>ダ</sup> ンツキ 11/64(40)	Bolt 11/64(40)	3
K 153		MS01E0975	ロツ <sup>ト</sup> エ <sup>ント</sup> クミ <sup>タ</sup> テ (タテ)	Connecting rod (vertical)	1
K 154		MS08A0708	ハネカケ	Hook	1
K 155		MS01A2572	ツルマキハネ	Spring	1
K 156		MS08A0454	シク	Shaft	1
K 157		MS01A2392	メスクト <sup>ウ</sup> ウテ (2)	knife driving crank (2)	1
K 158		M91109045	ロングナット 11/64(40)	Long nut 11/64(40)	1
K 159		MS01A1392	メスクト <sup>ウ</sup> ウテ (1)	knife driving crank (1)	1
K 160		M90511050	ザガネ 5	Washer 5	1
K 161		M90504053	ハネサガネ 5	Spring washer 5	1
K 162		M91108001	トメネジ <sup>ダ</sup> 11/64(40)X5.5	Screw 11/64(40)X5.5	1
K 163	B	M95049021	ロツ <sup>カ</sup> ア <sup>ナ</sup> ツ <sup>キ</sup> ホ <sup>ルト</sup> M5X12	Molt M5X12	1
K 164	B	M91102045	ナット 11/64(40)	Nut 11/64(40)	1
K 901		MS01A3352	カラー <sup>ク</sup> ミ	Collar assy	2

**L** 中押え機構  
**PRESSER BAR LIFTING MECHANISM**

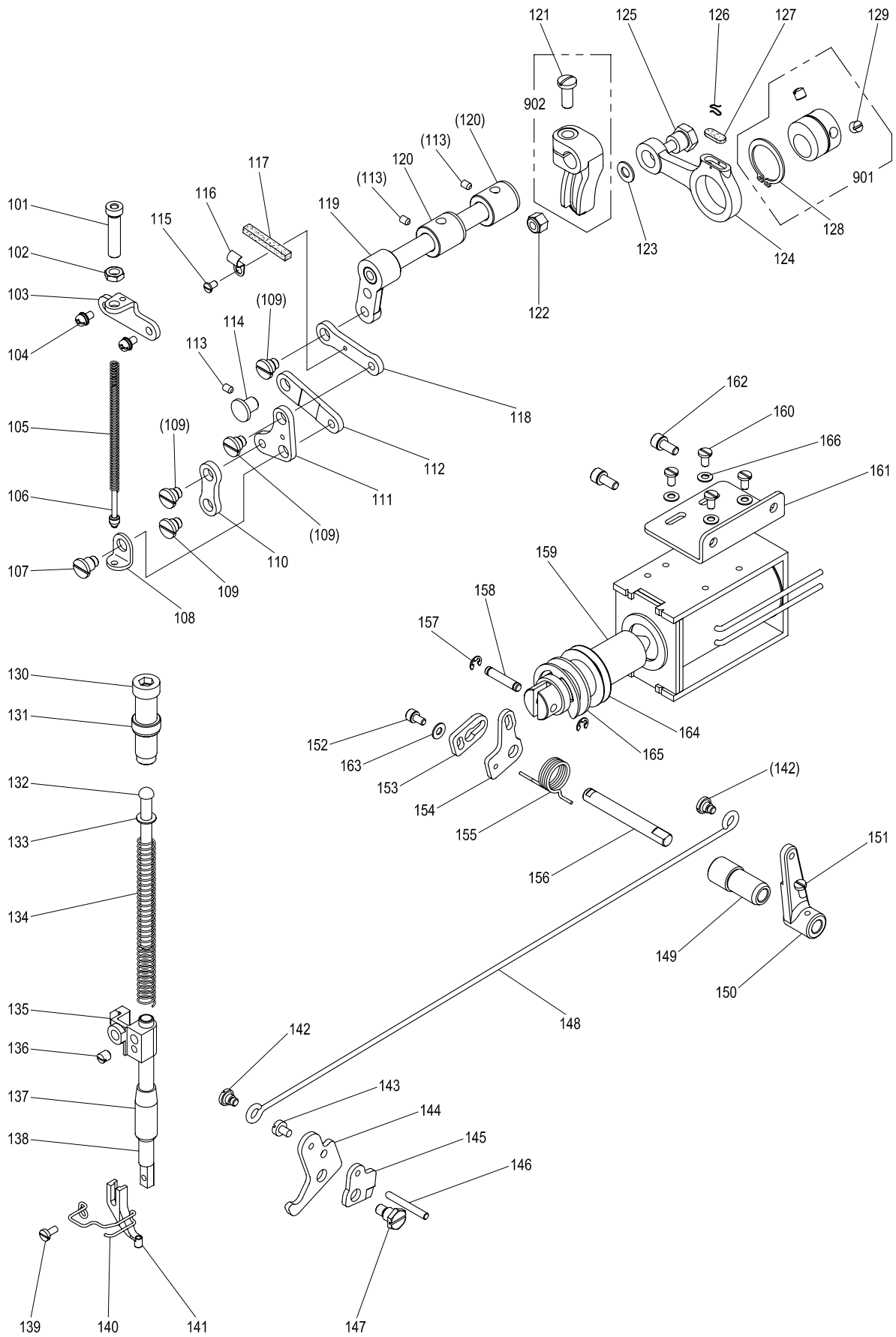

## [L] 中押え機構

## PRESSER BAR LIFTING MECHANISM

Fig no.	変更 Mod.	部品コード Parts no.	品名	Description	数量 Amt. Req.
L 101		M91801035	ツマミネジ 9/32(28)X35	Thumb screw 9/32(28)X35	1
L 102		M91802045	ナット 9/32(28)	Nut 9/32(28)	1
L 103		ME10A0261	オサエジョウセツダイ	Bracket	1
L 104	B	M91056004	SW-PWフライナハネネジ M4X10	Screw M4X10	2
L 105		ME10A0572	ツルマキハネ	Spring	1
L 106		MS03A6154	アンナイガネ	Spring guide bar	1
L 107		M91689015	ヒラネジダツキ 1/4(40)	Screw 1/4(40)	1
L 108		MG30B0226	オサエイタササエ	Supporter	1
L 109		M91688015	ヒラネジダツキ 1/4(40)	Screw 1/4(40)	4
L 110		ME10A6910	リンク	Link	1
L 111		ME10A0763	ベルクランク	Bell crank	1
L 112		ME10A7910	リンク	Link	1
L 113	B	M91058020	ロックアナツキトメネジ M4X10	Screw M4X10	3
L 114		M99006063	ツハツキシク	Pin	1
L 115		M90908003	マルヒラネジ 9/64(40)X6	Screw 9/64(40)X6	1
L 116		MN70A1780	ホルダ	Holder	1
L 117		MG30A0740	フェルト	Felt	1
L 118		ME10A1956	レンセツカン	Link	1
L 119		MS02E0460	ウデクミタテ	Arm shaft assy	1
L 120		MG30A0833	メタル	Bushing	2
L 121		M91603003	マルヒラネジ 1/4(40)X16	Screw 1/4(40)X16	1
L 122		M91572045	U ナット 6X0.75	U-nut 6X0.75	1
L 123		M90631050	サガネ 6	Washer 6	1
L 124		ME10A0956	レンセツカン	Crank rod	1
L 125		M91551015	ホルトダツキ M6	Bolt M6	1
L 126		MF60A0700	センサイウハネ	Holder	1
L 127		MG30B0740	フェルト	Felt	1
L 128		M90325065	Cガタメワ 25	C-type retaining ring 25	1
L 129		M91606001	トメネジ 1/4(40)X6	Screw 1/4(40)X6	2
L 130		M93202045	ツマミネジ 1/2(28)X43	Thumb screw 1/2(28)X43	1
L 131		M93202047	ナット 1/2(28)	Nut 1/2(28)	1
L 132		MS03A0703	アンナイボウ	Presser bar guide	1
L 133		M90632050	コサガネ 6	Washer 6	1
L 134		MS03A1572	ツルマキハネ	Spring	1
L 135		MG75A0265	オサエボウダキ	Presser bar holder	1
L 136		M91506001	トメネジ 15/64(28)X6	Screw 15/64(28)X6	1
L 137		MF10A0267	オサエボウメタル	Bushing	1
L 138		MS03A0262	オサエボウ	Presser bar	1
L 139		M90922002	ヒラネジ 9/64(40)X8	Screw 9/64(40)X8	1
L 140		MB60A1626	ニートルガード	Needle guard	1
L 141		MV30A0256	オサエ φ3	Presser foot φ3	1
L 142		M91219015	ヒラネジダツキ 3/16(28)	Screw 3/16(28)	2
L 143		M91131002	ヒラネジ 11/64(40)X6.5	Screw 11/64(40)X6.5	1
L 144		ME10A1252	オサエアケレバ	Lifting lever	1
L 145		MF70A0350	イトルメカム	Plate cam	1
L 146		M90423060	イトルメピン	Pin	1
L 147		M91515022	ホルトダツキ 15/64(28)	Bolt 15/64(28)	1
L 148		ME10A0738	ヒキボウ	Link	1
L 149	C	ME10A1833	メタル	Bushing	1
L 150		ME10A0950	レバ	Lever	1
L 151		M90990002	ヒラネジ M4X8	Screw M4X8	1
L 152	B	M94002017	セフティソケット M4X8	Bolt M4X8	1
L 153	B	ME10A1810	マワリドメイタ	Holder	1
L 154	B	ME10A2252	オサエアケレバ	Lifting lever	1
L 155	C	ME10A2729	ヒネリハネ	Spring	1
L 156		ME10A2454	ジク	Shaft	1
L 157	C	M90504065	Eガタメワ 4	E-type retaining ring 4	2
L 158		M90432060	ピン	Pin	1
L 159		ME10E1519	ソレノイドクミタテ	Solenoid assy	1
L 160		M91116002	ヒラネジ 11/64(40)X8	Screw 11/64(40)X8	4
L 161		ME10A2601	ソレノイドトリツケイタ	Bracket	1
L 162		M95002017	セフティソケット M5X12	Bolt M5X12	2
L 163	B	M90421050	サガネ 4	Washer 4	1
L 164	B	M92004050	ショウオンワッシャ	Washer	2
L 165	B	M92003050	ショウオンワッシャ	Washer	1
L 166	B	M90110053	サラハネサガネ 1L-4	Spring washer 1L-4	4
L 901		MG30A0760	ヘンシンリンクミタテ	Eccentric cam assy	1
L 902		MS02A0463	ウデ(ミキ)	Arm (right)	1

M ワイパー機構  
WIPER MECHANISM

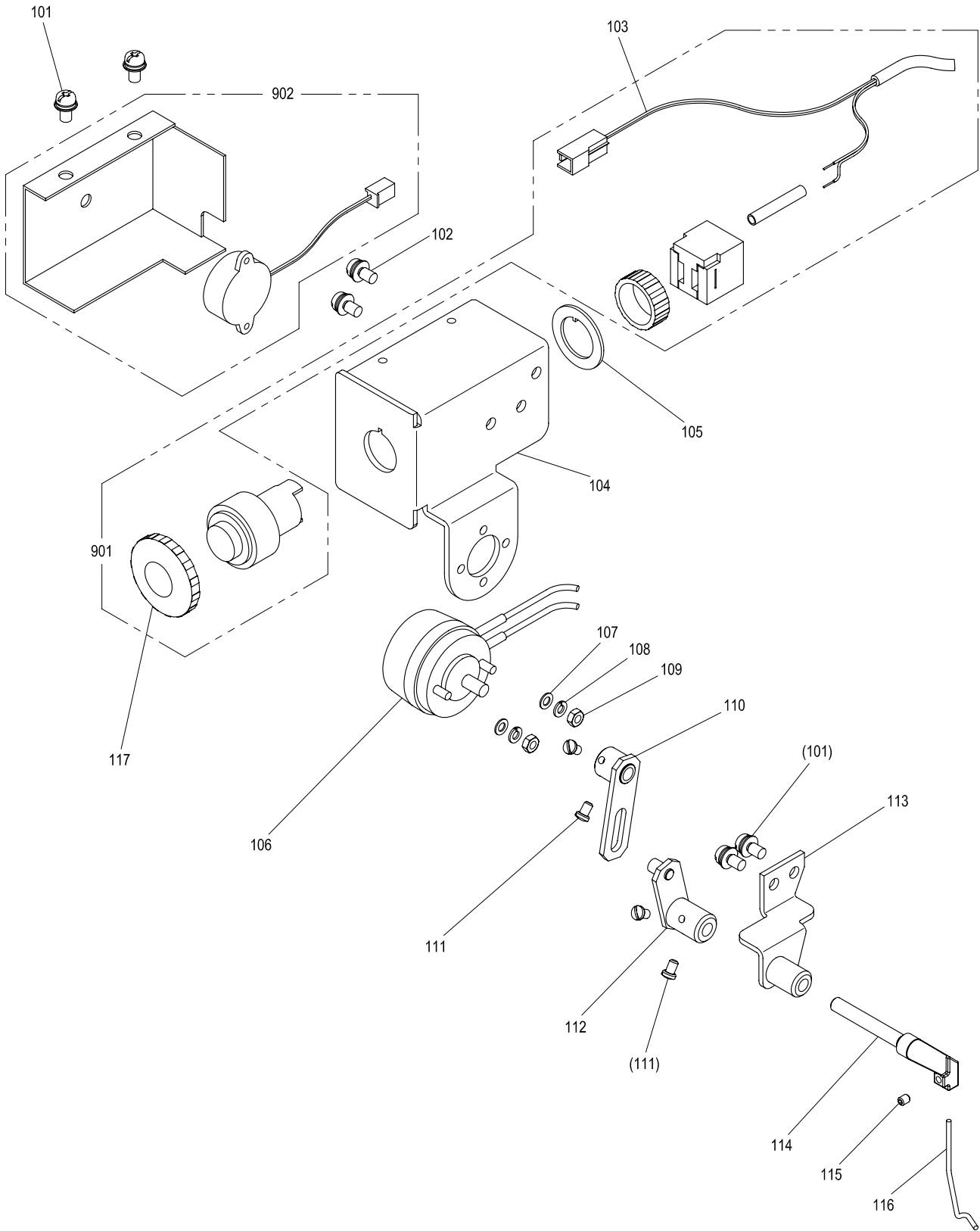



[M]ワイパー機構  
WIPER MECHANISM

Fig no.	変更 Mod.	部品コード Parts no.	品名	Description	数量 Amt. Req.
M 101	B	M91054004	SW-PW <sup>ラ</sup> マイナ <sup>ベ</sup> ネジ <sup>シ</sup> M4X8	Screw M4X8	4
M 102	B	M91056004	SW-PW <sup>ラ</sup> マイナ <sup>ベ</sup> ネジ <sup>シ</sup> M4X10	Screw M4X10	2
M 103		M97356099	セツク <sup>テ</sup> ンセン	Cable (stop BZ)	1
M 104		ME10E3601	トリツケ <sup>イ</sup> タ	Bracket	1
M 105		MB60A0915	ロック <sup>リ</sup> ング	Lock ring	1
M 106		ME10E4519	ワイパ <sup>ー</sup> ソレノ <sup>イ</sup> ド	Solenoid (wiper)	1
M 107		M90317050	サ <sup>カ</sup> ネ 3	Washer 3	2
M 108		M90307053	バ <sup>ネ</sup> サ <sup>カ</sup> ネ 3	Spring washer 3	2
M 109		M90875045	ナ <sup>ツ</sup> ト M3	Nut M3	2
M 110		MS02E0983	ク <sup>ト</sup> ウ <sup>イ</sup> タ	Wiper crank 1	1
M 111		M90802003	マルヒ <sup>ラ</sup> ネジ <sup>シ</sup> 1/8(44)X4.5	Screw 1/8(44)X4.5	4
M 112		MS03E0981	ジュ <sup>ウ</sup> ト <sup>ウ</sup> イ <sup>タ</sup>	Wiper crank 2	1
M 113		MB60E0982	ワイパ <sup>ー</sup> ダ <sup>イ</sup>	Wiper adapter	1
M 114		MS03A1530	ワイパ <sup>ー</sup> ジ <sup>ク</sup>	Wiper shaft	1
M 115		M91057020	ロック <sup>カ</sup> ア <sup>ナ</sup> ツ <sup>キ</sup> ト <sup>メ</sup> ネジ <sup>シ</sup> M3X4	Screw M3X4	1
M 116		MS03A3980	ワイパ <sup>ー</sup>	Wiper	1
M 117	B	ME03A0270	プ <sup>ッ</sup> シュ <sup>ホ</sup> タ <sup>ン</sup>	Push button	1
M 901		ME10E0270	オン <sup>ホ</sup> タ <sup>ン</sup> ス <sup>イ</sup> ツ <sup>チ</sup> ク <sup>ミ</sup>	Switch assy	1
M 902		MB60E3339	カ <sup>ハ</sup> ク <sup>ミ</sup> (フ <sup>サ</sup> ツ <sup>キ</sup> )	Cover assy (with buzzer)	1

**N** 給油機構  
OIL LUBRICATION MECHANISM

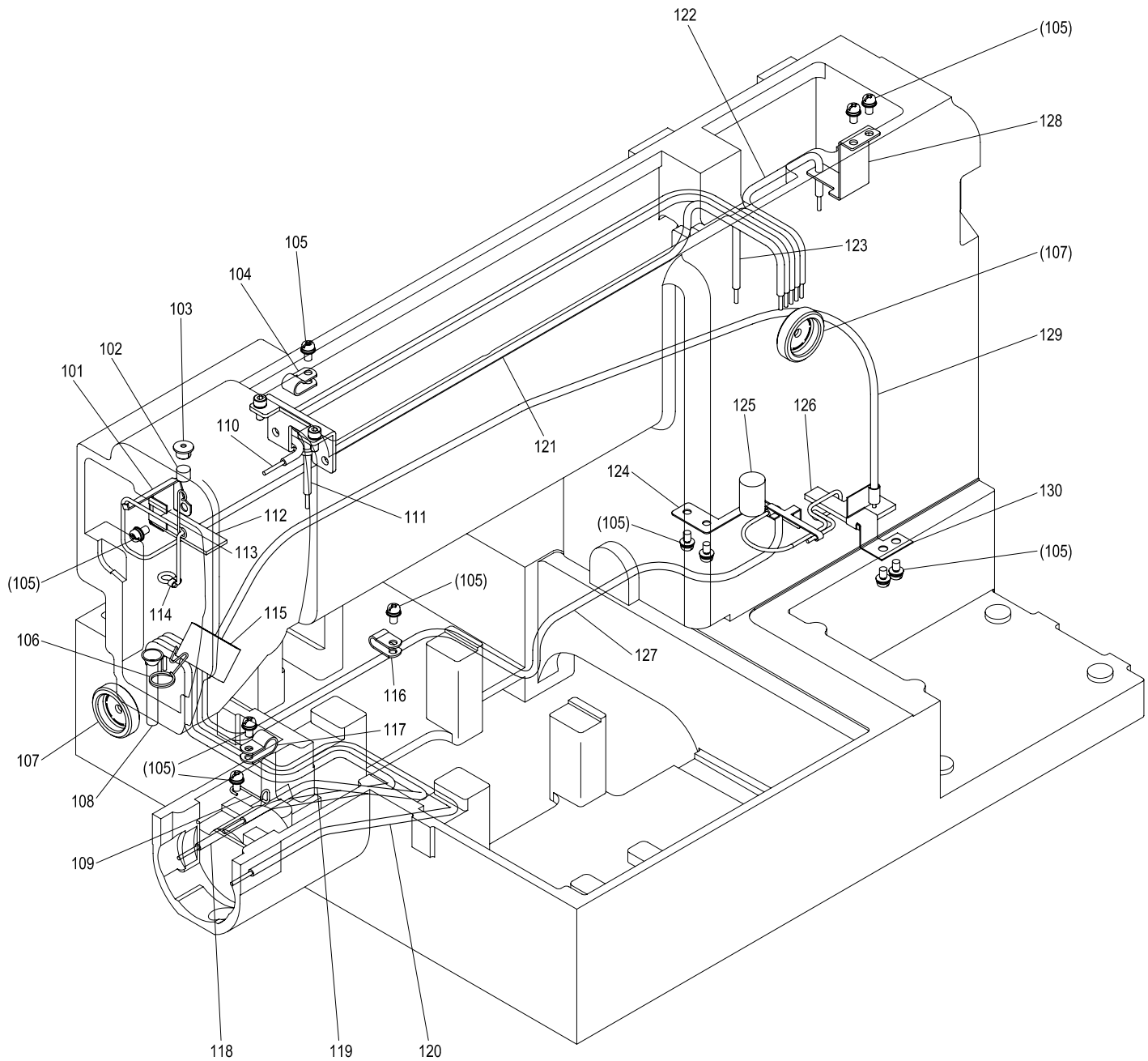

[N] 給油機構

OIL LUBRICATION MECHANISM

Fig no.	変更 Mod.	部品コード Parts no.	品名	Description	数量 Amt. Req.
N 101		ME10A1780	ホルダ	Holder	1
N 102		MF10A2740	フェルト	Felt	1
N 103		MF60A0742	フタ	Cap	1
N 104		M94004099	ナイロンクリップ AB-4N	Nylon clip AB-4N	1
N 105		M91054004	SW-PWフライナネジ M4X8	Screw M4X8	11
N 106		MF00A2780	ホルダ	Holder	1
N 107		MN10A0135	オイルゲージ	Oil gauge	2
N 108		MS10A0688	パイプ (アルミ)	Pipe	1
N 109		MS01A8796	ホルダ	Holder	1
N 110		ME10E1688	パイプヒモクミ (ウワジクメタル マエ)	Oil pipe assy (drive shaft bushing F)	1
N 111		ME10E2688	パイプヒモクミ (ヘンシンリン)	Oil pipe assy (eccentric cam)	1
N 112		MS01A1740	フェルト	Felt	1
N 113		MS03A2780	ホルダ	Holder	1
N 114		MF80A0780	ホルダ	Holder	1
N 115		MS01A0740	フェルト	Felt	1
N 116		M94003099	ナイロンクリップ AB-3N	Nylon clip AB-3N	1
N 117		MN60A0620	ナイロンクリップ AB-5N	Nylon clip AB-5N	1
N 118		ME10E3688	パイプヒモクミ (カマ ヒタリ)	Oil pipe assy (hook left)	1
N 119		ME10E4688	パイプヒモクミ (カマ ナカ)	Oil pipe assy (hook center)	1
N 120		ME10E5688	パイプヒモクミ (カマ ミキ)	Oil pipe assy (hook right)	1
N 121		ME10E6688	パイプヒモクミ (ハリホウ)	Oil pipe assy (needle bar)	1
N 122		ME10E7688	パイプヒモクミ (レンセツカン)	Oil pipe assy (connecting rod)	1
N 123		ME10E8688	パイプヒモクミ (ウワジクメタル ナカ)	Oil pipe assy (drive shaft bushing C)	1
N 124		MS14A3780	ホルダ	Holder	1
N 125		MF60A5740	フェルト	Felt	1
N 126		MS14A0740	フェルト	Felt	1
N 127		ME10E9688	パイプヒモクミ (シタジクメタル ウシロ)	Oil pipe assy (hook shaft bushing R)	1
N 128		MB60A1780	ホルダ	Holder	1
N 129		ME10F0688	パイプヒモクミ (カンユ)	Oil pipe assy (circulation)	1
N 130		MS01A9796	ホルダ	Holder	1

**P** 配線検出器関係  
CABLE COMPONENT & DETECTOR MECHANISM

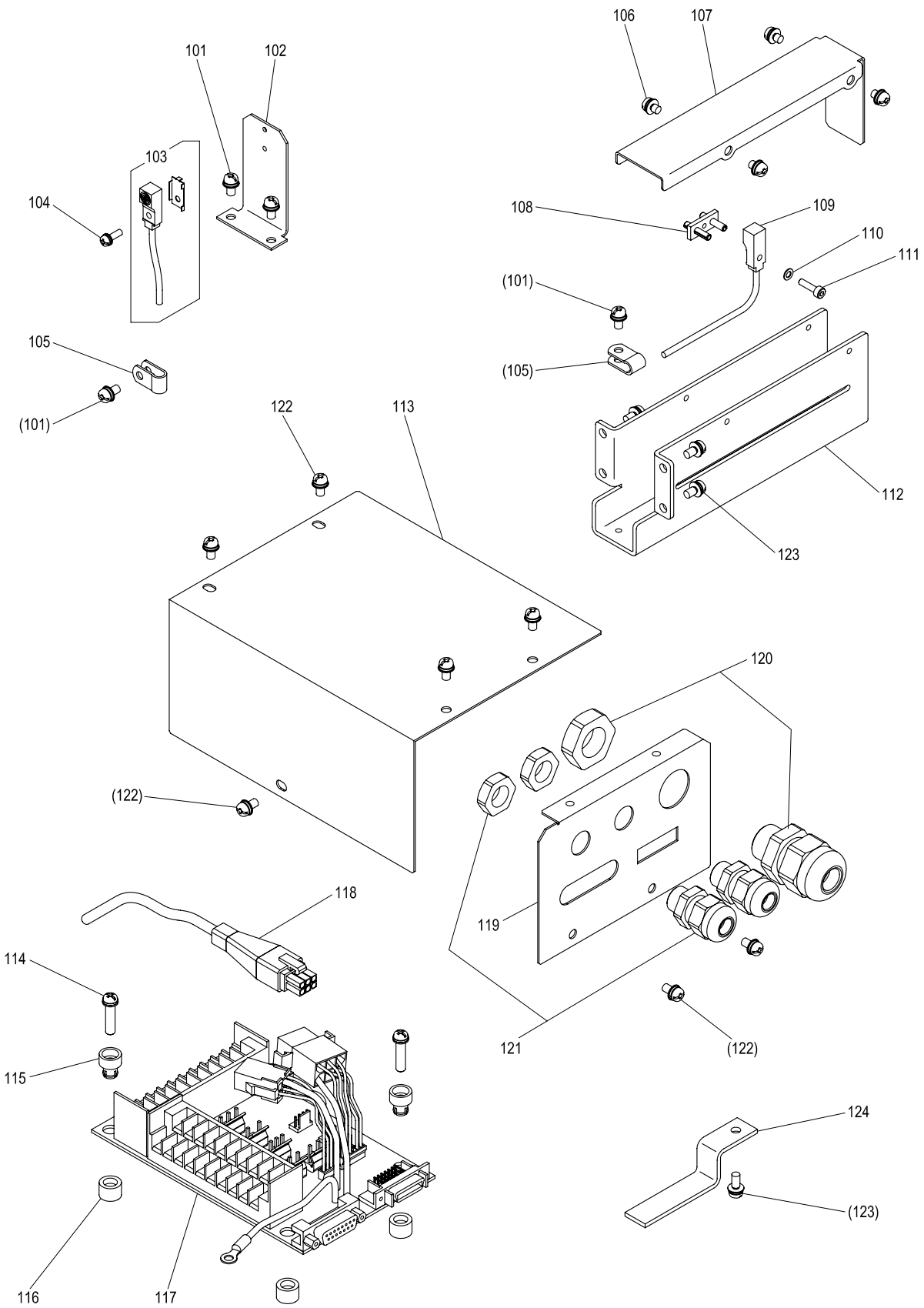

[P]配線・検出器関係

CABLE COMPONENT & DETECTOR MECHANISM

Fig no.	変更 Mod.	部品コード Parts no.	品名	Description	数量 Amt. Req.
P 101		M91054004	SW-PWﾌﾟﾗﾏｲﾅへﾞﾈｼﾞ M4X8	Screw M4X8	4
P 102		ME10A0408	ｹﾝｼﾞｬｯｼﾞﾀﾞｲ X	Detector bracket X	1
P 103		ME10E0484	ｷﾝｾｯｽｲｯﾁ X	Detector X	1
P 104		M90971004	SW-PWﾌﾟﾗﾏｲﾅへﾞﾈｼﾞ M3X10	Screw M3X10	1
P 105		M94003099	ﾅｲﾛﾝｸﾘｯﾌﾟ AB-3N	Nylon clip AB-3N	2
P 106		M91058004	SW-PWﾌﾟﾗﾏｲﾅへﾞﾈｼﾞ M4X6	Screw M4X6	4
P 107		ME10A9339	Yｹﾝｼﾞｬｯｼﾞｷｶﾊﾞｰ	Detector cover Y	1
P 108		ME10A2780	ﾈｼﾞｲﾀｸﾐﾀﾃ	Holder plate assy	1
P 109		ME10E1484	ｷﾝｾｯｽｲｯﾁ Y	Detector Y	1
P 110		M90317050	ｻﾞｶﾞﾈ 3	Washer 3	1
P 111		M93011021	ﾛｯｸｶﾞｱﾅｯｷﾎﾙﾄ M3X12	Bolt M3X12	1
P 112		ME10A1408	Yｹﾝｼﾞｬｯｼﾞﾀﾞｲ	Detector bracket Y	1
P 113		MB60A5339	Pﾊﾞﾝｶﾊﾞｰ	Circuit board cover	1
P 114		M91057004	SW-PWﾌﾟﾗﾏｲﾅへﾞﾈｼﾞ M4X20	Screw M4X20	4
P 115		MB60A0366	ワﾝﾀｯﾁﾌﾞｯｼﾞ	Nylon bush	4
P 116		MB60A2352	ワﾝﾀｯﾁﾌﾞｯｼﾞ	Nylon bush	4
P 117		M95003096	Pﾊﾞﾝｸﾐﾀﾃ	Print circuit board	1
P 118		K14M71725402	ｹｰﾌﾞﾙ (ｴﾝｺｰﾀﾞ)	Cable (Encoder)	1
P 119		MB60A5601	ｺﾈｸﾀﾄﾘｯﾁｹｲﾀ	Connector panel	1
P 120		MB60A5780	ｺｰﾄﾞﾌﾞｯｼﾞ ﾀﾞｲ	Cord bushing (large)	1
P 121		MB60A6780	ｺｰﾄﾞﾌﾞｯｼﾞ ショﾞ	Cord bushing (small)	2
P 122	B	M91071004	SW-MWﾌﾟﾗﾏｲﾅへﾞﾈｼﾞ M4X8	Screw M4X8	7
P 123	B	M91056004	SW-PWﾌﾟﾗﾏｲﾅへﾞﾈｼﾞ M4X10	Screw M4X10	5
P 124	B	ME10A0780	ﾎﾙﾀﾞ	Holder	1

Q テーブル関係  
TABLE & STAND

---

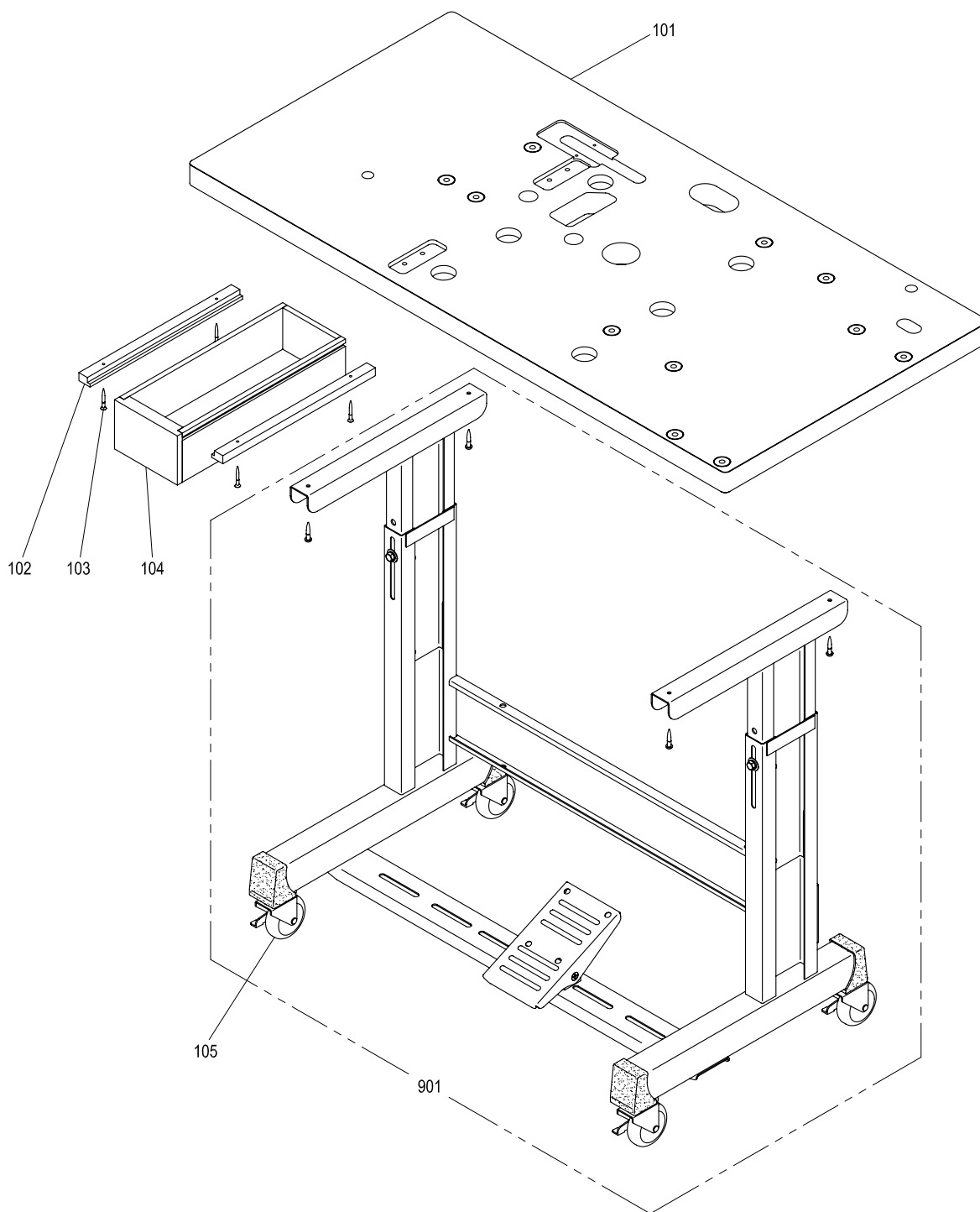

[Q]テーブル関係  
TABLE & STAND

Fig no.	変更 Mod.	部品コード Parts no.	品 名	Description	数量 Amt. Req.
Q 101		ME10A0595	テシイタ	Table top	1
Q 102		MB60A3957	レール	Rail	2
Q 103		M90406040	Pサラモクネシ φ 4.5X38	Wooden screw φ 4.5X38	4
Q 104		MB60A0719	ヒキタシ	Drawer	1
Q 105		MB60A1368	キャスト	Caster	4
Q 901		MB60E0150	キャククミタテ	Leg assy	1

**R** 付属品(1)  
ACCESSORIES(1)

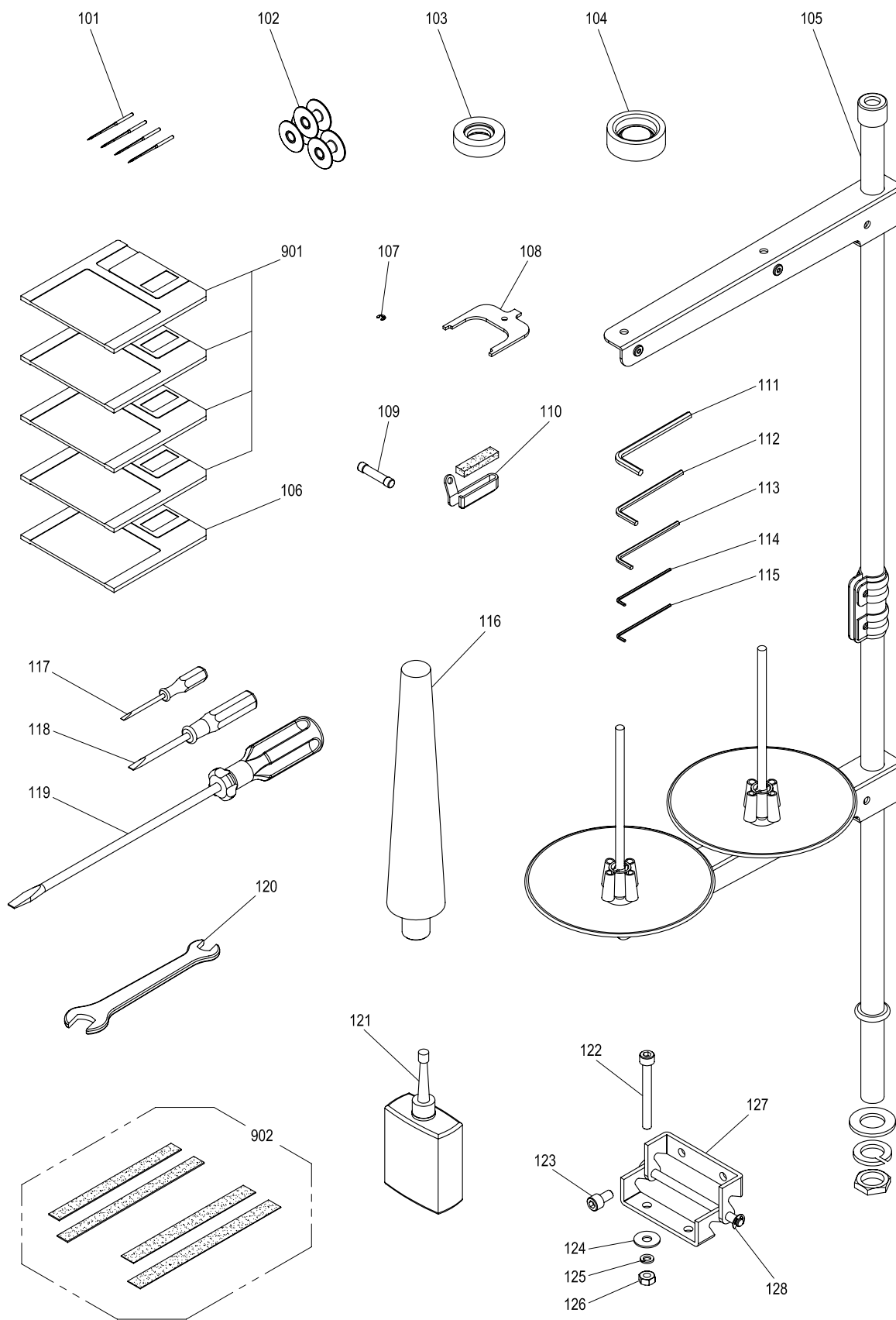



[R] 付属品(1)  
ACCESSORIES(1)

Fig no.	変更 Mod.	部品コード Parts no.	品 名	Description	数量 Amt. Req.
R 101		MS02A0128	ミシンハリ DPX17#18	Needle DPX17#18	4
R 102		MA10A0123	ホビン	Bobbin	3
R 103		MS03A0417	ゴムワ (イマキヨウ)	Tire (for bobbin winder)	1
R 104		MB60A0419	ホウシンゴム	Rubber cushion	6
R 105		MF40E0193	イトタテアイクミタテ	Cotton stand assy	1
R 106		MB60A1990	データフロッピイディスク	Pattern data F/D	1
R 107		M90513065	Eカク外メワ 2.5	E-type retaining ring 2.5	5
R 108		MF01A0565	カクチョウセイグ	Speed command disk adjusting plate	1
R 109		M82510FUS	ヒューズ	Fuse	2
R 110		MS03A0181	イトアンナイ	Thread guide	1
R 111		MS01A1976	ロツカクホウレンチ 4	Hexagonal wrench 4	1
R 112		MB18A1479	ロツカクホウレンチ 3	Hexagonal wrench 3	1
R 113		MB18A0479	ロツカクホウレンチ 2.5	Hexagonal wrench 2.5	1
R 114		MS10A0976	ロツカクホウレンチ 1.5	Hexagonal wrench 1.5	1
R 115		MN25A0479	ロツカクホウレンチ 1/16"	Hexagonal wrench 1/16"	1
R 116		MA10A1613	トウフササエ	Head rest	1
R 117		MB02A1608	ドライバ (ショウ)	Screw driver (small)	1
R 118		MB02A0608	ドライバ (チュウ)	Screw driver (middle)	1
R 119		MF00A0608	ドライバ (ダイ)	Screw driver (large)	1
R 120		MM10A1479	スパナ10-14	Spanner 10-14	1
R 121		MF10A0149	アブラサシ	Oiler with oil	1
R 122		M96020021	ロツカクアナツキボルト M6X55	Bolt M6X55	4
R 123		M96002017	セフテイソケット M6X12	Bolt M6X12	4
R 124		M90630050	ザガネ 6.5-18	Washer 6.5-18	4
R 125		M90624053	ハネサガネ 6	Spring washer 6	4
R 126		M91576045	ナット M6	Nut M6	4
R 127		MB60A0560	チョウバン	Hinge	2
R 128	B	M90809065	Eカク外メワ 5	E-type retaining ring 5	2
R 901		ME10A0990	システムフロッピイディスク (4マイ)	System F/D (4discs)	1
R 902		ME10E0691	ハッキンセット	Clamp pad set	1

S 付属品(2)  
ACCESSORIES(2)

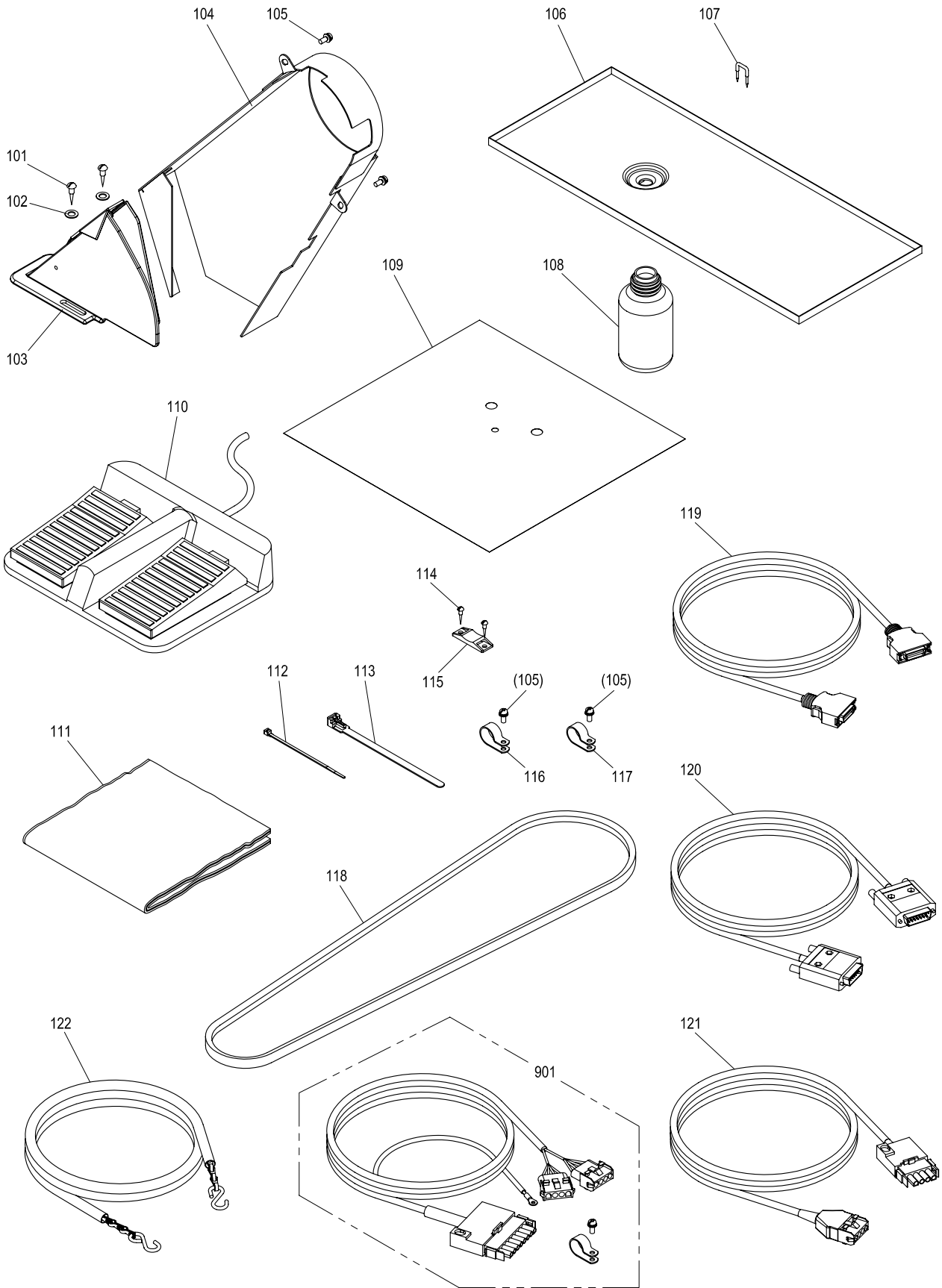

[S] 付属品(2)  
ACCESSORIES(2)

Fig no.	変更 Mod.	部品コード Parts no.	品名	Description	数量 Amt. Req.
S 101		M90409041	マルモクネジ 4.5X20	Wooden screw 4.5X20	2
S 102		M90632050	ザガネ 6	Washer 6	2
S 103		ME10E1776	ベルトカバー	Belt cover	1
S 104		ME10E0776	ベルトカバー	Belt cover	1
S 105		M91056004	SW-PW プラマイナネジ M4X10	Screw M4X10	4
S 106		MB60E0131	オイルパン	Oil pan	1
S 107		K14M95610701	ステップル	Staple	4
S 108		MF20A0130	アブラビン	Oil bottle	1
S 109		ME10A0797	ホコフィルム	Film sheet	1
S 110		M860A0FSW	フットスイッチ	Foot switch	1
S 111		MQ10A0734	ビニルカバー	Polyethylene cover	1
S 112		MG51A0201	ハインダー	Cord tie	1
S 113		MB60A0201	ハインダー	Cord tie	2
S 114		M90306041	マルモクネジ 3.1X16	Wooden screw 3.1X16	4
S 115		MB60A0420	コテイグ	Tie holder	2
S 116		MB60A2620	ナイロンクリップ AB-10N	Nylon clip AB-10N	1
S 117		MB60A1620	ナイロンクリップ AB-8N	Nylon clip AB-8N	1
S 118		MS10A0777	Vベルト M51	V-belt M51	1
S 119		M97319099	ケーブル (ニューリヨクシンコウ)	Cable (input signal)	1
S 120		M97320099	ケーブル (ソレノイド)	Cable (solenoid)	1
S 121		M97318099	ケーブル (サーボモータ用)	Cable (servo motor)	1
S 122		MB05A0376	クサリ	Chain	1
S 901		M97355099	ケーブル (パルスモータ)	Cable (pulse motor)	1

T オプションパーツ  
OPTION PARTS

---

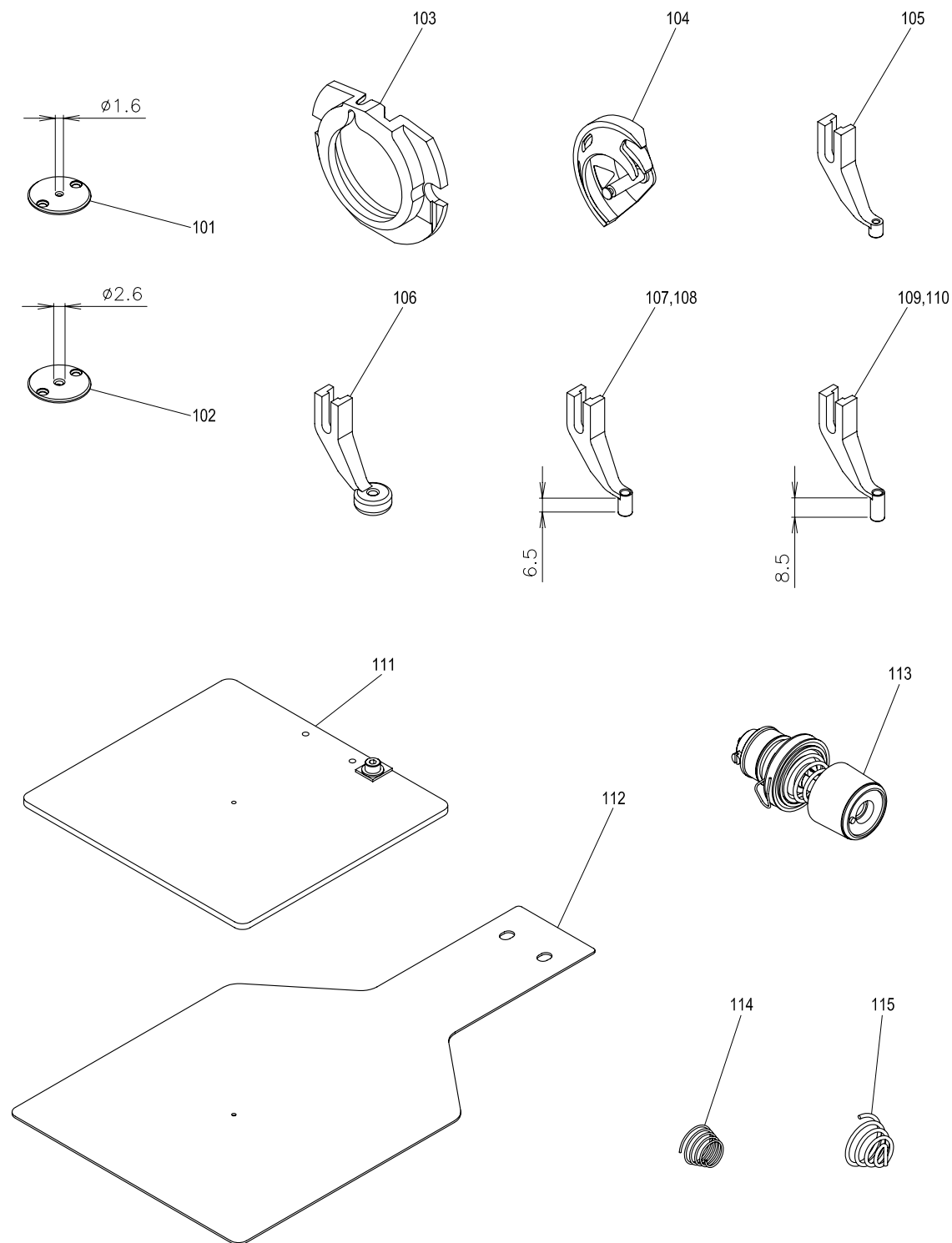

[T]オプションパーツ  
OPTION PARTS

Fig no.	変更 Mod.	部品コード Parts no.	品 名	Description	数量 Amt. Req.
T 101		MS03A0101	ハリイタ (ウスモノヨウ) φ 1.6	Needle plate (for light) φ 1.6	1
T 102		MS03A2101	ハリイタ (アツモノヨウ) φ 2.6	Needle plate (for heavy) φ 2.6	1
T 103		MS01A1616	ナカカマオサエ (アツモノヨウ)	Inner hook clamber (for heavy)	1
T 104		MS17A1120	ナカカマ (アツモノヨウ)	Inner hook (for heavy)	1
T 105		MV30A1256	ナカオサエ (ウスモノヨウ)	Presser foot (for light)	1
T 106		MV35A0106	サラオサエ	Presser foot	1
T 107		MS03A0256	ナカオサエ φ 3	Presser foot φ 3	1
T 108		MS03A1256	ナカオサエ φ 2	Presser foot φ 2	1
T 109		MA35A0256	ナカオサエ φ 3	Presser foot φ 3	1
T 110		MA35A1256	ナカオサエ φ 2	Presser foot φ 2	1
T 111		ME10E0272	オサエクミタテ (ソザイ)	Clamp frame complete (blank)	1
T 112		ME10A1272	オクリイタ (ソザイ)	Feed plate (blank)	1
T 113		MS04E1210	ウワイトチヨウセツキ (クミ)	Thread tension regulator assy	1
T 114		MF10A1245	エンスイハネ (プリテンションヨウ)	Spring (for pretension)	1
T 115		MN10A3245	エンスイハネ (ウワイトチヨウセツキヨウ)	Spring (for thread tension regulator)	1

索引  
INDEX-1

部品コード Parts No.	ページ Page	Fig No.	部品コード Parts No.	ページ Page	Fig No.	部品コード Parts No.	ページ Page	Fig No.	部品コード Parts No.	ページ Page	Fig No.
K14M71725402	** P27	** P 118	M90802002	** P19	** K 102	M91057004	** P3	** B 120	M91602046	** P5	** C 111
M800E2CON	** P27	** P 117	M90802003	** P23	** M 111	M91057020	** P5	** C 121	M91603003	** P21	** L 121
M82510FUS	** P31	** R 109	↑	** P9	** E 129	↑	** P23	** M 115	M91605045	** P5	** C 110
M860A0FSW	** P33	** S 110	M90806002	** P3	** B 117	M91058004	** P27	** P 106	M91606001	** P21	** L 129
M90001043	** P33	** S 107	M90809065	** P31	** R 128	M91058020	** P21	** L 113	↑	** P7	** D 133
M90001060	** P9	** E 128	M90815002	** P7	** D 130	M91059004	** P7	** D 103	M91652020	** P19	** K 146
M90101017	** P19	** K 152	M90817060	** P17	** J 114	M91060021	** P13	** G 114	M91688015	** P21	** L 109
M90102017	** P19	** K 138	M90818060	** P17	** J 124	M91066004	** P3	** B 115	M91689015	** P21	** L 107
M90105062	** P15	** H 145	M90823050	** P3	** B 109	M91069004	** P19	** K 118	M91801035	** P21	** L 101
M90110053	** P21	** L 166	M90853002	** P9	** E 126	M91071004	** P27	** P 122	M91802006	** P7	** D 132
↑	** P15	** H 144	M90859004	** P3	** B 138	↑	** P3	** B 139	M91802045	** P9	** E 105
M90204060	** P5	** C 101	M90875045	** P23	** M 109	M91083004	** P13	** G 131	↑	** P21	** L 102
M90306041	** P33	** S 114	M90901002	** P5	** C 102	M91101046	** P5	** C 139	M91803022	** P3	** B 112
M90307053	** P23	** M 108	M90901020	** P17	** J 103	M91102045	** P19	** K 164	M91910080	** P3	** B 107
M90316050	** P13	** G 121	M90906003	** P19	** K 127	M91104045	** P19	** K 150	M92003050	** P21	** L 165
M90317050	** P23	** M 107	↑	** P3	** B 137	M91108001	** P19	** K 162	M92004050	** P21	** L 164
↑	** P27	** P 110	M90908003	** P3	** B 123	M91109002	** P17	** J 104	M93001050	** P7	** D 106
M90325065	** P21	** L 128	↑	** P21	** L 115	↑	** P15	** H 108	M93003021	** P13	** G 108
M90330065	** P7	** D 105	M90920002	** P5	** C 141	M91109045	** P19	** K 158	M93004021	** P15	** H 138
M90406040	** P29	** Q 103	M90921002	** P13	** G 102	M91110002	** P3	** B 121	M93006050	** P9	** E 130
M90409041	** P33	** S 101	M90922002	** P21	** L 139	M91112002	** P19	** K 106	M93009020	** P13	** G 129
M90421050	** P7	** D 102	M90939002	** P5	** C 142	M91116002	** P21	** L 160	M93011021	** P27	** P 111
↑	** P17	** J 137	M90971004	** P27	** P 104	↑	** P15	** H 112	M93202045	** P21	** L 130
↑	** P19	** K 109	M90983002	** P17	** J 107	M91127015	** P15	** H 120	M93202047	** P21	** L 131
↑	** P21	** L 163	M90990002	** P21	** L 151	↑	** P19	** K 101	M94001001	** P11	** F 107
M90422050	** P17	** J 132	↑	** P7	** D 136	M91129015	** P19	** K 130	M94001021	** P15	** H 104
M90423060	** P21	** L 146	↑	** P19	** K 119	M91131002	** P21	** L 143	M94002017	** P21	** L 152
M90424053	** P19	** K 108	↑	** P3	** B 142	M91137015	** P15	** H 111	M94003017	** P13	** G 103
M90432060	** P21	** L 158	M90991002	** P13	** G 124	↑	** P17	** J 111	M94003021	** P13	** G 125
M90448037	** P11	** F 130	M91001075	** P11	** F 101	M91139015	** P17	** J 101	M94003099	** P27	** P 105
M90500085	** P9	** E 115	M91003022	** P13	** G 119	M91180080	** P3	** B 119	↑	** P25	** N 116
M90504053	** P11	** F 123	M91003070	** P11	** F 128	M91203002	** P9	** E 101	M94004099	** P25	** N 104
↑	** P19	** K 161	↑	** P17	** J 120	M91214015	** P19	** K 133	M94006017	** P17	** J 130
M90504065	** P21	** L 157	M91004045	** P13	** G 132	M91219015	** P21	** L 142	↑	** P11	** F 109
M90505065	** P15	** H 117	↑	** P19	** K 107	M91221001	** P9	** E 132	M94007017	** P17	** J 133
M90511050	** P17	** J 116	M91004067	** P5	** C 129	↑	** P7	** D 122	M94008017	** P13	** G 104
↑	** P19	** K 160	M91005067	** P5	** C 131	M91222001	** P9	** E 104	M94009021	** P17	** J 138
↑	** P15	** H 103	M91011004	** P3	** B 127	M91223001	** P7	** D 137	M94010070	** P15	** H 132
↑	** P11	** F 116	M91013004	** P3	** B 144	M91224001	** P19	** K 131	M94035021	** P13	** G 109
M90511065	** P11	** F 110	↑	** P5	** C 123	M91276004	** P3	** B 101	↑	** P17	** J 136
M90513065	** P31	** R 107	M91050020	** P17	** J 118	M91304080	** P3	** B 106	M95001001	** P11	** F 104
↑	** P19	** K 136	M91053020	** P3	** B 124	M91331004	** P19	** K 116	M95001017	** P11	** F 124
M90518060	** P15	** H 128	↑	** P7	** D 120	M91382045	** P19	** K 112	M95001021	** P9	** E 123
M90543060	** P15	** H 121	M91054004	** P3	** B 103	↑	** P15	** H 102	↑	** P15	** H 129
M90601064	** P5	** C 133	↑	** P23	** M 101	M91400010	** P3	** B 134	M95002017	** P21	** L 162
M90605010	** P19	** K 122	↑	** P15	** H 143	↑	** P17	** J 131	↑	** P17	** J 134
M90618060	** P15	** H 127	↑	** P25	** N 105	M91503001	** P9	** E 111	↑	** P15	** H 114
M90619060	** P15	** H 124	↑	** P27	** P 101	M91506001	** P21	** L 136	M95003021	** P19	** K 141
M90620060	** P15	** H 130	M91055020	** P5	** C 124	M91515022	** P21	** L 147	M95004017	** P11	** F 115
M90624053	** P31	** R 125	M91056004	** P27	** P 123	M91520002	** P7	** D 112	↑	** P17	** J 115
M90630050	** P31	** R 124	↑	** P33	** S 105	M91551015	** P21	** L 125	M95004020	** P3	** B 128
M90631050	** P15	** H 146	↑	** P21	** L 104	M91572045	** P21	** L 122	M95004021	** P9	** E 107
↑	** P21	** L 123	↑	** P23	** M 102	M91576045	** P31	** R 126	↑	** P19	** K 151
M90632050	** P33	** S 102	↑	** P19	** K 142	↑	** P19	** K 145	M95005017	** P19	** K 111
↑	** P21	** L 133	M91057004	** P27	** P 114	M91602001	** P7	** D 118	↑	** P17	** J 141

索引  
INDEX-2

部品コード Parts No.	ページ Page	Fig No.	部品コード Parts No.	ページ Page	Fig No.	部品コード Parts No.	ページ Page	Fig No.	部品コード Parts No.	ページ Page	Fig No.
M95008021	*** P15	*** H 101	MB60A0476	*** P11	*** F 113	ME10A0339	*** P3	*** B 132	ME10A2601	*** P21	*** L 161
M95011021	*** P15	*** H 116	MB60A0477	*** P17	*** J 109	ME10A0352	*** P15	*** H 122	ME10A2729	*** P21	*** L 155
M95018021	*** P15	*** H 134	MB60A0523	*** P11	*** F 102	ME10A0390	*** P11	*** F 121	ME10A2780	*** P27	*** P 108
M95035021	*** P11	*** F 119	MB60A0560	*** P31	*** R 127	ME10A0408	*** P27	*** P 102	ME10A2910	*** P15	*** H 123
M95036021	*** P11	*** F 120	MB60A0601	*** P3	*** B 122	ME10A0426	*** P13	*** G 112	ME10A3339	*** P13	*** G 113
M95048021	*** P11	*** F 122	MB60A0694	*** P7	*** D 111	ME10A0429	*** P17	*** J 105	ME10A3910	*** P15	*** H 119
M95049021	*** P19	*** K 163	MB60A0719	*** P29	*** Q 104	ME10A0454	*** P15	*** H 131	ME10A4339	*** P13	*** G 107
M95060095	*** P11	*** F 108	MB60A0740	*** P9	*** E 102	ME10A0457	*** P17	*** J 122	ME10A4910	*** P15	*** H 125
M96002017	*** P31	*** R 123	MB60A0750	*** P3	*** B 110	ME10A0477	*** P13	*** G 110	ME10A5339	*** P13	*** G 120
M96002020	*** P9	*** E 114	MB60A0778	*** P11	*** F 114	ME10A0523	*** P11	*** F 127	ME10A5910	*** P15	*** H 126
M96004052	*** P19	*** K 129	MB60A0780	*** P15	*** H 142	ME10A0571	*** P11	*** F 106	ME10A6339	*** P17	*** J 129
M96020021	*** P31	*** R 122	MB60A0915	*** P23	*** M 105	ME10A0572	*** P21	*** L 105	ME10A6910	*** P21	*** L 110
M96033021	*** P15	*** H 139	MB60A0957	*** P13	*** G 126	ME10A0595	*** P29	*** Q 101	ME10A7910	*** P21	*** L 112
M97318099	*** P33	*** S 121	MB60A1368	*** P29	*** Q 105	ME10A0601	*** P17	*** J 135	ME10A8339	*** P15	*** H 140
M97319099	*** P33	*** S 119	MB60A1454	*** P11	*** F 111	ME10A0700	*** P17	*** J 110	ME10A9339	*** P27	*** P 107
M97320099	*** P33	*** S 120	MB60A1601	*** P5	*** C 128	ME10A0729	*** P17	*** J 126	ME10B0339	*** P3	*** B 136
M97355099	*** P33	*** S 901	MB60A1620	*** P33	*** S 117	ME10A0734	*** P33	*** S 111	ME10E0270	*** P23	*** M 901
M97356099	*** P23	*** M 103	MB60A1626	*** P21	*** L 140	ME10A0738	*** P21	*** L 148	ME10E0272	*** P35	*** T 111
M98003015	*** P9	*** E 108	MB60A1758	*** P11	*** F 117	ME10A0742	*** P3	*** B 105	ME10E0450	*** P9	*** E 117
M99002052	*** P17	*** J 112	MB60A1780	*** P25	*** N 128	ME10A0743	*** P15	*** H 118	ME10E0452	*** P9	*** E 902
M99006063	*** P21	*** L 114	MB60A1957	*** P13	*** G 130	ME10A0758	*** P11	*** F 126	ME10E0484	*** P27	*** P 103
↑	*** P5	*** C 126	MB60A1990	*** P31	*** R 106	ME10A0763	*** P21	*** L 111	ME10E0519	*** P15	*** H 115
MA04A0477	*** P13	*** G 118	MB60A2352	*** P27	*** P 116	ME10A0778	*** P11	*** F 131	ME10E0600	*** P5	*** C 117
MA04A1530	*** P5	*** C 120	MB60A2601	*** P13	*** G 106	ME10A0780	*** P27	*** P 124	ME10E0691	*** P31	*** R 902
MA10A0120	*** P9	*** E 121	MB60A2620	*** P33	*** S 116	ME10A0797	*** P3	*** B 141	ME10E0746	*** P19	*** K 117
MA10A0123	*** P9	*** E 119	MB60A2682	*** P11	*** F 103	↑	*** P33	*** S 109	ME10E0776	*** P33	*** S 104
↑	*** P31	*** R 102	MB60A3682	*** P11	*** F 112	ME10A0802	*** P15	*** H 137	ME10E0849	*** P3	*** B 108
MA10A0454	*** P15	*** H 107	MB60A3957	*** P29	*** Q 102	ME10A0850	*** P11	*** F 125	ME10E0975	*** P19	*** K 139
MA10A0455	*** P17	*** J 117	MB60A5339	*** P27	*** P 113	ME10A0910	*** P17	*** J 102	ME10E1484	*** P27	*** P 109
MA10A0601	*** P19	*** K 115	MB60A5601	*** P27	*** P 119	ME10A0950	*** P21	*** L 150	ME10E1519	*** P21	*** L 159
MA10A0729	*** P15	*** H 106	MB60A5780	*** P27	*** P 120	ME10A0956	*** P21	*** L 124	ME10E1688	*** P25	*** N 110
MA10A0950	*** P15	*** H 105	MB60A6780	*** P27	*** P 121	ME10A0957	*** P13	*** G 115	ME10E1776	*** P33	*** S 103
MA10A1613	*** P31	*** R 116	MB60E0131	*** P33	*** S 106	ME10A0972	*** P13	*** G 116	ME10E1830	*** P3	*** B 116
MA10A1950	*** P15	*** H 109	MB60E0150	*** P29	*** Q 901	ME10A0990	*** P31	*** R 901	ME10E2519	*** P19	*** K 144
MA10B2476	*** P19	*** K 125	MB60E0234	*** P7	*** D 904	ME10A1252	*** P21	*** L 144	ME10E2688	*** P25	*** N 111
MA16E0210	*** P5	*** C 901	MB60E0682	*** P7	*** D 113	ME10A1266	*** P17	*** J 113	ME10E3519	*** P19	*** K 114
MA20A0194	*** P5	*** C 127	MB60E0950	*** P5	*** C 125	ME10A1272	*** P35	*** T 112	ME10E3601	*** P23	*** M 104
MA20A0392	*** P19	*** K 134	MB60E0982	*** P23	*** M 113	ME10A1339	*** P3	*** B 133	ME10E3688	*** P25	*** N 118
MA20A0476	*** P5	*** C 118	MB60E1682	*** P7	*** D 901	ME10A1390	*** P11	*** F 105	ME10E4519	*** P23	*** M 106
MA20A0584	*** P3	*** B 125	MB60E1956	*** P9	*** E 901	ME10A1408	*** P27	*** P 112	ME10E4688	*** P25	*** N 119
MA20A0603	*** P19	*** K 113	MB60E3339	*** P23	*** M 902	ME10A1426	*** P13	*** G 105	ME10E5688	*** P25	*** N 120
MA20A0740	*** P9	*** E 113	MB62A0352	*** P3	*** B 102	ME10A1454	*** P17	*** J 125	ME10E6688	*** P25	*** N 121
MA35A0256	*** P35	*** T 109	MB62A4601	*** P3	*** B 143	ME10A1470	*** P3	*** B 140	ME10E7688	*** P25	*** N 122
MA35A1256	*** P35	*** T 110	ME03A0270	*** P23	*** M 117	ME10A1572	*** P15	*** H 141	ME10E8688	*** P25	*** N 123
MB02A0608	*** P31	*** R 118	ME03A8339	*** P3	*** B 145	ME10A1601	*** P17	*** J 123	ME10E9688	*** P25	*** N 127
MB02A1608	*** P31	*** R 117	ME10A0105	*** P17	*** J 140	ME10A1758	*** P15	*** H 113	ME10F0688	*** P25	*** N 129
MB05A0376	*** P33	*** S 122	ME10A0148	*** P9	*** E 112	ME10A1780	*** P25	*** N 101	ME20A0406	*** P7	*** D 101
MB18A0479	*** P31	*** R 113	ME10A0230	*** P7	*** D 121	ME10A1810	*** P21	*** L 153	ME25A0530	*** P5	*** C 122
MB18A1479	*** P31	*** R 112	ME10A0257	*** P15	*** H 136	ME10A1833	*** P21	*** L 149	ME25A0551	*** P5	*** C 140
MB60A0196	*** P17	*** J 139	ME10A0261	*** P21	*** L 103	ME10A1910	*** P15	*** H 110	ME25A0950	*** P5	*** C 119
MB60A0201	*** P33	*** S 113	ME10A0266	*** P17	*** J 108	ME10A1956	*** P21	*** L 118	ME25E0190	*** P5	*** C 903
MB60A0366	*** P27	*** P 115	ME10A0267	*** P15	*** H 133	ME10A2252	*** P21	*** L 154	MF00A0181	*** P5	*** C 135
MB60A0407	*** P13	*** G 111	ME10A0272	*** P17	*** J 142	ME10A2339	*** P13	*** G 101	MF00A0553	*** P5	*** C 136
MB60A0419	*** P31	*** R 104	ME10A0307	*** P17	*** J 128	ME10A2390	*** P11	*** F 129	MF00A0608	*** P31	*** R 119
MB60A0420	*** P33	*** S 115	ME10A0308	*** P17	*** J 127	ME10A2454	*** P21	*** L 156	MF00A1352	*** P17	*** J 106

索引  
INDEX-3

部品コード Parts No.	ページ Page	Fig No.	部品コード Parts No.	ページ Page	Fig No.	部品コード Parts No.	ページ Page	Fig No.	部品コード Parts No.	ページ Page	Fig No.
MF00A2780	*** P25	*** N 106	MN60A0620	*** P3	*** B 104	MS03A1910	*** P19	*** K 137			
MF00E0550	*** P5	*** C 904	MN60A0750	*** P19	*** K 110	MS03A2101	*** P35	*** T 102			
MF01A0181	*** P7	*** D 131	MN70A1780	*** P21	*** L 116	MS03A2780	*** P25	*** N 113			
MF01A0259	*** P7	*** D 107	MN72A1694	*** P7	*** D 109	MS03A3980	*** P23	*** M 116			
MF01A0476	*** P7	*** D 110	MS01A0121	*** P9	*** E 125	MS03A6154	*** P21	*** L 106			
MF01A0565	*** P31	*** R 108	MS01A0160	*** P3	*** B 113	MS03B0838	*** P19	*** K 128			
MF01A1476	*** P7	*** D 108	MS01A0192	*** P19	*** K 135	MS03E0662	*** P7	*** D 134			
MF10A0149	*** P31	*** R 121	MS01A0329	*** P9	*** E 127	MS03E0981	*** P23	*** M 112			
MF10A0181	*** P3	*** B 130	MS01A0348	*** P19	*** K 147	MS04E1210	*** P35	*** T 113			
MF10A0187	*** P5	*** C 105	MS01A0350	*** P7	*** D 124	MS07A0228	*** P19	*** K 105			
MF10A0267	*** P21	*** L 137	MS01A0361	*** P3	*** B 135	MS08A0454	*** P19	*** K 156			
MF10A0325	*** P7	*** D 135	MS01A0383	*** P7	*** D 905	MS08A0616	*** P9	*** E 120			
MF10A0553	*** P5	*** C 104	MS01A0508	*** P9	*** E 106	MS08A0692	*** P17	*** J 121			
MF10A0555	*** P5	*** C 106	MS01A0572	*** P9	*** E 131	MS08A0708	*** P19	*** K 154			
MF10A0709	*** P5	*** C 103	MS01A0611	*** P9	*** E 122	MS09A0950	*** P9	*** E 124			
MF10A1245	*** P35	*** T 114	MS01A0660	*** P7	*** D 126	MS10A0232	*** P7	*** D 903			
MF10A1555	*** P5	*** C 137	MS01A0663	*** P7	*** D 125	MS10A0688	*** P25	*** N 108			
MF10A2740	*** P25	*** N 102	MS01A0740	*** P25	*** N 115	MS10A0777	*** P33	*** S 118			
MF20A0130	*** P33	*** S 108	MS01A0761	*** P9	*** E 116	MS10A0976	*** P31	*** R 114			
MF21D0181	*** P7	*** D 128	MS01A0833	*** P9	*** E 103	MS10A1456	*** P3	*** B 111			
MF36A0245	*** P5	*** C 138	MS01A0891	*** P9	*** E 109	MS10A1740	*** P7	*** D 115			
MF36A0750	*** P19	*** K 103	MS01A1392	*** P19	*** K 159	MS14A0180	*** P5	*** C 115			
MF36A1180	*** P3	*** B 131	MS01A1476	*** P19	*** K 124	MS14A0350	*** P5	*** C 130			
MF40E0193	*** P31	*** R 105	MS01A1572	*** P19	*** K 148	MS14A0416	*** P15	*** H 135			
MF60A0700	*** P21	*** L 126	MS01A1616	*** P35	*** T 103	MS14A0472	*** P19	*** K 120			
MF60A0742	*** P25	*** N 103	MS01A1740	*** P25	*** N 112	MS14A0553	*** P5	*** C 114			
MF60A2740	*** P7	*** D 123	MS01A1976	*** P31	*** R 111	MS14A0572	*** P5	*** C 132			
MF60A5740	*** P25	*** N 125	MS01A2392	*** P19	*** K 157	MS14A0682	*** P7	*** D 119			
MF70A0350	*** P21	*** L 145	MS01A2572	*** P19	*** K 155	MS14A0740	*** P25	*** N 126			
MF70A0352	*** P7	*** D 117	MS01A3352	*** P19	*** K 901	MS14A0781	*** P11	*** F 132			
MF70A1180	*** P3	*** B 129	MS01A5454	*** P19	*** K 132	MS14A0838	*** P19	*** K 126			
MF80A0780	*** P25	*** N 114	MS01A8796	*** P25	*** N 109	MS14A0972	*** P13	*** G 128			
MF90A0361	*** P19	*** K 104	MS01A9796	*** P25	*** N 130	MS14A3601	*** P19	*** K 143			
MG30A0664	*** P7	*** D 127	MS01E0351	*** P19	*** K 149	MS14A3780	*** P25	*** N 124			
MG30A0740	*** P21	*** L 117	MS01E0430	*** P19	*** K 140	MS14A4454	*** P17	*** J 119			
MG30A0760	*** P21	*** L 901	MS01E0580	*** P7	*** D 902	MS14A4957	*** P13	*** G 117			
MG30A0833	*** P21	*** L 120	MS01E0975	*** P19	*** K 153	MS14E0180	*** P5	*** C 902			
MG30B0226	*** P21	*** L 108	MS02A0128	*** P31	*** R 101	MS17A0125	*** P9	*** E 118			
MG30B0740	*** P21	*** L 127	↑	*** P7	*** D 129	MS17A1120	*** P35	*** T 104			
MG43A0181	*** P3	*** B 126	MS02A0463	*** P21	*** L 902	MT60A0802	*** P5	*** C 109			
MG50A0740	*** P7	*** D 114	MS02A3477	*** P13	*** G 123	MV30A0256	*** P21	*** L 141			
MG51A0201	*** P33	*** S 112	MS02A4477	*** P13	*** G 127	MV30A1256	*** P35	*** T 105			
MG75A0265	*** P21	*** L 135	MS02E0460	*** P21	*** L 119	MV35A0106	*** P35	*** T 106			
MG75A1476	*** P5	*** C 116	MS02E0983	*** P23	*** M 110	MV88A0740	*** P7	*** D 116			
MM10A1479	*** P31	*** R 120	MS03A0101	*** P35	*** T 101						
MM11A0245	*** P5	*** C 113	MS03A0181	*** P31	*** R 110						
MM11A0352	*** P9	*** E 110	MS03A0256	*** P35	*** T 107						
MM11A0556	*** P5	*** C 107	MS03A0262	*** P21	*** L 138						
MM11A0702	*** P5	*** C 112	MS03A0417	*** P31	*** R 103						
MN10A0135	*** P25	*** N 107	↑	*** P5	*** C 134						
MN10A1456	*** P7	*** D 104	MS03A0703	*** P21	*** L 132						
MN10A3245	*** P35	*** T 115	MS03A1101	*** P19	*** K 123						
MN25A0479	*** P31	*** R 115	MS03A1256	*** P35	*** T 108						
MN52A1245	*** P5	*** C 108	MS03A1530	*** P23	*** M 114						
MN60A0620	*** P25	*** N 117	MS03A1572	*** P21	*** L 134						



MEMO

A series of horizontal dotted lines for writing.

MEMO

A series of horizontal dotted lines for writing.

 **三菱電機株式会社**

 **MITSUBISHI ELECTRIC CORPORATION**