

JUKI[®]
Union Special

Feed-off-the arm, 3-Needle, Double Chainstitch Machine

35800 Series

ENGINEER'S MANUAL

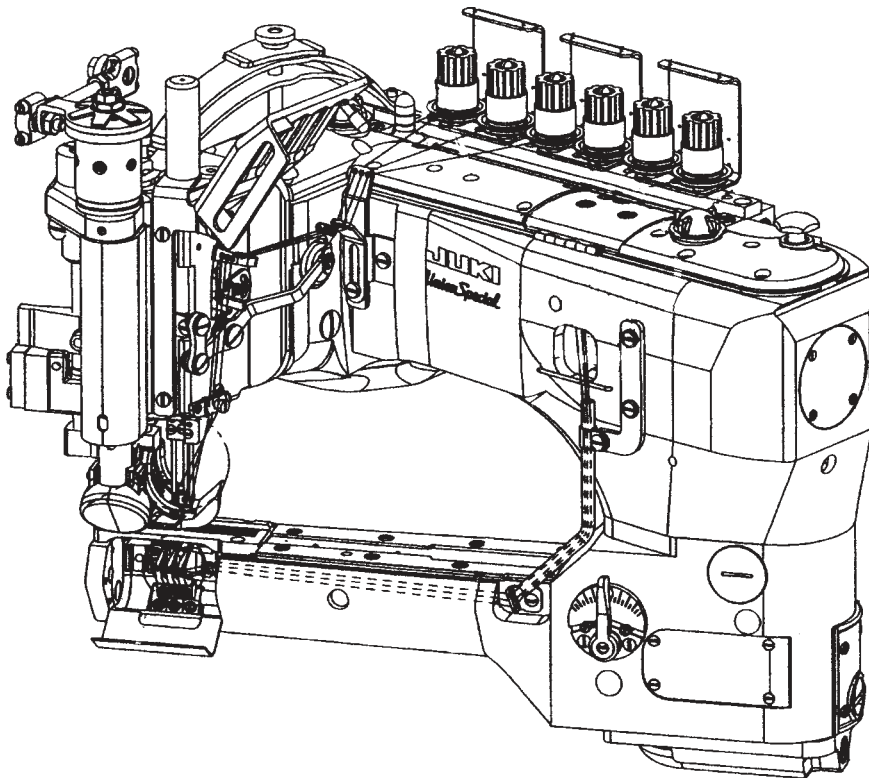

40052737
No.E376-00

Introduction

This Engineer's Manual is written for the technical personnel who are responsible for the service and maintenance of the machine.

The maintenance services to be done on this sewing machine should be based on this manual.

This manual gives the "Standard Adjustment" on the former section under which the most basic adjustment value is described and on the latter section the "Results of Improper Adjustment" under which stitching errors and troubles arising from mechanical failures and "How To Adjust" are described.

CONTENTS

1. Specifications	1
(1) Roller mechanism/clutch type	1
(2) Roller mechanism/belt type	2
2. Model list	3
(1) Model list using the roller mechanism of the clutch type	3
(2) Model list using the roller mechanism of the belt type	3
3. Description of US model code	5
4. Description of model code	6
5. Names of machine head	7
6. How to pass the threads	8
(1) Differential feed	8
(2) 1 piece feed	9
7. Standard adjustment	10
(1) How to remove the gauge components and upper feed roller (differential feed mechanism and 1 piece feed mechanism)	10
(2) Timing between the looper and needle bar	12
(3) Adjustment of the needle entry positions in the right-left and front-rear directions	14
(4) Looper adjustment	16
1) Looper return	16
2) Adjustment of the clearance between the looper and needle	16
(5) Adjustment of the needle bar height	18
(6) Adjustment of the looper motion paths	20
(7) Adjustment of rear needle guide	22
1) Longitudinal adjustment of the rear needle guide	22
2) Height adjustment of rear needle guide	22
(8) Adjustment of feed dog height and longitudinal movement (differential feed dog mechanism)	24
1) Height of main feed dog	24
2) Height of differential feed dog	24
3) Adjustment of longitudinal movement of main feed dog	24
4) Adjustment of vertical height of main feed dog and differential feed dog	24
5) Gradient of main feed dog and differential feed dog	24
(9) Adjustment of feed dog height and longitudinal movement (1 piece feed dog mechanism)	26
1) Height of main feed dog	26
2) Adjustment of longitudinal movement of main feed dog	26
(10) Adjustment of feed mechanisms	28
1) Adjustment of stitch length	28
2) Adjustment of differential feed amount	28
(11) Presser adjustment	30
1) Adjustment of amount of rise of presser	30
2) Adjustment of presser bar pressure	30
(12) Adjustment of upper feed roller	32
(13) Replacement of upper feed roller	34
(14) Adjustment of drawing amount of upper feed roller	36

(15) Adjustment of needle thread path	38
1) Height of needle thread adjusting path	38
2) Height of rocking take-up path	38
3) Height of needle thread guide adjuster	38
(16) Adjustment of bobbin thread cam	40
(17) Adjustment of tension disk rise	42
(18) Adjustment of air nozzle (air blow)	44
(19) Adjustment of folder	46
8. Lubrication	48
9. Folder types	49
10. Maintenance	50
(1) Spare parts	50
11. Part numbers and names of the modification parts for the 35800 Class – B8/B9 soft chain stitches (balloon stitches)	52
12. Troubles and corrective measures	53

1. Specifications

(1) Roller mechanism/clutch type

No.	Model Item	Specifications					
		35800DLU9	35800DNU8/9	35800DZ32/36	35800DRU8/9	35800PZ32/36	35800DWW8/9
1	Stitch type	3-needle, 6-thread, double chainstitch machine (401 LSc-3)					
2	Application	Denim, working clothes, felt, etc.					
3	Max. sewing speed	4500 rpm					
4	Sewing speed	3500 rpm					
5	Needle gauge	8 gauge: 3.2 mm, total width: 6.4 mm 9 gauge: 3.6 mm, total width: 7.2 mm					
6	Stitch length	2.1 to 3.6 mm (standard: 3.2 mm) at 1-inch intervals					
7	Needle (standard size)	UY130GS (standard) (Caution 1)					
		125 (#21)	140 (#24)				
8	Needle bar stroke	33mm					
9	Number of threads	6 pcs.					
10	External dimensions	H : 420 x W : 285 x D : 345 mm					
11	Machine head weight	23.5 kg					
12	Lifting amount of presser	9mm					10mm
13	Feed roller width	11.9mm					14.9mm
14	Feed roller shape	Standard (narrow type)	Inverted (narrow type)	Standard (narrow type)	Inverted (narrow type)	Standard (wide type)	
15	Feed adjustment	Main feed: Slide type stitch pitch adjusting system					
		Differential feed lever adjusting system			1 piece feed		Differential feed lever adjusting system
16	Lubrication	Automatic rotary pump lubrication system					
17	Lubricating oil	Union Special Spec 175 (ISO grade 22) or JUKI OIL SUP2000-1L					
18	Oil tank capacity	Front tank capacity: 70 to 80 ml Rear tank capacity: 60 to 70 ml					
19	Installation	Pedestal type Table and auxiliary drive type					
20	Working temperature/ humidity ranges	Temperature: 5 - 35°C, humidity: 35 - 85% (No dew condensation permissible)					
21	Supply voltage/frequency	Rated voltage $\pm 10\%$, 50/60Hz					

(Caution 1) Please be aware that many customers use the needle of UY128GLS with the needle size of 125 (No. 21) in Japan and check the needle number at shipment.

(2) Roller mechanism/belt type





















No.	Model Item	Specifications					
		35800BLW9	35800BQW8/9	35800BWDN8/9	35800BWDR8/9	35800BRWH9	35800BWW8/9
1	Stitch type	3-needle, 6-thread, double chainstitch machine (401 LSc-3)					
2	Application	Denim, working clothes, felt, etc.					
3	Max. sewing speed	4500rpm					
4	Sewing speed	3500rpm					
5	Needle gauge	8 gauge: 3.2 mm, total width: 6.4 mm 9 gauge: 3.6 mm, total width: 7.2 mm					
6	Stitch length	2.1 to 3.6 mm (standard: 3.2 mm) at 1-inch intervals					
7	Needle (standard size)	UY130GS (standard) (Caution 1)					
		125 (#21)	140 (#24)				
8	Needle bar stroke	33mm					
9	Number of threads	6 pcs.					
10	External dimensions	H : 420 x W : 285 x D : 345 mm					
11	Machine head weight	23.5kg					
12	Feed roller width	14.9mm					
13	Feed roller shape	Standard (wide type)			Rubber (wide type)		Standard (wide type)
14	Lifting amount of presser	9mm					10mm
15	Feed adjustment	Main feed: Slide type stitch pitch adjusting system					
		Differential feed lever adjusting system	1 piece feed		Differential feed lever adjusting system	1 piece feed	
16	Lubrication	Automatic rotary pump lubrication system					
17	Lubricating oil	Union Special Spec 175 (ISO grade 22) or JUKI OIL SUP2000-1L					
18	Oil tank capacity	Front tank capacity: 70 to 80 ml Rear tank capacity: 60 to 70 ml					
19	Installation	Pedestal type Table and auxiliary drive type					
20	Working temperature/ humidity ranges	Temperature: 5 - 35°C, humidity: 35 - 85% (No dew condensation permissible)					
21	Supply voltage/frequency	Rated voltage $\pm 10\%$, 50/60Hz					

(Caution 1) Please be aware that many customers use the needle of UY128GLS with the needle size of 125 (No. 21) in Japan and check the needle number at shipment.

























2. Model list

The standard model is the feed-off-the-arm 3-needle, double chainstitch machine for double lap seam

(1) Model list using the roller mechanism of the clutch type

No.	Model	Application	Needle Number of needles 3 pieces as standard	Number of threads 6 pieces as standard	Needle gauge 8ga-3.2mm 9ga-3.6mm	Number of stitches (mm) 8 stitches as standard	Differential motion	Lifting amount of presser	Upper puller drive	Roller width 	Roller shape 	Optional roller  	Presser width (front view)	Unevenness of throat plate	Feed shape (side view) 	Standard type folder 	Sewing speed (rpm)	Max. sewing speed (rpm)
1	35800DNU8	Double lap seam, hip overlapped seam (Denim fabric of 10 to 14 oz.)	130GS (140) 2-3	4-6	3.2+3.2 6.4mm	2.1 to 3.6mm (at 1-inch intervals) 7 to 12 stitches	Yes	9mm	Clutch type	11.9mm	Standard type narrow roller (35875AV)	Inverted type narrow roller (35875AW) Rubber type narrow roller (35826EF)				23420 AY18-1/8	3500	4500
2	35800DNU9	For medium-weight to heavy-weight materials			3.6+3.6 7.2mm													
3	35800DZ32	Double lap seam, hip overlapped seam (Denim fabric of 10 to 14 oz.)	130GS (140) 2-3	4-6	3.2+3.2 6.4mm	2.1 to 3.6mm (at 1-inch intervals) 7 to 12 stitches	Yes	9mm	Clutch type	11.9mm	Inverted type narrow roller (35875AW)	Standard type narrow roller (35875AW) Rubber type narrow roller (35826EF)				23420 AY18-1/8	3500	4500
4	35800DZ36	For medium-weight to heavy-weight materials			3.6+3.6 7.2mm													
5	35800DRU8	Double lap seam Denim (denim fabric of 10 to 14 oz.)	130GS (140) 2-3	4-6	3.2+3.2 6.4mm	2.1 to 3.6mm (at 1-inch intervals) 7 to 12 stitches	No	9mm	Clutch type	11.9mm	Standard type narrow roller (35875AV)	Inverted type narrow roller (35875AW) Rubber type narrow roller (35826EF)				23420 AY18-1/8	3500	4500
6	35800DRU9	For medium-weight to heavy-weight materials			3.6+3.6 7.2mm													
7	35800PZ32	Double lap seam Denim (denim fabric of 10 to 14 oz.)	130GS (140) 2-3	4-6	3.2+3.2 6.4mm	2.1 to 3.6mm (at 1-inch intervals) 7 to 12 stitches	No	9mm	Clutch type	11.9mm	Inverted type narrow roller (35875AW)	Standard type narrow roller (35875AW) Rubber type narrow roller (35826EF)				23420 AY18-1/8	3500	4500
8	35800PZ36	For medium-weight to heavy-weight materials			3.6+3.6 7.2mm													
9	35800DWW8	Double lap seam/high throw feed eccentric mechanism Denim (denim fabric of 15 to 14 oz.), felt, etc.	130GS (140) 2-3	4-6	3.2+3.2 6.4mm	2.1 to 3.6mm (at 1-inch intervals) 7 to 12 stitches	Yes	10mm	Clutch type	14.9mm	Standard type wide roller (35826X)	Inverted type wide roller (35826CB) Rubber type wide roller (35826DZ)				23420 AY18-1/8	3500	4500
10	35800DWW9	For heavy-weight to extra-heavy-weight materials			3.6+3.6 7.2mm													

(2) Model list using the roller mechanism of the belt type

No.	Model	Application	Needle Number of needles 3 pieces as standard	Number of threads 6 pieces as standard	Needle gauge 8ga-3.2mm 9ga-3.6mm	Number of stitches (mm) 8 stitches as standard	Differential motion	Lifting amount of presser	Upper puller drive	Roller width 	Roller shape 	Optional roller  	Presser width (front view)	Unevenness of throat plate	Feed shape (side view) 	Standard type folder 	Sewing speed (rpm)	Max. sewing speed (rpm)
1	35800BLW9	Double lap seam, denim (denim fabric of 6 to 9 oz.), working clothes, working pants, etc	130GS (125) 2-3	4-6	3.6+3.6 7.2mm	2.1 to 3.6mm (at 1-inch intervals) 7 to 12 stitches	Yes	9mm	Belt type	14.9mm	Standard type narrow roller (35826X)	Inverted type wide roller (35826CB) Rubber type wide roller (35826DZ)				23420 AY18-1/8	3500	4500
		For light-weight to medium-weight materials			3.2+3.2 6.4mm													
2	35800BQW8	Double lap seam, denim (denim fabric of 6 to 9 oz.), jacket, working clothes, etc.	130GS (125) 2-3	4-6	3.2+3.2 6.4mm	2.1 to 3.6mm (at 1-inch intervals) 7 to 12 stitches	No	9mm	Belt type	14.9mm	Standard type narrow roller (35826X)	Inverted type wide roller (35826CB) Rubber type wide roller (35826DZ)				23420 AY18-1/8	3500	4500
3	35800BQW9	For light-weight to medium-weight materials			3.6+3.6 7.2mm													
4	35800BWDN8	Double lap seam, denim (denim fabric of 10 to 14 oz.)	130GS (140) 2-3	4-6	3.2+3.2 6.4mm	2.1 to 3.6mm (at 1-inch intervals) 7 to 12 stitches	Yes	9mm	Belt type	14.9mm	Standard type narrow roller (35826X)	Inverted type wide roller (35826CB) Rubber type wide roller (35826DZ)				23420 AY18-1/8	3500	4500
5	35800BWDN9	For medium-weight to heavy-weight materials			3.6+3.6 7.2mm													
6	35800BWDR8	Double lap seam, denim (denim fabric of 10 to 14 oz.)	130GS (140) 2-3	4-6	3.2+3.2 6.4mm	2.1 to 3.6mm (at 1-inch intervals) 7 to 12 stitches	No	9mm	Belth type	14.9mm	Inverted type narrow roller (35875AW)	Inverted type wide roller (35826CB) Rubber type wide roller (35826DZ)				23420 AY18-1/8	3500	4500
7	35800BWDR9	For medium-weight to heavy-weight materials			3.6+3.6 7.2mm													
8	35800BRWH9	Double lap seam, (denim fabric of 10 to 14 oz.)	130GS (140) 2-3	4-6	3.6+3.6 7.2mm	2.1 to 3.6mm (at 1-inch intervals) 7 to 12 stitches	No	9mm	Belt type	14.9mm	Standard type wide roller (35826X)	Standard type wide roller (35826X) Rubber type wide roller (35826CB)				23420 AY18-1/8	3500	4500
		For medium-weight to heavy-weight materials			3.2+3.2 6.4mm													
9	35800BWW8	Double lap seam/high throw feed eccentric mechanism Denim (denim fabric of 15 to 14 oz.), felt, etc.	130GS (140) 2-3	4-6	3.2+3.2 6.4mm	2.1 to 3.6mm (at 1-inch intervals) 7 to 12 stitches	No	10mm	Belt type	14.9mm	Standard type narrow roller (35826X)	Inverted type wide roller (35826CB) Rubber type wide roller (35826DZ)				234-20 AY18-1/8	3500	4500
10	35800BWW9	For heavy-weight to extra-heavy-weight materials			3.6+3.6 7.2mm													

* In regard to the JUKI part numbers, refer to [10. Maintenance-(1) Spare parts.]

MEMO

3. Description of US model code

Model name: Feed-off-the-arm, 3-Needle, Double Chainstitch Machine

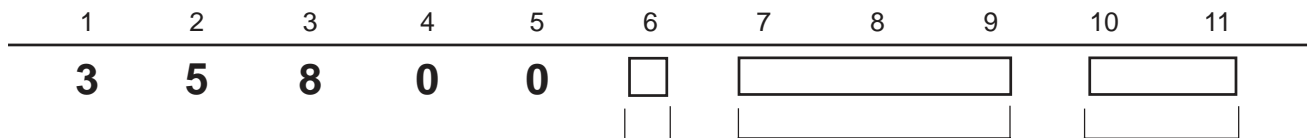

Code	Puller drive
B	Belt type
D	Clutch type (mechanical type)
P	Same as "D", only for PZ

Code	Classification of needle gauge
8	3.2mm
9	3.6mm
32	3.2mm
36	3.6mm

Code	Application and outline
LW	Differential feed mechanism/Double lap seam/For light- and medium-weight materials (denim fabric of 6 to 9 oz.)/1 mm of throat plate unevenness/Standard type wide roller equipped/Denim, jacket, working clothes, etc.
QW	Same as above, but 1 piece feed mechanism
WDN	Differential feed mechanism/Double lap seam/For medium- and heavy-weight materials (denim fabric of 10 – 14 oz.)/2.4 mm of throat plate unevenness/Standard type wide roller equipped/Denim, jacket, working clothes, etc.
WDR	Same as above, but 1 piece feed mechanism
RWH	Same as WDN, but rubber type wide roller equipped
NU	Differential feed mechanism/Double lap seam/For medium- and heavy-weight materials (denim fabric of 10 – 14 oz.)/2.4 mm of throat plate unevenness/Standard type narrow roller equipped/Denim, jacket, working clothes, etc.
RU	Same as above, but 1 piece feed mechanism
WW	Differential feed mechanism/Double lap seam/For heavy-weight materials (denim fabric of 15 – 16 oz.)/2.4 mm of throat plate unevenness/Standard type wide roller equipped/Denim, felt, etc.
Z	Same as DNU and DRU, but inverted type narrow roller equipped

4. Description of model code

Machine name: Feed-off-the-arm, 3-needle, double chainstitch machine

1 2 3 4 5 6 7 8 9 10 11 12 13 14 15

3 5 8 0 0 □ □ ◇ ◇ △ - **A A**

6 to 10		Name							
	Sewing material	Stitch count	Needle gauge	Differential motion		Puller drive	Roller width	Roller shape	Unevenness of throat plate
				Yes	No				
BLW 9	For light- and medium-weight materials (6 to 9 oz.), denim, working clothes, pants, etc.	3	3.6mm	●		Belt type	14.9mm	Steel gear	1.0mm
BQW 8		3	3.2mm		●				
BQW 9		3	3.6mm		●				
BWDN 8	For medium- and heavy-weight materials (10 to 14 oz.), denim, etc.	3	3.2mm	●		Belt type	14.9mm	Steel gear	2.4mm
BWDN 9		3	3.6mm	●					
BWDR 8		3	3.2mm		●				
BWDR 9		3	3.6mm		●				
BRWH 9		3	3.6mm		●				
DNU 8		3	3.2mm	●					
DNU 9		3	3.6mm	●		Clutch type	11.9mm	Steel gear	
DRU 8		3	3.2mm		●				
DRU 9		3	3.6mm		●				
DZ 32		3	3.2mm	●					
DZ 36	3	3.6mm	●						
PZ 32	3	3.2mm		●					
PZ 36	3	3.6mm		●	Steel gear (inverted)				
BWW 8	For extra-heavy-weight (15 to 16 oz.), denim, felt, etc.	3	3.2mm	●			Belt type	14.9mm	Steel gear
BWW 9		3	3.6mm	●					
DWW 8		3	3.2mm	●			Clutch type		
DWW 9		3	3.6mm	●					

5. Names of machine head

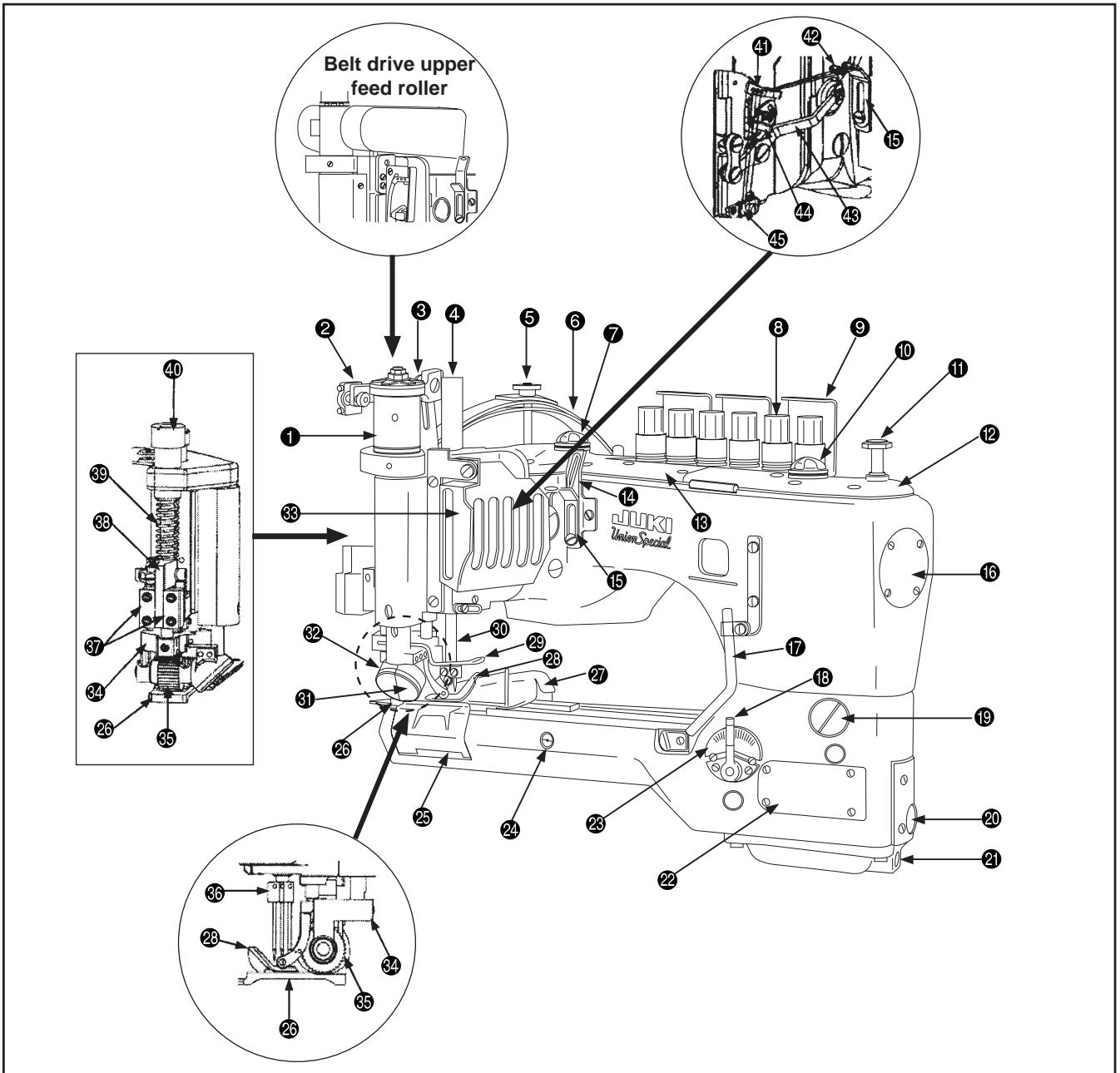

- | | | |
|---|---|---|
| ① Clutch drive upper feed roller | ⑩ Oil circulation inspection window (front) | ⑲ Window screw for stitch length adjustment |
| ② Clutch rod | ⑪ Loper push button | ⑳ Oil gauge (front) |
| ③ Clutch lever | ⑫ Front top cover | ㉑ Oil discharge screw (front) |
| ④ Cover for needle bar and roller | ⑬ Rear top cover | ㉒ Cylinder side cover |
| ⑤ Pressure regulating nut | ⑭ Needle thread guide path | ㉓ Gauge plate |
| ⑥ Pressure regulating plate spring assembly | ⑮ Needle thread adjusting path | ㉔ Feed rocking lever eccentric pin |
| ⑦ Oil circulation inspection window (rear) | | ㉕ Looper cover |
| ⑧ Thread tension knob | | ㉖ Throat plate |
| ⑨ Thread guide | | ㉗ Three folding device |
| | | ㉘ Presser |
| | | ㉙ Needle guard & needle cooling pipe |
| | | ㉚ Needle bar |
| | | ⑯ End cover |
| | | ⑰ Bobbin thread guide pipe |
| | | ⑱ Differential regulation lever |
| | | ㉑ Gear cover (front) |
| | | ㉒ Gear cover (rear) |
| | | ㉓ Swing guard |
| | | ㉔ Upper feed roller assembly |
| | | ㉕ Upper feed roller |
| | | ㉖ Needle clamp |
| | | ㉗ Right and left guide plates |
| | | ㉘ Guide finger |
| | | ㉙ Roller pressure regulating spring |
| | | ㉚ Roller pressure regulating screw |
| | | ㉛ Needle thread lever-thread guide |
| | | ㉜ Rocking balance thread guide |
| | | ㉝ Needle thread rocking balance |
| | | ㉞ Needle thread support adjuster |
| | | ㉟ Needle thread small tensioner |

6. How to pass the threads

(1) Differential feed

How to pass the needle threads and looper threads

1. Drawing of differential feed threading (sample model: 35800DNU & BWDN)

Needle thread: 1 for left needle thread, 2 for middle needle thread, 3 for right needle thread

Looper: 4 for front looper, 5 for middle looper, 6 for rear looper

Follow the drawing below to pass the threads.

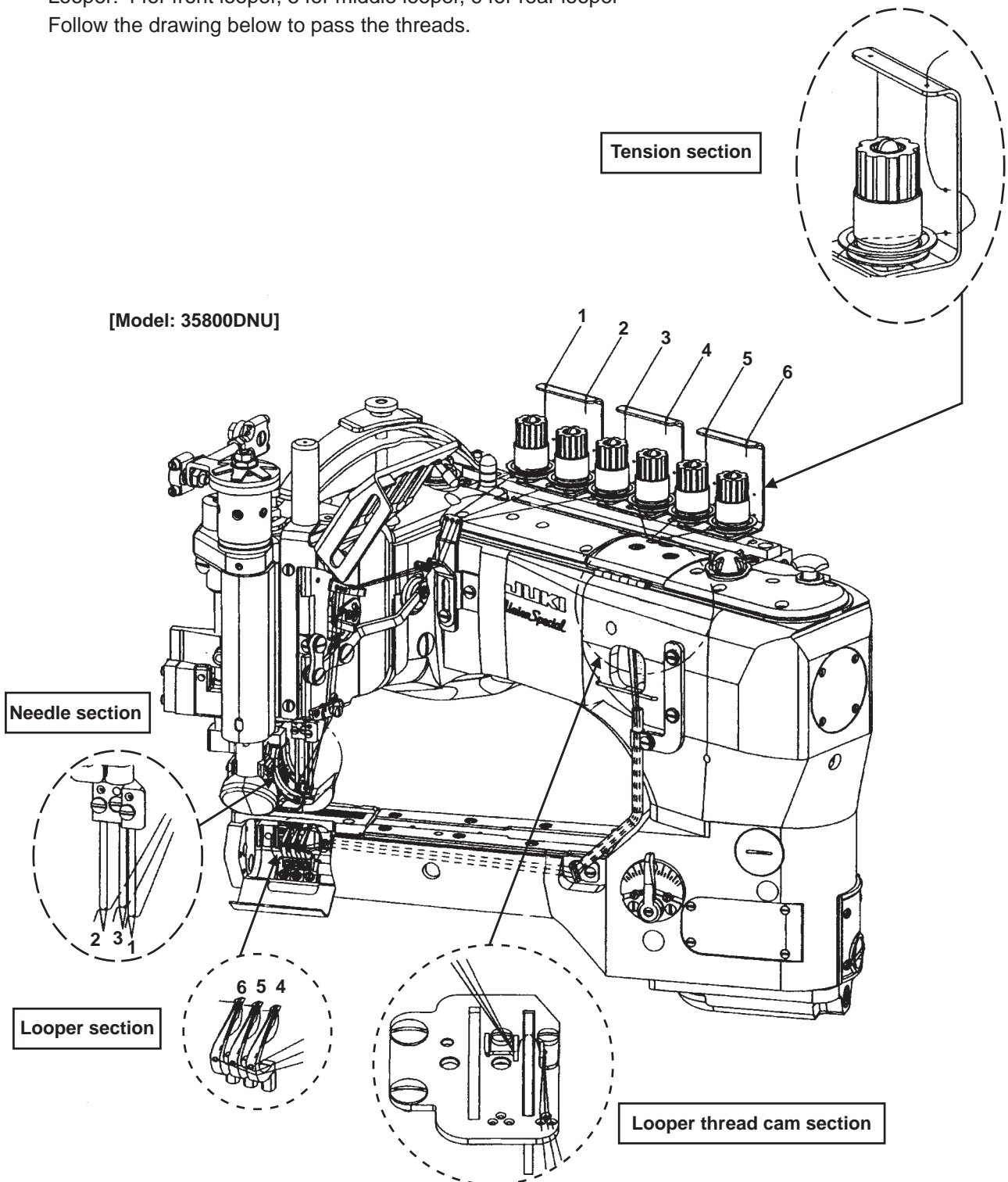

(2) 1 piece feed

How to pass the needle threads and looper threads

1. Drawing of 1 piece feed threading (sample model: 35800DRU & BWDR)

Needle thread: 1 for left needle thread, 2 for middle needle thread, 3 for right needle thread

Looper: 4 for front looper, 5 for middle looper, 6 for rear looper

Follow the drawing below to pass the threads.

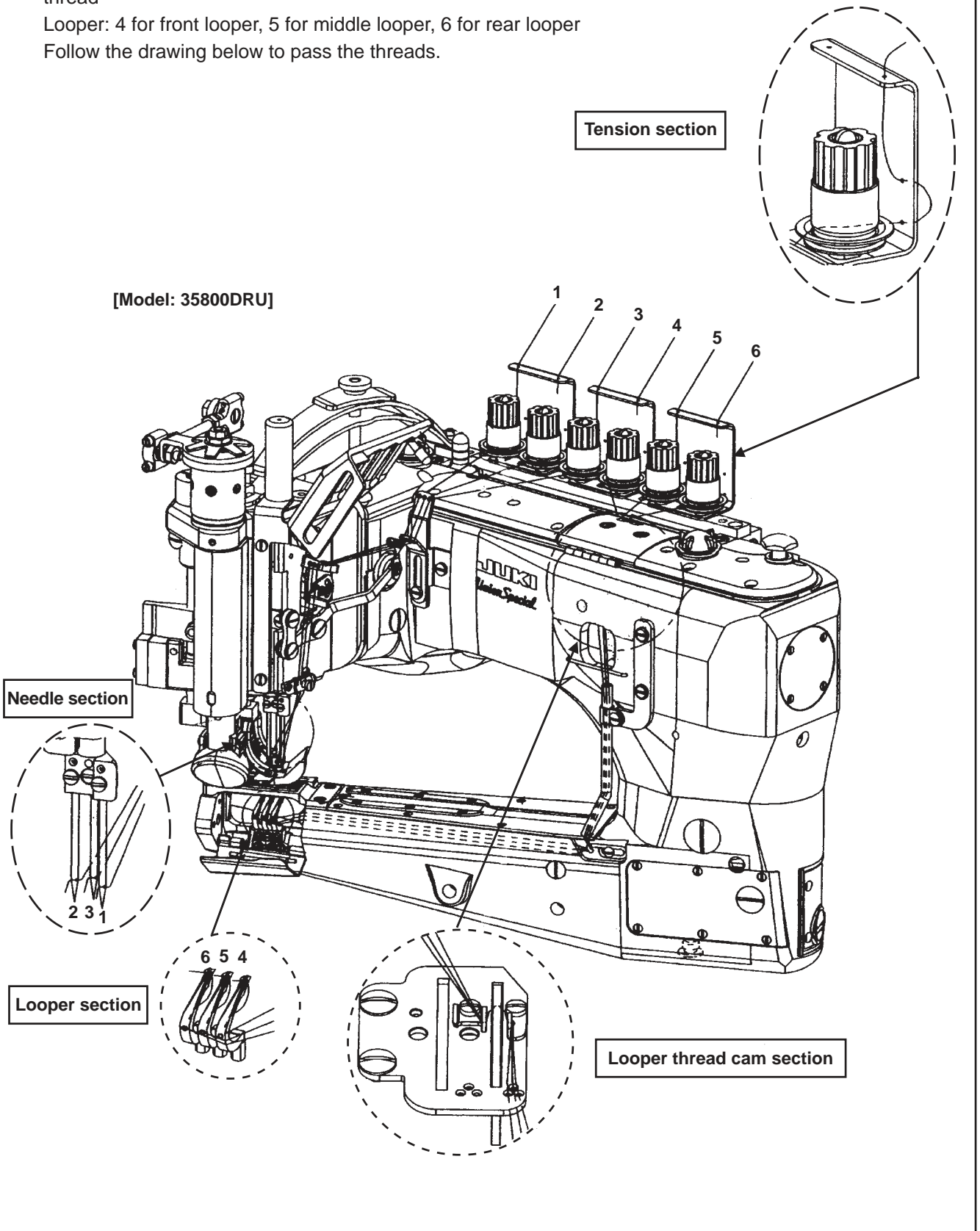

7. Standard adjustment

(1) How to remove the gauge components and upper feed roller (differential feed mechanism and 1 piece feed mechanism)

Disassembly procedure

1. Remove the gauge, its related parts (needle 16, presser yoke 19, throat plate 25, differential feed dog 27, and main feed dog 29), the cover, its related parts (cover for needle bar and roller 2 and looper cover 22), upper feed roller assembly 11, roller pressure regulating screw 6, and pressure regulating plate spring assembly 14 before adjustment.

(Caution) The directions of front, rear, right, and left during standard adjustment are based on the operator working position. Therefore, the forward rotation of the pulley is counterclockwise.

Left side of the machine head

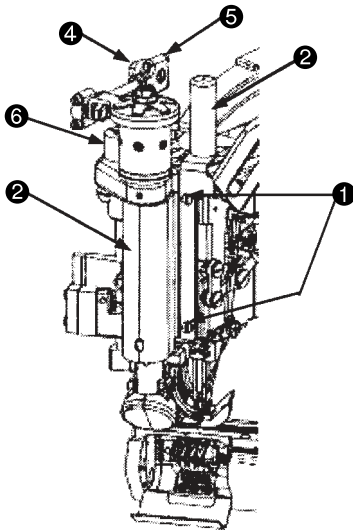

Rear side of the machine head

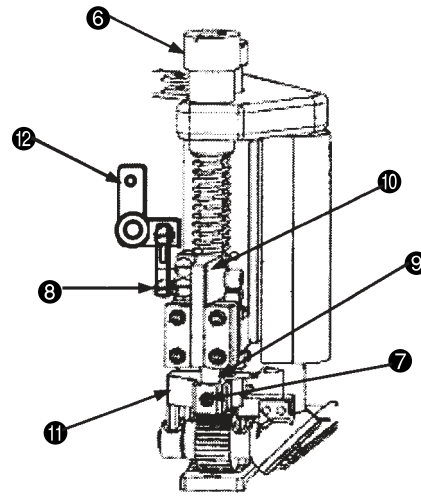

Right side of the machine head

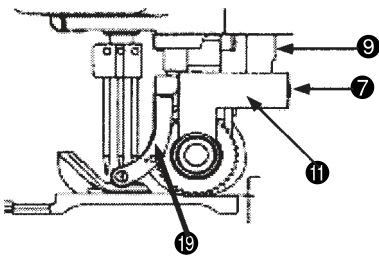

Pressure regulating plate spring and its related parts

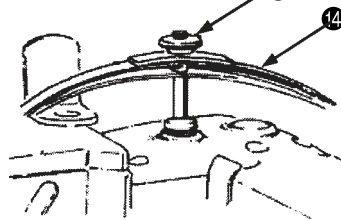

Left side of the machine head

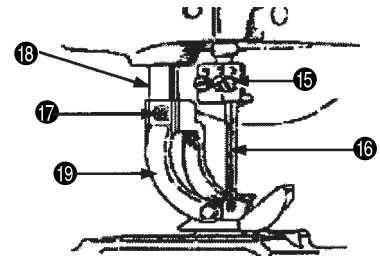

Gauge and its related parts (Differential feed mechanism)

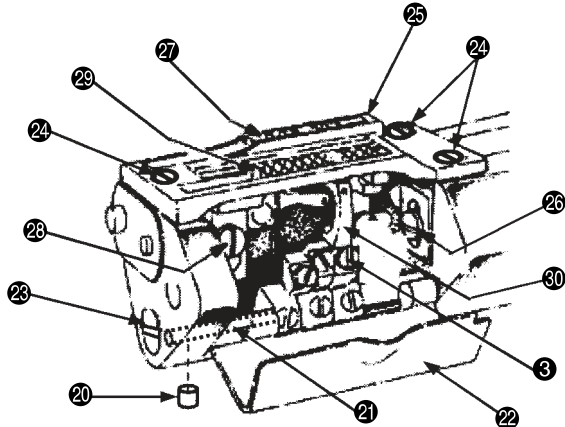

Gauge and its related parts (1 piece feed mechanism)

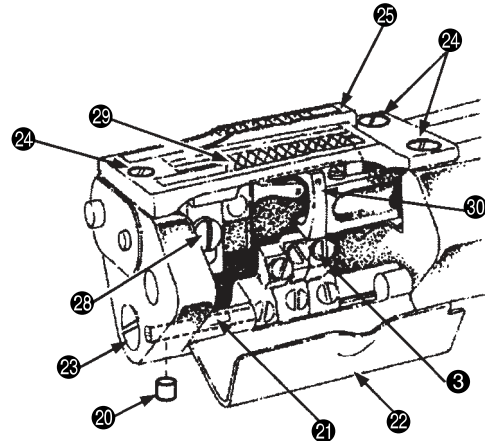

Disassembly procedure

Removal procedure of the gauge and upper feed roller

1. Loosen the setscrew ❶ and remove the needle bar and the roller cover ❷ together with the face cover and the packing, which are attached to the rear side.
2. Loosen the nut ❸ with a 3/8" spanner and remove the washer and clutch rod ❹.
3. Remove the roller pressure regulating screw ❺.
4. Loosen the setscrew ❻ securing the upper feed roller shaft with a 3/32" key wrench, remove the setscrew ❼ securing the link, lift the upper feed roller shaft ❽ and the guide finger ❾, and remove the upper feed roller assembly ❿.

(Caution) When the upper feed roller shaft ❽ is lifted, the guide finger ❾ interferes with the lift lever crank ❿. Therefore, remove the upper feed roller assembly ❿ after lifting the lift lever crank ❿ slightly.

5. Loosen the pressure regulating nut ❿ and remove the pressure regulating plate spring assembly ❿.
6. Loosen each setscrew ❿ that securing corresponding needles and remove three of each needle ❿.
7. Loosen the setscrew ❿ securing the presser yoke with a 5/64" or 2mm key wrench and remove the presser yoke ❿ after lifting the presser shaft ❿.
8. Loosen the setscrew ❿ with a 3/32" key wrench and remove the setscrew ❿ securing the cover. Removal of the setscrew allows you to remove the looper cover ❿ and spring stud ❿.
9. Loosen three setscrews ❿ securing the throat plate and remove the throat plate ❿.
10. Loosen the setscrew ❿ and remove the differential feed dog ❿.
11. Loosen the setscrew ❿ and remove the main feed dog ❿.
12. Loosen the setscrews ❿ securing the loopers ❿ and remove the loopers ❿.

(Caution) The disassembly procedure mentioned above mainly describes about the differential feed mechanism.

As to the 1 piece feed mechanism, the differential feed dog ❿ and setscrew ❿ are not provided.

(2) Timing between the looper and needle bar

Standard Adjustment

1. Timing between the looper and needle bar (synchronization)

Gauging equipment is mounted to perform synchronization adjustment.

The reference state is that there is no clearance between the bottom surface of the lower needle bar bushing ③ and the top surface of the timing gauge ④ when the steel rod ① touches the throat plate ② by rotating the pulley in the forward and backward directions. (Be sure to rotate the pulley in both directions to check the clearance.) The allowable clearance range is from 0 to 0.1 mm.

(Caution) The allowable clearance between the steel rod ① and the throat plate ② ranges from 0 to 0.1 mm when the bottom surface of the lower needle bar bushing ③ touches the top surface of the timing gauge ④ ahead of the other touch by rotating the pulley in both directions.

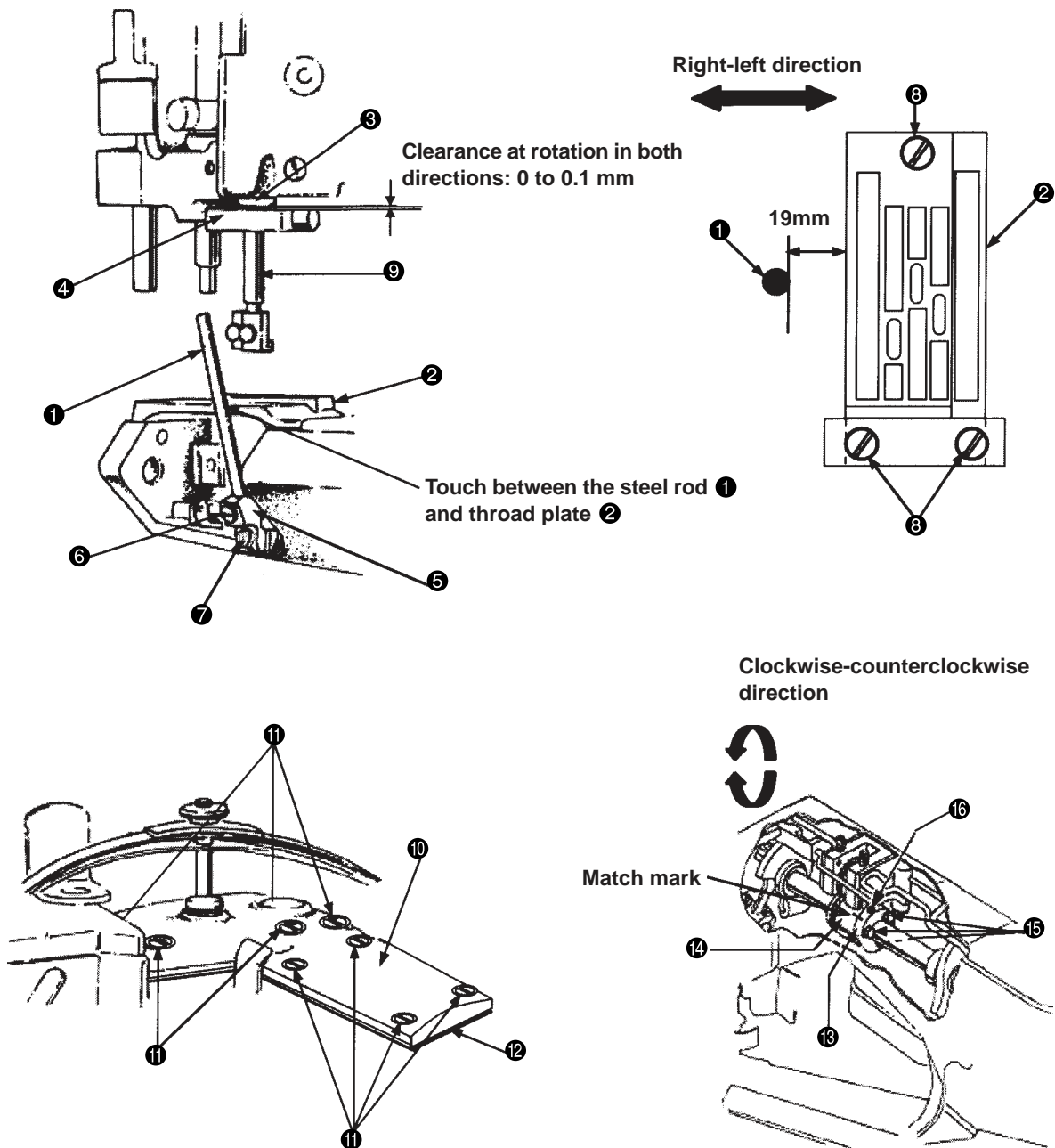

Adjustment Procedures	Results of Improper Adjustment
<p>1. How to install and use the synchronization adjustment gauge</p> <p>(1) Put the steel rod ❶ in the front looper base ❺ and tighten the setscrew ❸.</p> <p>(Caution) Use a key wrench (3 mm) instead of the steel rod ❶ if necessary.</p> <p>(2) Loosen the setscrew ❹ slightly and move the front looper base ❺ with the steel rod ❶ integrated to the most left position.</p> <p>(3) Install the throat plate ❷ and tighten the setscrew ❸.</p> <p>(4) Rotate the pulley to move the steel rod ❶ to the most left position, set the clearance between the right surface of the steel rod and the left surface of the throat plate ❷ to 19 mm, and tighten the setscrew ❹ securing the front looper base ❺.</p> <p>(5) Rotate the pulley counterclockwise and stop it when the steel rod ❶ touches the left surface of the throat plate ❷.</p> <p>(6) Mount the timing gauge ❹ to the needle bar ❻. Be sure to mount the timing gauge so that the top surface of the timing gauge ❹ touches the bottom surface of the lower needle bar bushing ❸.</p> <p>(Caution) Use a clip instead of the timing gauge ❹ if necessary.</p> <p>(7) When the pulley is rotated clockwise, the steel rod ❶ moves from side to side. Touch the steel rod with the left surface of the throat plate ❷ again. At this moment, make sure that the clearance between the bottom surface of the lower needle bar bushing ❸ and the top surface of the timing gauge ❹ is within the allowable range.</p> <p>(Caution) The bottom surface of the lower needle bar bushing ❸ may touch the top surface of the timing gauge ❹ ahead of the other touch. In such a case, make sure that the clearance between the steel rod ❶ and the throat plate ❷ is within the allowable range.</p> <p>(8) If the timing between the looper (steel rod ❶) and the needle bar ❻ is inappropriate, follow the procedure below.</p> <p>2. Corrective points and corrective measures</p> <p>(1) For adjusting the timing between the looper (steel rod ❶) and the needle bar ❻, loosen 9 setscrews ❿ securing the rear top cover ⓫ and remove the rear top cover ⓫ and the packing.</p> <p>(2) Loosen 3 fixing nuts ⓭ securing the front and rear main shaft couplings (⓮ and ⓯) and engage a key wrench (3/32") with the setscrew ⓰ to move the front main shaft coupling ⓮ in the clockwise-counterclockwise direction for adjustment while keeping the rear main shaft coupling ⓯ unmoved. (For the fixing nut ⓭, use a 1/4" spanner.)</p> <p>(Caution) 1. Align the match marks. 2. For moving the front main shaft coupling ⓮, temporarily tighten one of the fixing nuts ⓭, which is close to the match mark, and make an adjustment.</p> <ul style="list-style-type: none"> o To increase the clearance between the steel rod ❶ and throat plate ❷, rotate the front main shaft coupling ⓮ clockwise. o To decrease the clearance between the steel rod ❶ and throat plate ❷, rotate the front main shaft coupling ⓮ counterclockwise. <p>(3) After adjustment, put the rear top cover ⓫ and packing ⓬ back on and tighten the setscrew ❿.</p>	<ul style="list-style-type: none"> o Improper synchronization position adjustment may cause stitch skipping or thread breakage.

(3) Adjustment of the needle entry positions in the right-left and front-rear directions

Standard Adjustment

1. Needle entry

1) Needle entry position in the right-left direction

Mount 3 needles ② to the needle clamp ①. The standard needle entry position "A" in the right-left direction is the center of the needle hole of the throat plate ③.

2) Needle entry position in the front-rear direction

The standard needle entry position in the front-rear direction is decided under the condition that the clearance between the needle ② and needle hole of the throat plate ③, "B", is the same for all of 3 positions.

(Caution) Adjust the needle entry position in accordance with the temporary needle bar ④ height of 12.5 mm.

Refer to "(5) Adjustment of the needle bar height".

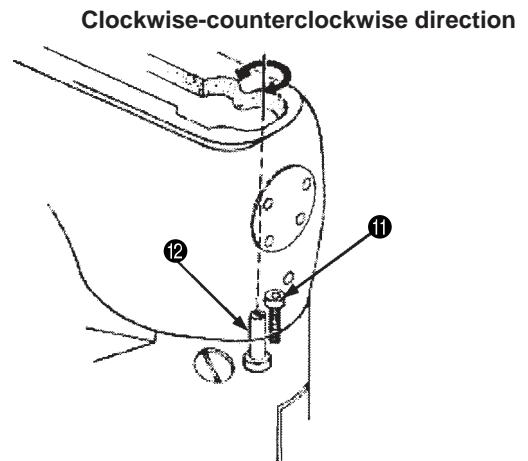
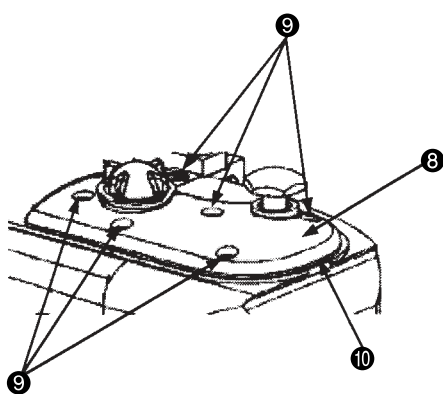
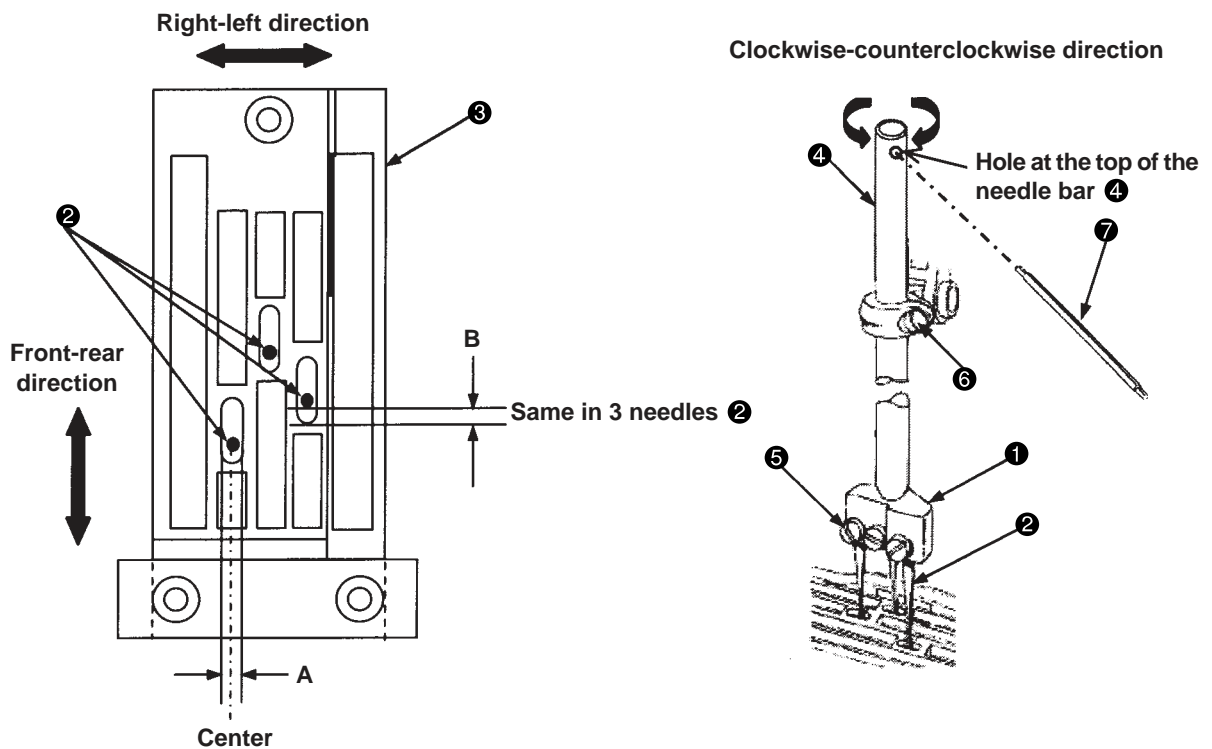

Adjustment Procedures	Results of Improper Adjustment
<p>1. Checking procedure of needle entry</p> <p>(1) Mount 3 needles ② to the needle clamp ① and tighten the setscrew ⑤.</p> <p>(2) Loosen the needle bar holding screw ⑥, set the temporary needle bar ④ height (12.5 mm), and tighten the needle bar holding screw {6} temporarily (approximately 4 turns of the needle bar ④).</p> <p>(3) Insert the torque rod ⑦ into the hole at the top of the needle bar ④ and rotate the needle bar ④ in the right-left direction to adjust the needle entry position in the front-rear and right-left directions.</p> <p>(Caution) 1. When the needle ② position is not in the center of the needle hole of the throat plate ③ in the right-left direction, follow the procedure below.</p> <p style="padding-left: 40px;">2. For needle entry adjustment, mount the rear needle guides temporarily and make sure that 3 needles ② touch evenly.</p> <p>2. Needle entry adjustment</p> <p>(1) For adjusting the needle entry position in the right-left direction, remove 6 setscrews ⑨ securing the front top cover ⑧ to remove the front top cover ⑧ and packing ⑩.</p> <p>(2) Loosen the hexagon head bolt ⑪, engage a driver with the eccentric pin ⑫, and rotate the driver in the right-left direction. Then, the cylinder arm moves in the right-left direction.</p> <p>(3) Adjust the needle entry position in the right-left direction.</p> <ul style="list-style-type: none"> o Rotation of the eccentric pin ⑫ clockwise moves the cylinder arm leftward. o Rotation of the eccentric pin ⑫ counterclockwise moves the cylinder arm rightward. <p>(4) After adjustments, tighten the hexagon head bolt ⑪.</p> <p>(5) After adjusting the needle entry position, put the front top cover ⑧ and packing ⑩ back on and tighten the setscrew ⑨.</p>	<ul style="list-style-type: none"> o Improper needle entry position adjustment may cause stitch skipping, needle breakage, or thread breakage.

(4) Looper adjustment

Standard Adjustment

1) Looper return

When each looper (①, ②, and ③) is at the most left position, the standard distance from the tip of each looper (①, ②, and ③) to the center of each needle (④, ⑤, and ⑥) is 3.6 mm (9/64").

1. Standardization of the front looper

When the front looper ① is at the most left position, measure the distance from the tip of the front looper ① to the center of the left needle ④ with the gauge ⑦ and a scale and adjust the distance to the standard value, i.e. 3.6 mm (9/64").

2. Standardization of middle and rear loopers

When the tips of the middle and rear loopers (② and ③) are simultaneously aligned with each left surface of the middle and right needles as well as the tip of the front looper ① with the left surface of the left needle ④, the middle and rear loopers are in the standard positions.

(Caution) For the front looper ①, the looper return is adjusted with the gauge ⑦ and a scale, and for the middle and rear loopers (② and ③), the looper return is adjusted by aligning the tips of the middle and rear loopers (② and ③) with the left surfaces of the needles (⑤ and ⑥), respectively.

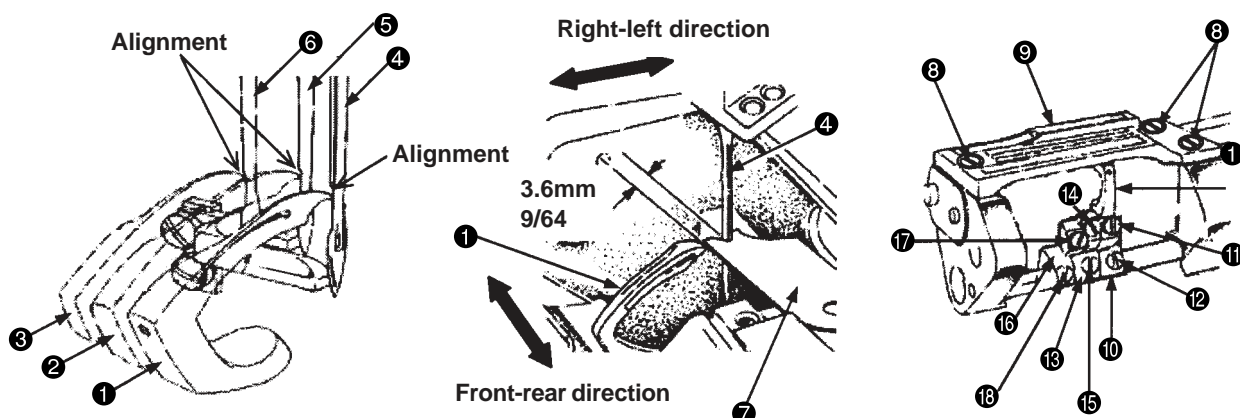

2) Adjustment of the clearance between the looper and needle

When the tips of each looper (①, ②, and ③) are at the center of each needle (④, ⑤, and ⑥), the standard clearance is 0.0mm (slight touch).

After adjusting the rear needle guide ⑱, make sure again that the clearance between the loopers (①, ②, and ③) and the needles (④, ⑤, and ⑥) is 0.0 mm respectively, and perform final adjustment of the clearance after threading.

(Caution) If clearance adjustment is performed without the rear needle guide ⑱, a little strongly touch the tips of the loopers (①, ②, and ③) with the needles (④, ⑤, and ⑥), respectively.

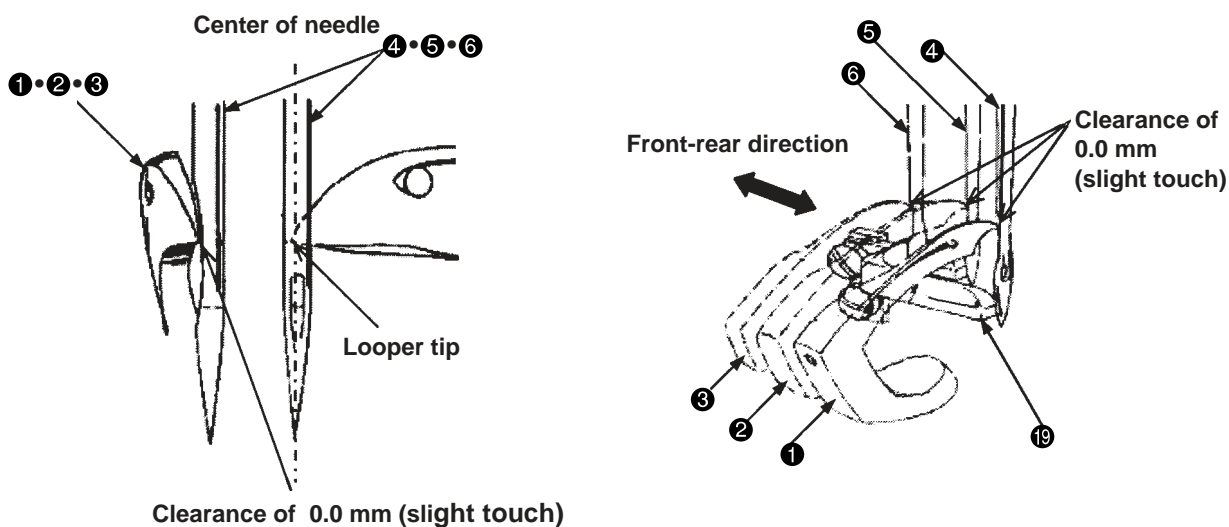

(5) Adjusting the height of the needle bar

Standard Adjustment

1. Height of the needle bar

- (1) Alignment between the bottom surface of the front looper and the top hole end of the left needle

When the pulley is rotated counterclockwise and the bottom surface of the front looper ① is aligned with the top hole end of the left needle ②, the standard needle bar height is achieved by adjusting the distance from the tip of the front looper ① to the right surface of the left needle ② to 0.8 mm.

- (2) Alignment between the tip of the front looper and the left surface of the left needle

When the pulley is rotated counterclockwise and the tip of the front looper ① is aligned with the left surface of the left needle ②, the standard needle bar height is achieved by adjusting the distance from the bottom surface of the front looper ① to the top hole end of the left needle ② to 1.6 mm.

(Caution) For adjusting the needle bar height, select an easier-to-adjust one from either (1) or (2) mentioned above.

- (3) Checking of the middle and rear looper heights shall be also checking of each looper return.

(Caution) 1. Needle entry adjustment is performed in accordance with the temporary needle bar height.

When the needle bar is at the upper dead point, the temporary clearance between the top surface of the throat plate ③ and the tips of the needles ② is 12.5 mm.

2. The needle bar height is temporarily adjusted for needle entry adjustment. If there is no problem with the needle bar height, readjustment of the needle bar height is not required. Advance to the next step.

Alignment between the bottom surface of the looper and the top hole end of the needle

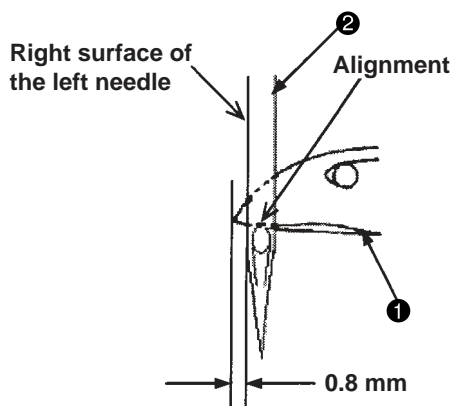

Alignment between the tip of the looper and the right surface of the needle

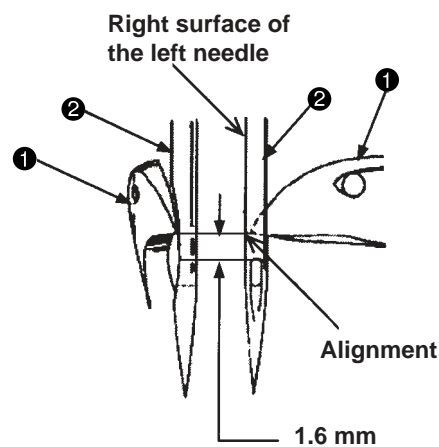

Temporary needle bar height

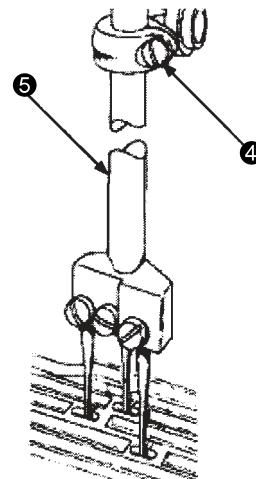
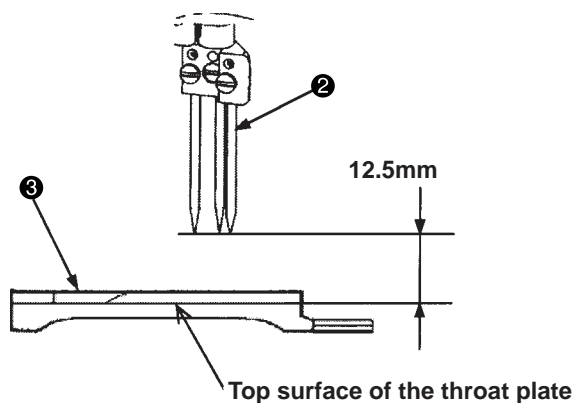

Adjustment Procedures	Results of Improper Adjustment
<p>1. Adjustment of the needle bar height</p> <p>(1) Remove the needle bar, roller cover, surface cover, and packing.</p> <p>(2) Loosen the setscrew ④ and adjust the needle bar ⑤ position vertically.</p> <p>(3) After adjustment, tighten the setscrew ④.</p> <p>(Caution) Use caution not to rotate the needle bar ⑤ at adjustment of needle bar height.</p> <p>Failure to observe this changes needle entry positions.</p>	<p>o Remarkably improper needle bar height adjustment may cause stitch skipping, needle breakage, or thread breakage.</p>

(6) Adjustment of the looper motion paths

Standard Adjustment

1. Looper momentum in the front-rear direction

- (1) The standard position of the front looper ① is decided under the condition that the tip of the needle ④ touches the rear of the front looper ① at 1/4" from the bottom surface when the pulley is rotated counterclockwise and the front looper ① is moved from right to left after mounting the front looper ① in a standard manner.
- (2) For the middle and rear loopers (② and ③), the standard position for each is decided under the same condition as the front looper, i.e. the tips of the needles (⑤ and ⑥) touch the rear of the loopers at 1/4" from the bottom surfaces, respectively.

(Caution) If the material has a thick unevenness during sewing, contact areas between the needle tips and the rear surfaces of the loopers (② and ③) may become smaller. (to prevent needle tip breakage)

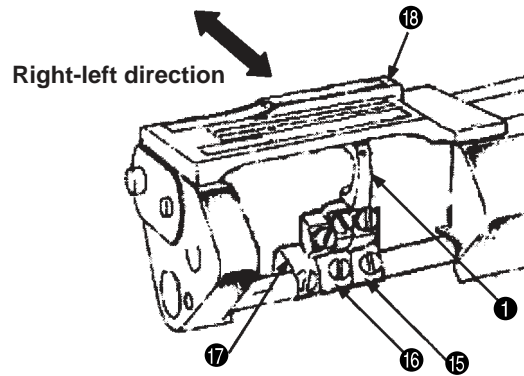
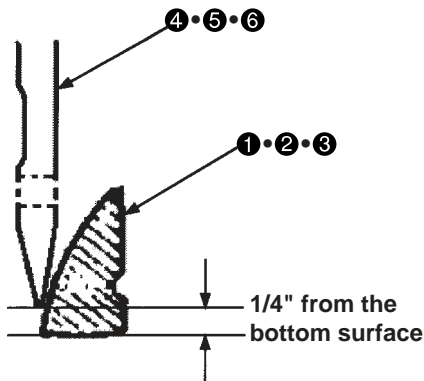

Differential feed model
Model: 35800DNU

1 piece feed model
Model: 35800DRU

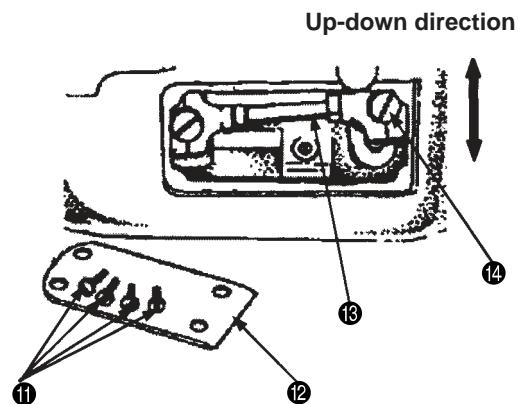
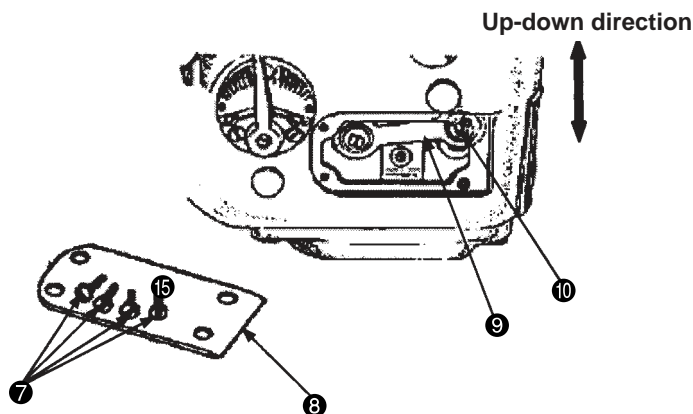

Adjustment Procedures	Results of Improper Adjustment
<p>1. Adjustment of longitudinal movement of differential feed looper</p> <p>(1) Loosen the setscrews ⑦ (4 pcs.) and remove the cylinder side cover ⑧.</p> <p>(2) Loosen the setscrew ⑩ of the ball joint ⑨ with a spanner wrench (TT85), and adjust the the forward/reverse movement by moving the setscrew ⑩ forward or backward.</p> <p>(3) After adjustments, mount the cylinder side cover ⑧, and tighten the setscrews ⑦.</p> <p>2. Adjustment of longitudinal movement of 1 piece feed looper</p> <p>(1) Loosen the setscrews ⑪ (4 pcs.) and remove the cylinder side cover ⑫.</p> <p>(2) Loosen the setscrew ⑭ of the ball joint ⑬ with a screwdriver, and adjust the the forward/reverse movement by moving the setscrew ⑭ forward or backward.</p> <p>(3) After adjustments, mount the cylinder side cover ⑫, and tighten the setscrews ⑪.</p> <ul style="list-style-type: none"> o When reducing the front and rear momentum amount of the looper, move the ball joints ⑨ and ⑬ upwards. o When increasing the front and rear momentum amount of the looper, move the ball joints ⑨ and ⑬ downwards. <p>(Caution) 1. When the front and rear momentum amount of the looper has been adjusted, move the respective looper bases ⑮, ⑯, and ⑰ and readjust the front/rear positions of the needles (④, ⑤, and ⑥) and the loopers (①, ②, and ③).</p> <p>2. When the above-mentioned adjustments are carried out, the throat plate ⑱ should be removed.</p>	<ul style="list-style-type: none"> o When the front and rear momentum amount of the looper is small: The amount of contact becomes large between tips of the needles (④, ⑤, and ⑥) and rear parts of the loopers (①, ②, and ③) and this can be a cause of needle tip being blunt. o When the front and rear momentum amount of the looper is large: The clearance becomes large between tips of the needles (④, ⑤, and ⑥) and rear parts of the loopers (①, ②, and ③) and this can be a cause of stitch skipping.

(7) Adjustment of rear needle guide

Standard Adjustment

1) Longitudinal adjustment of the rear needle guide

- When the pulley is turned counterclockwise and the rear needle holder ① advances to the most front position, it lightly touches the left needle ② and then tip of the front looper ③ passes. When tip of the front looper ③ reaches the position 1.5mm apart from the left side of the left needle ② while this front looper ③ moves in right direction, the standard position is that the needle tip comes in contact with the rear needle holder ①.
- The relationship between the middle needle ④ and the rear looper ⑤ and between the right needle ⑥ and the middle looper ⑦ is also required to assume the same conditions as 1. above in standard positioning.

(Caution) 1. The rear needle holder ① somewhat changes its contact position with the respective needles (②, ④, and ⑥) according to the needle entry position.

Recheck the needle entry condition for adjustments if the contact positions of the right and left needles (② and ⑥) seem to be different.

- To change the stitch length, readjustment of the front and rear positions is also needed for the rear needle holder ①.

2) Height adjustment of rear needle guide

- When tip of the front looper ③ coincides with the right side of the left needle ②, the standard dimension is 2.0mm between the lower position "A" of the needle hole and Point B of the rear looper ⑤.
- The relationship between the middle needle ④ and the rear looper ⑤ and between the right needle ⑥ and the middle looper ⑦ is also required to assume the same conditions as 1. above in standard positioning.

Longitudinal directions of rear needle guide

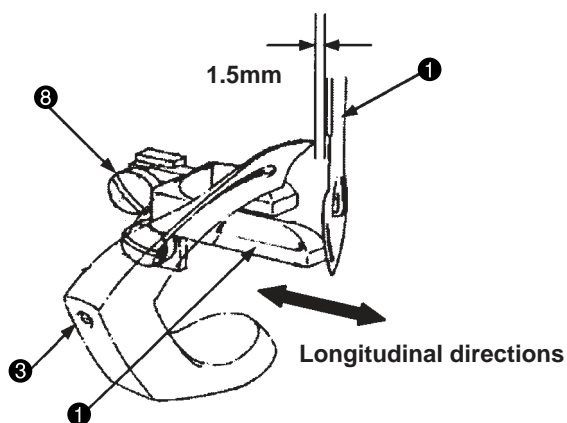

Vertical direction of rear needle guide

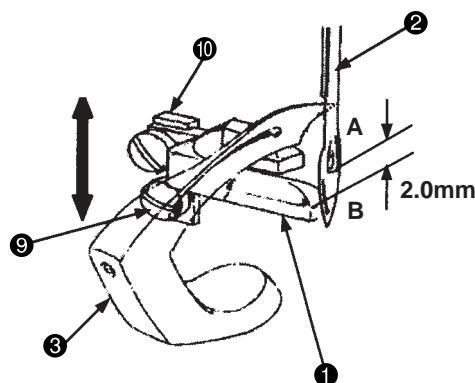

Right and left directions

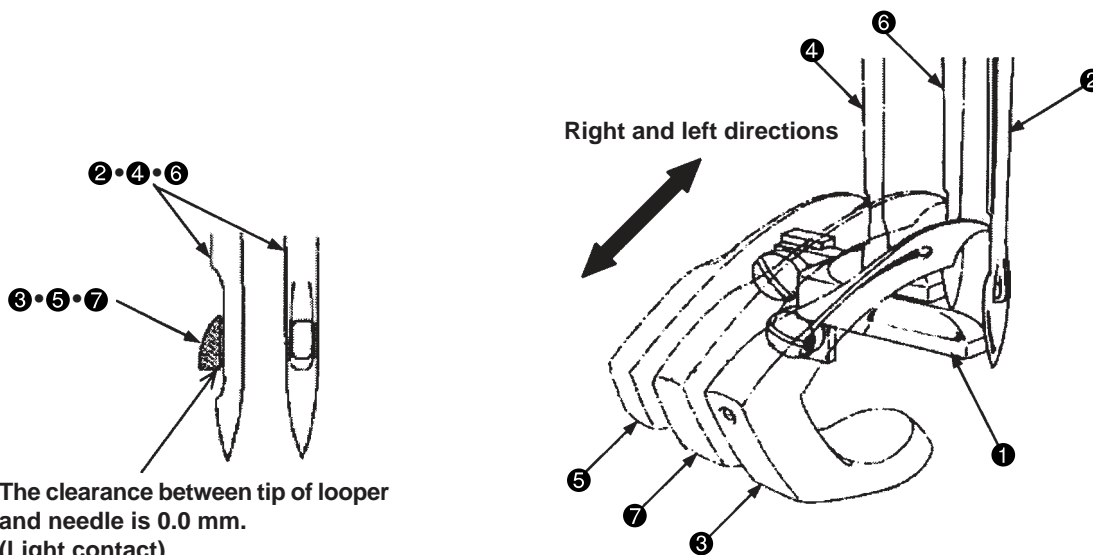

The clearance between tip of looper and needle is 0.0 mm.
(Light contact)

Adjustment Procedures	Results of Improper Adjustment
<p>1) Longitudinal adjustment of the rear needle guide</p> <ol style="list-style-type: none"> 1. Loosen the setscrew ⑧ and move the rear needle guide ① forward or backward to adjust the height. 2. After adjustments, tighten the setscrew ⑧. <p>(Caution) When the rear needle holder is adjusted, recheck the presence of a clearance between the respective needles (②, ④, and ⑥) and the respective loopers (③, ⑤, and ⑦). If any clearance is perceived, readjust the related conditions.</p> <p>2) Height adjustment of rear needle guide</p> <ol style="list-style-type: none"> 1. Loosen the setscrew ⑨ and move the rear needle guide base ⑩ vertically to adjust the height. 2. After adjustments, tighten the setscrew ⑨. 	<ul style="list-style-type: none"> o If a clearance is actually developed between the needles ②, ④, ⑥ and the rear needle holder ①, this can be a cause of needle breakage or stitch skipping. o When the rear needle holder ① presses the respective needles (②, ④, and ⑥) too much, this can be a cause of needle tip being blunt.

(8) Adjustment of feed dog height and longitudinal movement (differential feed dog mechanism)

Standard Adjustment

1) Height of main feed dog

The standard height is defined when the main feed dog ① attains the highest level and the root section of the main feed dog ① coincides with the upper face of the main feed dog throat plate ②.

2) Height of differential feed dog

The standard height of the differential feed dog ③ is defined when the main feed dog ① attains the highest level and a clearance of 0.05 to 0.1mm is secured between the upper face "A" of the main feed dog ① and the bottom face "B" of the differential feed dog ③.

3) Adjustment of longitudinal movement of main feed dog

The maximum amount of feed of the main feed dog ① is 3.6 mm. (Standard: 3.2 mm)

When the main feed dog ① attains its maximum feeding amount, the standard positioning is secured when Clearance "C" and Clearance "D" are equalized. Clearance "C" is defined as the distance from the feed groove front section of the throat plate ② to the front section of the main feed dog ① in position where the main feed dog ① stays in the most advanced position. Clearance "D" is defined as the distance from the feed groove rear section of the throat plate ② to the rear section of the main feed dog ① in position where the main feed dog ① has attained the most retreated position.

4) Adjustment of vertical height of main feed dog and differential feed dog

For the feed rocking lever eccentric pin ④ of the feed dog, the standard positioning of the driver groove is horizontal.

The vertical height of the main and differential feed dogs (① and ③) can be simultaneously adjusted by turning the feed rocking lever eccentric pin ④. Basically, however, this function should be used in standard position.

5) Gradient of main feed dog and differential feed dog

Front lowering condition is standard.

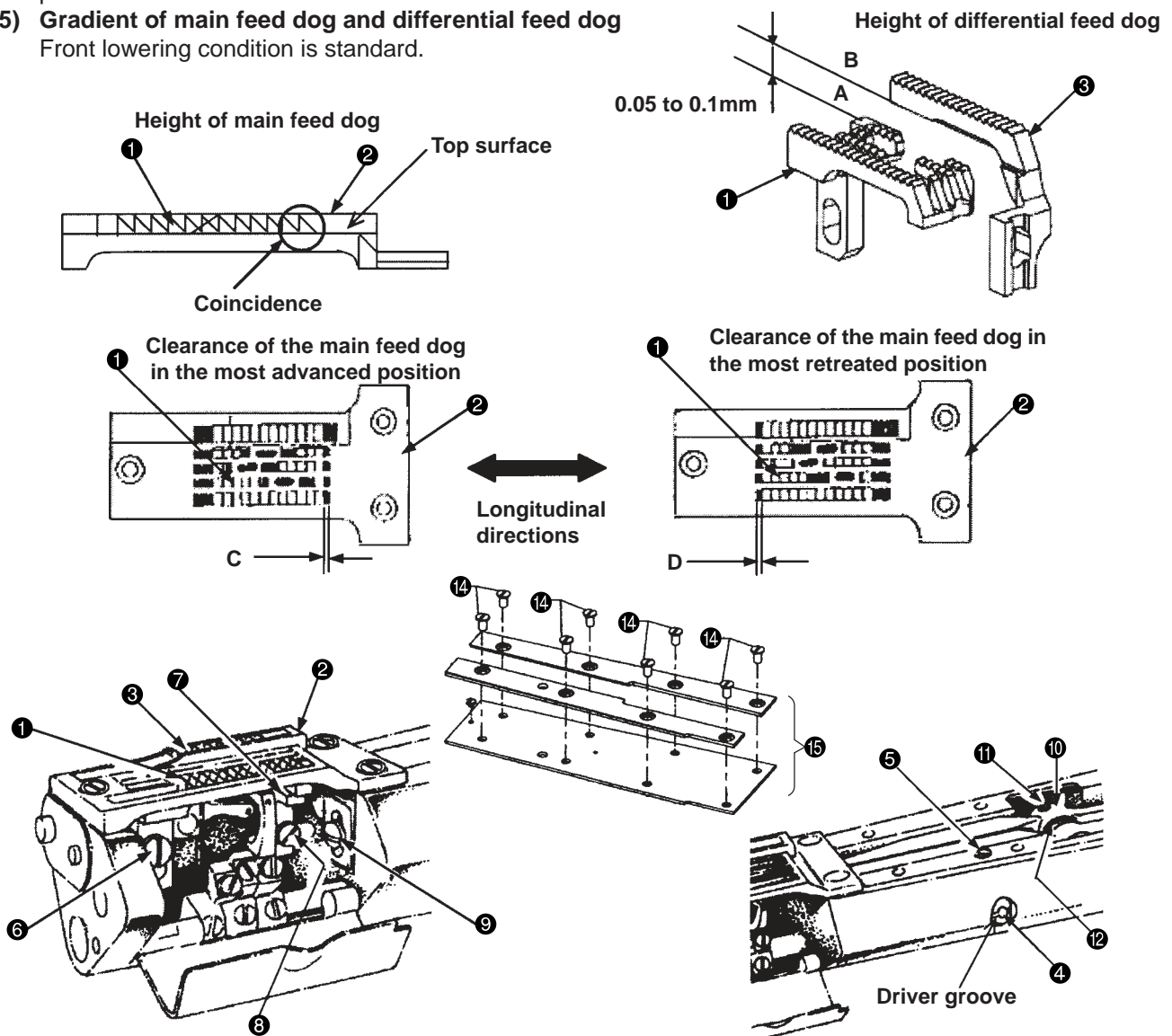

Adjustment Procedures	Results of Improper Adjustment
<p>Adjustment of main feed dog and differential feed dog</p> <ol style="list-style-type: none"> 1. For the feed rocking lever eccentric pin ④ of the feed dog, the standard positioning of the driver groove is horizontal. If the driver groove seems to be inclined deviating from the standard positioning, loosen the setscrew ⑤ and adjust the feed rocking lever eccentric pin ④ of the feed dog until it assumes its horizontal posture. Since then, tighten the setscrew ⑤. 2. Mount the main feed dog ①, differential feed dog ③ and throat plate ②, and fix the throat plate ②. 3. In the first place, adjust the height of the main feed dog ① to the standard position. Then fix it by tightening the setscrew ⑥. 4. Apply the feed dog support ⑦ to the bottom of the front section of the main feed dog ① and tighten the setscrew ⑧. 5. Then, adjust the height of the differential feed dog ③ to the standard position. After that, fix it by tightening the setscrew ⑨. 6. According to "(10) Feed adjustments, 1) Adjustment of stitch length", adjust the maximum feed amount of the main feed dog ① to 3.6mm. (Apply a ruler to the side of the main feed dog ① and confirm the result by turning the pulley counterclockwise.) 7. Turn the pulley counterclockwise and confirm that there is no contact between the main feed dog ① and the feed groove front/rear section of the throat plate ②. If there is any contact, loosen the setscrew ⑪ of the main feed rocking lever link ⑩ and turn the main feed rocking eccentric drive stud ⑫ to adjust the throat plate ② not to contact the feed groove front/rear section. After adjustments, tighten the setscrew ⑪. 8. After the front and rear momentum amount has been adjusted for the main feed dog ①, adjust the sewing length to the standard value of 3.2mm. <p>(Caution)</p> <ol style="list-style-type: none"> 1. In the case of front and rear adjustments of the differential feed dog mechanism, specific attention should be paid to the fine feed dog section of the main feed dog ①. 2. To make front and rear adjustments of the main feed dog ①, loosen eight setscrews ⑭ of the cylinder cover and remove the cylinder cover set ⑮. After adjustments, mount the cylinder cover set ⑮, and tighten the setscrews ⑭. 3. For the main feed dog ① and the differential feed dog ③, the longitudinal gradients and the horizontality are kept constant and cannot be adjusted. 	<p>When the height of feed dogs ①, ③ is insufficient</p> <ul style="list-style-type: none"> o The amount of feed is decreased and uneven feeding can occur. o When the height of the rear needle guide is lowered, this will cause breakage of a needle or stitch skipping. <p>When the height of feed dogs ①, ③ is excessive</p> <ul style="list-style-type: none"> o This can be a cause of the materials pushed back to the front side, or of giving rise to feed flaws. o When the height of the rear needle holder is raised and the margin of the needle contact position is increased, this will cause failure in producing loops and stitch skipping.

(9) Adjustment of feed dog height and longitudinal movement (1 piece feed dog mechanism)

Standard Adjustment

1) Height of main feed dog

The standard height is defined when the main feed dog ❶ attains the highest level and the rear root section of the main feed dog ❶ coincides with the upper face of the throat plate ❷ of the main feed dog ❶.

2) Adjustment of longitudinal movement of main feed dog

The maximum amount of feed of the main feed dog ❶ is 3.6 mm. (Standard: 3.2 mm)

When the main feed dog attains its maximum feeding amount, the standard positioning is secured when Clearance "A" and Clearance "B" are equalized. Clearance "A" is defined as the distance from the feed groove front section of the throat plate ❷ to the front section of the main feed dog ❶ in position where the main feed dog ❶ stays in the most advanced position. Clearance "B" is defined as the distance from the feed groove rear section of the throat plate ❷ to the rear section of the main feed dog ❶ in position where the main feed dog ❶ has attained the most retreated position. ($A = B$)

Height of main feed dog

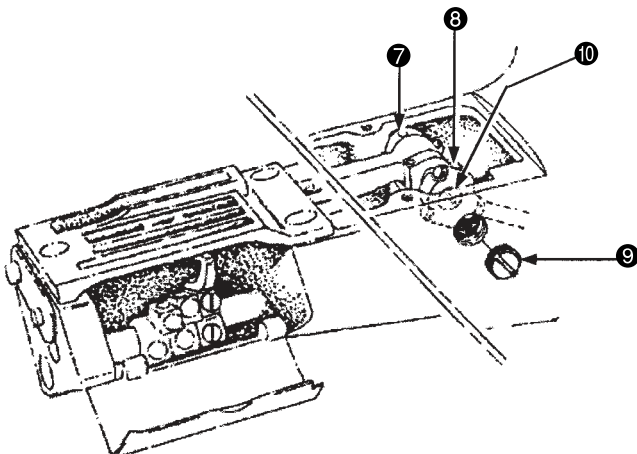
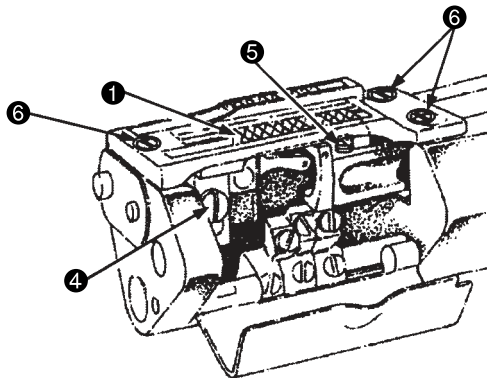
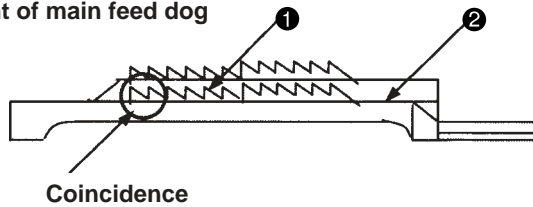

Clearance of the main feed dog in the most advanced position

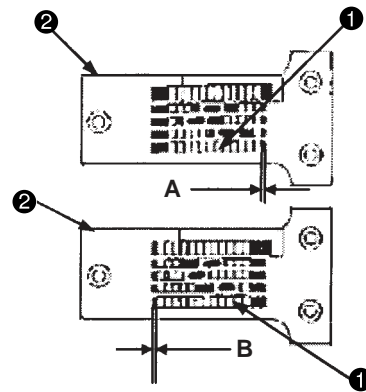

Clearance of the main feed dog in the most retreated position

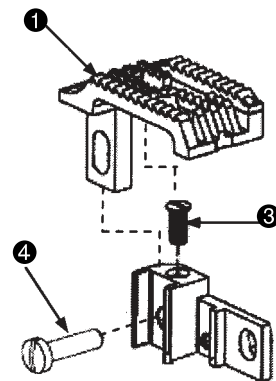

Adjustment Procedures	Results of Improper Adjustment
<p>1) Height of main feed dog</p> <ol style="list-style-type: none"> 1. Apply the rear support screw ③ to the bottom right of the main feed dog ①, tighten the setscrew ④, and mount the throat plate ②. 2. Check the standard height of the main feed dog. <ul style="list-style-type: none"> o If the main feed dog ① is low, raise the rear support screw ③. o If the main feed dog ① is high, raise the rear support screw ③. 3. Remove the throat plate ②, loosen the setscrew ④ to remove the main feed dog ①, and adjust height of the front support screw ⑤. 4. After adjustments, mount the main feed dog ①, tighten the setscrew ④, mount the throat plate ②, and tighten the setscrew ⑥. <p>2) Adjustment of longitudinal movement of main feed dog</p> <ol style="list-style-type: none"> 1. Loosen the setscrews (⑦ and ⑧) and remove the plug female screw ⑨. 2. Using a screwdriver, turn the eccentric pin ⑩ clockwise and counterclockwise until the front and rear positions of the main feed dog ① are properly adjusted. 	<p>When the height of main feed dog ① is insufficient</p> <ul style="list-style-type: none"> o The amount of feed is decreased and uneven feeding can occur. o When the height of the rear needle guide is lowered, this will cause breakage of a needle or stitch skipping. <p>When the height of main feed dog ① is excessive</p> <ul style="list-style-type: none"> o This can be a cause of the materials pushed back to the front side, or of giving rise to feed flaws. o When the height of the rear needle holder is raised and the margin of the needle contact position is increased, this will cause failure in producing loops and stitch skipping.

(10) Adjustment of feed mechanisms

Standard Adjustment

1) Adjustment of stitch length (standard: 8 stitches/inch interval)

The stitch length can be adjusted within the range of 2.1 mm to 3.6 mm. Standard adjustment is 3.2 mm. For the adjustment of the stitch length, loosen the lever setscrew ❶ and move the lever upwards or downwards until the required length is secured.

(Caution) If the stitch length has been changed, check "(7) Adjustment of rear needle guide" and make a proper readjustment.

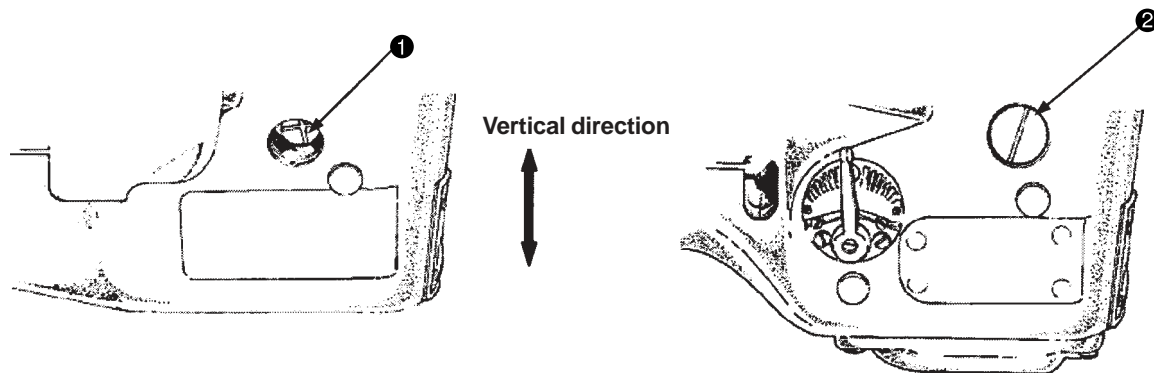

2) Adjustment of differential feed amount

The amount of differential feed can be adjusted by moving the differential adjusting lever ❸ forward or backward.

The graduation plate ❹ is provided with the engraved numbers of 1 to 9. Numbers 1 to 4 denote differential motion, Number 5 denotes no differential motion, and 6 to 9 denote forward differential.

(Caution) No differential function is provided to the single feed mechanism.

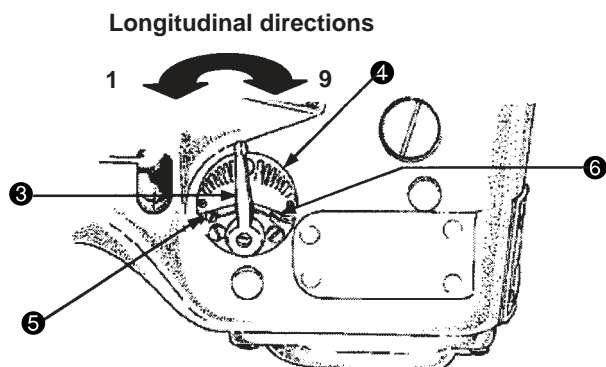

Adjustment Procedures	Results of Improper Adjustment
<p>1) Stitch length adjustment</p> <ol style="list-style-type: none"> 1. When the stitch length adjusting window screw ② is removed, the lever setscrew ① can be seen. <ul style="list-style-type: none"> o Loosen the lever setscrew ① to move the lever upwards and fasten the lever setscrew ① there. This action increases the stitch length. o Loosen the lever setscrew ① to move the lever downwards and fasten the lever setscrew ① there. This action decreases the stitch length. <p>(Caution) No graduation is available for the adjustment of the stitch length.</p> <p>2) Adjustment of differential feed amount</p> <ul style="list-style-type: none"> o When the differential adjusting lever ③ is advanced in the reverse differential direction (1 to 4), the differential ratio is decreased and the sewed materials are extended. o When the differential adjusting lever ③ is retreated in the forward differential direction (6 to 9), the differential ratio is increased and the sewed materials are shrunk. <p>* When fixing the differential adjusting lever ③, pinch it with two setscrews ⑤ and ⑥.</p>	<p>When the stitch length is changed</p> <ul style="list-style-type: none"> o If the forward or backward movement of the main feed dog is changed, the contact amount is also changed between each needle and the rear needle holder. Since this can be a cause of stitch skipping, the rear needle holder should be readjusted.

(11) Presser adjustment

Standard Adjustment

1) Adjustment of amount of rise of presser

The standard amount of rise is 6.5mm for the standard class of the presser ❶. (Maximum amount of rise: 9 mm)

In standard positioning, the presser ❶ begins to rise faster by 3.2mm above the upper face of the throat plate ❷ before the upper feed roller begins to rise.

(Caution) 35800BWW-DWW: The maximum amount of rise is 10mm for extra-heavy materials.

2) Adjustment of presser bar pressure

Proper pressure of the presser ❶ shall be applied to the material while it is sewn.

Turn the pressure adjusting nut ❿ clockwise and counterclockwise to adjust pressure.

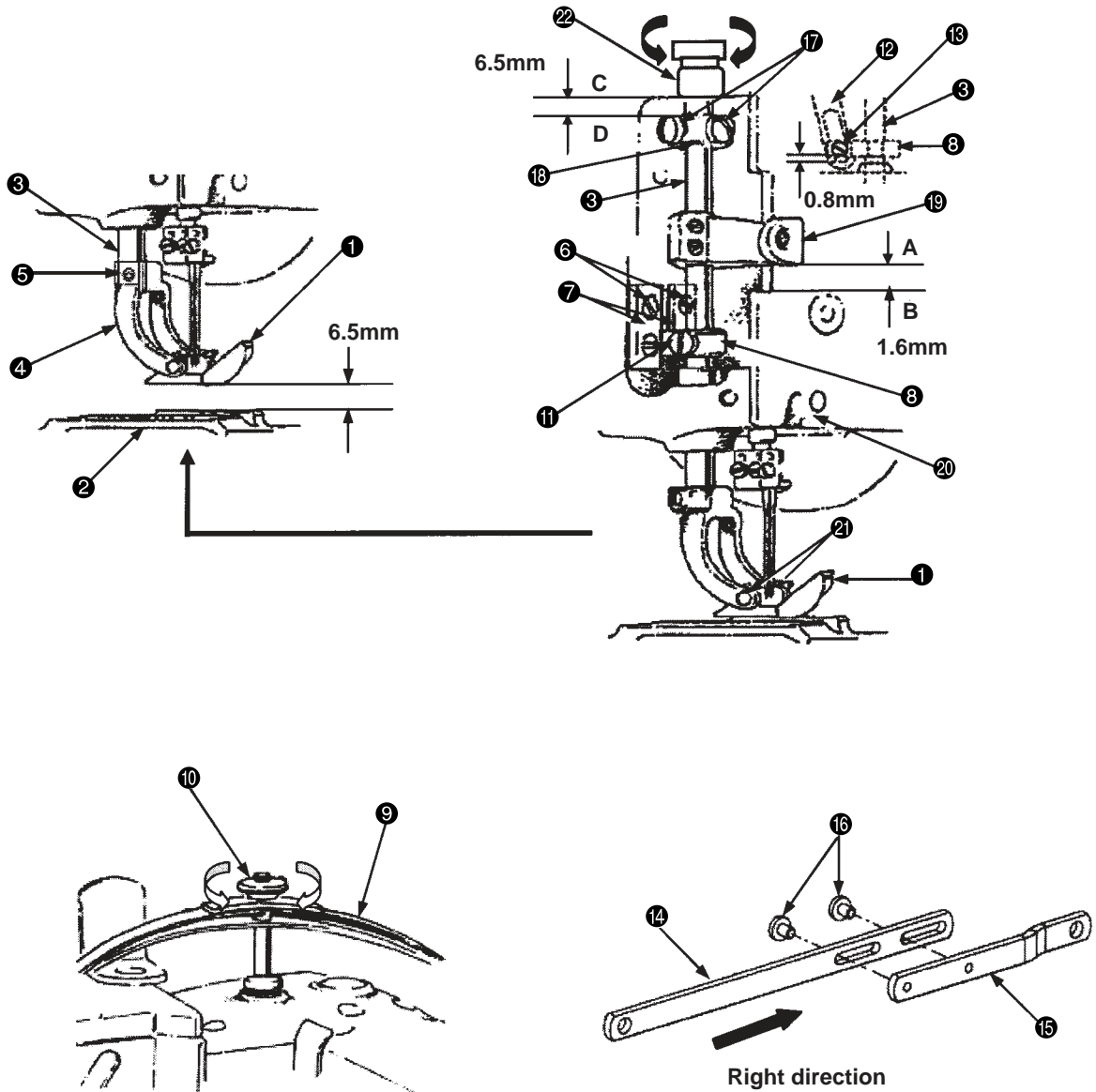

Adjustment Procedures	Results of Improper Adjustment
<p>1. Installation and pressure adjustment of presser and presser yoke</p> <p>(1) Raise the presser shaft ③, mount the presser yoke ④ on the presser shaft ③, and tighten the setscrew ⑤.</p> <p>(2) Confirm whether the presser shaft ③ smoothly moves up and down, being free from rattling on the right and left. If there is rattling on the right and left, loosen four setscrews ⑥ to set up the presser shaft guide ⑧ to eliminate right and left rattling by means of the right/left holding guide plate ⑦. Make adjustments to permit the presser shaft to perform light movement up and down. Since then, tighten the setscrew ⑥.</p> <p>(3) Install the pressure adjusting leaf spring set ⑨ and turn the pressure adjusting nut ⑩ until pressure of the presser ① is duly adjusted.</p> <ul style="list-style-type: none"> o Turning the pressure adjusting nut ⑩ clockwise causes the pressure to increase. o Turning the pressure adjusting nut ⑩ counterclockwise causes the pressure to decrease. <p>(4) In order to make the presser ① rise by 3.2mm faster than the upper feed roller, loosen the setscrew ⑪ of the presser shaft guide ⑧ and move the presser shaft guide ⑧ up and down until a clearance of 0.8mm is secured between the lower hole face of the lever link ⑫ and the bottom face of the lever link hanger setscrew ⑬. (Lower dead point of the needle bar)</p> <p>(Caution) When the above-mentioned adjustments are made, the connecting positions shall be secured for the lifter lever ⑭ with slide hole and the lifter lever ⑮ by moving the lifter lever ⑭ with slide hole in the right direction. When proper positioning has been secured, tighten the setscrew ⑯.</p> <p>(5) To secure the standard amount of rise of 6.5mm for the presser ①, loosen the setscrew ⑰ and move the stop collar ⑱ up and down until a clearance of 6.5mm is secured between the lower face "C" of the mounting position of the presser shaft guide bush ⑲ and the upper face "D" of the stop collar ⑱. Since then, tighten the setscrew ⑰.</p> <p>(Caution) At the same time, check the mounting position of the needle thread rocking thread take-up bar connecting base ⑲. At the lower dead point of the needle bar, a clearance of 1.6mm shall be secured between the bottom face A of the needle thread rocking thread take-up bar connecting base ⑲ and the upper face B of the cut section of the front cover ⑳.</p> <p>2. Removal and installation of presser only</p> <p>(1) To replace presser ① only, loosen the right and left setscrews ⑳ and change the presser ①. Then, tighten the right and left setscrews ㉑.</p>	<ul style="list-style-type: none"> o If the amount of presser rise is too excessive than required, the presser will touch the needle clamp, thus causing needle breakage or stitch skipping. o If pressure of the presser is too insufficient or excessive than required, the material cloth will advance awkwardly.

(12) Adjustment of upper feed roller

Standard Adjustment

1. Adjustment of upper feed roller

- (1) The standard clearance is 0.08mm minimum to 0.13mm maximum between the lower position of the upper feed roller ① and the upper face of the throat plate ②.
- (2) The standard front/rear and right/left clearances shall be uniform between the upper feed roller ① and the feed dog ③.
- (3) The standard positioning of the upper feed roller ① shall be free from right and left rattling, permitting smooth movement up and down.

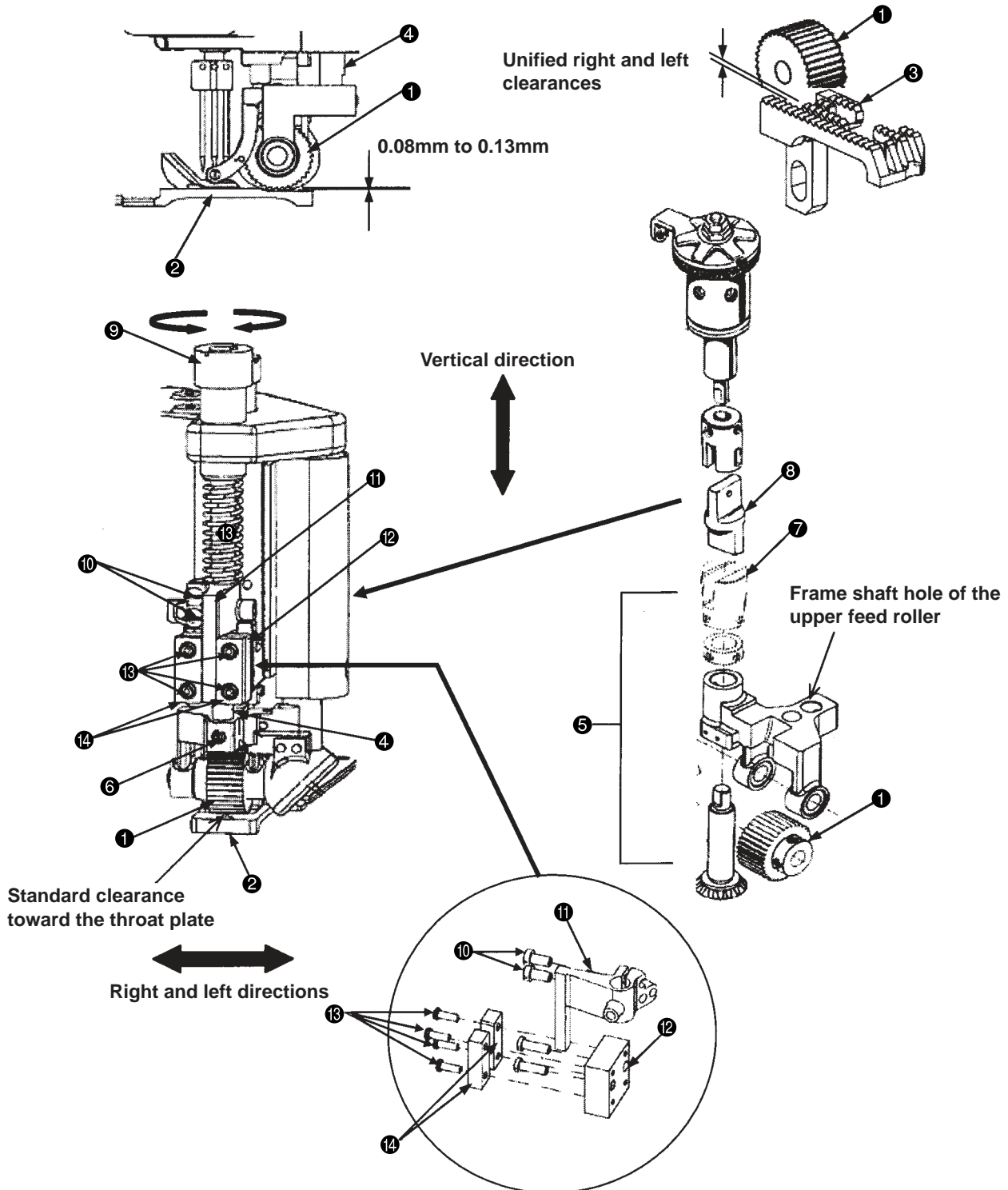

Adjustment Procedures	Results of Improper Adjustment
<p>1. Installation of upper feed roller</p> <p>(1) Raise the upper feed roller pressing shaft ④ and insert the upper feed roller pressing shaft ④ in the frame shaft hole of the upper feed roller frame set ⑤. Then, tighten the setscrew ⑥. Simultaneously at that time, insert the lever connecting section ⑦ in between the roller connecting section ⑦ to join it.</p> <p>(2) Install the roller pressure adjusting screw ⑨.</p> <p>(3) Confirm that a standard clearance (Clearance gauge: 0.08mm to 0.13mm) is secured between the upper feed roller ① and the upper face of the throat plate ②.</p> <p>(4) Confirm that there is proper pressure at the upper feed roller ①, enough to feed the material cloth.</p> <p>☆ Pressure adjustment</p> <ul style="list-style-type: none"> ○ Turning the roller pressure adjusting screw ⑨ clockwise causes the pressure to increase. ○ Turning the roller pressure adjusting screw ⑨ counterclockwise causes the pressure to decrease. <p>(Caution) Confirm that the upper feed roller pressing shaft ④ can be raised by both hands when installing the roller pressure adjusting screw ⑨.</p> <p>2. Clearance adjustment between upper feed roller and throat plate</p> <p>(1) If the standard clearance adjustment seems to be improper, loosen two setscrews ⑩ and raise the upper feed roller pressing shaft ④. Insert the clearance gauge in between the upper face of the throat plate ② and the lower position of the upper feed roller ①. Then, lower the upper feed roller pressing shaft ④.</p> <p>(2) Tighten two setscrews ⑩ under the condition that the bottom face of the guide finger ⑪ is put on to keep contact with the upper face of the guide support block ⑫.</p> <p>(3) In the state as seen from behind, confirm that the vertical clearance of the upper feed roller ① is maintained at the standard level in conjunction with the throat plate ②</p> <p>(4) In the state as seen from behind, confirm that the front and rear right/left clearances on the right side of the upper feed roller ① are uniformly maintained in conjunction with the feed dog ③.</p> <p>(Caution) The right/left clearance between the upper feed roller ① and the feed dog ③ shall be confirmed while the feed dog ③ is positioned at the highest level.</p> <p>3. Adjustment of parallelism between upper feed roller and feed dog</p> <p>(1) Loosen the setscrew ① and turn the upper feed roller pressing shaft ④ to the right and left to confirm that uniform clearances are retained in front / rear and right / left positions between the upper feed roller ① and the feed dog ③. Since then, tighten the setscrew ⑩.</p> <p>4. Adjustment to eliminate right and left rattling in the upper feed roller</p> <p>(1) If there is right and left rattling in the upper feed roller ①, loosen the setscrew ⑬ and hold the guide finger ⑪ to eliminate right and left rattling, using the right/left guide plate ⑭. Since then, tighten the setscrew ⑬.</p>	<ul style="list-style-type: none"> ○ If the upper feed roller ① touches the throat plate ② and there is too much pressure, this will be a cause of cutting off the . ○ If the clearance is too much between the upper feed roller ① and the throat plate ②, this will be a cause of failure in supplying the ○ If pressure of the upper feed roller ① is too weak for the material cloth, uneven feeding may arise.

(13) Replacement and adjustment of upper feed roller

Standard Adjustment

1. Replacement of upper feed roller

Each version is provided with the standard upper feed roller ❶.

The replacing parts for the upper feed roller ❶ come in six types. According to the sewing materials, use these parts replacing the upper feed roller ❶.

(Caution) In the case of replacement of the roller from narrow width to wide width, and vice versa, both the throat plate and the feed dog should also be replaced.

Upper feed roller name and US part No., JUKI part No.

No.	Name	US Part No.	JUKI Part No.
1	Standard type narrow roller	35875AV	30539100
2	Inverted type narrow roller	35875AW	30555106
3	Narrow rubber roller	35826EF	30327100
4	Standard type wide roller	35826X	30515704
5	Inverted type wide roller	35826CB	30553804
6	Wide rubber roller	35826DZ	40059568

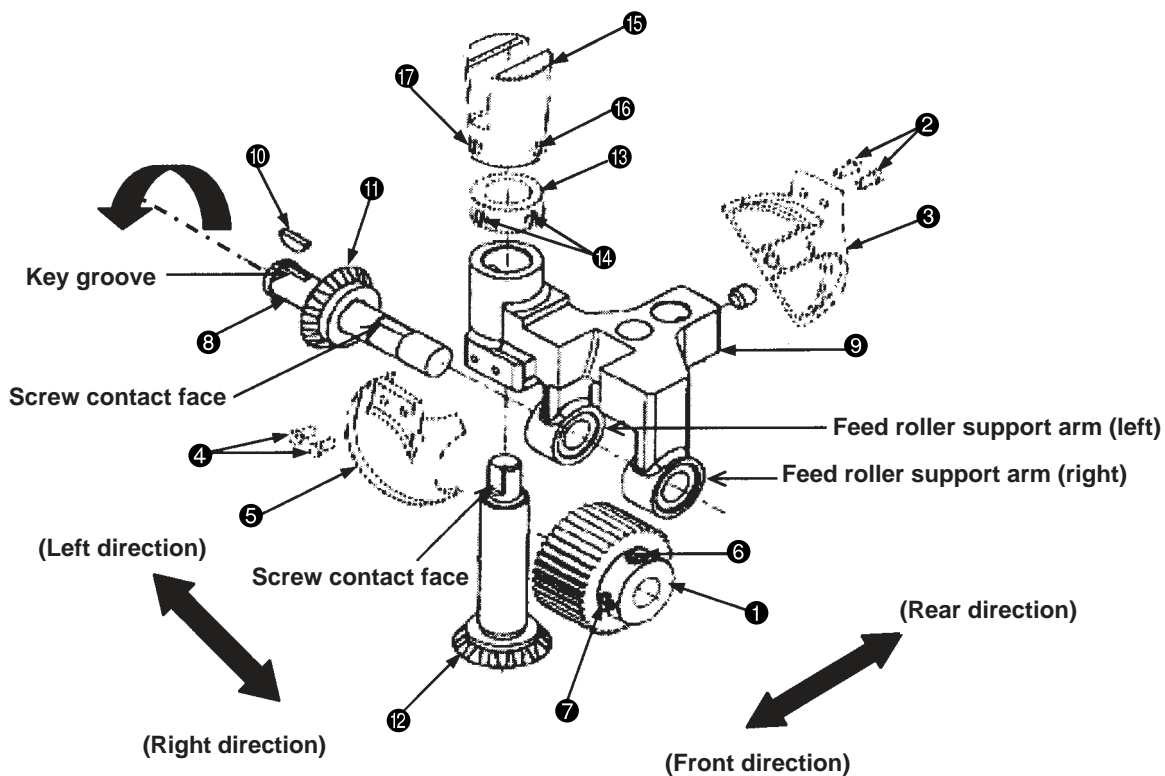

Adjustment Procedures	Results of Improper Adjustment
<p>1. Replacement of upper feed roller</p> <p>(1) Loosen the setscrews ② and remove the front gear cover ③.</p> <p>(2) Loosen the setscrews ④ and remove the rear gear cover ⑤.</p> <p>(3) Loosen two setscrews (⑥ and ⑦) and pull out the roller shaft ⑧ from the upper feed roller frame ⑨ in the left direction. Then, the upper feed roller can be dislodged.</p> <p>(Caution) Pull it out with the key ⑩ groove of the roller shaft ⑧ positioned just above. When the key ⑩ groove is positioned just under, the key ⑩ falls down.</p> <p>(4) Insert the replacing upper feed roller ① in between the right and left feed roller support arms of the upper feed roller frame ⑨. Then, insert the roller shaft ⑧ in the right direction from the left direction of the feed roller support arm (left).</p> <p>(Caution) Adjust the key ⑩ position, attached with the roller shaft ⑧, to the key ⑩ groove hole of the horizontal drive gear ⑪, and insert it.</p> <p>(5) Apply the right side of the horizontal drive gear ⑪ to the left side of the feed roller support arm (left). Then, apply the left side of the upper feed roller ① to the right side of the feed roller support arm (left). Tighten the setscrew ⑥ after confirming that there is no rattling on the right and left and light revolution seems to be secured. Tighten the remaining setscrew ⑦.</p> <p>(Caution) The upper feed roller ① screws (⑥ and ⑦) are positioned on the right as seen from the front. In regard to the screw contact face of the roller shaft ⑧, the screw ⑥ keeps a rear contact in conjunction with the revolving direction.</p> <p>(6) Mount the rear gear cover ⑤, and tighten the setscrews ④.</p> <p>(7) Mount the front gear cover ③, and tighten the setscrews ②.</p> <p>2. Installation of vertical drive gear</p> <p>(1) Insert the vertical drive gear ⑫ in the mounting hole of the upper feed roller frame ⑨. Then, install the collar ⑬ and tighten the setscrew ⑭ so that the vertical drive gear ⑫ is free from vertical rattling.</p> <p>(2) Mount the roller connector ⑮ on the shaft section of the vertical drive gear ⑫ and adjust it to the contact face of the shaft section. Tighten the setscrew ⑯ and also the remaining setscrew ⑰.</p> <p>(Caution) When replacing the vertical drive gear ⑫, remove the horizontal drive gear ⑪ in the first place.</p>	<p>o The upper feed roller ① should be selected according to the type of material cloth. Otherwise, the material cloth may get roller-borne flaws.</p>

(14) Adjustment of drawing amount of upper feed roller

Standard Adjustment

1. Drawing amount of upper feed roller

The standard amount of draw for the upper feed roller ① is defined to cause a slight pulling force for the sewing length (8 stitches/inch) of the feed dog.

The clutch connecting lever ② and the clutch set ③ are connected. The amount of draw for the material cloth can be changed by moving the clutch connecting rod ④ vertically.

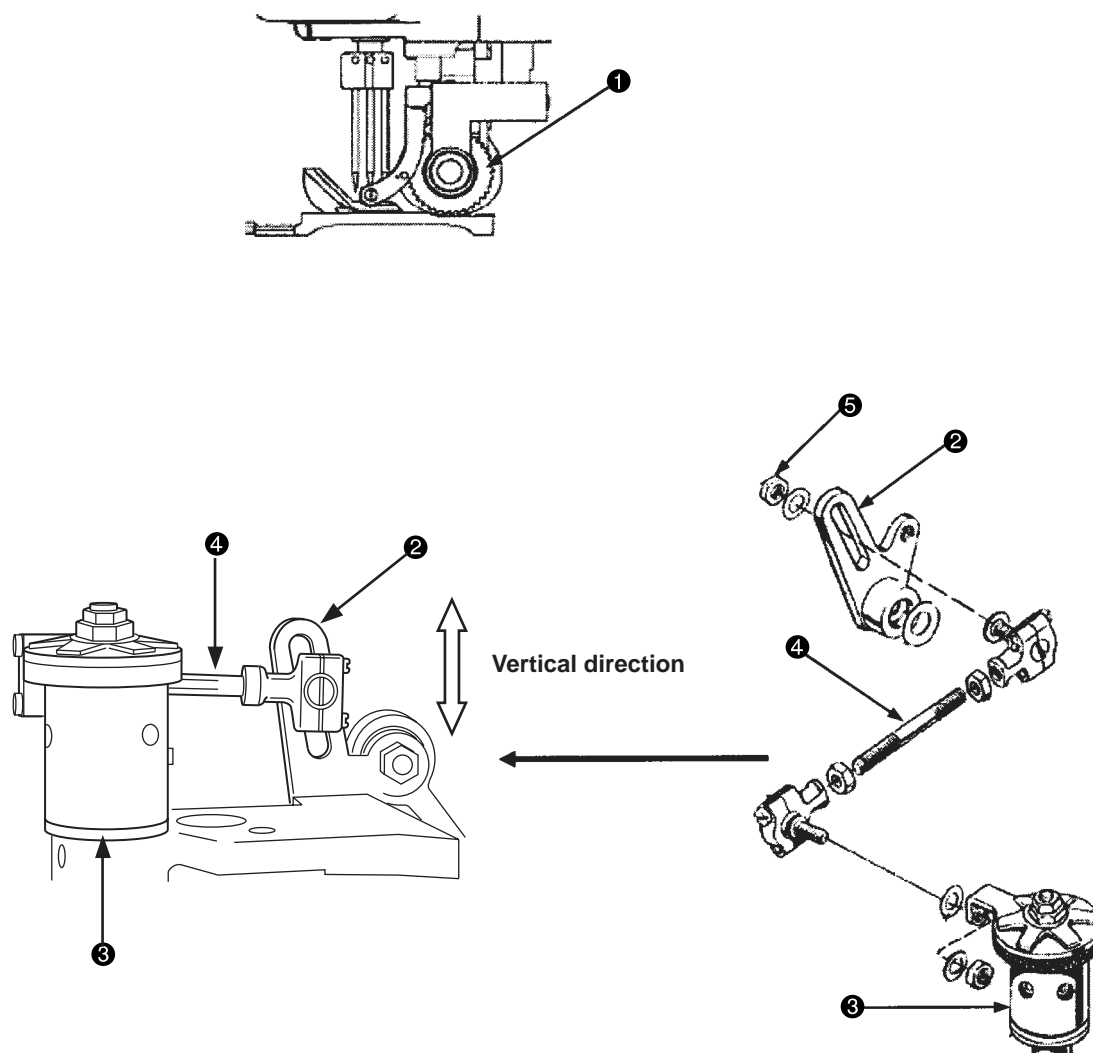

Adjustment Procedures	Results of Improper Adjustment
<p>1. Adjustment of drawing amount of upper feed roller</p> <p>(1) Loosen the nut ⑤ (spanner: 3/8), tighten the nut ⑤ after adjusting the clutch connecting rod ④ vertically.</p> <ul style="list-style-type: none"> o When the clutch connecting rod ④ is raised, the amount of draw for the material cloth is increased. o When the clutch connecting rod ④ is lowered, the amount of draw for the material cloth is decreased. 	<ul style="list-style-type: none"> o If the amount of draw for the upper feed roller ① is too much in conjunction with the sewing feed amount, the number of stitches is increased. o If the amount of draw for the upper feed roller ① is too less, sewing problem occurs and this is a cause of feed error. In particular, this problem occurs around the hinged section.

(15) Adjustment of needle thread path

Standard Adjustment

Adjustment of needle thread path

The needle thread adjusting thread path ① is installed just under the needle thread guide ③ so that there is no sag of the needle thread that passes through the lever thread path ② from the needle thread adjusting thread path ① when the needle bar is positioned at the upper dead point.

1) Height of needle thread adjusting path

The standard dimension is 27mm from the hole bottom "A" of the needle thread guide ③ to the hole bottom "B" of the needle thread adjusting thread path ①.

When tightening the needle thread in particular, the dimension shall be 36mm from the hole bottom "C" of the needle thread guide ③ to the hole bottom "D" of the needle thread adjusting thread path ①.

2) Height of rocking take-up path

The standard dimension is 15mm from the hole bottom "E" of the rocking thread take-up lever thread path ④ to the center "F" of the setscrew ⑦.

3) Height of needle thread guide adjuster

When the needle bar stays at the lower dead point, the standard dimension is 1.6mm from the upper end "G" of the lever thread path ② to the upper end "H" of the needle thread holding adjuster ⑤.

Standard dimension

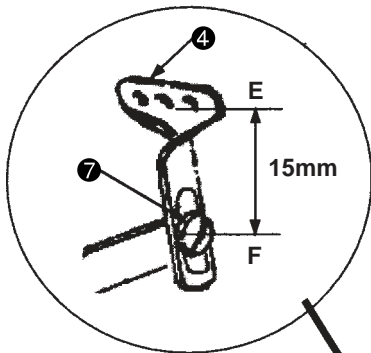

Standard dimension

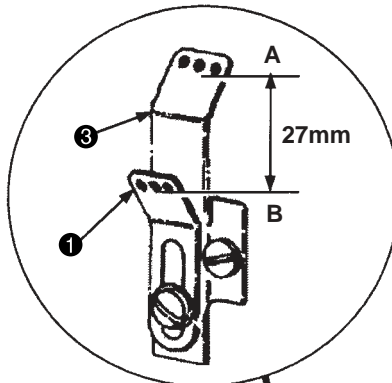

Standard dimension for tightening the needle thread

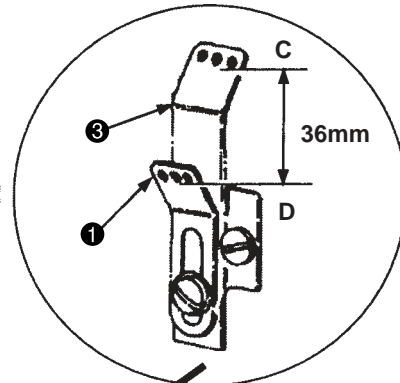

Needle bar at the upper dead point

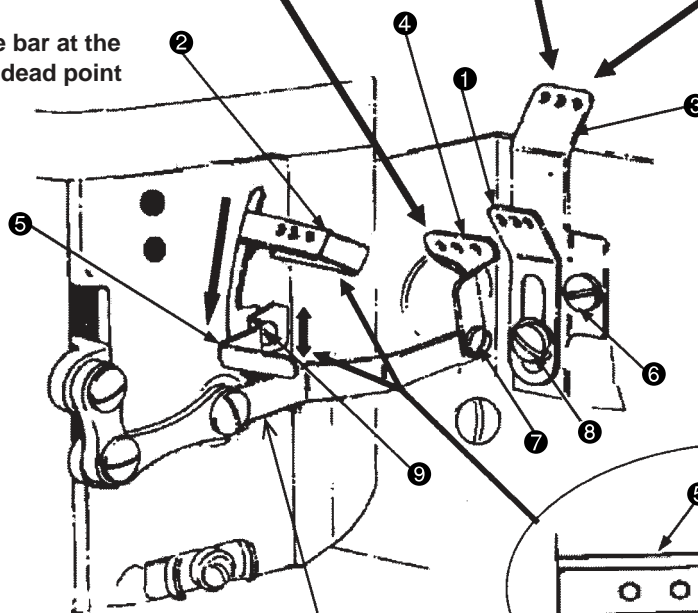

Needle bar at the lower dead point

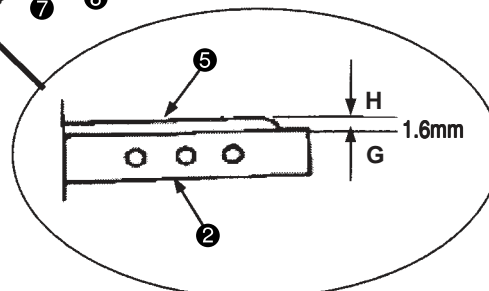

Rocking thread take-up lever

Adjustment Procedures	Results of Improper Adjustment
<p>1. Mounting position of needle thread adjusting path</p> <p>(1) Mount the needle thread path guide ③, and tighten the setscrew ⑥.</p> <p>(2) Mount the needle thread adjusting path ① in the needle thread path guide ③. Measure the standard dimension (27mm) and tighten the setscrew ⑧.</p> <ul style="list-style-type: none"> o Raising the needle thread adjusting path ① causes the needle thread to be loosened. o Lowering the needle thread adjusting path ① causes the needle thread to be tightened. <p>2. Mounting position for the rocking thread take-up lever thread path</p> <p>(1) When the needle bar is positioned at the upper dead point, vertically hold the rocking thread take-up lever thread path ④ and measure the standard dimension (15mm). Tighten the setscrew ⑦.</p> <p>3. Mounting position of needle thread guide adjuster</p> <p>(1) Let the lever thread path ② stay at the lower dead point.</p> <p>(2) Loosen two setscrews ⑨ of the needle thread holding adjuster ⑤ and move the needle thread holding adjuster ⑤ vertically. Measure the standard dimension (1.5mm) and fasten two setscrews ⑨.</p> <ul style="list-style-type: none"> o Lowering the needle thread holder adjusting pin ⑤ causes the needle thread loop to be enlarged. o Lowering the needle thread holder adjusting pin ⑤ causes the needle thread loop to be diminished. <p>(Caution) When the two setscrews ⑨ are loosened and the needle thread holding adjuster ⑤ is moved vertically, it is possible to change the height of "G" and that of "H."</p>	<ul style="list-style-type: none"> o If there is no coincidence between position of each thread path ①/④ and that of the needle thread holding adjuster ⑤, this can be a cause of problems such as stitch skipping, thread breakage, and worse tightening of the needle thread.

(16) Adjustment of bobbin thread cam

Standard Adjustment

1. Adjustment of bobbin thread cam

The standard positioning is secured when the pulley ① is turned counterclockwise and the first setscrew ③ of the bobbin thread cam ② and another first setscrew ④ of the pulley ① are aligned to the same line.

(Caution) When two main shaft setscrews ④ and ⑤ of the pulley ① are turned counterclockwise, the first screw functions as the main shaft contact setscrew ④.

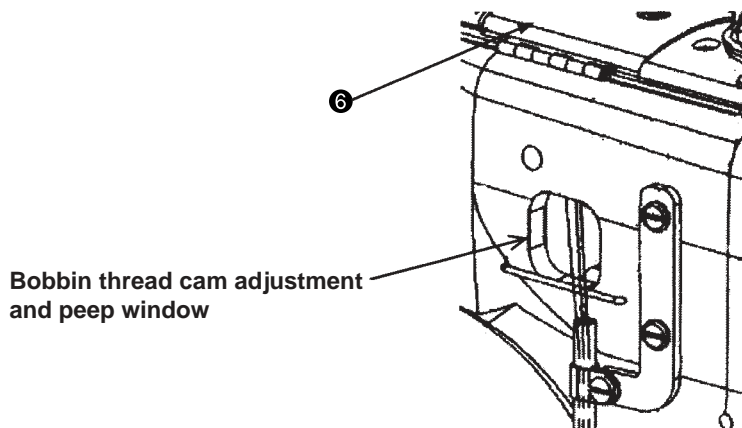
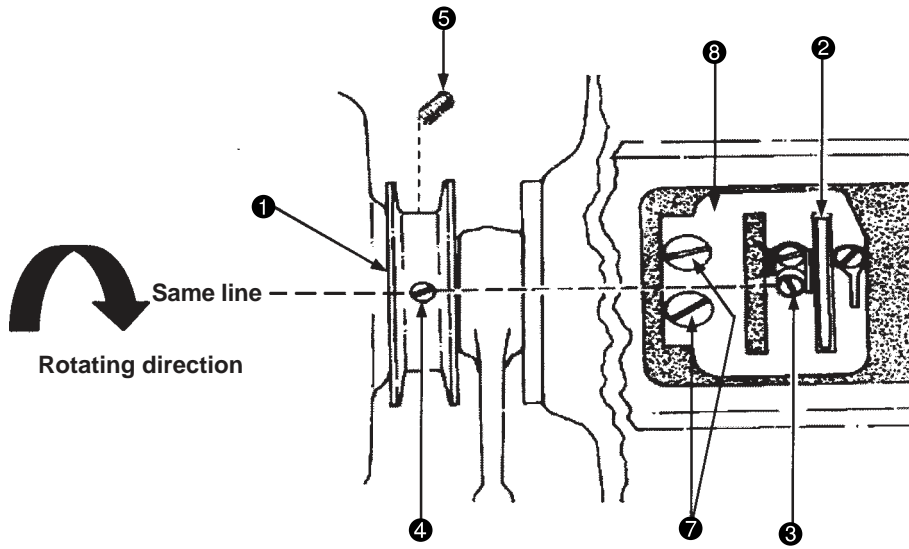

Adjustment Procedures	Results of Improper Adjustment
<p>1. Adjustment of bobbin thread cam</p> <p>1) Open the center top cover ⑥, loosen the setscrew ⑦, and remove the cam thread path base ⑧.</p> <p>2) Turn the pulley ① counterclockwise and confirm whether the first bobbin thread cam setscrew ③ stays on the same line with the first setscrew ④ of the pulley ①.</p> <p>If the bobbin thread cam setscrew ③ seems to be displaced, loosen two setscrews ④ and ⑤ and turn the bobbin thread cam ② forward and backward for adjustment. Then, tighten the setscrew ④.</p> <p>Subsequently, tighten another setscrew ⑤.</p> <p>(Caution) At the time of bobbin thread cam ② adjustments, do not move the bobbin thread cam ② to the right and left. If it is moved to the right and left, the bobbin thread cam ② may come in contact with the right/left side face of the cam thread path base ⑧ groove.</p> <p>3) Install the cam thread path base ⑧ so that it does not touch the right and left faces of the bobbin thread cam ②. Then, tighten the setscrew ⑦.</p> <p>(Caution) The bobbin thread cam ② can be adjusted through the peep window. However, since the inside is dark, a proper light (pen light or the like) should be used during adjustments.</p>	<p>o If the standard position is not secured for the bobbin thread cam ②, this can be a cause of stitch skipping.</p>

(17) Adjustment of tension disk rise

Standard Adjustment

1. Adjustment of tension disk rise

The standard positioning is such that tip of the disc floating pin ③ comes in contact with the upper tension disc ④ when the upper feed roller ① rises by 1.0mm above the upper face of the throat plate ② and that the upper tension disc ④ keeps floating when the upper feed roller ① rises further.

The standard size is 6.5mm between the tip of the disk rise pin ③ and the upper face of the tension thread path ⑤.

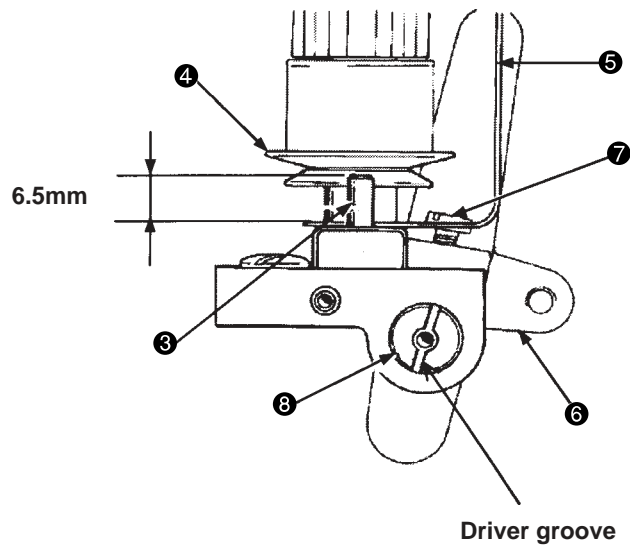
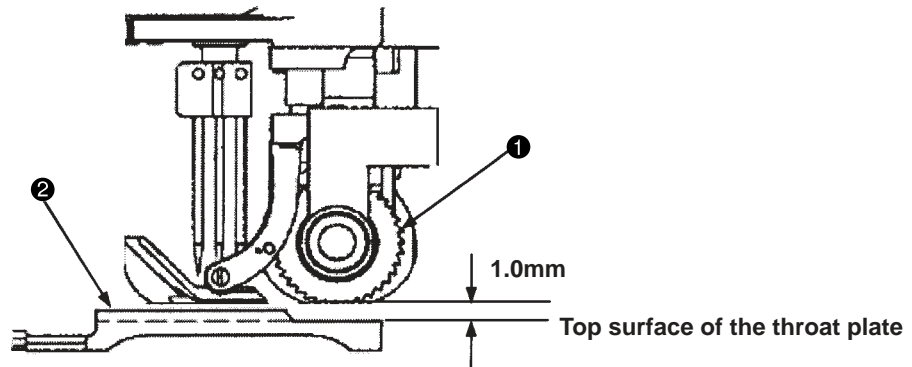

Adjustment Procedures	Results of Improper Adjustment
<p>1. Adjustment of tension disk rise</p> <p>(1) Insert a screwdriver in the driver groove of the tension floating shaft ⑧ and loosen the setscrew ⑦ of the lift lever ⑥. Then, turn the tension floating shaft ⑧ clockwise.</p> <p>(2) Adjust height of the disc floating pin ⑤ to 6.5mm and tighten the setscrew ⑦.</p>	<p>o If proper positioning is not secured for the disc floating pin ⑤, the needle thread and/or the looper thread cannot be pulled out when this action is needed.</p>

(18) Adjustment of air nozzle (air blow)

Standard Adjustment

1. Adjustment of air nozzle (air blow)

The standard position of the nozzle ① is such that it is in parallel to the throat plate ②. Standard forward and backward positioning is that there is no contact when the presser ③ is raised.

Height of the nozzle ① is about 23mm from the throat plate ② in parallel state.

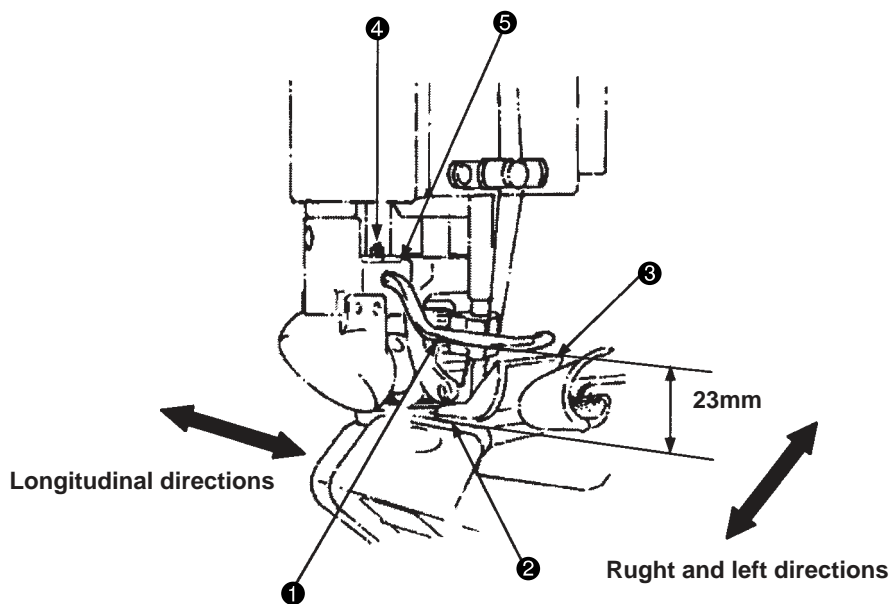

Adjustment Procedures	Results of Improper Adjustment
<p>1. Adjustment of air nozzle</p> <p>(1) The air nozzle ❶ is inserted in the hole of the feed roller frame ❺.</p> <p>(2) To adjust the right and left parallelism for the air nozzle ❶ and the throat plate ❷, loosen the setscrew ❹ and turn the air nozzle ❶ to the right and left for adjustment.</p> <p>(3) To adjust the front and rear positioning for the air nozzle ❶, loosen the setscrew ❹ and move the air nozzle ❶ forward and backward for adjustment.</p>	<p>o This is the air nozzle ❶ to cool down the needle heat. When needle heat is high, this will cause failure in thread breakage and stitch skipping.</p>

(19) Adjustment of folder

Standard Adjustment

1. Folder mounting position

Insert the slide base ③ of the folder set ② in the center of the slide plate ① of the right and left cylinder arms, and slide the presser ④ in forward direction. At that time, a standard clearance of 0.8mm to 1.6mm should be secured between the front section "A" of the presser ④ and the outlet section "B" of the upper folder ⑤.

(Caution) If Section "B" of the upper folder ⑤ is installed as closer as possible to Section "A" of the presser ④, the result of sewing tends to be more stabilized for the material to be sewn. In such a case, however, it is necessary to make sure not to let the upper folder ⑤ come in contact with the presser ④ in the middle of sewing.

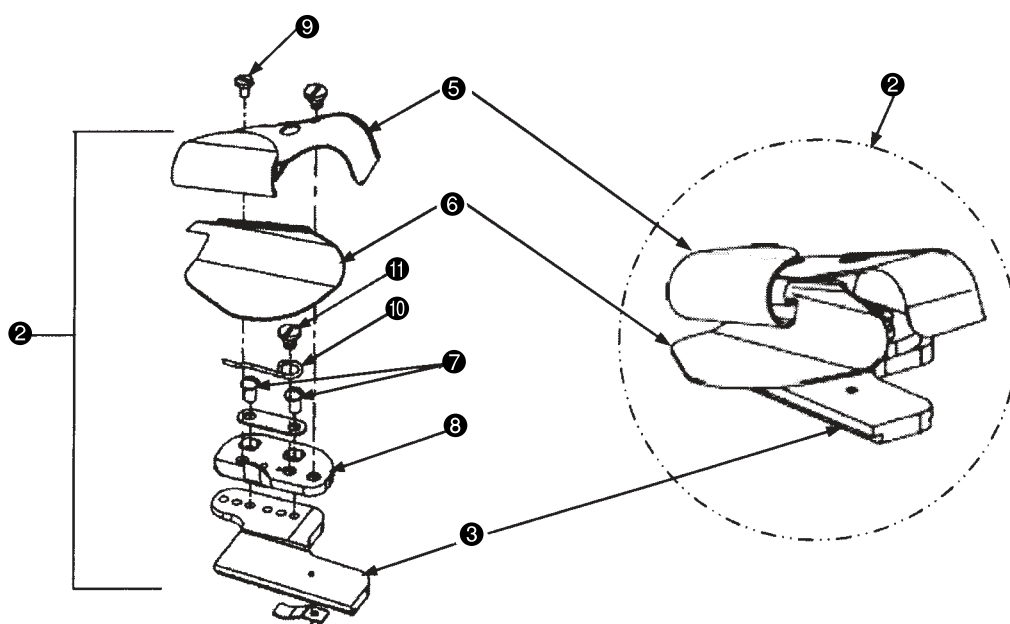
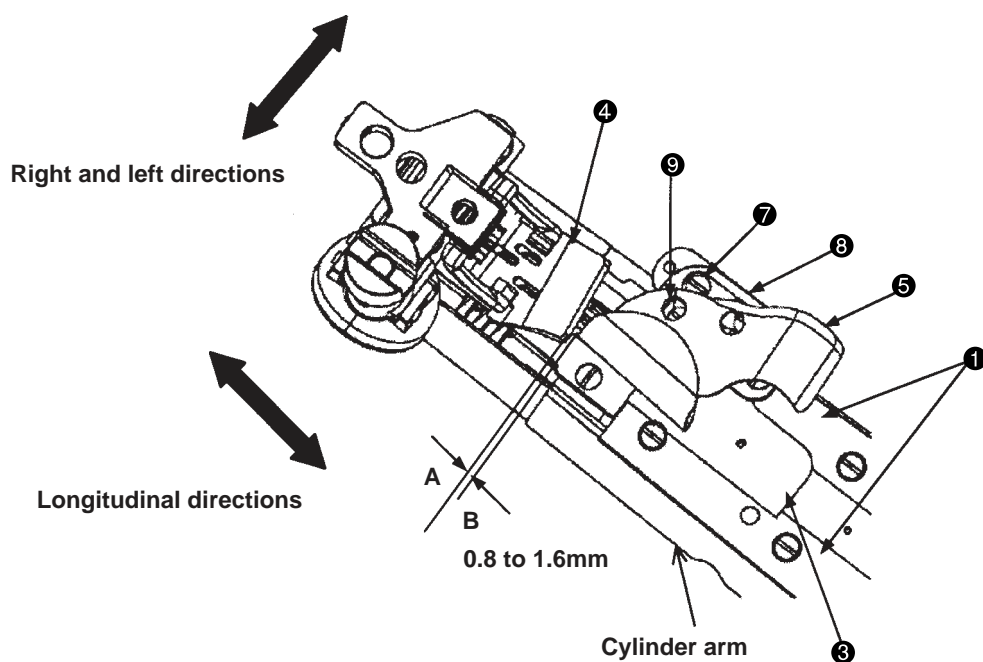

Adjustment Procedures	Results of Improper Adjustment
<p>1. Adjustment of folder mounting position</p> <p>(1) When the folder set ② is installed, confirm whether a standard clearance is secured between the front section "A" of the presser ④ and the outlet section "B" of the upper folder ⑤.</p> <p>If the conditions seem to be awkward in regard to the front and rear contact between the front section "A" of the presser ④ and the outlet section "B" of the upper folder ⑤ and right and left positioning of the upper and lower folders (⑤ and ⑥), loosen two setscrews ⑦ and adjust front/rear and right/left positioning of the folder base ③.</p> <p>(2) If it is necessary to adjust the outlet at the tips of the upper and lower folders (⑤ and ⑥), loosen two setscrews ⑨ and make adjustments by moving the tip of the upper folder ⑤ to the right and left.</p> <ul style="list-style-type: none"> o To widen the outlets of the upper and lower folders (⑤ and ⑥), move the tip of the upper folder ⑤ to the left. o To narrow the outlets of the upper and lower folders (⑤ and ⑥), move the tip of the upper folder ⑤ to the right. <p>(3) The spring ⑩ is fastened to the right side section of the lower folder ⑥ by means of the setscrew ⑪.</p> <p>The tip section of the lower folder ⑥ is devised to have an escape recess somewhat to the right so that an extra-heavyweight material can be duly handled.</p> <p>(Caution) According to the thickness of a material to be sewn, adjust the upper and lower folders (⑤ and ⑥). In addition to the standard folders, the folder set ② comes in five more types. Refer to "9. Folder types".</p>	<ul style="list-style-type: none"> o If positioning of the folder set ② is inaccurate, the quality of the sewn product will be lowered.

8. Lubrication

1. Oil lubrication and check point

The sewing machine head section is of the rotary pump type auto lubrication system.

Remove the oil circulation check windows (front) ① and (rear) ②, and feed a lubricant as high as the level between the upper and lower engraved marker lines of the oil gauges (front) ③ and (rear) ④.

2. Oil drain spot

To replace the lubricant, remove the oil drain (front) and (rear) screws ⑤ and ⑥. Upon the completion of oil drainage, tighten the oil drain (front) and (rear) screws ⑤ and ⑥.

(Caution) To confirm the amount of oil at the oil gauge (rear) ④, check the crest point of the oil level indicator that is actuated by an oil float. In some cases, the oil level indicator does not come up immediately. Make sure not to commit overfilling of the oil in such a case.

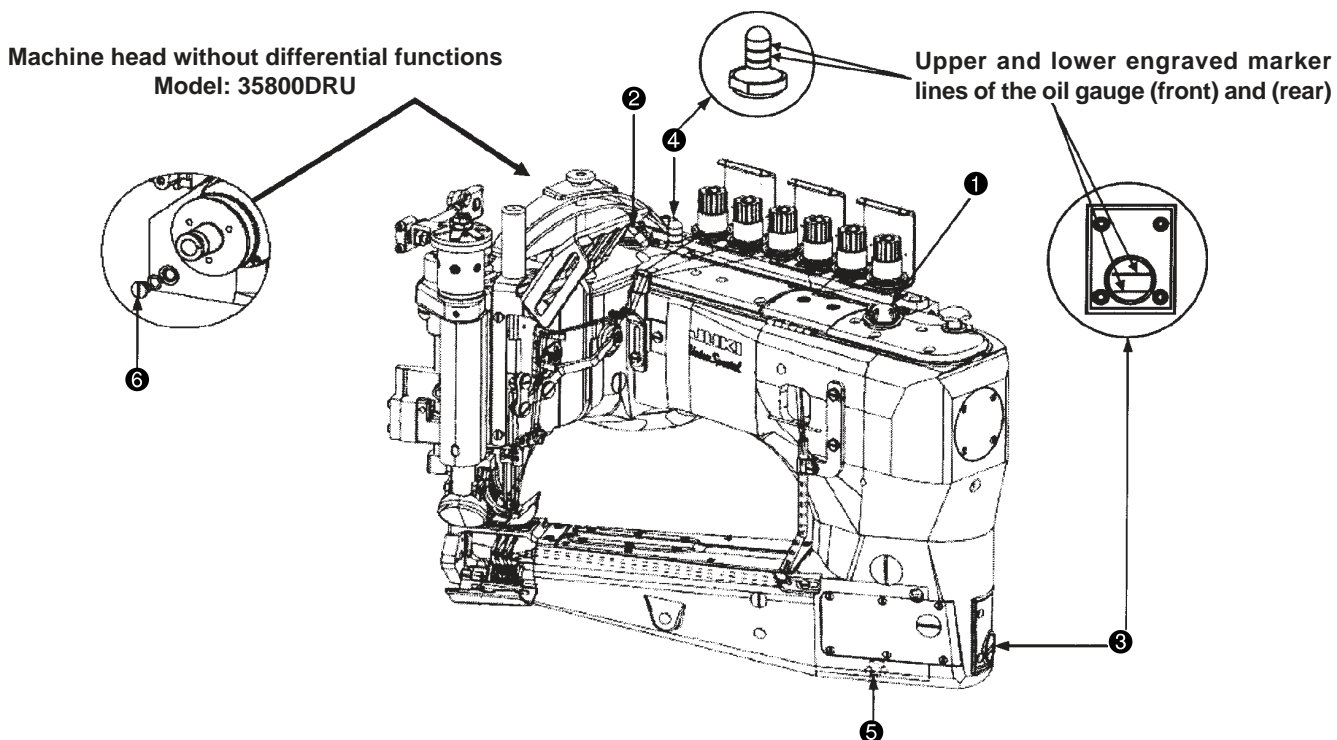
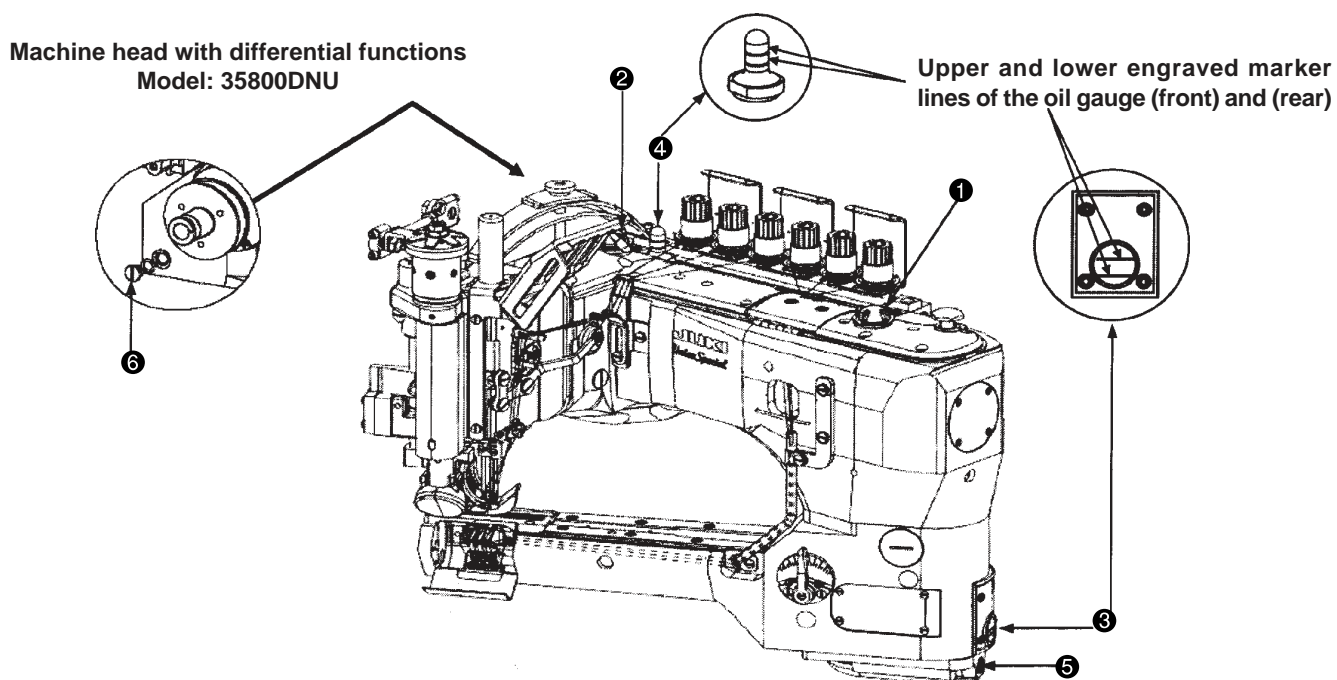

9. Folder types

1. Select an optimal folder according to nature, thinness, and thickness of the material cloth.

(Caution) The – line (minus line) in the JUKI Part Numbers denotes a part for which Part No. setup is not finished at the Parts Center.



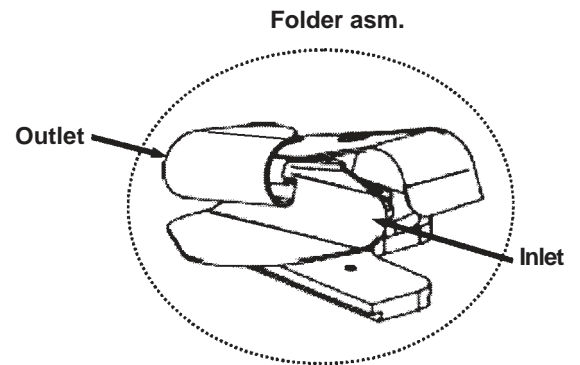

(Acceptable at the time of ordering)



No	JUKI part No.:	Folder asm./Product name	Outlet dimensions	Folder features
1	24502502	23420AY18-1/8	3.2mm	A standard type provided with a spring, suitable for a product that has step sections in the material cloth. (Standard)
2	—————	23420AY18-1/16	1.6mm	Same as the standard type. The outlet section at the folder tip is narrow, and suitable for thin materials.
3	24648503	23420AY18-3/32	2.4mm	Same as the standard type. The outlet section at the folder tip is narrow, and suitable for medium-weight materials.
4	24683302	23420AY18-5/32	4.0mm	Same as the standard type. The outlet section at the folder tip is wide, and suitable for extra-heavyweight materials.
5	24503005	23420Z-9-1/8	3.2mm	The folder tip section is shorter than that of the standard type. Functionally same. A shorter type assures easier control of materials.
6	—————	23420DC9	3.2mm	This is a fixed folder without a spring. Deviation is minimal as a result of too much pressing of the material.

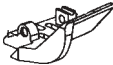
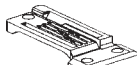
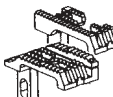

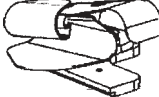

10. Maintenance

(1) Spare parts

No.	Model	Gauge (mm)		Feed method (feed dog)	Roller feed mechanism							
						Presser	Throat plate	Main feed dog	Differential feed dog	Needle clamp	Upper feed roller	Folder
1	35800BLW	9	3.6+3.6	Differential feed	Belt	35820BQW9 [27579507]	35824BQW9 [27691906]	35805DLW [30368401]	35826DLW9 [30368500]	35818CB9 [30541502]	35826X [30515704]	23420AY-18-1/8 [24502502]
0	136. . @OU	8	3.2+3.2	1 piece feed	Belt	35820BQW8 [———]	35824BQW8 [27799006]	136. 3@OU 7 Yl. 147/ 3/[—————	35818CB8 [24743304]	35826X [30515704]	23420AY-18-1/8 [24502502]
		9	3.6+3.6			35820BQW9 [27579507]	35824BQW9 [27691906]		—————	35818CB9 [30541502]		
3	35800BWDN	8	3.2+3.2	Differential feed	Belt	35830DN8 [24553406]	35824DX8 [30376206]	35805EB8 [30536809]	35826ED [30536908]	35818CB8 [24743304]	35826X [30515704]	23420AY-18-1/8 [24502502]
		9	3.6+3.6			35830DN9 [30537203]	35824DX9 [30376305]			35818CB9 [30541502]		
4	35800BWDR	8	3.2+3.2	1 piece feed	Belt	35830BXW8 [30530208]	35824DQW8 [———]	35805BRW8 [30368757]	—————	35818CB8 [24743304]	35826X [30515704]	23420AY-18-1/8 [24502502]
		9	3.6+3.6			35830BXW9 [30516306]	35824DQW9 [30059406]		—————	35818CB9 [30541502]		
5	35800BRWH	9	3.6+3.6	1 piece feed	Belt	35830BXW9 [30516306]	35824DQW9 [30059406]	35805BRWH9 [30526800]	—————	35818CB9 [30541502]	35826X [30515704]	23420AY-18-1/8 [24502502]
6	35800BWW	8	3.2+3.2	Differential feed	Belt	35830DWW8 [30530307]	35824DX8 [30376206]	35805DX [30376305]	35826DX [30384200]	35818CB8 [24743304]	35826X [30515704]	23420AY-18-1/8 [24502502]
		9	3.6+3.6			35830DWW9 [30529606]	35824DX9 [30376305]			35818CB9 [30541502]		
7	35800BLU	9	3.6+3.6	Differential feed	Clutch	35830DL9 [27580208]	35824BQ9 [27580109]	35805DP8 [24531402]	35826DL [27772004]	35818CB9 [30541502]	35875AV [30539100]	23420AY-18-1/8 [24502502]
8	35800DNU	8	3.2+3.2	Differential feed	Clutch	35830DM8 [24600405]	35824DN8 [24556003]	35805DP8 [24531402]	35826DP [24582801]	35818CB8 [24743304]	35875AV [30539100]	23420AY-18-1/8 [24502502]
		9	3.6+3.6			35830DM9 [24578408]	35824DN9 [24552101]			35818CB9 [30541502]		

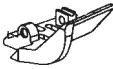
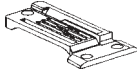
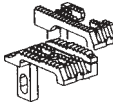
To the next page

To the next page

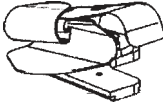
No.	Model	Gauge (mm)		Feed method (feed dog)	Roller feed mechanism							
						Presser	Throat plate	Main feed dog	Differential feed dog	Needle clamp	Upper feed roller	Folder
9	35800DRU	8	3.2+3.2	1 piece feed	Clutch	35830BX8 [24864001]	35824DQ8 [27775204]	35805BR8 [30384101]	—	35818CB8 [24743304]	35875AV [30539100]	23420AY-18-1/8 [24502502]
		9	3.6+3.6			35830BX9 [30326003]	35824DQ9 [—]		—	35818CB9 [30541502]		
10	35800DZ	32	3.2+3.2	Differential feed	Clutch	35830DM8 [24600405]	35824DN8 [24556003]	35805DP8 [24531402]	35826DP [24582801]	35818CB8 [24743304]	35875AV [30539100]	23420AY-18-1/8 [24502502]
		36	3.6+3.6			35830DM9 [24578403]	35824DN9 [24552101]			35818CB9 [30541502]		
11	35800PZ	32	3.2+3.2	1 piece feed	Clutch	35830BX8 [24864001]	35824DQ8 [27775204]	35805BR8 [30384101]	—	35818CB8 [24743304]	35875AW [30555106]	23420AY-18-1/8 [24502502]
		36	3.6+3.6			35830BX9 [30326003]	35824DQ9 [—]		—	35818CB9 [30541502]		
12	35800DWW	8	3.2+3.2	Differential feed	Clutch	35830DWW8 [30530307]	35824DX8 [30376206]	35805DX [30466809]	35826DX [30384200]	35818CB8 [24743304]	35826X [30515704]	23420AY-18-1/8 [24502502]
		9	3.6+3.6			35830DWW9 [30527606]	35824DX9 [30376305]			35818CB9 [30541502]		

(Caution) Number in [] is a Juki Part No. When making an order to the Parts Center, use the Part No. indicated in [].

The - line (minus line) in [] denotes a part for which Part No. setup is not finished at the Parts Center. (Acceptable at the time of ordering)

11. Part numbers and names of the modification parts for the 35800 Class – B8/B9 soft chain stitches (balloon stitches)

Parts No. and Name

When the 35800-class 8/9 gauge standard type is modified into the type of B-8/B-9 soft chain stitches, the following parts shall be replaced.

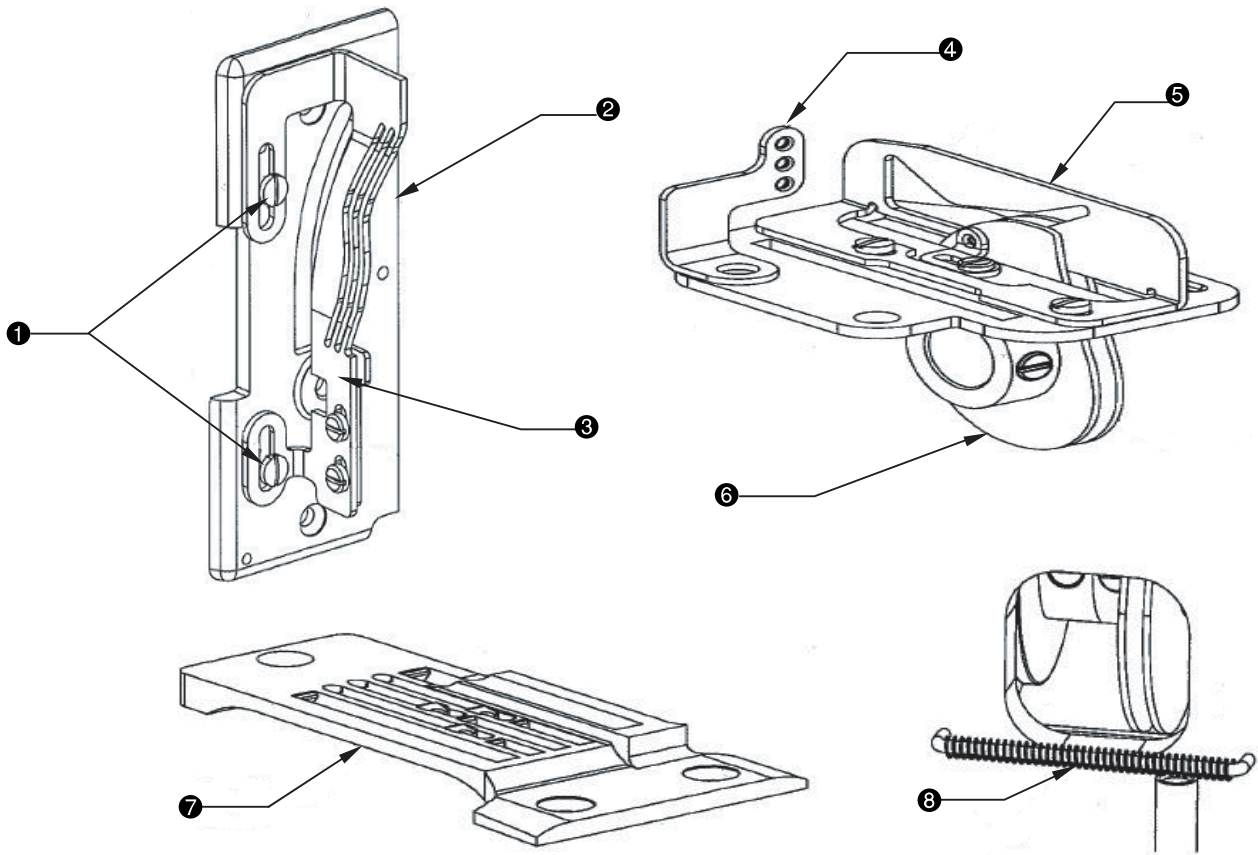

List of Parts for the 35800DNU-B8/B9

No.	Name	35800DNU-B8		35800DNU-B9		Q'ty
		Narrow roller	Wide roller	Narrow roller	Wide roller	
	Set	29480BEB 40057259 (JUKI part No.)	29480BEA 40057260 (JUKI part No.)	29480BDY 40057261 (JUKI part No.)	29480BDZ 40057262 (JUKI part No.)	1
①	Setscrew	22704 30103006 (JUKI part No.)				2
②	Front cover	35882K 30516702 (JUKI part No.)				1
③	Thread path asm. for needle thread control	29476CB 40056218 (JUKI part No.)				1
④	Thread path for bobbin thread guide	50658A US00050658A (JUKI part No.)				1
⑤	Thread path asm. for cast-off plate	29476CA 40056219 (JUKI part No.)				1
⑥	Bobbin thread cam	35823D 40056220 (JUKI part No.)				1
⑦	Throat plate	35824EC8 40057263 (JUKI part No.)	35824DZ8 40057264 (JUKI part No.)	35824EC9 40057265 (JUKI part No.)	35824DZ9 40057266 (JUKI part No.)	1
⑧	Spring	35853AN 40056222 (JUKI part No.)				1

12. Troubles and corrective measures

Trouble	Cause (1)	Cause (2)	Check and corrective measures
1. Thread breakage	1-1) Threading	1-A) Thread jamming at thread guide, threading error	6. Refer to "How to conduct threading".
	1-2) Thread path	2-A) Flaws, burrs, rust generation, and the like can be a cause of resistance in operation if they are present in needles, throat plate, small thread tension, needle thread rocking thread path, needle thread guide thread path, lower looper, bobbin thread guide pipe, bobbin thread cam, lower thread path guide, and thread tension disc.	Take measures to remove flaws, burrs, etc., and finish the thread path neatly. In this case, however, the lower looper, throat plate, bobbin thread cam, and such important parts should be replaced if their shapes seem to have changed.
	1-3) Rear needle guide	3-A) If contact between the needle and rear needle guide is excessive, needle grooves are created on the rear needle guide, resulting in thread cut.	Replace the needle, and replace the part if the rear needle guide is worn.
	1-4) Needle	4-A) The needle is too thin for the thread that is now used.	Use an appropriate needle.
	1-5) Needle heat	5-A) Thread cut occurs because of heated needle depending on the material type, the number of superimposed materials, and sewing speed.	Reduce the needle size. Reduce the sewing speed. Use needle cooling air.
	1-6) Thread	6-A) Poor quality of the thread	Use a high-quality thread.
	1-7) Thread tension	7-A) Excessive thread tension	Reduce the thread tension. Thread tension is excessive because the needle thread adjusting thread path has been lowered too much.
	1-8) Contact	8-A) The lower looper touches the feed dog or throat plate because of an improper lower looper position. The looper touches the rear needle guide because of insufficient looper return.	Set the lower looper in the proper position.
	1-9) Idle loop error	9-A) Coordination is awkward between needle and looper timing. Position of the bobbin thread cam is inadequate. Clearance is too much between the upper feed roller and the upper face of the throat plate.	Set the lower looper in the proper position.

Trouble	Cause (1)	Cause (2)	Check and corrective measures
2. Thread cut at bobbin thread looper	2-1) Thread path	1-A) Resistance is developed when there is a scratch, a burr, or rust on the throat plate, lower looper, bobbin thread cam, bobbin thread path pipe, bobbin thread path guide, or thread tension disc.	Take measures to remove flaws, burrs, etc., and finish the thread path neatly. In this case, however, the throat plate, lower looper, bobbin thread cam, and such important parts should be replaced if their shapes seem to have changed.
	2-2) Adjustment of bobbin thread cam	2-A) Excessive tension is provided because of improper timing of the bobbin thread cam.	Refer to the standard adjustment values.
	2-3) Thread tension	3-A) Excessive thread tension	Reduce the tension in consideration of the tension balance with the needle thread.
	2-4) Thread	4-A) Poor quality of the thread	Use a high-quality thread.
	2-5) Needle heat	5-A) Thread cut occurs when the thread touches the right needle at sewing stop due to needle heat.	Reduce the sewing speed.
3. Needle breakage	3-1) Needle entry	1-A) Front/rear and right/left needle entry seems to be awkward in conjunction with the needle hole of the throat plate.	Refer to the standard adjustment values.
	3-2) Interference between lower looper and blindstitch of needle	2-A) The needle breaks because of the interference between the tip of the lower looper and the needle.	Adjust the lower looper to prevent the interference. Refer to the standard adjustment values.
	3-3) Interference between rear of lower looper and needle tip	3-A) The needle breaks because of the strong interference between the rear of the lower looper and the needle tip.	(6) Adjust the looper movement locus. Refer to the standard adjustment values.
	3-4) Rear needle guide	4-A) Excessive clearance between the needle and rear needle guide causes needle shaking and then interference between the needle and the lower looper tip resulting in needle breakage.	Adjust the clearance between the needle and rear needle guide. Refer to the standard adjustment values.
	3-5) Needle size	5-A) For the case that the needle is too thin for the material that is now used	Use a thicker needle.
	3-6) Thread tension	6-A) Excessive needle thread tension	Reduce the needle thread tension.
	3-7) Feed dog height	7-A) Too high feed tooth causes needle sidewise movement resulting in needle breakage.	Refer to the standard adjustment values.
4. Needle edge blunting	4-1) Needle entry	1-A) Front/rear and right/left needle entry seems to be awkward in conjunction with the needle hole of the throat plate.	Refer to the standard adjustment values.
	4-2) Rear needle guide	2-A) Improper position of the front-to-rear direction	Clearance check between rear needle guide and needle Refer to the standard adjustment values.
	4-3) Contact with the rear of the looper	3-A) Too often contact between the rear of the lower looper and the needle tip	(6) Adjust the looper movement locus to make the contact level appropriate when the lower looper moves backward. Refer to the standard adjustment values.

Trouble (1)	Trouble (2)	Cause (1)	Cause (2)	Check and corrective measures	
5. Stitch skipping	5-1) The looper does not scoop the needle thread.	1-A) Looper	A-1)The blade shape is not proper.	Regular parts are used	
		1-B) Needle	B-1)Needle bent or wrong mounting direction	Replacement of needles and installation of the needle hole section in the front shall be carried out correctly. UY130GS	
		1-C) Needle thread holder	C-1)Improper loop timing due to no use of the needle thread holder	Use the needle thread support plate to adjust the height properly. Refer to the adjustment values.	
		1-D) Needle thread adjusting path	D-1)Height of the thread path is insufficient.	Adjust the height properly. Refer to the adjustment values.	
		1-E) Needle height	E-1)Improper needle bar height	Needle bar height and looper drawing amount Confirmation Refer to the adjustment values.	
		1-F) Threading	F-1)Threading error	6. Refer to "How to conduct threading".	
		1-G) Needle heat	G-1)This problem occurs in a thick area of the denim material cloth.	Use needle cooling air. Refer to the adjustment values.	
		1-H) Lower looper adjustment	H-1)Improper clearance or excessive looper return	Reduce the looper return. Refer to the adjustment values.	
		1-I) Rear needle guide	I-1) Improper height or contact level	Height of main feed dog and longitudinal position check Refer to the adjustment values.	
	5-2) Chain stitch unthreading	<div style="border: 1px dashed black; padding: 5px; margin-bottom: 5px;"> (Chain stitch) The needle thread caught on the looper is unthreaded before the needle lowers and enters the needle thread loop. </div> <div style="border: 1px dashed black; padding: 5px;"> ③(unthreading) The needle thread loop caught on the looper is fully unthreaded before the needle lowers. </div>	2-A) Needle	A-1)Needle bent or mounting error	Replace the needle, or mount the needle hole in the front correctly. Then, insert the needle to the up end of the needle mounting hole of the needle stopper. UY130GS
			2-B) Needle height	B-1)Improper needle bar height	Needle bar height and looper drawing amount check Refer to the adjustment values.
			2-C) Threading	C-1)Threading error	6. Refer to "How to conduct threading".
			2-D) Lower looper	D-1)Improper lower looper mounting angle Insufficient lower looper drawing amount	Make the lower looper mounting angle proper or increase the drawing amount (in the flat mounting range).
			2-E) Lower looper adjustment	E-1)Insufficient contact level between the needle and the rear of the lower looper	Adjustment of looper movement locus Refer to the adjustment values.
			2-F) Thread tension	F-1)Insufficient thread tension	Increase the tension.
			2-G) Needle thread holder	G-1)Excessive height of thread holder position	Refer to the adjustment values.

To the next page

Trouble (1)	Trouble (2)	Cause (1)	Cause (2)	Check and corrective measures
-------------	-------------	-----------	-----------	-------------------------------

From the previous page

5-3) Poorly tense stitches for needle thread	3-A) Needle	A-1) Needle top blunting, needle bent, check the needle in use.	Replace the needle. UY130GS
	3-B) Lower looper	B-1) Lower looper blade point blunting or insufficient polishing	Replace any item if it has been modified or its shape has changed.
	3-C) Needle height	C-1) Improper needle bar height	Refer to the adjustment values.
	3-D) Threading	D-1) Threading error	6. Refer to "How to conduct threading".
	3-E) Needle thread tension	E-1) Insufficient thread tension	Increase the thread tension.
	3-F) Lower looper thread tension	F-1) Excessive thread tension	Reduce the thread tension.
	3-G) Bobbin thread guide path	G-1) Insufficient take-up amount of the bobbin thread	Increase the take-up amount of the bobbin thread.
	3-H) Bobbin thread cam	H-1) Delayed bobbin thread cam position	Advance the bobbin thread cam position to the proper level.
5-4) Sewing jam	4-A) Regulating spring of presser bar pressure	A-1) Insufficient presser bar pressure	Adjust the presser bar pressure properly.
	4-B) Feeder height	B-1) Extremely low feeder	Make the feeder height proper. Refer to the standard adjustment values.
	4-C) Pressure regulating spring of upper feed roller	C-1) Insufficient pressure adjustment	Adjust the presser bar pressure properly.
	4-D) Upper feed roller	D-1) Insufficient drawing amount	Adjust the drawing amount properly.
5-5) Problems with chain-off thread	5-A) Throat plate	A-1) Not smooth thread running due to blunt throat needle hole	Perform modification or replace the deformed part.
	5-B) Lower looper adjustment	B-1) Lower fancy stitch skipping due to insufficient lower looper adjustment	Refer to the adjustment values.
	5-C) Needle thread tension	C-1) Insufficient needle thread tension	Increase the thread tension.
	5-D) Threading	D-1) Threading error	6. Refer to "How to conduct threading".
	5-E) Drawing amount of upper feed roller	E-1) The thread drawing amount is insufficient.	Increase the thread drawing amount. Refer to the adjustment values.
	5-F) Clearance toward the upper feed roller	F-1) Clearance is too much between the upper feed roller and the upper face of the throat plate.	Adjust the clearance to a standard level. Refer to the adjustment values.
	5-G) Pressure regulating spring of upper feed roller	G-1) Insufficient pressure adjustment	Adjust the presser bar pressure properly.

This manual uses environment-friendly soyink.

JUKI[®]
Union Special
JUKI CORPORATION



JUKI CORPORATION HEAD OFFICE

The environmental management system to promote and conduct
①the technological and technical research, the development and design of the products in which the environmental impact is considered.
②the conservation of the energy and resources, and the recycling, in the research, development, design, distribution, sale and maintenance service of the industrial sewing machines, household sewing machines and industrial-use robots, etc. and in the sale and maintenance service of data entry system and in the purchase, distribution and sale of the household commodities including the healthcare products.



Please do not hesitate to contact our distributors or agents in your area for further information when necessary.

* **The description covered in this engineer's manual is subject to change for improvement of the commodity without notice.**