

PFAFF

1051

1053

Teileliste

Parts list

Liste de pièces

Lista de piezas

1181

1183

Diese Teileliste hat für Maschinen ab nachfolgender
Seriennummer Gültigkeit:

This parts list applies to machines from the following
serial numbers onwards:

Cette liste de pièces est valable pour les machines au
numéros de série à partir de:

Esta lista de piezas tiene validez para máquinas a partir del
número de serie siguiente:

PFAFF 1051 # 2232500 →

PFAFF 1053 # 2232222 →

PFAFF 1181 # 2232501 →

PFAFF 1183 # 2232224 →

Alle Informationen und Abbildungen waren zum Zeitpunkt der Druckgebung auf dem neusten Stand.

Technische Änderungen vorbehalten!

Der Nachdruck, die Vervielfältigung sowie die Übersetzung - auch auszugsweise - aus PFAFF-Teilelisten ist nur mit unserer vorherigen Zustimmung und mit der Quellenangabe gestattet.

At the time of printing, all information and illustrations contained in this document were up to date.

Subject to alteration!

The reprinting, copying or translation of PFAFF Parts lists whether in whole or in part, is only permitted with our previous permission and with written reference to the source.

Au moment de la remise à l'imprimeur, toutes les informations et figures se rapportant à cette machine correspondaient à l'état actuel des connaissances.

Sous réserve de modifications techniques!

Aucune reproduction, photocopie ou traduction - même par extraits - des listes de pièces PFAFF ne peut être effectuée, à condition d'en indiquer l'origine, sans notre autorisation expresse.

Todas las informaciones e ilustraciones de este manual estaban al día en el momento de entregarse para su impresión.

¡ Salvo modificaciones técnicas!

La reimpresión, reproducción y traducción - aunque sólo sea parcial - de las listas de piezas PFAFF sólo está permitida con nuestro permiso previo e indicando la fuente.

**G.M. PFAFF KAISERSLAUTERN
INDUSTRIEMASCHINEN AG**

Postfach 3020
D-67653 Kaiserslautern

Königstr. 154
D-67655 Kaiserslautern

Redaktion/Illustration
Verlag Technische Dokumentation
Postfach 1106
D-77901 Lahr

		Seite Page Page Página
0	Wichtiger Hinweis Important note Avis important Observación importante	0 - 1
1	Vorwort Foreword Avant-propos Notas preliminares	1 - 1
2	Erläuterungen der Schlüsselzeichen Explanation of key markings Explication des symboles Explicaciones de los signos clave	2 - 1
3	Basismaschine Basic machine Machine de base Máquina básicas	
3.01	Gehäuseteile Housing sections Parties du corps Piezas del cárter	3 - 1
3.02	Kopfteile Needle head parts Pièces de tête Piezas de la cabeza	3 - 2
3.03	Armteile Arm parts Pièces de bras Piezas del brazo	3 - 6
3.04	Grundplattenteile Bedplate parts Pièces du plateau fondamental Piezas del cárter	3 - 14
4	Kanten-Beschneideeinrichtung (-731/01) Edge trimmer (-731/01) Couteau (-731/01) Recortador (-731/01)	4 - 1

		Seite Page Page Página
5	Fadenabschneid-Einrichtung (-900/24) Thread trimmer (-900/24) Coupe-fil (-900/24) Cortahilos (-900/24)	5 - 1
6	Fadenabstreif-Einrichtung(-909/04) Thread wiper (-909/04) Racleur de fil (-909/04) Retirahilos (-909/04)	6 - 1
7	Presserfuß-Automatik (-910/06) Automatic presser foot lifter (-910/06) Relève-pied automatique (-910/06) Grupo acondicionador del aire comprimido (-910/06)	7 - 1
8	Verriegelungs-Einrichtung (-911/37) Backtacking mechanism (-911/37) Dispositif à points d'arrêt (-911/37) Rematador (-911/37)	8 - 1
9	Elektrische Ausrüstung Electrical equipment Équipement électrique Equipo eléctrico	
9.01	Kabelbaum zum Oberteil Cable tree to sewing head Faisceau de câbles vers la tête de machine Mazo de cables para el cabezal	9 - 1
9.02	Tastenschalter Push-button Interrupteur à bouton-poussoir Interruptor pulsador	9 - 2
9.03	Bedienfeld Control panel Panneau de commande Panel de mandos	9 - 2
9.04	Einbaumotor Built-in motor Moteur incorporé Motor incorporado	9 - 3

	Seite Page Page Página
9.05 Sollwertgeber Set-point generator Codeur Emisor del valor teórico	9 - 4
9.06 Steuergerät Control device Boîte de commande Caja de mandos	9 - 5
10 Garnrollenständer Reel stands Porte-bobines Portacarretes	10 - 1
11 Einstellehren Adjustment gauges Calibres Calibres de ajuste	11 - 1
12 Teile zur Tischplatte Parts for table top Pièces du plateau Piezas para el tablero	11 - 1
13 Keilriemen V-belt Courroie trapézoïdale Correa trapezoidal	13 - 1
14 Knielüfterteile Knee lifter parts Pièces du releveur de genouillère Piezas del alzaprensateñas por rodillera	13 - 1
15 Schmiermittel-Übersicht Overview of lubricants Tableau de lubrifiants Tabla de lubricantes	15 - 1
16 Optionen Options Options Opciones	

	Seite Page Page Página
16.01 Anbausatz für integrierten Motor Mounting kit for integrated motor Jeu de pièces pour moteur intégré Juego de piezas acoplables para motor integrado	16 - 1
17 Index (Teilenummern / Seitenzahlen) Index (part numbers / page numbers) Index (numéros de pièces, de pages) Index (números de pieza / números de página)	17 - 1
18 Unterklassen-Ausstattung Subclass parts Composition des sous-classes Composición de las subclases	
18.01 Nähwerkzeuge (PFAFF 1051;1181) Gauge parts (PFAFF 1051;1181) Organes de couture (PFAFF 1051;1181) Organos de costura (PFAFF 1051;1181)	18 - 2
18.02 Nähwerkzeuge (PFAFF 1053;1183) Gauge parts (PFAFF 1053;1183) Organes de couture (PFAFF 1053;1183) Organos de costura (PFAFF 1053;1183)	18 - 5

Achtung!



Wir machen ausdrücklich darauf aufmerksam, daß Ersatz- und Zubehörteile, die nicht von uns geliefert werden, auch nicht von uns geprüft und freigegeben sind. Der Einbau und / oder die Verwendung solcher Produkte kann daher u. Umständen konstruktiv vorgegebene Eigenschaften Ihrer Maschine negativ verändern. Für Schäden, die durch die Verwendung von Nicht-Originalteilen entstehen, übernehmen wir keine Haftung!

Caution!



We warn you expressively that spare parts and accessories that are not supplied by us are not tested and released by us. Fitting or using these products may therefore have negative influences on features that depend on the machine design. We are not liable for any damage caused by the use of non-Pfaff parts!

Attention!



Nous attirons expressément votre attention sur le fait que les pièces de rechange et accessoires qui n'ont pas été livrés par nous n'ont pas non plus été contrôlés et agréés par nous. C'est pourquoi le montage et/ou l'utilisation de telles pièces peut éventuellement entraîner l'altération des caractéristiques de construction de votre machine. Par conséquent, nous n'assumons aucune responsabilité pour les dommages causés par l'emploi de pièces qui ne sont pas d'origine!

¡Atención!



Se hace observar que en el caso de piezas de recambio y accesorios que no hayan sido suministrados por nosotros, quiere decir que non han sido sometidas por nuestra parte a un control y que no se les ha dado el visto bueno. Por esta razón, el montaje y/o empleo de tales productos puede repercutir negativamente en las características previstas en su máquina. ¡Para los daños que eventualmente pudiesen presentarse al utilizar piezas no originales, no asumimos ninguna garantía!

- Die Seriennummer der Maschine, für die diese Teileliste Gültigkeit hat, ist auf der Titelseite aufgeführt.
 - Alle Teile sind so abgebildet, wie sie in der Maschine funktionsmäßig zusammengehören.
 - Gestrichelt dargestellte Teile zeigen angrenzende Teile aus anderen Funktionsgruppen.
 - Im oberen Teil der Bildseiten befindet sich eine Gesamtansicht der Maschine .
 - Der Einbauort der dargestellten Teile wird durch eine gerasterte Fläche gekennzeichnet.
 - Einrahmungen auf den Bildseiten zeigen, aus welchen Einzelteilen sich die Gruppenteile zusammensetzen.
 - Die auf den Bildseiten verwendeten Schlüsselzeichen (; 2 ; 3 usw.) sind im Kapitel "Erläuterungen der Schlüsselzeichen" aufgelistet.
-
- The serial number of the machine to which this parts list applies is indicated on the cover page.
 - All parts are illustrated in function groups with the parts which they function together with in the machine.
 - Parts illustrated with broken lines are parts from other function groups which border on the illustrated function group.
 - The above section of the page of illustrations contains a total view of the machine. The place for the installation of the parts pictured here is marked by the grid.
 - The framed-in sections on the illustration pages show the individual parts comprising a group.
 - The key markings used on the illustrated pages (; 2 ; 3 etc.) are listed in the chapter "Explanation of key markings".
-
- Le numéro de série de la machine pour laquelle cette liste de pièces est valable est indiqué sur la première page.
 - Toutes les pièces sont représentées en fonction de leur groupement fonctionnel dans la machine.
 - Les pièces hâchurées indiquent les pièces limitrophes de groupes de fonctions différents.
 - La partie supérieure des pages de figures comprend une présentation globale de la machine. L'emplacement des pièces représentées est signalé par quadrillages.
 - Les parties encadrées sur les pages à illustrations représentent les pièces individuelles formant groupe.
 - Vous trouverez au chapitre "Explication des symboles" une liste des symboles utilisés sur les pages de figures (; 2 ; 3 etc.)
-
- El número de serie de la máquina para la cual tiene validez esta lista de piezas va indicado en la página de título.
 - Todas las piezas están ilustradas tal como aparecen en la máquina para su funcionamiento.
 - Las piezas representadas con rayitas muestran piezas colindantes de otros grupos de funciones.
 - En la parte superior de las páginas ilustradas se puede ver una vista en conjunto de la máquina.
 - El lugar de montaje de la pieza representada va caracterizada mediante una superficie reticulada.
 - Los recuadros en las páginas ilustradas indican las piezas individuales de que se componen los grupos.
 - Los signos clave (; 2 ; 3 etc.) empleados en las páginas con ilustraciones van listados en el capítulo "Explicaciones de los signos clave".

- Unterklassenabhängig, Teilenummer siehe Unterklassen-Ausstattung.
Subclas-dependent, for part number see subclass parts listing.
Fonction de la sous-classe; pour le numéro de la pièce, voir "Equipement de sous-classes".
Dependientes de la subclase, para el número de pieza véase "Dotación de subclases".
- A Maschinen-Ausstattung für feine Materialien.
Model A for sewing thin and light-weight materials.
Modèle A pour la couture de tissus fins et légers.
Tipo A para materiales ligeros.
- B Maschinen-Ausstattung für mittlere Materialien.
Model B for sewing thin and medium-weight materials.
Modèle B pour la couture de matières moyennes.
Tipo B para materiales semiligeros.
- C Maschinen-Ausstattung für mittelschwere Materialien.
Model C for sewing medium-heavy materials.
Modèle C pour la couture de matières mi-lourdes.
Tipo C para materiales semipesados.
- N Stichlänge 6,0 mm.
Stitch length 6.0 mm.
Longeur du point 6,0 mm.
Largo de puntada 6,0 mm.
- 2 Markierung (Punkte, Striche oder Zahl) bei Bestellung angeben.
Marking (dots, strokes or numbers) to be stated on order.
Préciser les repères (points, traits ou chiffres) à la commande.
Señales (puntos, rayas o cifras), indíquese en los pedidos.
- 3/4 Selbstklebend
Self-adhesive
Auto-adhésive
Autoadhesivo
- 6 Nadeldicke und Spitzenform bei Bestellung angeben.
Needle size and style of point to be stated on order.
Préciser la grosseur de l'aiguille et la forme de la pointe à la commande.
Grosor de aguja y forma de la punta, indíquese en los pedidos.
- 6/3 Für 1,64 mm Nadelkolbendicke
For needle thickness of 1.64 mm
Pour grosseur d'aiguille 1,64 mm
Para 1,64 mm de grosor de aguja

- 6/4 Für 2,00 mm Nadelkolbendicke
For needle thickness of 2.00 mm
Pour grosseur d'aiguille 2,00 mm
Para 2,00 mm de grosor de aguja
- 27/5 Eingeklammerte Zahl = Länge in mm.
Number in brackets = length in mm.
Chiffre entre parenthèses = longueur en mm.
Cifra entre paréntesis = largura en mm.
- 40/3 Fetten mit 28-011 202-69; Bestellnummer siehe Seite 15 - 1.
Grease with 28-011 202-69; for part number see page 15 - 1.
Graisser avec de la graisse 28-011 202-69; n° de commande, voir page 15 - 1.
Engrase con grasa 28-011 202-69; para el número de pedido véase la página 15 - 1.
- 40/13 Fetten mit 28-011 202-05; Bestellnummer siehe Seite 15 - 1.
Grease with 28-011 202-05; for part number see page 15 - 1.
Graisser avec de la graisse 28-011 202-05; n° de commande, voir page 15 - 1.
Engrase con grasa 28-011 202-05; para el número de pedido véase la página 15 - 1.
- 40/23 Tränken mit 28-011 201-05; Bestellnummer siehe Seite 15 - 1.
Grease with 28-011 201-05; for part number see page 15 - 1.
Graisser avec de la graisse 28-011 201-05; n° de commande, voir page 15 - 1.
Engrase con grasa 28-011 201-05; para el número de pedido véase la página 15 - 1.
- 40/24 Ölen mit 28-011 201-05; Bestellnummer siehe Seite 15 - 1.
Oil with 28-011 201-05; for part number see page 15 - 1.
Huiler avec de la graisse 28-011 201-05; n° de commande, voir page 15 - 1.
Lubrifique con grasa 28-011 201-05; para el número de pedido véase la página 15 - 1.
- 40/25 Füllen mit 28-011 201-05; Bestellnummer siehe Seite 15 - 1.
Top up with 28-011 201-05; for part number see page 15 - 1.
Remplir de 28-011 201-05; n° de commande, voir page 15 - 1.
Rellene con 28-011 201-05; para el número de pedido véase la página 15 - 1.
- 96 Länge angeben.
State length.
Préciser longueur.
Indíquese la largura.

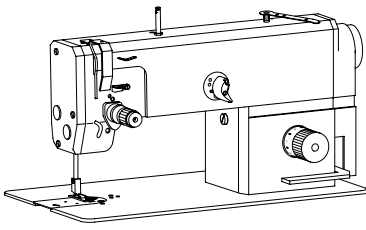

Gehäuseteile PFAFF 1051
 Housing sections PFAFF 1053
 Parties du corps PFAFF 1181
 Piezas del cárter PFAFF 1183

3.01

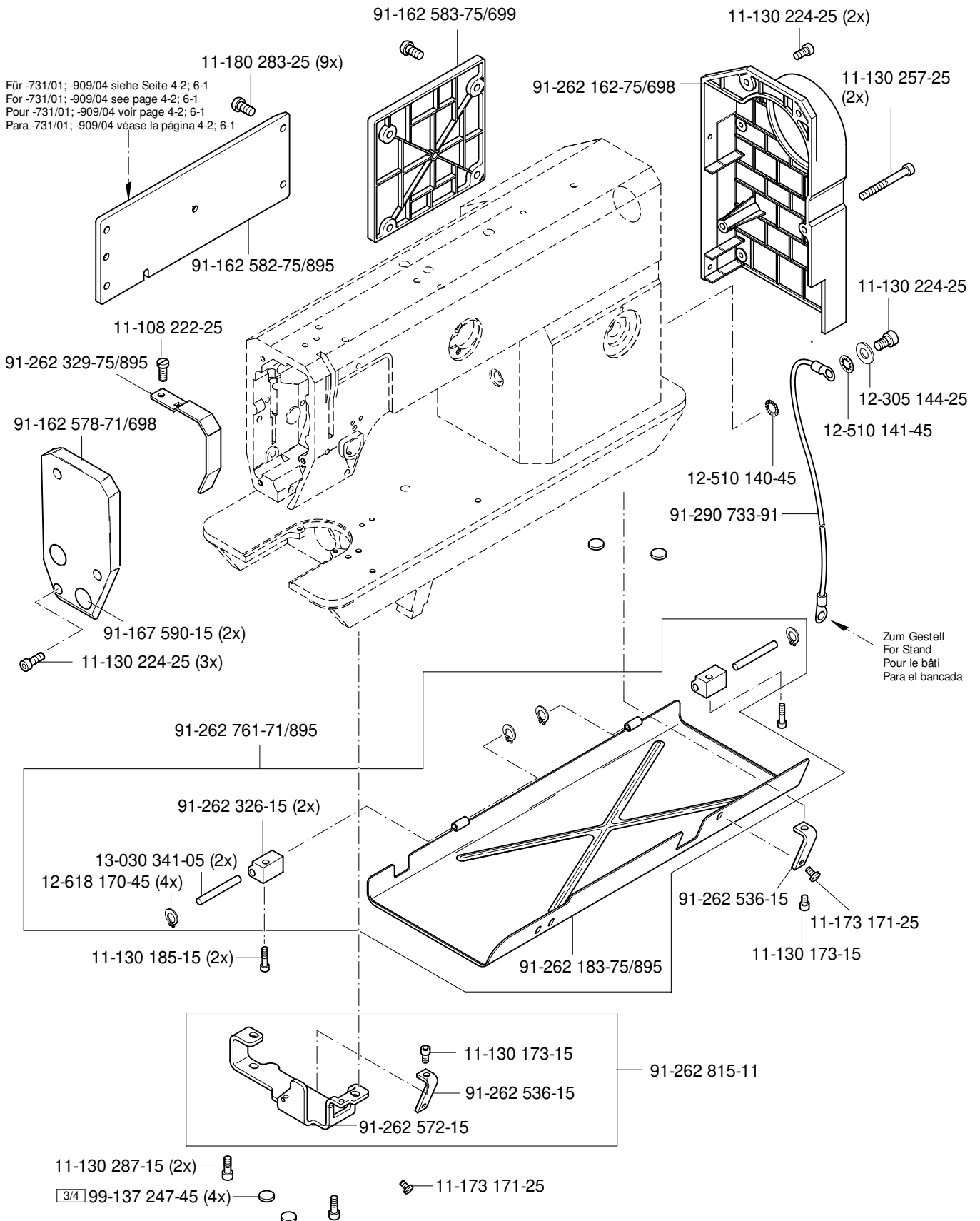

3.02

Kopfteile
Needle head parts
Pièces de tête
Piezas de la cabeza

PFAFF 1051
PFAFF 1053
PFAFF 1181
PFAFF 1183

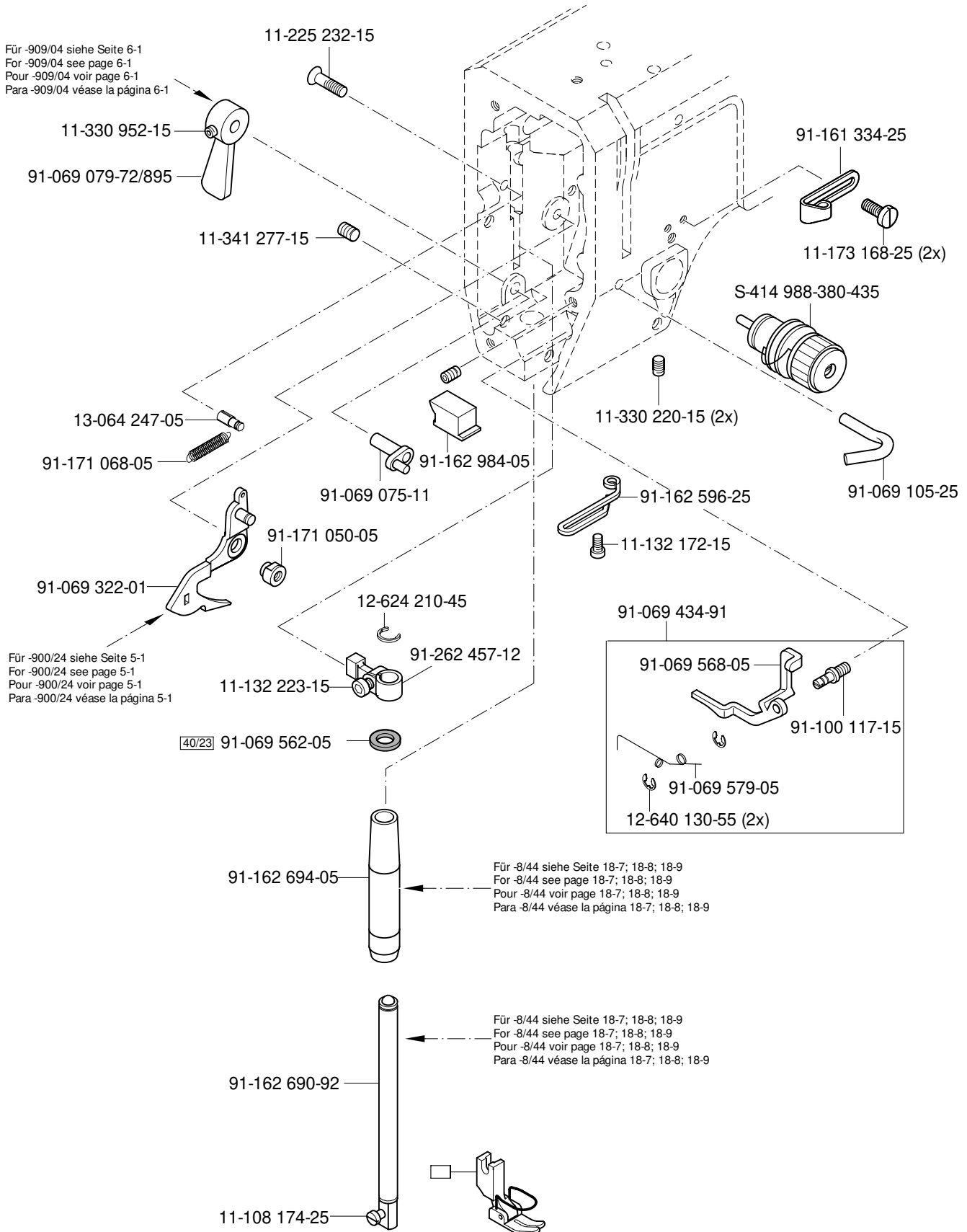
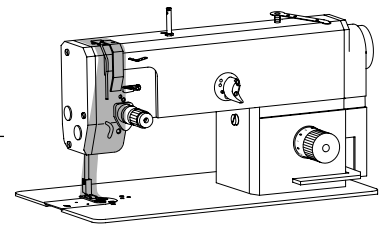

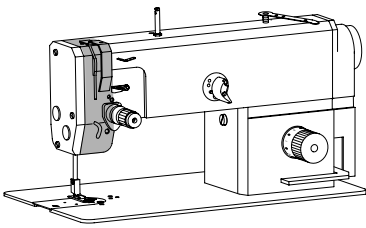

Kopfteile
Needle head parts
Pièces de tête
Piezas de la cabeza

PFAFF 1051
PFAFF 1053
PFAFF 1181
PFAFF 1183

3.02

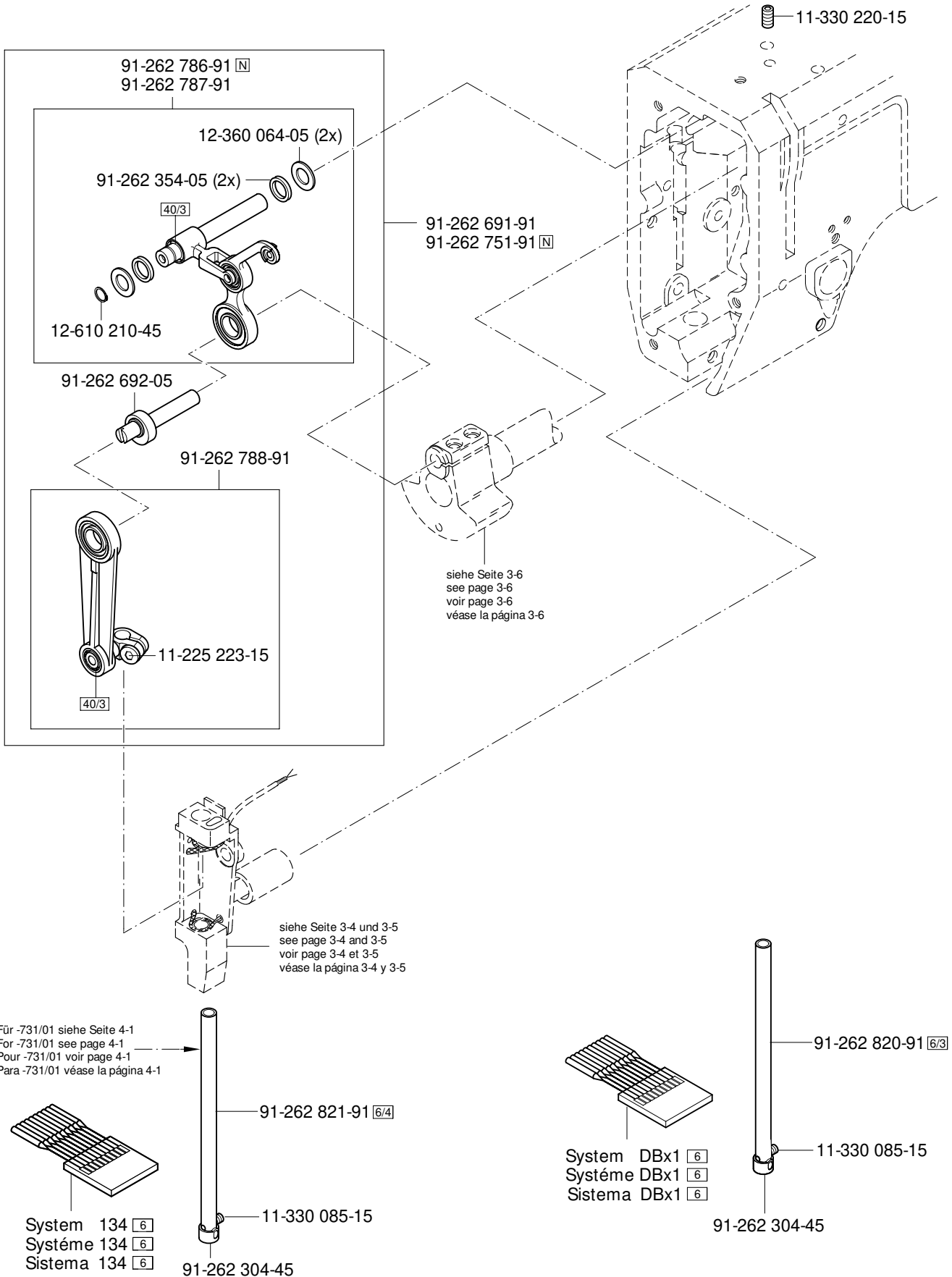

3.02

Kopfteile
Needle head parts
Pièces de tête
Piezas de la cabeza

PFAFF 1051
PFAFF 1181

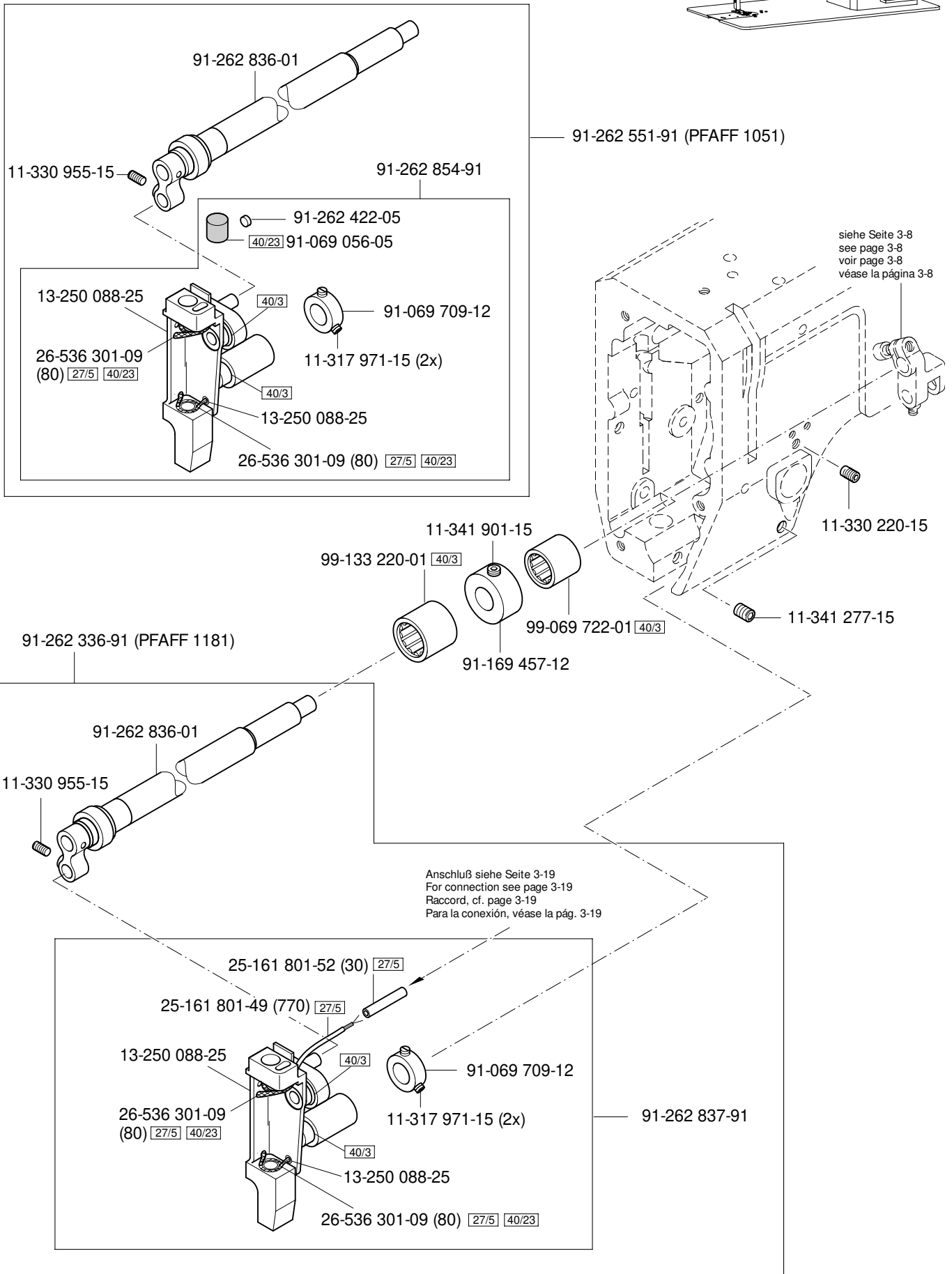
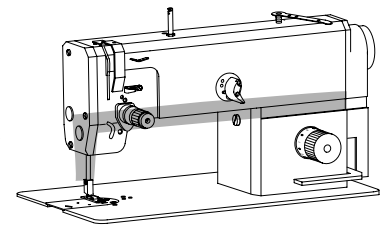

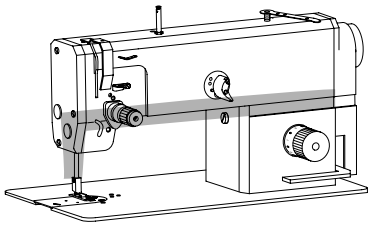

Kopfteil
Needle head parts
Pièces de tête
Piezas de la cabeza

PFAFF 1053
PFAFF 1183

3.02

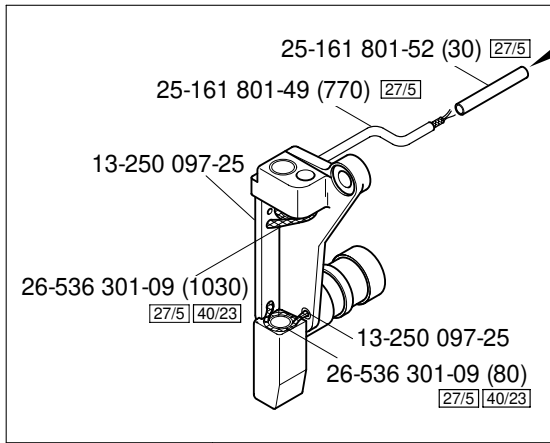

91-262 320-91 (PFAFF 1183)

Anschluß siehe Seite 3-19
For connection see page 3-19
Raccord, cf. page 3-19
Para la conexión, véase la pág. 3-19

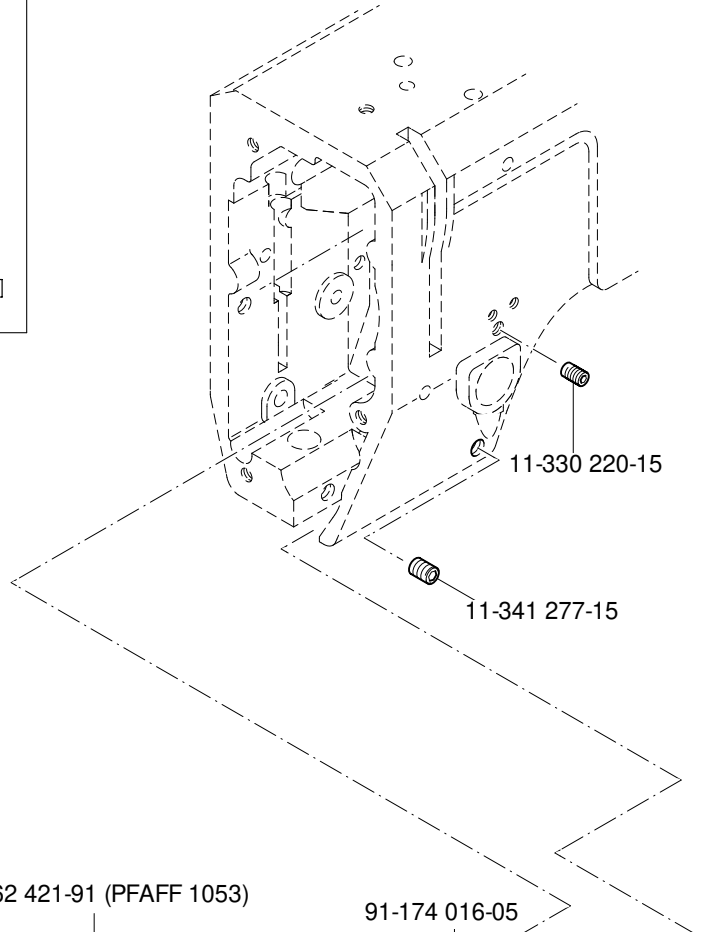

siehe Seite 3-3
see page 3-3
voir page 3-3
véase la página 3-3

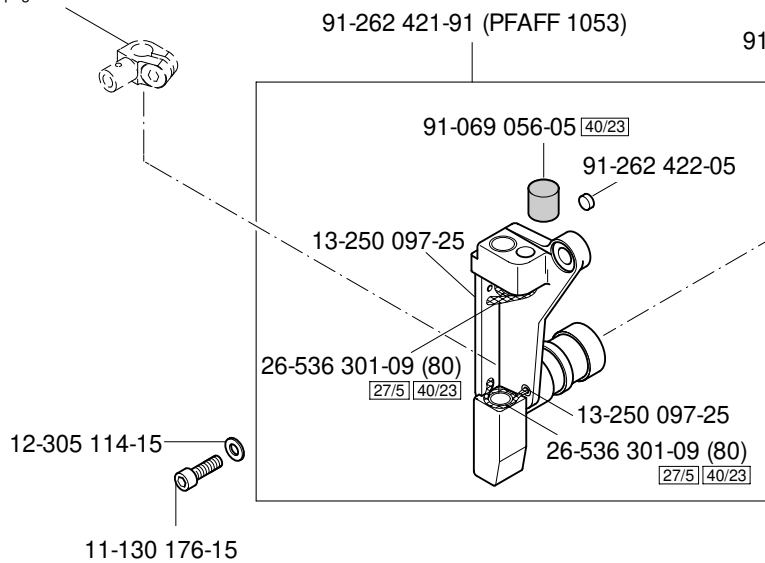

3.03

Armteile	PFAFF 1051
Arm parts	PFAFF 1053
Pièces de bras	PFAFF 1181
Piezas del brazo	PFAFF 1183

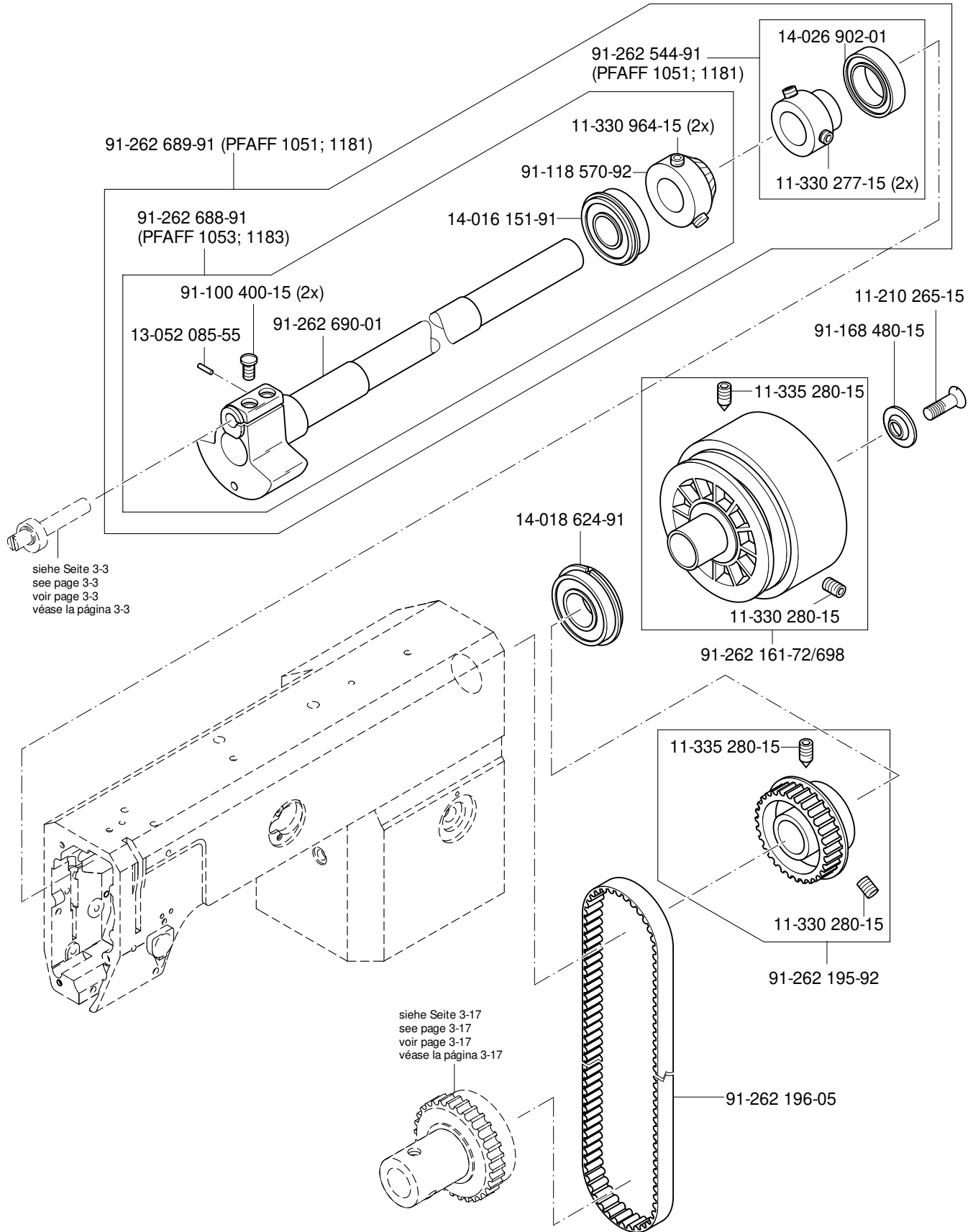
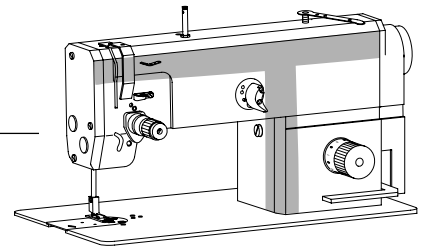

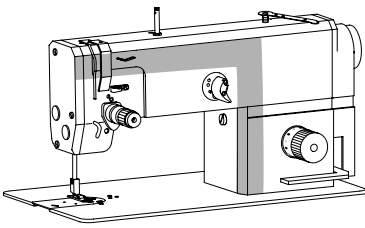

Armteile
 Arm parts
 Pièces de bras
 Piezas del brazo

PFAFF 1051
 PFAFF 1053
 PFAFF 1181
 PFAFF 1183

3.03

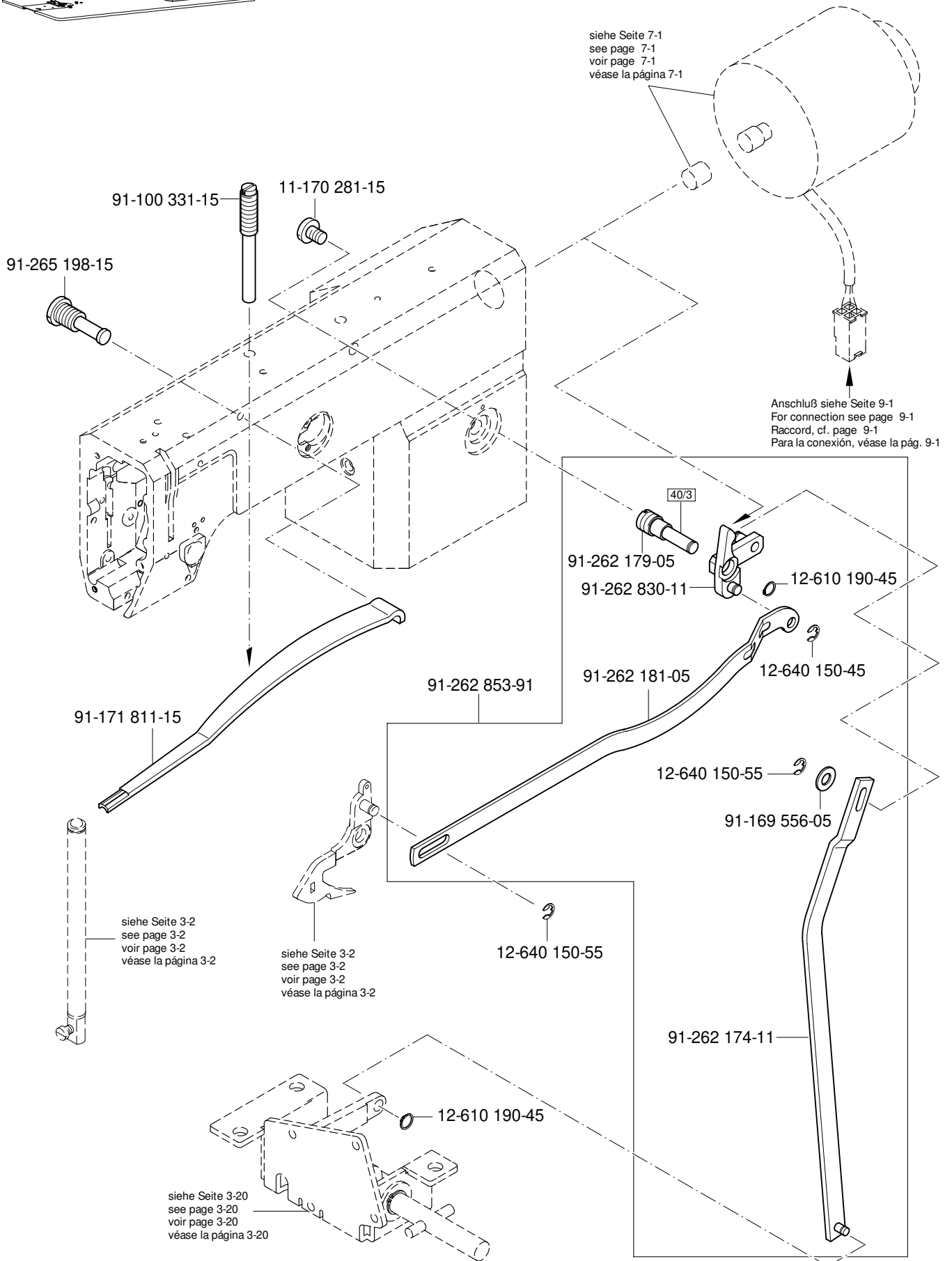

3.03

Armteile
 Arm parts
 Pièces de bras PFAFF 1051
 Piezas del brazo PFAFF 1181

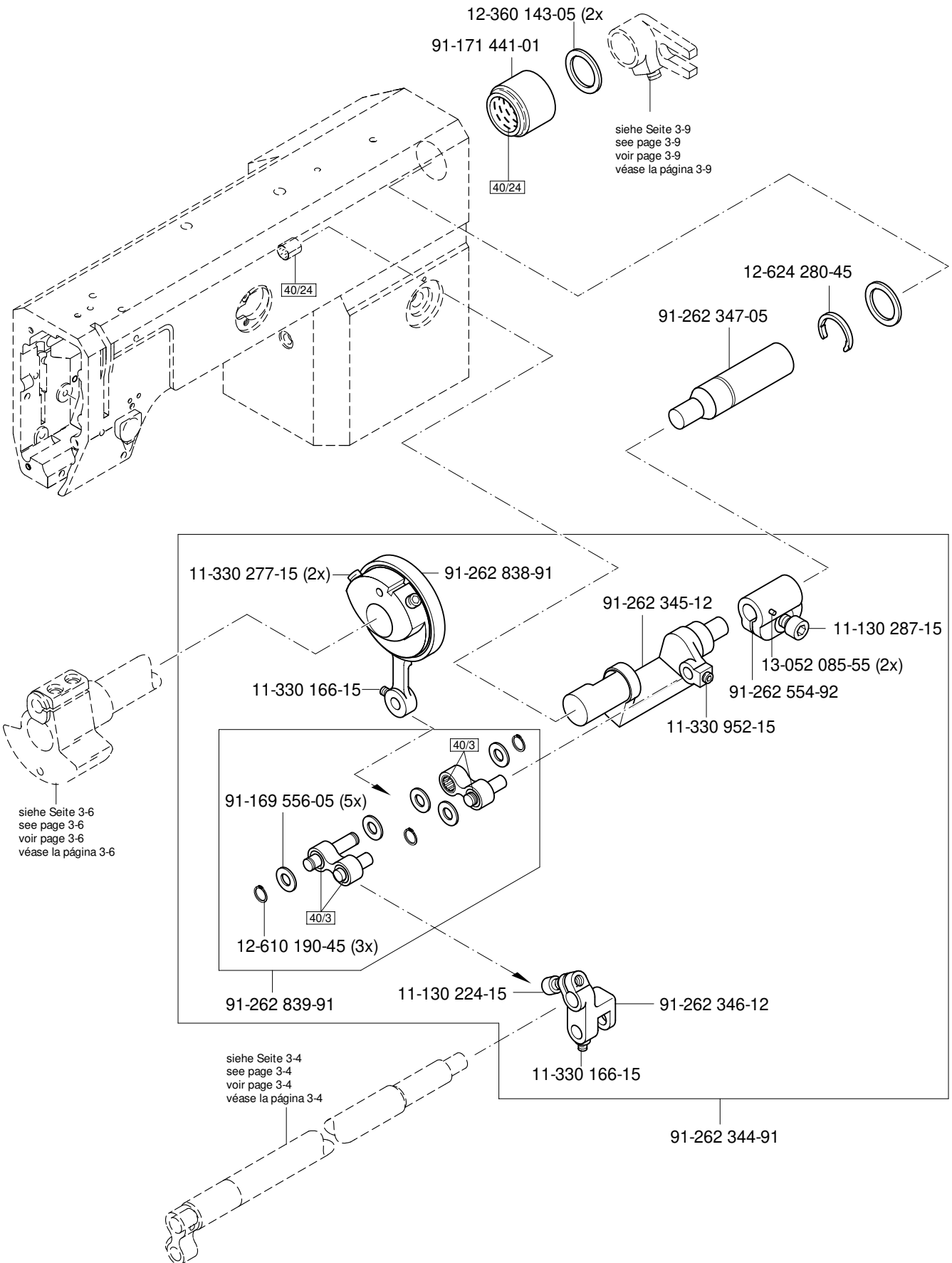
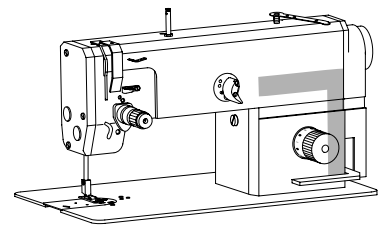

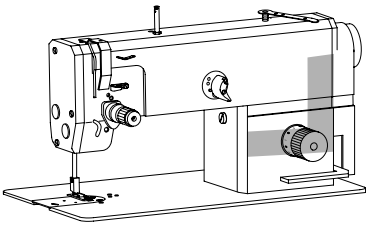

Armteile
 Arm parts
 Pièces de bras
 Piezas del brazo

PFAFF 1051
 PFAFF 1181

3.03

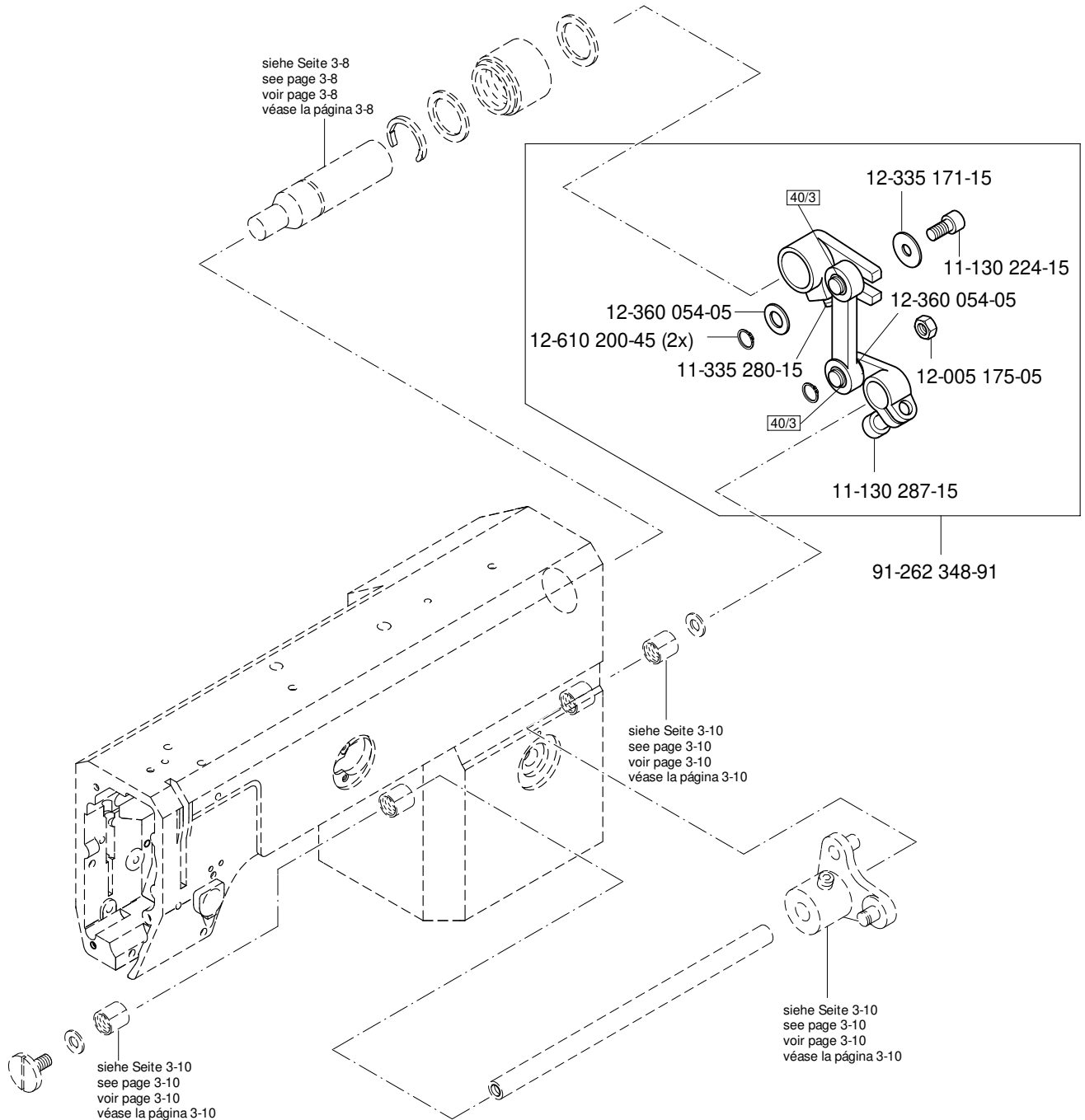

3.03

Armteile PFAFF 1051
 Arm parts PFAFF 1053
 Pièces de bras PFAFF 1181
 Piezas del brazo PFAFF 1183

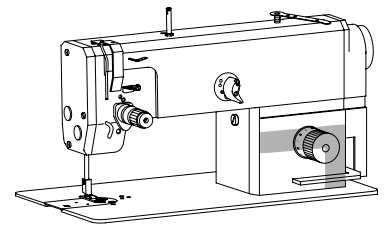

PFAFF 1053
 PFAFF 1183

11-320 171-15



12-710 901-22

12-360 063-05

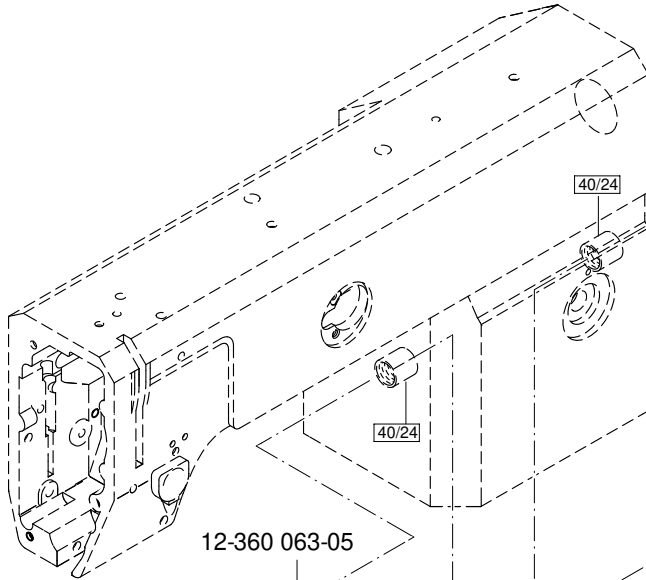

40/24

40/24

12-360 063-05

siehe Seite 3-12
 see page 3-12
 voir page 3-12
 véase la página 3-12

siehe Seite 3-11
 see page 3-11
 voir page 3-11
 véase la página 3-11

11-178 223-25

91-262 218-05



91-262 813-91

11-330 277-15 (2x)

91-262 210-92

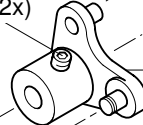

91-262 760-91

siehe Seite 3-18
 see page 3-18
 voir page 3-18
 véase la página 3-18

12-640 170-55

12-640 150-55

91-262 222-05 40/3

91-262 219-91

91-262 278-11

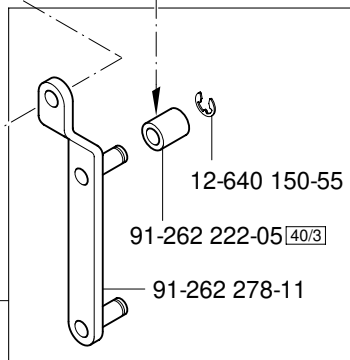

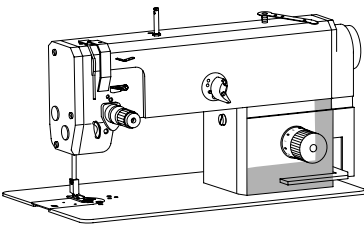

Armteile PFAFF 1051
 Arm parts PFAFF 1053
 Pièces de bras PFAFF 1181
 Piezas del brazo PFAFF 1183

3.03

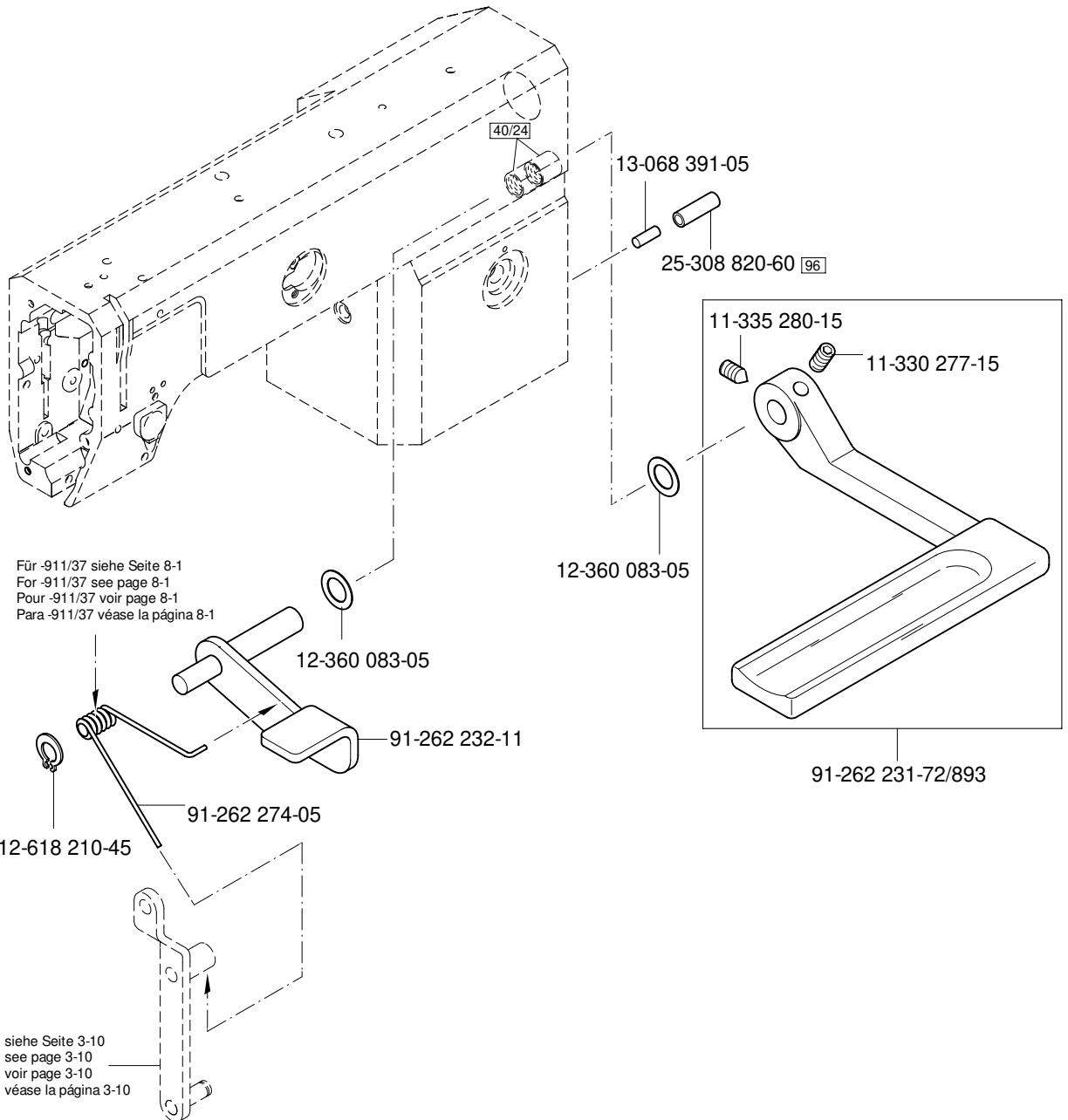

3.03

Armteile
 Arm parts
 Pièces de bras
 Piezas del brazo

PFAFF 1051
 PFAFF 1053
 PFAFF 1181
 PFAFF 1183

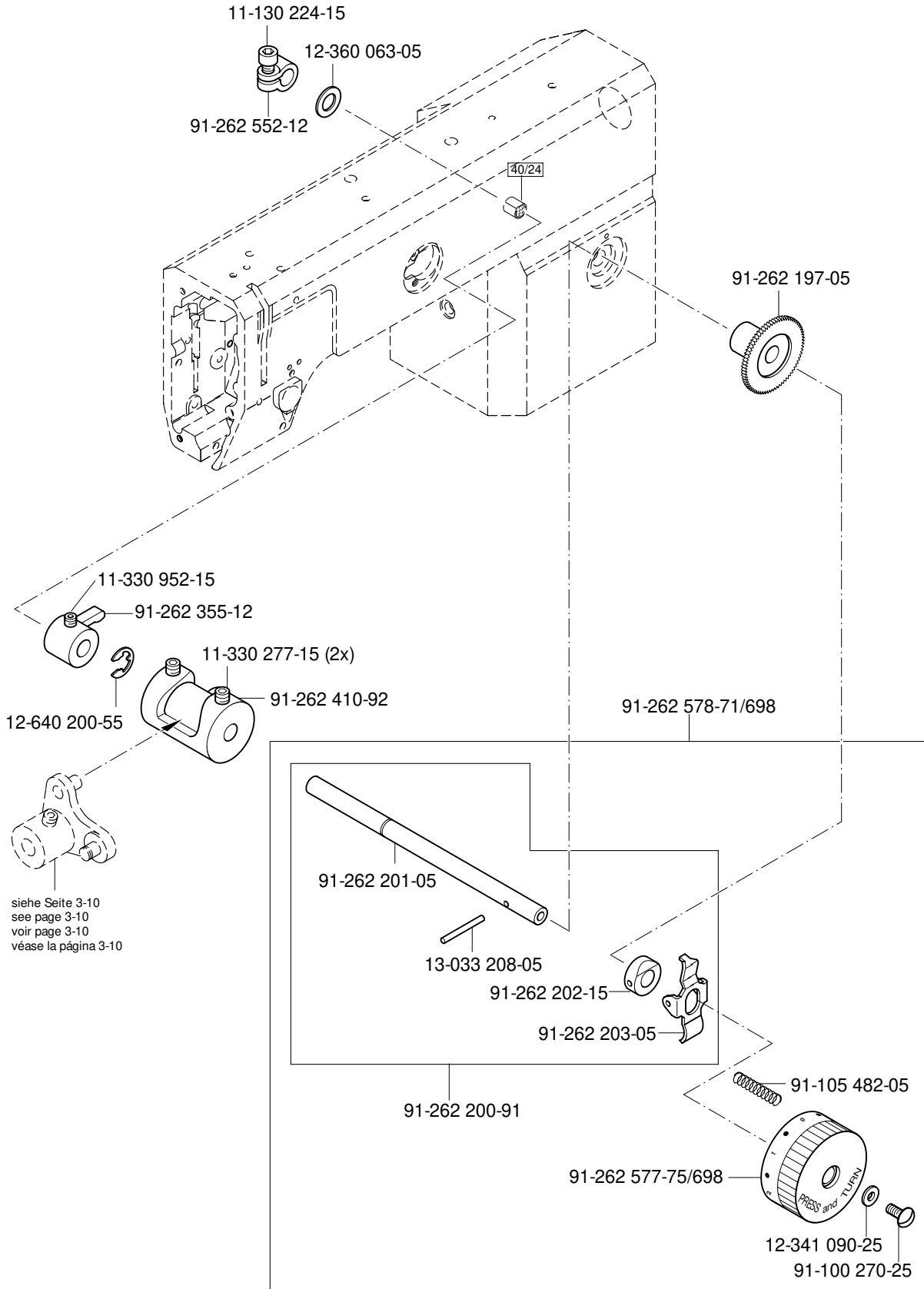
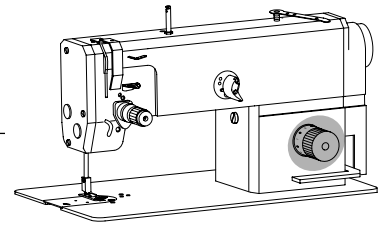

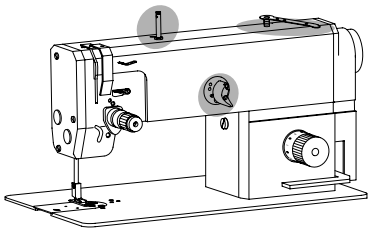

Armteile
 Arm parts
 Pièces de bras
 Piezas del brazo

PFAFF 1051
 PFAFF 1053
 PFAFF 1181
 PFAFF 1183

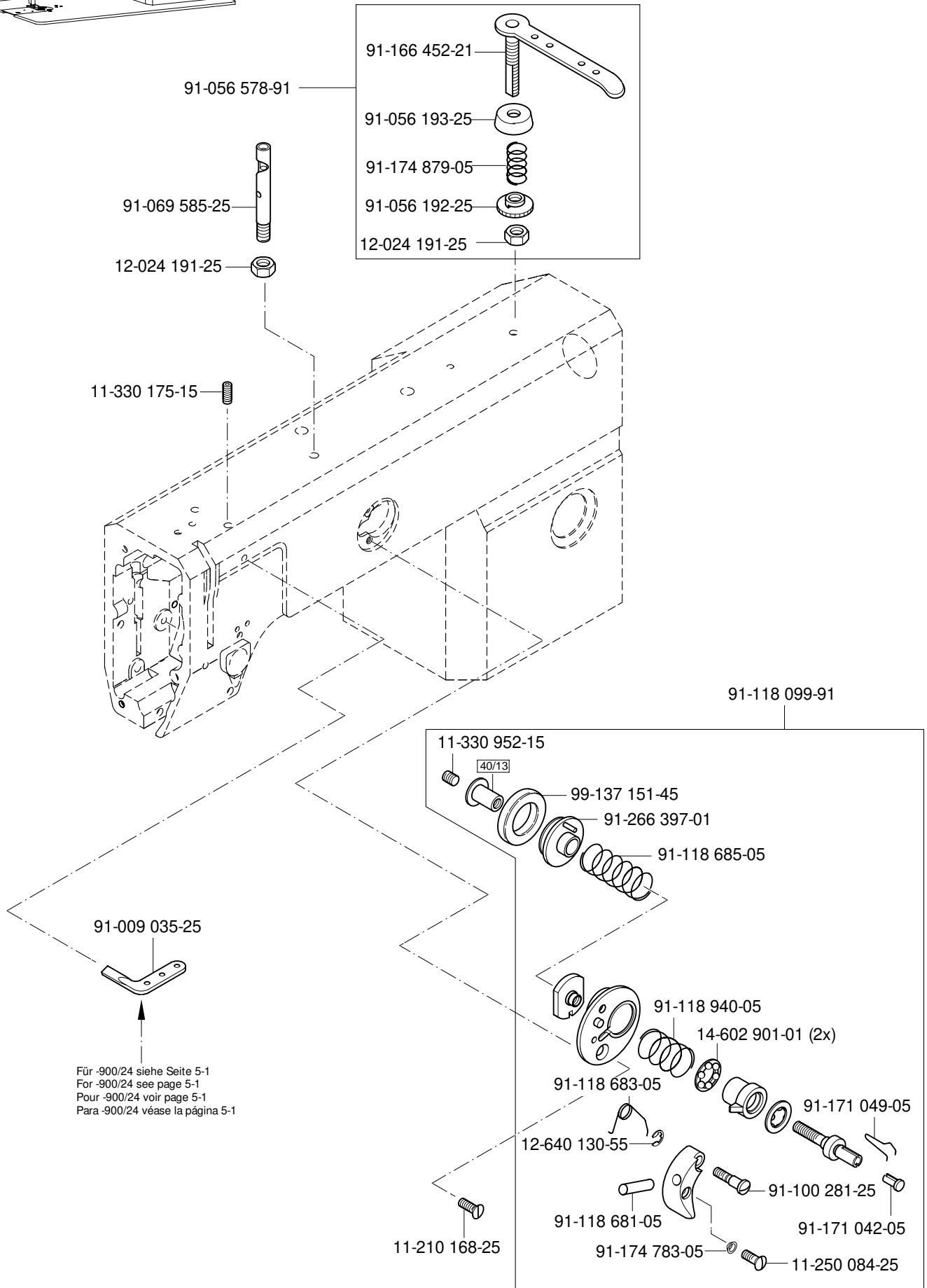

Für -900/24 siehe Seite 5-1
 For -900/24 see page 5-1
 Pour -900/24 voir page 5-1
 Para -900/24 véase la página 5-1

3.04

Grundplattenteile
Bedplate parts
Pièces du plateau fondamental
Piezas del cárter

PFAFF 1051
PFAFF 1053
PFAFF 1181
PFAFF 1183

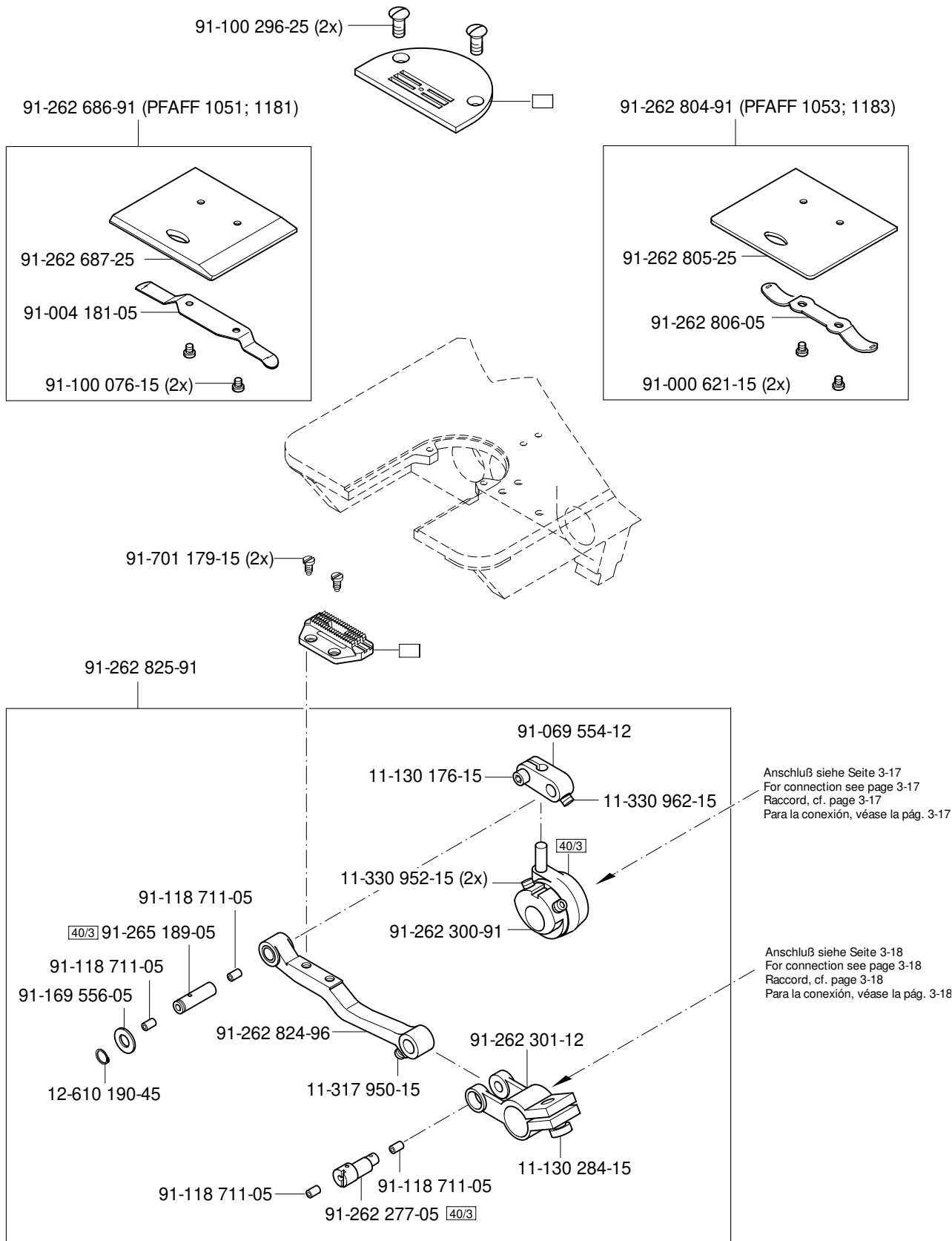
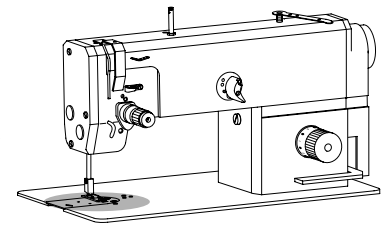

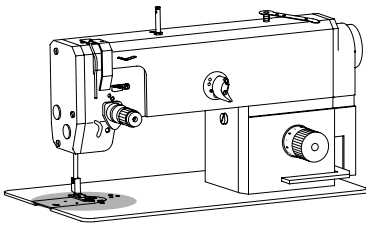

Grundplattenteile
 Bedplate parts
 Pièces du plateau fondamental
 Piezas del cárter

PFAFF 1051
 PFAFF 1053

3.04

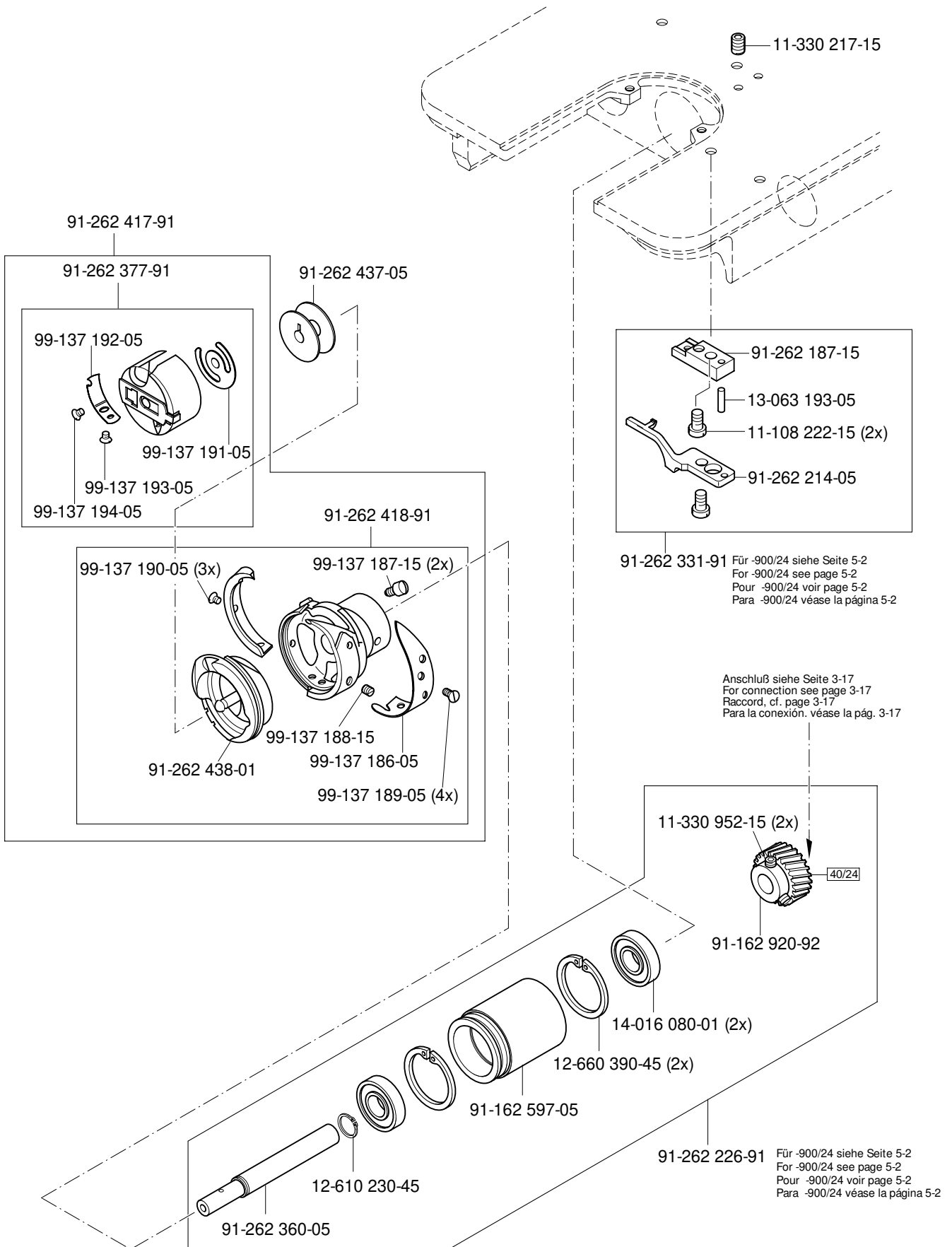

3.04

Grundplattenteile
Bedplate parts
Pièces du plateau fondamental
Piezas del cárter

PFAFF 1181
PFAFF 1183

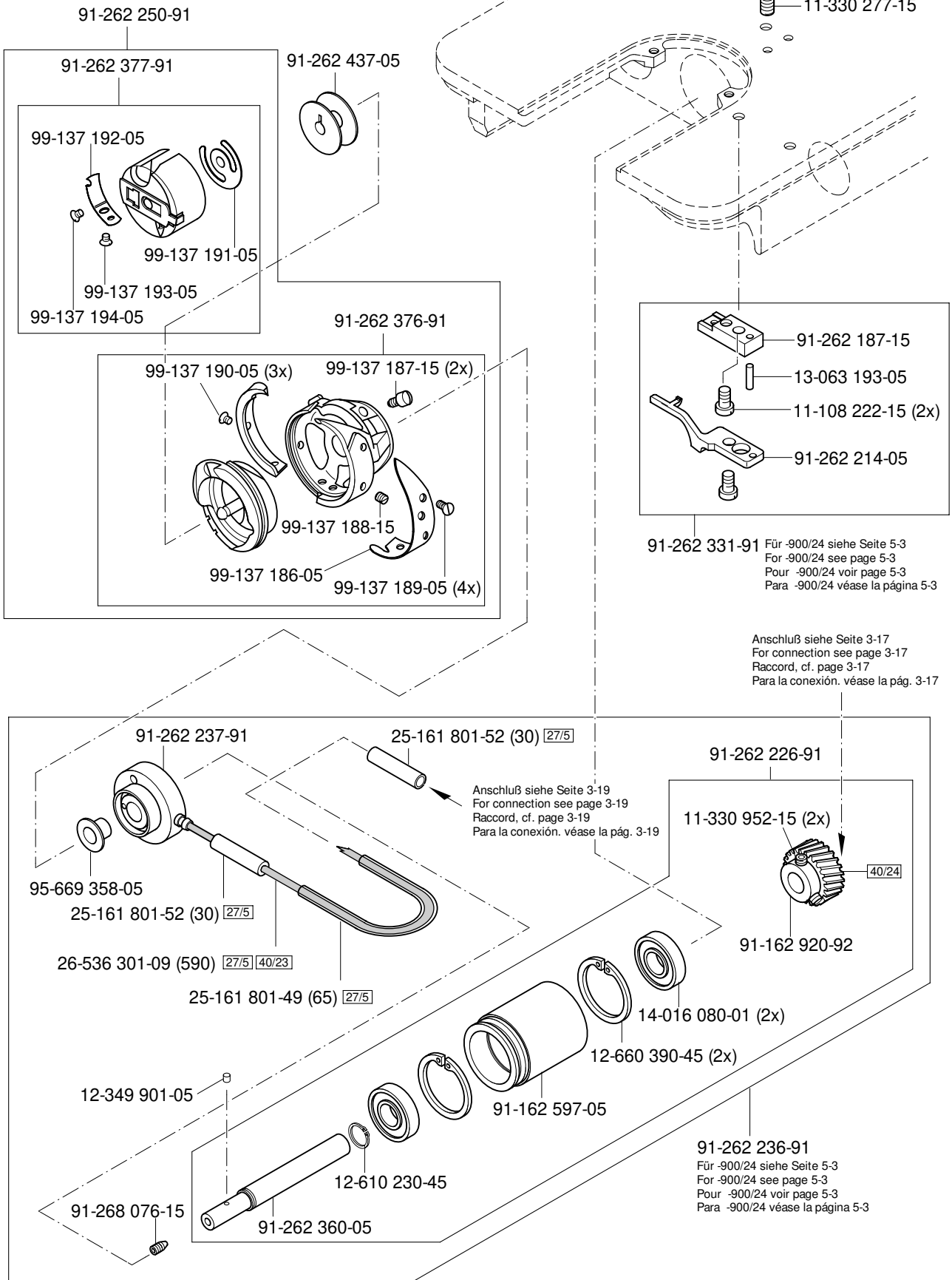
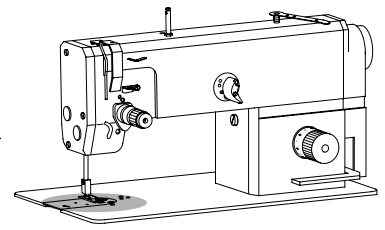

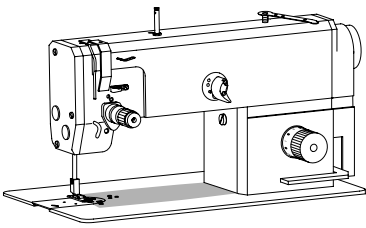

Grundplattenteile
 Bedplate parts
 Pièces du plateau fondamental
 Piezas del cárter

PFAFF 1051
 PFAFF 1053
 PFAFF 1181
 PFAFF 1183

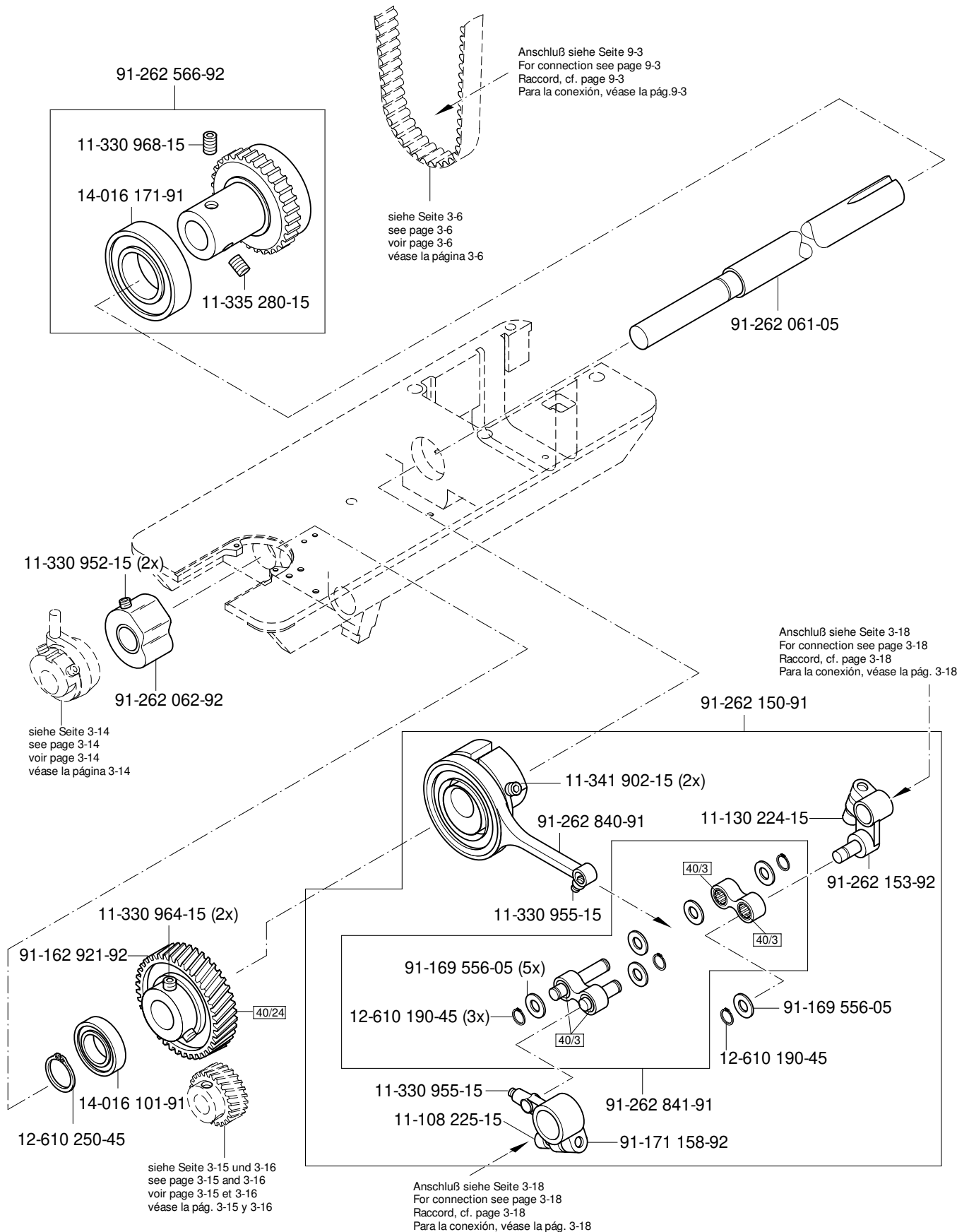

3.04

Grundplattenteile
 Bedplate parts
 Pièces du plateau fondamental
 Piezas del cárter

PFAFF 1051
 PFAFF 1053
 PFAFF 1181
 PFAFF 1183

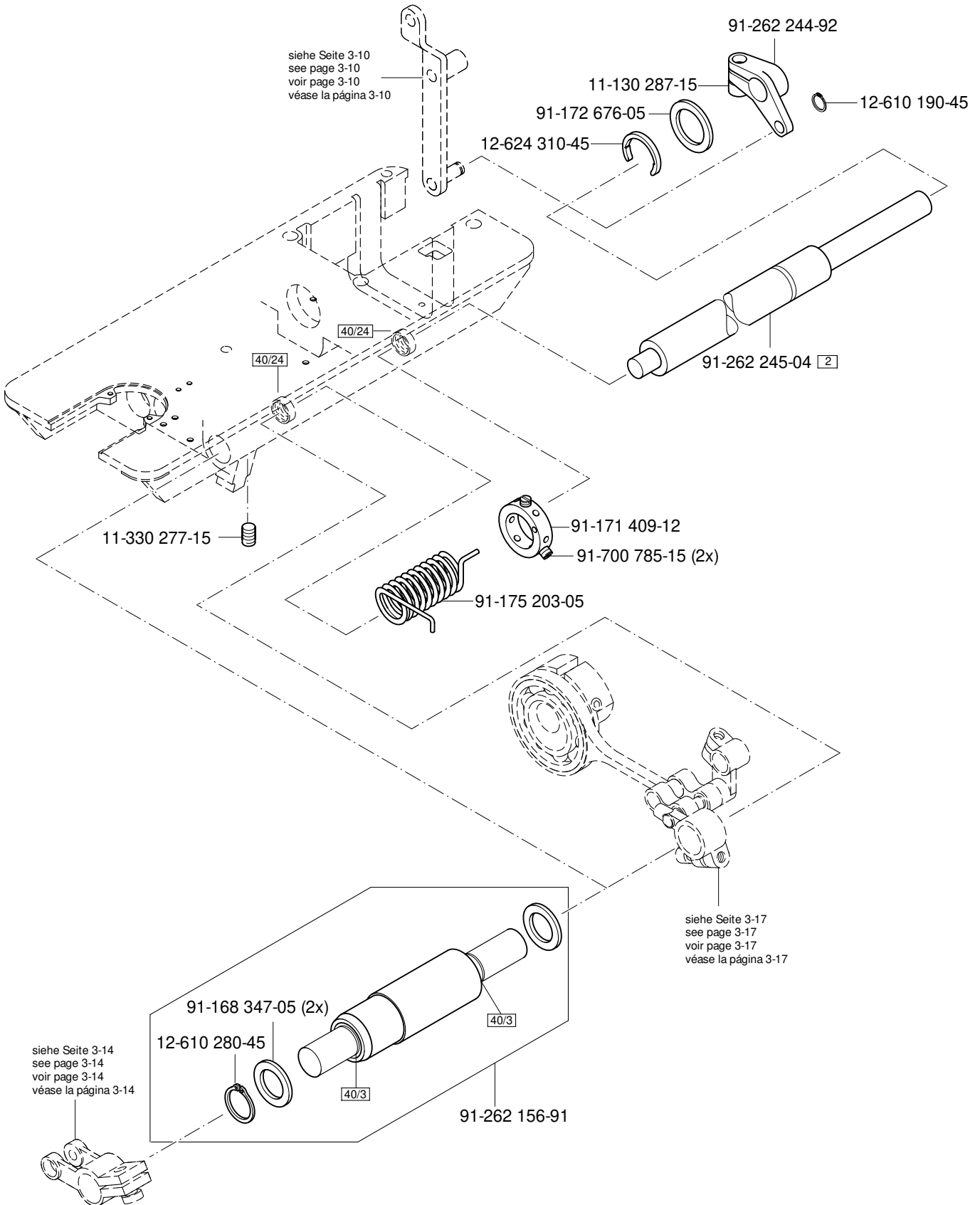
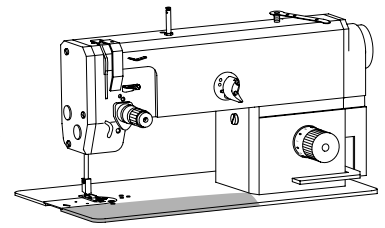

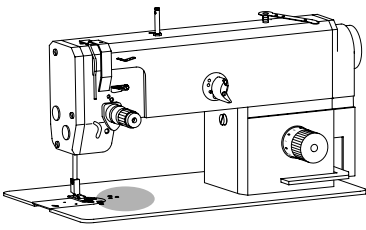

Grundplattenteile
 Bedplate parts
 Pièces du plateau fondamental
 Piezas del cárter

PFAFF 1181
 PFAFF 1183

3.04

siehe Seite 3-4 und 3-5
 see page 3-4 and 3-5
 voir page 3-4 et 3-5
 véase la página 3-4 y 3-5

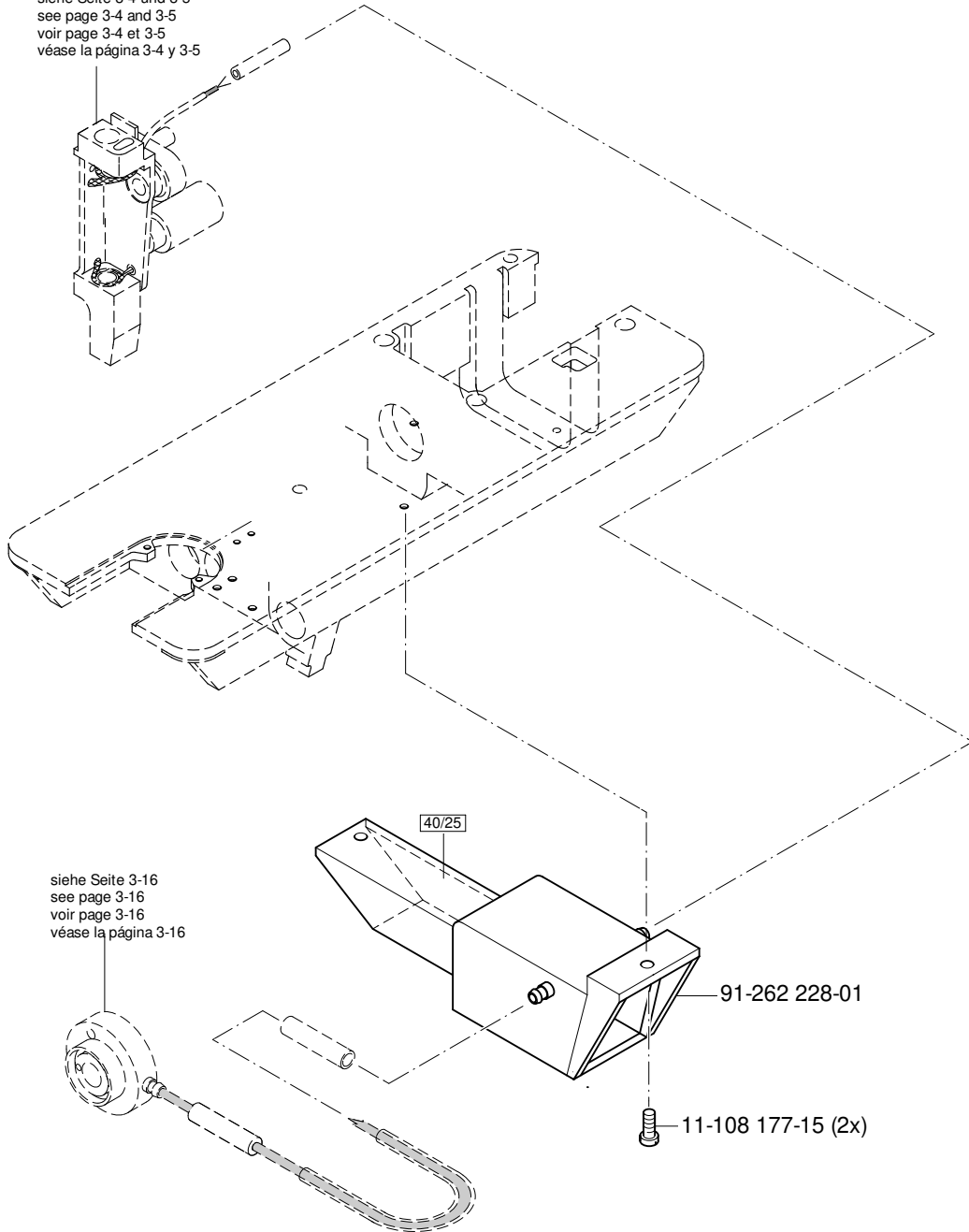

siehe Seite 3-16
 see page 3-16
 voir page 3-16
 véase la página 3-16

3.04

Grundplattenteile
 Bedplate parts
 Pièces du plateau fondamental
 Piezas del cárter

PFAFF 1051
 PFAFF 1053
 PFAFF 1181
 PFAFF 1183

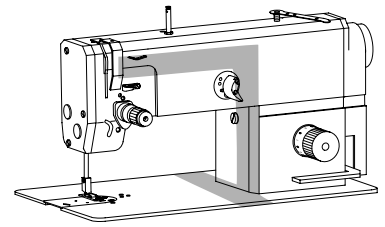

siehe Seite 3-7
 see page 3-7
 voir page 3-7
 véase la página 3-7

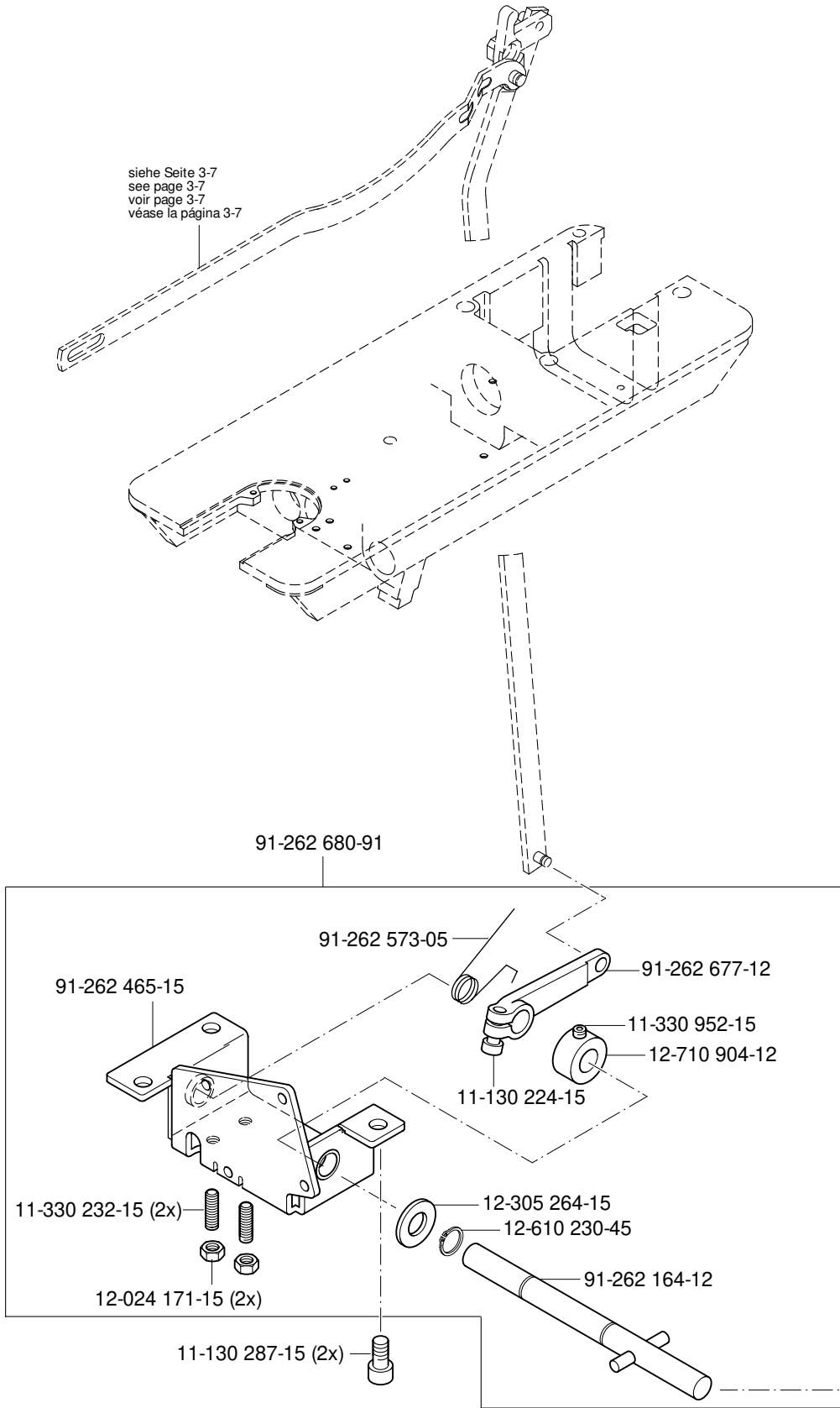

Anschluß siehe Seite 13-1
 For connection see page 13-1
 Raccord, cf. page 13-1
 Para la conexión, véase la pág. 13-1

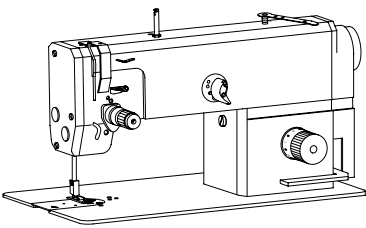

Kanten-Beschneideinrichtung (-731/01)
 Edge trimmer (-731/01)
 Couteau (-731/01)
 Recortador (-731/01)

PFAFF 1051
 PFAFF 1053
 PFAFF 1181
 PFAFF 1183

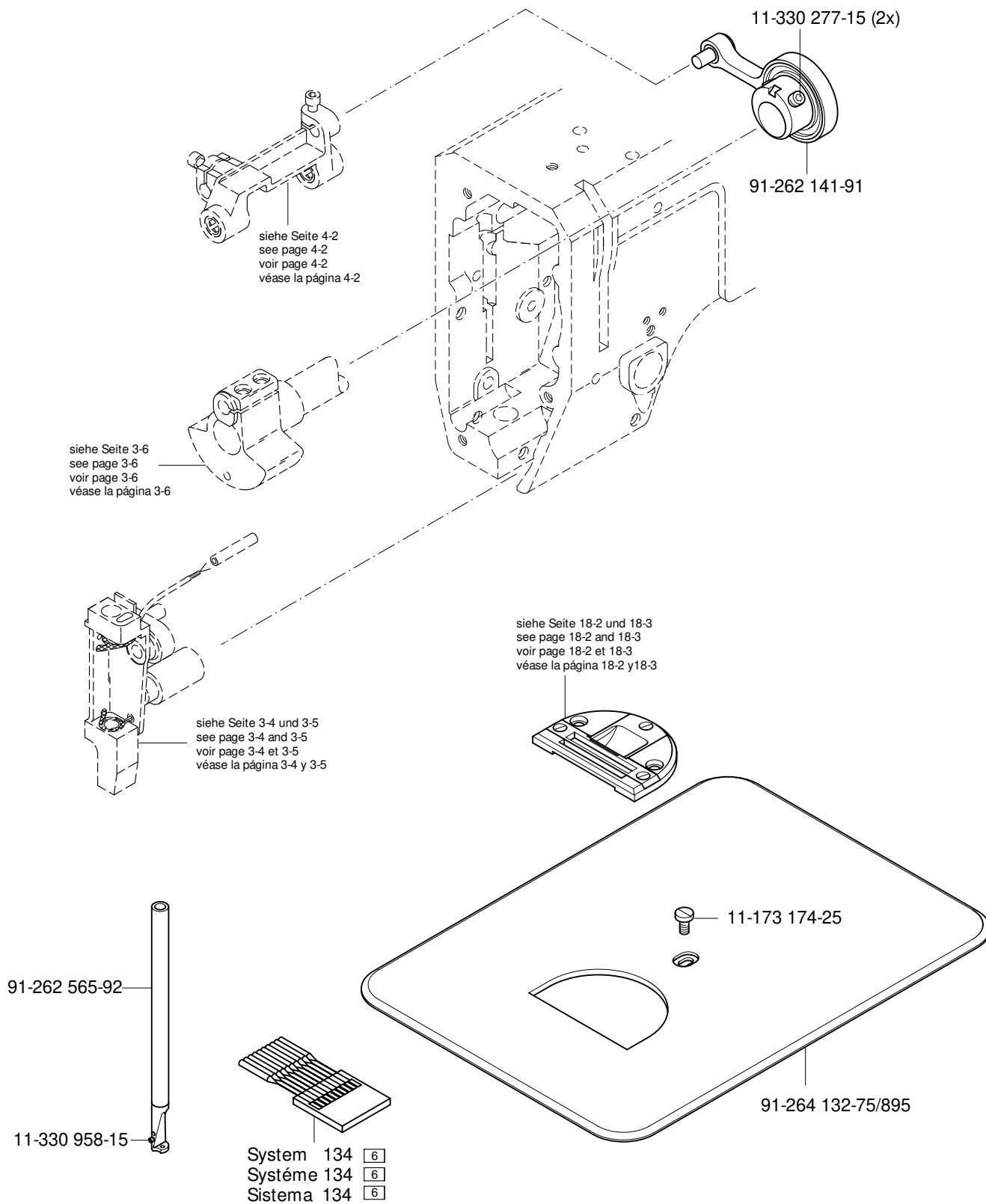

Kanten-Beschneideinrichtung (-731/01)
 Edge trimmer (-731/01)
 Couteau (-731/01)
 Recortador (-731/01)

PFAFF 1051
 PFAFF 1053
 PFAFF 1181
 PFAFF 1183

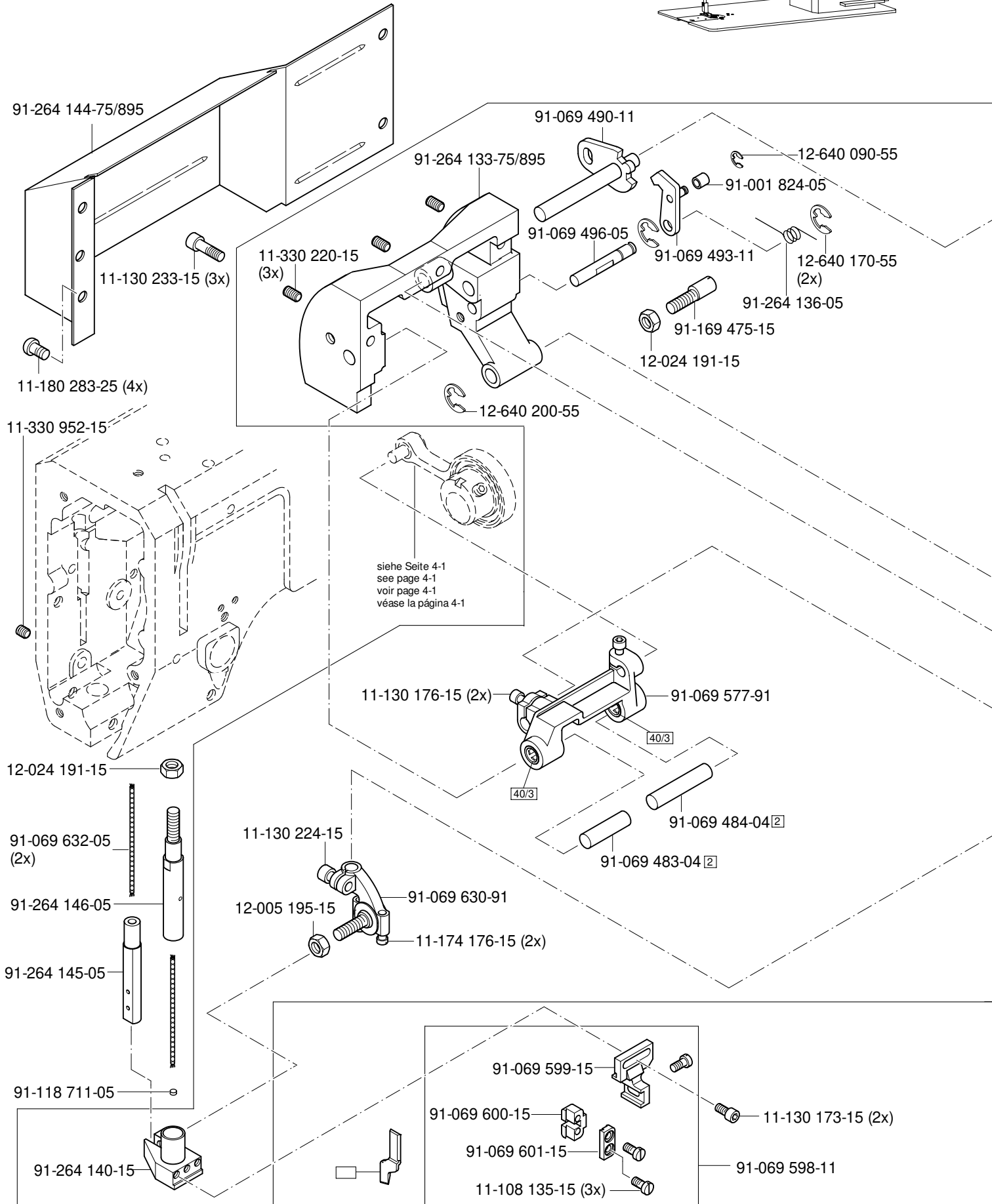
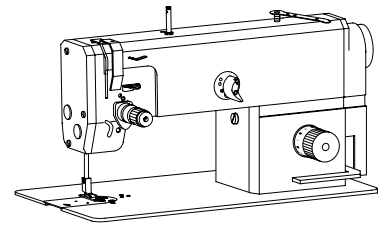

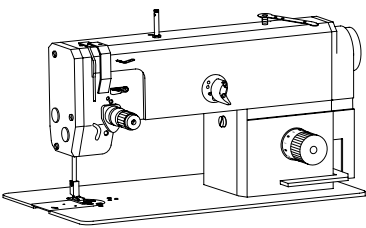

Kanten-Beschneideinrichtung (-731/01)
 Edge trimmer (-731/01)
 Couteau (-731/01)
 Recortador (-731/01)

PFAFF 1051
 PFAFF 1053
 PFAFF 1181
 PFAFF 1183

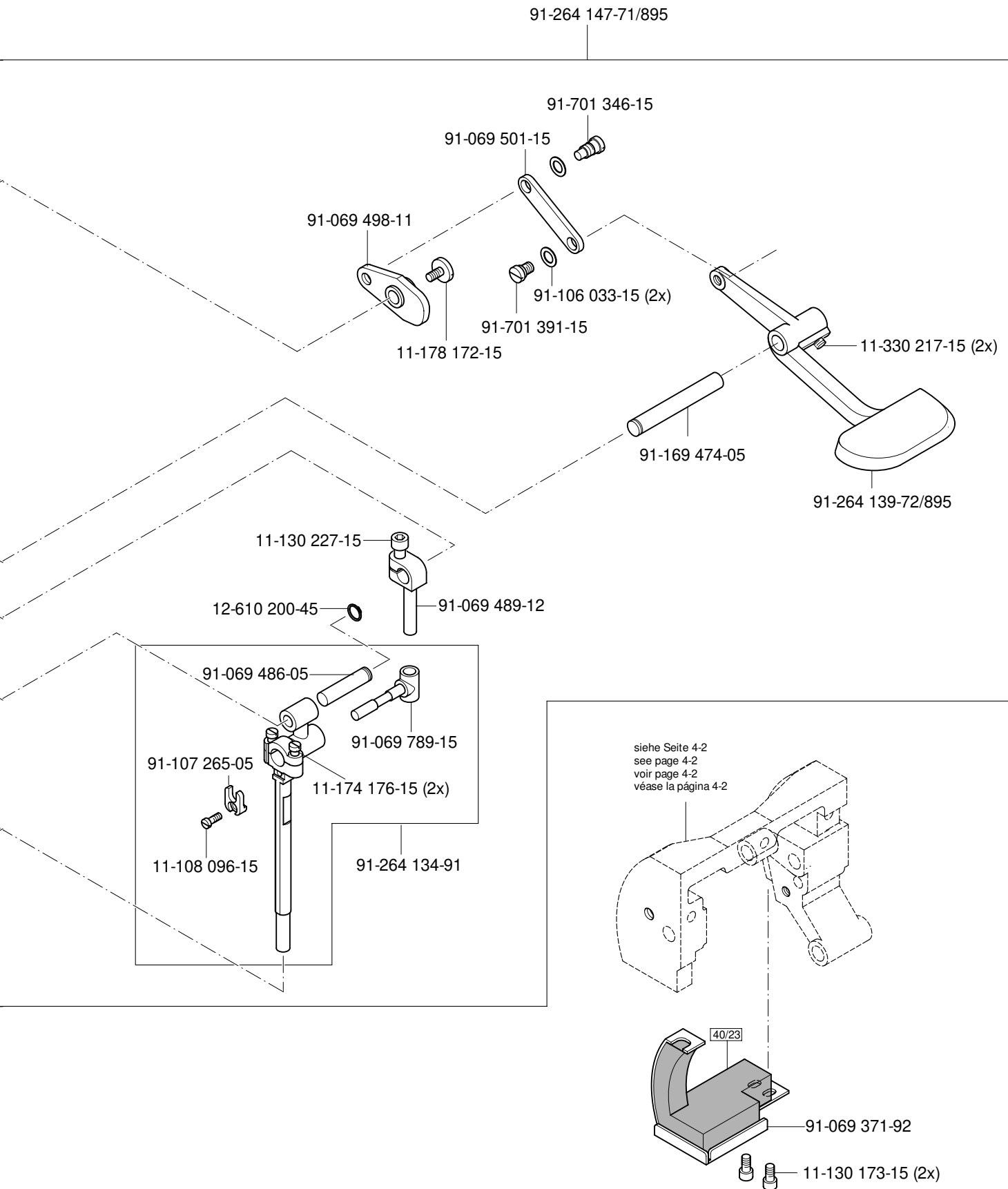

5

Fadenabschneid-Einrichtung (-900/24)
 Thread trimmer (-900/24)
 Coupe-fil (-900/24)
 Cortahilos (-900/24)

PFAFF 1051
 PFAFF 1053
 PFAFF 1181
 PFAFF 1183

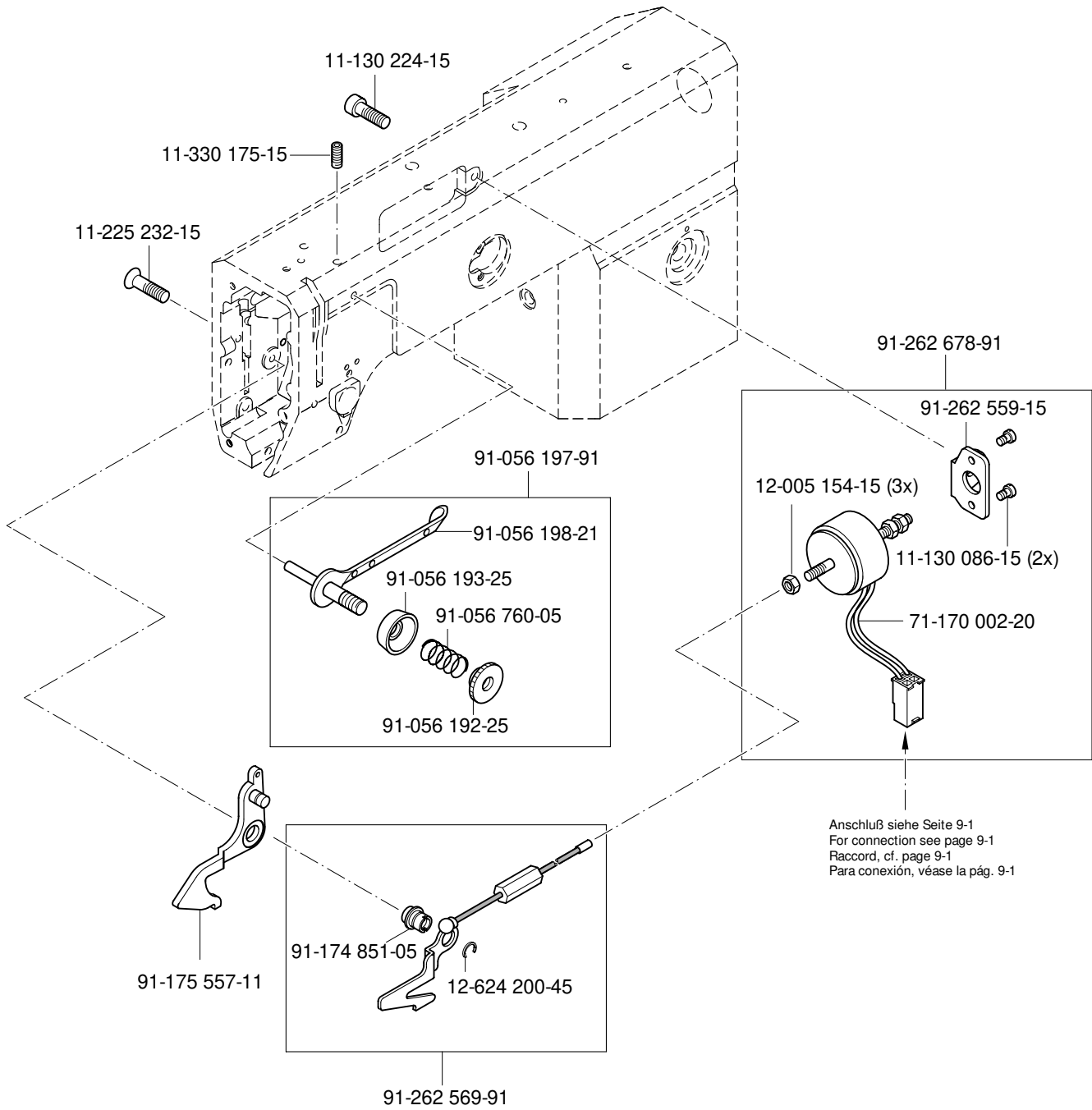
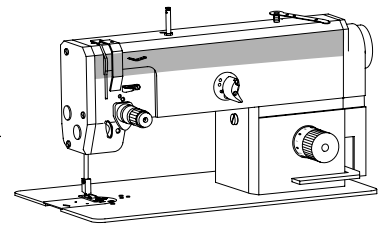

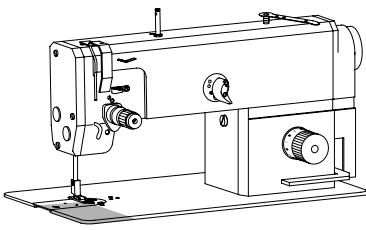

Fadenabschneid-Einrichtung (-900/24)
 Thread trimmer (-900/24)
 Coupe-fil (-900/24)
 Cortahilos (-900/24)

PFAFF 1051
 PFAFF 1053

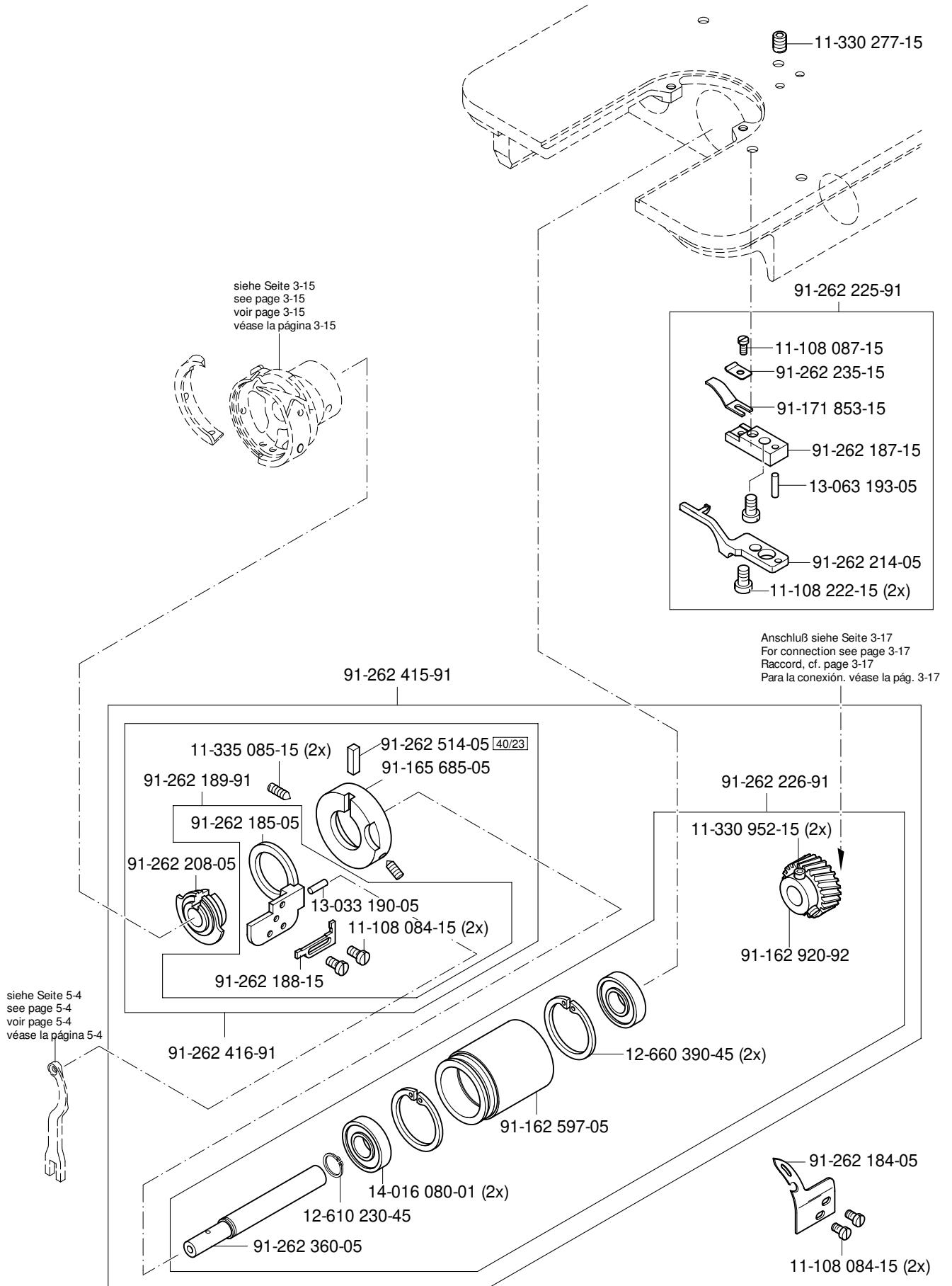

siehe Seite 3-15
 see page 3-15
 voir page 3-15
 véase la página 3-15

Anschluß siehe Seite 3-17
 For connection see page 3-17
 Raccord, cf. page 3-17
 Para la conexión. véase la pág. 3-17

siehe Seite 5-4
 see page 5-4
 voir page 5-4
 véase la página 5-4

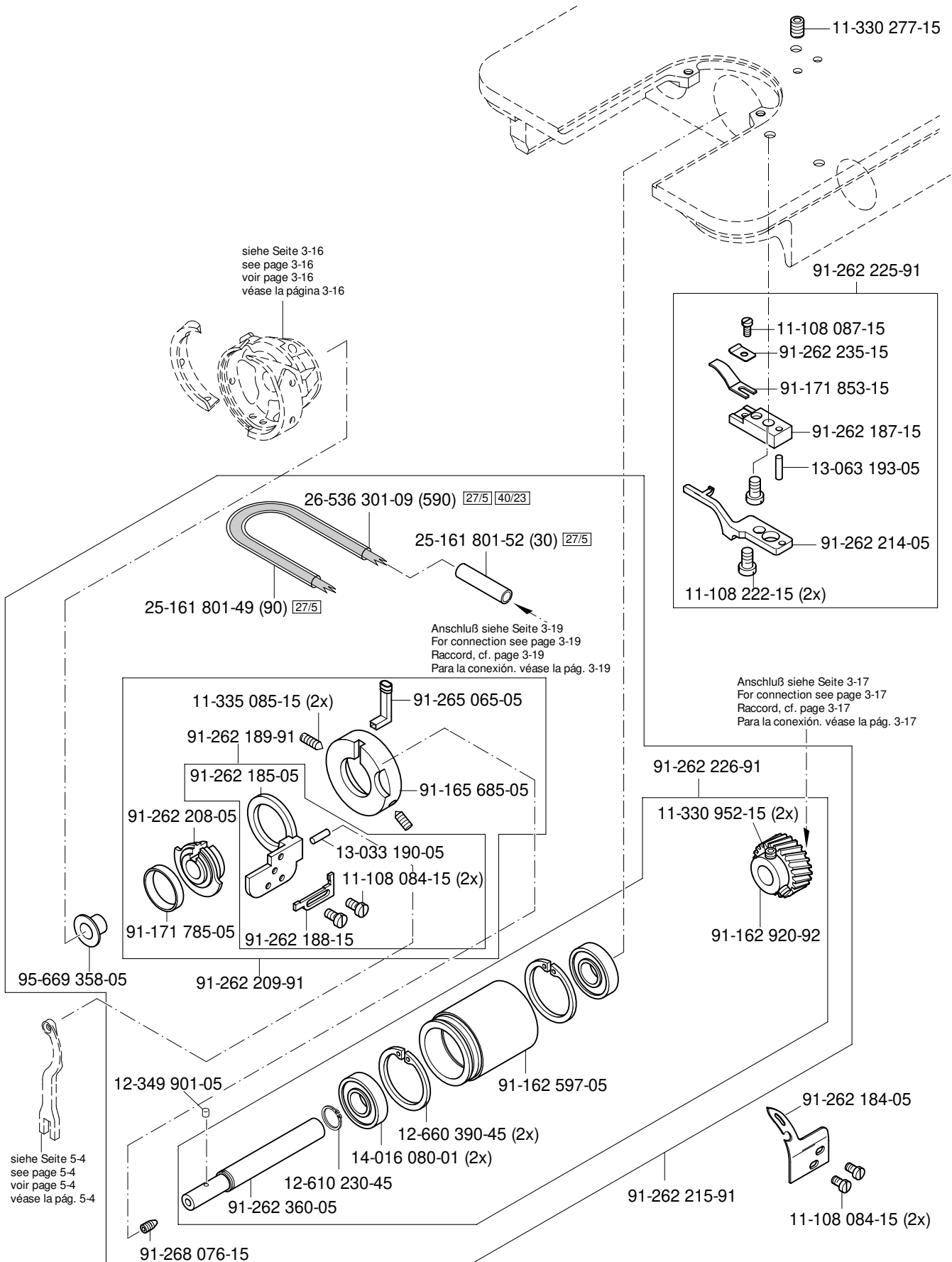
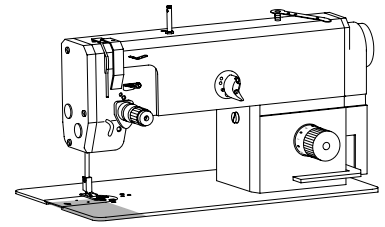

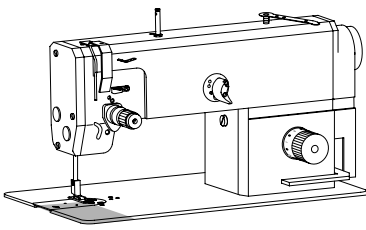

Fadenabschneid-Einrichtung (-900/24)
 Thread trimmer (-900/24)
 Coupe-fil (-900/24)
 Cortahilos (-900/24)

PFAFF 1051
 PFAFF 1053
 PFAFF 1181
 PFAFF 1183

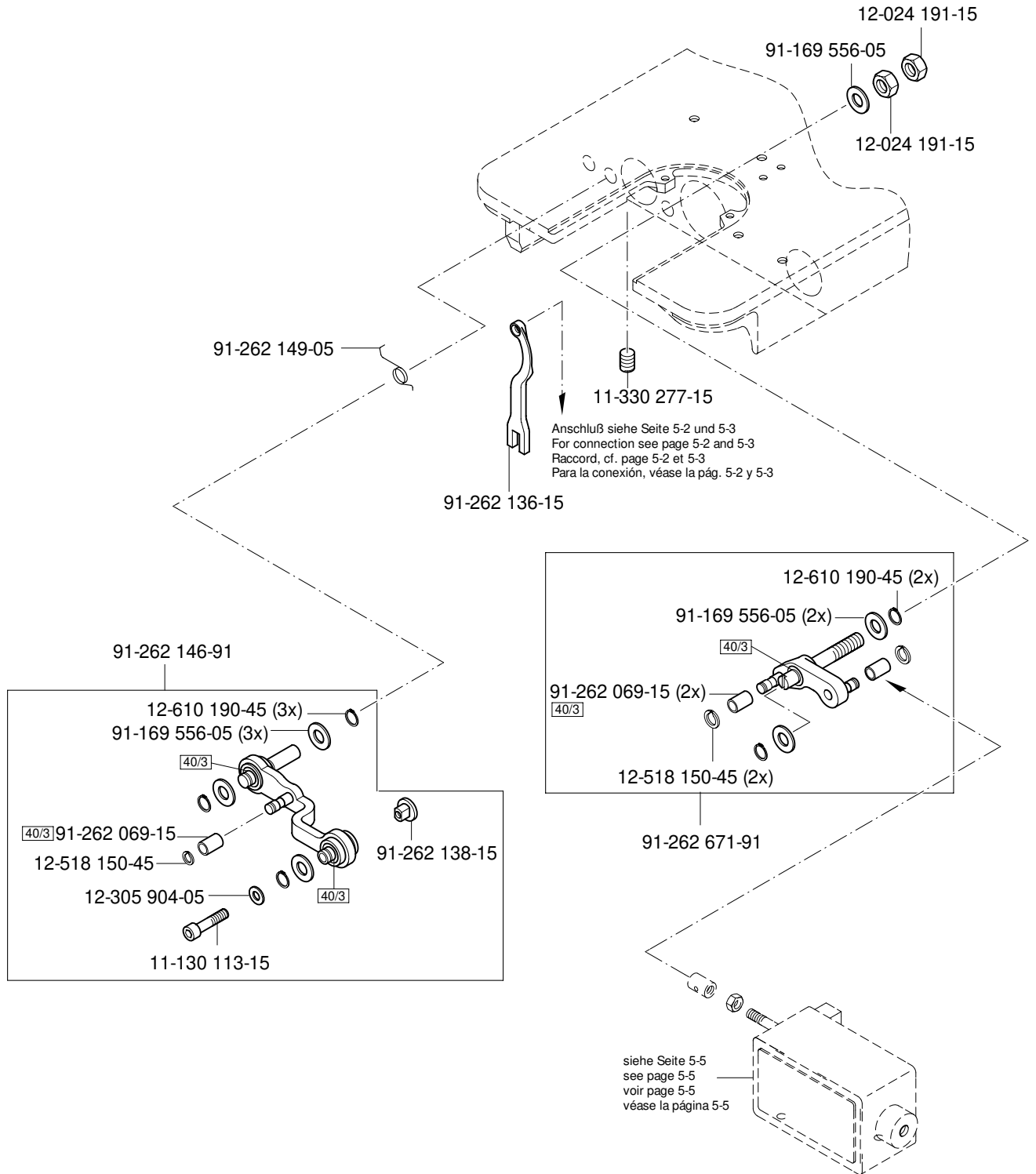

5

Fadenabschneid-Einrichtung (-900/24)
 Thread trimmer (-900/24)
 Coupe-fil (-900/24)
 Cortahilos (-900/24)

PFAFF 1051
 PFAFF 1053
 PFAFF 1181
 PFAFF 1183

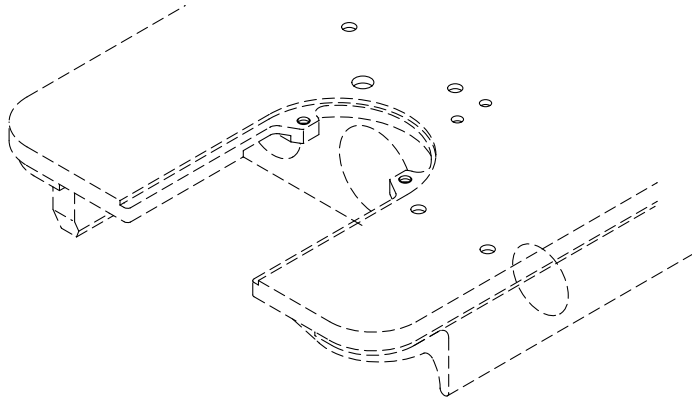
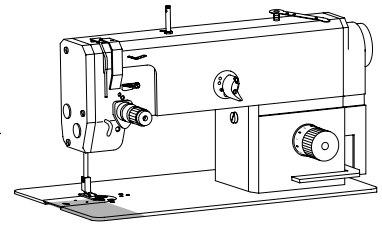

siehe Seite 5-4
 see page 5-4
 voir page 5-4
 véase la página 5-4

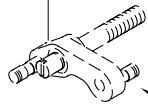

91-262 143-05

Anschluß siehe Seite 9-1
 For connection see page 9-1
 Raccord, cf. page 9-1
 Para la conexión, véase la pág. 9-1

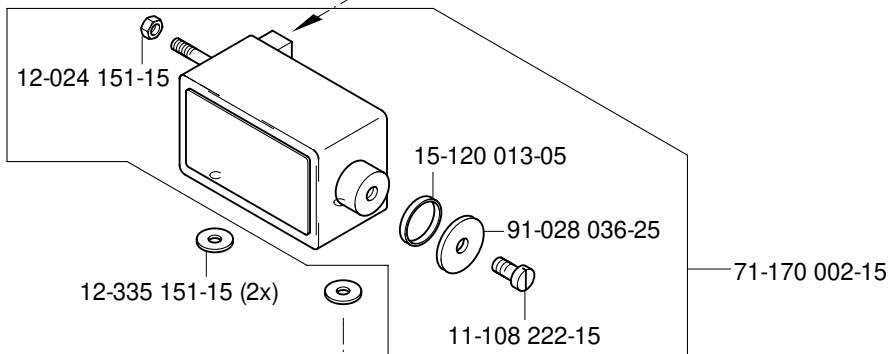

12-024 151-15

15-120 013-05

91-028 036-25

71-170 002-15

12-335 151-15 (2x)

11-108 222-15

siehe Seite 3-1
 see page 3-1
 voir page 3-1
 véase la página 3-1

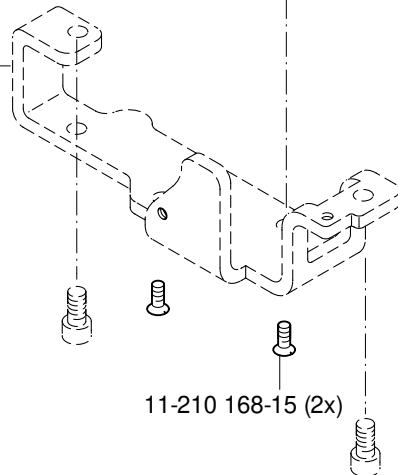

11-210 168-15 (2x)

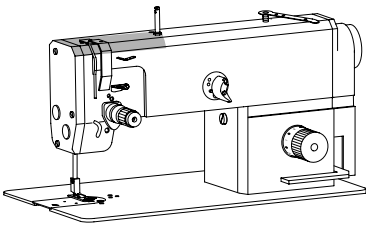

Fadenabstreif-Einrichtung (-909/04)
 Thread wiper (-909/04)
 Racleur de fil (-909/04)
 Retirahilos (-909/04)

PFAFF 1051-900/24
 PFAFF 1053-900/24
 PFAFF 1181-900/24
 PFAFF 1183-900/24

91-262 440-71/895

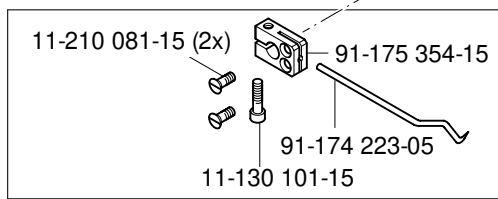
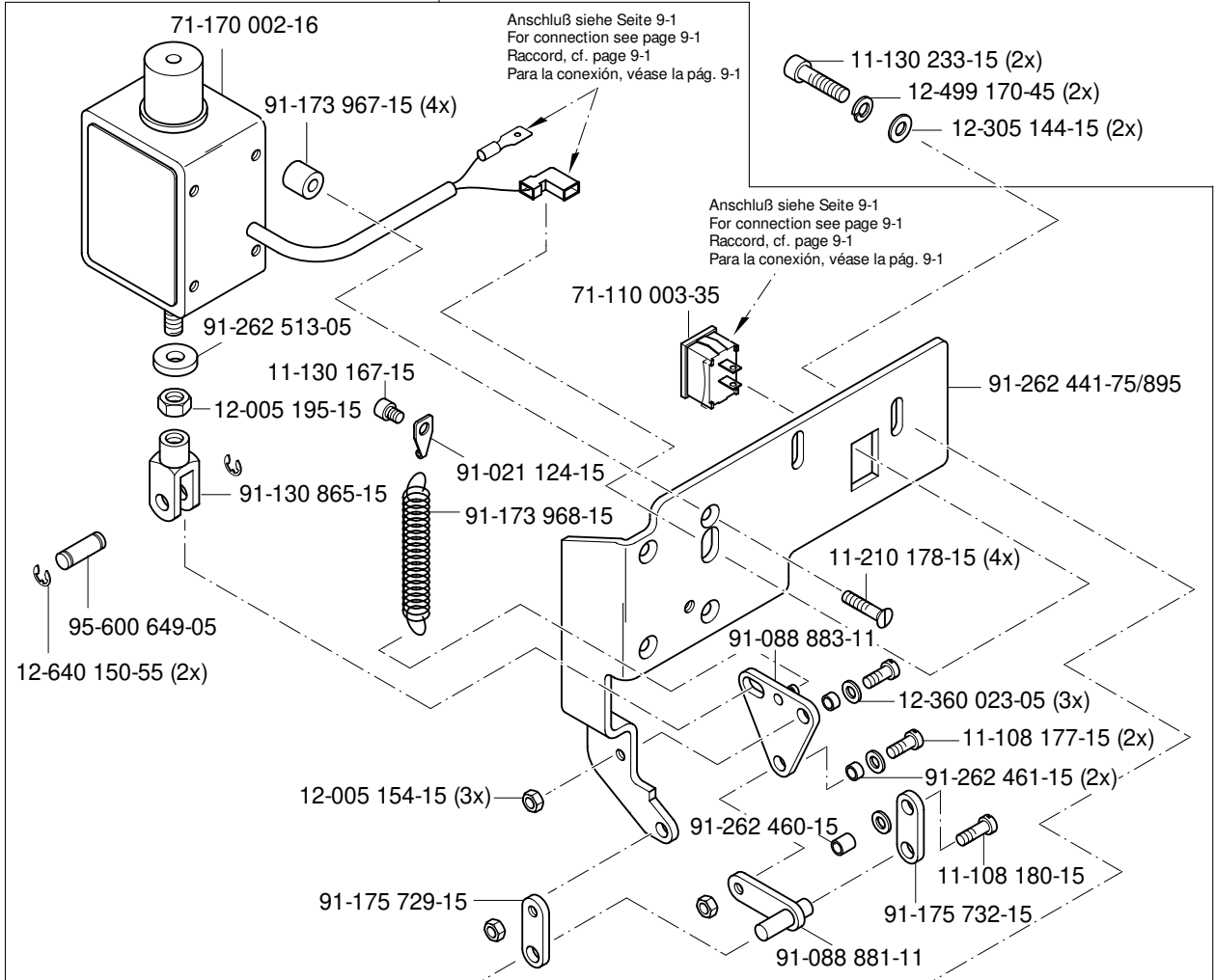

91-175 806-91

11-108 285-15 (5x)

91-262 442-75/895

11-317 950-15

91-175 265-12

siehe Seite 3-2
 see page 3-2
 voir page 3-2
 véase la página 3-2

7

Presserfuß-Automatik (-910/06)
 Automatic presser foot lifter (-910/06)
 Relève-pied automatique (-910/06)
 Alzaprensatelas (-910/06)

PFAFF 1051-900/24
 PFAFF 1053-900/24
 PFAFF 1181-900/24
 PFAFF 1183-900/24

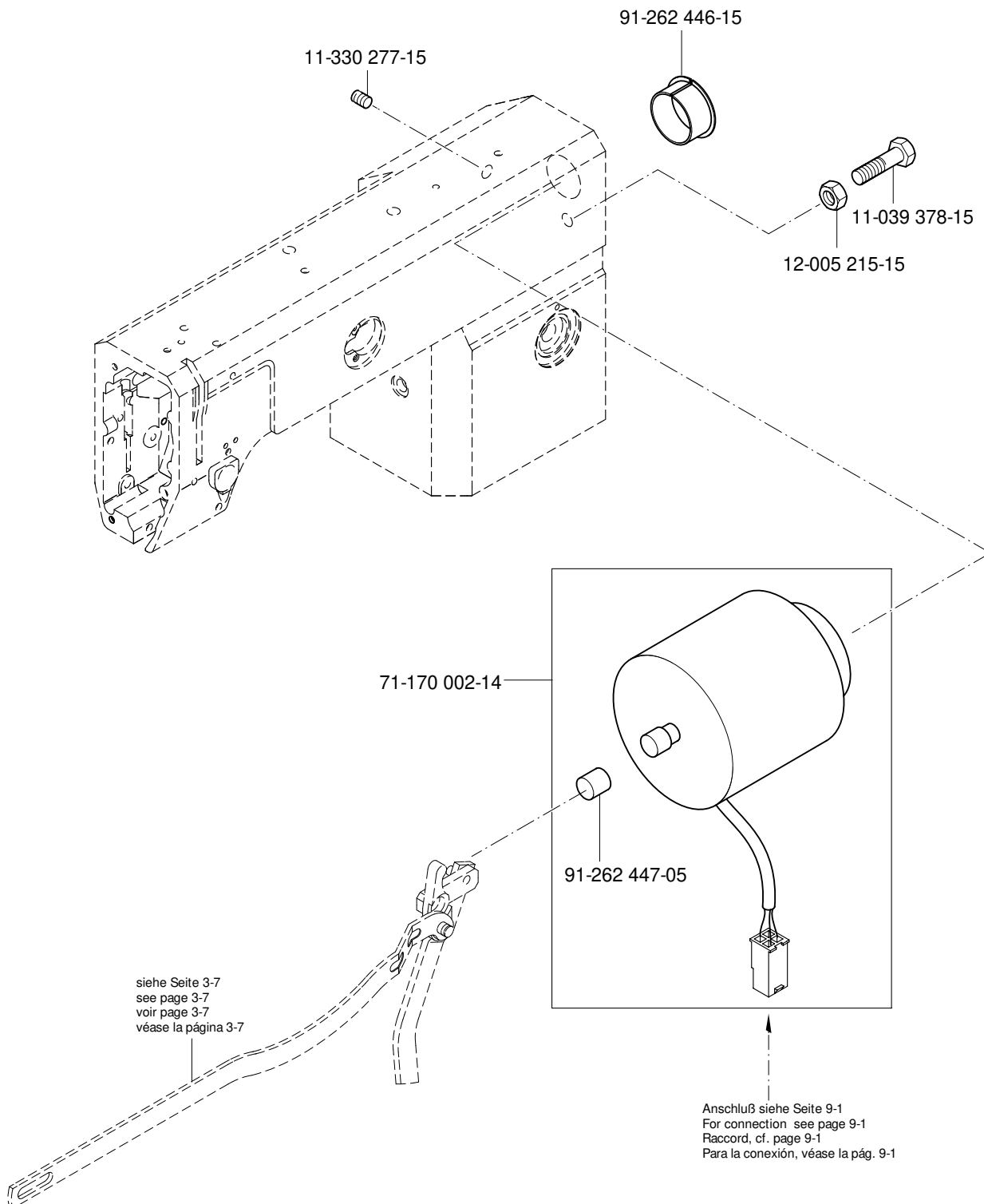
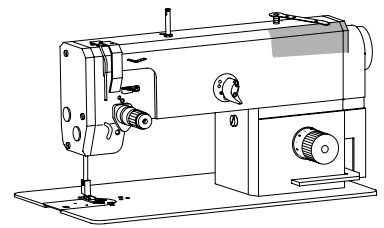

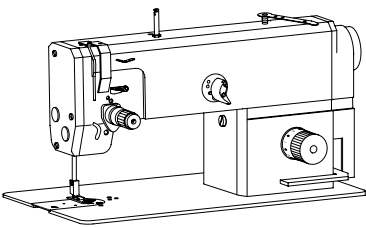

Verriegelungs-Einrichtung (-911/37)
 Backtacking mechanism (-911/37)
 Dispositif à points d'arrêt (-911/37)
 Rematador (-911/37)

PFAFF 1051-900/24
 PFAFF 1053-900/24
 PFAFF 1181-900/24
 PFAFF 1183-900/24

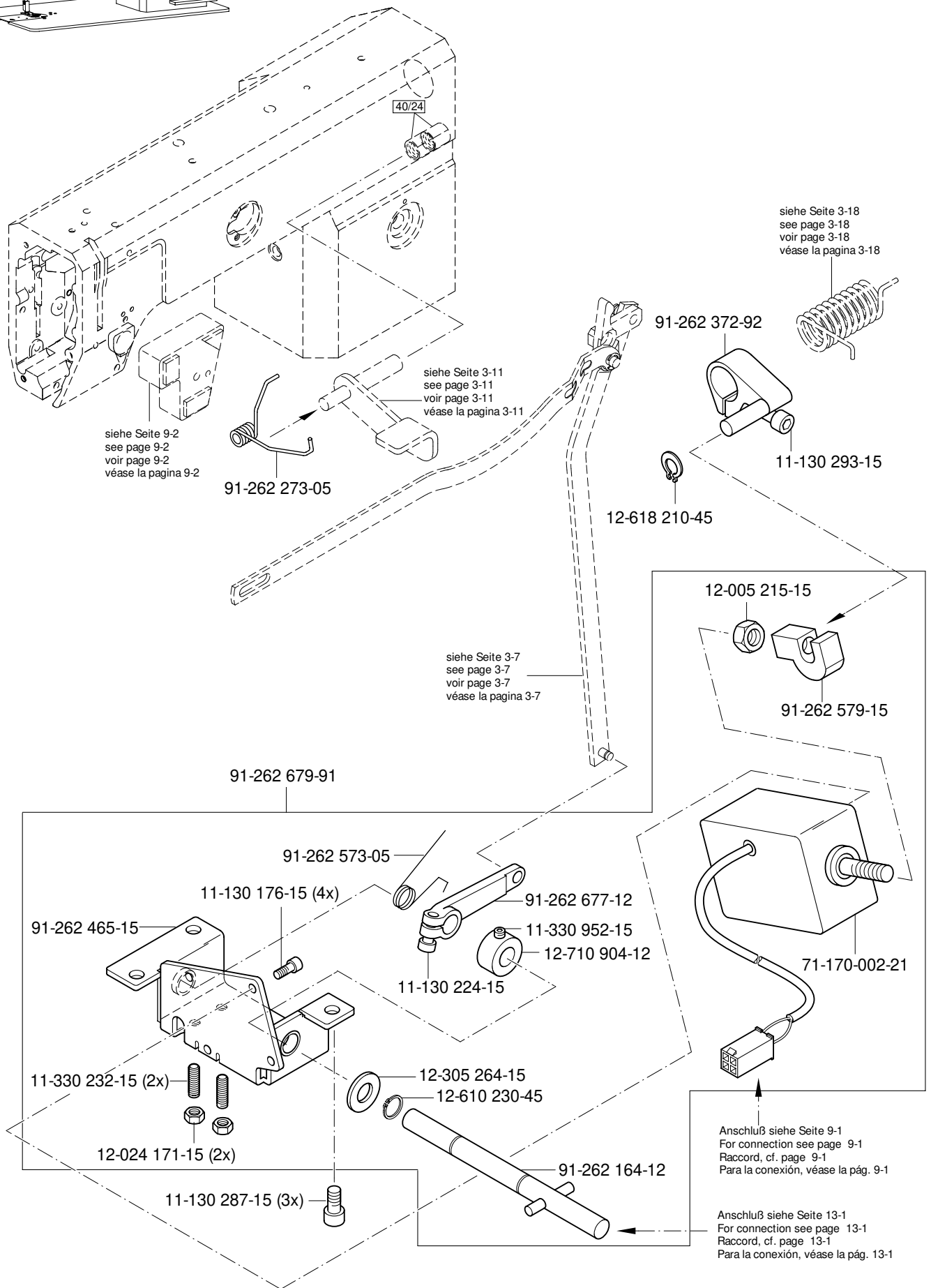

9.01

Kabelbaum zum Oberteil
 Cable tree to sewing head
 Faisceau de câbles vers la tête de machine
 Mazo de cables para el cabezal

PFAFF 1051-900/24
 PFAFF 1053-900/24
 PFAFF 1181-900/24
 PFAFF 1183-900/24

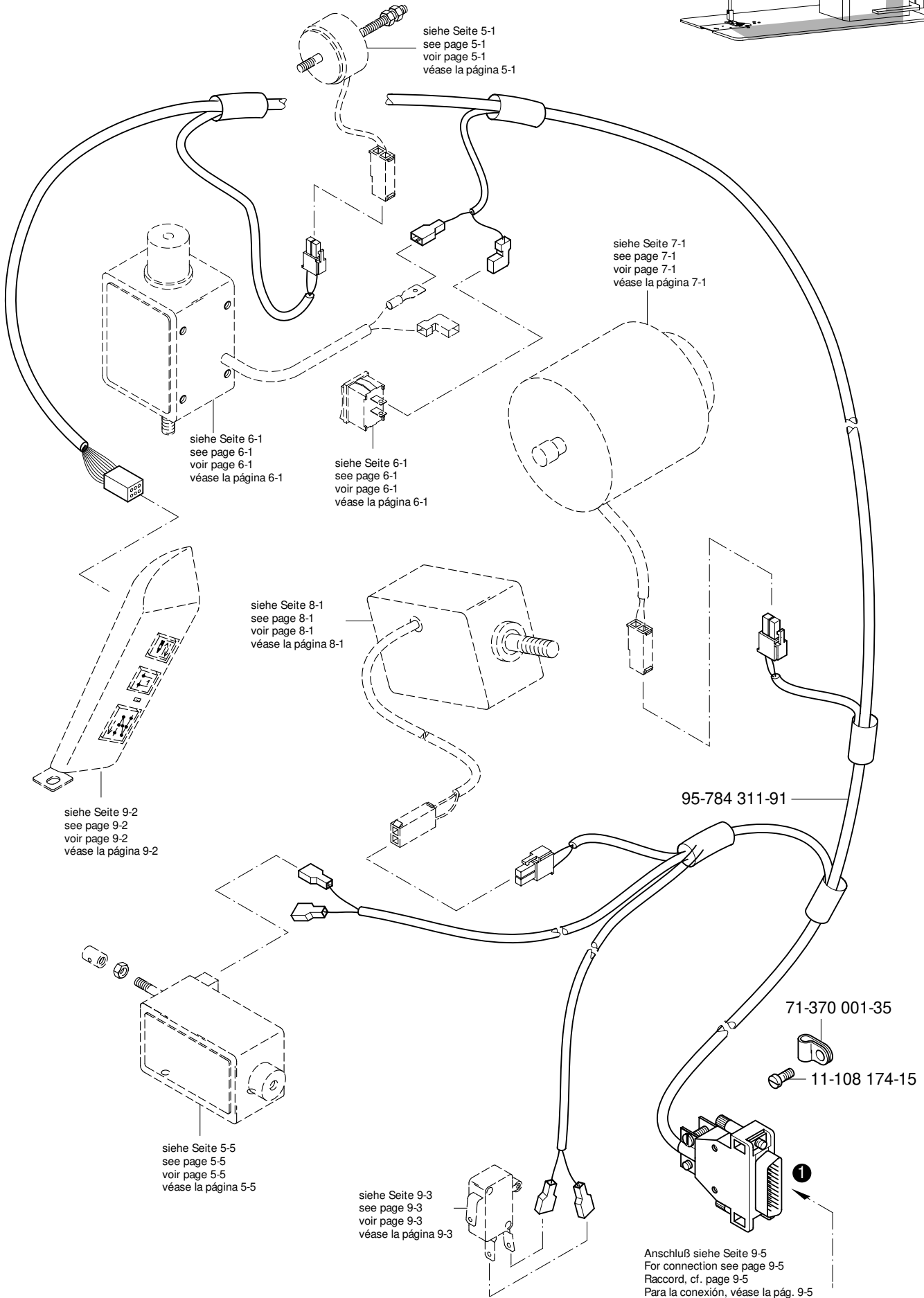
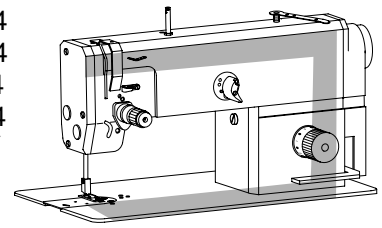

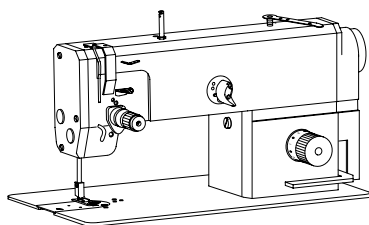

Tastenschalter
 Push-button
 Interrupteur à bouton-poussoir
 Interruptor pulsador

PFAFF 1051-911/37
 PFAFF 1053-911/37
 PFAFF 1181-911/37
 PFAFF 1183-911/37

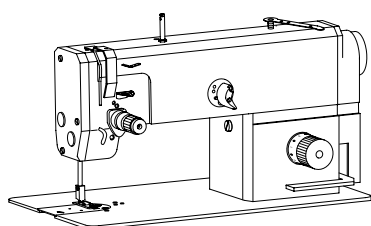
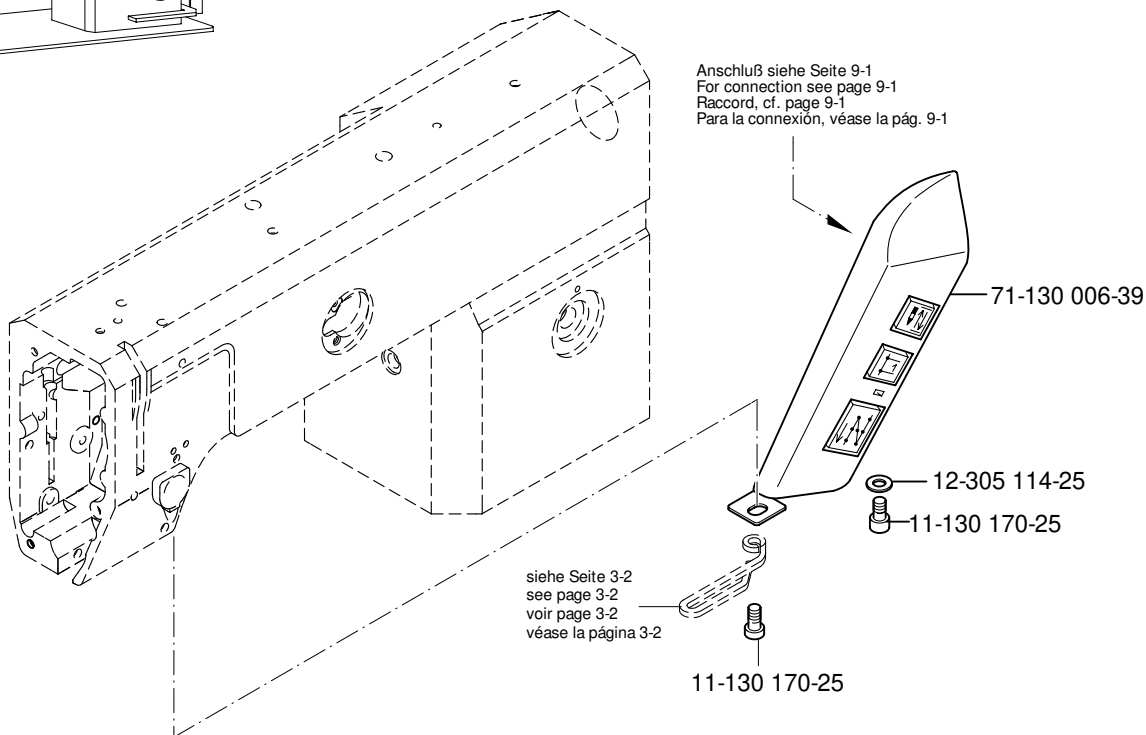

Bedienfeld
 Control panel
 Panneau de commande
 Panel de mandos

PFAFF 1051-900/24
 PFAFF 1053-900/24
 PFAFF 1181-900/24
 PFAFF 1183-900/24

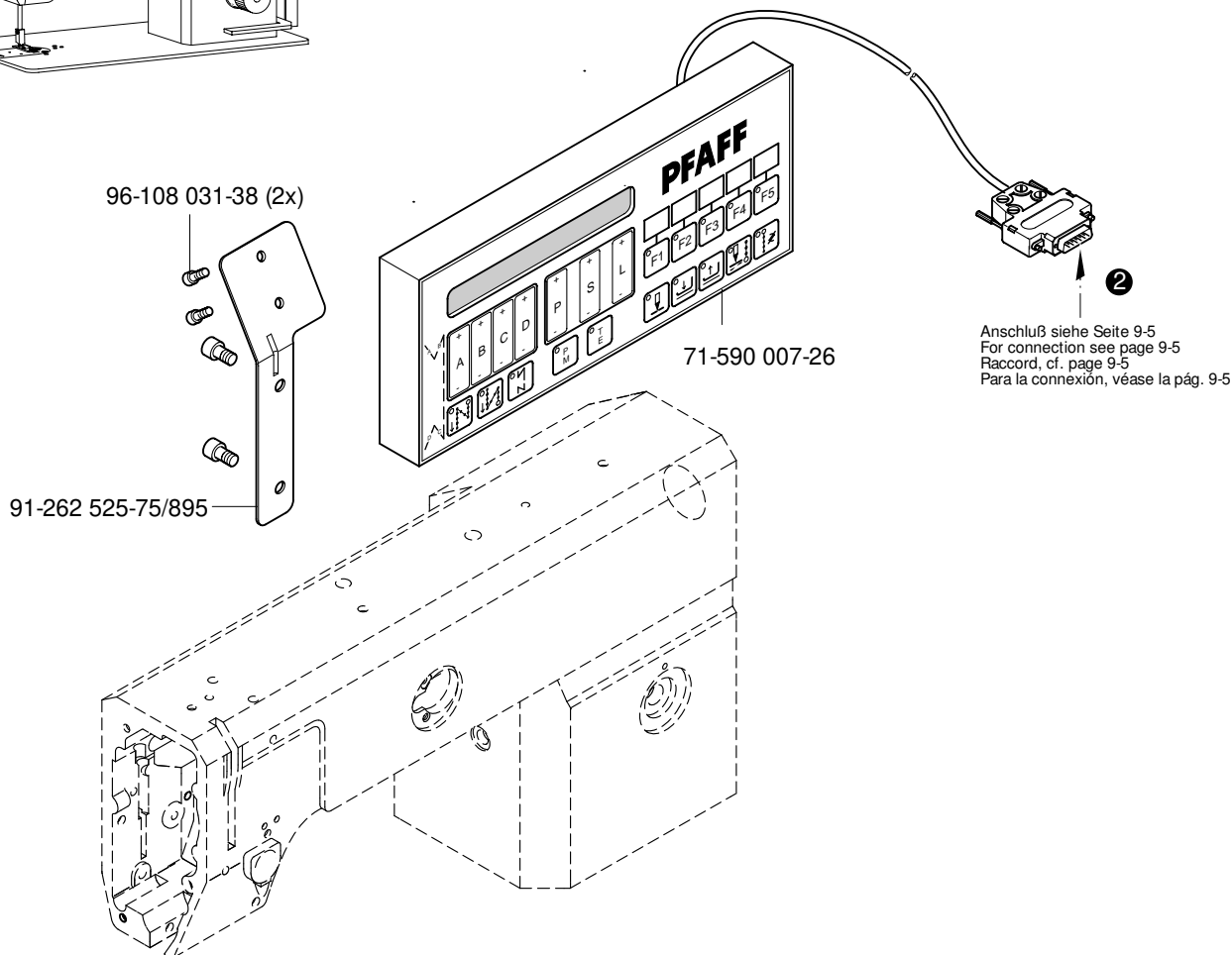

9.04

Einbaumotor
Built-in motor
Moteur incorporé
Motor incorporado

PFAFF 1051-900/24
PFAFF 1053-900/24
PFAFF 1181-900/24
PFAFF 1183-900/24

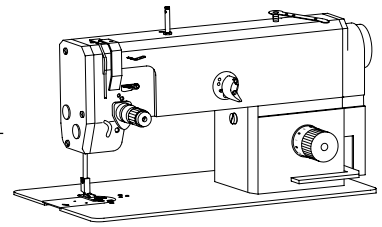

Use screw # 11-330 952-15 on top of screw # 11-335 223-15 and secure with locktite

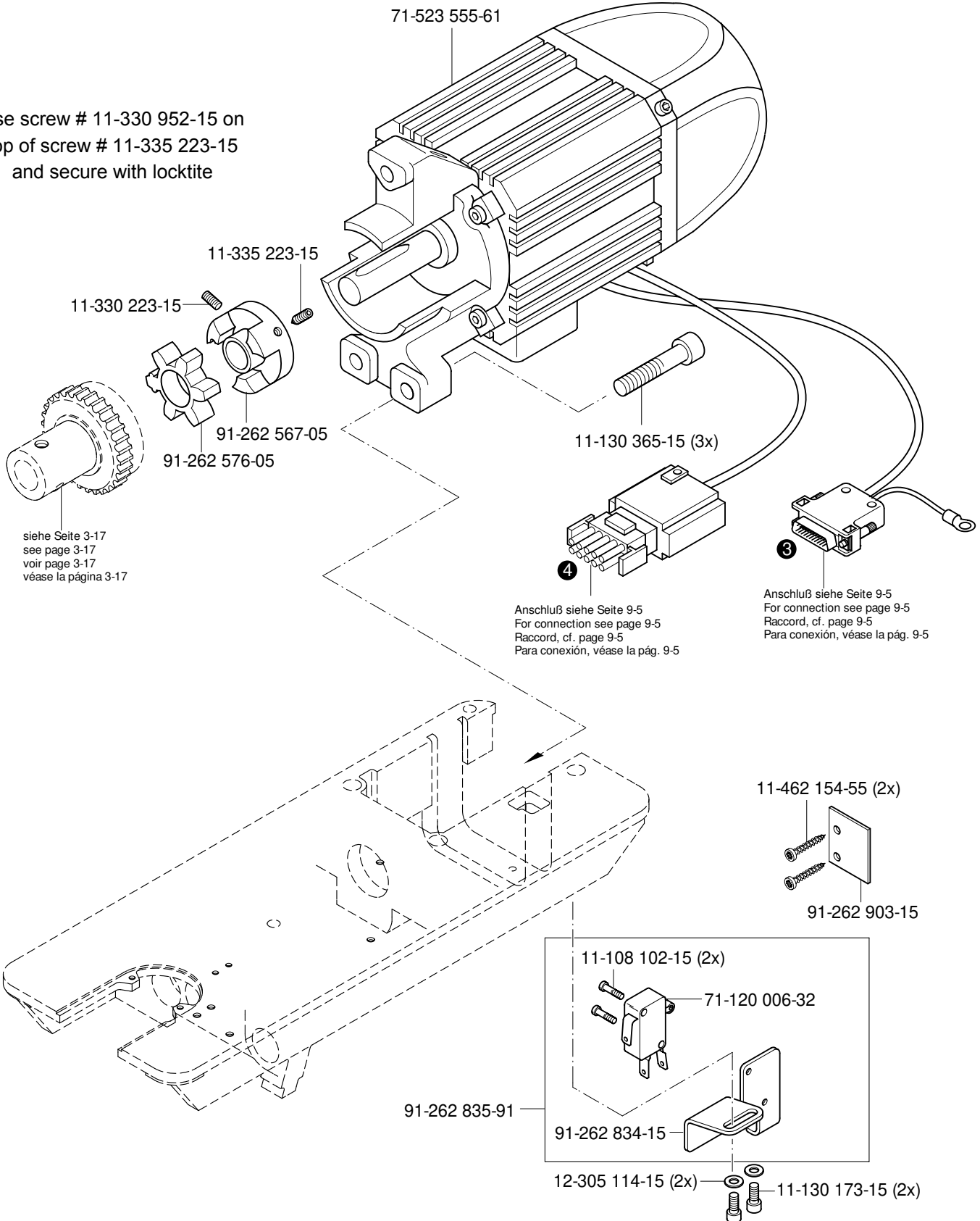

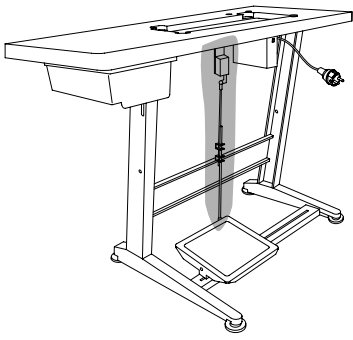

Sollwertgeber
Set-point generator
Codeur
Emisor del valor teórico

PFAFF 1051
PFAFF 1053
PFAFF 1181
PFAFF 1183

9.05

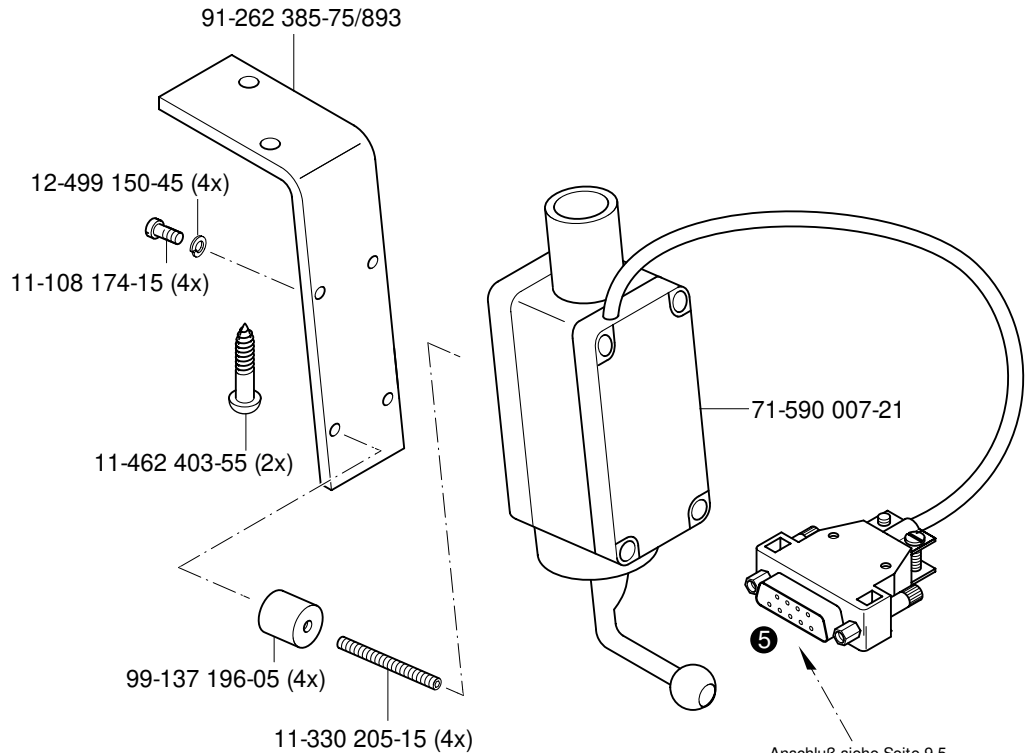

Anschluß siehe Seite 9-5
For connection see page 9-5
Raccordo, cf. page 9-5
Para la conexión, véase la pág. 9-5

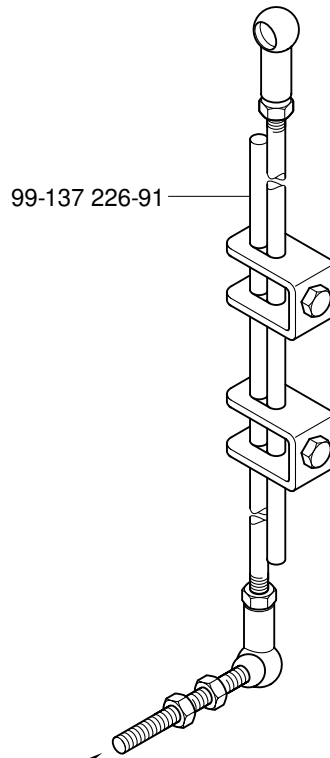

Zur Tretplatte
For the pedal
Pour la pédale
Para el pedal

9.06

Steuergerät
Control device
Boîte de commande
Caja de mandos

PFAFF 1051-900/24
PFAFF 1053-900/24
PFAFF 1181-900/24
PFAFF 1183-900/24

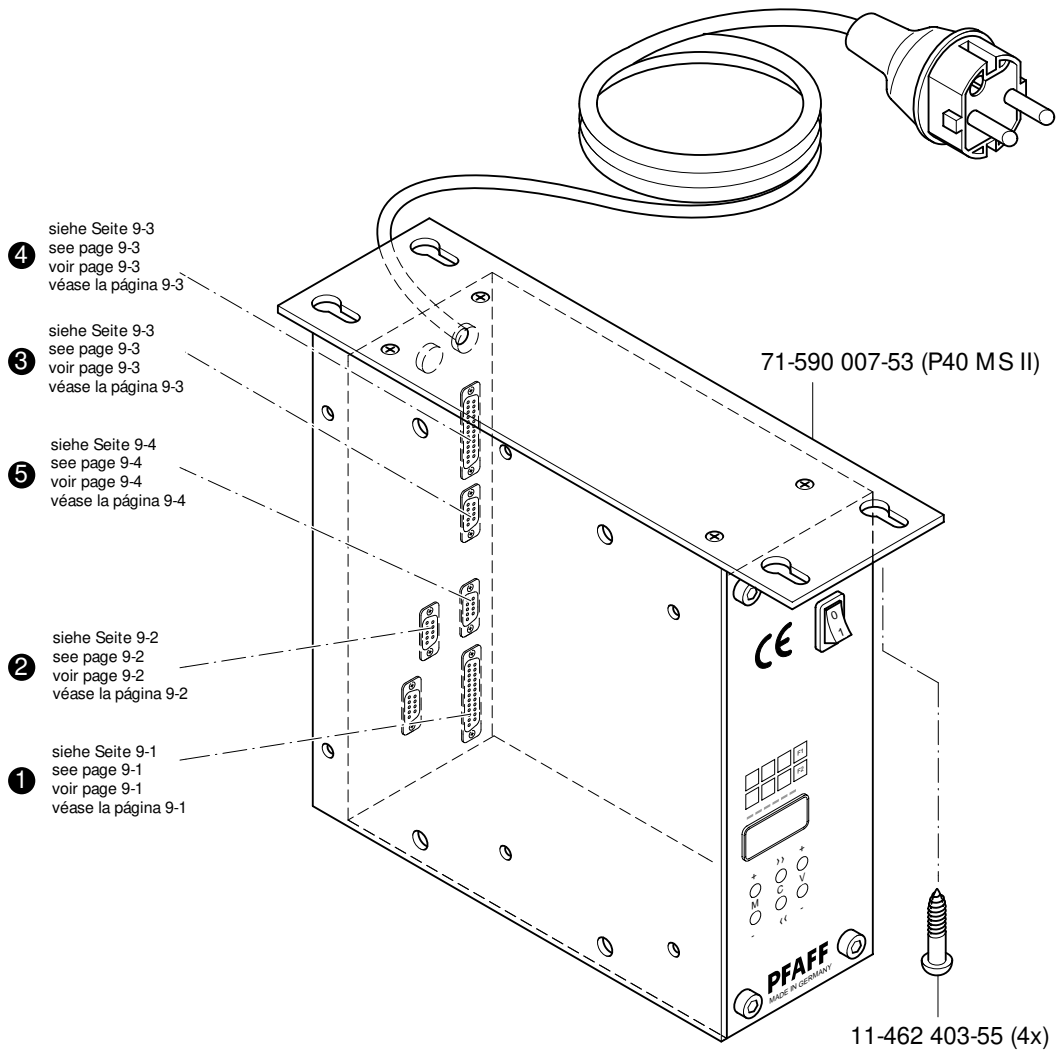
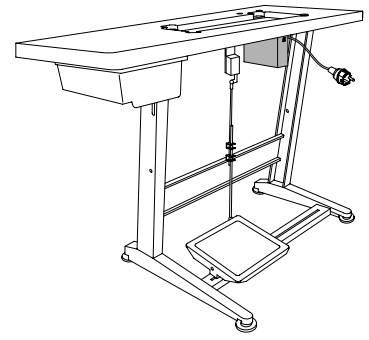

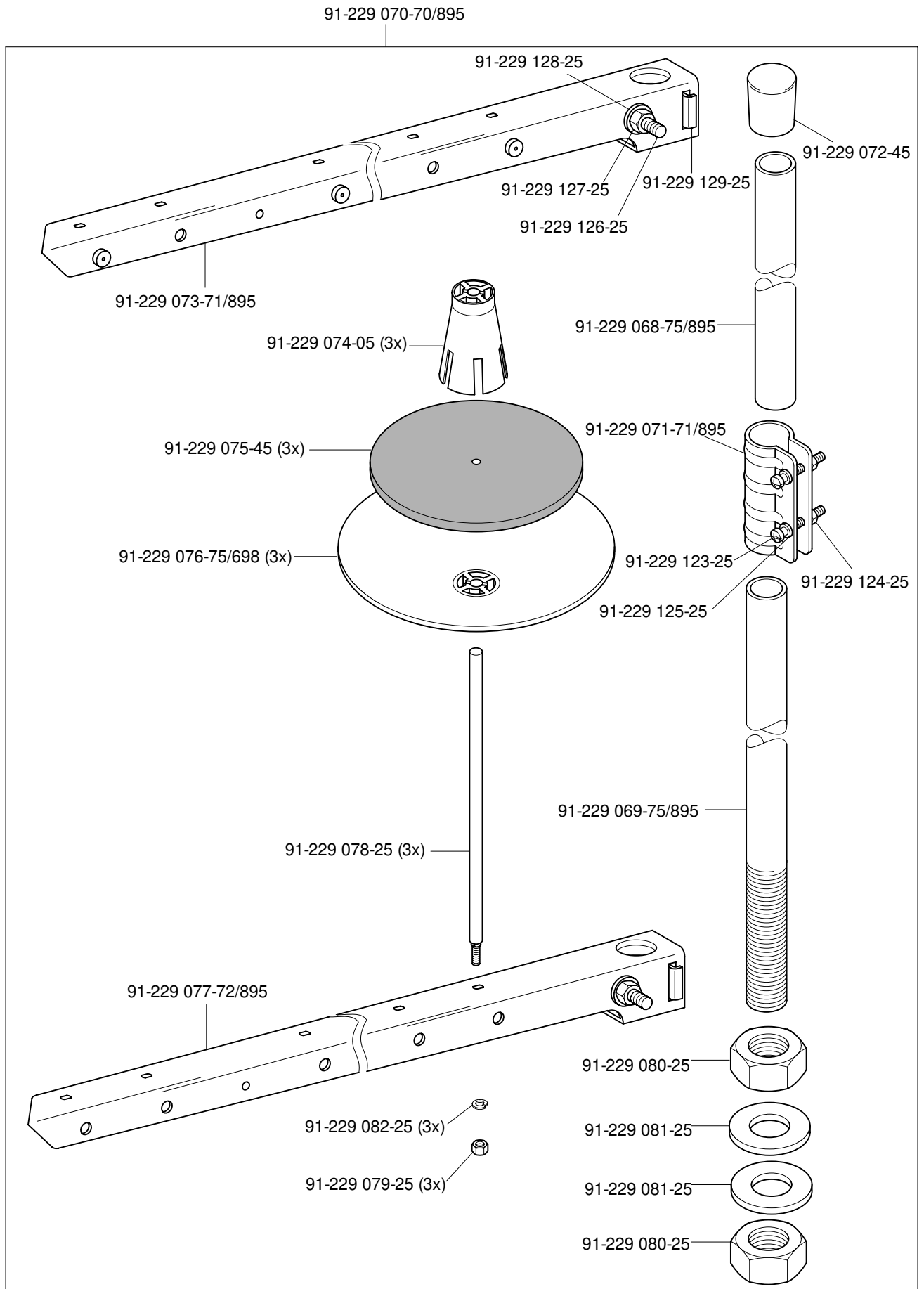

11

Einstellehren	PFAFF 1051
Adjustment gauges	PFAFF 1053
Calibres	PFAFF 1181
Calibres de ajuste	PFAFF 1183

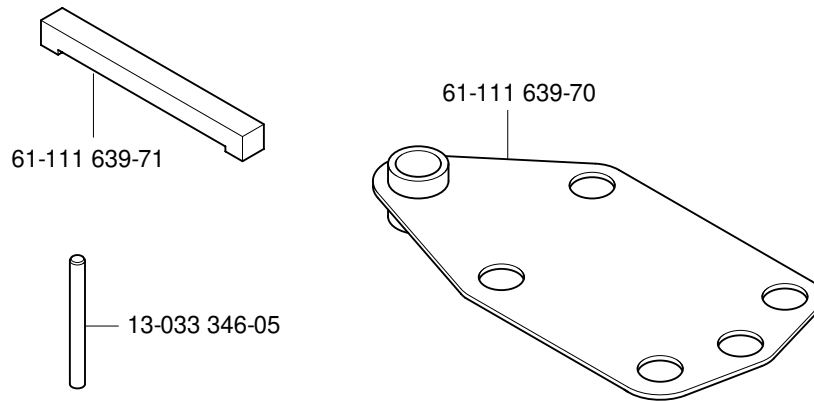

12

Teile zur Tischplatte	PFAFF 1051
Parts for table top	PFAFF 1053
Pièces du plateau	PFAFF 1181
Piezas para el tablero	PFAFF 1183

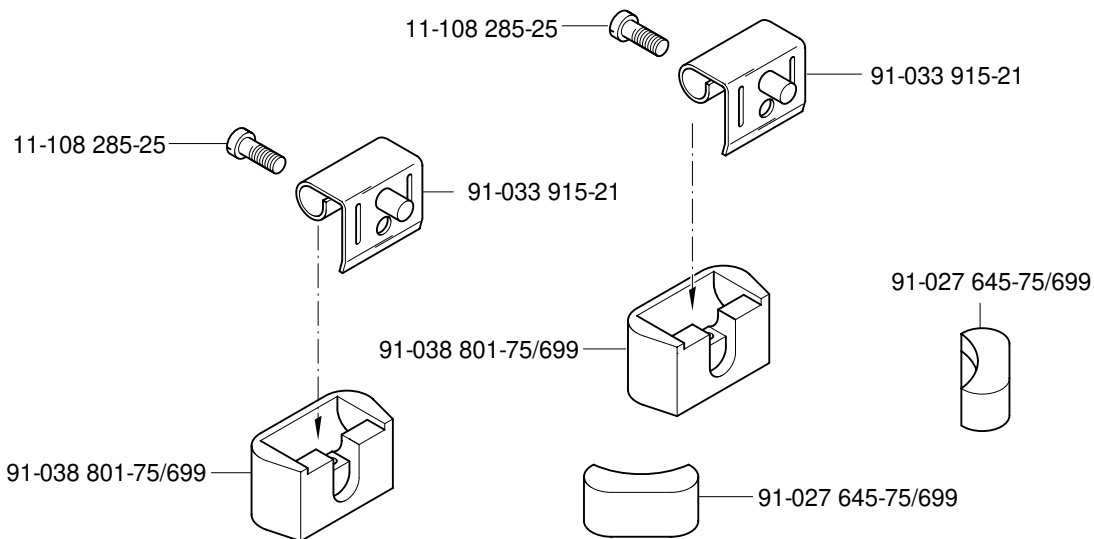

Keilriemen	PFAFF 1051
V-belt	PFAFF 1053
Courroie trapézoïdale	PFAFF 1181
Correa trapezoidal	PFAFF 1183

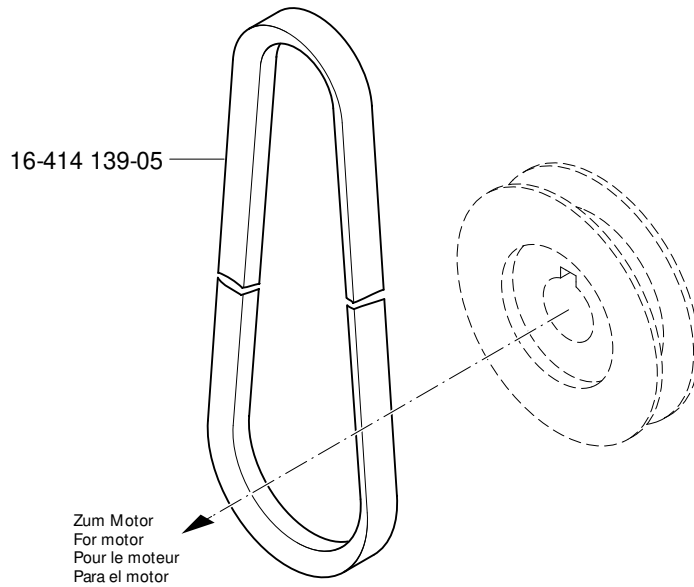

Knieüferteile	PFAFF 1051
Knee lifter parts	PFAFF 1053
Pièces du releveur de genouillère	PFAFF 1181
Piezas del alzaprensateles por rodillera	PFAFF 1183

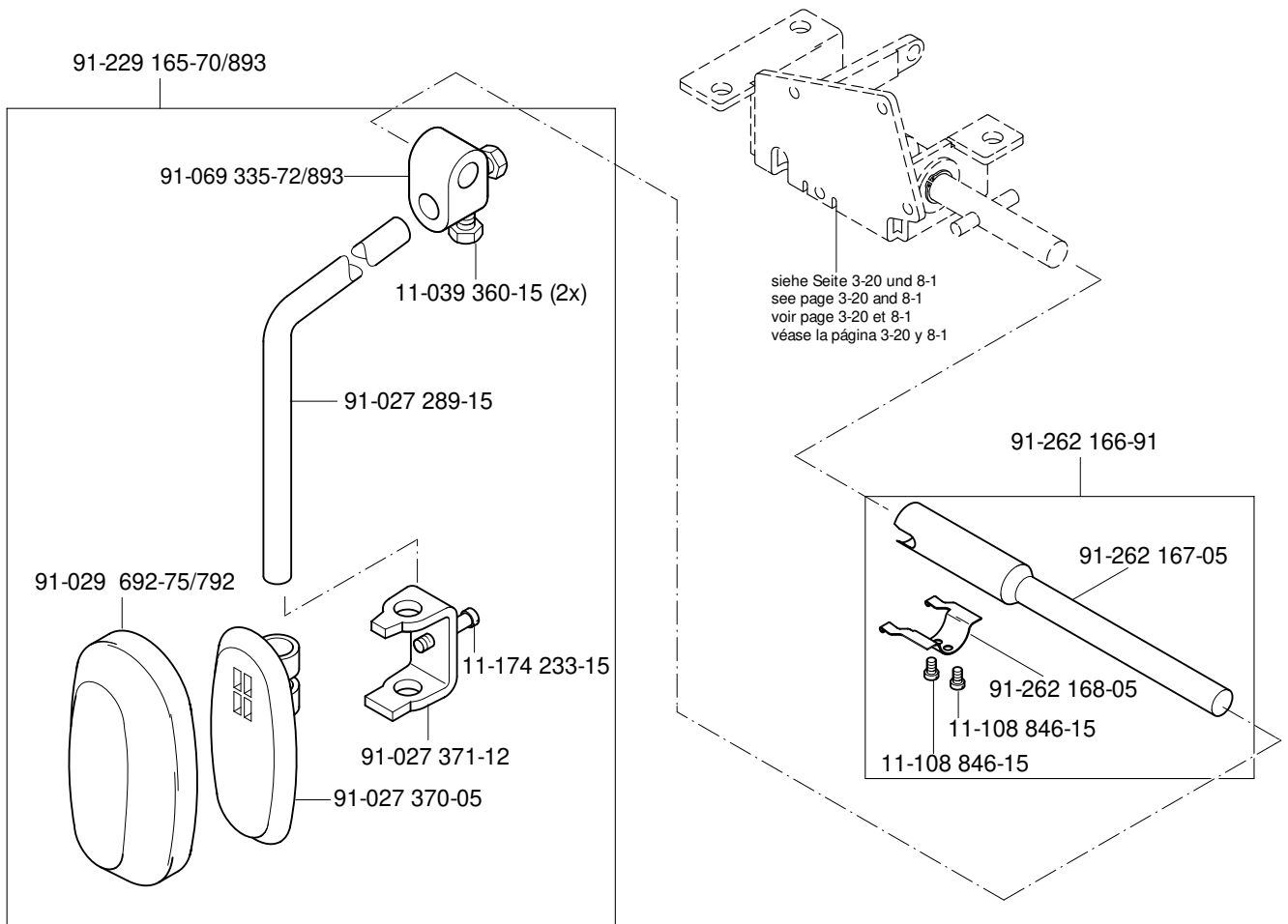

Öl Oil Huile Aceite	Mittelpunkts-Viskosität bei: Mean viscosity at: Viscosité moyenne à: Viscosidad media a:		Dichte bei: Density of: Densité à: Densidad a:		Bestellnummer für Behälter mit: Part number for can with: Numéro de commande pour récipients avec: Número de pedido para recipientes con:		
	°C	mm ² /s	°C	g/cm ³ (g/ml)	1 Liter 1 Litre 1 Litro	5 Liter 5 Litre 5 Litros	10 Liter 10 Litre 10 Litros
28-011 20 1-05	40	10,0	15	0,847	91-027 975-91	91-027 976-91	91-027 977-91

Fett Grease Graisse Grasa	Penetration Penetration Pénétration Penetración	Tropfpunkt Drip-point Point de suintement Punto de goteo	Bestellnummer für Behälter mit: Part number for can with: Numéro de commande pour récipients avec: Número de pedido para recipientes con:				
			mm/10	°C	0,25 kg	0,5 kg	1 kg
28-011 202-05							28-011 202-05
28-011 202-69							28-011 202-69

Reinigungsmittel Cleansing agent Agents de nettoyage Limpiadores	Bestellnummer für Behälter mit: Part number for can with: Numéro de commande pour récipients avec: Número de pedido para recipientes con:		
	240 ml		
Isopropyl-Alkohol	95-665 735-91		

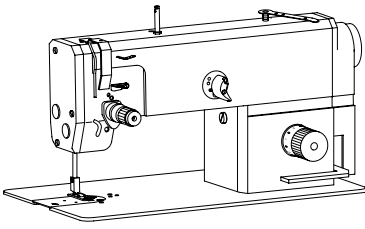

Anbausatz für externen Motor
 Mounting kit for external motor
 Jeu de pièces pour moteur externe
 Juego de piezas acoplables para motor externo

PFAFF 1051
 PFAFF 1053
 PFAFF 1181
 PFAFF 1183

16.01

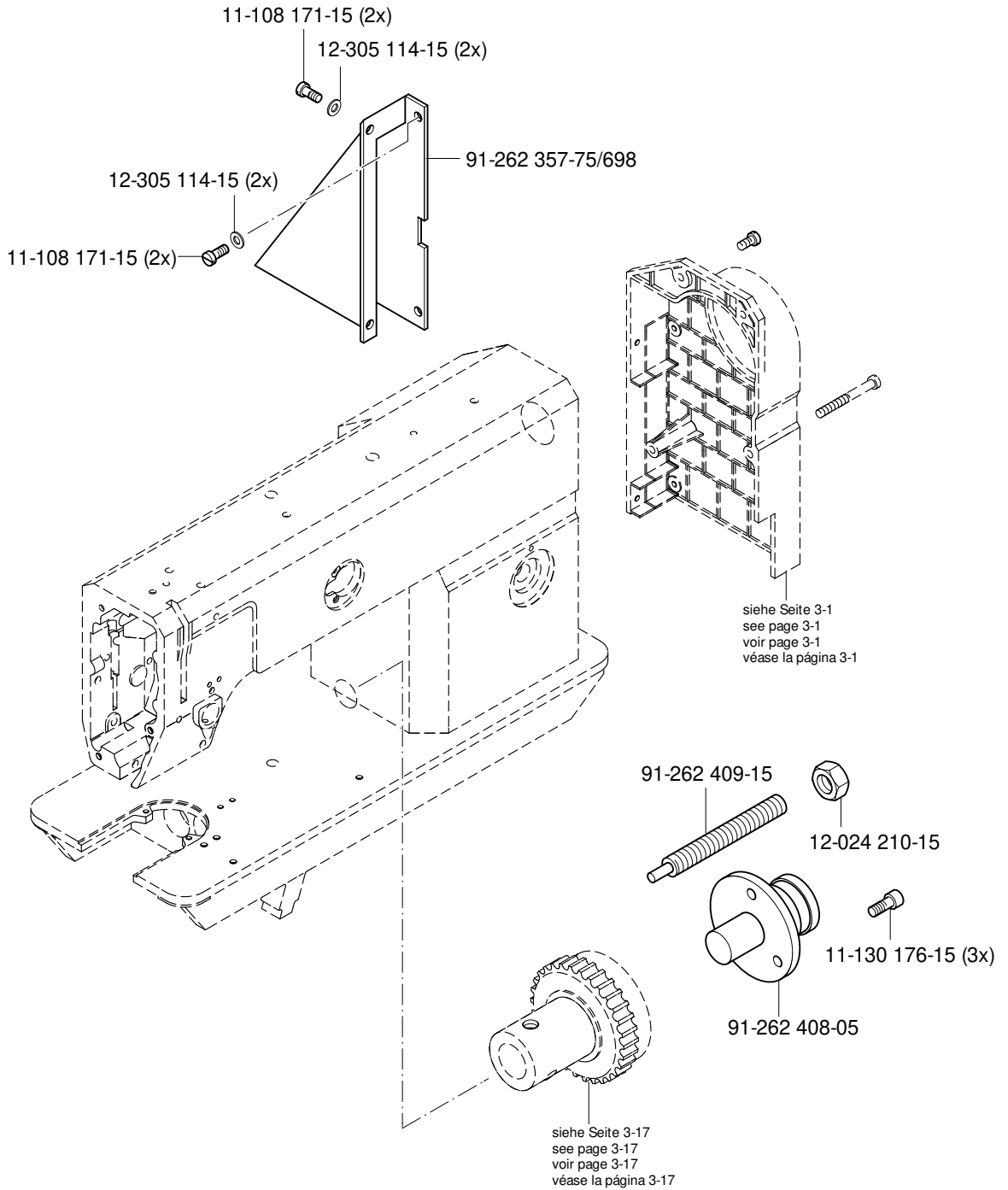

No.	Seite Page Pages Página	No.	Seite Page Pages Página	No.	Seite Page Pages Página	No.	Seite Page Pages Página
11-039 360-15	13 - 1	11-130 284-15	3 - 14	11-330 223-15	9 - 3	12-305 114-15	3 - 5, 9 - 3, 16 - 1
11-039 378-15	7 - 1	11-130 287-15	3 - 1, 3 - 8, 3 - 9, 3 - 18, 3 - 20, 8 - 1	11-330 232-15	3 - 20, 8 - 1	12-305 144-15	6 - 1
11-108 084-15	5 - 2, 5 - 3	11-130 293-15	8 - 1	11-330 277-15	3 - 6, 3 - 8, 3 - 10, 3 - 11, 3 - 12, 3 - 16, 3 - 18, 4 - 1, 5 - 2, 5 - 3, 5 - 4, 7 - 1	12-305 144-25	3 - 1, 9 - 2
11-108 087-15	5 - 2, 5 - 3	11-130 365-15	9 - 3	11-330 280-15	3 - 6	12-305 264-15	3 - 20, 8 - 1
11-108 096-15	4 - 3	11-132 172-15	3 - 2	11-330 952-15	3 - 2, 3 - 8, 3 - 12, 3 - 13, 3 - 14, 3 - 15, 3 - 16, 3 - 17, 3 - 20, 4 - 2, 5 - 2, 5 - 3, 8 - 1	12-305 904-05	5 - 4
11-108 102-15	9 - 3	11-132 223-15	3 - 2	11-330 955-15	3 - 4	12-335 151-15	5 - 5
11-108 135-15	4 - 2	11-170 281-15	3 - 7	11-330 958-15	4 - 1	12-335 171-15	3 - 9
11-108 171-15	16 - 1	11-173 168-25	3 - 2	11-330 962-15	3 - 14	12-341 090-25	3 - 12
11-108 174-15	9 - 1, 9 - 4	11-173 171-25	3 - 1	11-330 964-15	3 - 6, 3 - 17	12-349 901-05	3 - 16, 5 - 3
11-108 174-25	3 - 2	11-173 174-25	4 - 1	11-330 968-15	3 - 17	12-360 023-05	6 - 1
11-108 177-15	3 - 19, 6 - 1	11-174 176-15	4 - 2, 4 - 3	11-335 085-15	5 - 2, 5 - 3	12-360 023-05	6 - 1
11-108 180-15	6 - 1	11-174 233-15	13 - 1	11-335 223-15	9 - 3	12-360 054-05	3 - 9
11-108 222-15	3 - 15, 3 - 16, 5 - 2, 5 - 3, 5 - 5	11-178 172-15	4 - 3	11-335 280-15	3 - 6, 3 - 9, 3 - 11, 3 - 17	12-360 063-05	3 - 10, 3 - 12
11-108 222-25	3 - 1	11-178 223-25	3 - 10	11-341 166-15	3 - 17	12-360 064-05	3 - 3
11-108 225-15	3 - 17	11-180 283-25	3 - 1, 4 - 2	11-341 277-15	3 - 2, 3 - 4, 3 - 5	12-360 083-05	3 - 11
11-108 285-15	6 - 1	11-210 081-15	6 - 1	11-341 901-15	3 - 4	12-360 143-05	3 - 8
11-108 285-25	11 - 1	11-210 168-15	5 - 5	11-341 902-15	3 - 17	12-499 150-45	9 - 4
11-108 846-15	13 - 1	11-210 168-25	3 - 13	11-462 154-55	9 - 3	12-499 170-45	6 - 1
11-130 086-15	5 - 1	11-210 178-15	6 - 1	11-462 403-55	9 - 4, 9 - 5	12-510 140-45	3 - 1
11-130 101-15	6 - 1	11-210 265-15	3 - 6	12-005 154-15	5 - 1, 6 - 1	12-510 141-45	3 - 1
11-130 113-15	5 - 4	11-225 223-15	3 - 3	12-005 175-05	3 - 9	12-518 150-45	5 - 4
11-130 167-15	6 - 1	11-225 232-15	3 - 2, 5 - 1	12-005 195-15	4 - 2, 6 - 1	12-610 190-45	3 - 7, 3 - 8, 3 - 14, 3 - 17, 3 - 18, 5 - 4
11-130 170-25	9 - 2	11-250 084-25	3 - 13	12-005 215-15	7 - 1, 8 - 1	12-610 200-45	3 - 9, 4 - 3
11-130 173-15	3 - 1, 4 - 2, 4 - 3, 9 - 3	11-317 950-15	3 - 14, 6 - 1	12-024 151-15	5 - 5	12-610 210-45	3 - 3
11-130 176-15	3 - 5, 3 - 14, 4 - 2, 8 - 1, 16 - 1	11-317 971-15	3 - 4	12-024 171-15	3 - 20, 8 - 1	12-610 230-45	3 - 15, 3 - 16, 3 - 20, 5 - 2, 5 - 3, 8 - 1
11-130 185-15	3 - 1	11-320 171-15	3 - 10	12-024 191-15	4 - 2, 5 - 4	12-610 250-45	3 - 17
11-130 224-15	3 - 8, 3 - 9, 3 - 12, 3 - 17, 3 - 20, 4 - 2, 5 - 1, 8 - 1	11-330 085-15	3 - 3	12-024 191-25	3 - 13	12-610 280-45	3 - 18
11-130 224-25	3 - 1	11-330 166-15	3 - 8	12-024 210-15	16 - 1	12-618 170-45	3 - 1
11-130 227-15	4 - 3	11-330 175-15	3 - 13, 5 - 1	12-024 210-45	4 - 2, 5 - 4	12-618 210-45	3 - 11, 8 - 1
11-130 233-15	4 - 2, 6 - 1	11-330 205-15	9 - 4	12-624 200-45	5 - 1	12-624 200-45	5 - 1
11-130 257-25	3 - 1	11-330 217-15	3 - 15, 4 - 3	12-624 210-45	3 - 2	12-624 210-45	3 - 2
		11-330 220-15	3 - 2, 3 - 3, 3 - 4, 3 - 5, 4 - 2	12-624 280-45	3 - 8	12-624 280-45	3 - 8
				12-624 310-45	3 - 18	12-624 310-45	3 - 18

No.	Seite Page Pages Página	No.	Seite Page Pages Página	No.	Seite Page Pages Página	No.	Seite Page Pages Página
12-640 090-55	4 - 2	28-011 202-47	15 - 1	91-056 193-25	3 - 13, 5 - 1	91-069 632-05	4 - 2
12-640 130-55	3 - 2, 3 - 13	61-111 639-70	11 - 1	91-056 197-91	5 - 1	91-069 709-12	3 - 4
12-640 150-55	3 - 7, 3 - 10, 6 - 1	61-111 639-71	11 - 1	91-056 198-21	5 - 1	91-069 789-15	4 - 3
12-640 170-55	3 - 10, 4 - 2	71-110 003-35	6 - 1	91-056 578-91	3 - 13	91-088 881-11	6 - 1
12-640 200-55	3 - 12, 4 - 2	71-120 006-32	9 - 3	91-056 760-05	5 - 1	91-088 883-11	6 - 1
12-660 390-45	3 - 15, 3 - 16, 5 - 2, 5 - 3	71-130 006-39	9 - 2	91-069 056-05	3 - 4, 3 - 5	91-100 076-15	3 - 14
12-710 901-22	3 - 10	71-170 002-14	7 - 1	91-069 075-11	3 - 2	91-100 117-15	3 - 2
12-710 904-12	3 - 20, 8 - 1	71-170 002-15	5 - 5	91-069 079-72/895	3 - 2	91-100 270-25	3 - 12
13-030 341-05	3 - 1	71-170 002-16	6 - 1	91-069 105-25	3 - 2	91-100 281-25	3 - 13
13-033 190-05	5 - 2, 5 - 3	71-170 002-20	5 - 1	91-069 322-01	3 - 2	91-100 296-25	3 - 14
13-033 208-05	3 - 12	71-170 002-21	8 - 1	91-069 335-72/893	13 - 1	91-100 331-15	3 - 7
13-033 346-05	11 - 1	71-370 001-35	9 - 1	91-069 371-92	4 - 3	91-100 400-15	3 - 6
13-052 085-55	3 - 6, 3 - 8	71-523 555-61	9 - 3	91-069 434-91	3 - 2	91-105 482-05	3 - 12
13-063 193-05	3 - 15, 3 - 16, 5 - 2, 5 - 3	71-590 007-21	9 - 4	91-069 483-04	4 - 2	91-106 033-15	4 - 3
13-064 247-05	3 - 2	71-590 007-26	9 - 2	91-069 484-04	4 - 2	91-107 265-05	4 - 3
13-068 391-05	3 - 11	71-590 007-53	9 - 5	91-069 486-05	4 - 3	91-118 099-91	3 - 13
13-250 088-25	3 - 4	91-000 621-15	3 - 14	91-069 489-12	4 - 3	91-118 570-92	3 - 6
13-250 097-25	3 - 5	91-001 824-05	4 - 2	91-069 490-11	4 - 2	91-118 681-05	3 - 13
14-016 080-01	3 - 15, 3 - 16, 5 - 2, 5 - 3	91-004 181-05	3 - 14	91-069 493-11	4 - 2	91-118 683-05	3 - 13
14-016 101-91	3 - 17	91-009 035-25	3 - 13	91-069 496-05	4 - 2	91-118 685-05	3 - 13
14-016 151-91	3 - 6	91-021 124-15	6 - 1	91-069 498-11	4 - 3	91-118 711-05	3 - 14, 4 - 2
14-016 171-91	3 - 17	91-027 289-15	13 - 1	91-069 501-15	4 - 3	91-118 940-05	3 - 13
14-018 624-91	3 - 6	91-027 370-05	13 - 1	91-069 554-12	3 - 14	91-130 865-15	6 - 1
14-026 902-01	3 - 6	91-027 371-12	13 - 1	91-069 562-05	3 - 2	91-161 334-25	3 - 2
14-602 901-01	3 - 13	91-027 645-75/699	11 - 1	91-069 568-05	3 - 2	91-162 578-71/698	3 - 1
15-120 013-05	5 - 5	91-027 975-91	15 - 1	91-069 577-91	4 - 2	91-162 582-75/895	3 - 1
16-414 139-05	13 - 1	91-027 976-91	15 - 1	91-069 579-05	3 - 2	91-162 583-75/699	3 - 1
25-161 801-49	3 - 4, 3 - 5, 3 - 16, 5 - 3	91-027 977-91	15 - 1	91-069 585-25	3 - 13	91-162 596-25	3 - 2
25-161 801-52	3 - 4, 3 - 5, 3 - 16, 5 - 3	91-028 036-25	5 - 5	91-069 598-11	4 - 2	91-162 597-05	3 - 15, 3 - 16, 5 - 2, 5 - 3
25-308 820-60	3 - 11	91-029 692-75/792	13 - 1	91-069 599-15	4 - 2	91-162 690-92	3 - 2
26-536 301-09	3 - 4, 3 - 5, 3 - 16, 5 - 3	91-033 915-21	11 - 1	91-069 600-15	4 - 2	91-162 694-05	3 - 2
28-011 201-05	15 - 1	91-038 801-75/699	11 - 1	91-069 601-15	4 - 2	91-162 920-92	3 - 15, 3 - 16, 5 - 2, 5 - 3
28-011 202-05	15 - 1	91-056 192-25	3 - 13, 5 - 1	91-069 630-91	4 - 2	91-162 921-92	3 - 17

No.	Seite Page Pages Página	No.	Seite Page Pages Página	No.	Seite Page Pages Página	No.	Seite Page Pages Página
91-162 984-05	3 - 2	91-175 729-15	6 - 1	91-262 149-05	5 - 4	91-262 222-05	3 - 10
91-165 685-05	5 - 2, 5 - 3	91-175 732-15	6 - 1	91-262 150-91	3 - 17	91-262 225-91	5 - 2, 5 - 3
91-166 452-21	3 - 13	91-175 806-91	6 - 1	91-262 153-92	3 - 17	91-262 226-91	3 - 15, 3 - 16, 5 - 2, 5 - 3
91-167 590-15	3 - 1	91-229 068-75/895	10 - 1	91-262 156-91	3 - 18	91-262 228-01	3 - 19
91-168 347-05	3 - 18	91-229 069-75/895	10 - 1	91-262 161-72/698	3 - 6	91-262 231-72/893	3 - 11
91-168 480-15	3 - 6	91-229 070-70/895	10 - 1	91-262 162-75/698	3 - 1	91-262 232-11	3 - 11
91-169 457-12	3 - 4	91-229 071-71/895	10 - 1	91-262 164-12	3 - 20, 8 - 1	91-262 235-15	5 - 2, 5 - 3
91-169 474-05	4 - 3	91-229 072-45	10 - 1	91-262 166-91	13 - 1	91-262 236-91	3 - 16
91-169 475-15	4 - 2	91-229 073-71/895	10 - 1	91-262 167-05	13 - 1	91-262 237-91	3 - 16
91-169 556-05	3 - 7, 3 - 8, 3 - 14, 3 - 17, 5 - 4	91-229 074-05	10 - 1	91-262 168-05	13 - 1	91-262 244-92	3 - 18
91-171 042-05	3 - 13	91-229 075-45	10 - 1	91-262 174-11	3 - 7	91-262 245-04	3 - 18
91-171 049-05	3 - 13	91-229 076-75/698	10 - 1	91-262 179-05	3 - 7	91-262 250-91	3 - 16
91-171 050-05	3 - 2	91-229 077-72/895	10 - 1	91-262 181-05	3 - 7	91-262 273-05	8 - 1
91-171 068-05	3 - 2	91-229 078-25	10 - 1	91-262 183-75/895	3 - 1	91-262 274-05	3 - 11
91-171 158-92	3 - 17	91-229 079-25	10 - 1	91-262 184-05	5 - 2, 5 - 3	91-262 277-05	3 - 14
91-171 409-12	3 - 18	91-229 080-25	10 - 1	91-262 185-05	5 - 2, 5 - 3	91-262 278-11	3 - 10
91-171 441-01	3 - 8	91-229 081-25	10 - 1	91-262 187-15	3 - 15, 3 - 16, 5 - 2, 5 - 3	91-262 300-91	3 - 14
91-171 785-05	5 - 3	91-229 082-25	10 - 1	91-262 188-15	5 - 2, 5 - 3	91-262 301-12	3 - 14
91-171 811-15	3 - 7	91-229 123-25	10 - 1	91-262 189-91	5 - 2, 5 - 3	91-262 304-45	3 - 3
91-171 853-15	5 - 2, 5 - 3	91-229 124-25	10 - 1	91-262 195-92	3 - 6	91-262 320-91	3 - 5
91-172 676-05	3 - 18	91-229 125-25	10 - 1	91-262 196-05	3 - 6	91-262 326-15	3 - 1
91-173 967-15	6 - 1	91-229 126-25	10 - 1	91-262 197-05	3 - 12	91-262 329-75/895	3 - 1
91-173 968-15	6 - 1	91-229 127-25	10 - 1	91-262 200-91	3 - 12	91-262 331-91	3 - 15, 3 - 16
91-174 016-05	3 - 5	91-229 128-25	10 - 1	91-262 201-05	3 - 12	91-262 336-91	3 - 4
91-174 223-05	6 - 1	91-229 129-25	10 - 1	91-262 202-15	3 - 12	91-262 344-91	3 - 8
91-174 783-05	3 - 13	91-229 165-70/893	13 - 1	91-262 203-05	3 - 12	91-262 345-12	3 - 8
91-174 851-05	5 - 1	91-262 061-05	3 - 17	91-262 208-05	5 - 2, 5 - 3	91-262 346-12	3 - 8
91-174 879-05	3 - 13	91-262 062-92	3 - 17	91-262 209-91	5 - 3	91-262 347-05	3 - 8
91-175 203-05	3 - 18	91-262 069-15	5 - 4	91-262 210-92	3 - 10	91-262 348-91	3 - 9
91-175 265-12	6 - 1	91-262 136-15	5 - 4	91-262 214-05	3 - 15, 3 - 16, 5 - 2, 5 - 3	91-262 354-05	3 - 3
91-175 354-15	6 - 1	91-262 138-15	5 - 4	91-262 215-91	5 - 3	91-262 355-12	3 - 12
91-175 557-11	5 - 1	91-262 143-05	5 - 5	91-262 218-05	3 - 10	91-262 357-75/698	16 - 1
		91-262 146-91	5 - 4	91-262 219-91	3 - 10	91-262 360-05	3 - 15, 3 - 16, 5 - 2, 5 - 3

No.	Seite Page Pages Página	No.	Seite Page Pages Página	No.	Seite Page Pages Página	No.	Seite Page Pages Página
91-262 372-92	8 - 1	91-262 565-92	4 - 1	91-262 820-91	3 - 3	91-265 198-15	3 - 7
91-262 376-91	3 - 16	91-262 566-92	3 - 17	91-262 821-91	3 - 3	91-266 397-01	3 - 13
91-262 377-91	3 - 15, 3 - 16	91-262 567-05	9 - 3	91-262 824-96	3 - 14	91-268 076-15	3 - 16, 5 - 3
91-262 385-75/893	9 - 4	91-262 569-91	5 - 1	91-262 825-91	3 - 14	91-290 733-91	3 - 1
91-262 408-05	16 - 1	91-262 572-15	3 - 1	91-262 830-11	3 - 7	91-700 785-15	3 - 18
91-262 409-15	16 - 1	91-262 573-05	3 - 20, 8 - 1	91-262 834-15	9 - 3	91-701 179-15	3 - 14
91-262 410-92	3 - 12	91-262 576-05	9 - 3	91-262 835-91	9 - 3	91-701 346-15	4 - 3
91-262 415-91	5 - 2	91-262 577-75/698	3 - 12	91-262 836-01	3 - 4	91-701 391-15	4 - 3
91-262 416-91	5 - 2	91-262 578-71/698	3 - 12	91-262 837-91	3 - 4	95-600 649-05	6 - 1
91-262 417-91	3 - 15	91-262 579-15	8 - 1	91-262 838-91	3 - 8	95-665 735-91	15 - 1
91-262 418-91	3 - 15	91-262 671-91	5 - 4	91-262 839-91	3 - 8	95-669 358-05	3 - 16, 5 - 3
91-262 421-91	3 - 5	91-262 677-12	3 - 20, 8 - 1	91-262 840-91	3 - 17	95-784 314-91	9 - 1
91-262 422-05	3 - 4, 3 - 5	91-262 678-91	5 - 1	91-262 841-91	3 - 17	96-108 031-38	9 - 2
91-262 437-05	3 - 15, 3 - 16	91-262 679-91	8 - 1	91-262 853-91	3 - 7	99-069 722-01	3 - 4
91-262 438-01	3 - 15	91-262 680-91	3 - 20	91-262 854-91	3 - 4	99-133 220-01	3 - 4
91-262 440-71/895	6 - 1	91-262 686-91	3 - 14	91-262 903-15	9 - 3	99-137 151-45	3 - 13
91-262 441-75/895	6 - 1	91-262 687-25	3 - 14	91-262 884-91	3 - 14	99-137 186-05	3 - 15, 3 - 16
91-262 442-75/895	6 - 1	91-262 688-91	3 - 6	91-262 885-25	3 - 14	99-137 187-15	3 - 15, 3 - 16
91-262 446-15	7 - 1	91-262 689-91	3 - 6	91-264 132-75/895	4 - 1	99-137 188-15	3 - 15, 3 - 16
91-262 447-05	7 - 1	91-262 690-01	3 - 6	91-264 133-75/895	4 - 2	99-137 189-05	3 - 15, 3 - 16
91-262 457-12	3 - 2	91-262 691-91	3 - 3	91-264 134-91	4 - 3	99-137 190-05	3 - 15, 3 - 16
91-262 460-15	6 - 1	91-262 692-05	3 - 3	91-264 136-05	4 - 2	99-137 191-05	3 - 15, 3 - 16
91-262 461-15	6 - 1	91-262 751-91	3 - 3	91-264 139-72/895	4 - 3	99-137 192-05	3 - 15, 3 - 16
91-262 465-15	3 - 20, 8 - 1	91-262 760-91	3 - 10	91-264 140-15	4 - 2	99-137 193-05	3 - 15, 3 - 16
91-262 513-05	6 - 1	91-262 761-71/895	3 - 1	91-264 141-91	4 - 1	99-137 194-05	3 - 15, 3 - 16
91-262 514-05	5 - 2	91-262 786-91	3 - 3	91-264 144-75/895	4 - 2	99-137 196-05	9 - 4
91-262 525-75/895	9 - 2	91-262 787-91	3 - 3	91-264 145-05	4 - 2	99-137 226-91	9 - 4
91-262 536-15	3 - 1	91-262 788-91	3 - 3	91-264 146-05	4 - 2	99-137 247-45	3 - 1
91-262 544-91	3 - 6	91-262 804-91	3 - 14	91-264 147-71/895	4 - 3	S-414 988-380-435	3 - 2
91-262 551-91	3 - 4	91-262 805-25	3 - 14	91-264 149-01	4 - 2		
91-262 552-12	3 - 12	91-262 806-05	3 - 14	91-264 150-01	4 - 2		
91-262 554-92	3 - 8	91-262 813-91	3 - 10	91-265 065-05	5 - 3		
91-262 559-15	5 - 1	91-262 815-11	3 - 1	91-265 189-05	3 - 14		

PFAFF

1051

1053

Unterklassen-Ausstattung

Subclass parts

Composition des sous-classes

Composición de las subclases

1181

1183

18.01

Nähwerkzeuge
Gauge parts
Organes de couture PFAFF 1051
Organos de costura PFAFF 1181

-8/11 B♦

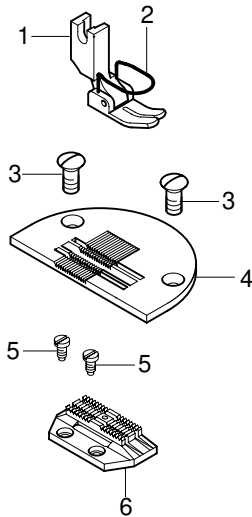

Pos.-Nr. Item No. N° pos. N° de pos.	Teile-Nr. Part No. N° de pieces N° de pieza
1 - 6	91-202 308-91
1 - 2	91-154 748-21
2	91-154 744-05
3	91-100 296-25
4	91-150 671-25
5	91-701 179-15
6	91-059 816-05

1181-731/01-8/11 A♦

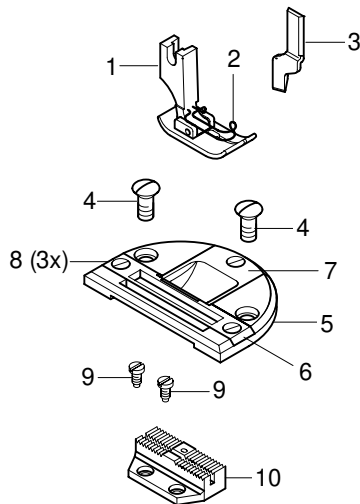

Pos.-Nr. Item No. N° pos. N° de pos.	Schneabstand in mm Trimming margin in mm Distance de coupe en mm Marge de corte en mm	Teile-Nr. Part No. N° de pieces N° de pieza
1 - 10	5,0	91-202 363-93/002
1 - 2	5,0	91-054 426-03/019
2		91-057 104-05
3	5,0	91-069 595-04/002
4		91-100 296-25
5 - 8	5,0	91-150 676-93/001
5		91-150 677-05
6	5,0	91-048 716-03/003
7	5,0	91-048 703-04/006
8		91-000 730-25
9		91-701 179-15
10	5,0	91-059 833-04/005

-731/01-8/11 B♦

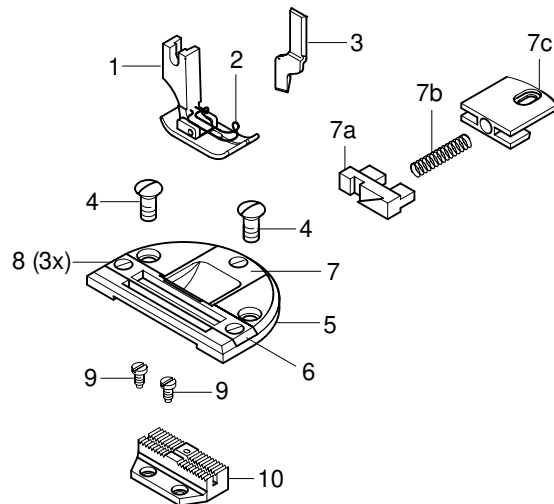

Pos.-Nr. Item No. N° pos. N° de pos.	Schneibstand in mm Trimming margin in mm Distance de coupe en mm Margeb de corte en mm	Teile-Nr. Part No. N° de piezas N° de piezas
1 - 10	3,5 4,0 4,5 5,0 6,0 7,0	91-202 378-93/001 91-202 363-93/003 91-202 363-93/004 91-202 363-93/001 91-202 363-93/005 91-202 363-93/006
1 - 2	3,5 4,0 4,5 5,0 6,0 7,0	91-054 426-03/016 91-054 426-03/017 91-054 426-03/018 91-054 426-03/019 91-054 426-03/020 91-054 426-03/021
2		91-057 104-05
3	3,5 4,0 - 7,0	91-169 395-04/002 91-069 595-04/002
4		91-100 296-25
5 - 8	3,5 4,0 4,5 5,0 6,0 7,0	91-150 717-93/001 91-150 676-93/002 91-150 676-93/003 91-150 676-93/001 91-150 676-93/004 91-150 676-93/005
5		91-150 677-05

Pos.-Nr. Item No. N° pos. N° de pos.	Schneibstand in mm Trimming margin in mm Distance de coupe en mm Margeb de corte en mm	Teile-Nr. Part No. N° de piezas N° de piezas
6	3,5 4,0 4,5 5,0 6,0 7,0	91-150 718-03/001 91-048 716-03/001 91-048 716-03/002 91-048 716-03/003 91-048 716-03/005 91-048 716-03/007
7	4,0 4,5 5,0 6,0 7,0	91-048 703-04/004 91-048 703-04/005 91-048 703-04/006 91-048 703-04/008 91-048 703-04/010
7a	3,5	91-058 178-05
7b	3,5	91-169 608-05
7c	3,5	91-150 720-05
8		91-000 730-25
9		91-701 179-15
10	3,5 4,0 4,5 5,0 6,0 7,0	91-046 467-04/006 91-059 833-04/002 91-059 833-04/004 91-059 833-04/006 91-059 833-04/008 91-059 833-04/010

18.01

Nähwerkzeuge
Gauge parts
Organes de couture PFAFF 1051
Organos de costura PFAFF 1181

-8/12 A♦

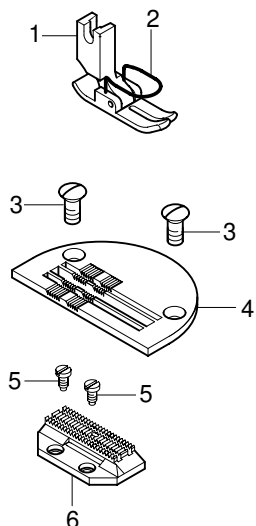

Pos.-Nr. Item No. N° pos. N° de pos.	Teile-Nr. Part No. N° de pieces N° de pieza
1 - 6	91-202 309-93/001
1 - 2	91-154 751-23/001
2	91-154 744-05
3	91-100 296-25
4	91-150 673-25
5	91-701 179-15
6	91-059 812-04/001

1181-8/13 CN♦

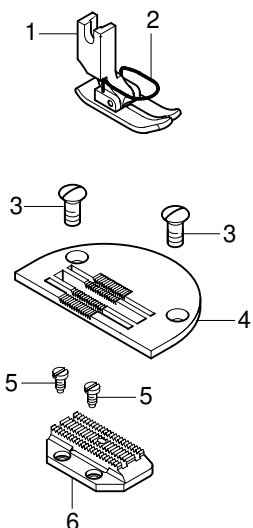

Pos.-Nr. Item No. N° pos. N° de pos.	Teile-Nr. Part No. N° de pieces N° de pieza
1 - 6	91-202 310-93/001
1 - 2	91-154 741-23/001
2	91-154 744-05
3	91-100 296-25
4	91-150 672-25
5	91-701 179-15
6	91-059 961-05

-8/31 A♦

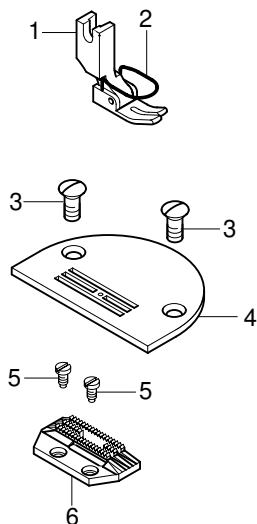

Pos.-Nr. Item No. N° pos. N° de pos.	Teil-Nr. Part No. N° de piezas N° de pieza
1 - 6	91-202 355-93/001
1 - 2	91-154 756-23/001
2	91-154 744-05
3	91-100 296-25
4	91-154 694-24/002
5	91-701 179-15
6	91-059 968-05

-8/31 B♦

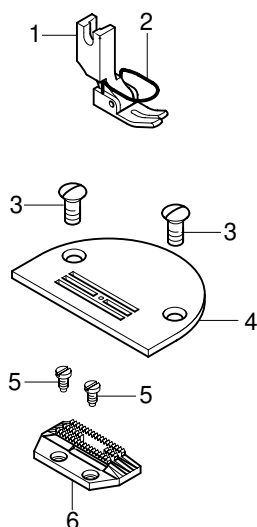

Pos.-Nr. Item No. N° pos. N° de pos.	Teil-Nr. Part No. N° de piezas N° de pieza
1 - 6	91-202 356-93/001
1 - 2	91-154 753-21
2	91-154 744-05
3	91-100 296-25
4	91-154 694-24/001
5	91-701 179-15
6	91-059 968-05

-8/33 CN♦

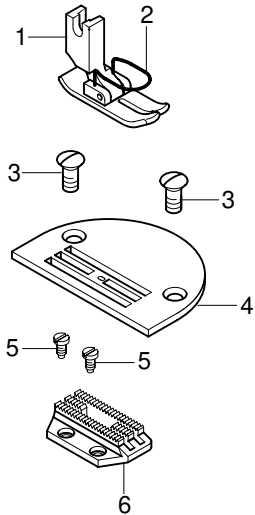

Pos.-Nr. Item No. N° pos. N° de pos.	Teile-Nr. Part No. N° de piezas N° de pieza
1 - 6	91-202 357-93/001
1 - 2	91-154 758-23/001
2	91-154 744-05
3	91-100 296-25
4	91-150 693-25
5	91-701 179-15
6	91-059 967-05

-8/44 A♦

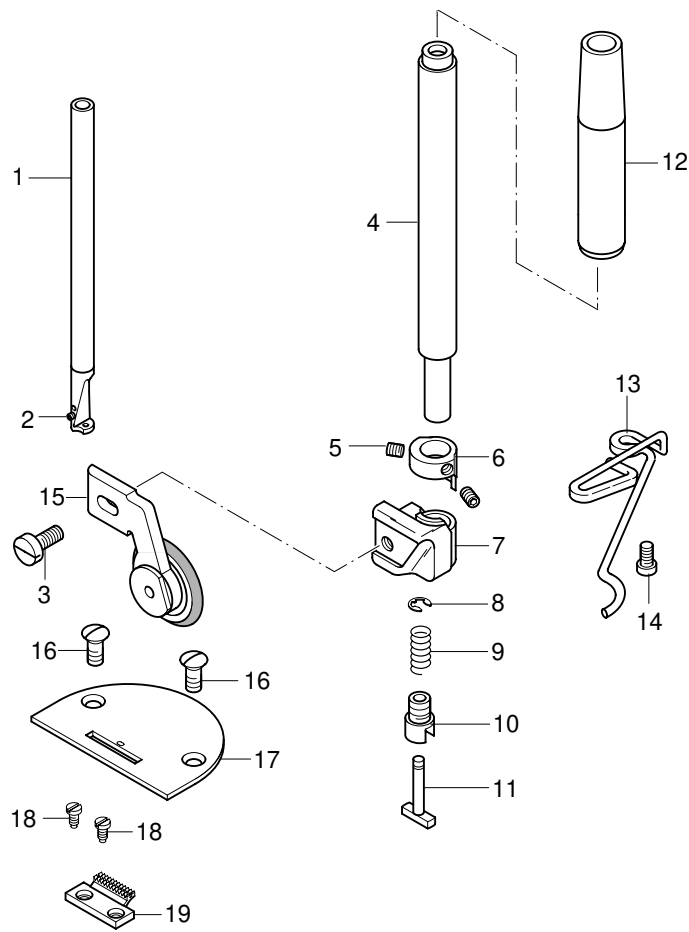

Pos.-Nr. Item No. N° pos. N° de pos.	Teile-Nr. Part No. N° de piezas N° de pieza	Pos.-Nr. Item No. N° pos. N° de pos.	Teile-Nr. Part No. N° de piezas N° de pieza
1 - 19	91-202 358-93/001	12	91-171 557-05
1 - 2	91-262 565-92	13	91-262 520-25
2	11-330 085-15	14	11-132 172-15
3	91-700 717-15	15	91-051 155-93/001
4	91-171 076-01	16	91-100 296-25
5	91-700 388-15	17	91-150 695-24/001
6	91-169 322-15	18	91-701 179-15
7	91-169 323-15	19	91-059 969-04/001
8	12-640 070-55		
9	91-025 376-05		
10	91-700 409-15		
11	91-025 374-05		

-8/44 B♦

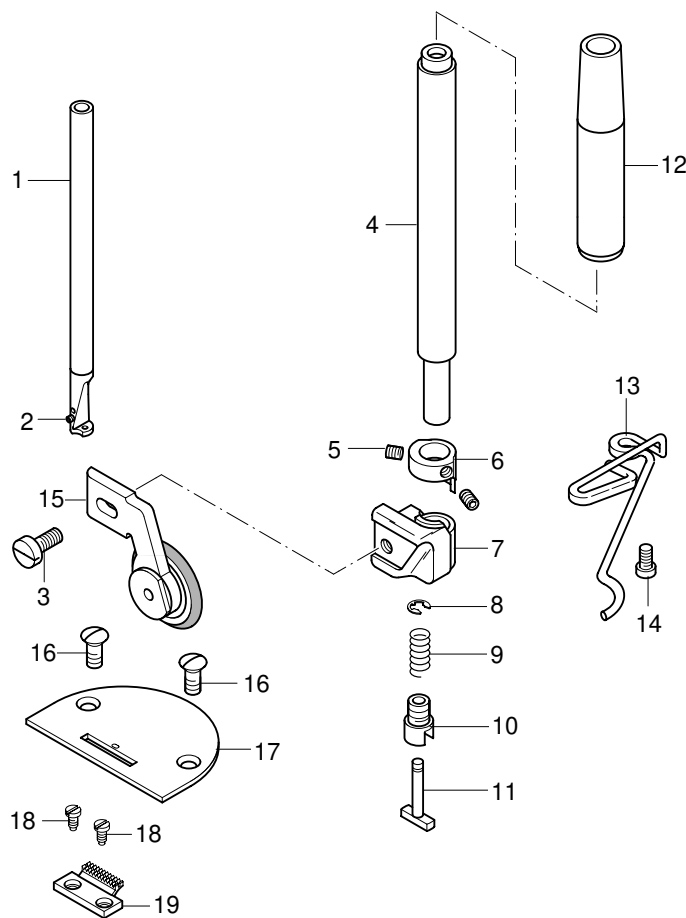

Pos.-Nr. Item No. N° pos. N° de pos.	Teil-Nr. Part No. N° de piezas N° de pieza
1 - 19	91-202 358-93/002
1 - 2	91-262 565-92
2	11-330 085-15
3	91-700 717-15
4	91-171 076-01
5	91-700 388-15
6	91-169 322-15
7	91-169 323-15
8	12-640 070-55
9	91-025 376-05
10	91-700 409-15
11	91-025 374-05

Pos.-Nr. Item No. N° pos. N° de pos.	Teil-Nr. Part No. N° de piezas N° de pieza
12	91-171 557-05
13	91-262 520-25
14	11-132 172-15
15	91-051 155-93/001
16	91-100 296-25
17	91-150 695-24/002
18	91-701 179-15
19	91-059 969-04/002

-8/44 CN♦

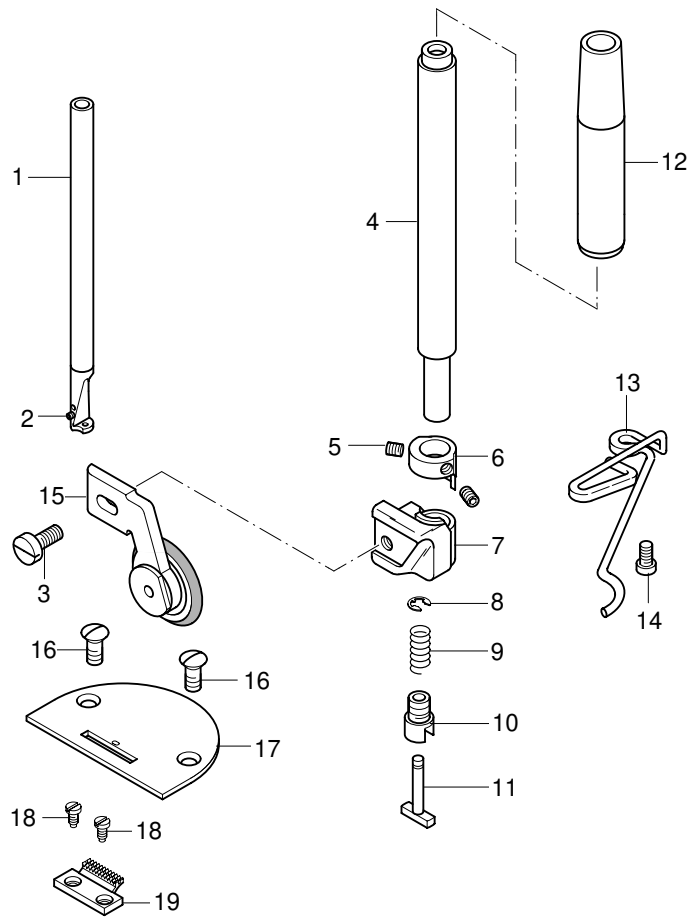

Pos.-Nr. Item No. N° pos. N° de pos.	Teile-Nr. Part No. N° de pieces N° de pieza
1 - 19	91-202 358-93/003
1 - 2	91-262 565-92
2	11-330 085-15
3	91-700 717-15
4	91-171 076-01
5	91-700 388-15
6	91-169 322-15
7	91-169 323-15
8	12-640 070-55
9	91-025 376-05
10	91-700 409-15
11	91-025 374-05

Pos.-Nr. Item No. N° pos. N° de pos.	Teile-Nr. Part No. N° de pieces N° de pieza
12	91-171 557-05
13	91-262 520-25
14	11-132 172-15
15	91-051 155-93/002
16	91-100 296-25
17	91-150 695-24/003
18	91-701 179-15
19	91-059 969-04/003