

Cloth Puller

先引きローラ

**V045 · V046**

# PARTS LIST

## HOW TO MAKE USE OF THIS PARTS LIST

1. As to "#01" and "#02" refer to the "Note" given at the bottom of the respective pages.
2. Codes on the "Qty" column
  - Each numeral indicates the number of parts required.
  - "0.1" and "2.5" indicate the length (in meters) of the respective parts.
3. Parentheses mean that the corresponding part is a subpart that constructs an assembly part.
4. Dotted lines on the Figures indicate assembly parts.

### パーツリストご利用に際して

1. リストページの#01、#02等の印は、ページ下の"注記"の説明をご参照下さい。
2. 数量欄の数字は、個数を表し、0.1、2.5等の数値は、長さ(単位メートル)を表します。
3. 数量欄の( )は、組部品を構成している子部品であることを意味します。
4. イラストページの-----枠は、組構成であることを意味します。



# CONTENTS

## 目 次

1. FRAME & COVER COMPONENTS .....	1
フレーム・カバー関係	
2. DRIVE COMPONENTS .....	2
駆動関係	
3. CLUTCH COMPONENTS .....	3
クラッチ関係	
4. ROLLER DRIVE COMPONENTS .....	5
ローラー駆動関係	
5. PRESSER COMPONENTS (V045 MODEL) .....	7
押さえ関係 (V045仕様)	
6. PRESSER COMPONENTS (V046 MODEL) .....	9
押さえ関係 (V046仕様)	
7. LOWER ROLLER COMPONENTS (V046 MODEL) .....	10
下ローラー関係 (V046仕様)	
8. EXCHANGING PARTS AT USING V045 UNIT (FOR MS-1190・1190M) .....	11
V045取付時の交換部品 (MS-1190・1190M用)	
9. EXCHANGING PARTS AT USING V045 UNIT (FOR MS-1261・1260・1261M) .....	12
V045取付時の交換部品 (MS-1261・1260・1261M用)	
10. TABLE OF V045 EXCHANGING GAUGE PARTS (FOR MS-1190・1190M) .....	13
V045交換ゲージ一覧表 (MS-1190・1190M用)	
11. TABLE OF V045 EXCHANGING GAUGE PARTS (FOR MS-1261・1260・1261M) .....	14
V045交換ゲージ一覧表 (MS-1261・1260・1261M用)	
NUMERICAL INDEX OF PARTS .....	15
索引	

# I. FRAME & COVER COMPONENTS

フレーム・カバー関係

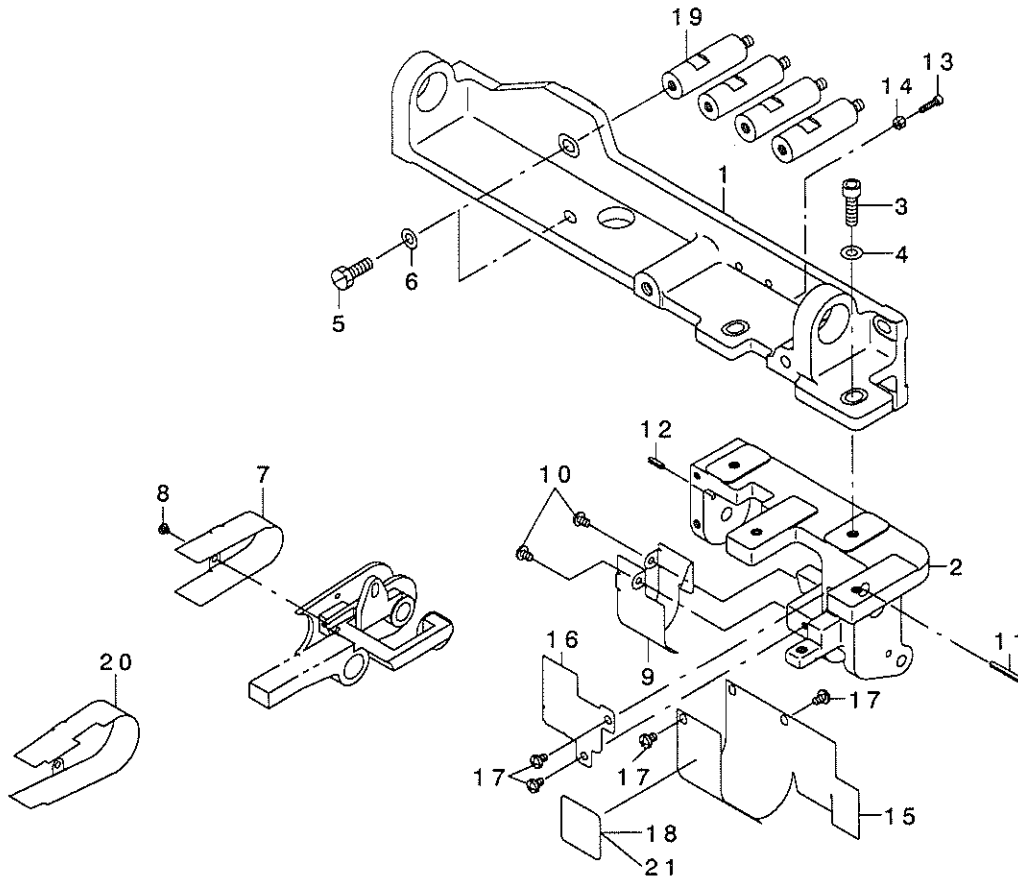

REF. NO	NOTE	PART NO.	DESCRIPTION	ヒンメイ	Qty
1		MAV-04501000	MAIN BASE	メインベース	1
2		MAV-04502000	CLUTCH BASE	クラッチベース	1
3		SM-6062002-TP	SCREW M6 L=20	ロツカクアナボルト M6 L=20	2
4		WP-0641600-SC	WASHEW 6.4X12.5X1.6	ヒラサガネ	2
5		SM-9061850-SC	SCREW M6 L=18	ロツカクボルト M6 L=18	4
6		WP-0641600-SC	WASHEW 6.4X12.5X1.6	ヒラサガネ	4
7	#01	MAV-04503000	ROLLER COVER	ローラーカバー	1
8		SM-5030355-SE	SCREW	ハイントネジ	2
9		MAV-04504000	INTERMEDIATE PULLEY COVER	チューカンアローカバー	1
10		SM-5040655-SN	SCREW	ハイントネジ	3
11		PS-0300242-K0	SPRING PIN 3.0X24	スプリングピン 3.0X24	1
12		PS-0300102-K0	SPRING PIN 3.0X10	スプリングピン 3.0X10	1
13		SM-6031202-TP	SCREW M3X0.5 L=12	ロツカクアナボルト	1
14		NM-6030003-SC	NUT M3	ロツカクナツト M3	1
15		MAV-04505000	CLUTCH COVER A	クラッチカバー (A)	1
16		MAV-04506000	CLUTCH COVER B	クラッチカバー B	1
17		SM-5040655-SN	SCREW	ハイントネジ	5
18	#01	MAV-04507000	MODEL PLATE	モデルプレート	1
19	#02	MAV-04611000	BASE FLOAT PIN	ベースフロートピン	4
20	#02	MAV-04603000	ROLLER COVER	ローラーカバー	1
21	#02	MAV-04607000	MODEL PLATE	モデルプレート	1

NOTE (注記)

#01...FOR V045

V045用

#02...FOR V046

V046用

## 2. DRIVE COMPONENTS

駆動関係

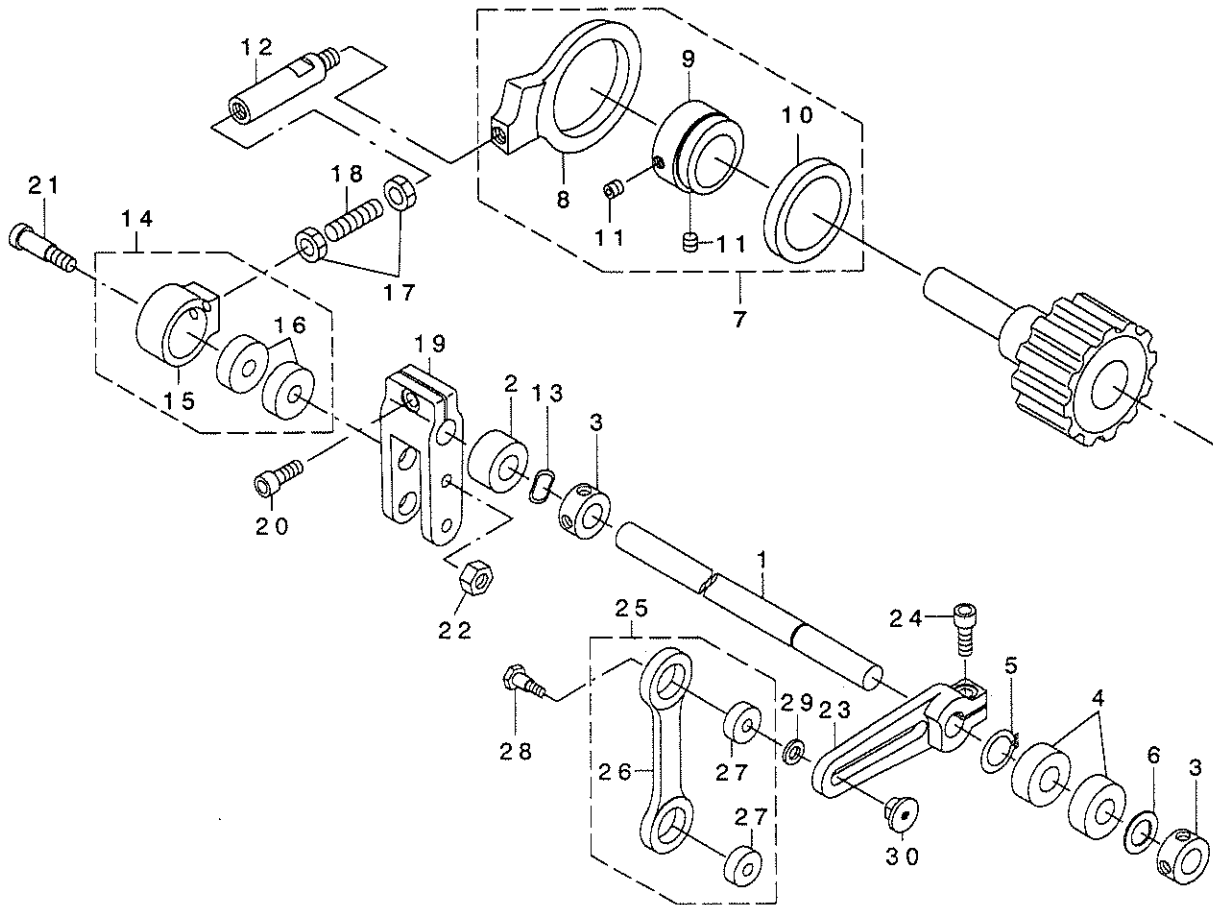

REF. NO	NOTE	PART NO.	DESCRIPTION	ト	ン	メ	イ	Qty
1		MAV-04515000	ROCKING SHAFT	ヨウト	ウツヤフト			1
2		SB-2120001-00	BEARING	コロカ	リジ	クウケ		1
3		CS-1201010-SH	THRUST COLLAR ASM. D=12 W=10	スラストウケ	D=12 W=10	クミ		2
4		SB-1120005-00	BEARING	コロカ	リジ	クウケ		2
5		RC-1200001-KP	C-SHAPED SNAP RING	Cカ	タトメ			1
6		WP-1221016-SP	WASHER	ヒラサ	カネ			1
7		MAV-045160B0	ROCKING CRANK	ヨウト	ウクラソク(クミ)B			1
8		MAV-04516000	ROCKING CRANK	ヨウト	ウクラソク			(1)
9		MAV-04517000	ECCENTRIC SHAFT	ヘンソクソク	ク			(1)
10		SB-1350003-00	BEARING	コロカ	リジ	クウケ		(1)
11		SM-8060602-TP	SCREW M6X6	トメネジ	M6 L=6			(2)
12	#01	MAV-04610000	CONNECTING ROD	ヨウト	ウセツソク	クロット		1
13		WZ-1200200-KP	WAVED WASHER	ナミカ	タサ	カネ		1
14		MAV-045180A0	ROCKING CRANK HOUSING ASM.	ヨウト	ウクラソクハウジング	ソク	クミ	1
15		MAV-04518000	ROCKING CRANK HOUSING	ヨウト	ウクラソクハウジング	ソク		(1)
16		SB-1080006-00	BEARING	コロカ	リジ	クウケ		(2)
17		NM-6080003-SC	NUT M8	ロツカクナツト	M8	3シユ		2
18		SM-8082502-TP	SCREW	トメネジ				1
19		MAV-04519000	ROCKING ROD	ヨウト	ウロツト			1
20		SM-6061602-TP	SCREW M6 L=16	ロツカクアナボ	ルト			1
21		SD-0801606-SH	STEP-SCREW	ダ	ンネジ			1
22		NM-6060003-SC	NUT M6	ロツカクナツト	M6			1
23		MAV-04520000	ADJUSTING ROD	アジ	ヤストロツト			1
24		SM-6061602-TP	SCREW M6 L=16	ロツカクアナボ	ルト			1
25		MAV-045210A0	JOINT ROD ASM.	ジ	ヨイントロツト	(クミ)		1
26		MAV-04521000	JOINT ROD	ジ	ヨイントロツト			(1)
27		SB-1060002-00	BEARING 6X17	ベ	アリソク	6X17		(2)
28		SD-0600756-TP	STEP-SCREW	ダ	ンネジ			1
29		WP-0641600-SC	WASHEW 6.4X12.5X1.6	ヒラサ	カネ			1
30		MAV-04522000	ADJUSTING PIN	アジ	ヤストピ	ン		1

NOTE (注記)

#01...FOR V046

V046用

### 3. CLUTCH COMPONENTS

クラッチ関係

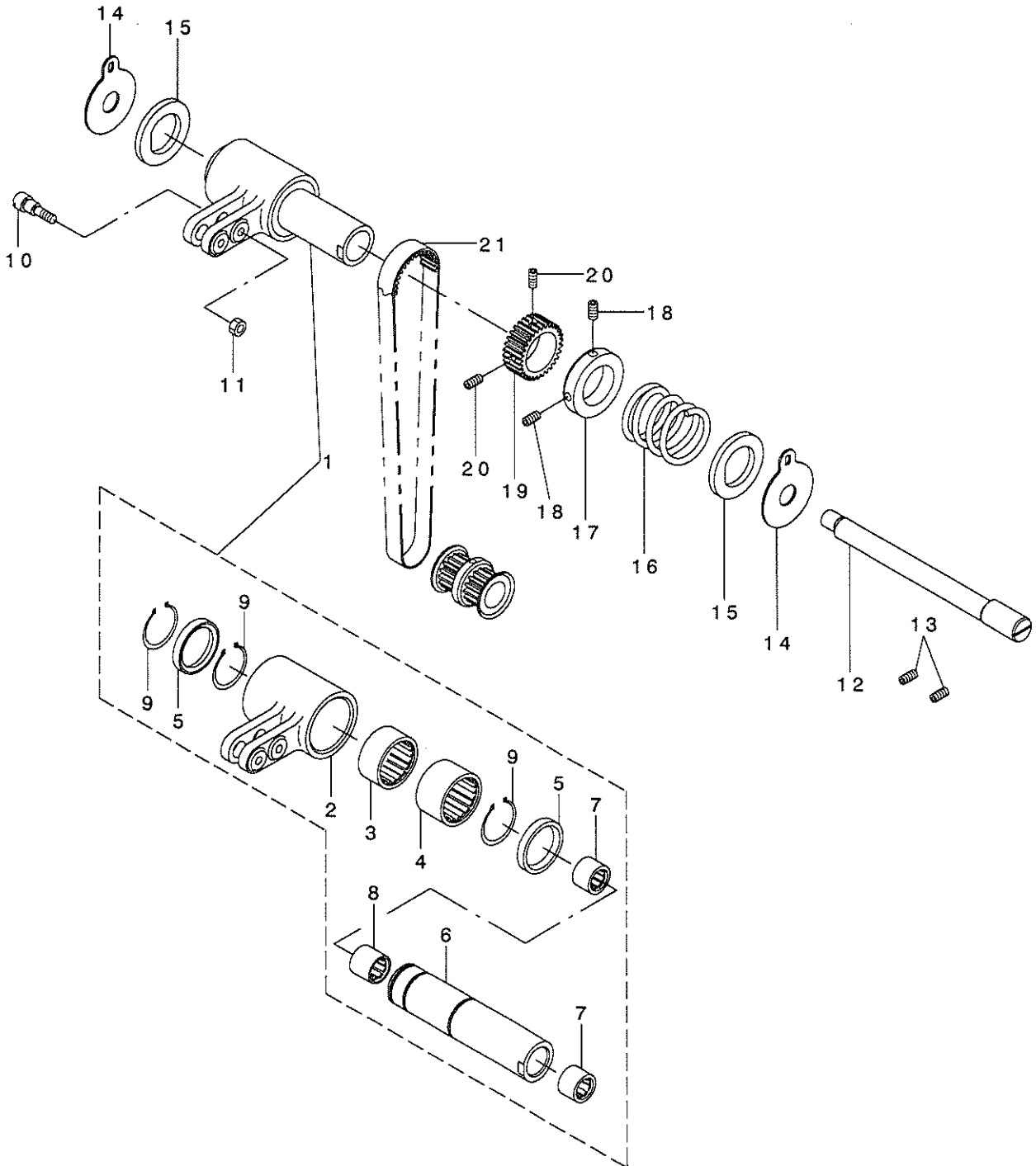

REF. NO	NOTE	PART NO.	DESCRIPTION	ヒョウメイ	Qty
1		MAV-045250A0	CLUTCH CASE ASM.	クラッチケース クミ	1
2		MAV-04525000	CLUTCH CASE	クラッチケース	(1)
3		SB-3200003-00	BALL BEARING	コロカ リジ クウケ	(1)
4		SB-3200004-00	BALL BEARING	コロカ リジ クウケ	(1)
5		MAV-04534000	CLUTCH OIL SHIEL	クラッチオイルシール	(2)
6		MAV-04526000	CLUTCH ROCKING SHAFT	クラッチヨウト ウジ ク	(1)
7		SB-3100003-00	BALL BEARING	コロカ リジ クウケ	(2)
8		SB-3100007-00	BALL BEARING	コロカ リジ クウケ	(1)
9		RC-1851217-KP	C-RING	Cカ タトメワ	(3)
10		SD-0600596-SH	STEP-SCREW	タメネジ	1
11		NM-6040003-SC	NUT M4	ワツカクナツト M4	1
12		MAV-04527000	CLUTCH SHAFT	クラッチシャフト	1
13		SM-8050602-TP	SCREW M5 L=6	トメネジ M5X0.8 L=6	2
14		MAV-04528000	BRAKE PLATE	ブ レーキイタ	2
15		MAV-04529000	BRAKE WASHER	ブ レーキワッシャ	2
16		MAV-04530000	BRAKE SPRING	ブ レーキハネ	1
17		MAV-04531000	CLUTCH BRAKE COLLER	クラッチブ レーキカラ	1
18		SM-8040602-TP	SCREW M4X0.7 L=6	トメネジ	2
19		MAV-04532000	CLUTCH PULLEY	クラッチブ ーリ	1
20		SM-8040302-TP	SETSCREW	トメネジ	2
21		MAV-04533000	CLUTCH TIMING BELT	クラッチタイミンク ハ ルト	1

# 4. ROLLER DRIVE COMPONENTS

ローラー駆動関係

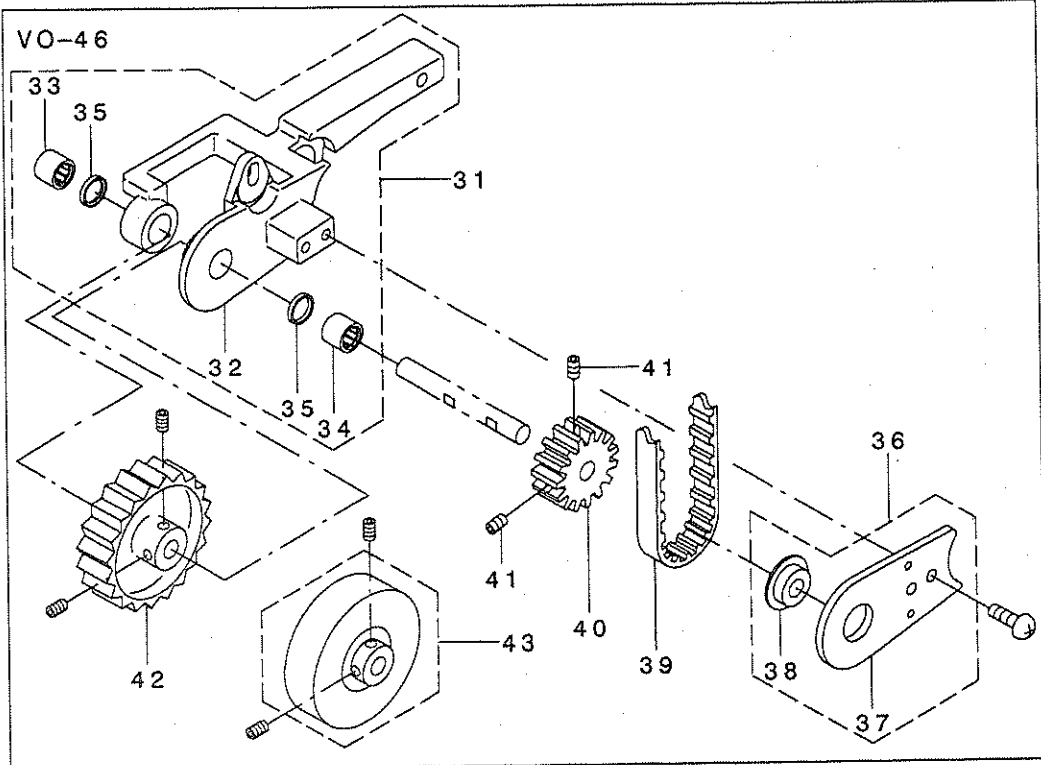
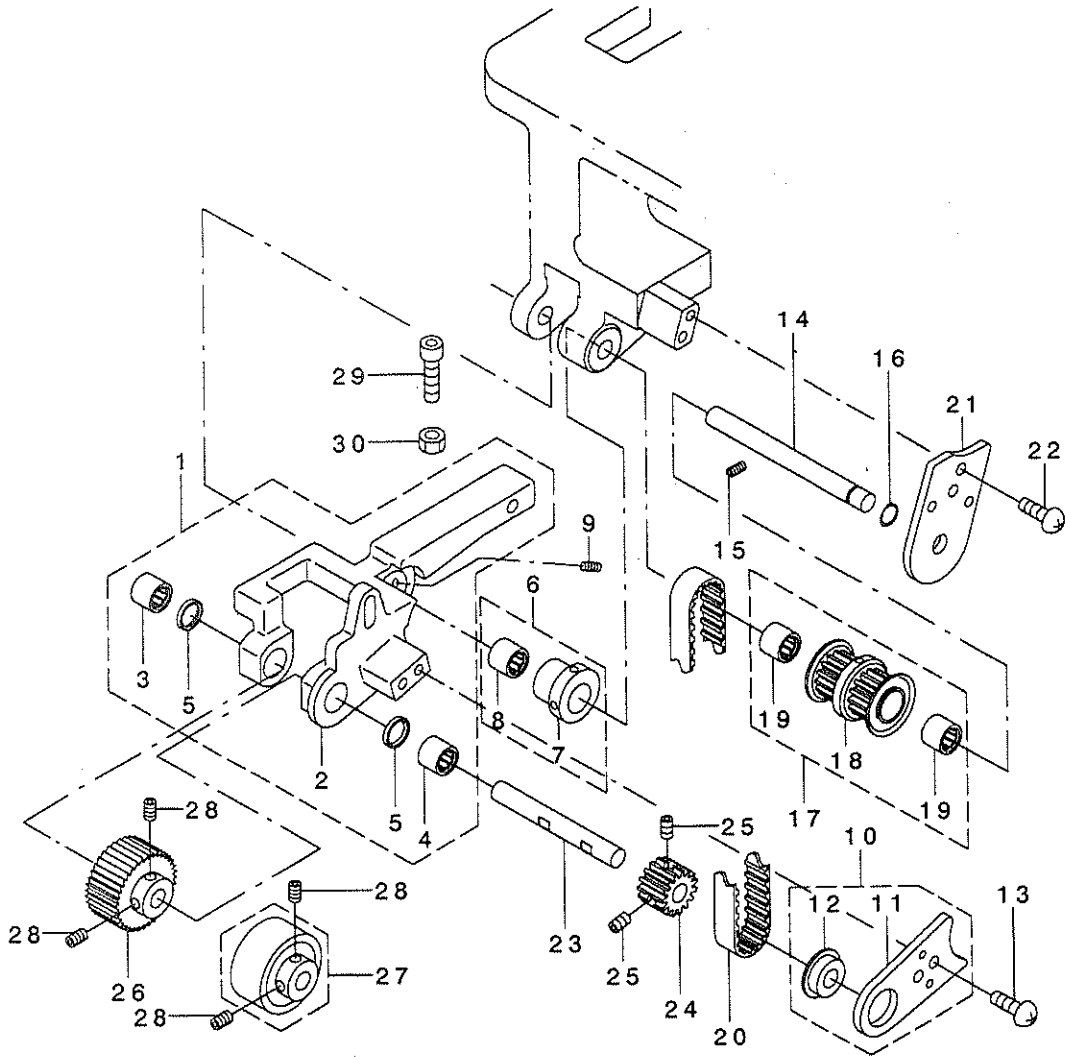



REF. NO	NOTE	PART NO.	DESCRIPTION	とよめい	Qty
1		MAV-045350A0	ROLLER BASE ASM.	ローラーハースクミ	1
2		MAV-04535000	ROLLER BASE	ローラーハース	(1)
3		SB-3070005-00	BEARING	コロカリシクウケ	(1)
4		SB-3070004-00	BEARING	コロカリシクウケ	(1)
5		MAV-04546000	ROLLER SHAFT OIL SHIEL	ローラーシャフトオイルシール	(2)
6		MAV-045360A0	ECCENTRIC COLLER ASM.	ローラーハースハンジシカラークミ	1
7		MAV-04536000	ROLLER BASE ECCENTRIC COLLER	ローラーハースハンジシカラークミ	(1)
8		SB-3070004-00	BEARING	コロカリシクウケ	(1)
9		SM-8040402-TP	SCREW M4X0.7 L=4	トメネジ M4X0.7 L=4	1
10		MAV-045470A0	ROLLER SHAFT PLATE ASM.	ローラーシャフトプレートクミ	1
11		MAV-04547000	ROLLER SHAFT PLATE	ローラーシャフトプレート	(1)
12		SB-1070001-00	BEARING	コロカリシクウケ	(1)
13		SM-6040802-TP	SCREW M4X0.7 L=8	ロツカクアナボルト	2
14		MAV-04537000	PULLEY SHAFT	プーリーシャフト	1
15		SM-8050502-TP	SCREW M5 L=5	トメネジ	2
16		RC-0650811-KP	RETAINING RING	Cカクタメワ	1
17		MAV-045380B0	INTERMEDIATE PULLEY ASM.	チュウカンフーリーソクミ	1
18		MAV-045380A0	INTERMEDIATE PULLEY ASM.	チュウカンフーリー(クミ)	(1)
19		SB-3070004-00	BEARING	コロカリシクウケ	(2)
20		MAV-04541000	ROLLER TIMING BELT	ローラータイミングハールト	1
21		MAV-04542000	SUPPORT PLATE	サポートプレート	1
22		SM-6040802-TP	SCREW M4X0.7 L=8	ロツカクアナボルト	2
23		MAV-04543000	ROLLER SHAFT	ローラーシャフト	1
24		MAV-04544000	ROLLER PULLEY	ローラーフーリー	1
25		SM-8040602-TP	SCREW M4X0.7 L=6	トメネジ	2
26	#01	MAV-04545000	STEEL ROLLER	スチールローラー(クサビカクタ)	1
27	#01	MAV-045500A0	URETHANE ROLLER ASM.	ウレタンローラー(クミ)	1
28		SM-8040402-TP	SCREW M4X0.7 L=4	トメネジ M4X0.7 L=4	2
29		SM-6062002-TP	SCREW M6 L=20	ロツカクアナボルト M6 L=20	1
30		NM-6060003-SC	NUT M6	ロツカクナツト M6	1
31		MAV-046350A0	ROLLER BASE ASM.	ローラーハースクミ	1
32		MAV-04635000	ROLLER BASE	ローラーハース	(1)
33		SB-3070005-00	BEARING	コロカリシクウケ	(1)
34		SB-3070004-00	BEARING	コロカリシクウケ	(1)
35		MAV-04546000	ROLLER SHAFT OIL SHIEL	ローラーシャフトオイルシール	(2)
36		MAV-046360A0	ROLLER SHAFT PLATE ASM.	ローラーシャフトプレートクミ	1
37		MAV-04636000	ROLLER SHAFT PLATE	ローラーシャフトプレート	(1)
38		SB-1070001-00	BEARING	コロカリシクウケ	(1)
39		MAV-04637000	ROLLER TIMING BELT	ローラータイミングハールト	1
40		MAV-04638000	ROLLER PULLY	ローラーフーリー	1
41		SM-8040802-TP	SCREW M4X8	トメネジ M4X0.7 L=8	2
42	#01	MAV-04640000	STEEL ROLLER	スチールローラーB	1
43	#01	MAV-046410A0	URETHANE ROLLER ASM.	ウレタンローラー(クミ)	1

NOTE (注記) #01...SELECTIVE PART

選択部品

5. PRESSER COMPONENTS (V045 MODEL)

押さえ関係 (V045仕様)

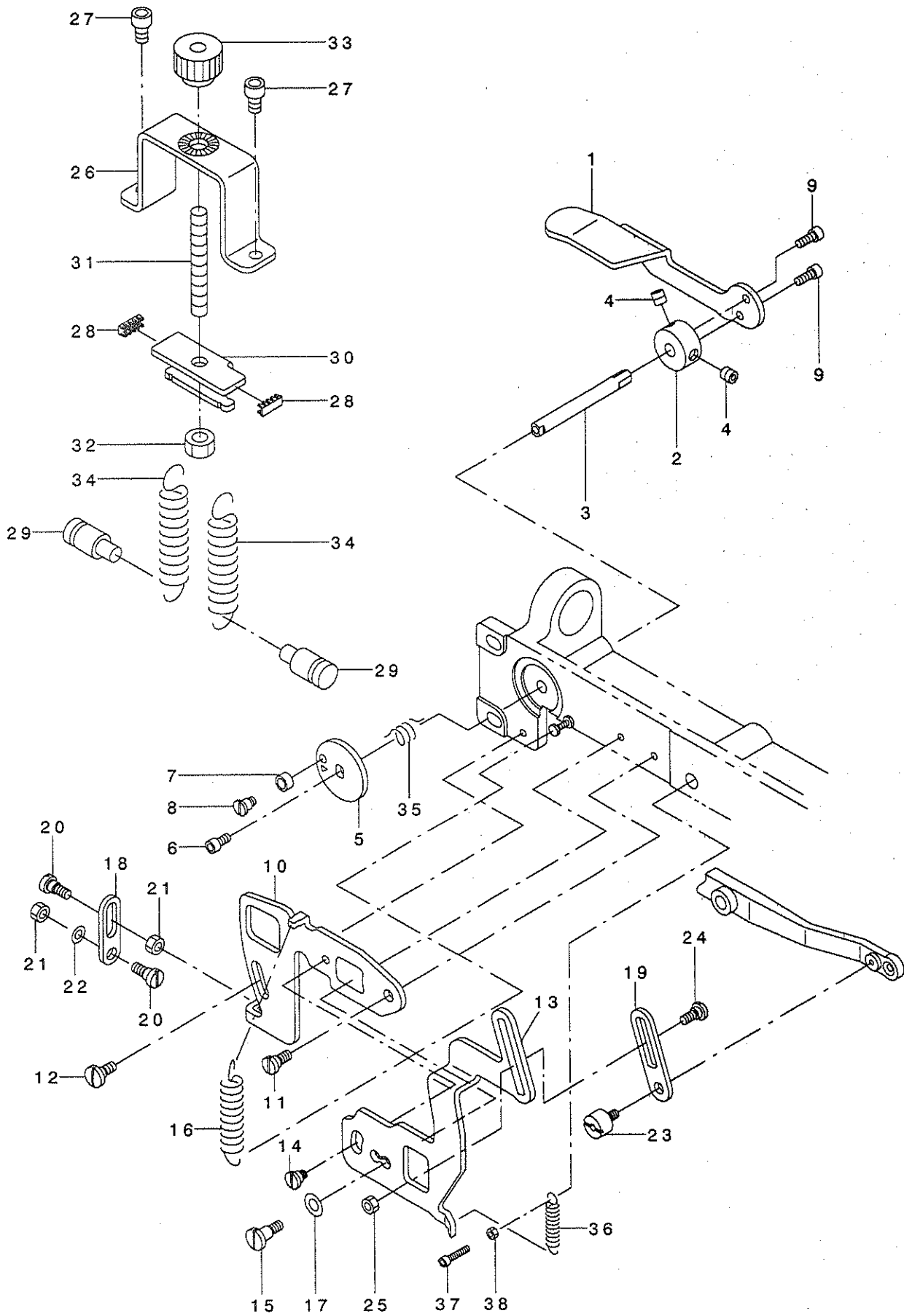

REF. NO	NOTE	PART NO.	DESCRIPTION	品名	Qty
1		MAV-04555000	PRESSER LIFTING LEVER	オサエアケレハ-	1
2		MAV-04556000	PRESSER LIFTING LEVER COLLER	オサエアケレハ-カラ-	1
3		MAV-04557000	PRESSER LIFTING SHAFT	オサエアケシク	1
4		SM-8060602-TP	SCREW M6X6	トメネシ M6 L=6	2
5		MAV-04558000	PRESSER LIFTING CAM PLATE	オサエアケカムイタ	1
6		SM-6040802-TP	SCREW M4X0.7 L=8	ロツカクアナホルト	1
7		D2587-L8W-B00	ROLLER	クト-カムコロ	1
8		SD-0550451-SP	HINGE SCREW	タネネシ	1
9		SM-6041002-TP	SCREW M4 L=10	ロツカクアナホルト M4X0.7 L=10	2
10		MAV-04559000	PRESSER LIFTING PLATE	オサエアケプレート	1
11		SD-0640325-SP	HINGE SCREW	タネネシ	1
12		SD-0600361-SP	HINGE SCREW D=6 H=3.6	タネネシ D=6 H=3.6	1
13		MAV-04560000	PRESSER LIFTING JOINT PLATE	オサエアケジョイントプレート	1
14		SD-0640321-TP	HINGE SCREW D=6.35 H=3.2	タネネシ D=6.35 H=3.2	1
15		SD-0640751-SP	HINGE SCREW D= 6.35 H= 7.5	タネネシ D=6.35 H=7.5	1
16		B2056-781-000	BLOCKING ARM SPRING	ソソウテハネ	1
17		WP-0651056-SH	WASHER 6.5X11X1	ヒラサガネ 6.5X11X1	1
18		MAV-04561000	PRESSER LIFTING ROD	オサエアケロッド	1
19		MAV-04616000	PRESSER LIFTING LINK	オサエアケリンク	1
20		SD-0600402-TP	HINGE SCREW D= 6 H= 4	タネネシ D=6 H=4	2
21		NS-6620310-SP	NUT 3/16-32	ロツカクナツト 3/16-32	2
22		WP-0480856-SP	WASHER 4.8X8.4X0.8	ヒラサガネ 4.8X8.4X0.8	1
23		MAV-04562000	KNEE LIFTER LEVER COLLER	ヒサアケテコカラ-	1
24		SD-0600271-SP	HINGE SCREW D= 6 H= 2.7	タネネシ D=6 H=2.7	1
25		NS-6110430-SP	NUT 11/64-40	ロツカクナツト 11/64-40	1
26		MAV-04564000	PRESSER LIFTING BASE	オサエアケベース	1
27		SM-6061002-TP	SCREW M6 L=10	ロツカクアナホルト M6 L=10	2
28		MAV-04565000	SPRING PLATE COVER	ハネプレートカバー	2
29		B1506-352-000	TENSION SPRING RACK B	ヒツハリハネカケB	2
30		MAV-04566000	SPRING PLATE	ハネプレート	1
31		MAV-04567000	PRESSER ADJUSTING SCREW	オサエチヨウセツネシ	1
32		NM-6080001-SC	NUT M8X1.25	ロツカクナツト M8 1シユ	1
33		MAV-04568000	PRESSER ADJUSTING KNOB	オサエチヨウセツツマミ	1
34		MAV-04569000	PRESSER SPRING	オサエハネ	2
35		MAV-04563000	PRESSER LIFTING LEVER SPRING	オサエアケレハ-ハネ	1
36		135-15606	SPRING	イトキリホシヨカモトシハネ	1
37		SM-6031402-TP	SCREW	ロツカクアナホルト	1
38		NM-6030003-SC	NUT M3	ロツカクナツト M3	1

## 6. PRESSER COMPONENTS (V046 MODEL)

押さえ関係 (V046仕様)

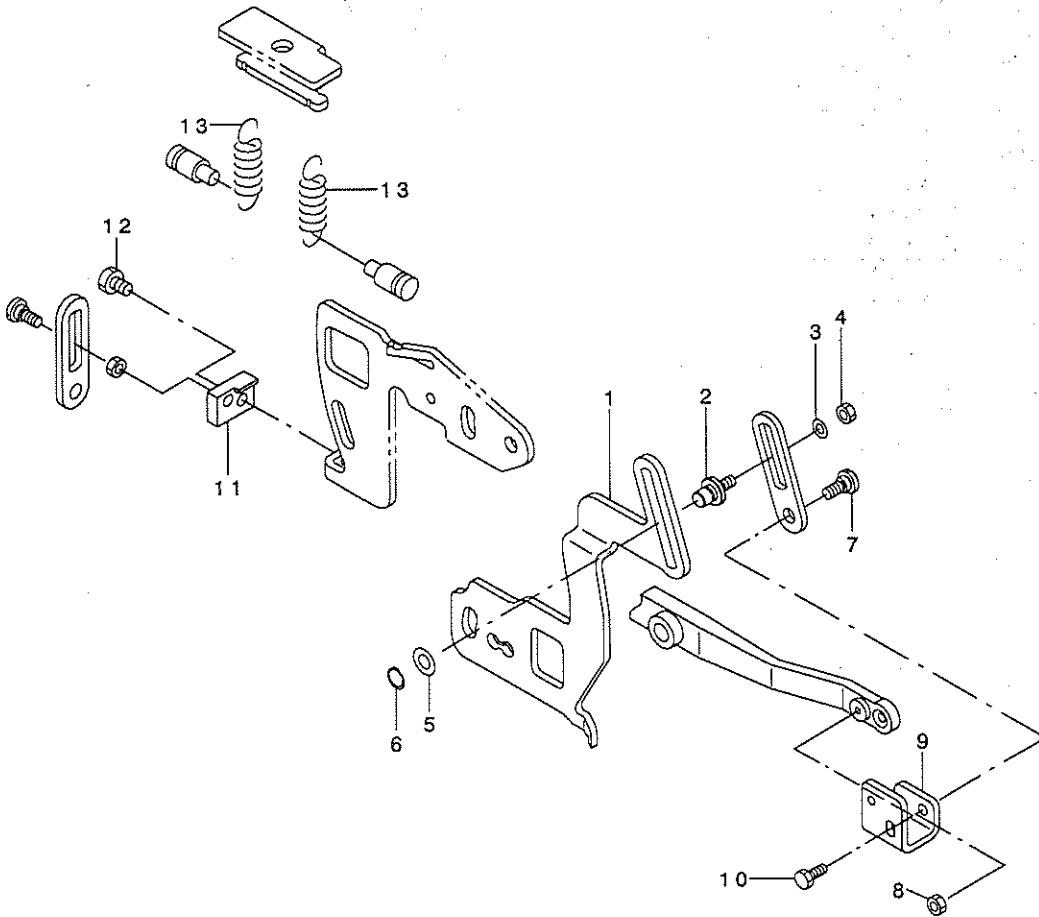

REF. NO	NOTE	PART NO.	DESCRIPTION	ヒョウメイ	Qty
1		MAV-04615000	LIFTING PRESSER JOINT PLATE	オサエアケ ショイントプレート	1
2		MAV-04617000	LIFTING PRESSER LINK PIN	オサエアケ リンクピン	1
3		WP-0430800-SC	WASHER M4	ヒラサ カネ コガ タマル M4	1
4		NM-6040001-SC	NUT M4	ロツカクナツト M4	1
5		WP-0651056-SH	WASHER 6.5X11X1	ヒラサ カネ 6.5X11X1	1
6		RC-0560711-KP	RETAINING RING	Cカ タトメワ	1
7		SD-0600271-SP	HINGE SCREW D=6 H= 2.7	タソネシ D=6 H=2.7	1
8		NS-6110350-SP	NUT 11/64-40	ロツカクナツト 11/64-40	1
9		MAV-04618000	LEVER BRACKET	テコア ラケット	1
10		SS-9090823-TP	BOLT 9/64-40 L=8	ロツカクボルト	1
11		MAV-04655000	CONNECTING BLOCK	オサエアケ セツウ クコマ	1
12		SS-6620730-SP	SCREW 3/16-32 L= 7.0	ヒラネシ 3/16-32 L=7	1
13		MAV-04656000	PRESSER SPRING	オサエハネ	2

7. LOWER ROLLER COMPONENTS (V046 MODEL)

下ローラー関係 (V046仕様)

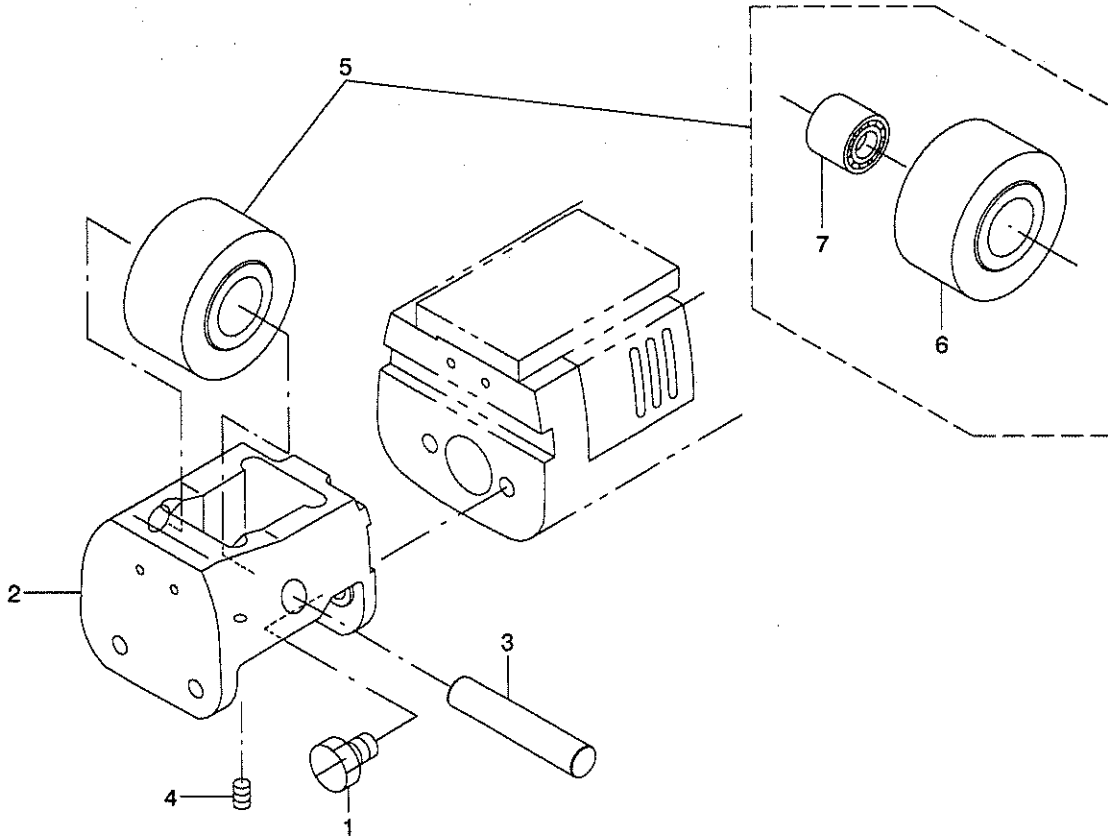

REF. NO	NOTE	PART NO.	DESCRIPTION	ヒョウメイ	Qty
1		SS-9120910-TP	SCREW 3/16-28 L=9	ロツカクネ ルト 3/16-28 L=9	2
2		MAV-04620000	LOWER ROLLER BASE	シタローラーターイ	1
3		MAV-04623000	LOWER ROLLER SHAFT	シタローラーシャフト	1
4		SM-8040602-TP	SCREW M4X0.7 L=6	トメネジ	1
5		MAV-046210B0	LOWER ROLLER COMPL.	シタローラーソウクミ	1
6		MAV-046210A0	LOWER ROLLER ASM.	シタローラー (クミ)	(1)
7		GBR-01174000-A	NEEDLE BEARING	ニートルハアリング	(1)

8. EXCHANGING PARTS AT USING VO45 UNIT (FOR MS-1190 · 1190M)

V045取付時の交換部品 (MS-1190 · 1190M用)

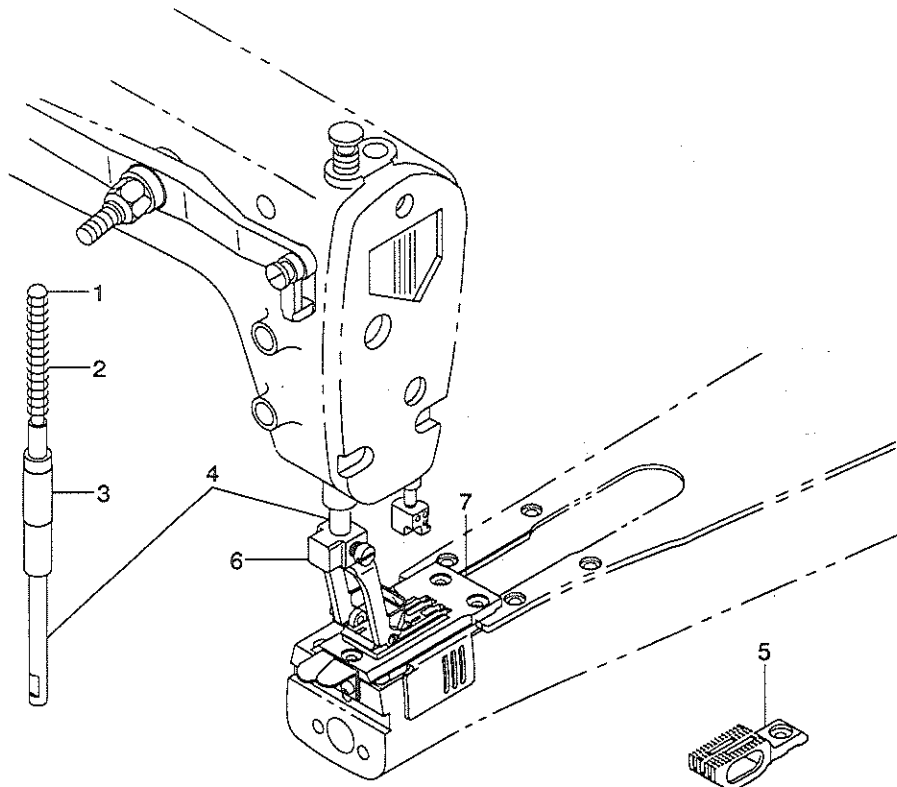

REF. NO	NOTE	PART NO.	DESCRIPTION	キ ャ ン 名 義	Qty
1		MAV-01510000	PRESSER GUIDE BAR	オサエ アソナイホ	1
2		MAV-01511000	SPRING	オサエ チヨセツハネ	1
3		MAV-01512000-A	BUSHING, LOWER	オサエホ -ツタメタル	1
4		MAV-04580000	V0-45 PRESSER BAR	V0-45 オサエホウ	1
5	#01	MAV-04593000	V0-45 FEED DOG	V0-45 オクリ	1
6	#01	MAV-04583CB0	PRESSER FOOT ASM. 3/16"	V0-45オサエ 3/16(クミ)エシユツヨウ	1
7	#01	MAV-04572C00	V0-45 THROAT PLATE (3/16)	V0-45 ハリタ (3/16)	1

NOTE (注記) #01.....REFER TO THE TABLE OF 13A-シの交換部品一覧表を  
EXCHANGING PARTS ON PAGE 13 ご参照ください。

9. EXCHANGING PARTS AT USING VO45 UNIT (FOR MS-1261 · 1260 · 1261M)

VO45取付時の交換部品 (MS-1261 · 1260 · 1261M用)

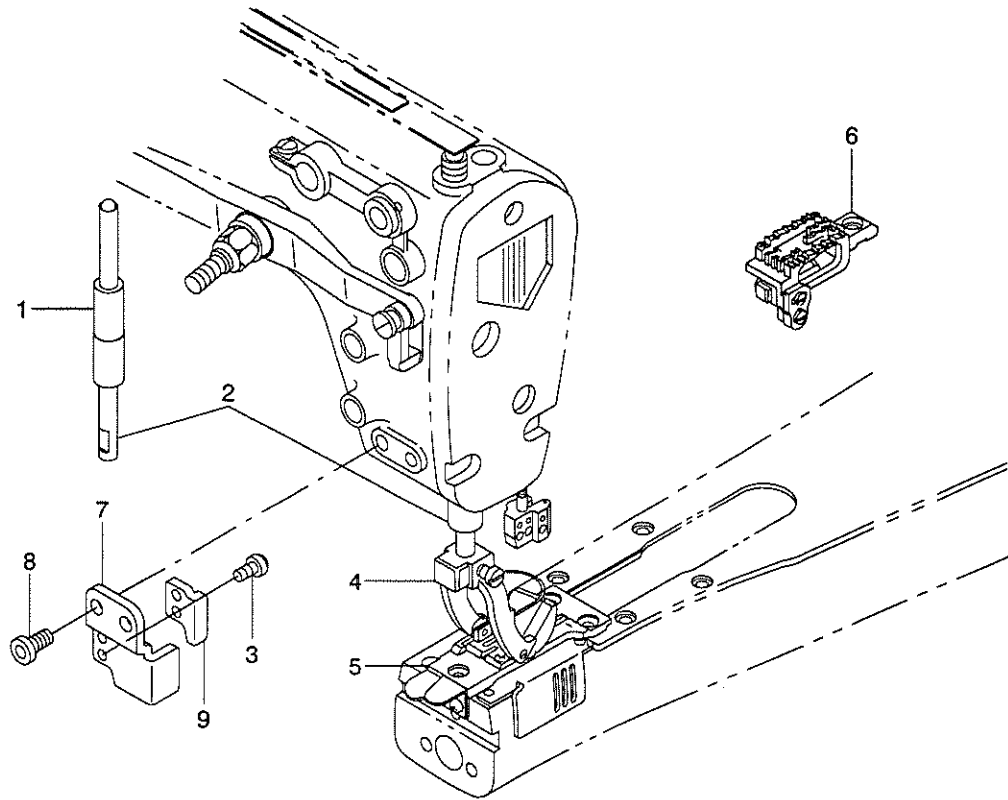

REF. NO.	NOTE	PART NO.	DESCRIPTION	品名	Qty
1		129-58609	BUSHING, LOWER	オサエホウ ウタメタル	1
2		129-58559	PRESSER BAR ASM.	オサエホウ ウ (クミ)	1
3		SS-7110910-TP	SCREW 11/64-40 L= 8.5	マルヒラネシ 11/64-40 L=8.5	2
4	#01	129-60068	PRESSER 1/4" (ASM) EXPORT	オサエ 1/4" (クミ) ヌシユツヨウ	1
5	#01	129-53204	THROAT PLATE XH (1/4")	ハリイタ XH(1/4")	1
6	#01	129-63351	FEED DOG XH(1/4") ASM.	オクリハ XH(1/4") (クミ)	1
7		129-59300	PRESSER FOOT GUIDE (A)	オサエアツカ イト (A)	1
8		SM-6061202-TP	SCREW M6 L=12	ロツカクアホ ルト M6 L=12	2
9		129-59409	PRESSER FOOT GUIDE (B)	オサエアツカ イト (B)	1

NOTE (注記) #01.....REFER TO THE TABLE OF 14ページの交換部品一覧表を  
EXCHANGING PARTS ON PAGE 14 ご参照ください。

10. TABLE OF V045 EXCHANGING GAUGE PARTS (FOR MS-1190 · 1190M)

V045 交換ゲージ一覧表 (MS-1190 · 1190M用)

FOR MS-1190

MS-1190用

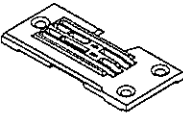
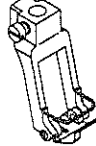
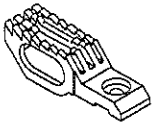
			1	2	3	4	5
Description 品名			Gauge set	Gauge set (with finger guard)	V045 Throat plate	V045 Presser foot asm. (with finger guard)	V045 Feed dog
			ゲージセット	ゲージセット (指ガード付)	V045 針板	V045 押え(組) (指ガード付)	V045 送り歯
Needle gauge size 針番			/	/			
Code ゲージ 記号	inch	mm					
B	1/8	3.2	MAV04570AA0	MAV04570AB0	MAV04570A00	MAV04581AB0	MAV04593000
C	5/32	4.0	MAV04571BA0	MAV04571BB0	MAV04571B00	MAV04582BB0	↑
D	3/16	4.8	MAV04572CA0	MAV04572CB0	MAV04572C00	MAV04583CB0	↑
E	7/32	5.6	MAV04573DA0	MAV04573DB0	MAV04573D00	MAV04584DB0	↑
F	1/4	6.4	MAV04574EA0	MAV04574EB0	MAV04574E00	MAV04585EB0	MAV04594000

FOR MS-1190M

MS-1190M用

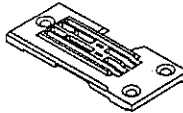
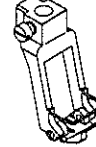
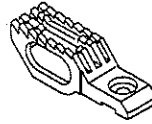
			1	2	3	4	5
Description 品名			Gauge set	Gauge set (with finger guard)	V045 Throat plate	V045 Presser foot asm. (with finger guard)	V045 Feed dog
			ゲージセット	ゲージセット (指ガード付)	V045 針板	V045 押え(組) (指ガード付)	V045 送り歯
Needle gauge size 針番			/	/			
Code ゲージ 記号	inch	mm					
B	1/8	3.2	MAV04575AA0	MAV04575AB0	MAV04575A00	MAV04586AB0	MAV04595000
C	5/32	4.0	MAV04576BA0	MAV04576BB0	MAV04576B00	MAV04587BB0	↑
D	3/16	4.8	MAV04577CA0	MAV04577CB0	MAV04577C00	MAV04588CB0	↑
E	7/32	5.6	MAV04578DA0	MAV04578DB0	MAV04578D00	MAV04589DB0	↑
F	1/4	6.4	MAV04579EA0	MAV04579EB0	MAV04579E00	MAV04590EB0	MAV04596000



11. TABLE OF V045 EXCHANGING GAUGE PARTS (FOR MS-1261 · 1260 · 1261M)

V045 交換ゲージ一覧表 (MS-1261 · 1260 · 1261M 用)

FOR MS-1261  
MS-1261 用

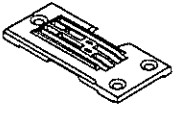
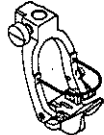
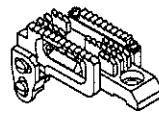
Description 品名			1	2	3	4	5
			Gauge set	Gauge set (with finger guard)	Throat plate	Presser foot asm. (with finger guard)	Feed dog asm.
Needle gauge size 針幅							
Code ゲージ 記号	inch	mm					
E	7/32	5.6	MAV04570ECO	MAV04570EDO	12953303	12960167	12963450
F	1/4	6.4	MAV04570FCO	MAV04570FDO	12953204	12960068	12963351
G	9/32	7.2	MAV04570GCO	MAV04570GDO	12953402	12960266	12963559
H	5/16	8.0	MAV04570HCO	MAV04570HDO	12953501	12960365	12963658
K	3/8	9.5	MAV04570KCO	MAV04570KDO	12953600	12960464	12963757

FOR MS-1260 · 1261M  
MS-1260 · 1261M 用

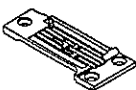
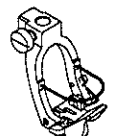
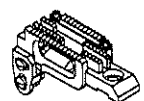
Description 品名			1	2	3	4	5	
			Gauge set	Gauge set (with finger guard)	Throat plate	Presser foot asm. (with finger guard)	Feed dog asm.	
Needle gauge size 針幅								
Code ゲージ 記号	inch	mm						
MS-1260	D	3/16	4.8	MAV04572DCO	MAV04572DDO	12977906	12978268	12978755
	E	7/32	5.6	MAV04571ECO	MAV04571EDO	12972907	12960183	12975058
MS-1261M	F	1/4	6.4	MAV04571FCO	MAV04571FDO	12972808	12960084	12974952
	G	9/32	7.2	MAV04571GCO	MAV04571GDO	12973004	12960282	12975157
	H	5/16	8.0	MAV04571HCO	MAV04571HDO	12973103	12960381	12975256
	K	3/8	9.5	MAV04571KCO	MAV04571KDO	12973202	12960480	12975355

NUMERICAL INDEX OF PARTS

索引

PART NO 品番	PAGE 頁	REF NO	PART NO 品番	PAGE 頁	REF NO	PART NO 品番	PAGE 頁	REF NO	PART NO 品番	PAGE 頁	REF NO
B1506-352-000	8	29	MAV-04593000	11	5	SM-6031402-TP	8	37			
B2056-781-000	8	16	MAV-04603000	1	20	SM-6040802-TP	6	13			
			MAV-04607000	1	21	SM-6040802-TP	6	22			
CS-1201010-SH	2	3	MAV-04610000	2	12	SM-6040802-TP	8	6			
			MAV-04611000	1	19	SM-6041002-TP	8	9			
D2587-L8W-B00	8	7	MAV-04615000	9	1	SM-6061002-TP	8	27			
			MAV-04616000	8	19	SM-6061202-TP	12	8			
GBR-01174000-A	10	7	MAV-04617000	9	2	SM-6061602-TP	2	20			
			MAV-04618000	9	9	SM-6061602-TP	2	24			
MAV-01510000	11	1	MAV-04620000	10	2	SM-6062002-TP	1	3			
MAV-01511000	11	2	MAV-046210A0	10	6	SM-6062002-TP	6	29			
MAV-01512000-A	11	3	MAV-046210B0	10	5	SM-8040302-TP	4	20			
MAV-04501000	1	1	MAV-04623000	10	3	SM-8040402-TP	6	9			
MAV-04502000	1	2	MAV-046350A0	6	31	SM-8040402-TP	6	28			
MAV-04503000	1	7	MAV-04635000	6	32	SM-8040602-TP	4	18			
MAV-04504000	1	9	MAV-046360A0	6	36	SM-8040602-TP	6	25			
MAV-04505000	1	15	MAV-04636000	6	37	SM-8040602-TP	10	4			
MAV-04506000	1	16	MAV-04637000	6	39	SM-8040802-TP	6	41			
MAV-04507000	1	18	MAV-04638000	6	40	SM-8050502-TP	6	15			
MAV-04515000	2	1	MAV-04640000	6	42	SM-8050602-TP	4	13			
MAV-045160B0	2	7	MAV-046410A0	6	43	SM-8060602-TP	2	11			
MAV-04516000	2	8	MAV-04655000	9	11	SM-8060602-TP	8	4			
MAV-04517000	2	9	MAV-04656000	9	13	SM-8082502-TP	2	18			
MAV-045180A0	2	14				SM-9061850-SC	1	5			
MAV-04518000	2	15	NM-6030003-SC	1	14	SS-6620730-SP	9	12			
MAV-04519000	2	19	NM-6030003-SC	8	38	SS-7110910-TP	12	3			
MAV-04520000	2	23	NM-6040001-SC	9	4	SS-9090823-TP	9	10			
MAV-045210A0	2	25	NM-6040003-SC	4	11	SS-9120910-TP	10	1			
MAV-04521000	2	26	NM-6060003-SC	2	22						
MAV-04522000	2	30	NM-6060003-SC	6	30	WP-0430800-SC	9	3			
MAV-045250A0	4	1	NM-6080001-SC	8	32	WP-0480856-SP	8	22			
MAV-04525000	4	2	NM-6080003-SC	2	17	WP-0641600-SC	1	4			
MAV-04526000	4	6	NS-6110350-SP	9	8	WP-0641600-SC	1	6			
MAV-04527000	4	12	NS-6110430-SP	8	25	WP-0641600-SC	2	29			
MAV-04528000	4	14	NS-6620310-SP	8	21	WP-0651056-SH	8	17			
MAV-04529000	4	15				WP-0651056-SH	9	5			
MAV-04530000	4	16	PS-0300102-K0	1	12	WP-1221016-SP	2	6			
MAV-04531000	4	17	PS-0300242-K0	1	11	WZ-1200200-KP	2	13			
MAV-04532000	4	19									
MAV-04533000	4	21	RC-0560711-KP	9	6	129-53204	12	5			
MAV-04534000	4	5	RC-0650811-KP	6	16	129-58559	12	2			
MAV-045350A0	6	1	RC-1200001-KP	2	5	129-58609	12	1			
MAV-04535000	6	2	RC-1851217-KP	4	9	129-59300	12	7			
MAV-045360A0	6	6				129-59409	12	9			
MAV-04536000	6	7	SB-1060002-00	2	27	129-60068	12	4			
MAV-04537000	6	14	SB-1070001-00	6	12	129-63351	12	6			
MAV-045380A0	6	18	SB-1070001-00	6	38	135-15606	8	36			
MAV-045380B0	6	17	SB-1080006-00	2	16						
MAV-04541000	6	20	SB-1120005-00	2	4						
MAV-04542000	6	21	SB-1350003-00	2	10						
MAV-04543000	6	23	SB-2120001-00	2	2						
MAV-04544000	6	24	SB-3070004-00	6	4						
MAV-04545000	6	26	SB-3070004-00	6	8						
MAV-04546000	6	5	SB-3070004-00	6	19						
MAV-04546000	6	35	SB-3070004-00	6	34						
MAV-045470A0	6	10	SB-3070005-00	6	3						
MAV-04547000	6	11	SB-3070005-00	6	33						
MAV-045500A0	6	27	SB-3100003-00	4	7						
MAV-04555000	8	1	SB-3100007-00	4	8						
MAV-04556000	8	2	SB-3200003-00	4	3						
MAV-04557000	8	3	SB-3200004-00	4	4						
MAV-04558000	8	5	SD-0550451-SP	8	8						
MAV-04559000	8	10	SD-0600271-SP	8	24						
MAV-04560000	8	13	SD-0600271-SP	9	7						
MAV-04561000	8	18	SD-0600361-SP	8	12						
MAV-04562000	8	23	SD-0600402-TP	8	20						
MAV-04563000	8	35	SD-0600596-SH	4	10						
MAV-04564000	8	26	SD-0600756-TP	2	28						
MAV-04565000	8	28	SD-0640321-TP	8	14						
MAV-04566000	8	30	SD-0640325-SP	8	11						
MAV-04567000	8	31	SD-0640751-SP	8	15						
MAV-04568000	8	33	SD-0801606-SH	2	21						
MAV-04569000	8	34	SM-5030355-SE	1	8						
MAV-04572C00	11	7	SM-5040655-SN	1	10						
MAV-04580000	11	4	SM-5040655-SN	1	17						
MAV-04583CB0	11	6	SM-6031202-TP	1	13						



**JUKI®**

JUKI CORPORATION

JUKI 株式会社

お買い求め、ご相談は  
To order or for further  
information,  
please contact:

※このパーツリストは商品改良のため予告なく変更する事があります。

※ The description covered in this parts list is subject to change for improvement of the commodity without notice.

※このパーツリストは、1996年10月現在の商品仕様で編集したものです。

※ This parts list is edited in accordance with the product specifications as of October 1996.