

DC SERIES

MODELS: DC-1S. DC-3.

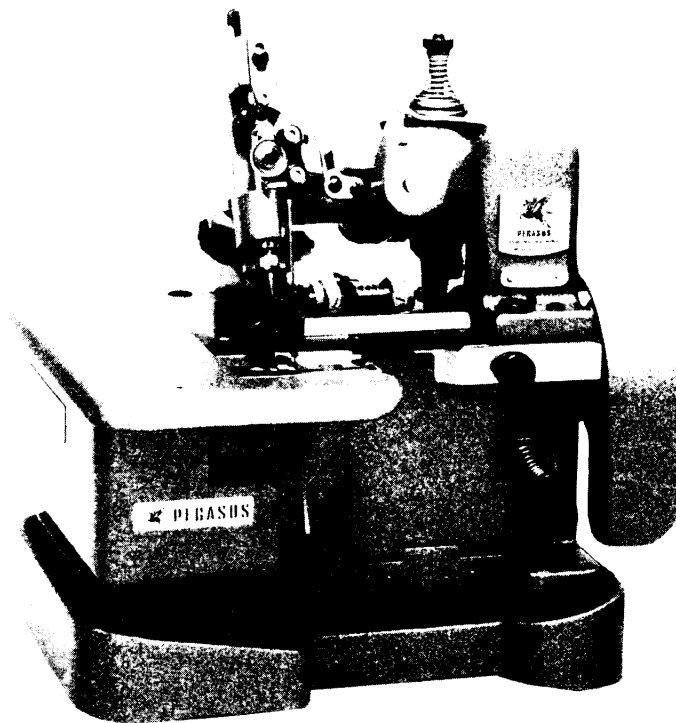

PEGASUS[®]

IN ORDERING PARTS

This list has been arranged to simplify ordering repair parts for model DC-1S and model DC-3.

Various sections of the mechanisms are shown on each page. On the page opposite the illustrations will be found a listing of the parts with their reference numbers, parts numbers, names and the number of pieces required.

At the back of this list, a numerical index of all parts is shown. This will facilitate locating the illustration and descriptions when only the part number is known.

In ordering parts from this list, USE ONLY the PART NUMBER in the second column. Reference number should never be used in ordering parts.

This Parts List applied to the machines manufactured in April, 1979 and is applicable to your machine subject to change without notice.

パーツ・リスト ご利用に際して

本パーツ・リストは、DC-1S形及びDC-3形の修理用部品を容易にご利用いただけるよう編集されています。

機構別に各頁に収録され、部品図解の反対頁には、参照番号、部品番号、名称、使用数量の順に記載されています。

本パーツ・リストの18頁には、部品番号索引表を記載しています。部品番号のみで、その図解、名称等が容易に引出せます。

本パーツ・リストに基づき、部品ご注文の場合、参照番号は絶対に使用せず、必ず部品番号のみを明示して下さい。

本パーツ・リストは、1979年4月現在製造中のマシンを基に作成しています。

本パーツ・リストに記載された部品番号、部品形状等は、設計変更により、変る場合があります。

CONTENTS

MECHINE FRAME & CRANKSHAFT MECHANISM.....
NEEDLE DRIVE MECHANISM.....
LOOPER DRIVE MECHANISM.....
FEED MECHANISM.....
UPPER & LOWER KNIFE MECHANISM.....
PRESSER FOOT & LIFTING MECHANISM.....
CLOTH PLATE & MISCELLANEOUS COVERS.....
ACCESSORIES.....
NUMERICAL INDEX OF PARTS.....

目次

	PAGE 頁
アーム・ベッド主軸機構.....	2~3
針棒機構.....	4~5
大・小ルーパー機構.....	6~7
送り機構.....	8~9
上・下メス機構.....	10~11
押エ機構.....	12~13
カバー・外装機構.....	14~15
付属品.....	16~17
部品番号索引.....	18

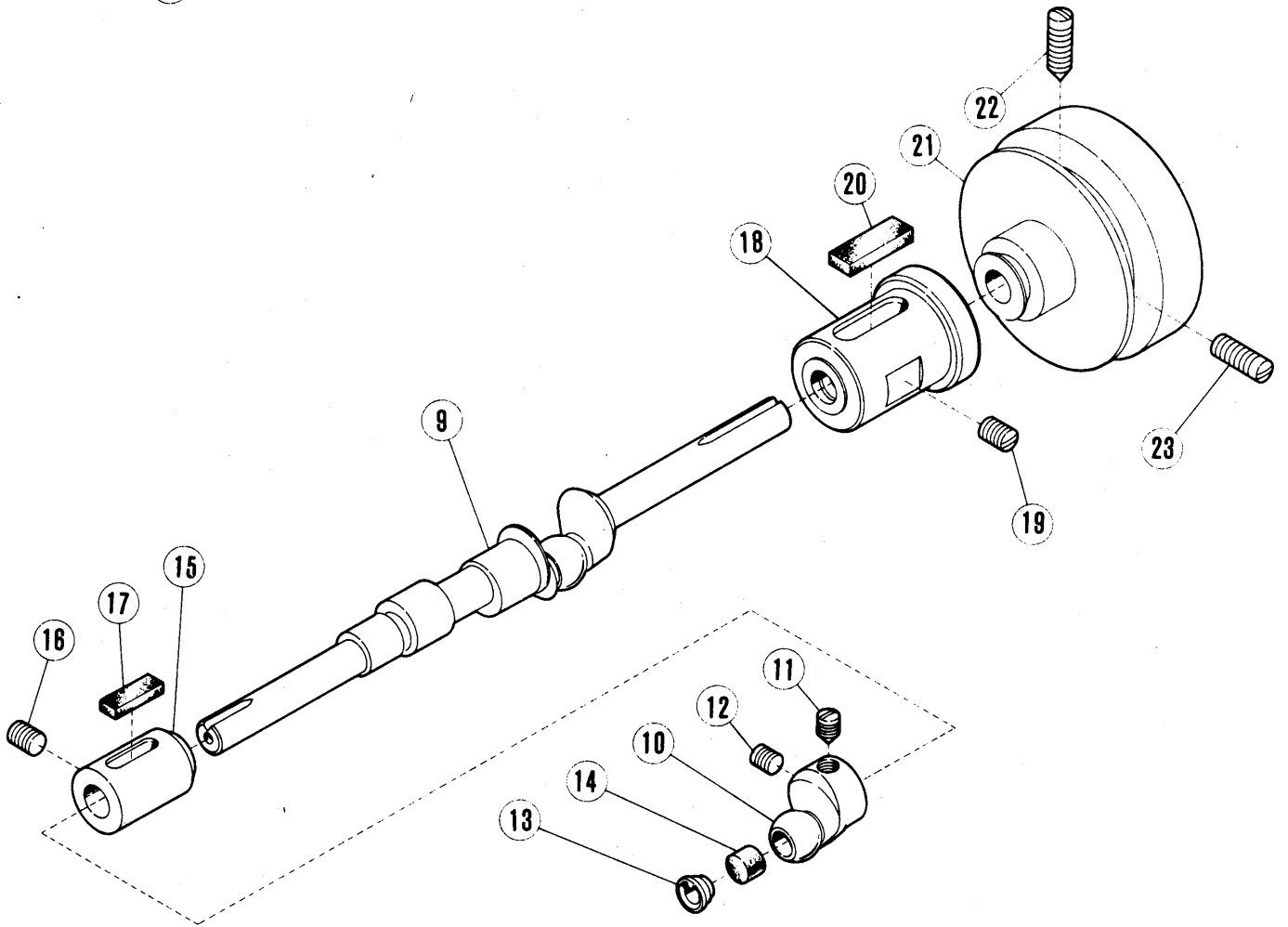
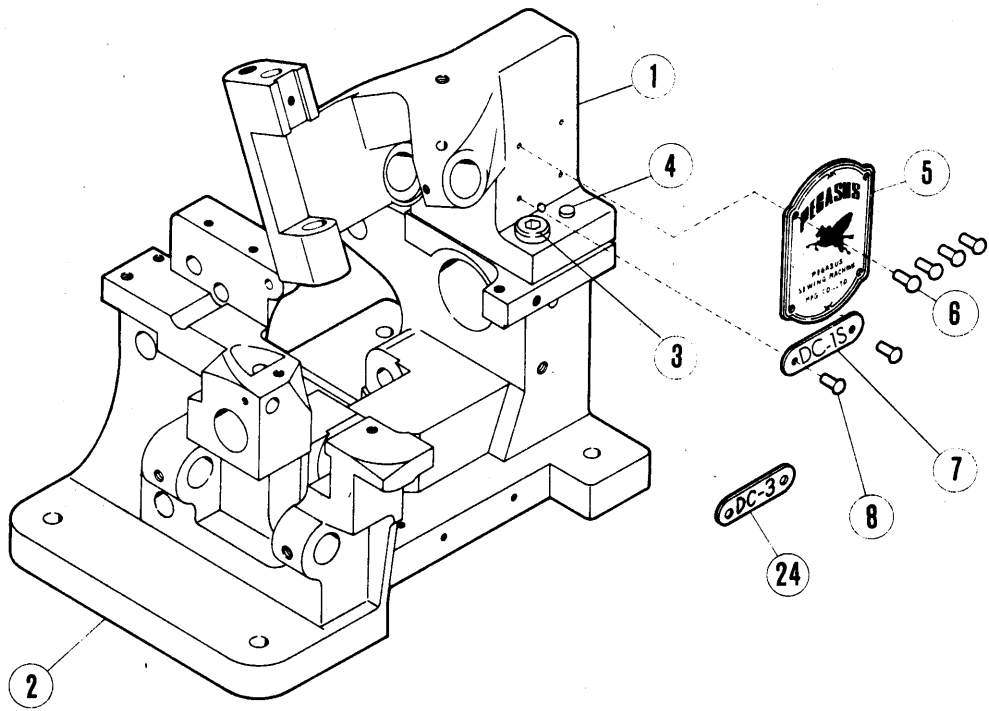

MACHINE FRAME & CRANKSHAFT MECHANISM

アーム・ベッド主軸機構

Ref. No. 参照番号	Parts No. 部品番号	Name	名称	Qt. 数量
1	137002	Arm	アーム	1
2	137003A	Bed	ベッド	1
3	1936A	Arm-bed screw	アーム締付ネジ	2
4	137950	" taper pin	アームベッドテーパーピン	2
5	202046	Name plate	銘板	1
6	137011W	" " pin	〃 止ピン	4
7	149023	Model plate	型式板	1
8	137011W	" " pin	〃 止ピン	2
9	200674A	Crankshaft	クランクシャフト	1
10	137202	Looper drive crank	エキセンクランク	1
11	2368	" " " spot screw	〃 止ネジ(先有)	1
12	2022	" " " set screw	〃 〃 (先無)	1
13	200607	" " " oil cap	〃 油栓	1
14	200389	" " " " wick	〃 給油フェルト	1
15	137205	Crankshaft bushing	小ブッシュ	1
16	2022-3	" " screw	〃 止ネジ	1
17	200334	" " oil wick	〃 給油フェルト	1
18	137206A	" flanged bushing	大ブッシュ	1
19	2022-3	" " " screw	〃 止ネジ	1
20	200335	" " " oil wick	〃 給油フェルト	1
21	137204	Drive pulley	プーリー	1
22	5052	" " spot screw	〃 止ネジ(先有)	1
23	5051	" " set screw	〃 〃 (先無)	1
24	139019W	Model plate	形式板	1

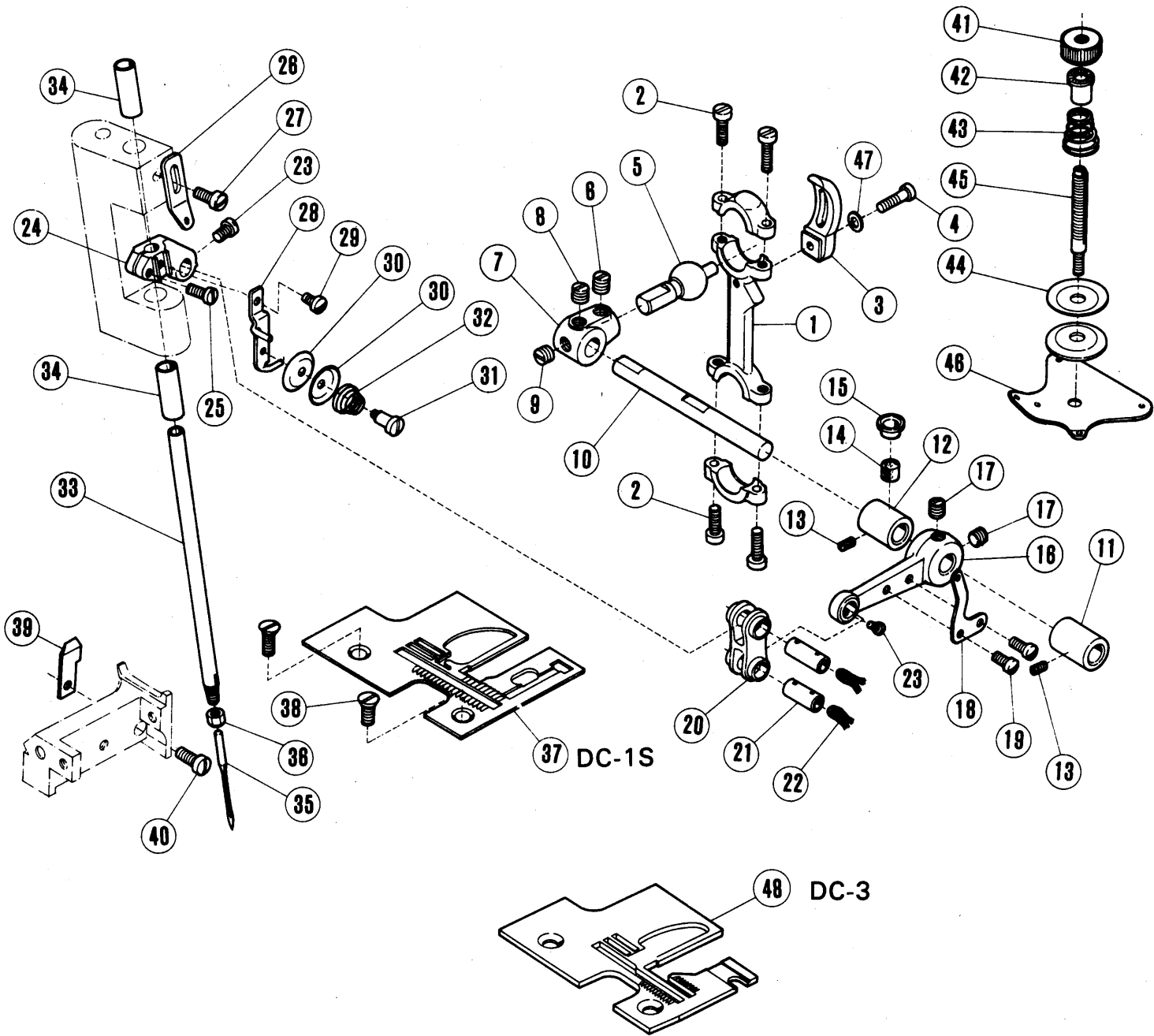

NEEDLE DRIVE MECHANISM

針 棒 機 構

Ref. No. 参照番号	Parts No. 部品番号	Name	名 称	Qt. 数量
1	137120	Needle bar drive connection	大ロッド	1
2	2213-1	" " " " cap screw	◇ 蓋止ネジ	4
3	137130	" " " " guide	◇ 振り止メ	1
4	5010	" " " " " screw	◇ ◇ 止ネジ	1
5	137121	" " " " ball stud	針棒後クランク球	1
6	2022	" " " " " " set screw	◇ ◇ 止ネジ	1
7	137127	" " " " arm (rear)	針棒後クランク	1
8	2913-1	" " " " (") set screw (short)	◇ ◇ 止ネジ(前)	1
9	2022	" " " " (") " " (long)	◇ ◇ ◇ (後)	1
10	137128	" " " " pivot shaft	◇ クランク軸	1
11	200037	" " " " " " bushing (front)	◇ ◇ ブッシュ(前)	1
12	202010	" " " " " " " " (rear)	◇ ◇ ◇ (後)	1
13	1457	" " " " " " " " screw	◇ ◇ ◇ 止ネジ	2
14	200389	" " " " " " " oil wick	◇ ◇ 給油フェルト	1
15	200607	" " " " " " " " cap	◇ ◇ 油栓	1
16	200652	" " " " " (front)	◇ 前クランク	1
17	5385	" " " " " (") set screw	◇ ◇ 止ネジ	2
18	137102	" thread take-up	上糸振り糸道	1
19	1196	" " " " screw	◇ 止ネジ	2
20	200653	" bar drive link	針棒リンク	1
21	200654	" " " " " pin	◇ ピン	2
22	202177	" " " " " " oil wick	◇ ◇ 給油紐	2
23	1222	" " " " " " screw	◇ ◇ 止ネジ	2
24	200655	" " clamp	針棒抱キ	1
25	1170-3	" " " " screw	◇ 止ネジ	1
26	137101	" thread guide	上糸道	1
27	1216	" " " " screw	◇ 止ネジ	1
28	137107	Secondary needle thread tension plate	小調子台	1
29	1186	" " " " " " " screw	◇ ◇ 止ネジ	1
30	137108	" " " " " " disc	◇ 皿	2
31	1092	" " " " " post	◇ ◇ 止ネジ	1
32	137109	" " " " " " spring	◇ バネ	1
33	137122	Needle bar, complete with 137122-1 & 3119	針棒(組) 137122-1, 3119ノ組	1
34	137123A	" " bushing	◇ ブッシュ	2
35	DC×1	Needle, size No. 9 (for domestics) or No. 11 (for exports)	針 #9 (国内用) ◇ #11 (貿易用)	1
36	3119	" clamp nut	針止メナット	1
37	137135A	" plate	針板	1
38	1732	" " screw	◇ 止ネジ	2
39	137564	" guard	針受	1
40	1170-1	" " " " screw	◇ 止ネジ	1
41	3056	Primary needle thread tension nut	針糸調子ナット	1
42	101113	" " " " " " spring bushing	◇ ◇ 止パイプ	1
43	137113	" " " " " " spring (heavy)	◇ バネ(強)	1
44	210319	" " " " " " disc	◇ 皿	2
45	1817-2A	" " " " " " post	◇ 棒	1
46	137105	" " " " " " plate	上糸調子台	1
47	200821	Washer	座金	1
48	139135	Needle plate	針板	1

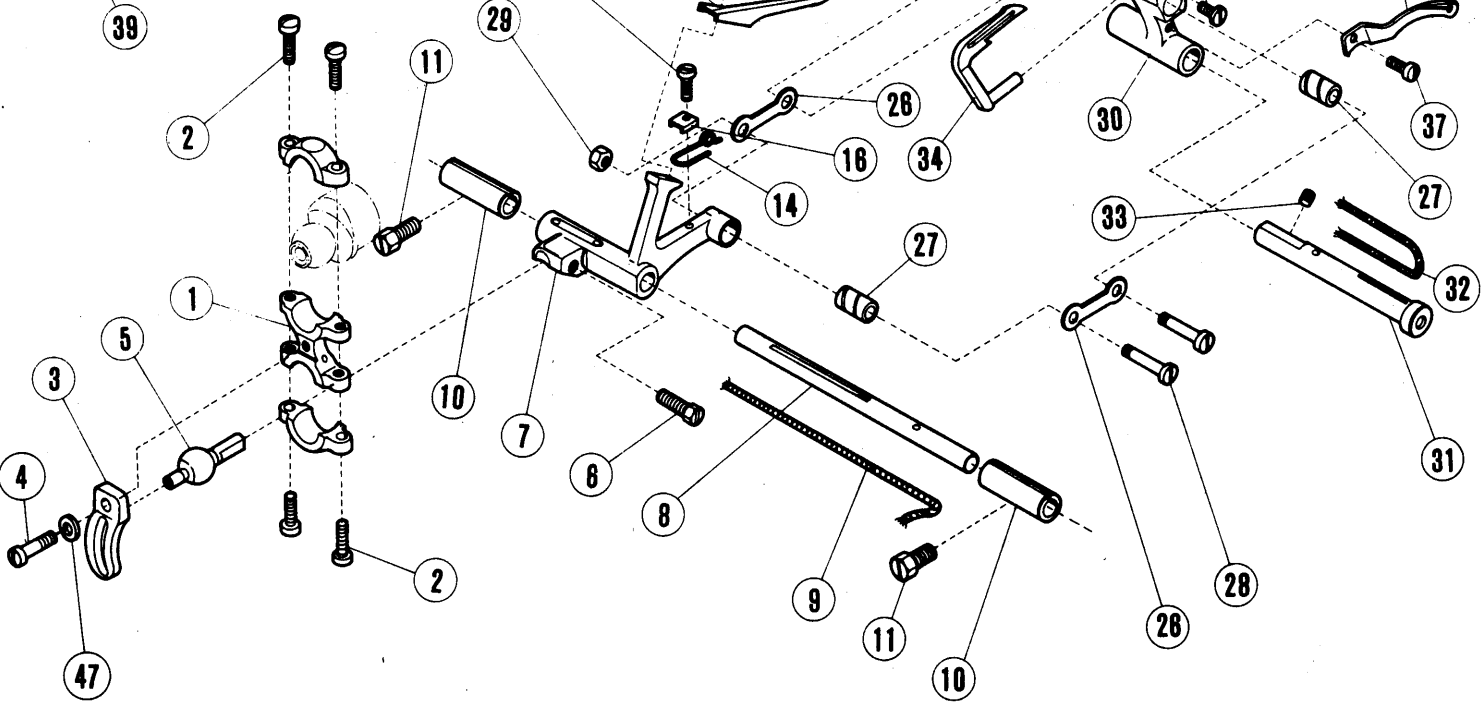
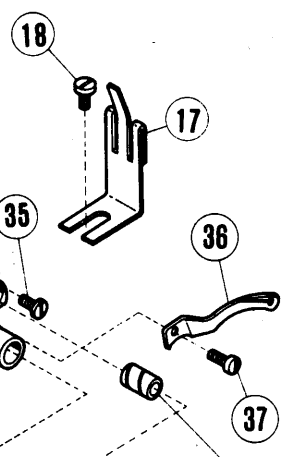
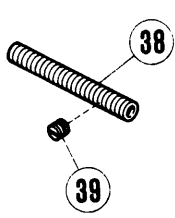
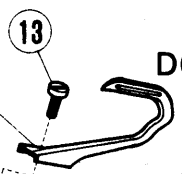
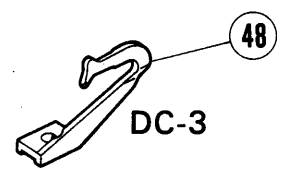
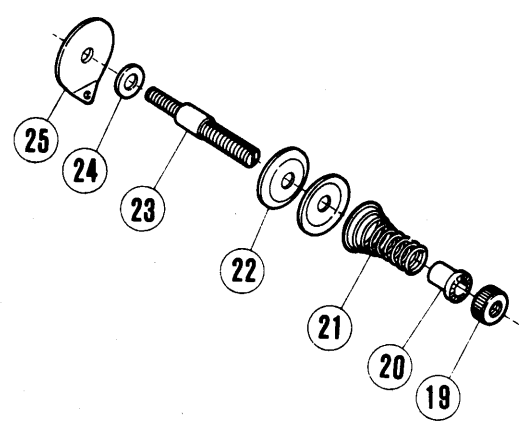
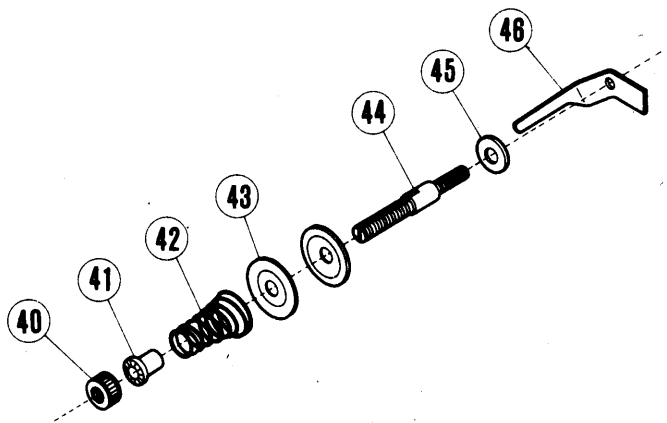

LOOPER DRIVE MECHANISM
大 小 ル ー パ ー 機 構

Ref. No. 参照番号	Parts No. 部品番号	Name	名 称	Qt. 数量
1	137311	Looper drive connection	小ロッド	1
2	2213-1	" " " cap screw	〃 蓋止ネジ	4
3	137130	" " " guide	〃 振り止メ	1
4	5010	" " " " screw	〃 〃 止ネジ	1
5	137121	" " " ball stud	〃 球	1
6	2022-4	" " " " " screw	〃 〃 止ネジ	1
7	200619	Right looper lever	大ルーパー台	1
8	200620	" " " shaft	〃 ピン	1
9	202176	" " " " oil wick	〃 〃 給油紐	1
10	137409	" " " " split bushing	割ブッシュ	2
11	2022-4	" " " " " " screw	〃 止ネジ	2
12	137301	" looper	大ルーパー	1
13	1196	" " screw	〃 止ネジ	1
14	137307A	Left looper thread guide	〃 台糸道	1
15	2922	" " " " " screw	〃 〃 止ネジ	1
16	200947	" " " " " washer	〃 〃 押エ金	1
17	137104	Right looper thread guide	三又糸道	1
18	1216	" " " " " screw	〃 止ネジ	1
19	3056	" " " " tension nut	前糸調子ナット	1
20	101113	" " " " " spring bushing	〃 〃 止パイプ	1
21	137115	" " " " " spring (medium)	〃 バネ(中)	1
22	210319	" " " " " disc	〃 皿	2
23	1817-2A	" " " " " post	〃 棒	1
24	137142	" " " " " " washer	〃 〃 座金	1
25	137106	" " " " " plate	〃 台	1
26	200621A	Looper drive link	ルーパーリンク	2
27	200622A	" " " " " bushing	〃 ブッシュ	2
28	200623A	" " " " " screw	〃 締付ネジ	2
29	3044	" " " " " " nut	〃 〃 ナット	2
30	200624	Left looper lever	小ルーパー台	1
31	200625	" " " " " shaft	〃 ピン	1
32	202176	" " " " " oil wick	〃 〃 給油紐	1
33	2022-3	" " " " " screw	〃 〃 止ネジ	1
34	137302	" looper	小ルーパー	1
35	5053	" " " " " screw	〃 止ネジ	1
36	137308	Right looper thread take-up	大ルーパー糸道	1
37	1196	" " " " " " screw	〃 止ネジ	1
38	137103	Left looper thread tube	糸道パイプ	1
39	1457-1	" " " " " " screw	〃 止ネジ	1
40	3056	" " " " " tension nut	裏糸調子ナット	1
41	101113	" " " " " " spring bushing	〃 〃 止パイプ	1
42	137114	" " " " " " spring (light)	〃 バネ(弱)	1
43	210319	" " " " " " disc	〃 皿	2
44	1817-2A	" " " " " " post	〃 棒	1
45	137142	" " " " " " " washer	〃 〃 座金	1
46	137016	" " " " " " plate	〃 台	1
47	200821	Washer	座金	1
48	139301	Spreader	大ルーパー(2本系用)	1

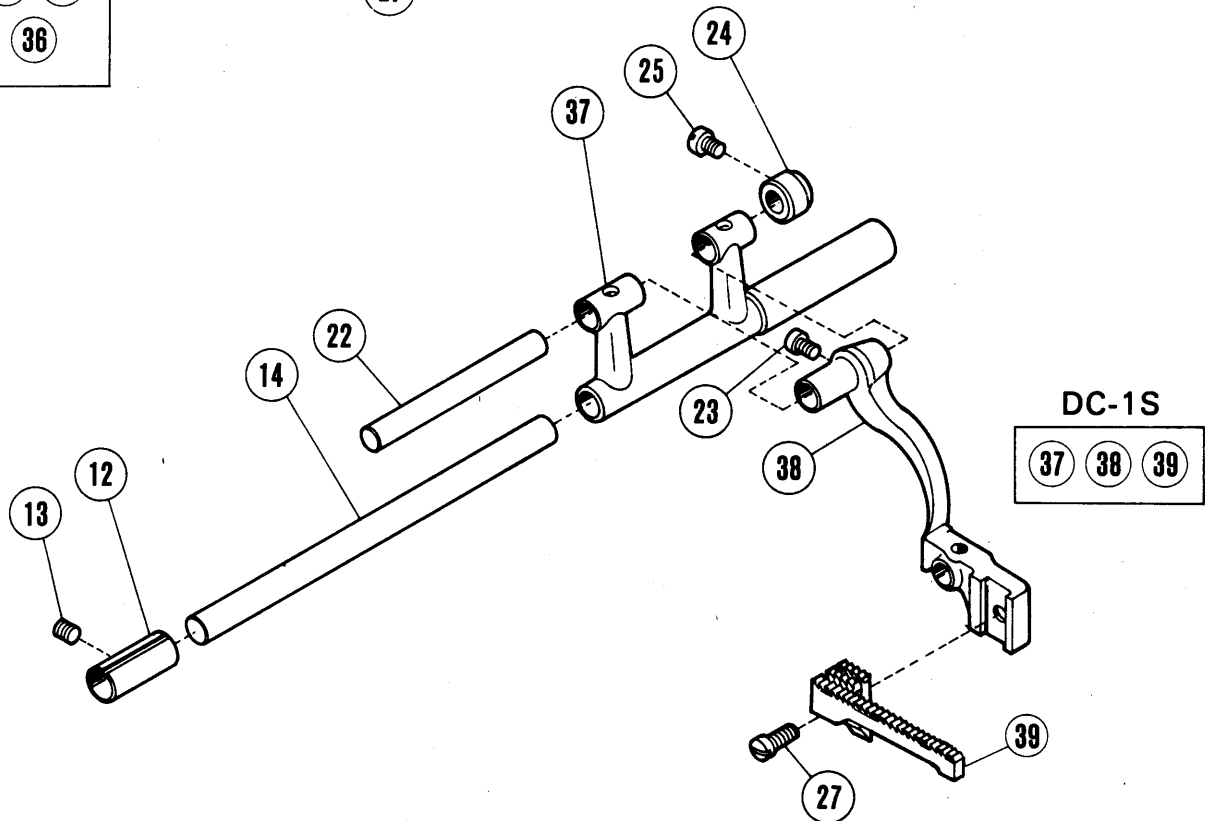
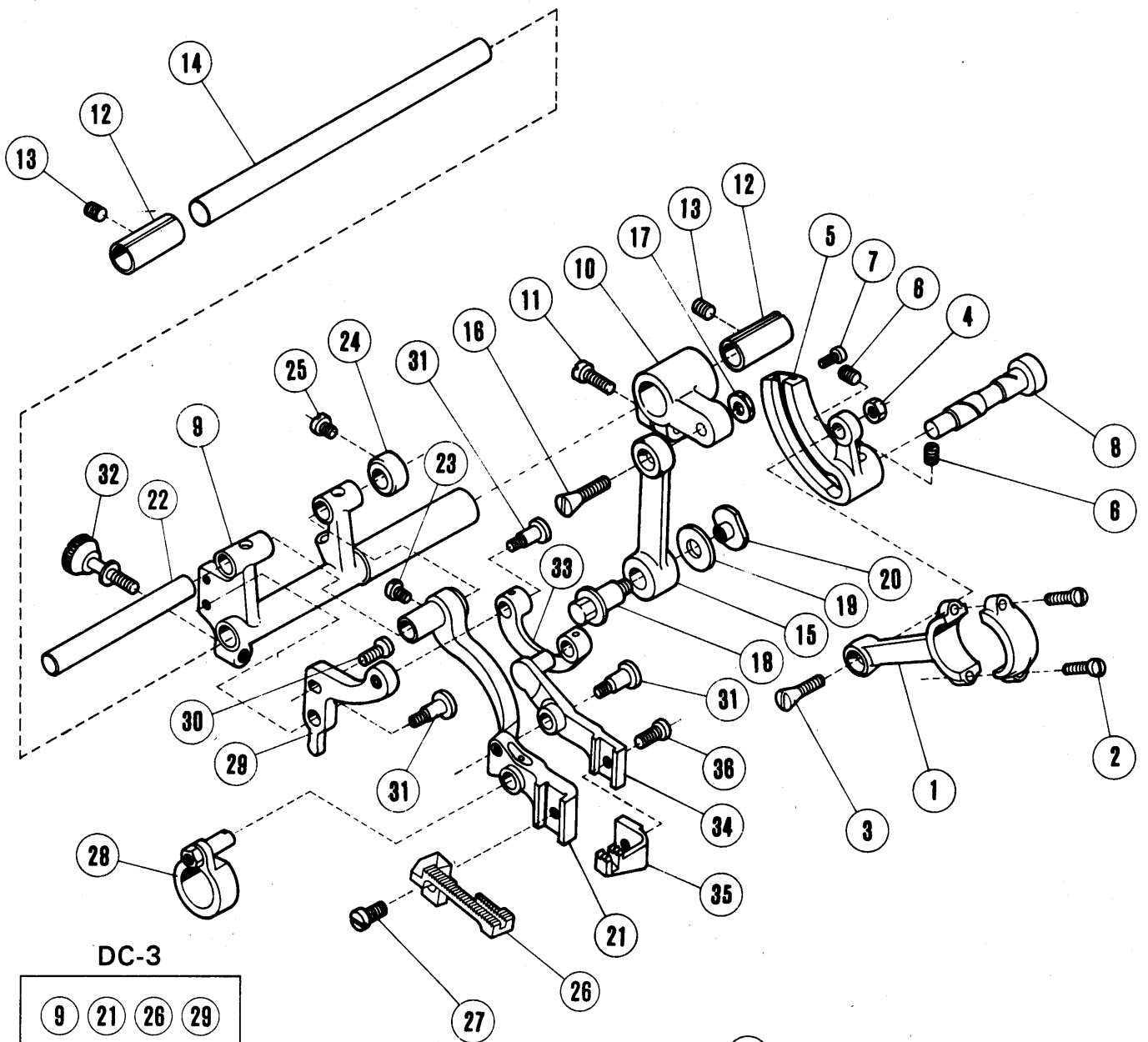

FEED MECHANISM

送 り 機 構

Ref. No. 参照番号	Parts No. 部品番号	Name	名 称	Qt. 数量
1	137418A	Feed bar drive connection	送りロッド	1
2	5002	" " " " cap screw	〃 蓋止ネジ	2
3	2366	" drive segment stud	〃 テーパーネジ	1
4	3018	" " " " nut	〃 〃 ナット	1
5	137403	" " segment	大送り調節器	1
6	2022-3	" " " set screw	〃 止ネジ	2
7	2922	" " " stop screw	送り調節ストップネジ	1
8	137404	" " " pivot shaft	大送り調節器ピン	1
9	137402	" rocker	送りロックシャフト	1
10	137408	" " drive arm	〃 抱キ	1
11	1156	" " " " screw	〃 〃 止ネジ	1
12	137409	" bar rocker shaft split bushing	割ブッシュ	2
13	2022-3	" " " " " " screw	〃 止ネジ	2
14	137417	" " " pivot shaft	送り台シャフト	1
15	137440	Stitch length adjusting connection	送り調節杆	1
16	2366	" " " " drive stud	〃 テーパーネジ	1
17	3018	" " " " " " nut	〃 〃 ナット	1
18	137420	" " " stud	〃 段ネジ	1
19	137441	" " " " washer	〃 〃 座金	1
20	137421	" " " " nut	〃 〃 ナット	1
21	137415	Main feed bar	大送り取付台	1
22	137442	Feed bar drive shaft	〃 ピン	1
23	2237	" " set screw	〃 〃 止ネジ	1
24	198053	" " drive shaft collar	〃 〃 カラー	1
25	5053	" " " " " screw	〃 〃 〃 止ネジ	1
26	137455	Main feed dog	大送り歯	1
27	1175-2	" " " screw	〃 止ネジ	1
28	137411	Feed lift connection	送り上下ダルマ 200628, 200629トノ組	1
29	137405	Auxiliary feed height adjusting lever	小送り調節器	1
30	1175-3	" " " " " clamp screw	〃 止ネジ	1
31	1060	" " lever pivot stud	送り装置ネジ	3
32	2425	" " height adjusting screw	小送り調節ネジ	1
33	137406	" " " " link	〃 リンク	1
34	137416	" " lever	〃 取付台	1
35	137456	" " dog	〃 歯	1
36	1202	" " " screw	〃 〃 止ネジ	1
37	140402	Feed rocker	送りロックシャフト	1
38	202088	Feed bar	送り取付台	1
39	149022	Feed dog	送り歯	1

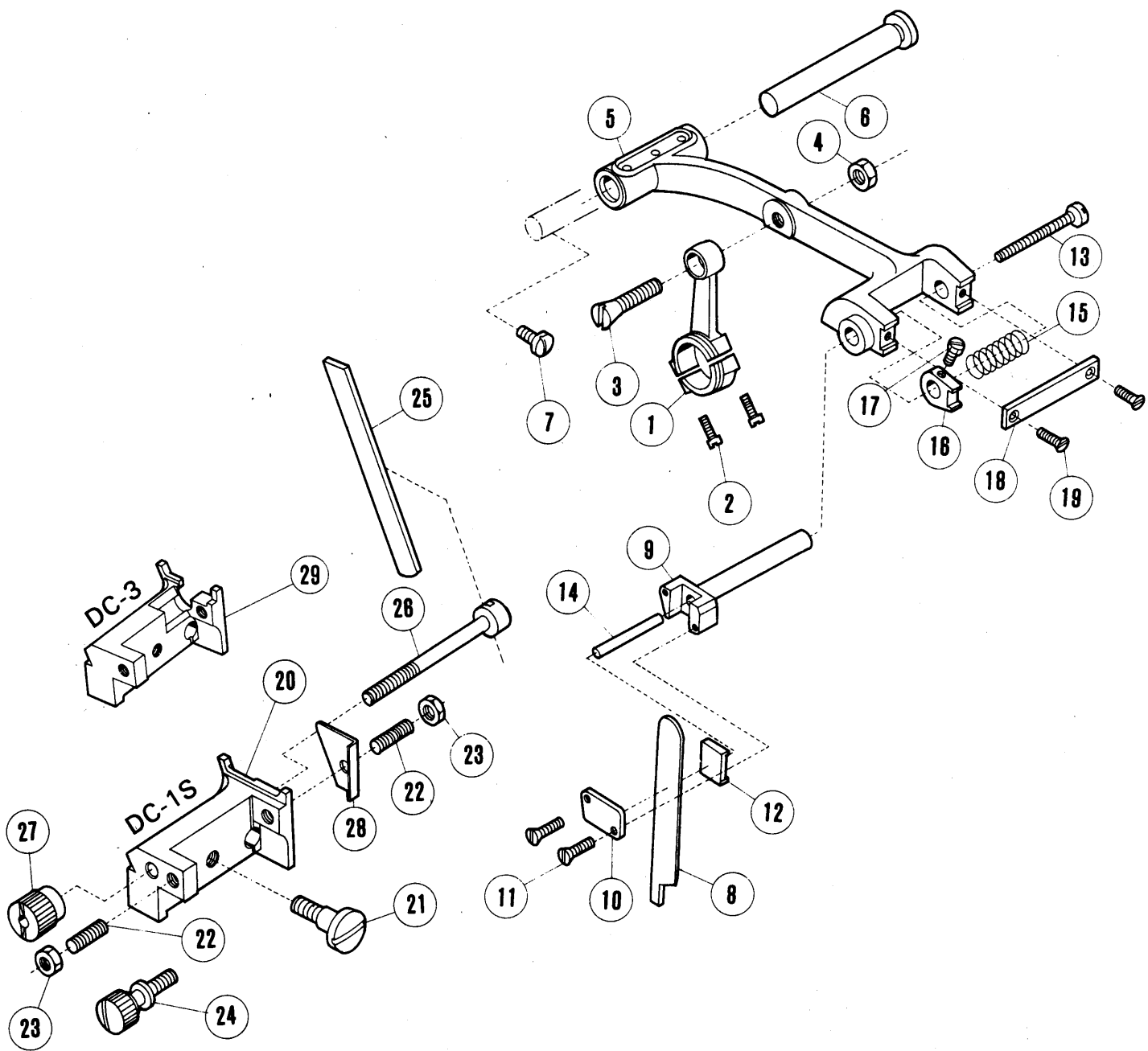

UPPER & LOWER KNIFE MECHANISM

上・下メス機構

Ref. No. 参照番号	Parts No. 部品番号	Name	名称	Qt. 数量
1	200102	Upper knife drive connection	上メスロッド(組)	1
2	1174	" " " " cap screw	〃 蓋止ネジ	2
3	2366-2	" " " " pivot screw	〃 テーパーネジ	1
4	3018	" " " " " " nut	〃 " ナット	1
5	137551A	" " lever	上メス台	1
6	137552	" " " " pin	〃 ピン	1
7	2133-1	" " " " screw	〃 〃 止ネジ	1
8	138559	" knife	上メス	1
9	138555A	" " carrier	上メス抱キ	1
10	198064	" " " " cap plate	〃 蓋	1
11	5224	" " " " " " screw	〃 〃 止ネジ	2
12	138556	" " gib	上メス押し	1
13	1132	" " " " screw	〃 ネジ	1
14	137560	" " " " pin	〃 ピン	1
15	137558	" " " " spring	〃 バネ	1
16	137554	" " guide	上メス案内	1
17	1222	" " " " screw	〃 止ネジ	1
18	137553	" " " " plate	上メス案内板	1
19	5259	" " " " " " screw	〃 止ネジ	2
20	137561	Lower knife carrier	下メス台	1
21	5065	" " " " screw	〃 止ネジ	1
22	1435	" " " " stop screw	〃 左右ストップネジ	2
23	3044	" " " " " " nut	〃 " ナット	2
24	5070	" " " " adjust screw	〃 調節ネジ	1
25	137562	" knife	下メス	1
26	137563	" " clamp	下メス止ピン	1
27	5069	" " " " nut	〃 ナット	1
28	137561-1	Needle plate support	下メス台カバー	1
29	138561	Lower knife carrier	下メス台	1

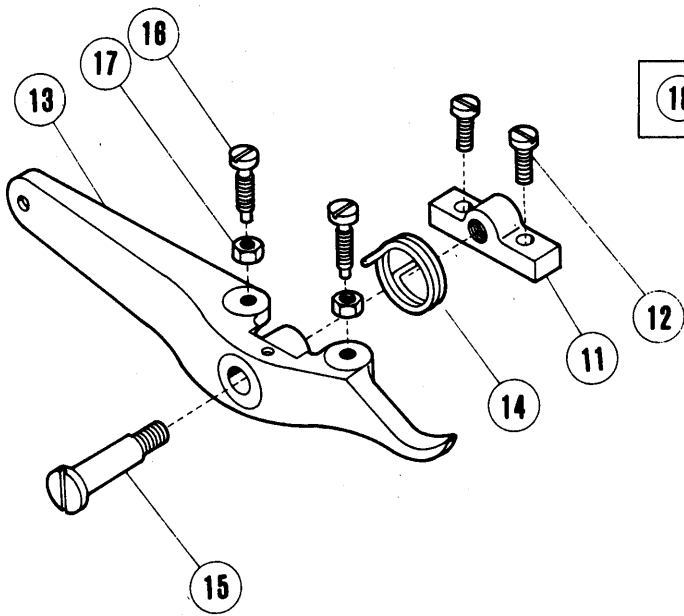
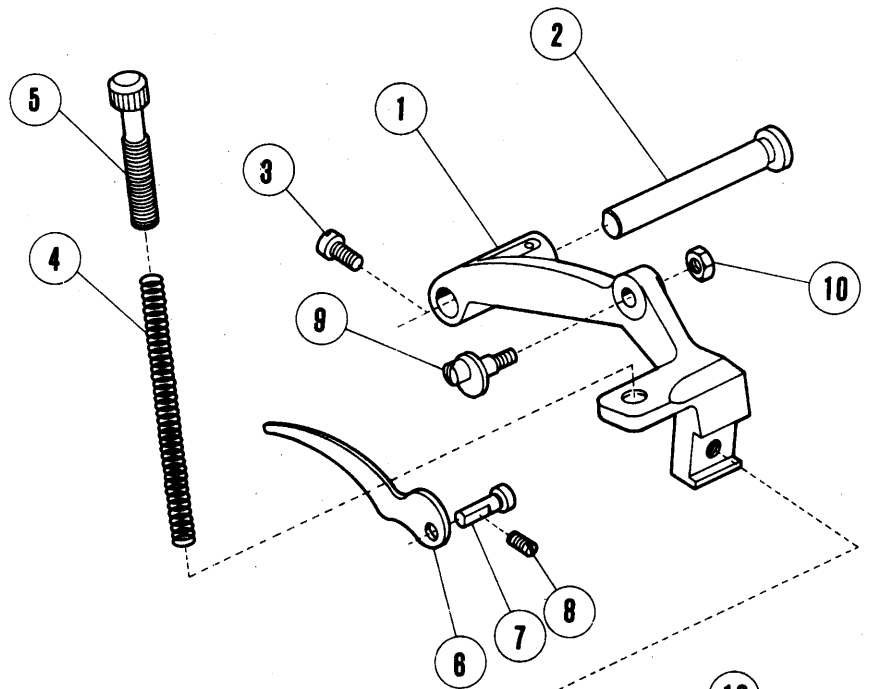

DC-1S

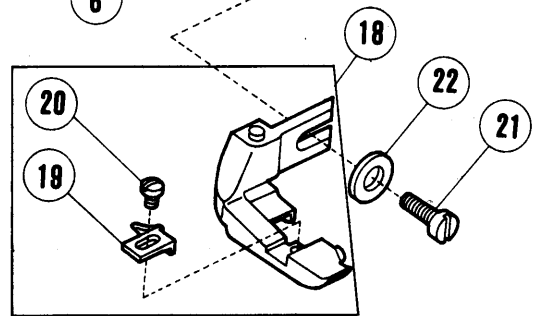

DC-3

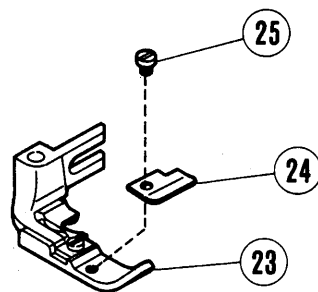
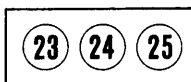

PRESSER FOOT & LIFTING MECHANISM

押 工 機 構

Ref. No. 参照番号	Parts No. 部品番号	Name	名 称	Qt. 数量
1	137140	Presser foot carrier	押エ台	1
2	137552	" " " pivot stud	〃 ピン	1
3	2213	" " " " " screw	〃 〃 止ネジ	1
4	137141	" " pressure spring	押エバネ	1
5	2371	" " " adjusting thumb screw	〃 〃 調節ネジ	1
6	137143	" " lifting hand lever	〃 手揚	1
7	5056	" " " " " pivot pin	〃 〃 ピン	1
8	1458	" " " " " " " screw	〃 〃 〃 止ネジ	1
9	2370	" " carrier hand lift stop screw	〃 〃 エキセンネジ	1
10	3044	" " " " " " " nut	〃 〃 〃 ナット	1
11	137145A	" " lifting lever bracket	〃 足揚台	1
12	2213	" " " " " " screw	〃 〃 止ネジ	2
13	137146	" " " lever	〃 足揚	1
14	137147	" " " " " spring	〃 〃 バネ	1
15	2285	" " " " " pivot stud	〃 〃 取付ネジ	1
16	2133	" " " " " stop screw	〃 〃 調節ネジ	2
17	3044	" " " " " " nut	〃 〃 〃 ナット	2
18	137160	" foot complete with 137161, 137162, 137164 137165, 1459, 137166, 137163, 1231	押エ(組) 137161, 137162, 137164, 137165, 1459, 137166, 137163, 1231/組	1
19	137163	" " chaining-off finger	〃 爪	1
20	1231	" " " " " screw	〃 〃 止ネジ	1
21	2308	" " screw	押エ止ネジ	1
22	137142	" " " washer	〃 〃 座金	1
23	139160	Presser foot, complete with 139162, 137163 & 1231	押エ(組) 139162, 137163, 1231/組	1
	139162	" " body	大押エ(組) 139161, 200114, 200796, 137162, 137166, 137164, 137165, 1459/組	1
	137163	" " chaining-off finger	押エ爪	
24	1231	" " " " " screw	〃 止ネジ	1
25	200271	" " material shield	押エ羽根	1
	5030	" " screw	〃 止ネジ	1

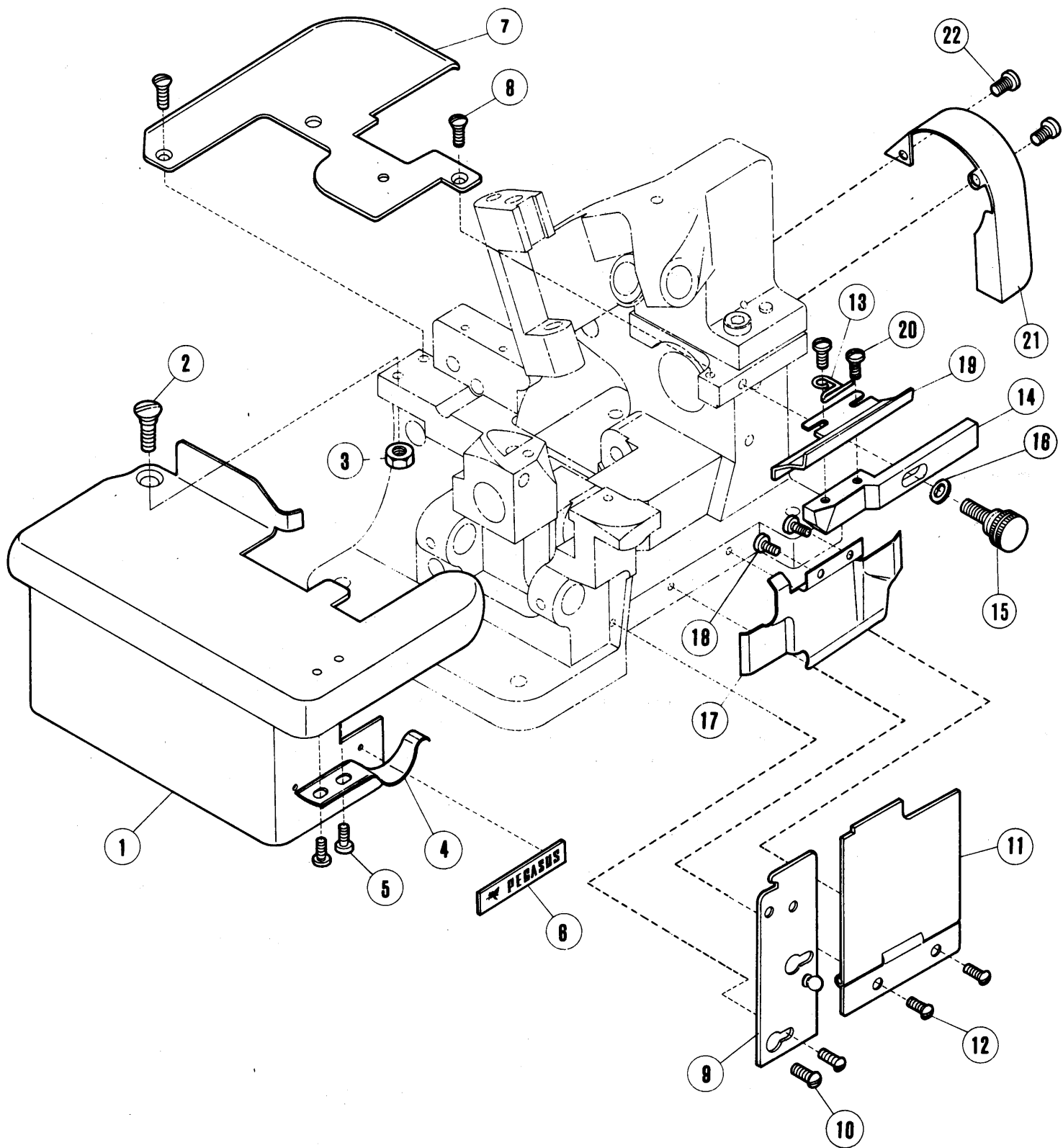

CLOTH PLATE & MISCELLANEOUS COVERS

カバ ー ・ 外 装 機 構

<u>Ref. No.</u> 参照番号	<u>Parts No.</u> 部品番号	<u>Name</u>	<u>名 称</u>	<u>Qt.</u> 数量
1	200637	Cloth plate	大カバー(組) 137007, 200638トノ組	1
2	2419	" " screw	ク 止ネジ	1
3	3144	" " " nut	ク ク ナット	1
4	137008	" " latch	ク 裏バネ	1
5	1234	" " " screw	ク ク 止ネジ	2
6	149010	" " name plate	ク 用銘板	1
7	137005	Feed drive linkage cover	後カバー	1
8	1732	" " " " screw	ク 止ネジ	2
9	137012	Looper cover	前カバー(組) 137013, 137012-1ノ組	1
10	1326	" " " screw	ク 止ネジ	2
11	137014A	Right looper thread cover	蝶番カバー	1
12	1326	" " " " screw	ク 止ネジ	2
13	137015	" " " " latch	ク バネ	1
14	137116	Upper knife guard bracket	角台	1
15	1281	" " " " screw	ク 止ネジ	1
16	137142	" " " " " washer	ク ク ワッシャー	1
17	137117A	Lint cover	ク カバー	1
18	1216	" " screw	ク ク 止ネジ	2
19	137118	Upper knife guard	切屑除ケ	1
20	1202	" " " screw	ク 止ネジ	2
21	149012	Pulley cover	プーリーカバー	1
22	1202	" " screw	ク 止ネジ	2

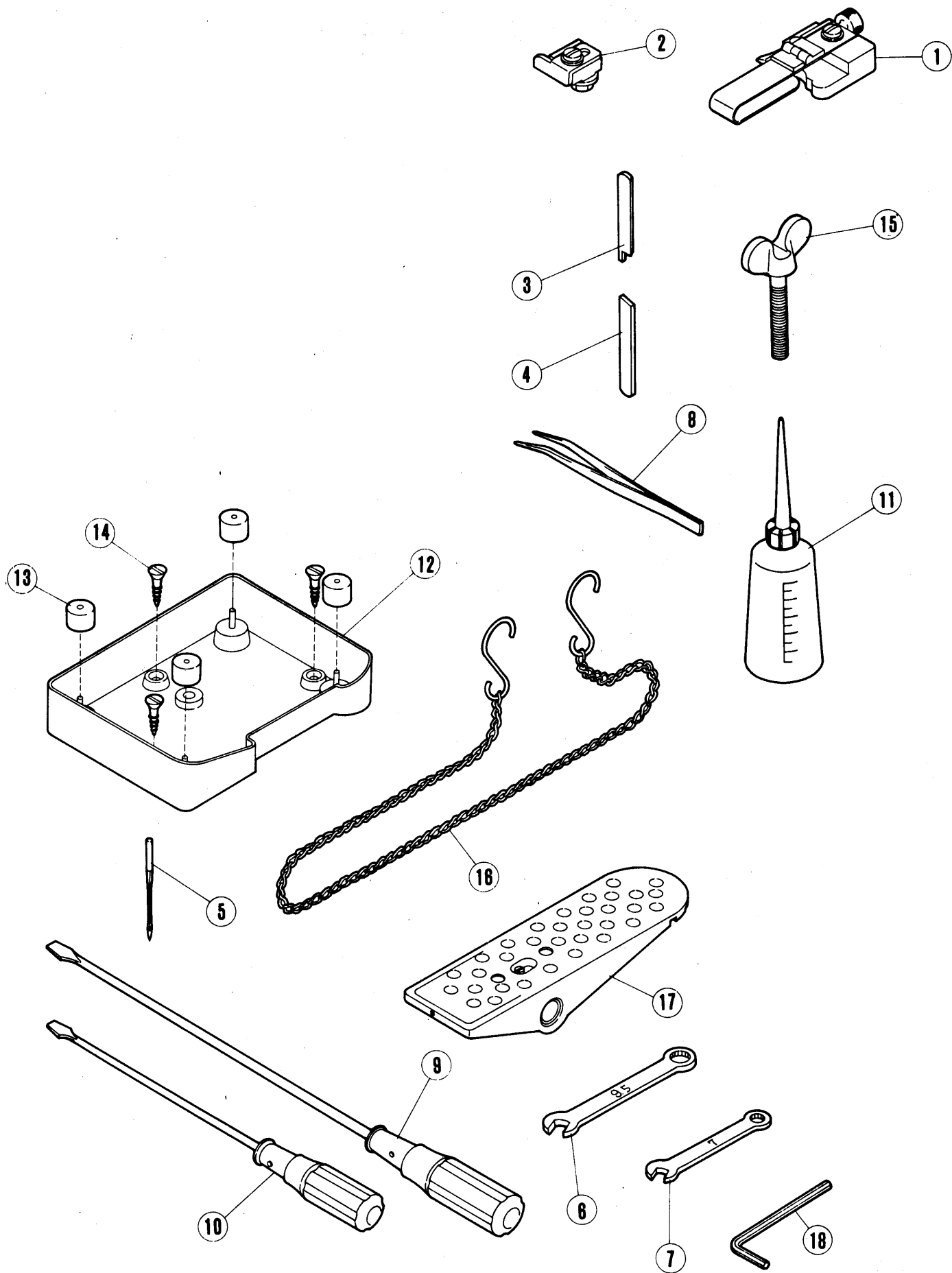

ACCESSORIES

付 属 品

Ref. No. 参照番号	Parts No. 部品番号	Name	名 称	Qt. 数量
1	200470	Welt guide	定規台(組) 137905, 2193, 137142, 2430, 137908, 1202, 137906トノ組	1
2	200471	Edge guide for model DC-3 only	〃 〃 138905, 2193, 137142, 200272, 1202, 137906トノ組	1
3	138559	Upper knife	上メス	1
4	137562	Lower knife	下メス	1
5	DC×1	Needle, size No. 9 (for domestics) or size No. 11 (for exports)	針 #9 (国内用) 針 #11 (貿易用)	10
6	286	Wrench (9.5 mm)	スパナ 9.5mm	1
7	284	〃 (7.0 mm)	〃 7 mm	1
8	131	Tweezers	ピンセット	1
9	127	Screw driver (large)	ネジ廻シ(大)	1
10	128	〃 〃 (medium)	〃 (中)	1
11	137	Oiler (containg 150cc oil)	油差シ (150cc油入り)	1
12	137004	Machine base	ベース	1
13	149014	〃 〃 cushion felt	ベース用フェルト	4
14	4908	〃 〃 screw	〃 止ネジ	2
15	137930	〃 mount screw	蝶ネジ	1
16	126	Treadle chain	鎖	1
17	121	Treadle	クツ(国内用)	1
	122	〃 (for exports)	〃 (貿易用)	1
18	182	Allen key/3.17 mm	キーレンチ/3.17mm	1

PART NO.	PAGE NO.	REF. NO.	PART NO.	PAGE NO.	REF. NO.	PART NO.	PAGE NO.	REF. NO.	PART NO.	PAGE NO.	REF. NO.
121	17	17	3044	7	29	137206A	3	18	200655	5	24
122	17		3044	11	23	137301	7	12	200674A	3	9
126	17	16	3044	13	10	137302	7	34	200821	5	47
127	17	9	3044	13	17	137307A	7	14	200821	7	47
128	17	10	3056	5	41	137308	7	36	200947	7	16
131	17	8	3056	7	19	137311	7	1	202010	5	12
137	17	11	3056	7	40	137402	9	9	202046	3	5
182	17	18	3119	5	36	137403	9	5	202088	9	38
284	17	7	3144	15	3	137404	9	8	202176	7	9
286	17	6	4908	17	14	137405	9	29	202176	7	32
1060	9	31	5002	9	2	137406	9	33	202177	5	22
1092	5	31	5010	5	4	137408	9	10	210319	5	44
1132	11	13	5010	7	4	137409	7	10	210319	7	22
1156	9	11	5030	13	25	137409	9	12	210319	7	43
1170-1	5	40	5051	3	23	137411	9	28			
1170-3	5	25	5052	3	22	137415	9	21			
1174	11	2	5053	7	35	137416	9	34			
1175-2	9	27	5053	9	25	137417	9	14			
1175-3	9	30	5056	13	7	137418A	9	1			
1186	5	29	5065	11	21	137420	9	18			
1196	5	19	5069	11	27	137421	9	20			
1196	7	13	5070	11	24	137440	9	15			
1196	7	37	5224	11	11	137441	9	19			
1202	9	36	5259	11	19	137442	9	22			
1202	15	20	5385	5	17	137455	9	26			
1202	15	22	101113	5	42	137456	9	35			
1216	5	27	101113	7	20	137551A	11	5			
1216	7	18	101113	7	41	137552	11	6			
1216	15	18	137002	3	1	137552	13	2			
1222	5	23	137003A	3	2	137553	11	18			
1222	11	17	137004	17	12	137554	11	16			
1231	13		137005	15	7	137558	11	15			
1231	13	20	137008	15	4	137560	11	14			
1234	15	5	137011W	3	6	137561	11	20			
1281	15	15	137011W	3	8	137561-1	11	28			
1326	15	10	137012	15	9	137562	11	25			
1326	15	12	137014A	15	11	137562	17	4			
1435	11	22	137015	15	13	137563	11	26			
1457	5	13	137016	7	46	137564	5	39			
1457-1	7	39	137101	5	26	137930	17	15			
1458	13	8	137102	5	18	137950	3	4			
1732	5	38	137103	7	38	138555	11	9			
1732	15	8	137104	7	17	138556	11	12			
1817-2A	5	45	137105	5	46	138559	11	8			
1817-2A	7	23	137106	7	25	138559	17	3			
1817-2A	7	44	137107	5	28	138561	11	29			
1936A	3	3	137108	5	30	139019W	3	24			
2022	3	12	137109	5	32	139135	5	48			
2022	5	6	137113	5	43	139160	13	23			
2022	5	9	137114	7	42	139162	13				
2022-3	3	16	137115	7	21	139301	7	48			
2022-3	3	19	137116	15	14	140402	9	37			
2022-3	7	33	137117A	15	17	149010	15	6			
2022-3	9	6	137118	15	19	149014	17	13			
2022-3	9	13	137120	5	1	149022	9	39			
2022-4	7	6	137121	5	5	149023	3	7			
2022-4	7	11	137121	7	5	198053	9	24			
2133	13	16	137122	5		198064	11	10			
2133-1	11	7	137123A	5	34	200037	5	11			
2213	13	3	137127	5	7	200102	11	1			
2213	13	12	137128	5	10	200271	13	24			
2213-1	5	2	137130	5	3	200334	3	17			
2213-1	7	2	137130	7	3	200335	3	20			
2237	9	23	137135A	5	37	200389	3	14			
2285	13	15	137140	13	1	200389	5	14			
2308	13	21	137141	13	4	200470	17	1			
2366	9	3	137142	7	24	200471	17	2			
2366	9	16	137142	7	45	200607	3	13			
2366-2	11	3	137142	13	22	200607	5	15			
2368	3	11	137142	15	16	200619	7	7			
2370	13	9	137143	13	6	200620	7	8			
2371	13	5	137145A	13	11	200621A	7	26			
2419	15	2	137146	13	13	200622A	7	27			
2425	9	32	137147	13	14	200623A	7	28			
2913-1	5	8	137160	13	18	200624	7	30			
2922	7	15	137163	13		200625	7	31			
2922	9	7	137163	13	19	200637	15	1			
3018	9	4	137202	3	10	200652	5	16			
3018	9	17	137204	3	21	200653	5	20			
3018	11	4	137205	3	15	200654	5	21			

■ PEGASUS
SEWING MACHINE MFG.
CO., LTD.®

