

BAS-342G

パーツブック
PARTS BOOK

ダイレクトドライブ

プログラム式電子ミシン

DIRECT DRIVE

PROGRAMMABLE ELECTRONIC PATTERN SEWER

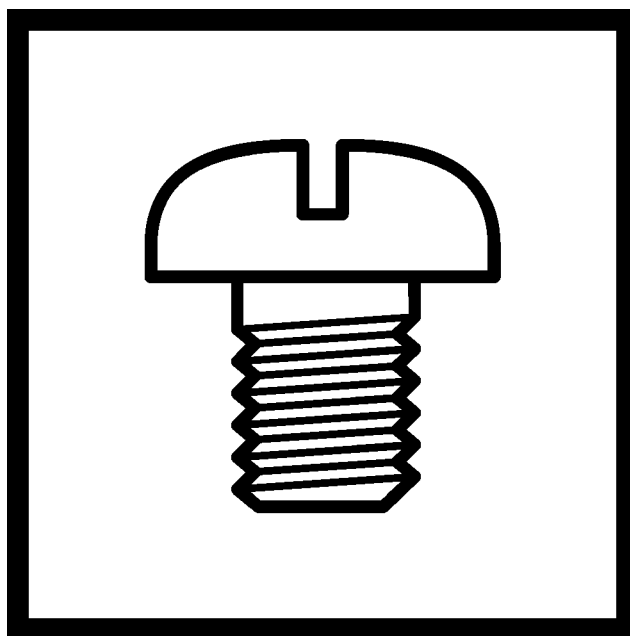

brother[®]

最新の部品情報は Parts Navigation でご覧いただけます。
The latest parts information, refer to the Parts Navigation.

<http://partsbook.brother.co.jp/partsnavi/jpn/>
<http://partsbook.brother.co.jp/partsnavi/eng/>

型式板の見方



1: 厚物

Description of model plate

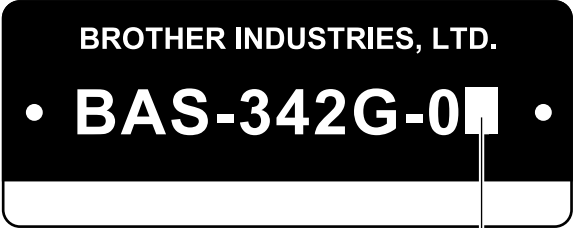

1: Heavy-weight materials

パーツブックご利用に際して

1. この本は、2007年5月のデータに基づいて作成されたものです。
2. 部品は予告なしに設計変更される場合があります。
3. 組単位で補給する部品は、破線で示してあります。

目 次

A1. 主体関係	1
A2. 主体関係	5
B. 上軸・針棒関係	7
C1. 送り関係	9
C2. 送り関係	11
C3. 送り関係	13
D1. 押え上げ関係	15
D2. 押え上げ関係	17
E. 下軸関係	19
F. 給油潤滑関係	21
G. 糸通し関係	25
H. 糸巻関係	27
J. 糸切り関係	29
K. 糸払い関係	33
L. 糸緩め関係	35
M1. コントロールボックス関係	37
M2. コントロールボックス関係(電源モータ基板)	39
N. スイッチ関係	41
P. 空圧関係	43
Q. 電装品関係	45
R. 操作パネル関係	47
S. モータ関係	49
T. 踏板関係	51
U. 動力台関係	53
V. プログラマー関係	55
W1. 付属装置関係(オプション部品)	57
W2. 付属装置関係(オプション部品)	59
W3. 付属装置関係(オプション部品)	61
W4. 付属装置関係(オプション部品)	63
W5. 付属装置関係(オプション部品)	65
Z. 付属品関係	67
Wa. 警告ラベル	69
Ap. 用途別部品一覧表	70
Ga. ゲージ部品一覧表	72
索引	73

Notes for using this parts book

1. This book was prepared based on information available in May 2007.
2. Parts are subject to changes in design without prior notice.
3. Parts supplied as complete assemblies are circled by a dotted line.

CONTENTS

A1. Machine body	1
A2. Machine body	5
B. Upper shaft and needle bar mechanism	7
C1. Feed mechanism	9
C2. Feed mechanism	11
C3. Feed mechanism	13
D1. Work clamp lifter mechanism	15
D2. Work clamp lifter mechanism	17
E. Lower shaft mechanism	19
F. Lubrication	21
G. Threading mechanism	25
H. Bobbin winder mechanism	27
J. Thread trimmer mechanism	29
K. Thread wiper mechanism	33
L. Tension release mechanism	35
M1. Control box mechanism	37
M2. Control box mechanism (Power supply motor PCB)	39
N. Power switch mechanism	41
P. Air pressure mechanism	43
Q. Power supply equipment mechanism	45
R. Operation panel mechanism	47
S. Motor mechanism	49
T. Foot switch pedal mechanism	51
U. Power table	53
V. Programmer	55
W1. Attachment set (Option parts)	57
W2. Attachment set (Option parts)	59
W3. Attachment set (Option parts)	61
W4. Attachment set (Option parts)	63
W5. Attachment set (Option parts)	65
Z. Accessories	67
Wa. Warning labels	69
Ap. Parts list sorted by application	70
Ga. Gauge parts list	72
Index	73

A1 . 主体関係 / Machine body

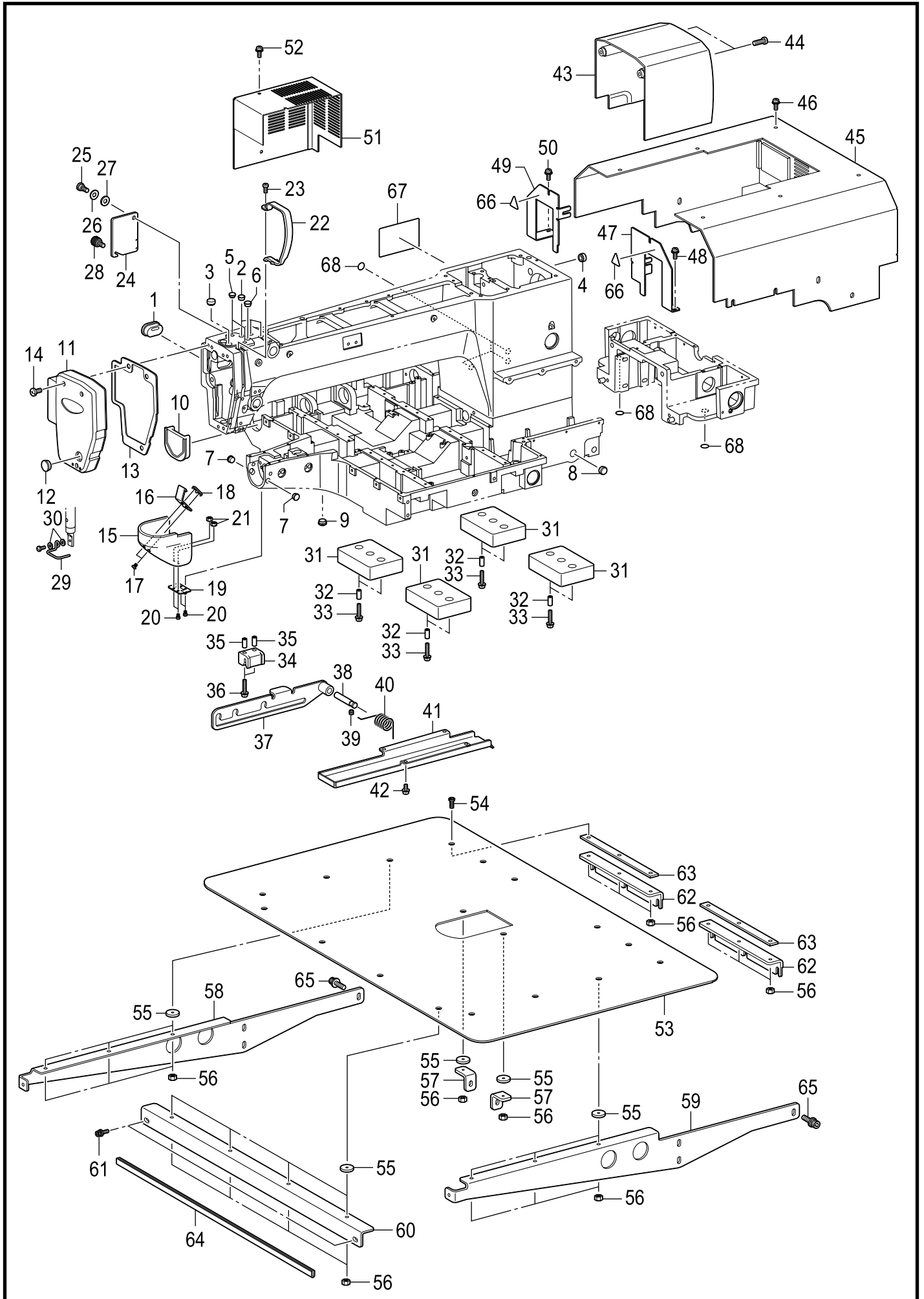

A1. 主体関係 / Machine body

REF.NO	CODE	Q'TY	品名	NAME OF PARTS	RM
1	SA4596001	1	ゴムセン20-15	RUBBER CAP 20-15	
2	104821001	3	ゴムセン10.5	RUBBER CAP, 10.5	
3	S20164001	1	ゴムセン13	RUBBER CAP, 13	
4	S20164001	1	ゴムセン13	RUBBER CAP, 13	
5	104450101	2	ゴムセン8	RUBBER CAP, 8	
6	117936001	1	ゴムセン9.4	RUBBER CAP, 9.4	
7	S44010001	2	ゴムセン11.5	RUBBER CAP, 11.5	
8	150592001	1	ゴムセン16	RUBBER CAP, 16	
9	104449001	1	ゴムセン15.5	RUBBER CAP, 15.5	
10	SA8548101	1	ベッドカバー-ゴム	BED COVER	
11	SA4600001	1	メンイタ	FACE PLATE	
12	104449001	1	ゴムセン15.5	RUBBER CAP, 15.5	
13	SA4601001	1	メンイタパッキン	F-PLATE PACKING	
14	062061016	3	ナベコ6X10	SCREW PAN M6X10	
15	SA4603101	1	オオカマカバー	SHUTTLE RACE COVER	
16	SA6272001	1	オオカマカバー-フツクD	SHUTTLE RACE COVER HOOK D	
17	004300513	2	+サラコ3X5	SCREW, FLAT M3X5	
18	SA3264001	1	イタナツト	NUT PLATE	
19	SA6207001	1	チヨウバン	HINGE	
20	062300506	4	ナベコ3X5	SCREW PAN M3X5	
21	021300103	2	1シュナツト3	NUT, 1 M3	
22	SA3200101	1	テンビンカバー	THREAD TAKE-UP COVER	
23	062401006	1	ナベコ4X10	SCREW PAN M4X10	
24	SA4604001	1	カンケツカバー	STEPPING COVER	
25	SA3306001	1	ダンネジ7-3	SHOULDER SCREW, 7-3	
26	120265002	1	ナミバネザガネ	SPRING WASHER	
27	S07350002	1	ザガネ	WASHER PLAIN	
28	S36475000	1	ツマミネジM5	SCREW, M5	
29	SA8679001	1	フィンガーガード	FINGER GUARD	
30	025350332	2	ヒラザガネダイ3.5	WASHER PLAIN L 3.5	
31	SA8670001	4	クッション	CUSHION	
32	SA8680001	8	カラ-	SPACER	
33	0A5402005	8	+ナベザクミ4X20DB	SCREW PAN (S/P WASHER) M4X20	
34	SA8880001	1	ボウシンゴム	RUBBER CUSHION	
35	SA8680001	2	カラ-	SPACER	
36	0A5402005	2	+ナベザクミ4X20DB	SCREW PAN (S/P WASHER) M4X20	
37	SA8549001	1	トウブササエレバー	SUPPORT LEVER	
38	SA8550001	1	トウブササエレバー-ジク	SUPPORT LEVER SHAFT	
39	012060636	1	アナヒラ6X6	SET SCREW SOCKET (FT) M6X6	
40	SA8551001	1	トウブササエレバー-バネ	TOSHON SPRING	
41	SA8552001	1	カマハイユウケ	OIL PAN	
42	0A5401006	4	+ナベザクミ4X10DB	SCREW PAN (S/P WASHER) M4X10	
43	SA8553001	1	モーターカバー	MOTOR COVER	
44	062061616	2	ナベコ6X16	SCREW PAN M6X16	
45	SA8816001	1	リヤカバー-クミ	REAR COVER ASSY	
46	0A5401006	16	+ナベザクミ4X10DB	SCREW PAN (S/P WASHER) M4X10	
47	SA8555001	1	リヤカバー-FR	REAR COVER	
48	0A5401006	3	+ナベザクミ4X10DB	SCREW PAN (S/P WASHER) M4X10	
49	SA8556001	1	リヤカバー-FL	REAR COVER	
50	0A5401006	3	+ナベザクミ4X10DB	SCREW PAN (S/P WASHER) M4X10	
51	SA8557001	1	Xモーターカバー	X MOTOR COVER	
52	0A5401006	4	+ナベザクミ4X10DB	SCREW PAN (S/P WASHER) M4X10	
53	SA8559001	1	ハリイタホジョイタ	AUXILIARY PLATE	
54	SA8560001	18	シメネジ4X12	SCREW M4X12	
55	SA4677101	12	ホジョイタクッション	AUXILIARY PLATE CUSHION	
56	021400206	18	2シュナツト4	NUT 2 M4	
57	SA4676101	2	ホジョイタブラケット	AUXILIARY PLATE BRACKET	
58	SA8561001	1	ホジョイタブラケットL	AUXILIARY PLATE BRACKET L	
59	SA8562001	1	ホジョイタブラケットR	AUXILIARY PLATE BRACKET R	
60	SA8563001	1	ホジョイタブラケットM	AUXILIARY PLATE BRACKET M	
61	S55481001	2	アナボルトザクミ4X12	BOLT SOCKET (S/P WASHER) M4X12	
62	SA8564001	2	ホジョイタブラケットB	AUXILIARY PLATE BRACKET B	
63	SA8672001	2	ホジョイタクッションB	AUXILIARY PLATE CUSHION B	

A1 . 主体関係 / Machine body

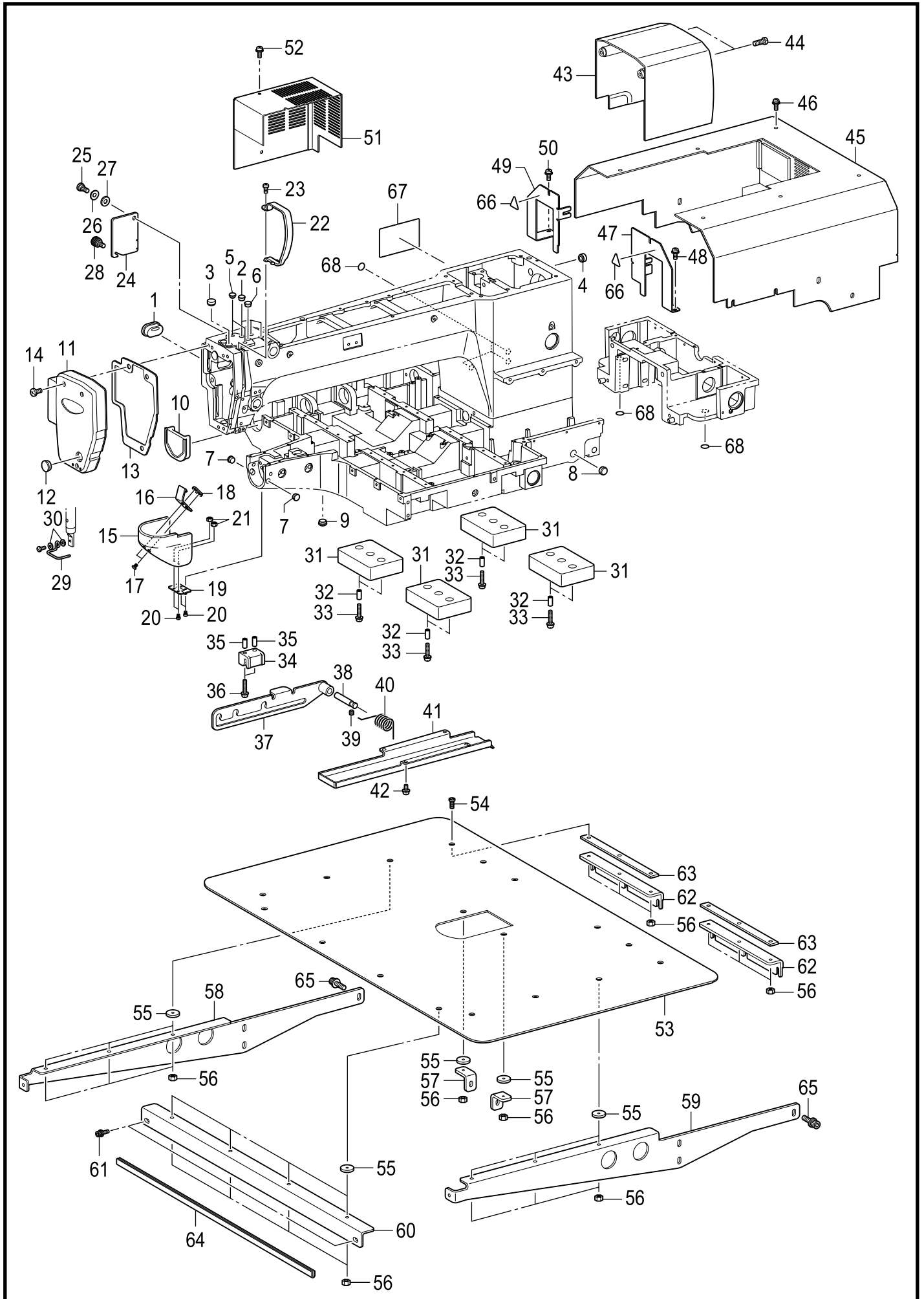

BAS-342G-050

A1. 主体関係 / Machine body

REF.NO	CODE	Q'TY	品名	NAME OF PARTS	RM
64	SA8879001	1	トリムL540	TRIMS L540	
65	S42446001	14	アナボルトザクミ6X14	BOLT SOCKET (S/P WASHER) M6X14	
66	S36924002	2	ワーニングマーク	INJURY MARK	
			<日本向>	<For Japan only>	
67	SA0792001	1	ラベルチュウイ.ワイ	LABEL CAUTION JPN/ENG	
			<日本向以外>	<Except for Japan>	
67	SA0793001	1	ラベルチュウイ.チュウエイ	LABEL CAUTION CHN/ENG	
			<欧州向用以外>	<Except for Europe>	
68	S37060001	3	アスマーク	LABEL, GROUNDING	
			<欧州向用>	<For Europe only>	
68	S37060001	5	アスマーク	LABEL, GROUNDING	

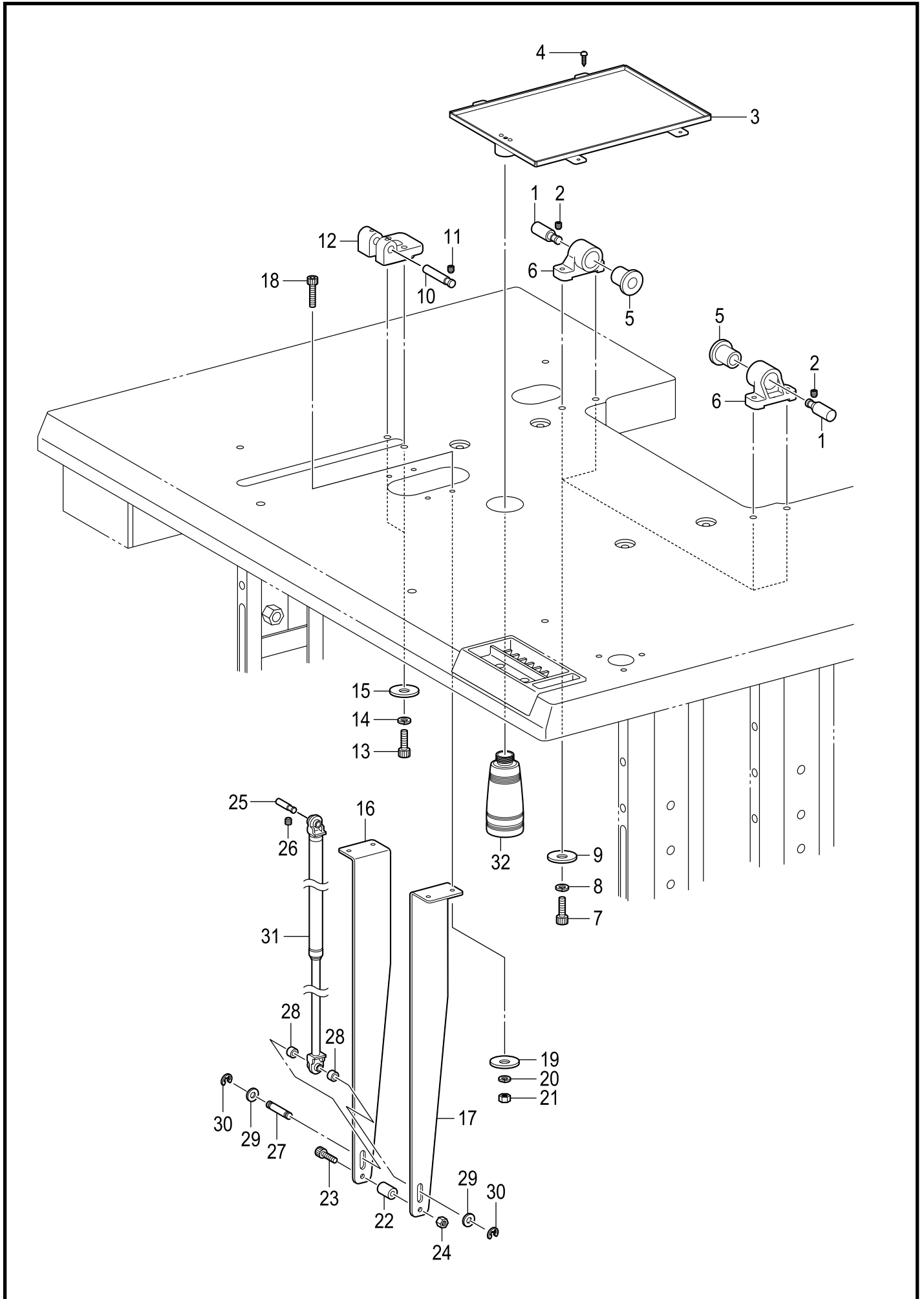

A2. 主体関係 / Machine body

REF.NO	CODE	Q'TY	品名	NAME OF PARTS	RM
1	SA8668001	2	トウブヒンジジク	HINGE SHAFT	
2	012060636	2	アナヒラ6X6	SET SCREW SOCKET (FT) M6X6	
3	SA8665001	1	アブラウケクミ	OIL PAN ASSY	
4	032361306	4	+2マルモク35X13	WOOD SCREW ROUND 2 M3.5X13	
5	SA8667001	2	ゴムブッシュ	RUBBER BUSH	
6	SA8669001	2	ヒンジジクササエ	HINGE HOLDER	
7	018087036	4	アナボルト8X70	BOLT SOCKET M8X70	
8	028080246	4	バネザガネ2-8	WASHER SPRING 2-8	
9	213650001	4	ワ2.3X8.5X38ST	WASHER 2.3X8.5X38ST	
10	SA8550001	1	トウブササエレバ-ジク	SUPPORT LEVER SHAFT	
11	012060636	2	アナヒラ6X6	SET SCREW SOCKET (FT) M6X6	
12	SA8671001	1	トウブササエダイ	SUPPORT LEVER BASE	
13	018087036	2	アナボルト8X70	BOLT SOCKET M8X70	
14	028080246	2	バネザガネ2-8	WASHER SPRING 2-8	
15	213650001	2	ワ2.3X8.5X38ST	WASHER 2.3X8.5X38ST	
16	SA8673001	1	ガススプリングササエL	HOLDER ABSORBER L	
17	SA8674001	1	ガススプリングササエR	HOLDER ABSORBER R	
18	SA3387001	4	アナボルト6X75	BOLT, SOCKET M6X75	
19	213650001	4	ワ2.3X8.5X38ST	WASHER 2.3X8.5X38ST	
20	028060246	4	バネザガネ2-6	WASHER SPRING 2-6	
21	021060106	4	1シュナット6	NUT 1 M6	
22	SA5251001	1	スペ-サ	SPACER	
23	018064031	1	アナボルト6X40	BOLT SOCKET M6X40	
24	021060106	1	1シュナット6	NUT 1 M6	
25	SA4847001	1	ガススプリングジクU	SHAFT U	
26	012060636	1	アナヒラ6X6	SET SCREW SOCKET (FT) M6X6	
27	S17974101	1	ガススプリングジクD	SHAFT D	
28	S17975100	2	GSジクカラ-	SHAFT COLLAR, GAS	
29	025080132	2	ヒラザガネシヨウ8	WASHER PLAIN S 8	
30	048060342	2	トメワE6	RETAINING RING E6	
31	SA8675001	1	ガススプリング	SHOCK ABSORBER GAS	
32	114486002	1	ポリオイラ-タイ	OILER	

B. 上軸・針棒関係 / Upper shaft and needle bar mechanism

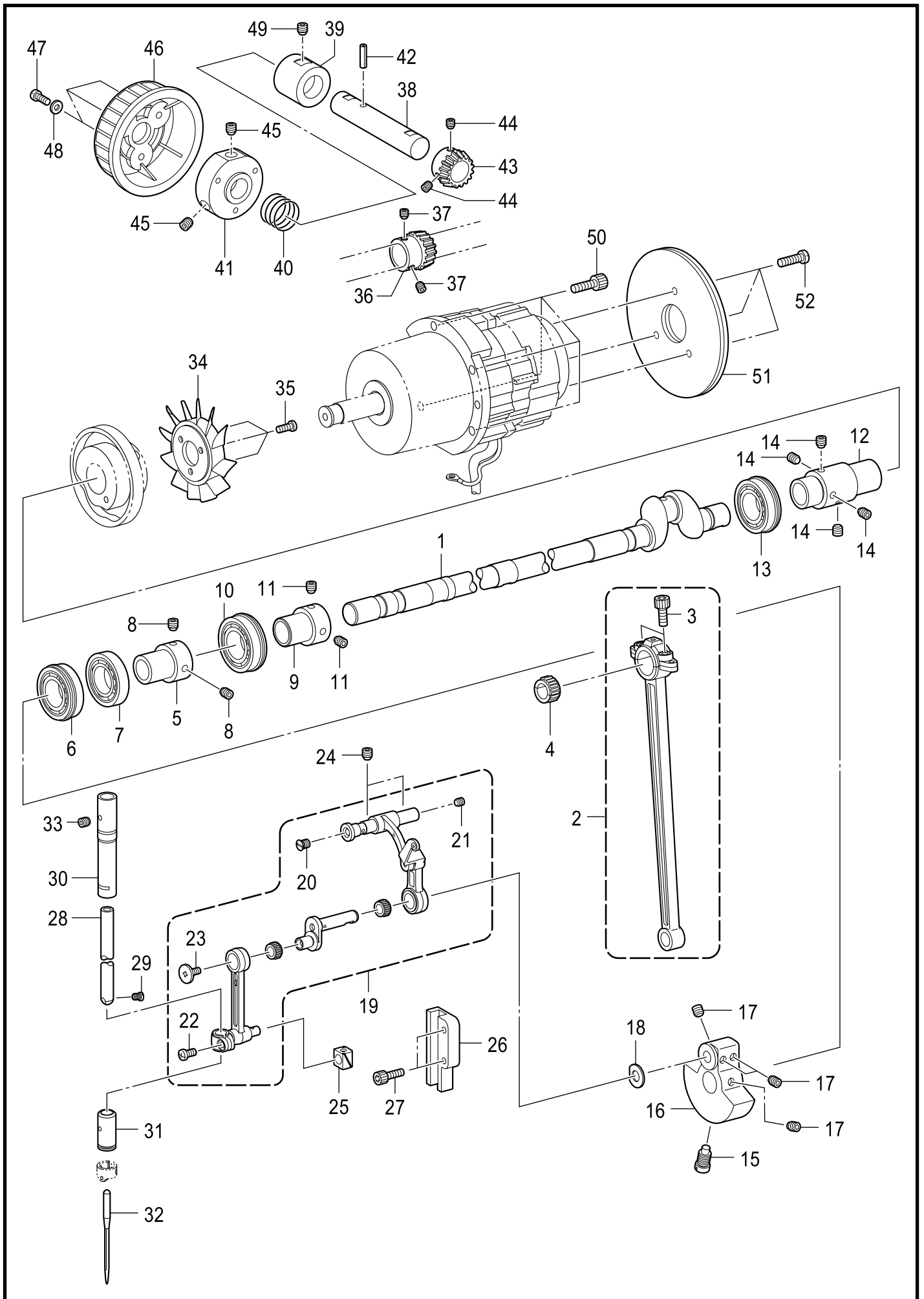

B. 上軸 ・ 針棒関係 / Upper shaft and needle bar mechanism

REF.NO	CODE	Q'TY	品名	NAME OF PARTS	RM
1	SA8565101	1	ウワジク	UPPER SHAFT	
2	SA3499001	1	クランクロッドクミ	CRANK ROD ASSY	
3	018501636	2	アナボルト5X16	BOLT SOCKET M5X16	
4	SA4172001	1	ニードルベアリング:青色	NEEDLE BEARING: BLUE	
4	SA4173001	1	ニードルベアリング:黒色	NEEDLE BEARING: BLACK	
4	SA4174001	1	ニードルベアリング:灰色	NEEDLE BEARING: GRAY	
4	SA4175001	1	ニードルベアリング:黄色	NEEDLE BEARING: YELLOW	
5	SA3206001	1	ベアリングブッシュ	BALL BEARING BUSH	
6	SA4179001	1	タマジクウケ6904DDUNR	BALL BEARING 6904DDUNR	
7	SA4180001	1	タマジクウケ6904DDU	BALL BEARING 6904DDU	
8	S23651001	2	アナヒラ6X6ホソメ	SET SCREW SOCKET (FT) M6X6	
9	SA3206001	1	ベアリングブッシュ	BALL BEARING BUSH	
10	SA4177001	1	タマジクウケ6004DDUNR	BALL BEARING 6004DDUNR	
11	S23651001	2	アナヒラ6X6ホソメ	SET SCREW SOCKET (FT) M6X6	
12	SA4608101	1	ツギテG	JOINT G	
13	SA4178001	1	タマジクウケ6204DDUNR	BALL BEARING 6204DDUNR	
14	S23651001	4	アナヒラ6X6ホソメ	SET SCREW SOCKET (FT) M6X6	
15	S25235001	1	シメネジ8	SCREW M8	
16	SA4609101	1	ツリアイクランクG	THREAD TAKE-UP CRANK G	
17	S23651001	4	アナヒラ6X6ホソメ	SET SCREW SOCKET (FT) M6X6	
18	110367001	1	ザガネ	WASHER, PLAIN SPECIAL 8	
19	SA6182001	1	ハリボウレンカンFKクミ	THREAD TAKE-UP LEVER FK SET	
20	SA2958001	1	サラネジ5X6	SCREW FLAT M5X6	
21	012500536	1	アナヒラ5X5	SET SCREW SOCKET (FT) M5X5	
22	062400816	1	ナベコ4X8	SCREW PAN M4X8	
23	145465001	1	シメネジ3.57L	SCREW, SM3.57-40X6 L	
24	012060636	2	アナヒラ6X6	SET SCREW SOCKET (FT) M6X6	
25	142211001	1	カクコマ	SLIDE BLOCK	
26	SA3528001	1	カクコマアンナイB	SLIDE BLOCK GUIDE	
27	018401636	2	アナボルト4X16	BOLT SOCKET M4X16	
28	SA4622001	1	ハリボウ	NEEDLE BAR	
29	144458001	1	アタマツキトメネジ3.57	SET SCREW, SM3.57-40X4.5	
30	SA4666001	1	ハリボウメタルUK	NEEDLE BAR BUSH UK	
31	SA3224001	1	ハリボウメタルD	NEEDLE BAR BUSH D	
32	145646019	1	ミシンハリDPX17	NEEDLE, DPX17	
33	012060536	1	アナヒラ6X5	SET SCREW, SOCKET (FT) M6X5	
34	S38713100	1	ファン	FAN	
35	062400816	3	ナベコ4X8	SCREW PAN M4X8	
36	SA6108001	1	プーリギアR	PULLEY GEAR R	
37	012500536	2	アナヒラ5X5	SET SCREW SOCKET (FT) M5X5	
38	SA4626101	1	プーリジク	PULLEY SHUFT	
39	SA4627001	1	プーリメタル	PULLEY BUSH	
40	SA4628101	1	プーリバネ	PULLEY SPRING	
41	SA4629001	1	プーリダイ	PULLEY BASE	
42	047401242	1	スプリングピンAW4	PIN SPRING ROLL AW4	
43	SA4624001	1	プーリギアル	PULLEY GEAR L	
44	012500536	2	アナヒラ5X5	SET SCREW SOCKET (FT) M5X5	
45	S23651001	2	アナヒラ6X6ホソメ	SET SCREW SOCKET (FT) M6X6	
46	SA4630001	1	プーリ	PULLEY	
47	062401006	3	ナベコ4X10	SCREW PAN M4X10	
48	SA5158101	3	ヒラザガネダイ4アツ	WASHER PLAIN L 4	
49	012060636	1	アナヒラ6X6	SET SCREW SOCKET (FT) M6X6	
50	018501636	4	アナボルト5X16	BOLT SOCKET M5X16	
51	SA5230001	2	フライホイール2	FRIES WHEEL 2	
52	062401016	3	ナベコ4X10	SCREW PAN M4X10	

C1. 送り関係 / Feed mechanism

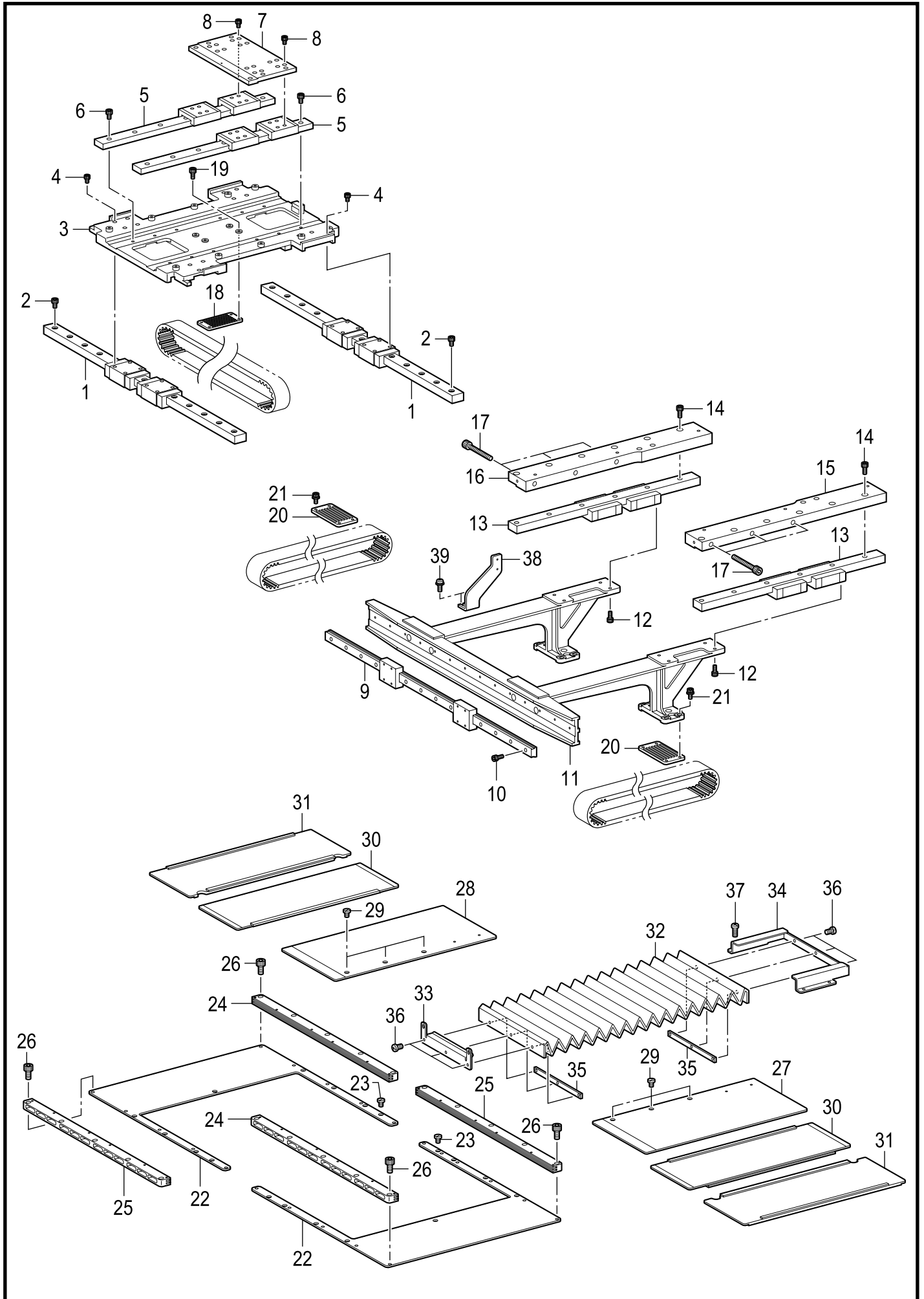

BAS-342G-202

C1. 送り関係 / Feed mechanism

REF.NO	CODE	Q'TY	品名	NAME OF PARTS	RM
1	SA8566001	2	X-LMガイドF	X-LM GUIDE F	
2	018400836	22	アナボルト4X8	BOLT SOCKET M4X8	
3	SA8567001	1	Xベ-スイタ	BASE PLATE X	
4	018300536	16	アナボルト3X5	BOLT SOCKET M3X5	
5	SA8568001	2	Y-LMガイドF	Y-LM GUIDE F	
6	018400836	12	アナボルト4X8	BOLT SOCKET M4X8	
7	SA8569101	1	Yベ-スイタクミ	BASE PLATE Y ASSY	
8	018300536	16	アナボルト3X5	BOLT SOCKET M3X5	
9	SA8571001	1	X-LMガイドR	X-LM GUIDE R	
10	018301036	14	アナボルト3X10	BOLT SOCKET M3X10	
11	SA8819001	1	Yア-ムクミ	Y-ARM ASSY	
12	018401236	8	アナボルト4X12	BOLT SOCKET M4X12	
13	SA8574001	2	Y-LMガイドR	Y-LM GUIDE R	
14	018501236	12	アナボルト5X12	BOLT SOCKET M5X12	
15	SA8575001	1	YリニアガイドササエR	Y-LM GUIDE BRACKET R	
16	SA8576001	1	YリニアガイドササエL	Y-LM GUIDE BRACKET L	
17	018066036	6	アナボルト6X60	BOLT SOCKET M6X60	
18	SA8590001	1	ベルトオサエイタ	BELT HOLDER	
19	018401036	4	アナボルト4X10	BOLT SOCKET M4X10	
20	SA8590001	2	ベルトオサエイタ	BELT HOLDER	
21	S55481001	8	アナボルトザクミ4X12	BOLT SOCKET (S/P WASHER) M4X12	
22	SA8608001	2	コテイカバー	FIXATION	
23	SA3538001	14	シメネジ4X8	SCREW, M4X8	
24	SA8609001	2	カバーレールFRクミ	COVER RAIL FR ASSY	
25	SA8611001	2	カバーレールFLクミ	COVER RAIL FL ASSY	
26	018401036	20	アナボルト4X10	BOLT SOCKET M4X10	
27	SA8612001	1	ウチカバー-Rクミ	INSIDE COVER R ASSY	
28	SA8615001	1	ウチカバー-Lクミ	INSIDE COVER L ASSY	
29	SA3538001	6	シメネジ4X8	SCREW, M4X8	
30	SA8617001	2	ナカカバークミ	MIDDLE COVER ASSY	
31	SA8619001	2	ソトカバークミ	OUTSIDE COVER ASSY	
32	SA8622001	1	ジャバラ	BELLOW	
33	SA8623001	1	ジャバラオサエF	BELLOW PRESSER F	
34	SA8624001	1	ジャバラオサエR	BELLOW PRESSER R	
35	SA8625001	2	ジャバラナット	BELLOW NUT	
36	062300416	6	ナベコ3X4	SCREW PAN M3X4	
37	062401016	4	ナベコ4X10	SCREW PAN M4X10	
38	SA8626001	1	Yセンサートリツケイタ	SENSOR PLATE Y	
39	0A5401006	2	+ナベザクミ4X10DB	SCREW PAN (S/P WASHER) M4X10	

C2 . 送り関係 / Feed mechanism

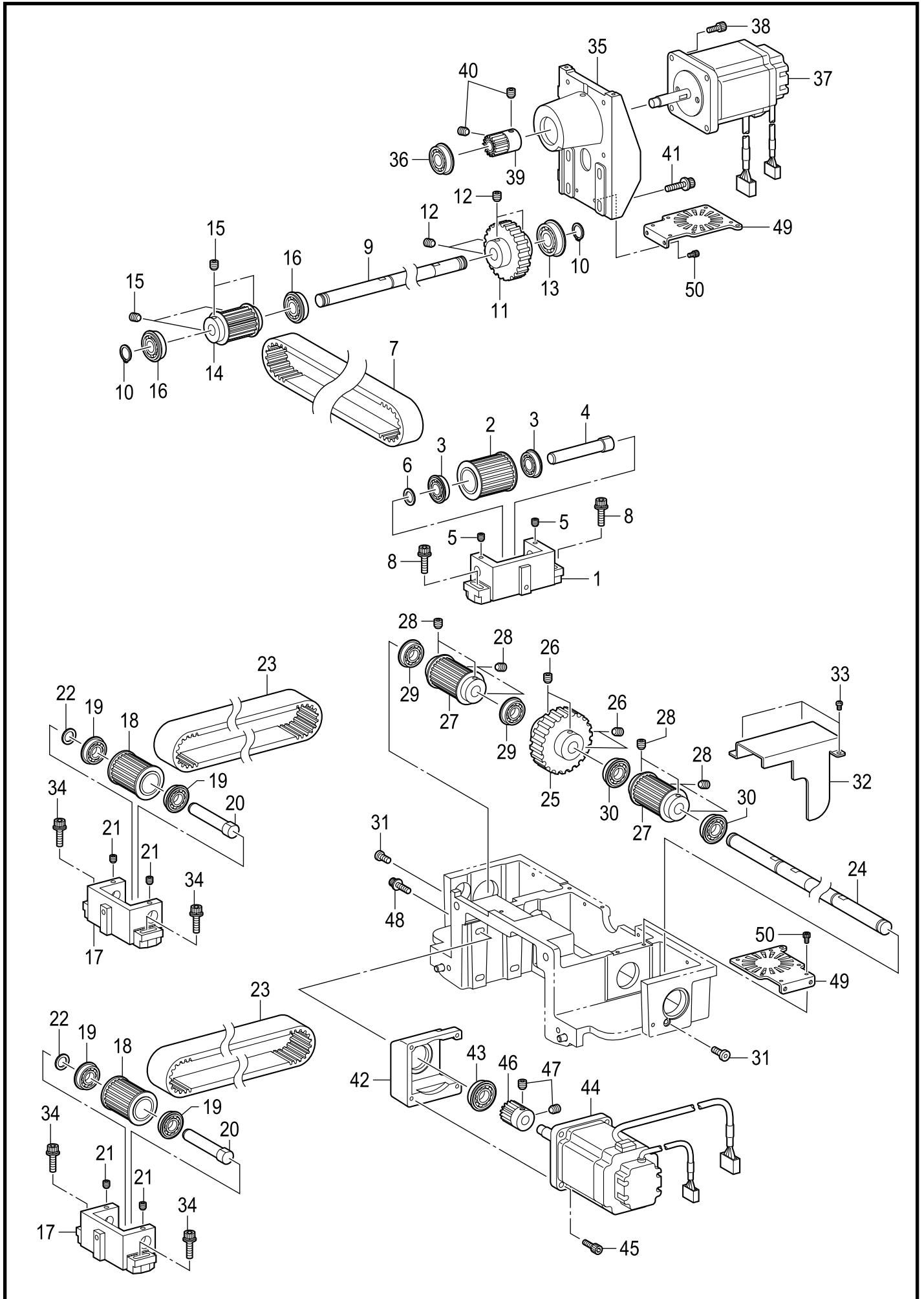

C2. 送り関係 / Feed mechanism

REF.NO	CODE	Q'TY	品名	NAME OF PARTS	RM
1	SA8578001	1	Xプーリーダイ	X-PULLEY BRACKET	
2	SA8579001	1	プーリー-Aクミ	PULLEY A ASSY	
3	SA1283001	2	タマジクウケ6901ZZNR	BALL BEARING, 6901ZZNR	
4	SA8582001	1	プーリー-シテンジク	PULLEY FULCRUM SHAFT	
5	012500536	2	アナヒラ5X5	SET SCREW SOCKET (FT) M5X5	
6	SA8583001	1	プーリー-シテンジクカラ-	PULLEY FULCRUM SHAFT COLLAR	
7	SA8584001	1	X-GTベルト	X-GT BELT	
8	S47270001	2	アナボルトザクミ6X30	BOLT SOCKET (S/P WASHER) M6X30	
9	SA8585001	1	Xクドウジク	DRIVE SHAFT X	
10	048150142	2	トメワジクヨウC15	RETAINING RING EXTERNAL C15	
11	SA8586001	1	Xゲンソクギヤ	GEAR X	
12	012060636	4	アナヒラ6X6	SET SCREW SOCKET (FT) M6X6	
13	SA6674001	1	タマジクウケ6002ZZNR	BALL BEARING 6002ZZNR	
14	SA8587001	1	プーリー-Bクミ	PULLEY B ASSY	
15	012060636	4	アナヒラ6X6	SET SCREW SOCKET (FT) M6X6	
16	076202850	2	Rタマジクウケ6202ZZNR	BALL BEARING RADIAL 6202ZZNR	
17	SA8592001	2	Yプーリーダイ	Y-PULLEY BRACKET	
18	SA8579001	2	プーリー-Aクミ	PULLEY A ASSY	
19	SA1283001	4	タマジクウケ6901ZZNR	BALL BEARING, 6901ZZNR	
20	SA8582001	2	プーリー-シテンジク	PULLEY FULCRUM SHAFT	
21	012500536	4	アナヒラ5X5	SET SCREW SOCKET (FT) M5X5	
22	SA8583001	2	プーリー-シテンジクカラ-	PULLEY FULCRUM SHAFT COLLAR	
23	SA8593001	2	Y-GTベルト	Y-GT BELT	
24	SA8595001	1	Yクドウジク	DRIVE SHAFT Y	
25	SA8596001	1	Yゲンソクギヤ	GEAR Y	
26	012060636	4	アナヒラ6X6	SET SCREW SOCKET (FT) M6X6	
27	SA8587001	2	プーリー-Bクミ	PULLEY B ASSY	
28	012060636	8	アナヒラ6X6	SET SCREW SOCKET (FT) M6X6	
29	SA6674001	2	タマジクウケ6002ZZNR	BALL BEARING 6002ZZNR	
30	076202850	2	Rタマジクウケ6202ZZNR	BALL BEARING RADIAL 6202ZZNR	
31	SA8597001	2	テイトウアナボルト5X12	BOLT SOCKET M5X12	
32	SA8602001	1	Yクドウギヤカバー	COVER GEAR Y	
33	062400816	3	ナベコ4X8	SCREW PAN M4X8	
34	S47270001	4	アナボルトザクミ6X30	BOLT SOCKET (S/P WASHER) M6X30	
35	SA8604001	1	Xモーターブラケット	MOTOR BRACKET X	
36	SA8599001	1	タマジクウケ6201ZZNR	BALL BEARING 6201ZZNR	
37	SA8538001	1	パルスモータXクミ	PULSE MOTOR ASSY X	
38	018501636	4	アナボルト5X16	BOLT SOCKET M5X16	
39	SA8607001	1	Xモーターギヤ	MOTOR GEAR X	
40	012060636	2	アナヒラ6X6	SET SCREW SOCKET (FT) M6X6	
41	S47270001	4	アナボルトザクミ6X30	BOLT SOCKET (S/P WASHER) M6X30	
42	SA8598001	1	Yモーターブラケット	MOTOR BRACKET Y	
43	SA8599001	1	タマジクウケ6201ZZNR	BALL BEARING 6201ZZNR	
44	SA8542001	1	パルスモータYクミ	PULSE MOTOR ASSY Y	
45	018501636	4	アナボルト5X16	BOLT SOCKET M5X16	
46	SA8601001	1	Yモーターギヤ	MOTOR GEAR Y	
47	012060636	2	アナヒラ6X6	SET SCREW SOCKET (FT) M6X6	
48	S47269001	4	アナボルトザクミ6X20	BOLT SOCKET (S/P WASHER) M6X20	
49	SA8694001	2	ファンリツケイタ	FAN BRACKET	
50	018400836	4	アナボルト4X8	BOLT SOCKET M4X8	

C3 . 送り関係 / Feed mechanism

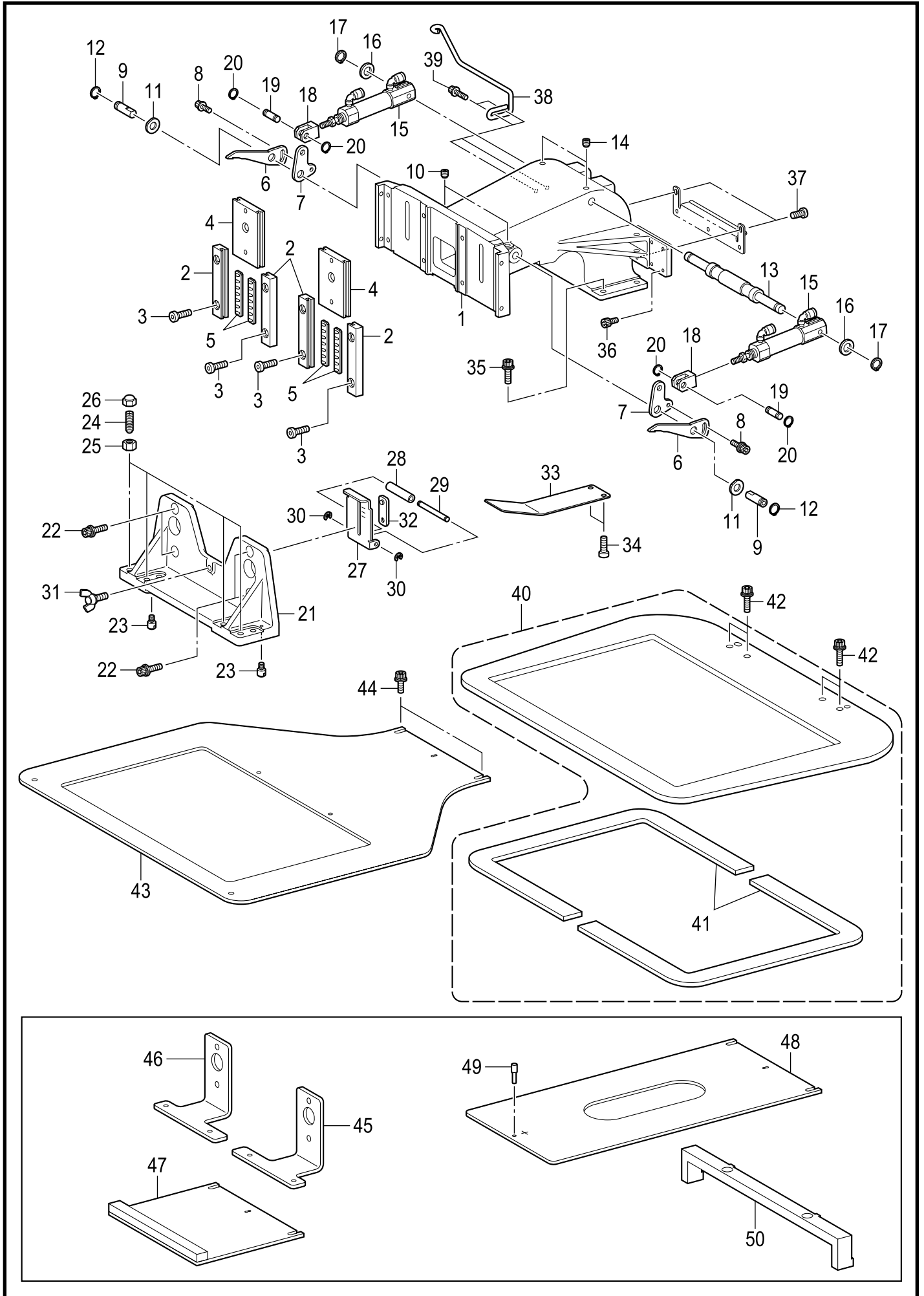

C3. 送り関係 / Feed mechanism

REF.NO	CODE	Q'TY	品名	NAME OF PARTS	RM
1	SA8628001	1	オサエウデ	WORK CLAMP ARM	
2	SA8629001	4	オサエアシアンナイクミ	WORK CLAMP GUIDE ASSY	
3	SA8597001	8	テイトウアナボルト5X12	BOLT SOCKET M5X12	
4	SA8631001	2	オサエアシスライダ	WORK CLAMP SLIDER	
5	SA8632001	4	クロスローラ	CROSS ROLLER	
6	SA8633001	2	オサエアゲレバ-	WORK CLAMP LIFTER LEVER U	
7	SA8634001	2	オサエウデレバ-	WORK CLAMP ARM LEVER	
8	S55479001	2	アナボルトザクミ4X8	BOLT SOCKET (S/P WASHER) M4X8	
9	SA4771001	2	カンケツアゲリンクジク	SHAFT STEPPING CLAMP LIFT LINK	
10	012060636	2	アナヒラ6X6	SET SCREW SOCKET (FT) M6X6	
11	110367001	2	ザガネ	WASHER, PLAIN SPECIAL 8	
12	048080142	2	トメワジクヨウC8	RETAINING RING EXTERNAL C8	
13	SA8635001	1	シリンダ-ジク	CYLINDER SHAFT	
14	012060636	2	アナヒラ6X6	SET SCREW SOCKET (FT) M6X6	
15	SA8636001	2	エアシリンダクミ	AIR CYLINDER ASSY	
16	146354002	2	ザガネ	WASHER, PLAIN 5	
17	048040342	2	トメワE4	RETAINING RING E4	
18	SA4720001	2	シリンダ-ツギテ	CYLINDER JOINT	
19	SA4721001	2	シリンダ-ツギテジク	CYLINDER JOINT SHAFT	
20	048060142	4	トメワジクヨウC6	RETAINING RING EXTERNAL C6	
21	SA8638001	1	オサエアシ	WORK CLAMP	
22	S55485001	4	アナボルトザクミ5X12	BOLT SOCKET (S/P WASHER) M5X12	
23	SA4709001	2	イチギメダンネジ	SHOULDER SCREW	
24	S25475101	4	トメネジ6	SET SCREW, M6X19	
25	021060206	4	2シュナット6	NUT 2 M6	
26	SA8909001	4	ロツカクフクロナツトM6	NUT, CAP M6	
27	SA8640001	1	オサエアシストツパー	WORK CLAMP STOPPER	
28	SA8641001	1	オサエアシストツパー-ゴム	WORK CLAMP STOPPER RUBBER	
29	SA8820001	1	ローラ-シャフト	ROLLER SHAFT	
30	048030342	2	トメワE3	RETAINING RING E3	
31	SA8642001	1	チョウボルト	WING SCREW	
32	SA8643001	1	オサエアシイタナツト	WORK CLAMP PLATE NUT	
33	SA8644001	1	オサエアシイタバネ	WORK CLAMP SPRING	
34	SA8597001	2	テイトウアナボルト5X12	BOLT SOCKET M5X12	
35	S55485001	4	アナボルトザクミ5X12	BOLT SOCKET (S/P WASHER) M5X12	
36	018300836	8	アナボルト3X8	BOLT SOCKET M3X8	
37	062500816	2	ナベコ5X8	SCREW PAN M5X8	
38	SA8645001	1	ホ-スササエ	HOSE SUPPORT	
39	S55481001	2	アナボルトザクミ4X12	BOLT SOCKET (S/P WASHER) M4X12	
40	SA8646001	1	オサエイタクミ	WORK CLAMP ASSY	
41	SA8818001	2	オサエクッション	WORK CLAMP CUSHION	
42	S55487001	4	アナボルトザクミ5X16	BOLT SOCKET (S/P WASHER) M5X16	
43	SA8648001	1	オクリイタ	FEED PLATE	
44	SA8904001	2	アナボルトザクミ5X10L	BOLT SOCKET (S/P WASHER) M5X10L	
			<オプション部品>	<Option parts>	
45	SA8859001	1	オサエアシヘンカンR	WORK CLAMP CONVERSION R	
46	SA8860001	1	オサエアシヘンカンL	WORK CLAMP CONVERSION L	
47	SA8871001	1	オクリイタヘンカンクミ	FEED PLATE CONVERSION ASSY	
48	SA8869001	1	ゲンテンキジュンイタ	ORIGIN STANDARD PLATE	
49	SA5415001	1	ゲンテンキジュンピン	ORIGIN STANDARD PIN	
50	SA8870001	1	Yベ-スイタジグ	BASE PLATE Y POSITION BLOCK	

D1 . 押え上げ関係 / Work clamp lifter mechanism

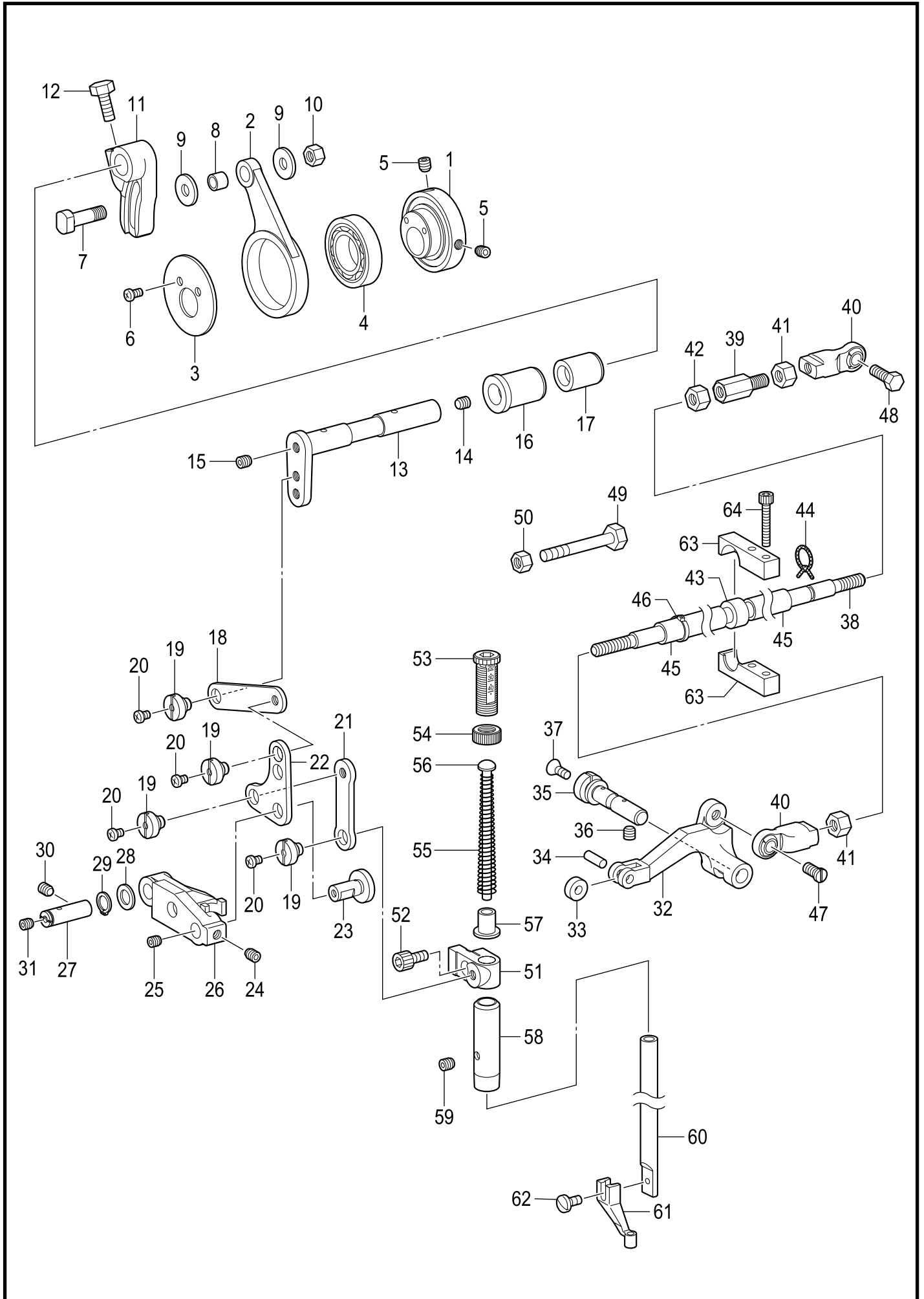

D1. 押え上げ関係 / Work clamp lifter mechanism

REF.NO	CODE	Q'TY	品名	NAME OF PARTS	RM
1	SA4759001	1	カンケツオサエカム	STEPPING CLAMP CAM	
2	SA4760001	1	カンケツオサエレンカン	STEPPING CLAMP CON.ROD	
3	SA4763001	1	カンケツオサエカムザガネ	WASHER STEPPING CLAMP CAM	
4	623033000	1	タマジクウケ6805VV	BALL BEARING, 6805VV	
5	S23651001	2	アナヒラ6X6ホソメ	SET SCREW SOCKET (FT) M6X6	
6	062400616	2	ナベコ4X6	SCREW PAN M4X6	
7	SA4761001	1	カンケツオサエウデコロジク	ROLLER SHAFT STEPPING CLAMP	
8	SA4762001	1	カンケツオサエウデコロ	ROLLER STEPING CLAMP	
9	SA4302001	2	ザガネ	WASHER	
10	021060106	1	1シュナット6	NUT 1 M6	
11	SA4764001	1	カンケツオサエウデR	STEPPING CLAMP ARM R	
12	017061213	1	ボルト6X12	BOLT M6X12	
13	SA4765001	1	カンケツオサエウデF	STEPPING CLAMP ARM F	
14	012060636	1	アナヒラ6X6	SET SCREW SOCKET (FT) M6X6	
15	S23651001	1	アナヒラ6X6ホソメ	SET SCREW SOCKET (FT) M6X6	
16	SA4766001	1	カンケツオサエウデメタルF	BUSH STEPPING CLAMP F	
17	SA4767001	1	カンケツオサエウデメタルR	BUSH STEPPING CLAMP R	
18	SA4768001	1	カンケツレンカンA	STEPPING CLAMP LINK A	
19	SA4769101	4	ダンネジ6	SHOULDER SCREW 6	
20	062300416	4	ナベコ3X4	SCREW PAN M3X4	
21	SA4770001	1	カンケツレンカンB	STEPPING CLAMP LINK B	
22	SA4772001	1	カンケツリンク	STEPPING CLAMP LINK	
23	SA4773001	1	カンケツリンクジク	SHAFT STEPPING CLAMP LINK	
24	012060636	1	アナヒラ6X6	SET SCREW SOCKET (FT) M6X6	
25	012400436	1	アナヒラ4X4	SET SCREW SOCKET (FT) M4X4	
26	SA4777001	1	カンケツアゲリンク	STEPPING CLAMP LIFTER LINK	
27	SA4771001	1	カンケツアゲリンクジク	SHAFT STEPPING CLAMP LIFT LINK	
28	SA2161001	1	ザガネ	WASHER	
29	048080142	1	トメワジクヨウC8	RETAINING RING EXTERNAL C8	
30	012060636	1	アナヒラ6X6	SET SCREW SOCKET (FT) M6X6	
31	012400436	1	アナヒラ4X4	SET SCREW SOCKET (FT) M4X4	
32	SA4779001	1	カンケツアゲレバー	STEPPING CLAMP LIFTER	
33	SA4781001	1	カンケツアゲレバーコロ	ROLLER STEPPING CLAMP LIFTER	
34	141362001	1	エントウコロ	ROLLER	
35	SA4780001	1	カンケツアゲレバージク	SHAFT STEPPING CLAMP LIFTER	
36	012060636	1	アナヒラ6X6	SET SCREW SOCKET (FT) M6X6	
37	S25310101	1	サラネジ4	SCREW, FLAT M4	
38	SA8683001	1	カンケツアゲロッド	STEPPING CLAMP LIFTER ROD	
39	SA4853001	1	カンケツアゲロッドツギテ	JOINT STEPPING CLAMP LIFTER	
40	SA8684001	2	タマツギテクミ	ROUND JOINT ASSY	
41	021060306	2	3シュナット6	NUT 3 M6	
42	SA3227001	1	ナツト6ホソメ	NUT(FT), M6	
43	SA8688001	1	ゴムブッシュ	RUBBER BUSH	
44	SA6572001	1	クミヒモ	WICK L=140	
45	SA8912001	2	ゴムチューブ	RUBBER TUBE	
46	S04159000	1	バンド 1M	BAND 1M	
47	SA8689001	1	シメネジ6X12	SCREW M6X12	
48	017061612	1	ボルト6X16	BOLT M6X16	
49	017065002	1	ボルト6X50	BOLT M6X50	
50	021060106	1	1シュナット6	NUT 1 M6	
51	SA4778001	1	オサエボウダキ	PRESSER BAR CLAMP	
52	018400836	1	アナボルト4X8	BOLT SOCKET M4X8	
53	SA1174001	1	オサエチヨウセツネジM14	PRESSER ADJUSTING SCREW, M14	
54	SA1175001	1	チヨウセツネジナツトM14	ADJUST SCREW NUT	
55	SA5300001	1	オサエバネ	PRESSER BAR SPRING	
56	S10112101	1	オサエバネアンナイ	PRESSER BAR SPRING GUIDE	
57	SA5301001	1	オサエバネカラ	COLLAR PRESSER BAR SPRING	
58	SA2195001	1	オサエボウメタル	PRESSER BAR BUSH	
59	012060536	1	アナヒラ6X5	SET SCREW, SOCKET (FT) M6X5	
60	111466121	1	オサエボウ	PRESSER BAR	
61	S42843001	1	オサエアシA	PRESSER FOOT, A	
62	S13399001	1	シメネジ3.57X12	SCREW, SM3.57X12	
63	SA8690001	2	カンケツアゲロッドササエ	HOLDER STEP-CLAMP LIFTER ROD	
64	018402536	2	アナボルト4X25	BOLT SOCKET M4X25	

D2 . 押え上げ関係 / Work clamp lifter mechanism

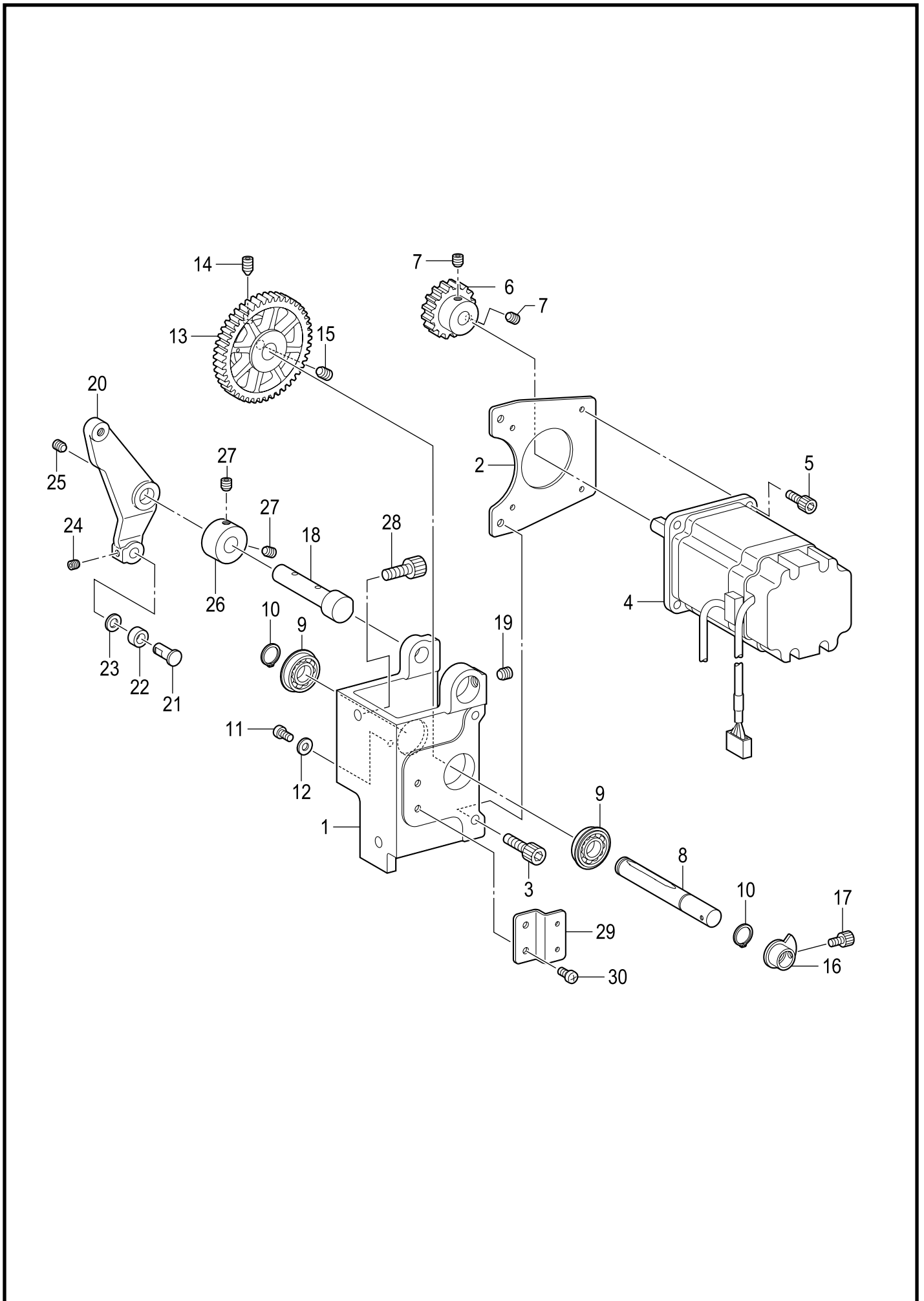

D2. 押え上げ関係 / Work clamp lifter mechanism

REF.NO	CODE	Q'TY	品名	NAME OF PARTS	RM
1	SA4741101	1	モーターブラケット	MOTOR BRACKET	
2	SA4742001	1	オサエアゲモーターイタ	WORK CLAMP MOTOR PLATE	
3	018501036	2	アナボルト5X10	BOLT SOCKET M5X10	
4	SA4826501	1	パルスモーターPクミ	PULSE MOTOR ASSY P	
5	018401036	4	アナボルト4X10	BOLT SOCKET M4X10	
6	SA4743001	1	オサエアゲクドウギヤ	WORK CLAMP DRIVING GEAR	
7	012060636	2	アナヒラ6X6	SET SCREW SOCKET (FT) M6X6	
8	SA4744001	1	オサエアゲシテンジク	WORK CLAMP FULCRUM SHAFT	
9	SA4647001	2	タマジクウケ6900ZZNR	BALL BEARING 6900ZZNR	
10	048100142	2	トメワジクヨウC10	RETAINING RING EXTERNAL C10	
11	062400616	1	ナベコ4X6	SCREW PAN M4X6	
12	025040236	1	ヒラザガネチュウ4	WASHER PLAIN M 4	
13	SA4745001	1	オサエアゲカムギヤ	WORK CLAMP CAM GEAR	
14	016061031	1	アナトガリ6X10	SET SCREW SOCKET (CN) M6X10	
15	012060636	1	アナヒラ6X6	SET SCREW SOCKET (FT) M6X6	
16	SA4747001	1	オサエゲンテンドグ	WORK CLAMP H-POSITION DOG	
17	018400636	1	アナボルト4X6	BOLT SOCKET M4X6	
18	SA4748101	1	オサエアゲレバージク	WORK CLAMP LEVER SHAFT	
19	012060636	1	アナヒラ6X6	SET SCREW SOCKET (FT) M6X6	
20	SA6210001	1	カンケツクドウレバー	STEPPING W-CLAMP DRIVING LEVER	
21	SA3441001	1	オサエアゲコロジク	W-CLAMP LIFTER ROLLER SHAFT	
22	070696800	1	Rタマジクウケ696ZZ	BALL BEARING RADIAL 696ZZ	
23	109763001	1	ザガネ	WASHER	
24	012500536	1	アナヒラ5X5	SET SCREW SOCKET (FT) M5X5	
25	012060636	1	アナヒラ6X6	SET SCREW SOCKET (FT) M6X6	
26	SA4757101	1	セットカラー	SET SCREW COLLAR	
27	012060636	2	アナヒラ6X6	SET SCREW SOCKET (FT) M6X6	
28	018061236	2	アナボルト6X12	BOLT SOCKET M6X12	
29	SA4753001	1	オサエアゲセンサーイタ	WORK CLAMP SENSOR PLATE	
30	062400616	2	ナベコ4X6	SCREW PAN M4X6	

E . 下軸関係 / Lower shaft mechanism

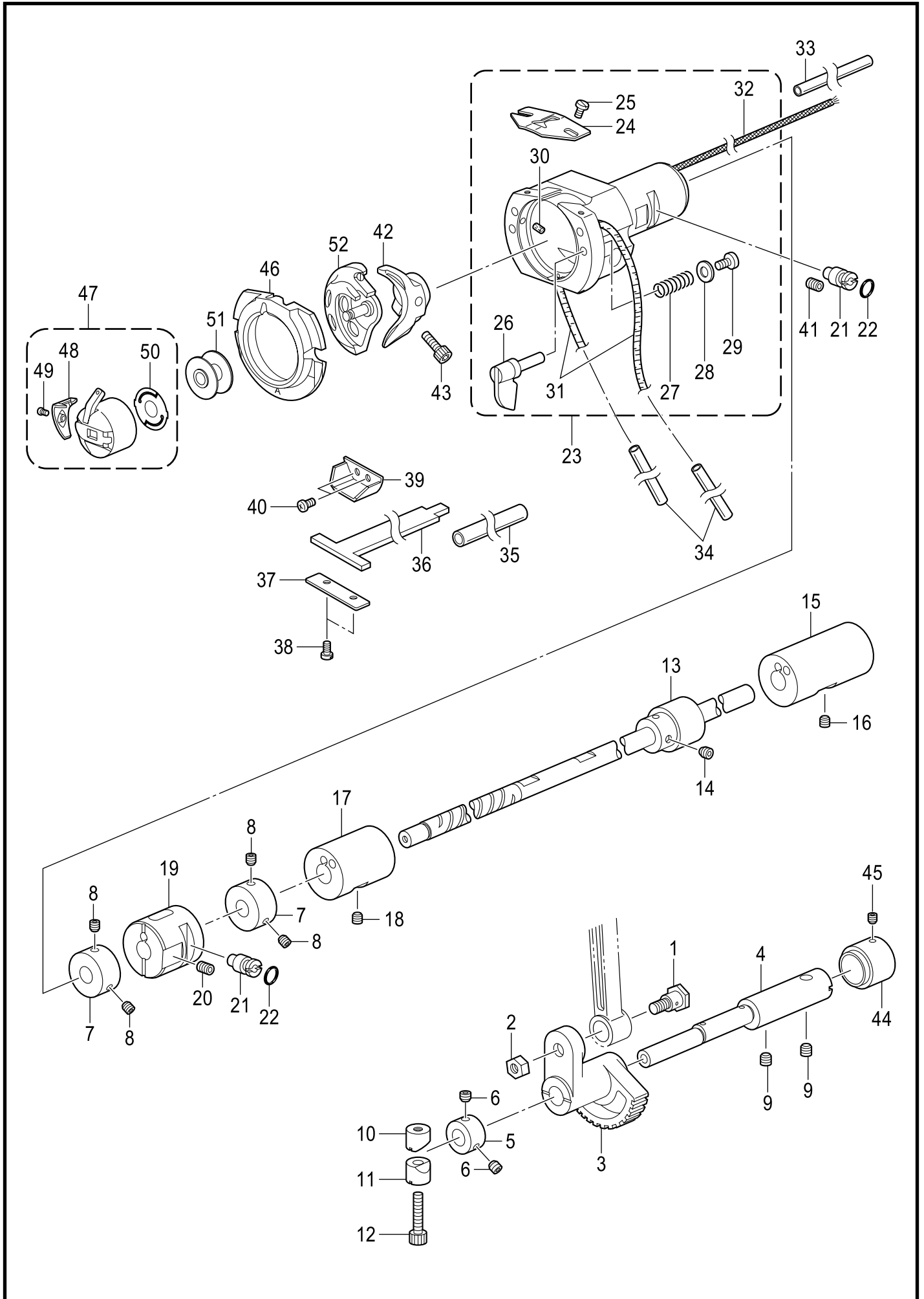

BAS-342G-305

E. 下軸関係 / Lower shaft mechanism

REF.NO	CODE	Q'TY	品名	NAME OF PARTS	RM
1	SA3226001	1	クランクロッドダンネジ	SHOULDER SCREW	
2	SA3227001	1	ナツト6ホソメ	NUT(FT), M6	
3	SA3228101	1	ヨウドウギヤ	ROCK GEAR	
4	SA4782001	1	ヨウドウギヤジク	ROCK GEAR SHAFT	
5	SA3231001	1	セツトカラ- B	SET SCREW COLLAR, B	
6	012060536	2	アナヒラ6X5	SET SCREW, SOCKET (FT) M6X5	
7	SA8695001	2	セツトカラ-	SET SCREW COLLAR	
8	S23651001	4	アナヒラ6X6ホソメ	SET SCREW SOCKET (FT) M6X6	
9	012060636	2	アナヒラ6X6	SET SCREW SOCKET (FT) M6X6	
10	SA8696001	1	ピンチスリーブA	PINCH SLEEVE A	
11	SA8697001	1	ピンチスリーブB	PINCH SLEEVE B	
12	018402036	1	アナボルト4X20	BOLT SOCKET M4X20	
13	SA8698001	1	シタジククミ	LOWER SHAFT ASSY	
14	012500536	1	アナヒラ5X5	SET SCREW SOCKET (FT) M5X5	
15	SA8701001	1	シタジクメタル	LOWER SHAFT BUSH	
16	012060636	1	アナヒラ6X6	SET SCREW SOCKET (FT) M6X6	
17	SA8702001	1	シタジクナカメタル	LOWER SHAFT M BUSH	
18	012060636	1	アナヒラ6X6	SET SCREW SOCKET (FT) M6X6	
19	SA8703001	1	シタジクチョウセイメタル	LOWER SHAFT A-BUSH	
20	012061036	1	アナヒラ6X10	SET SCREW SOCKET (FT) M6X10	
21	SA3238101	2	カマチヨウセツジク	ADJUSTING STUD	
22	081003670	2	リングPW3	O RING PW3	
23	SA8705001	1	オオカマタイクミ	SHUTTLE RACE BASE ASSY	
24	S02429201	1	カマイトアンナイ	SHUTTLE RACE THREAD GUIDE	
25	SA4199001	2	シメネジ3X4	SCREW M3X4	
26	SA3241001	2	オオカマトリツケツメ	S-RACE BASE SETTING CLAW	
27	152684101	2	オオカマトリツケバネ	COMPRESSION SPRING	
28	026030136	2	ヒラザガネコガタ3	WASHER PLAIN S 3	
29	062300616	2	ナベコ3X6	SCREW PAN M3X6	
30	153050000	2	オオカマタイフェルト	S-RACE BASE FELT	
31	SA8707001	2	フェルト	FELT	
32	SA9004001	1	クミヒモ6X6	WICK 6X6	
33	SA8709001	1	ビニルチューブ	OIL TUBE	
34	SA8710001	2	ビニルチューブ	OIL TUBE	
35	SA8711001	1	ビニルチューブ	OIL TUBE	
36	SA8712101	1	フェルト	FELT	
37	SA8713001	1	フェルトササエ	FELT HOLDER	
38	S44924001	2	シメネジM3X5.5	SCREW M3X5.5	
39	SA3274101	1	フェルトオサエ	FELT HOLDER	
40	S47307001	2	シメネジ3X4	SCREW, M3X4	
41	012061036	1	アナヒラ6X10	SET SCREW SOCKET (FT) M6X10	
42	SA3284101	1	ドライバーD	DRIVER D	
43	018501236	1	アナボルト5X12	BOLT SOCKET M5X12	
44	SA3283101	1	セツトカラ-R	SET SCREW COLLAR, R	
45	012500536	1	アナヒラ5X5	SET SCREW SOCKET (FT) M5X5	
46	152686201	1	オオカマB	SHUTTLE RACE BASE B	
47	S59221201	1	ボビンケ-スクミLC	BOBBIN CASE ASSY LC	
48	S48664001	1	ケ-スチヨウシバネAN	TENSION SPRING, AN	
49	S16492101	1	ボビンケ-スバネネジ	BOBBIN CASE SPRING SCREW	
50	S15667001	1	クウテンボウシバネ	ANTI-SPIN SPRING	
51	S44633001	1	ボビンLAN	BOBBIN LAN	
52	SA8197101	1	SA8196カマハコクミ	SHUTTLE HOOK ASSY W/BOXSA8196	

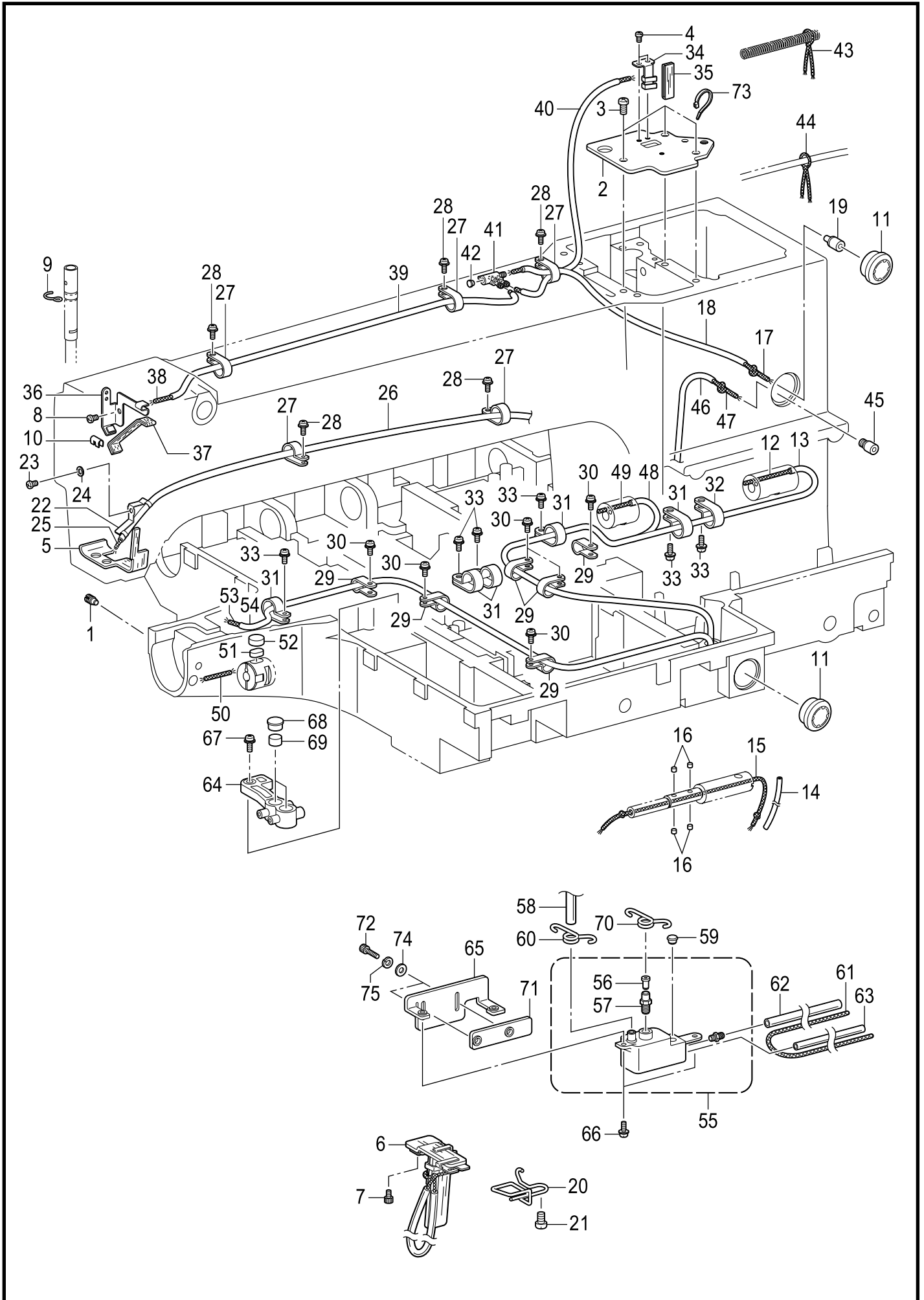

F. 給油潤滑関係 / Lubrication

REF.NO	CODE	Q'TY	品名	NAME OF PARTS	RM
1	SA3244001	1	トメネジ	SET SCREW	
2	SA4785101	1	クランクカバー	CRANK COVER	
3	062061016	3	ナベコ6X10	SCREW PAN M6X10	
4	062400616	2	ナベコ4X6	SCREW PAN M4X6	
5	SA4786101	1	スイアゲフェルト	FELT	
6	SA8714001	1	ギヤフェルトクミ	GEAR FELT ASSY	
7	018400636	2	アナボルト4X6	BOLT SOCKET M4X6	
8	062400616	1	ナベコ4X6	SCREW PAN M4X6	
9	SA6087001	1	ハリボウヒモササエ	WICK SUPPORT	
10	104567101	1	クミヒモササエ	WICK SUPPORT	
11	152948001	2	オイルポットマド	OIL GAUGE WINDOW	
12	SA8783001	1	クミヒモ6X6	WICK 6X6	
13	SA8784001	1	ビニルチューブ	OIL TUBE	
14	SA5072001	1	オイルチューブ	OIL TUBE L=120	
15	SA6578001	1	クミヒモ6X6	WICK 6X6 L=300	
16	S09043000	4	フェルト	FELT	
17	S49982000	1	クミヒモ4X4	WICK, 4X4 L=400	
18	S48189000	1	オイルチューブ	OIL TUBE, L=280	
19	SA5339101	1	オイルクチパイプ	OIL FEEDING PIPE	
20	SA4789101	1	シタジクキウユササエB	LOWER SHAFT WICK SUPPORT B	
21	062060816	1	ナベコ6X8	SCREW PAN M6X8	
22	145547001	1	チューブホルダ	TUBE HOLDER	
23	062400616	1	ナベコ4X6	SCREW PAN M4X6	
24	026040136	1	ヒラザガネコガタ4	WASHER PLAIN S 4	
25	SA8717001	1	クミヒモ4X4	WICK 4X4	
26	SA8718001	1	ビニルチューブ	OIL TUBE	
27	525567000	5	コードホルダ#8	CORD HOLDER #8	
28	0A5401006	5	+ナベザクミ4X10DB	SCREW PAN (S/P WASHER) M4X10	
29	525567000	6	コードホルダ#8	CORD HOLDER #8	
30	0A5401006	6	+ナベザクミ4X10DB	SCREW PAN (S/P WASHER) M4X10	
31	552907000	5	コードホルダ#10	CORD HOLDER #10	
32	554482000	1	コードホルダ#12	CORD HOLDER #12	
33	0A5401006	6	+ナベザクミ4X10DB	SCREW PAN (S/P WASHER) M4X10	
34	SA4787001	1	クランクキウユイタ	CRANK WICK PLATE	
35	SA5294001	1	ヒラクミヒモ	FLAT WICK L=90	
36	SA4788001	1	テンピンキウユササエ	WICK SUPPORT	
37	SA6593001	1	ヒラクミヒモ	FLAT WICK L=180	
38	SA8720001	1	クミヒモ3X3	WICK 3X3	
39	SA8721001	1	ビニルチューブ	OIL TUBE	
40	SA6576001	1	ビニルチューブ	OIL TUBE L=210	
41	S38265000	1	ターミナルL	TERMINAL, L	
42	142274101	1	ゴムセン4.2	RUBBER CAP, 4.2	
43	SA6572001	1	クミヒモ	WICK L=140	
44	SA6572001	1	クミヒモ	WICK L=140	
45	SA8722001	1	オイルクチパイプ	OIL FEEDING PIPE	
46	SA8723001	1	ビニルチューブ	OIL TUBE	
47	SA8724001	1	クミヒモ6X6	WICK 6X6	
48	SA8725001	1	ビニルチューブ	OIL TUBE	
49	SA8726001	1	クミヒモ6X6	WICK 6X6	
50	SA8727001	1	クミヒモ6X6	WICK 6X6	
51	SA8728001	1	タンクフェルト	FELT	
52	SA8729001	1	タンクフェルト	FELT	
53	SA8708001	1	クミヒモ6X6	WICK 6X6	
54	SA8785001	1	ビニルチューブ	OIL TUBE	
55	SA8732001	1	サブタンククミ	SUB-TANK ASSY	
56	SA3060001	1	バルブパツキン	VALVE PACKING	
57	SA3040001	1	オイルクチ	OIL FEEDING PIPE	
58	SA8733001	1	ビニルチューブ	OIL TUBE	
59	104450101	1	ゴムセン8	RUBBER CAP, 8	
60	SA3055101	1	チューブストツパー	TUBE CLIP	
61	SA8734001	1	フェルト	FELT	
62	SA8735001	1	ビニルチューブ	OIL TUBE	
63	SA8786001	1	ビニルチューブ	OIL TUBE	

F. 給油潤滑関係 / Lubrication

REF.NO	CODE	Q'TY	品名	NAME OF PARTS	RM
64	SA3946001	1	キュウユタ-ミナル	OIL TERMINAL	
65	SA8736001	1	キュウユイタ	OIL PLATE	
66	0A5401006	2	+ナベザクミ4X10DB	SCREW PAN (S/P WASHER) M4X10	
67	0A5401006	1	+ナベザクミ4X10DB	SCREW PAN (S/P WASHER) M4X10	
68	SA2929001	2	ゴムセン12.5	RUBBER CAP, 12.5	
69	S38266000	2	カマジクフエルト	ROTARY HOOK SHAFT FELT	
70	SA3055101	1	チューブストツパー	TUBE CLIP	
71	SA4650001	1	Yセンサーイタ	Y-SENSOR PLATE	
72	018402036	2	アナボルト4X20	BOLT SOCKET M4X20	
73	S04159000	1	バンド1M	BAND 1M	
74	025040236	2	ヒラザガネチュウ4	WASHER PLAIN M 4	
75	028040246	2	バネザガネ2-4	WASHER SPRING 2-4	

G. 糸通し関係 / Threading mechanism

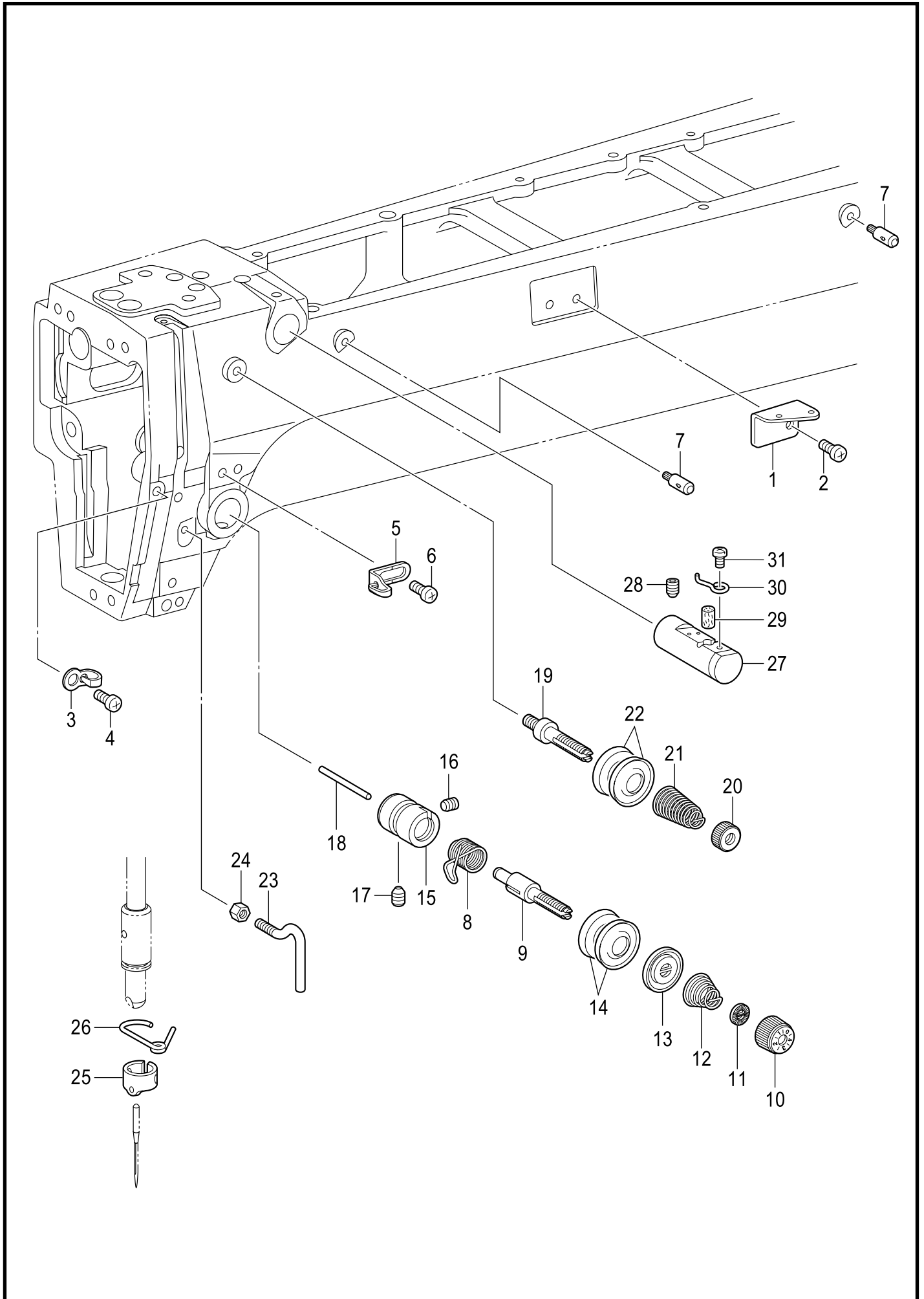

G. 糸通し関係 / Threading mechanism

REF.NO	CODE	Q'TY	品名	NAME OF PARTS	RM
1	SA3250001	1	ア-ムイトミチA	ARM THREAD GUIDE, A	
2	062500616	1	ナベコ5X6	SCREW PAN M5X6	
3	SA4333001	1	ア-ムイトミチB	ARM THREAD GUIDE, B	
4	062500616	1	ナベコ5X6	SCREW PAN M5X6	
5	SA6391001	1	ア-ムイトミチC	ARM THREAD GUIDE C	
6	062500616	1	ナベコ5X6	SCREW PAN M5X6	
7	153049001	2	ウワイトアンナイボウ	UPPER THREAD GUIDE STUD	
8	144588301	1	イトトリバネB	THREAD TAKE-UP SPRING B	
9	SA3255001	1	イトチヨウシボウ	TENSION STUD	
10	S31032001	1	イトチヨウシナツト	TENSION NUT	
11	S12441001	1	チヨウシバネウエザガネ	WASHER	
12	107606101	1	イトチヨウシバネ	TENSION SPRING H	
13	159805001	1	イトチヨウシサラオサエ	TENSION DISC PRESSER	
14	145446001	2	イトチヨウシサラ	DISC, TENSION	
15	SA3254001	1	イトチヨウシダイ	TENSION BRACKET	
16	100402004	1	トメネジ3.57	SET SCREW, SM3.57	
17	SA4143001	1	アナトメネジ6	SET SCREW, (FT) M6X6	
18	S12699000	1	イトユルメピン	TENSION RELEASE PIN	
19	SA3256001	1	イトチヨウシボウA	TENSION STUD, A	
20	100136001	1	イトチヨウシナツト	TENSION NUT	
21	SA4146101	1	フクチヨウシバネ	SUB TENSION SPRING	
22	145446001	2	イトチヨウシサラ	DISC, TENSION	
23	SA8691001	1	ア-ムイトカケ	THREAD GUIDE ARM	
24	021400306	1	3シュナツト4	NUT 3 M4	
25	SA3257101	1	ハリボウイトアンナイA	NEEDLE BAR THREAD GUIDE, A	
26	SA3258001	1	ハリボウメタルDイトアンナイ	N-BAR BUSH THREAD GUIDE, D	
27	152881001	1	エキレイタイクミ	NEEDLE COOLER ASSY	
28	012060636	1	アナヒラ6X6	SET SCREW SOCKET (FT) M6X6	
29	152883000	1	フェルト8X15.5	FELT, 8X15.5	
30	152884001	1	エキレイイトカケ	NEEDLE COOLER THREAD GUIDE	
31	062670412	1	ナベコ357-40X4	SCREW PAN SM3.57-40X4	

H. 糸巻関係 / Bobbin winder mechanism

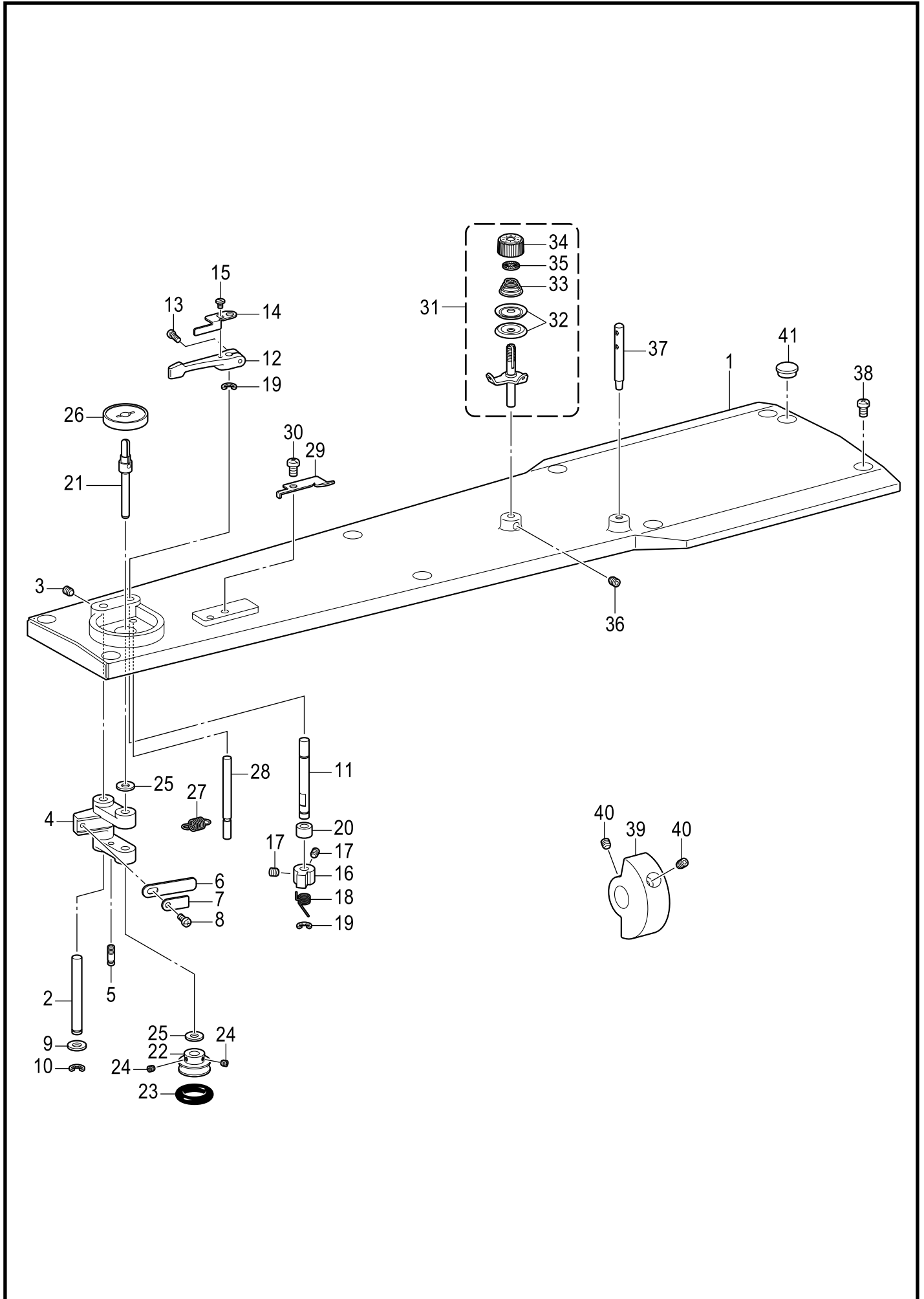

H. 糸巻関係 / Bobbin winder mechanism

REF.NO	CODE	Q'TY	品名	NAME OF PARTS	RM
1	SA8650001	1	ウワフタ	TOP COVER	
2	SA3290001	1	イトマキレバージク	SHAFT, BW-LEVER	
3	012500536	1	アナヒラ5X5	SET SCREW SOCKET (FT) M5X5	
4	SA3291001	1	イトマキレバー	BOBBIN WINDER LEVER	
5	SA4171001	1	バネカケ	SPRING HOOK	
6	152936001	1	イタバネ	PLATE SPRING	
7	152937001	1	ザガネ	WASHER	
8	062350616	1	ナベコ35X6	SCREW PAN M3.5X6	
9	159486001	1	ザガネ	WASHER	
10	048050342	1	トメワE5	RETAINING RING E5	
11	SA3293001	1	イトマキツメジク	STUD B-WINDER CLAW	
12	SA1984001	1	ボビンオサエウデ	BOBBIN PRESSER ARM	
13	062401216	1	ナベコ4X12	SCREW PAN M4X12	
14	SA3294001	1	ボビンオサエ	BOBBIN PRESSER	
15	S23418002	1	シメネジ4X5	SCREW M4X5	
16	SA3295001	1	イトマキツメ	CLAW, B-WINDER	
17	012400436	2	アナヒラ4X4	SET SCREW SOCKET (FT) M4X4	
18	S10438001	1	イトマキツメネジリバネ	SPRING, TWIST	
19	048050342	2	トメワE5	RETAINING RING E5	
20	SA4796001	1	スペーサーカラー	SPACER COLLER	
21	SA3296001	1	イトマキジク	BOBBIN WINDER SHAFT	
22	SA3297001	1	イトマキクルマ	WHEEL, B-WINDER	
23	120448001	1	ゴムワ	BOBBIN WINDER RUBBER BAND	
24	012400436	2	アナヒラ4X4	SET SCREW SOCKET (FT) M4X4	
25	159486001	2	ザガネ	WASHER	
26	SA1988001	1	ボビンウケ	BOBBIN SUPPORT	
27	S10268001	1	イトマキレバーヒキバネ	SPRING	
28	SA3298001	1	ストツパジク	STPPER SHAFT, B-WINDER	
29	SA3299001	1	メス	KNIFE	
30	062500616	1	ナベコ5X6	SCREW PAN M5X6	
31	SA1994101	1	イトマキチヨウシクミ	BOBBIN WINDER TENSION ASSY	
32	145446002	2	イトチヨウシサラ	DISC, TENSION	
33	100401022	1	イトチヨウシバネ	TENSION SPRING	
34	S31032001	1	イトチヨウシナツト	TENSION NUT	
35	S12441001	1	チヨウシバネウエザガネ	WASHER	
36	012500536	1	アナヒラ5X5	SET SCREW SOCKET (FT) M5X5	
37	SA1359001	1	イトタテボウ	SPOOL PIN	
38	062061016	6	ナベコ6X10	SCREW PAN M6X10	
39	SA4797101	1	イトマキドウリン	DRIVING WHEEL B-WINDER	
40	S23651001	2	アナヒラ6X6ホソメ	SET SCREW SOCKET (FT) M6X6	
41	117934001	1	ゴムセン13.5	RUBBER CAP, 13.5	

J. 糸切り関係 / Thread trimmer mechanism

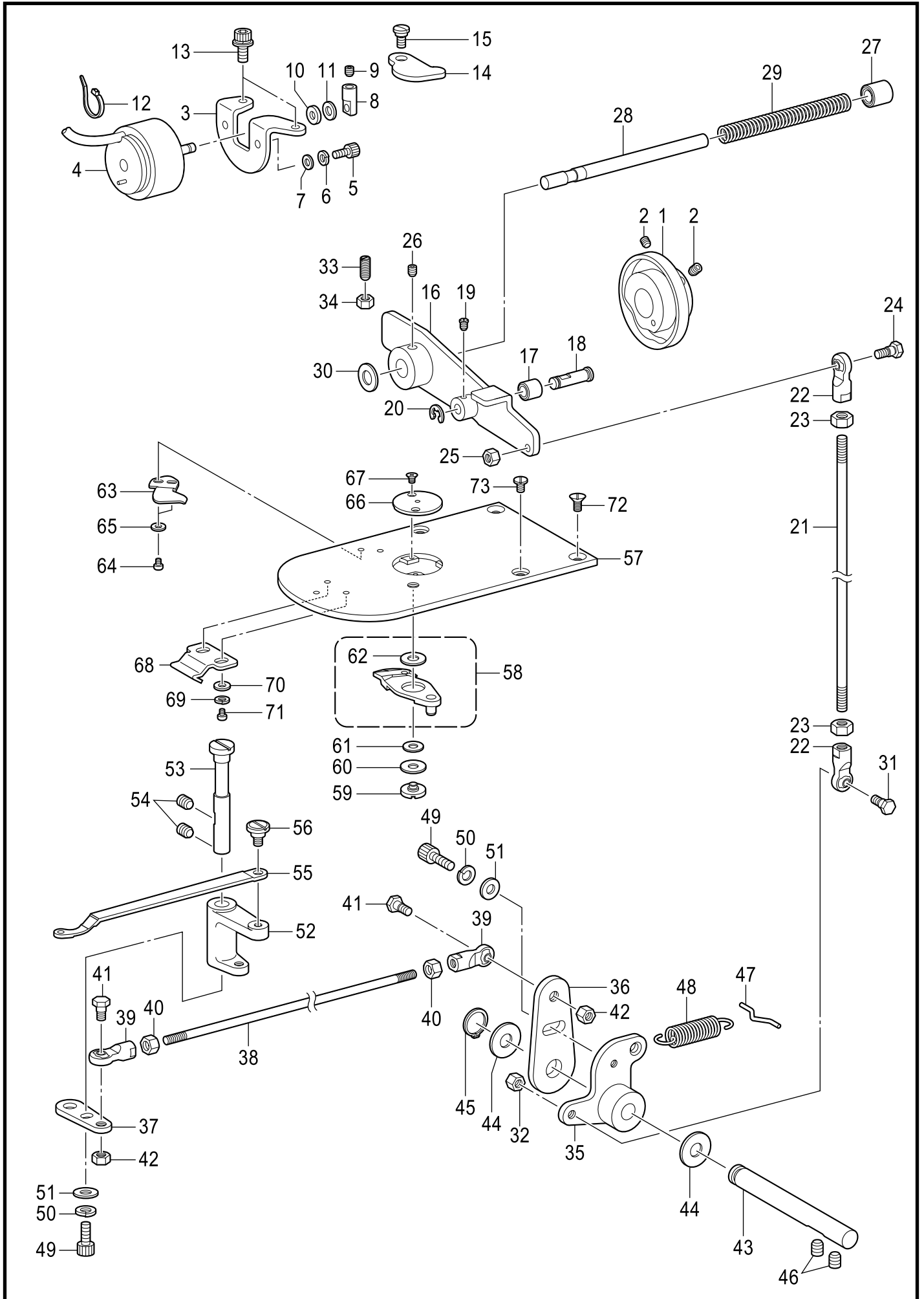

BAS-342G-403

J. 糸切り関係 / Thread trimmer mechanism

REF.NO	CODE	Q'TY	品名	NAME OF PARTS	RM
1	SA3301101	1	イトキリカム	THREAD TRIMMER CAM	
2	S23651001	2	アナヒラ6X6ホソメ	SET SCREW SOCKET (FT) M6X6	
3	SA4798001	1	ソレノイドリツケイタ	SETTING PLATE SOLENOID	
4	SA5135101	1	イトキリソレノイド	THREAD TRIMMER SOLENOID	
5	017400802	2	ボルト4X8	BOLT M4X8	
6	028040246	2	バネザガネ2-4	WASHER SPRING 2-4	
7	026040236	2	ヒラザガネミガキ4	WASHER PLAIN M 4	
8	SA3307001	1	ソレノイドレバー	SOLENOID LEVER	
9	012400436	1	アナヒラ4X4	SET SCREW SOCKET (FT) M4X4	
10	154599000	1	ソレノイドクツシヨン	SOLENOID CUSHION	
11	S02652001	1	ザガネ	WASHER	
12	S04159000	1	バンド1M	BAND 1M	
13	S55484002	2	アナボルトザクミ5X10	BOLT SOCKET (S/P WASHER) M5X10	
14	SA4799001	1	クドウレバー-オシレバー	PUSHING LEVER D-LEVER	
15	SA3306001	1	ダンネジ7-3	SHOULDER SCREW, 7-3	
16	SA3309101	1	イトキリクドウレバー	TR-DRIVING LEVER	
17	SA3310001	1	イトキリコロ	COLLAR, TR-TRIMMER	
18	SA3311001	1	イトキリコロジク	COLLAR SHAFT	
19	S46903001	1	アタマツキトメネジ4X5	SET SCREW, M4X5	
20	048040342	1	トメワE4	RETAINING RING E4	
21	SA3315001	1	イトキリロッドV	THREAD TRIMMER ROD V	
22	S32465101	2	タマツギテクミ	BALL JOINT ASSY	
23	021060106	2	1シュナット6	NUT 1 M6	
24	S32462001	1	タマツギテダンネジB	SHOULDER SCREW, B; M6	
25	021060306	1	3シュナット6	NUT 3 M6	
26	S23651001	1	アナヒラ6X6ホソメ	SET SCREW SOCKET (FT) M6X6	
27	231071001	1	メタル8X15	BUSH, 8X15	
28	SA3312201	1	クドウレバー-アンナイジク	GUIDE SHAFT	
29	SA3313101	1	クドウジクバネ	SPRING, COMPRESSION	
30	154596000	1	イトキリカムレバー-クツシヨン	CUSHION	
31	S32462001	1	タマツギテダンネジB	SHOULDER SCREW, B; M6	
32	021060306	1	3シュナット6	NUT 3 M6	
33	S25475101	1	トメネジ6	SET SCREW, M6X19	
34	021060106	1	1シュナット6	NUT 1 M6	
35	SA4546001	1	イトキリレバー-V	THREAD TRIMMER LEVER V	
36	SA3317001	1	イトキリレバー-H	THREAD TRIMMER LEVER H	
37	SA8652001	1	イドウハレバー-D	MOVING KNIFE LEVER	
38	SA8654001	1	イトキリロッドH	THREAD TRIMMER ROD H	
39	S32465101	2	タマツギテクミ	BALL JOINT ASSY	
40	021060106	2	1シュナット6	NUT 1 M6	
41	S32462001	2	タマツギテダンネジB	SHOULDER SCREW, B; M6	
42	021060306	2	3シュナット6	NUT 3 M6	
43	SA3319101	1	イトキリレバー-ジク	SHAFT TR-TRIMMER LEVER	
44	SA4545001	2	カンザ	SPACER	
45	048080142	1	トメワジクヨウC8	RETAINING RING EXTERNAL C8	
46	012060636	2	アナヒラ6X6	SET SCREW SOCKET (FT) M6X6	
47	SA8655001	1	バネカケ	SPRING HOOK	
48	SA3321001	1	イトキリモシバネ	SPRING, EXTENSION	
49	018501236	2	アナボルト5X12	BOLT SOCKET M5X12	
50	028050246	2	バネザガネ2-5	WASHER SPRING 2-5	
51	146354002	2	ザガネ	WASHER, PLAIN 5	
52	SA8656001	1	イドウハレバー	MOVING KNIFE LEVER	
53	SA8657001	1	イドウハレバー-ジク	SHAFT MOVABLE KNIFE LEVER	
54	012060636	2	アナヒラ6X6	SET SCREW SOCKET (FT) M6X6	
55	SA8658101	1	イドウハレンカン	M-KNIFE CONNECTING PLATE	
56	SA4354001	1	ダンネジ6-1.8	SHOULDER SCREW, 6-1.8	
57	SA5157101	1	ハリイタA	NEEDLE PLATE A	
58	SA6596001	1	イドウハフセット	MOVABLE KNIFE SET F	
59	SA4518001	1	イドウハダンネジ	MOVABLE KNIFE SHOULDER SCREW	
60	SA4519001	1	スラストザガネ	THRUST WASHER	
61	S00705001	1	イドウハカラ	MOVABLE KNIFE COLLAR	
62	SA6397001	1	イドウハカンザ0.2	M-KNIFE SPACER T0.2	
62	SA3334001	1	イドウハカンザ0.3	M-KNIFE SPACER T0.3	

J. 糸切り関係 / Thread trimmer mechanism

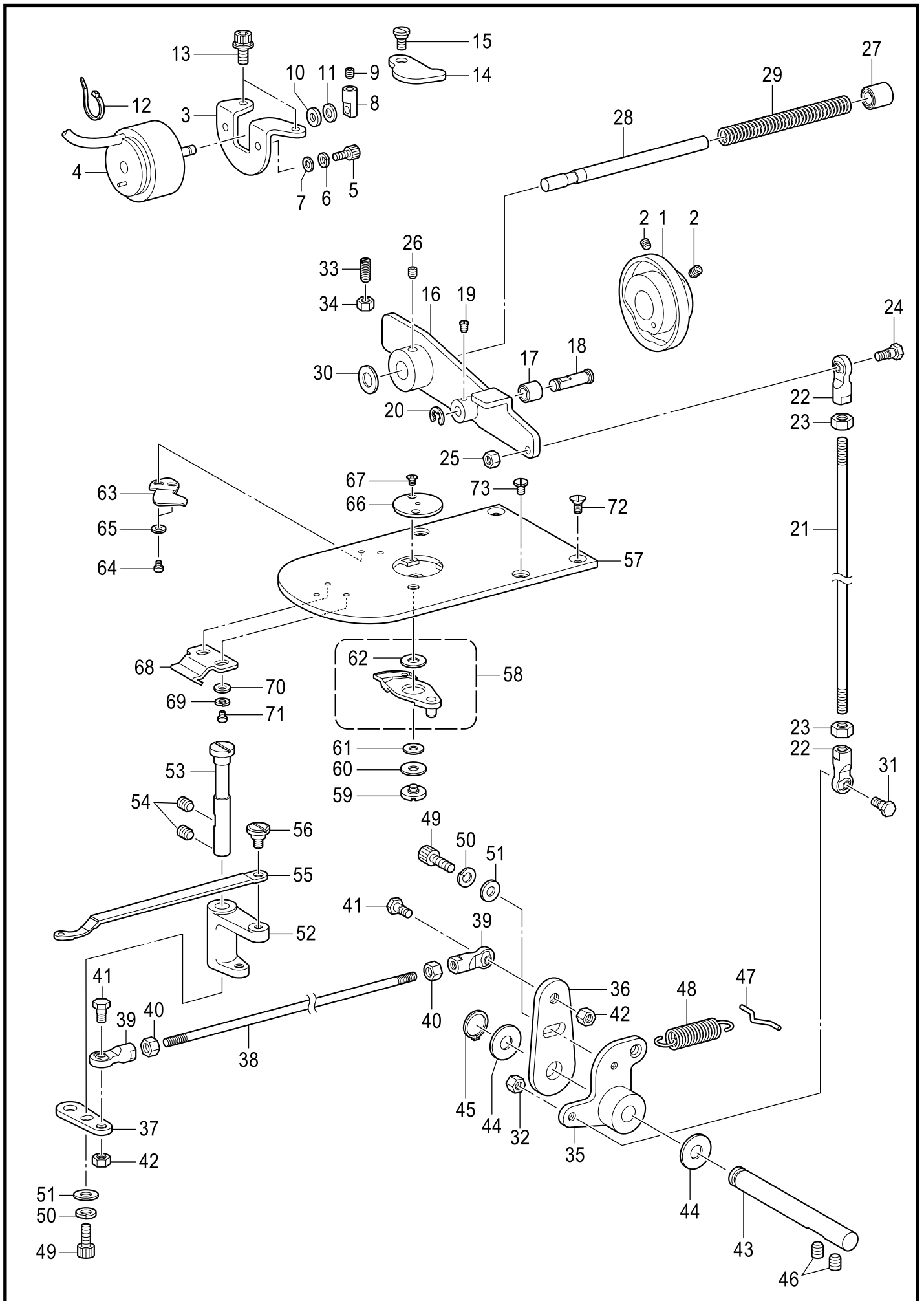

J. 糸切り関係 / Thread trimmer mechanism

REF.NO	CODE	Q'TY	品名	NAME OF PARTS	RM
62	SA6398001	1	イドウハカンザ0.4	M-KNIFE SPACER T0.4	
63	SA7944001	1	コテイハFL	FIXED KNIFE FL	
64	062300416	2	ナベコ3X4	SCREW PAN M3X4	
65	025030236	2	ヒラザガネチュウ3	WASHER PLAIN M 3	
66	SA3336101	1	ハリアナイタ2.4C0.4	NEEDLE HOLE PLATE 2.4C0.4	
67	100360003	2	サラネジ2.38	SCREW	
68	SA6273101	1	オオカマカバーフツクU	SHUTTLE RACE COVER HOOK U	
69	028030246	2	バネザガネ2-3	WASHER SPRING 2-3	
70	025030236	2	ヒラザガネチュウ3	WASHER PLAIN M 3	
71	062300416	2	ナベコ3X4	SCREW PAN M3X4	
72	S25310101	2	サラネジ4	SCREW, FLAT M4	
73	SA3538001	2	シメネジ4X8	SCREW, M4X8	

K. 糸払い関係 / Thread wiper mechanism

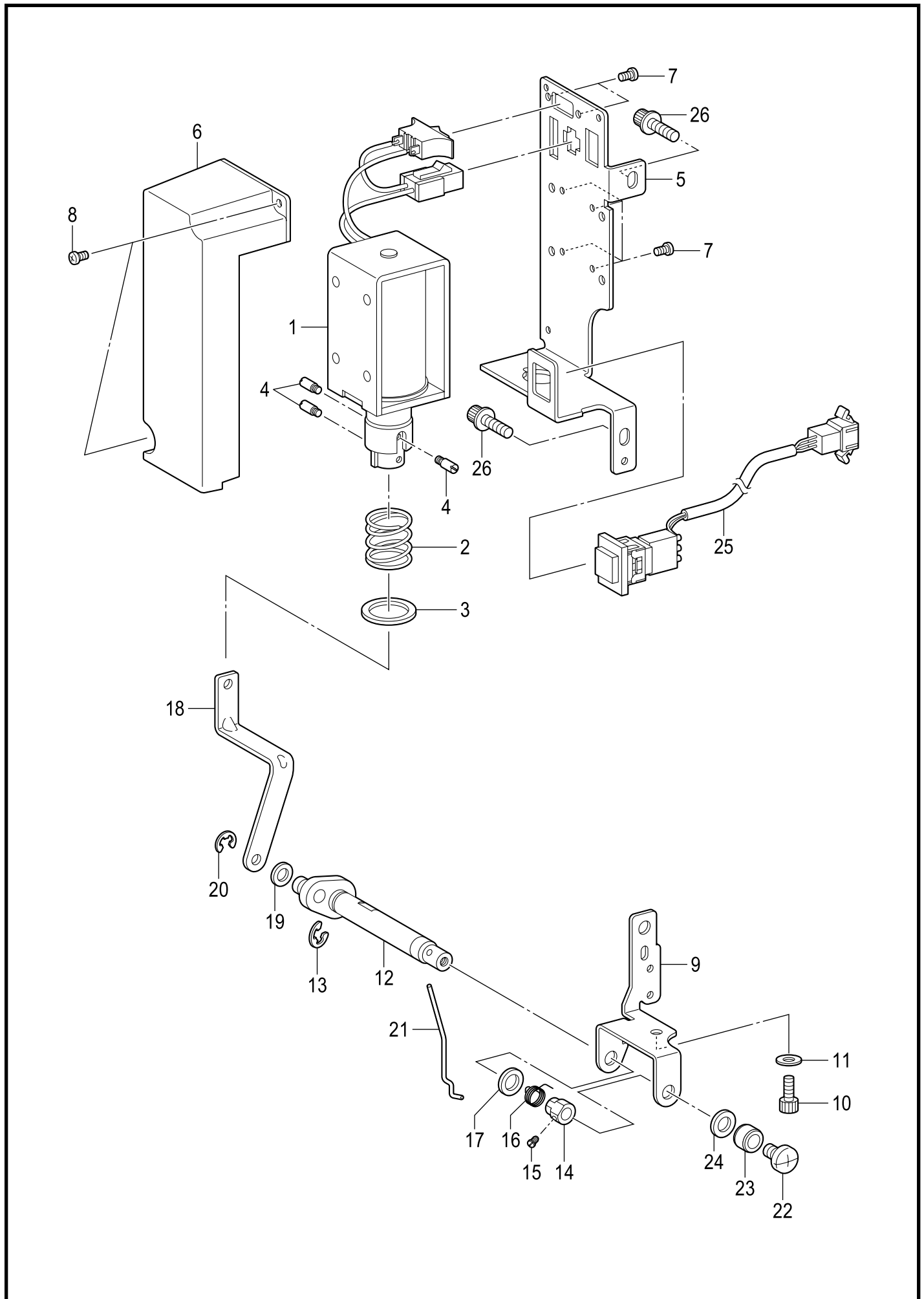

BAS-342G-405

K. 糸払い関係 / Thread wiper mechanism

REF.NO	CODE	Q'TY	品名	NAME OF PARTS	RM
1	SA5208001	1	イトハライソレノイドクミ	THREAD WIPER SOLENOID ASSY	
2	S41206001	1	イトハライバネ	THREAD WIPER SPRING	
3	S41205001	1	ヒラザガネ	WASHER, PLAIN	
4	S25456001	3	プランジヤピン	PLUNGER PIN	
5	SA5217001	1	イトハライSOLTリツケイタ	T-WIPER SOLENOID SETTING PLATE	
6	SA4806001	1	ソレノイドカバー	SOLENOID COVER	
7	062300616	6	ナベコ3X6	SCREW PAN M3X6	
8	0A4300606	2	+ナベザクミ3X6DA	SCREW PAN (S/P WASHER) M3X6	
9	SA5218001	1	イトハライジクウケイタ	THREAD WIPER SHAFT BRACKET	
10	018400836	1	アナボルト4X8	BOLT SOCKET M4X8	
11	025040236	1	ヒラザガネチュウ4	WASHER PLAIN M 4	
12	SA8057001	1	イトハライクランククミ	THREAD WIPER CRANK ASSY	
13	048040342	1	トメワE4	RETAINING RING E4	
14	S25454001	1	セットカラー	SET SCREW COLLAR	
15	S25279101	1	アタマトメクボミM35-5	SET SCREW (CP) M3.5-5	
16	SA2287001	1	ワイパーバネ	SPRING	
17	149097000	1	シヨウオンシート	SILENT SHEET	
18	SA5219001	1	イトハライロッド	THREAD WIPER ROD	
19	110735001	1	ザガネ	WASHER	
20	048030342	1	トメワE3	RETAINING RING E3	
21	S10470201	1	ワイパー	WIPER	
22	060400516	1	バインド4X5	SCREW BIND M4X5	
23	146288001	1	イトハライジクカラー	THREAD WIPER STUD COLLAR	
24	S03677001	1	ザガネ	WASHER	
25	SA5213001	1	テイシSWクミ	STOP SWITCH ASSY	
26	S55485001	2	アナボルトザクミ5X12	BOLT SOCKET (S/P WASHER) M5X12	

L . 糸緩め関係 / Tension release mechanism

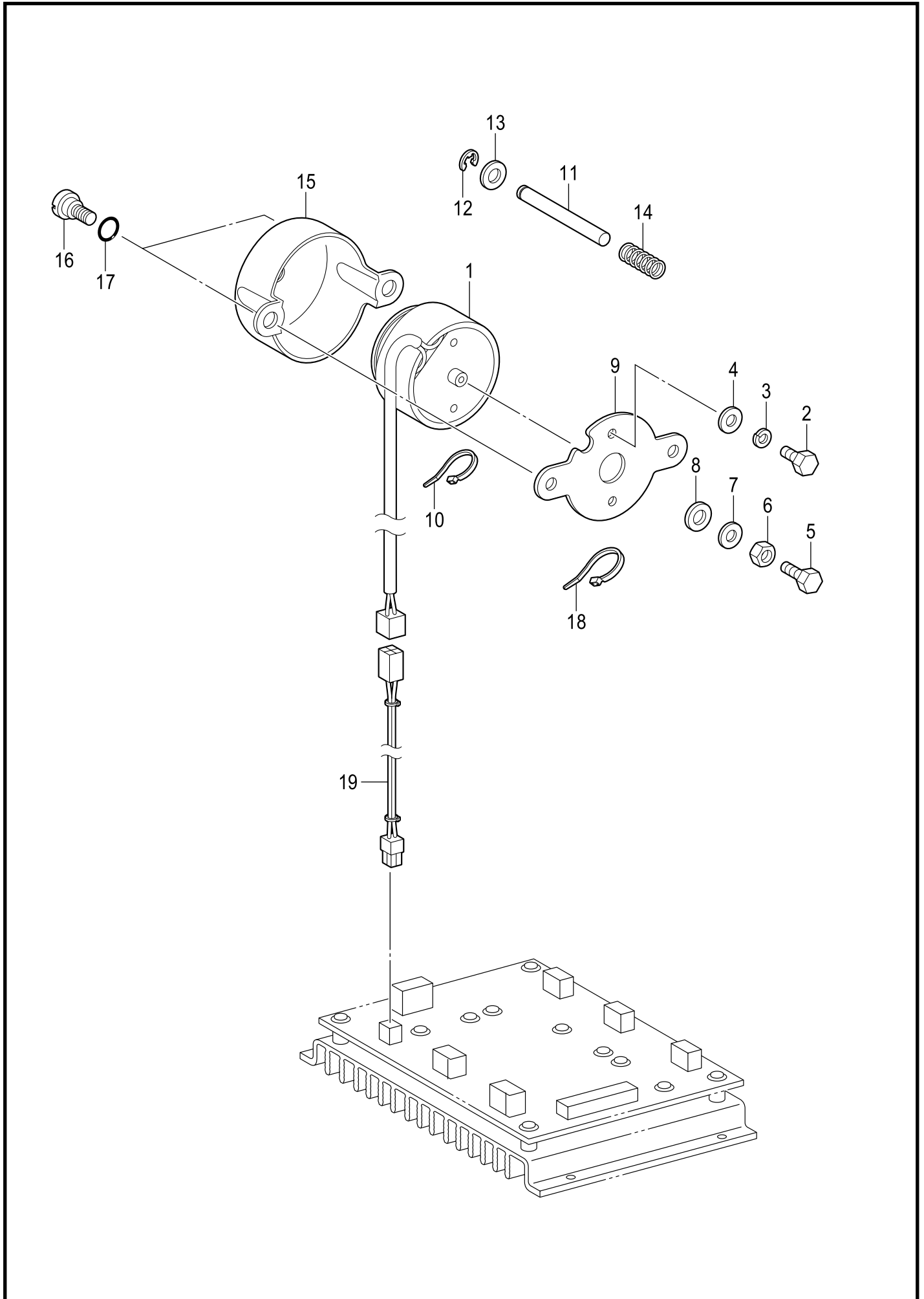

BAS-342G-406

L. 糸緩め関係 / Tension release mechanism

REF.NO	CODE	Q'TY	品名	NAME OF PARTS	RM
1	SA4855001	1	イトユルメソレノイドHV	TENSION RELEASE SOLENOID HV	
2	017400802	2	ボルト4X8	BOLT M4X8	
3	028040246	2	バネザガネ2-4	WASHER SPRING 2-4	
4	026040236	2	ヒラザガネミガキ4	WASHER PLAIN M 4	
5	017401415	1	ボルト4X14	BOLT M4X14	
6	021400306	1	3シュナット4	NUT 3 M4	
7	102707002	1	ザガネ	WASHER	
8	154599000	1	ソレノイドクッション	SOLENOID CUSHION	
9	SA6389001	1	ソレノイドトリツケイタ	SETTING PLATE SOLENOID	
10	S04159000	1	バンド1M	BAND 1M	
11	SA3347001	1	イトユルメボウ	TENSION RELEASE BAR	
12	048040342	1	トメワE4	RETAINING RING E4	
13	025050236	1	ヒラザガネチュウ5	WASHER PLAIN M 5	
14	SA3348001	1	コイルバネ	SPRING, COMPRESSION	
15	SA3349001	1	ソレノイドカバー	SOLENOID COVER	
16	SA3306001	2	ダンネジ7-3	SHOULDER SCREW, 7-3	
17	081007070	2	OリングP7	O RING P7	
18	S04159000	1	バンド1M	BAND 1M	
19	SA8529001	1	イトユルメEXTハーネス	T-RELEASE EXTENSION HRANESS	

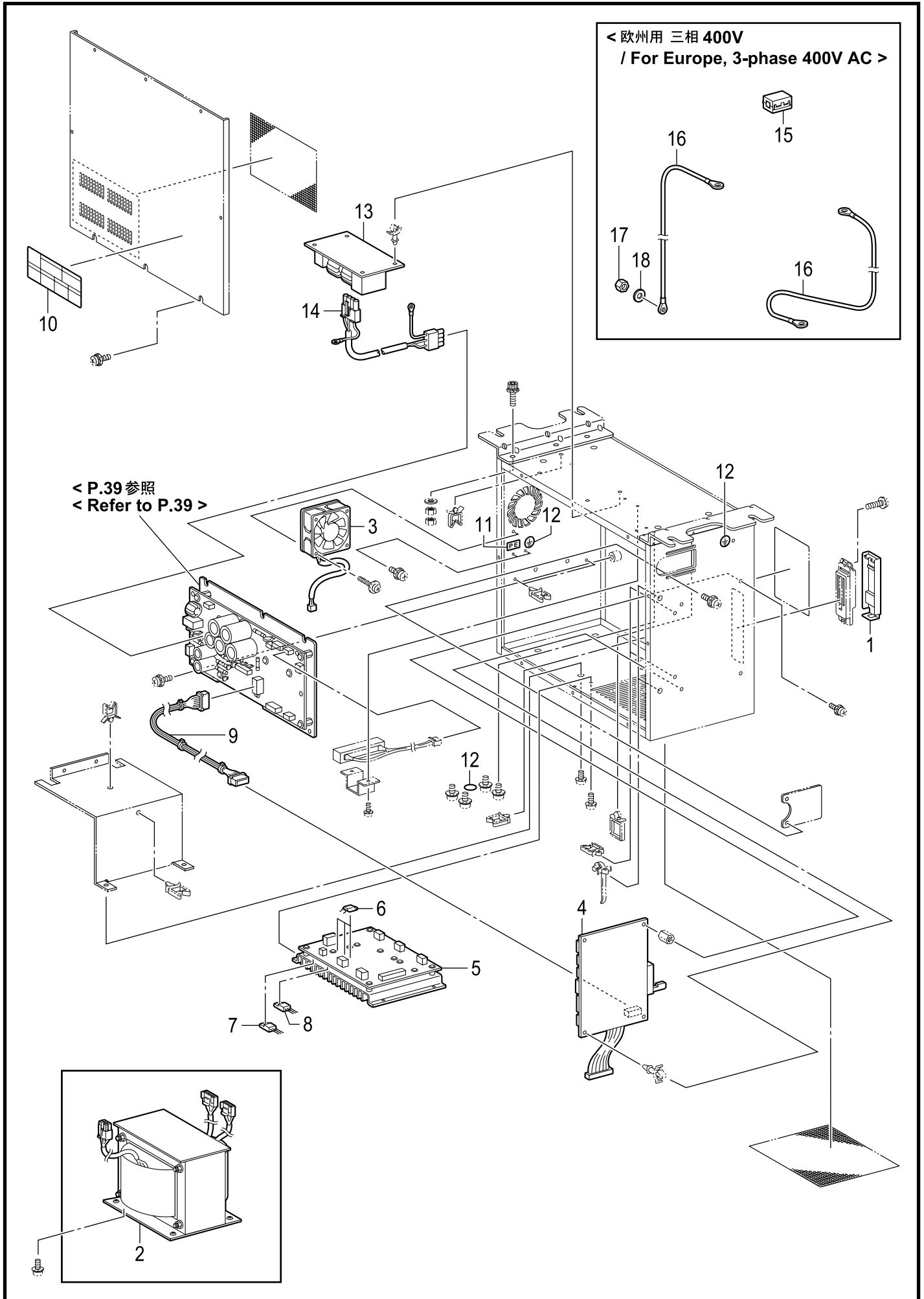

M1. コントロールボックス関係 / Control box mechanism

REF.NO	CODE	Q'TY	品名	NAME OF PARTS	RM
1	SA6364001	1	CFキャップクミ	CF CAP ASSY	
2	SA3808101	1	トランス342G	TRANSFORMER 342G	
3	SA3797001	1	DCファンモータクミ	DC-FAN MOTOR ASSY	
4	SA8376001	1	メインキバン342Gクミ	PCB ASSY MAIN 342G	
5	SA8378001	1	PMDキバン342Gクミ	PCB ASSY PMD 342G	
6	SA3744001	3	FET FS10ASJ-2	TRANSISTOR, FET: FS10ASJ-2	
7	SA3722001	1	MOSFET FX20KMJ2	TRANSISTOR, FET: FX20KMJ-2	
8	S49484000	1	MOSFETFS10KMJ-2	TRANSISTOR, FET: FS10KMJ-2	
9	SA3806001	1	MAINデンゲンハーネス	HARNESS, MAIN POWER SUPPLY	
10	J04115001	1	ラベル感電6ヶ国	LABEL, ELEC. SHOCK 6 LANG	
11	S37059001	1	PE マーク	LABEL, PE	
12	S37060001	3	アースマーク	LABEL, GROUNDING	
13	SA3581001	1	フィルタキバンクミ	PCB ASSY, NF	
14	SA3796001	1	NF OUTコード	HARNESS, NF OUT	
			<欧州用 三相 400V>	<For Europe, 3-phase 400V AC.>	
15	S52163000	3	コアNF-130	CORE, NF-130	
16	SA3788001	2	アースセンEC	GROUND WIRE EC	
17	021400106	1	1シュナット4	NUT 1 M4	
18	025040236	2	ヒラザガネチュウ4	WASHER PLAIN M 4	

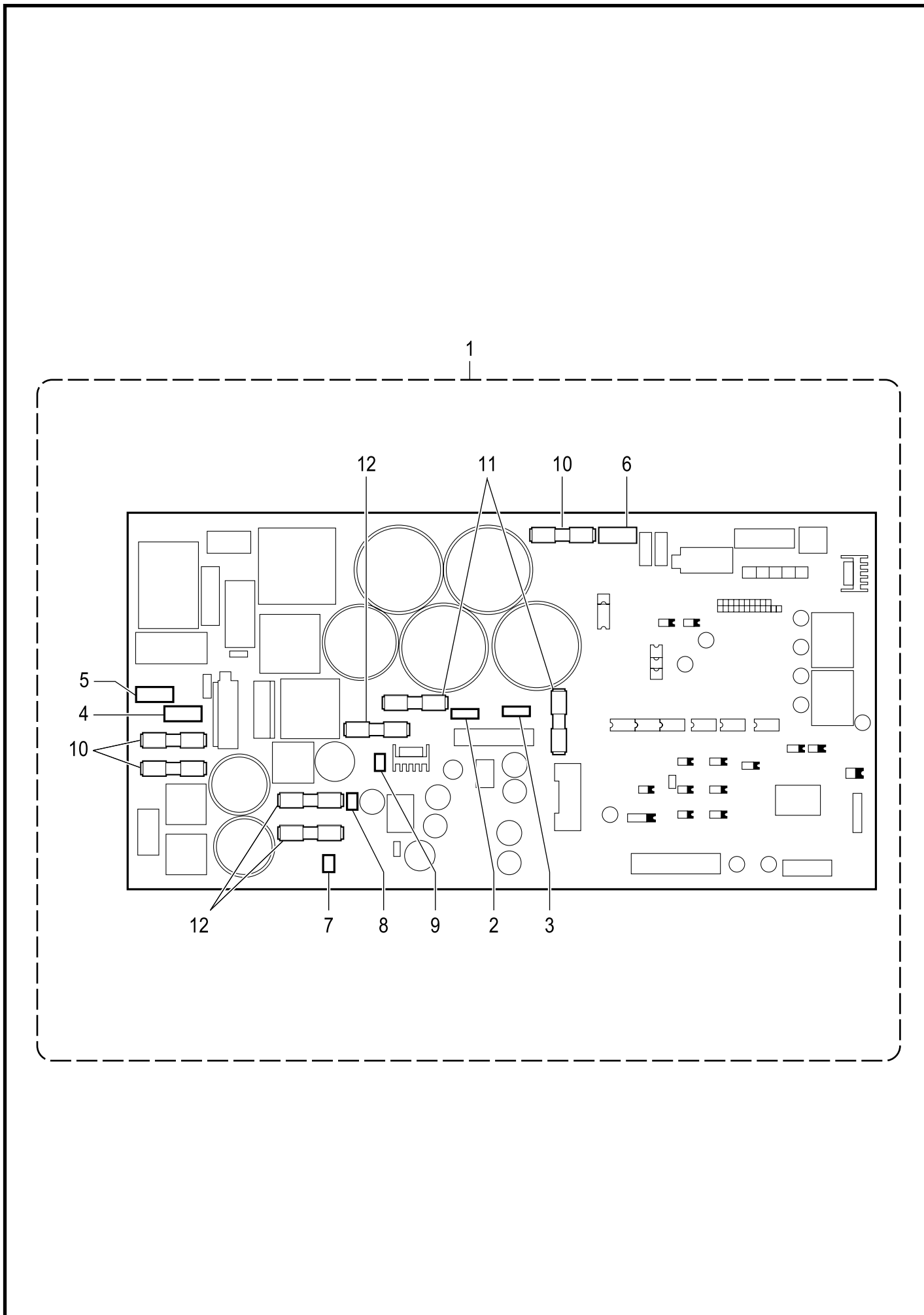

M2. コントロールボックス関係 (電源モータ基板) / Control box mechanism (Power supply motor PCB)

REF.NO	CODE	Q'TY	品名	NAME OF PARTS	RM
1	SA8383001	1	デンゲンモータキバンクミC	PCB ASSY POWER SUPPLY MOTOR C	
2	SA3765001	1	バリスタTNR10V101K	VARISTOR: V10D101	
3	SA8384001	1	バリスタTND10V471K	VARISTOR: V10D471	
4	SA3767001	1	バリスタTNR14V511K	VARISTOR: V14D511	
5	SA3762001	1	バリスタTNR14V911K	VARISTOR: V14D911	
6	SA3768001	1	バリスタTNR14V561K	VARISTOR: V14D561	
7	SA3769001	1	バリスタTNR5V121K	VARISTOR: V5D121	
8	SA3770001	1	バリスタTNR5V330K	VARISTOR: V5D330	
9	SA3771001	1	バリスタTNR5V820K	VARISTOR: V5D820	
10	SA3794001	3	FGMB 250V-15A	G FUSE S 15A	
11	SA3795001	2	FGMB 250V-6A	G FUSE S 6A	
12	SA7794001	3	GFUSE 3A	G FUSE S 3A	

< 日本用 三相 200V / For Japan, 3-phase 200V AC.>

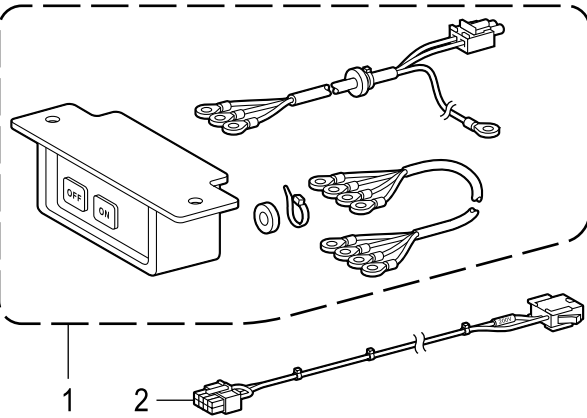

< 中国用 三相 380V / For China, 3-phase 380V AC. >

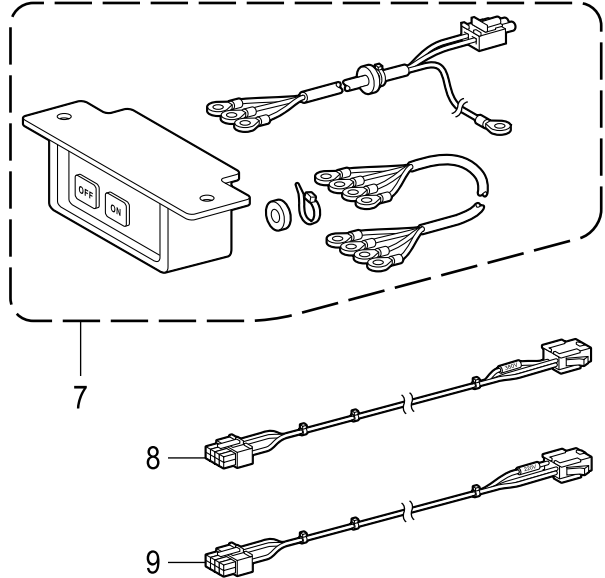

< USA 用 三相 220V / For USA, 3-phase 220V AC. >

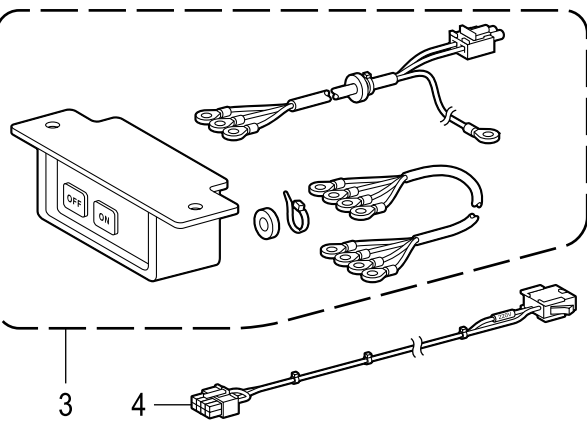

< アジア・中国用 単相 220V
/ For Asia and China, 1-phase 220V AC. >

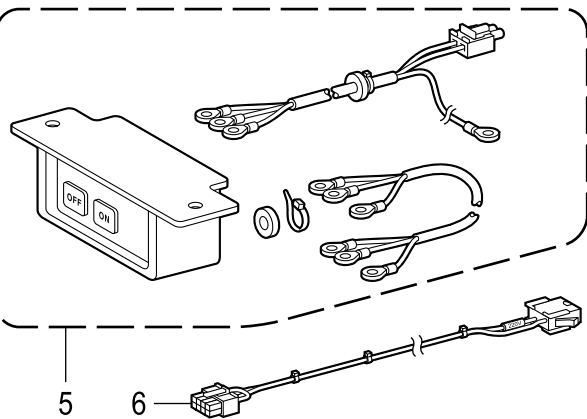

< 欧州用 三相 400V / For Europe, 3-phase 400V AC. >

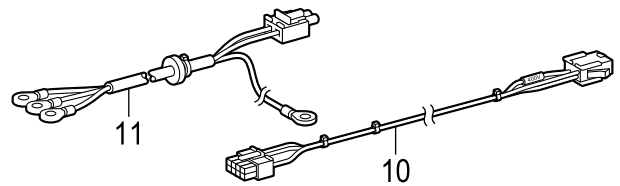

N. スイッチ関係 / Power switch mechanism

REF.NO	CODE	Q'TY	品名	NAME OF PARTS	RM
1	SA8824001	1	<日本用 三相 200V> デンSWクミ3P-JPN NF	<For Japan, 3-phase 200V AC.> POWER SUPPLY SW ASSY 3P-JP NF	
2	SA8387001	1	Vキリカエハーネス200V#2	VOLTAGE SELECT HARNESS 200V #2	
3	SA8825001	1	<USA用 三相 220V> デンSWクミ3P-L NF	<For USA, 3-phase 220V AC.> POWER SUPPLY SW ASSY 3P-L NF	
4	SA3789101	1	VキリカエハーネスH220V	VOLTAGE SELECT HARNESS H220V	
5	SA8827001	1	<アジア・中国用 単相 220V> デンSWクミ1P	<For Asia and China, 1-phase 220V AC.> POWER SUPPLY SW ASSY 1P NF	
6	SA3789101	1	VキリカエハーネスH220V	VOLTAGE SELECT HARNESS H220V	
7	SA8826001	1	<中国用 三相 380V> デンSWクミ3P-H	<For China, 3-phase 380V AC.> POWER SUPPLY SW ASSY 3P-H NF	
8	SA3827001	1	Vキリカエハーネス380V	VOLTAGE SELECT HARNESS 380V	
9	SA3789101	1	VキリカエハーネスH220V	VOLTAGE SELECT HARNESS H220V	
10	SA3828001	1	<欧州用 三相 400V> Vキリカエハーネス400V	<For Europe, 3-phase 400V AC.> VOLTAGE SELECT HARNESS 400V	
11	SA3838001	1	ACINコードECクミ	HARNESS ASSY AC IN EC	

P . 空圧関係 / Air pressure mechanism

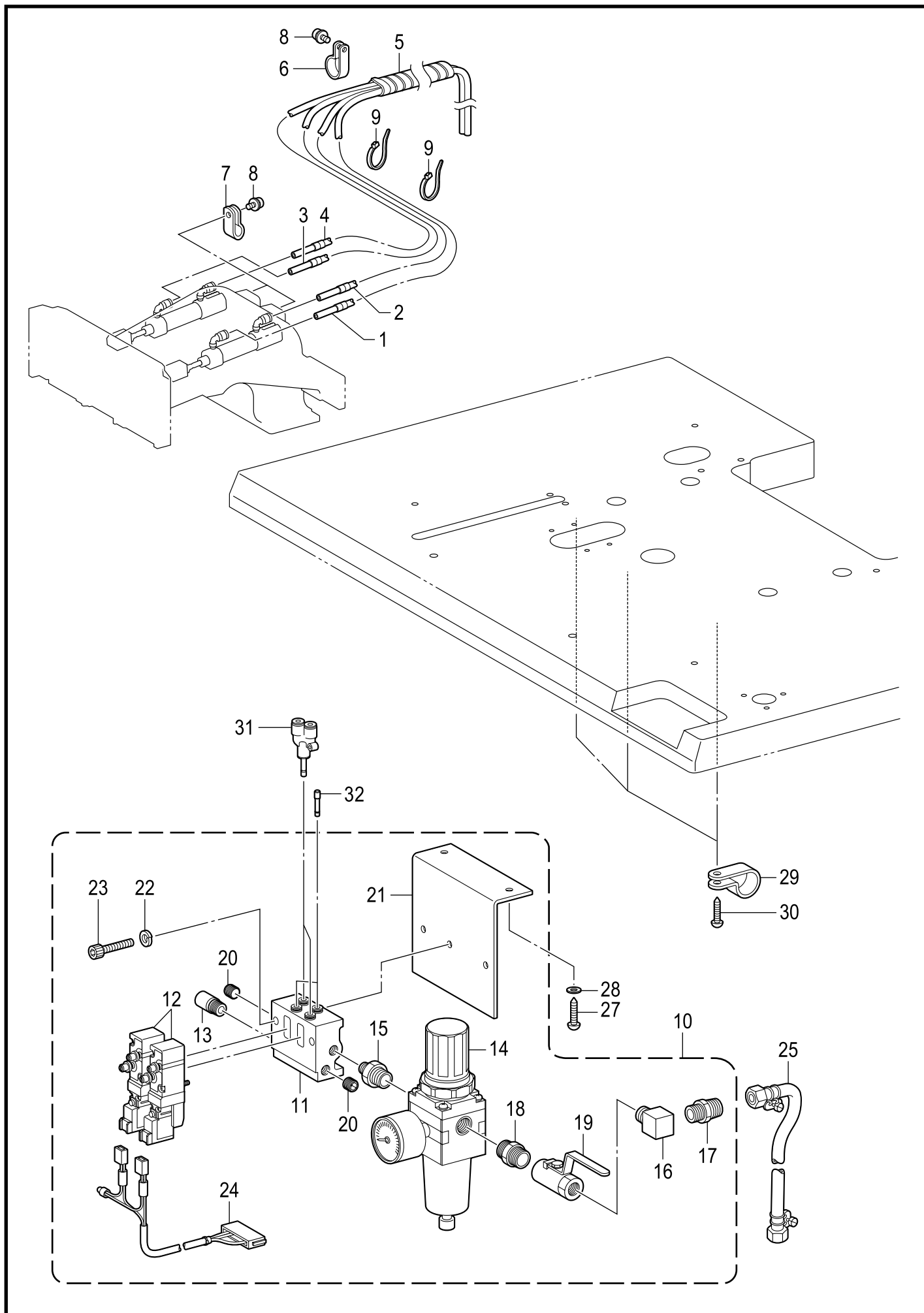

BAS-342G-514

P. 空圧関係 / Air pressure mechanism

REF.NO	CODE	Q'TY	品名	NAME OF PARTS	RM
1	SA8659001	1	エアチューブR	AIR TUBE R	
2	SA8659002	1	エアチューブR	AIR TUBE R	
3	SA8660001	1	エアチューブL	AIR TUBE L	
4	SA8660002	1	エアチューブL	AIR TUBE L	
5	SA8661001	2	スパイラル650S	SPIRAL 650S	
6	525664000	1	コードホルダ#6	CORD HOLDER #6	
7	149547000	2	コードオサエ	CORD HOLDER 4N	
8	0A5401005	3	+ナベザクミ4X10DB	SCREW PAN (S/P WASHER) M4X10	
9	228475000	2	ケツソクバンド1.9X80	FASTENING BAND 1.9X80	
10	SA5281101	1	デンジバルブ2Aクミ	SOLENOID VALVE ASSY 2A	
11	SA5289001	1	マニホールド2	MANIFOLD2	
12	S39116100	2	バルブVQZ2151S-5	VALVE VQZ2151S-5	
13	SA5283001	1	サイレンサ AN103-1	SILENCER AN103-1	
14	SA5282001	1	レギュレ-タ AW20-02G	FILTER REGULATOR AW20-02G	
15	S09228000	1	イケイニツプル	NIPPLE 1/4X1/8	
16	153252000	1	PTチ-ズ	PT-JOINT	
17	S04891000	1	チュウカンニツプル1/4	MIDDLE NIPPLE, 1/4	
18	SA5285001	1	チュウカンニツプル1/4	MIDDLE NIPPLE 1/4	
19	SA6573001	1	ボールバルブV03 1/4	BALL VALVE V03 1/4	
20	153274001	2	1/8トメセン	CAP, 1/8	
21	SA5286101	1	バルブトリツケイタ	SETTING PLATE VALVE	
22	028050246	2	バネザガネ2-5	WASHER SPRING 2-5	
23	018503036	2	アナボルト5X30	BOLT SOCKET M5X30	
24	SA5191001	1	バルブハーネス2レンクミ	VALVE HARNESS X2 ASSY	
25	149796001	1	ゴムホ-スカナグツキ	AIR HOSE, W/CONNECTOR	
27	032422003	2	+2マルモク41X20	WOOD SCREW, ROUND 2 M4.1X20	
28	148847001	2	ザガネ	WASHER PLAIN 4.76	
29	554482000	3	コードホルダ#12	CORD HOLDER #12	
30	032422003	3	+2マルモク41X20	WOOD SCREW, ROUND 2 M4.1X20	
31	S53978000	2	ブランチュニオンY	BRANCH, Y	
32	S53983000	2	プラグ4	PLUG, 4	

Q . 電装品関係 / Power supply equipment mechanism

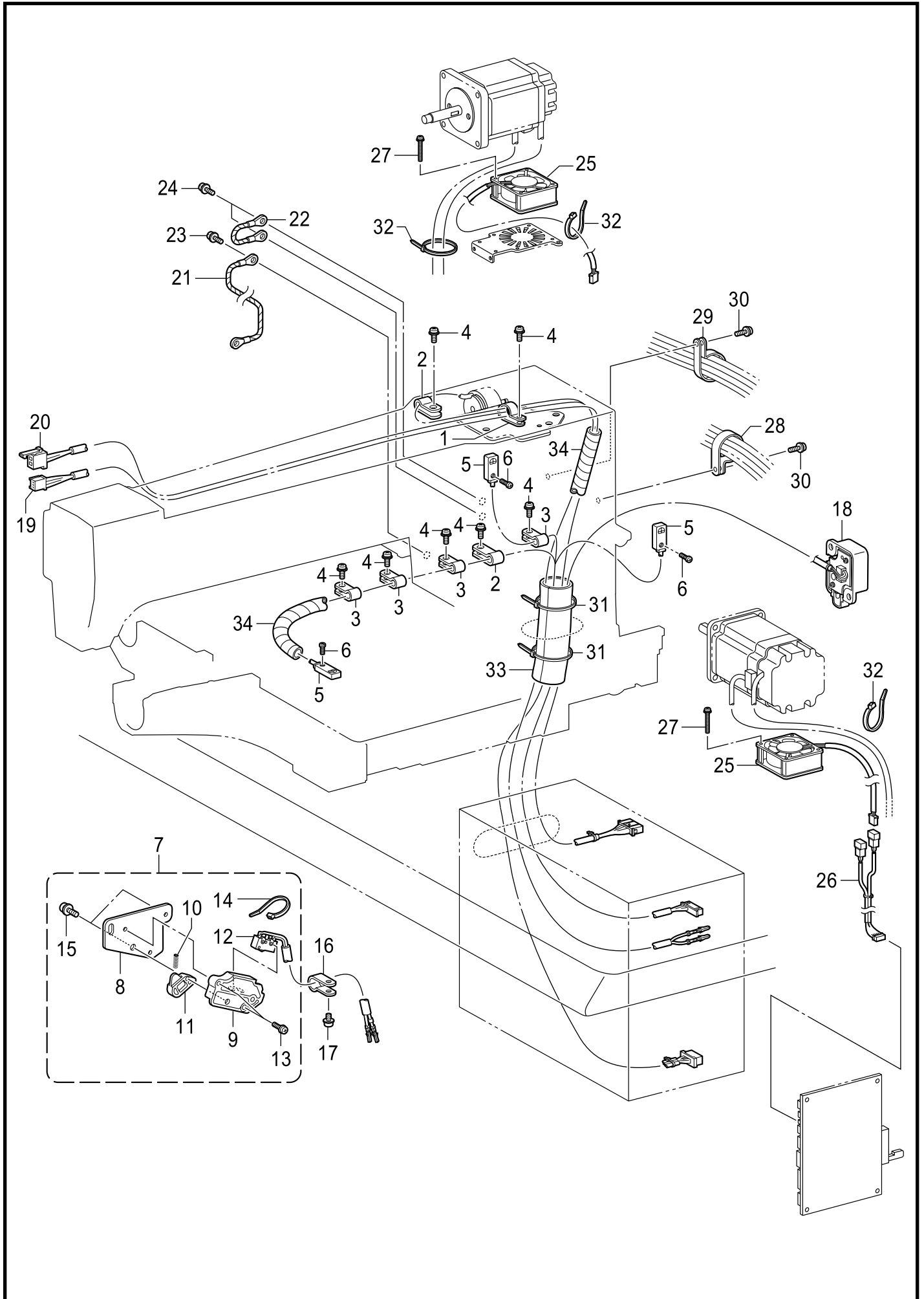

Q. 電装品関係 / Power supply equipment mechanism

REF.NO	CODE	Q'TY	品名	NAME OF PARTS	RM
1	525567000	1	コードホルダ#8	CORD HOLDER #8	
2	149547000	2	コードオサエ	CORD HOLDER 4N	
3	625010000	4	ナイロンクランプNK-2N	NYLON CLAMP NK-2N	
4	0A5401006	7	+ナベザクミ4X10DB	SCREW PAN (S/P WASHER) M4X10	
5	SA8521001	1	ゲンテンセンサ342Gクミ	H-POSITION SENSOR 342G ASSY	
6	062300816	3	ナベコ3X8	SCREW PAN M3X8	
7	SA8522001	1	アンゼンSWイタクミ342G	SAFETY SWITCH PLATE ASSY 342G	
8	SA8523001	1	アンゼンSWイタ342G	SAFETY SWITCH PLATE 342G	
9	SA5730101	1	アンゼンスイッチベース	SAFETY SWITCH BASE	
10	SA5731001	1	アンゼンスイッチバネ	SAFETY SWITCH SPRING	
11	SA5732101	1	アンゼンスイッチレバー	SAFETY SWITCH LEVER	
12	SA8524001	1	アンゼンSWクミ	SAFETY SWITCH ASSY	
13	SA7293001	2	ナベザクミM3X12	SCREW PAN (S/P W) M3X12	
14	S04159000	1	バンド1M	BAND 1M	
15	0A5401006	2	+ナベザクミ4X10DB	SCREW PAN (S/P WASHER) M4X10	
16	149547000	1	コードオサエ	CORD HOLDER 4N	
17	0A5401006	1	+ナベザクミ4X10DB	SCREW PAN (S/P WASHER) M4X10	
18	SA9105001	1	トウブケンシユツユニット	HEAD DETECTOR UNIT	
19	SA8527001	1	テイシSWハーネス342G	STOP SWITCH HARNESS 342G	
20	SA8528001	1	イトハライソレノイドハーネス	WIPER SOLENOID HARNESS 342G	
21	SA3486001	1	アースセン350	GROUND WIRE 350	
22	SA5433001	1	アースセン	GROUND WIRE	
23	0A5401006	1	+ナベザクミ4X10DB	SCREW PAN (S/P WASHER) M4X10	
24	0A5401006	2	+ナベザクミ4X10DB	SCREW PAN (S/P WASHER) M4X10	
25	SA8532001	2	DCファンクミ	DC-FAN MOTOR ASSY	
26	SA8533001	1	DCファンハーネス	DC-FAN HARNESS	
27	0A5403006	8	+ナベザクミ4X30DB	SCREW PAN (S/P WASHER) M4X30	
28	554482000	1	コードホルダ#12	CORD HOLDER #12	
29	S00470000	1	コードホルダ#16	CORD HOLDER 16N	
30	0A5401006	2	+ナベザクミ4X10DB	SCREW PAN (S/P WASHER) M4X10	
31	218859001	2	バインダM150	BINDER M150	
32	S04159000	3	バンド1M	BAND 1M	
33	SA8881001	1	クイックチューブ30X400	QUICK TUBE 30X400	
34	SA6366001	1	スパイラル140S	SPIRAL TUBE	

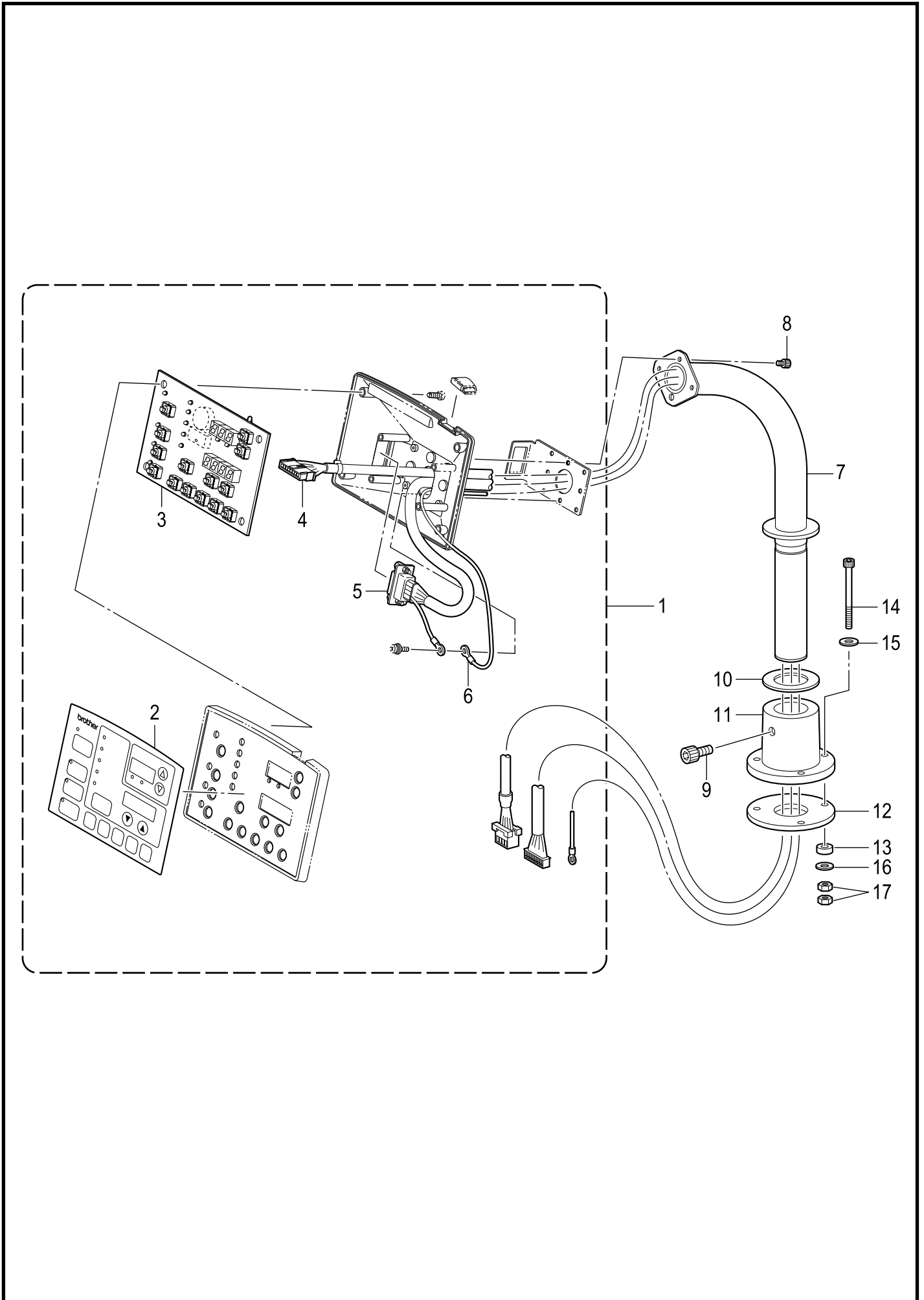

R. 操作パネル関係 / Operation panel mechanism

REF.NO	CODE	Q'TY	品名	NAME OF PARTS	RM
1	SA4834101	1	ソウサパネルクミ	OPERATION PANEL ASSY	
2	SA3831001	1	ソウサパネルシート	PANEL SHEET	
3	SA3833201	1	パネルキバンクミ	PANEL PCB ASSY	
4	SA4563101	1	パネルハーネス	PANEL HARNESS	
5	SA4837101	1	プログラマチューケイハーネス	PROGRAMMER CONNECTING HARNESS	
6	SA4841101	1	アースセン	GROUND WIRE	
7	SA4836001	1	ソウサパネルシチュウ	OPERATION PANEL STAND	
8	018400636	3	アナボルト4X6	BOLT SOCKET M4X6	
9	018081636	1	アナボルト8X16	BOLT SOCKET M8X16	
10	S10408000	1	ゴムシート	RUBBER SHEET	
11	S43236009	1	ソウサパネルドダイ	OPERATION PANEL BASE	
12	S43674000	1	クツシヨンA	CUSHION, A	
13	S43675000	3	クツシヨンB	CUSHION, B	
14	SA8664001	3	アナボルト5X75	BOLT SOCKET M5X75	
15	025050236	3	ヒラザガネチュウ5	WASHER PLAIN M 5	
16	025050336	3	ヒラザガネダイ5	WASHER PLAIN L 5	
17	021500106	6	1シュナツト5	NUT 1 M5	

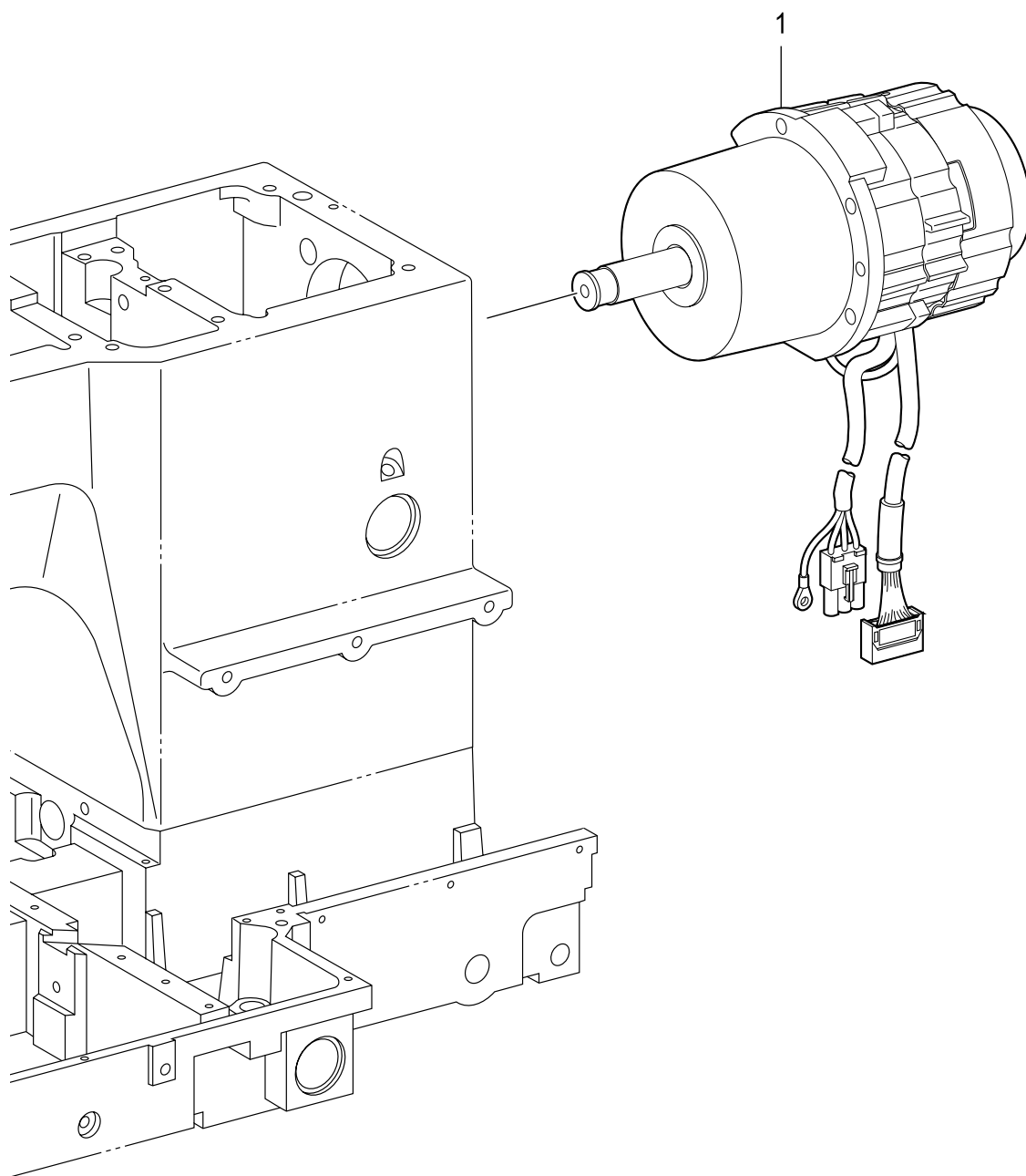

S. モータ関係 / Motor mechanism

REF.NO	CODE	Q'TY	品名	NAME OF PARTS	RM
1	J80991001	1	モータクミCDD-430D	MOTOR ASSY CDD-430D	

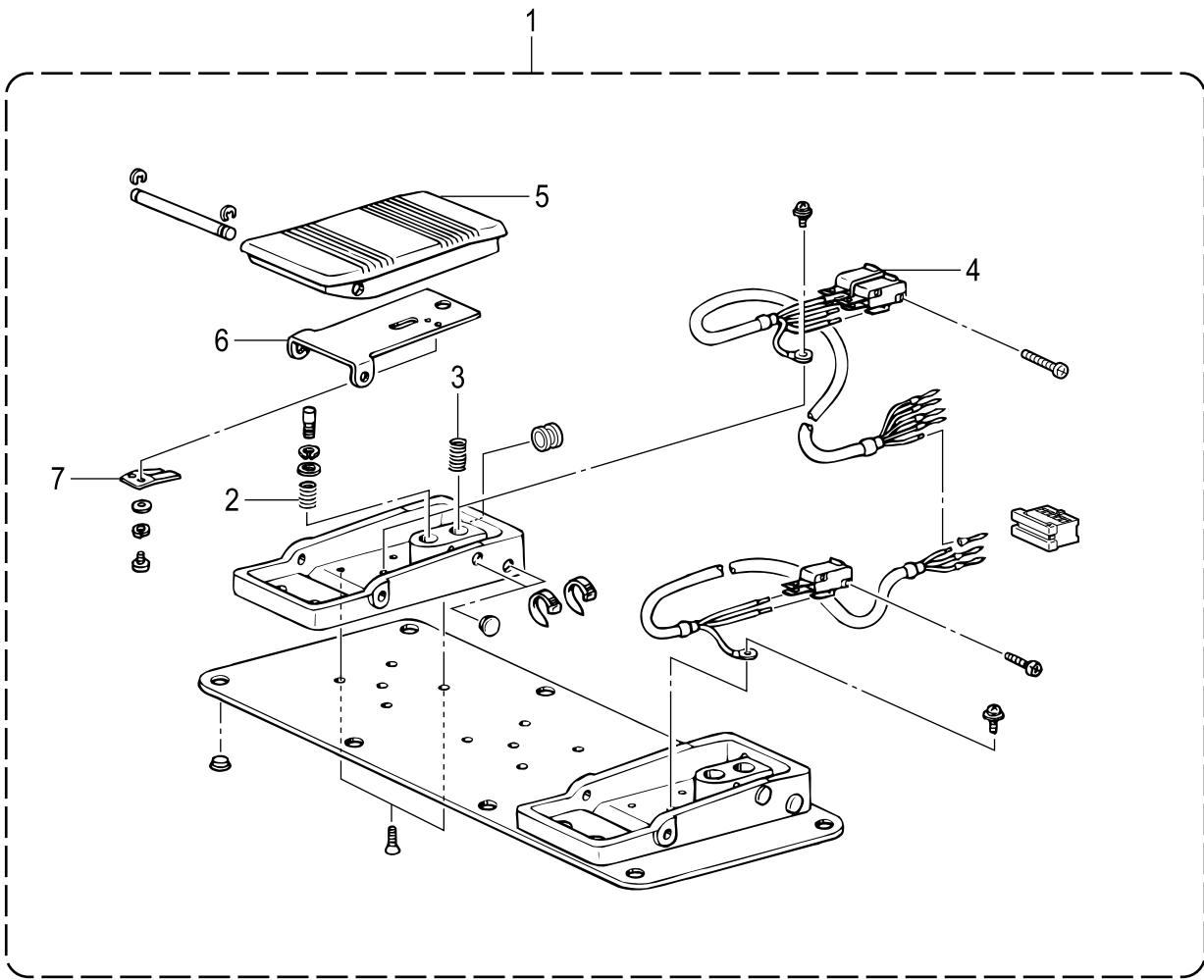

T. 踏板関係 / Foot switch pedal mechanism

REF.NO	CODE	Q'TY	品名	NAME OF PARTS	RM
1	SA6038001	1	2レンフットSWクミ	2-PEDAL FOOT SWITCH, SW ASSY	
2	S38168001	1	アツシユクバネ	SPRING, COMPRESSION 10X30	
3	S38170001	2	フットペダルバネ	FOOT PEDAL SPRING	
4	S36260000	3	スイッチVXピンボタン	PIN BUTTON MICRO SWITCH, VX	
5	S38174000	2	フットペダル	FOOT PEDAL	
6	S38175001	2	ペダルホゴイタ	PROTECTION PLATE, PEDAL	
7	S38176101	2	スイッチオセエバネ	SPRING, PLATE	

U . 動力台関係 / Power table

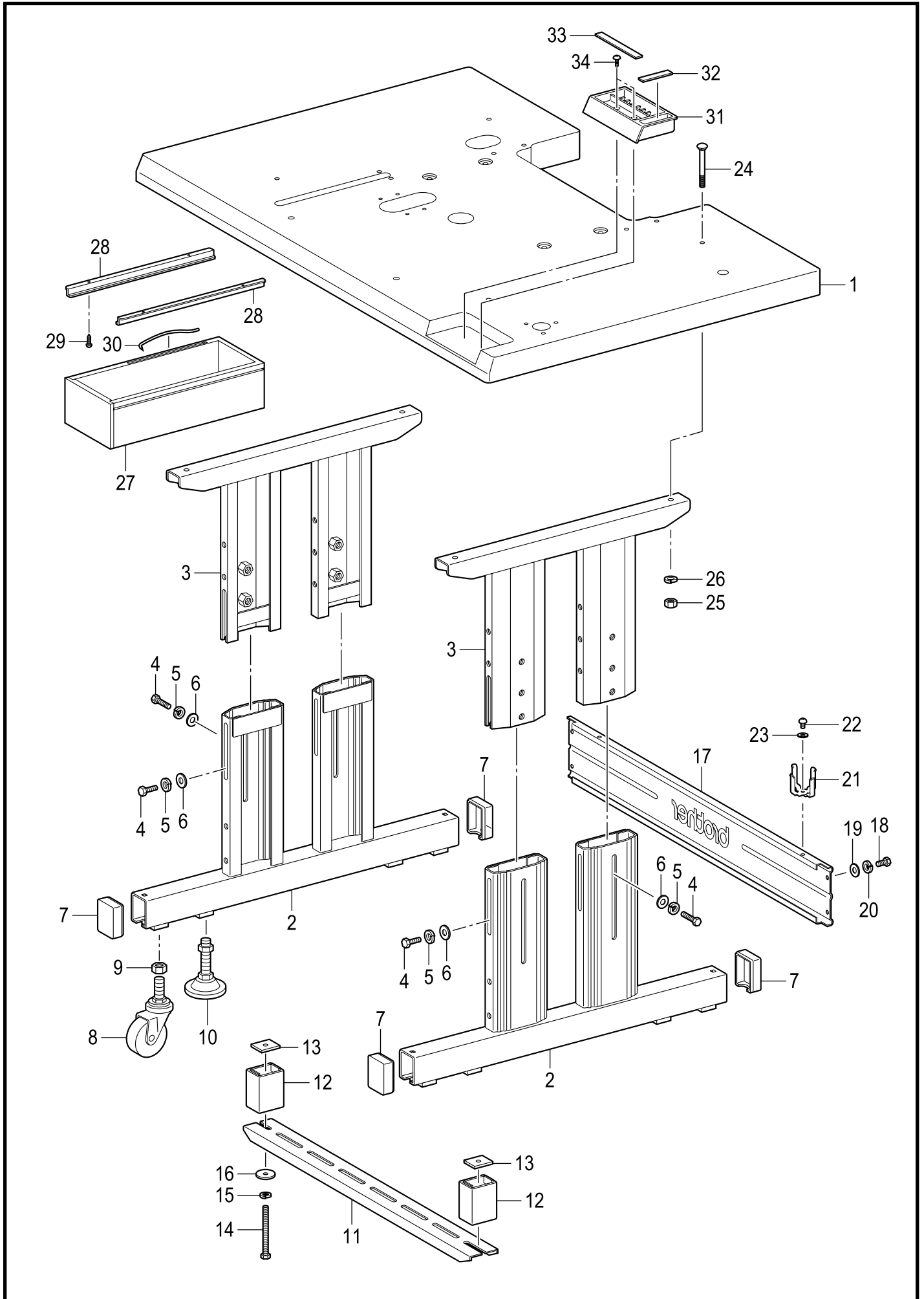

U. 動力台関係 / Power table

REF.NO	CODE	Q'TY	品名	NAME OF PARTS	RM
1	SA8692001	1	テーブル342G	TABLE 342G	
2	SA8248001	2	ソトアシ	OUTER STAND	
3	SA8249001	2	テーブルササエ	TABLE SUPPORT	
4	017081606	12	ボルト8X16	BOLT M8X16	
5	028080246	12	バネザガネ2-8	WASHER SPRING 2-8	
6	S09312001	12	ヒラザガネダイ8	WASHER PLAIN L 8	
7	S10661109	4	ソトアシフタゴム	OUTER STAND CAP RUBBER	
8	152393200	4	キヤスター	CASTER	
9	021160303	4	3シュナツト16	NUT, 3 M16	
10	SA8250001	4	アジャスタ16	ADJUSTER 16	
11	SA8251001	1	フミタササエダイ	TREADLE SUPPORT BASE	
12	S09317109	2	スペーサー	SPACER	
13	S09225001	2	4カクナツト	NUT SQUARE	
14	017080006	2	ボルト8X100	BOLT M8X100	
15	028080246	2	バネザガネ2-8	WASHER SPRING 2-8	
16	S09226001	2	フミタササエザガネ	TREADLE SUPPORT WASHER	
17	S11531009	1	ハリ	BEAM	
18	017081606	4	ボルト8X16	BOLT M8X16	
19	025080236	4	ヒラザガネチュウ8	WASHER PLAIN M 8	
20	028080246	4	バネザガネ2-8	WASHER SPRING 2-8	
21	133172003	1	アブラサシダイ	OILER BASE	
22	037521016	1	2ナベタツピン5X10	TAPPING SCREW PAN 2 M5X10	
23	025050236	1	ヒラザガネチュウ5	WASHER PLAIN M 5	
24	222372001	4	カクネボルト8X70	BOLT, SQUARE M8X70	
25	021080106	4	1シュナツト8	NUT 1 M8	
26	028080246	4	バネザガネ2-8	WASHER SPRING 2-8	
27	119702004	1	ヨコヒキダシ	SIDE DRAWER	
28	101121100	2	ヨコヒキダシササエ	SUPPORTER SIDE DRAWER	
29	032361306	4	+2マルモク35X13	WOOD SCREW ROUND 2 M3.5X13	
30	101073001	1	ヒキダシコテイバネ	SPRING	
31	S15158009	1	コモノケース	ACCESSORY CASE	
32	S02740000	1	フェルト	FELT	
33	S02739000	1	ゴムジシヤクテープ	RUBBER MAGNET TAPE	
34	039411215	2	1トラスタツピン4X12	TAPPING SCREW TRUSS 1 M4X12	

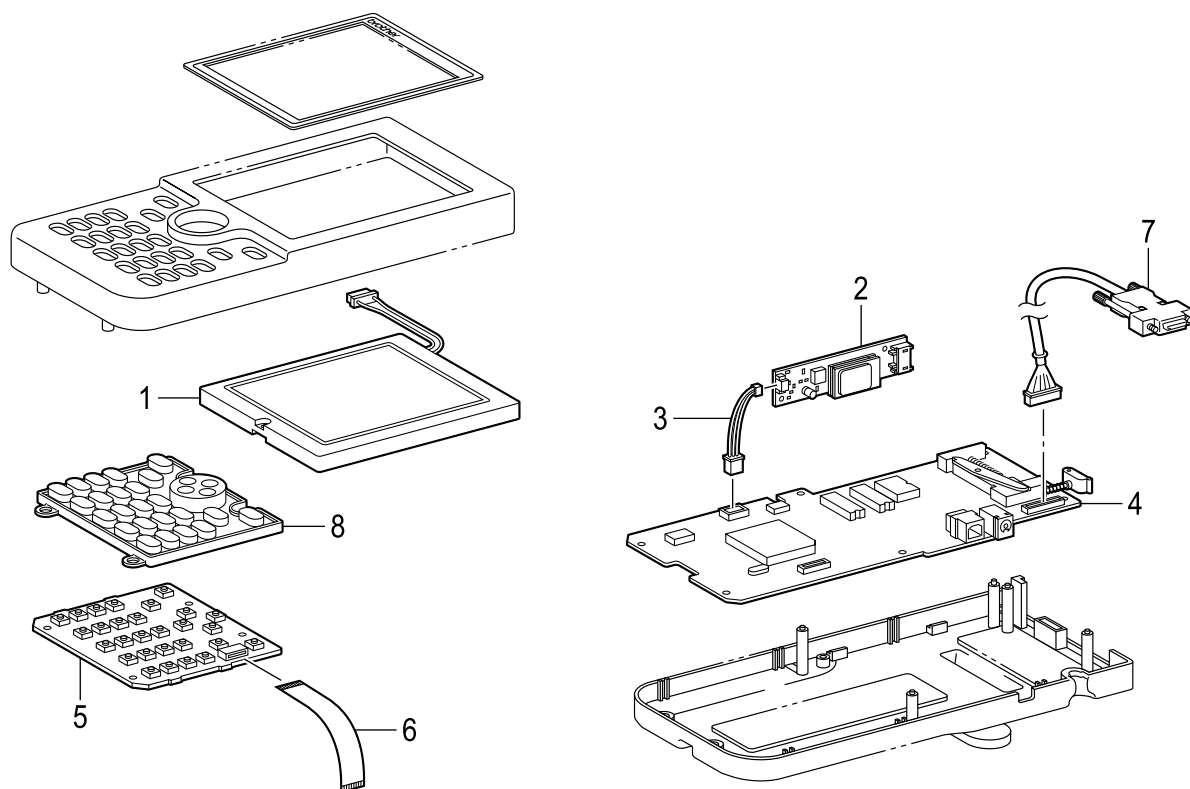

V. プログラマー関係 / Programmer

REF.NO	CODE	Q'TY	品名	NAME OF PARTS	RM
1	SA5164001	1	LCDモジュール	LCD MODULE	
2	SA5165001	1	LCDインバーター	LCD INVERTER	
3	SA5166001	1	インバーターハーネス	INVERTER HARNESS	
4	SA5170001	1	プログラマキバンクミ	PROGRAMMER PCB ASSY	
5	SA5172001	1	スイッチキバンクミ	SWITCH PCB ASSY	
6	XD1115051	2	FFCSML2CD-20	FFC: SML2CD-20X70	
7	SA5167001	1	プログラマハーネス	PROGRAMMER HARNESS	
8	SA4574001	1	キーボード	KEYBOARD	

W1 . 付属装置関係(オプション部品) / Attachment set (Option parts)

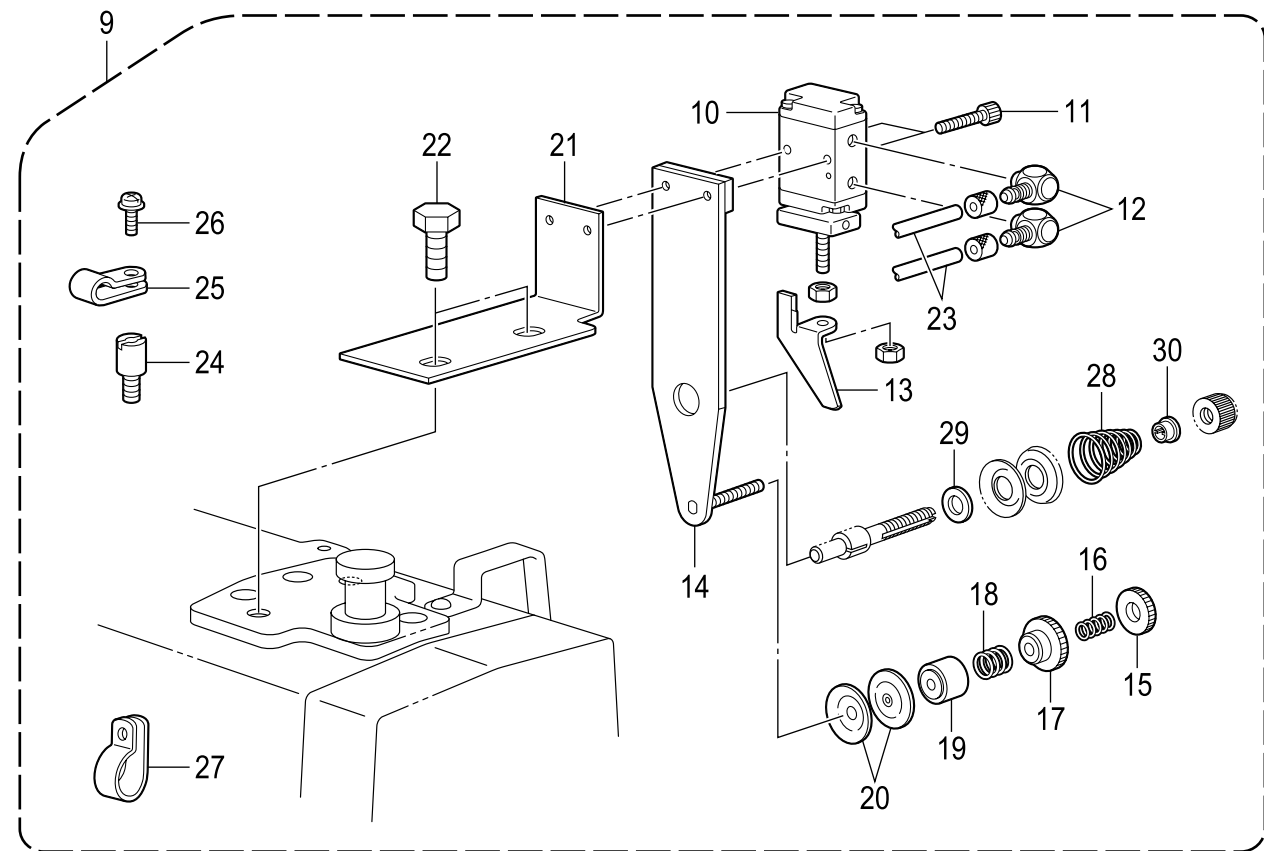
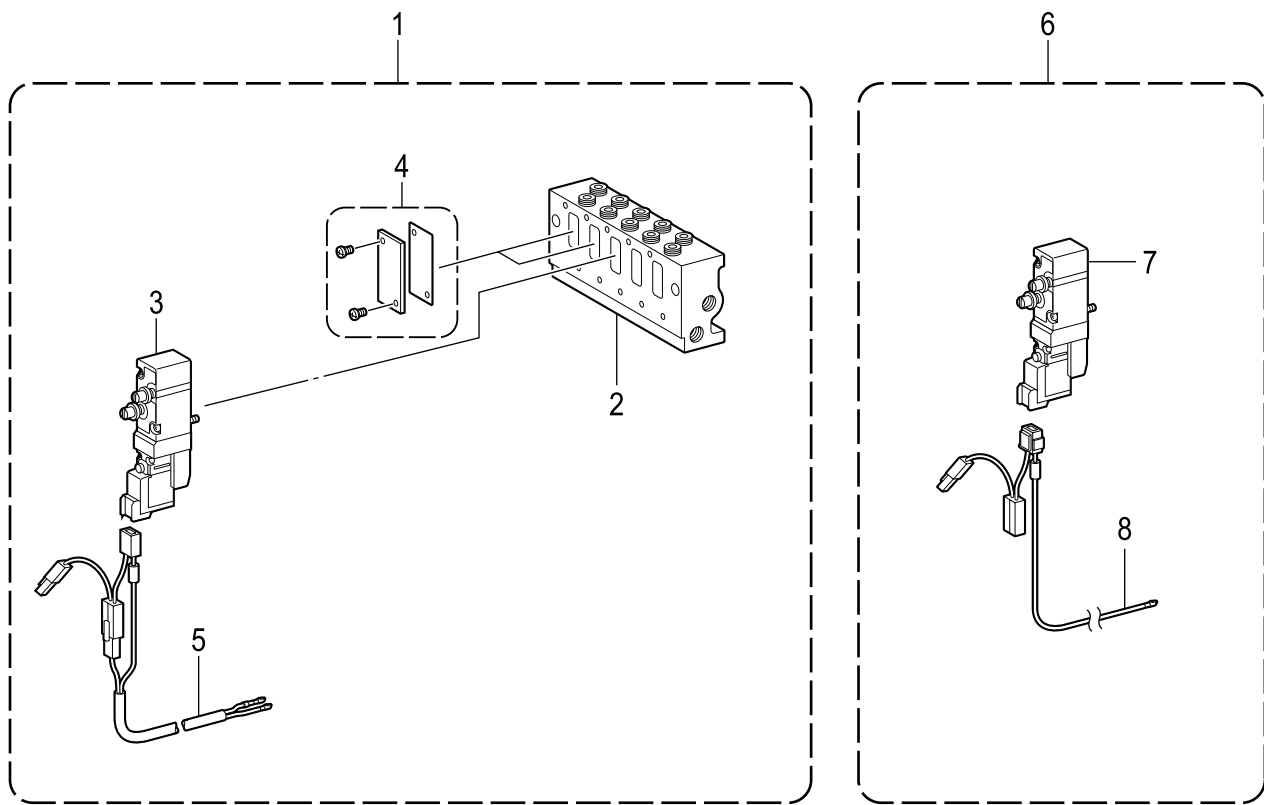

W1. 付属装置関係 (オプション部品) / Attachment set (Option parts)

REF.NO	CODE	Q'TY	品名	NAME OF PARTS	RM
			<欧州向用以外>	<Except for Europe>	
1	SA7500001	1	OPマニホールド5セット	OPTION MANIFOLD 5 SET	
2	SA5290001	1	マニホールド5	MANIFOLD 5	
3	S39116100	1	バルブVQZ2151S-5	VALVE, VQZ2151S-5	
4	S53982000	2	ブランキングプレートクミ	BLANKING PLATE ASSY	
5	SA7166101	1	バルブハーネスX1クミ	VALVE HARNESS ASSY X1	
			<欧州向用>	<For Europe only>	
1	SA75000E1	1	OPマニホールド5セット	OPTION MANIFOLD 5 SET	
2	SA75390E1	1	マニホールド5 WEEE	MANIFOLD 5WEEE	
3	S39116100	1	バルブVQZ2151S-5	VALVE, VQZ2151S-5	
4	S53982000	2	ブランキングプレートクミ	BLANKING PLATE ASSY	
5	SA7166101	1	バルブハーネスX1クミ	VALVE HARNESS ASSY X1	
			<欧州向用以外>	<Except for Europe>	
6	SA7171001	1	OPツイカバルブクミ	OPTION ADD VALVE ASSY	
7	S39116100	1	バルブVQZ2151S-5	VALVE, VQZ2151S-5	
8	SA7167101	1	ツイカバルブハーネスSG	OP VALVE HARNESS SG	
			<欧州向用>	<For Europe only>	
6	SA71710E1	1	OPツイカバルブクミ	OPTION ADD VALVE ASSY	
7	SA74521E0	1	バルブVQZ2151S	VALVE, VQZ2151SWEEE	
8	SA7167101	1	ツイカバルブハーネスSG	OP VALVE HARNESS SG	
9	SA7197001	1	2ダンテンションソウチ	2-STEP THREAD TENSION DEVICE	
10	S34706000	1	エアシリンダ10X10	AIR CYLINDER, 10X10	
11	018302036	2	アナボルト3X20	BOLT SOCKET M3X20	
12	S12150000	2	ホースエルボM-5HL-4	TUBE ELBOW, M-5HL-4	
13	S34533001	1	サラワリツメ	COUNTERSINK CLAW	
14	S34534101	1	サブテンションダイクミ	SUB TENSION BRACKET ASSY	
15	155510001	1	イトチョウシナツト	TENSION NUT	
16	146060000	1	ナットオンバネ	SPRING	
17	146059001	1	プレテンションナツト	PRE-TENSION NUT	
18	146058001	1	プレテンションバネ	PRE-TENSION SPRING	
19	146206009	1	イトアンナイサラオサエ	DISC PRESSER, T-GUIDE	
20	144504001	2	イトアンナイサラ	THREAD GUIDE DISC	
21	SA7199001	1	シリンダートリツケイタ	SETTING BRACKET, CYLINDER	
22	017081606	2	ボルト8X16	BOLT M8X16	
23	S15031008	2	エアチューブ	AIR TUBE, 4X2.5	
24	SA7155001	2	スペーサ	SPACER	
25	S00480000	2	コードホルダ#5	CORD HOLDER, 5N	
26	0A5401006	2	+ナベザクミ4X10DB	SCREW PAN (S/P WASHER) M4X10	
27	525907000	1	コードホルダ#9	CORD HOLDER #9	
28	SA3416101	1	イトチョウシバネLL	TENSION SPRING LL	
29	S48140002	1	ザガネ	WASHER	
30	S20681000	1	チヨウシバネウエザガネ	WASHER	

W2 . 付属装置関係(オプション部品) / Attachment set (Option parts)

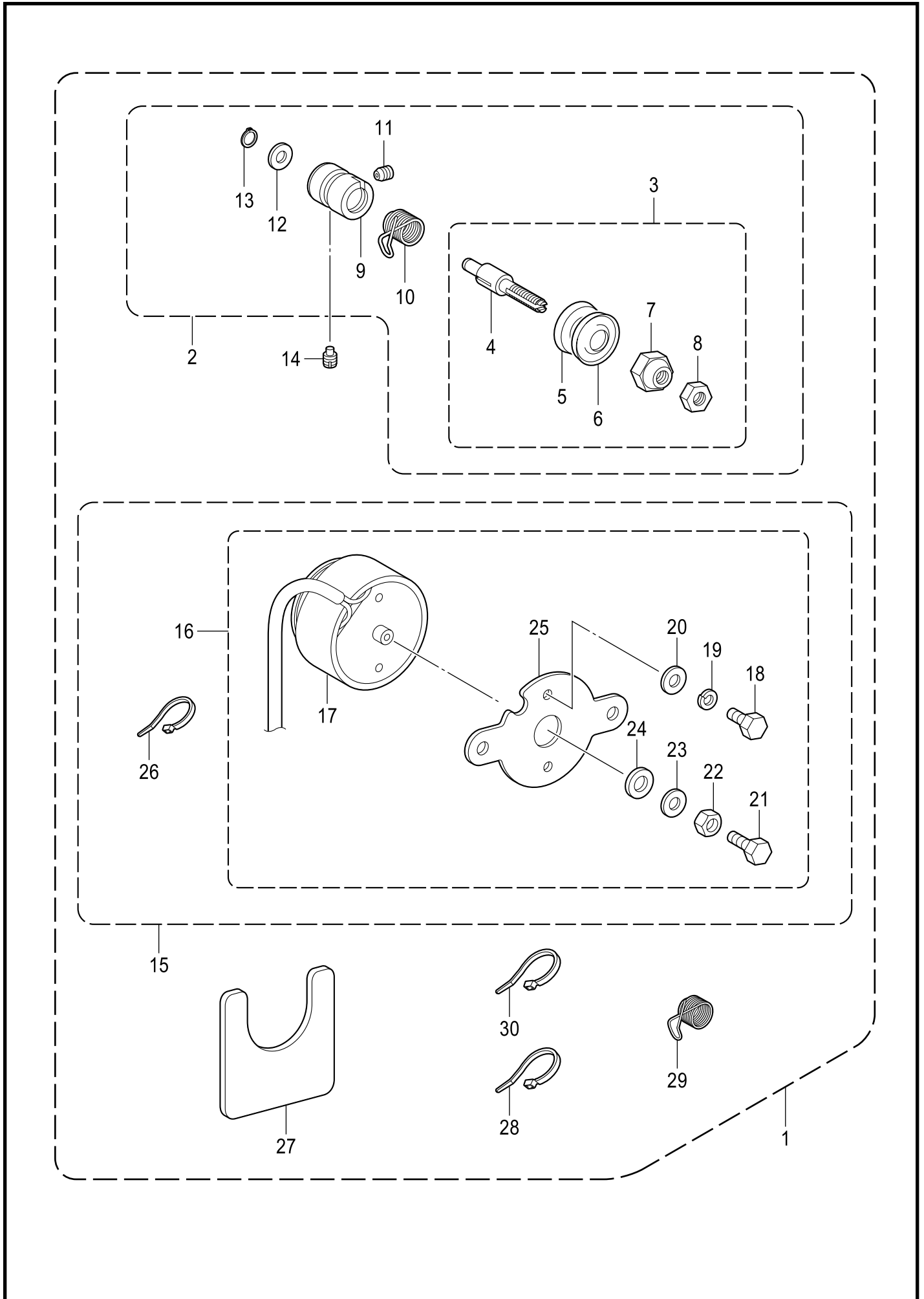

W2. 付属装置関係 (オプション部品) / Attachment set (Option parts)

REF.NO	CODE	Q'TY	品名	NAME OF PARTS	RM
1	SA5436201	1	<欧州向用以外> DTテンションセット	<Except for Europe> DT TENSION SET	
1	SA54362E1	1	<欧州向用> DTテンションセット	<For Europe only> DT TENSION SET	
2	SA7509101	1	DTイトチヨウシダイクミ	TENSION BRACKET ASSY	
3	SA7513001	1	DTイトチヨウシサラクミ	DT TENSION DISC ASSY	
4	SA7510001	1	DTイトチヨウシボウ	DT TENSION STUD	
5	SA6190001	1	DTイトチヨウシサラ	DISC DT	
6	145446001	1	イトチヨウシサラ	DISC, TENSION	
7	SA3638001	1	DTチヨウシサラナツト	DT NUT	
8	021060306	1	3シュナツト6	NUT 3 M6	
9	SA7511001	1	DTイトチヨウシダイ	DT TENSION BRACKET	
10	SA6193201	1	イトトリバネC	THREAD TAKE-UP SPRING C	
11	013679412	1	トメネジ3.57クボミ	SET SCREW, (CP) SM3.57	
12	SA4932001	1	ザガネ	WASHER	
13	048060142	1	トメワジクヨウC6	RETAINING RING EXTERNAL C6	
14	SA7512001	1	トメネジ	SET SCREW	
15	SA5331001	1	<欧州向用以外> イトユルメソウクミ	<Except for Europe> TENSION RELEASE SET	
15	SA75410E1	1	<欧州向用> イトユルメWEEEソウクミ	<For Europe only> TENSION RELEASE WEEE SET	
16	SA5133001	1	イトユルメクミ	TENSION RELEASE ASSY	
17	SA4829001	1	Dテンションソレノイド	DEGITAL TENSION SOLENOID	
18	017400802	2	ボルト4X8	BOLT M4X8	
19	028040246	2	バネザガネ2-4	WASHER SPRING 2-4	
20	026040236	2	ヒラザガネミガキ4	WASHER PLAIN M 4	
21	017401015	1	ボルト4X10	BOLT M4X10	
22	021400306	1	3シュナツト4	NUT 3 M4	
23	102707002	1	ザガネ	WASHER	
24	SA6284001	1	クツシヨン	CUSHION	
25	SA3345001	1	ソレノイドトリツケイタ	SETTING PLATE, SOLENOID	
26	S04159000	1	バインド1M	BAND 1M	
27	SA7508001	1	DTソレノイドイタ	DT SOLENOID PLATE	
28	218859001	2	バインダM150	BINDER M150	
29	145519301	1	イトトリバネ	THREAD TAKE-UP SPRING	
30	S04159000	2	バインド1M	BAND 1M	

W3 . 付属装置関係(オプション部品) / Attachment set (Option parts)

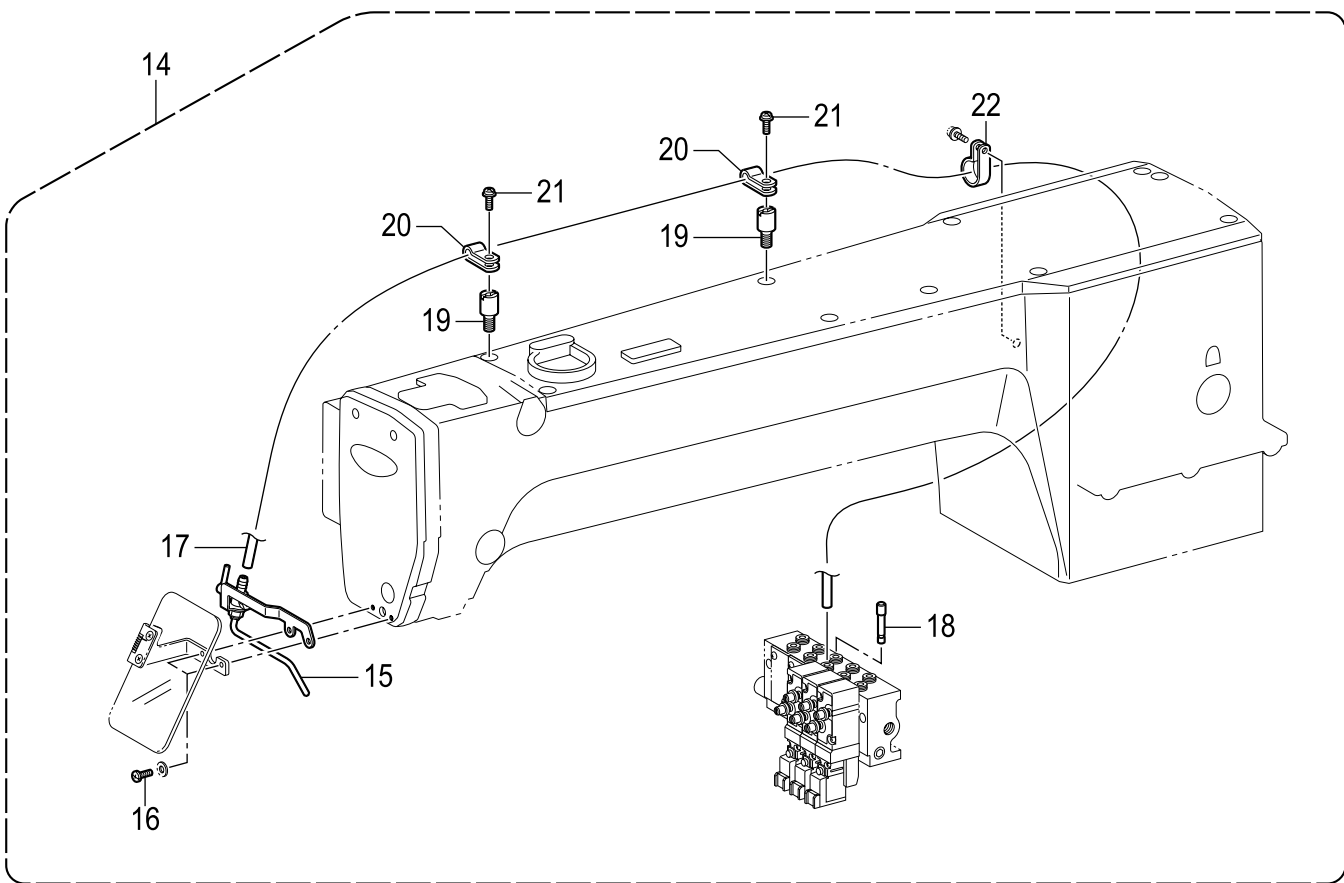
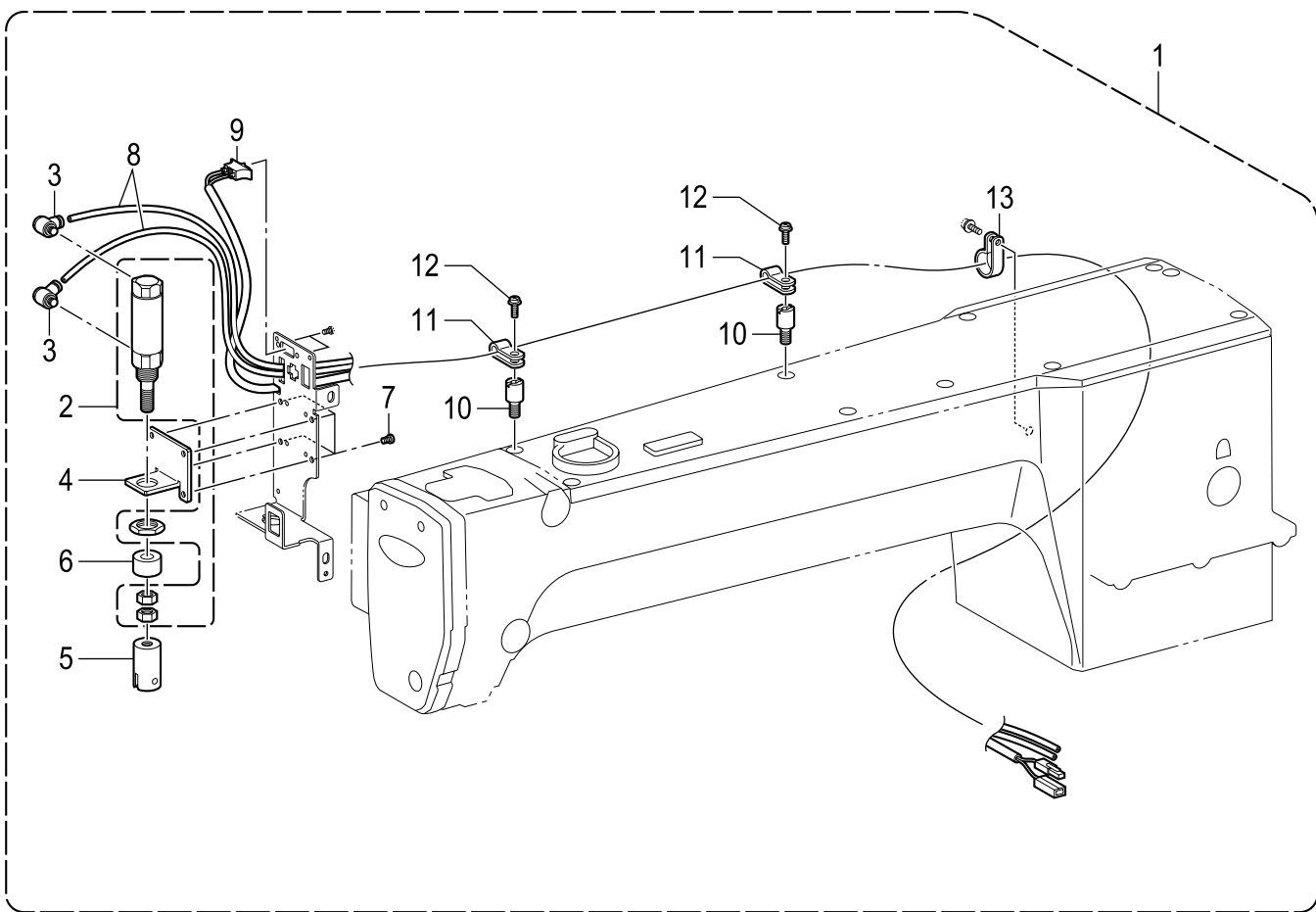

W3. 付属装置関係 (オプション部品) / Attachment set (Option parts)

REF.NO	CODE	Q'TY	品名	NAME OF PARTS	RM
1	SA5575101	1	<欧州向用以外> エアワイパーソウチセット	<Except for Europe> TR.WIPER SET PNEUMATIC TYPE	
2	S17942100	1	エアシリンダ	AIR CYLINDER	
1	SA55751E1	1	<欧州向用> エアワイパーソウチセット	<For Europe only> TR.WIPER SET PNEUMATIC TYPE	
2	SA74700E1	1	エアシリンダWEEE	AIR CYLINDER WEEE	
3	S55533000	2	エルボM5	ELBOW, M5	
4	SA7163001	1	シリンダトリツケイタ	CYLINDER SUPPORT PLATE	
5	SA7164001	1	シリンダツギテ	JOYNT CYLINDER	
6	S31778000	1	シリンダーストッパ	STOPPER, CYLINDER	
7	062350616	4	ナベコ35X6	SCREW PAN M3.5X6	
8	S15031010	2	エアチューブ	AIR TUBE, 4X2.5	
9	SA7620101	1	イトハライスイッチクミG	THREAD WIPER SWITCH ASSY G	
10	SA7155001	2	スペーサ	SPACER	
11	525664000	2	コードホルダ#6	CORD HOLDER #6	
12	0A5401006	2	+ナベザクミ4X10DB	SCREW PAN (S/P WASHER) M4X10	
13	552907000	1	コードホルダ#10	CORD HOLDER #10	
14	SA5559101	1	ニードルクーラーソウチセット	NEEDLE COOLER SET	
15	S18027201	1	ニードルブロワー	NEEDLE BLOWER	
16	062400816	2	ナベコ4X8	SCREW PAN M4X8	
17	S15031010	1	エアチューブ	AIR TUBE, 4X2.5	
18	S04897000	1	プラグ4	PLUG 4	
19	SA7155001	2	スペーサ	SPACER	
20	S10243000	2	ナイロンクランプNK-3N	CORD HOLDER, NK-3N	
21	0A5401006	2	+ナベザクミ4X10DB	SCREW PAN (S/P WASHER) M4X10	
22	525907000	1	コードホルダ#9	CORD HOLDER #9	

W4 . 付属装置関係(オプション部品) / Attachment set (Option parts)

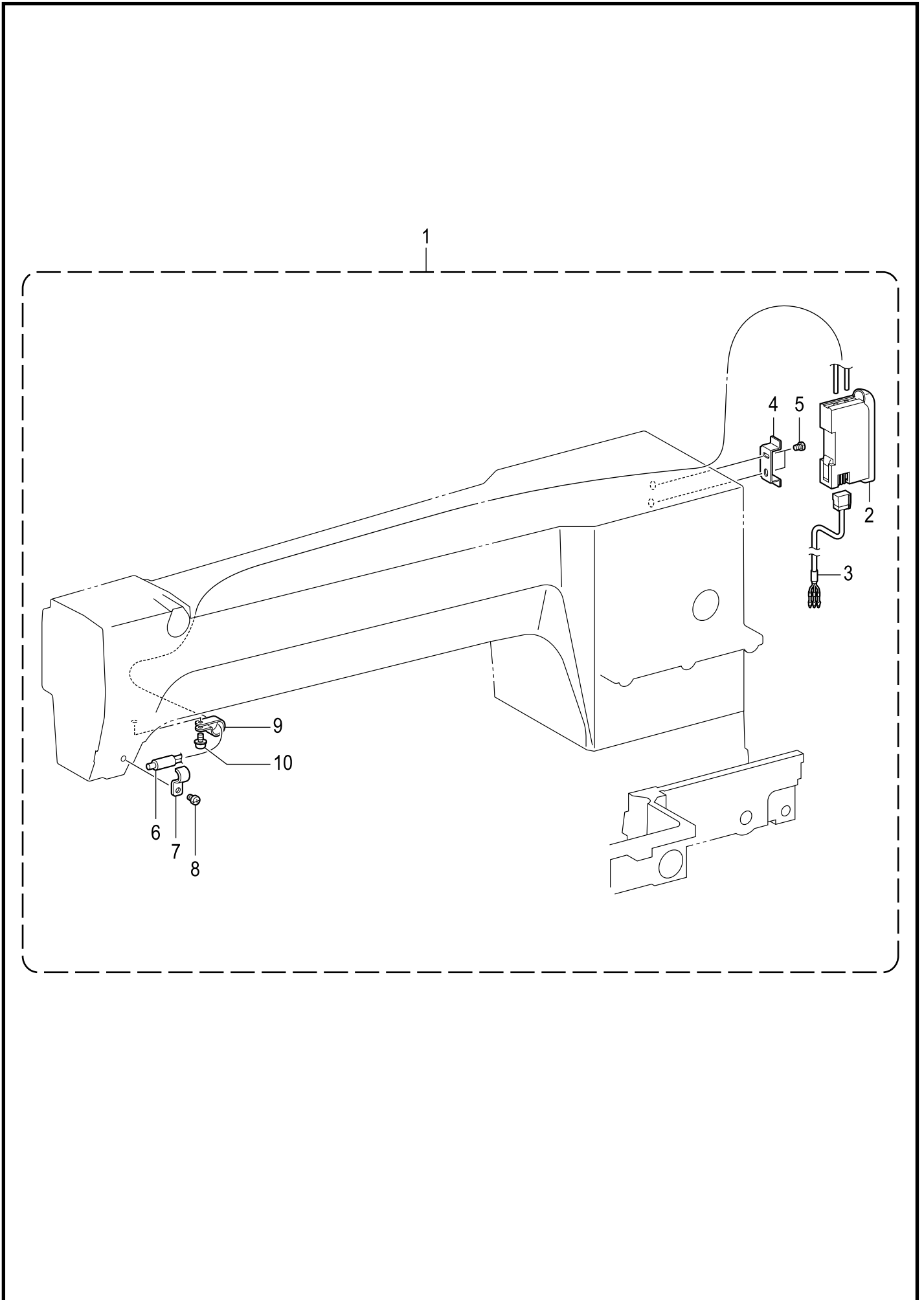

W4. 付属装置関係 (オプション部品) / Attachment set (Option parts)

REF.NO	CODE	Q'TY	品名	NAME OF PARTS	RM
1	SA5193101	1	<欧州向用以外> イトキレカンチソウチクミF	<Except for Europe> TR-BREAKAGE DETECTOR SET F	
1	SA51931E1	1	<欧州向用> イトキレカンチソウチクミF	<For Europe only> TR-BREAKAGE DETECTOR SET F	
2	SA4816001	1	ファイバアンプFX311	FIBER AMP FX311	
3	SA4817001	1	アンプケーブルクミ	AMP CABLE ASSY	
4	SA4818001	1	アンプトリツケDINカナグ	DIN METAL FITTING	
5	062300616	2	ナベコ3X6	SCREW PAN M3X6	
6	SA4819001	1	ファイバFDFM2	FIBER FDFM2	
7	SA5194001	1	センサトリツケイタ	SENSOR SETTING PLATE	
8	062500616	1	ナベコ5X6	SCREW PAN M5X6	
9	625010000	1	ナイロンクランプNK-2N	NYLON CLAMP NK-2N	
10	0A5401006	1	+ナベザクミ4X10DB	SCREW PAN (S/P WASHER) M4X10	

W5 . 付属装置関係(オプション部品) / Attachment set (Option parts)

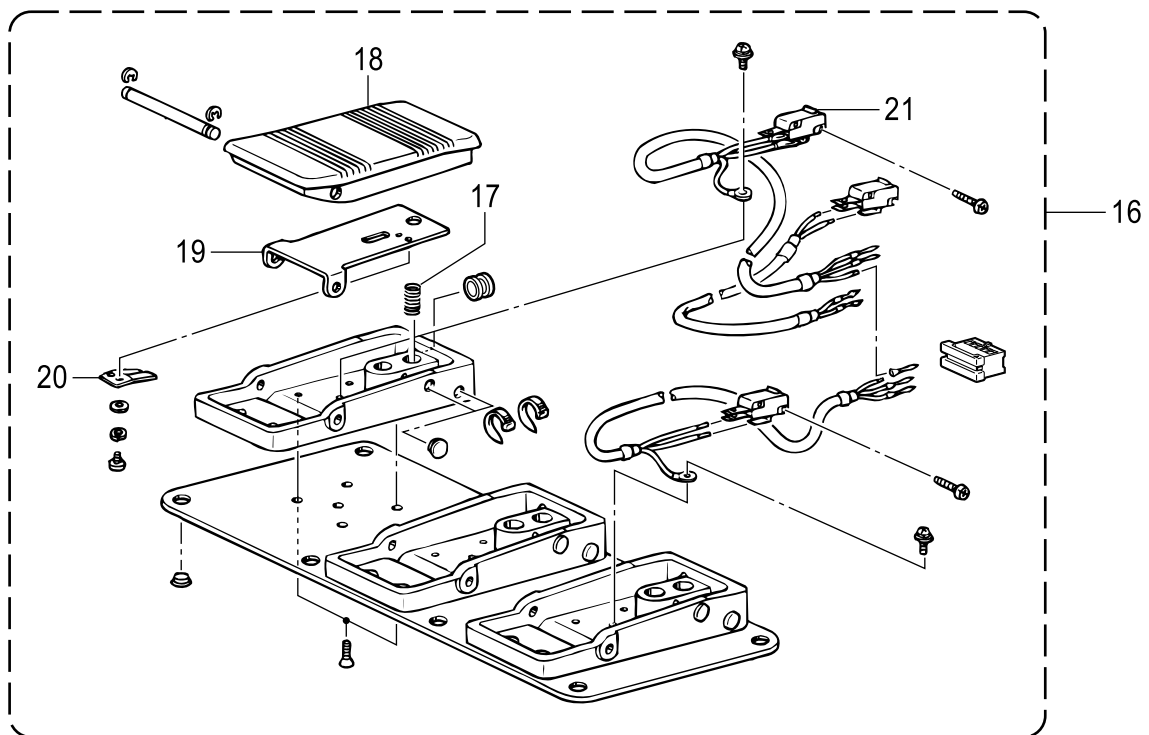
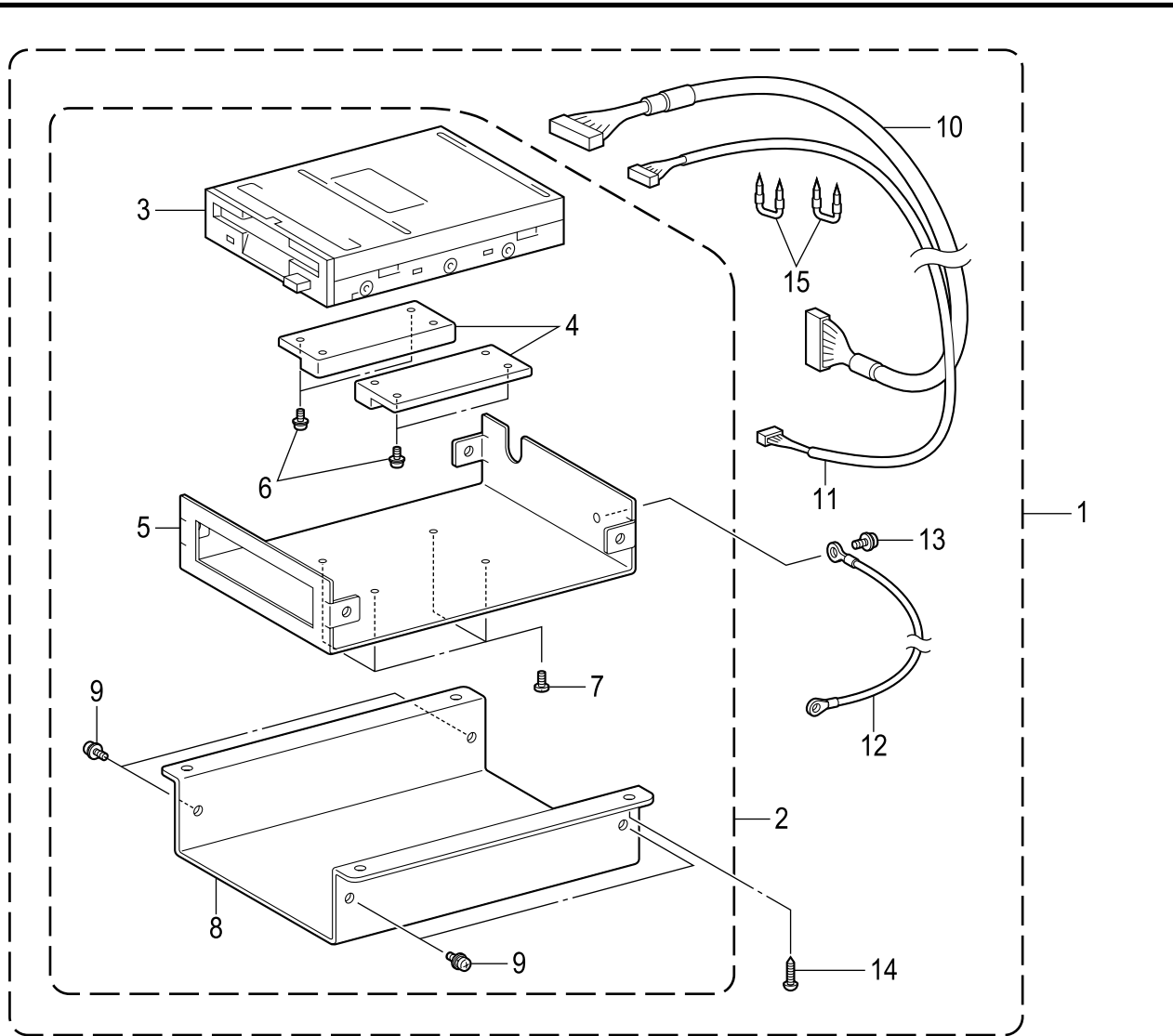

W5. 付属装置関係 (オプション部品) / Attachment set (Option parts)

REF.NO	CODE	Q'TY	品名	NAME OF PARTS	RM
			<欧州向用以外>	<Except for Europe>	
1	SA5201001	1	FDDセット	FDD SET	
2	SA5202001	1	FDDユニットクミ	FDD UNIT ASSY	
3	SA6628101	1	FDD	FDD	
4	S43225000	2	FDDスペーサ	SPACER, FDD	
5	SA5203001	1	FDDベースイタ	FDD BASE PLATE	
6	0A4300605	4	+ナベザクミ3X6DA	SCREW PAN (S/P WASHER) M3X6	
7	037300816	4	Vナベタツピン3X8	TAPPING SCREW PAN V M3X8	
8	SA5204001	1	FDDカバー	FDD COVER	
9	0A4300805	4	+ナベザクミ3X8DA	SCREW PAN (S/P WASHER) M3X8	
10	SA5205001	1	FDDハーネス	FDD HARNESS	
11	SA5206001	1	FDDデンゲンハーネス	FDD POWER HARNESS	
12	SA5134001	1	アースセン	GROUND WIRE	
13	0A4300805	1	+ナベザクミ3X8DA	SCREW PAN (S/P WASHER) M3X8	
14	032421302	4	+2マルモク41X13	WOOD SCREW ROUND 2 M4.1X13	
15	200190001	2	ステツプル 10X20	STAPLE 10X20	
			<欧州向用>	<For Europe only>	
1	SA52010E1	1	FDDセット	FDD SET	
2	SA52020E1	1	FDDユニットクミ	FDD UNIT ASSY	
3	SA6628101	1	FDD	FDD	
4	S43225000	2	FDDスペーサ	SPACER, FDD	
5	SA5203001	1	FDDベースイタ	FDD BASE PLATE	
6	0A4300605	4	+ナベザクミ3X6DA	SCREW PAN (S/P WASHER) M3X6	
7	037300816	4	Vナベタツピン3X8	TAPPING SCREW PAN V M3X8	
8	SA5204001	1	FDDカバー	FDD COVER	
9	0A4300805	4	+ナベザクミ3X8DA	SCREW PAN (S/P WASHER) M3X8	
10	SA5205001	1	FDDハーネス	FDD HARNESS	
11	SA5206001	1	FDDデンゲンハーネス	FDD POWER HARNESS	
12	SA5134001	1	アースセン	GROUND WIRE	
13	0A4300805	1	+ナベザクミ3X8DA	SCREW PAN (S/P WASHER) M3X8	
14	032421302	4	+2マルモク41X13	WOOD SCREW ROUND 2 M4.1X13	
15	200190001	2	ステツプル 10X20	STAPLE 10X20	
			<欧州向用以外>	<Except for Europe>	
16	SA6495001	1	3レンフットSWクミ	3-PEDAL FOOT SW ASSY	
17	S38170001	3	フットペダルバネ	FOOT PEDAL SPRING	
18	S38174000	3	フットペダル	FOOT PEDAL	
19	S38175101	3	ペダルホゴイタ	PROTECTION PLATE PEDAL	
20	S38176101	3	スイッチオサエバネ	SPRING, PLATE	
21	S36260000	1	スイッチVXピンボタン	MICRO SWITCH: VX-01-1A3	
			<欧州向用>	<For Europe only>	
16	SA64950E1	1	3レンフットSWクミ	3-PEDAL FOOT SW ASSY	
17	S38170001	3	フットペダルバネ	FOOT PEDAL SPRING	
18	S38174000	3	フットペダル	FOOT PEDAL	
19	S38175101	3	ペダルホゴイタ	PROTECTION PLATE PEDAL	
20	S38176101	3	スイッチオサエバネ	SPRING, PLATE	
21	S36260000	1	スイッチVXピンボタン	MICRO SWITCH: VX-01-1A3	



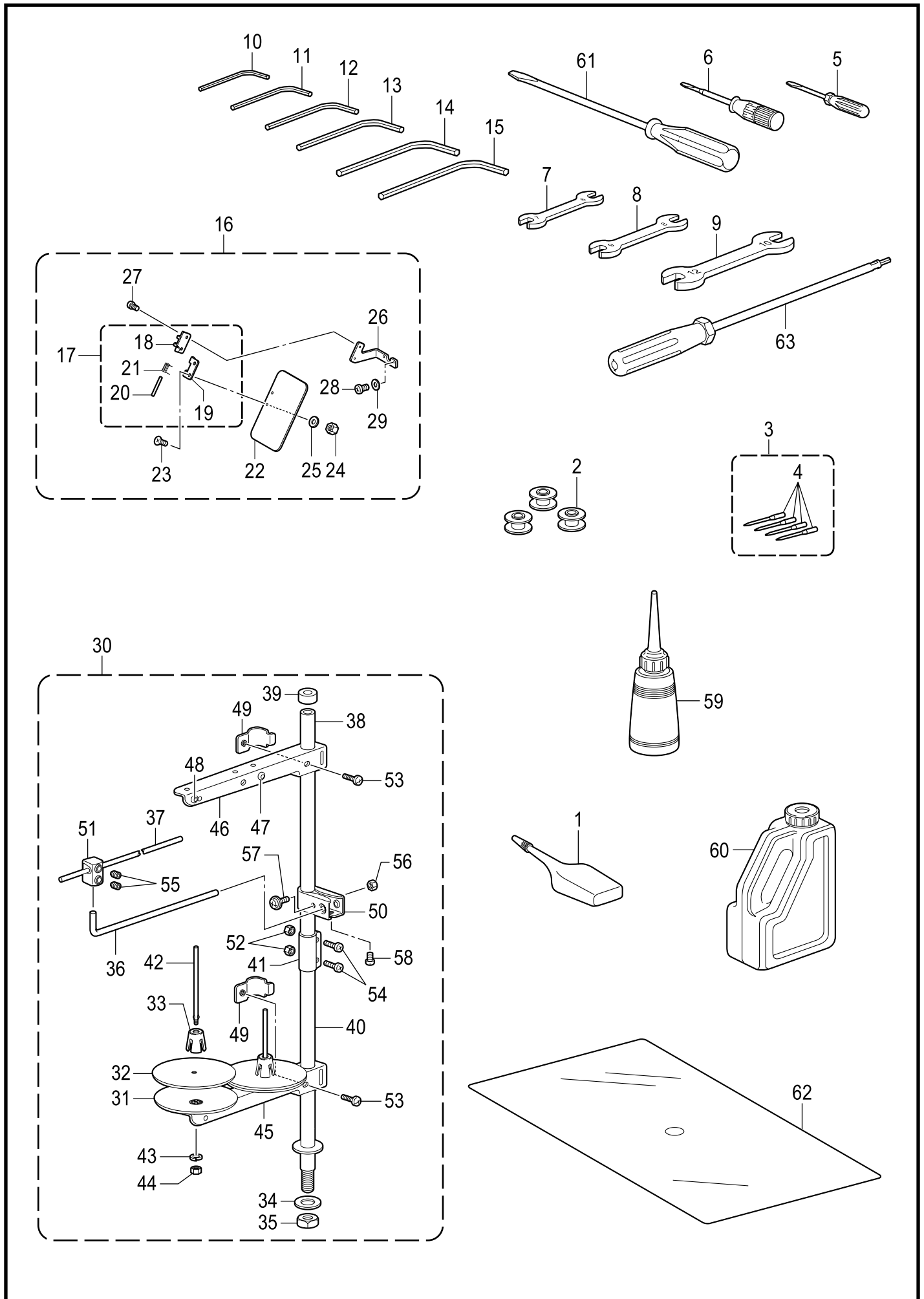



Z. 付属品関係 / Accessories



Z. 付属品関係 / Accessories

REF.NO	CODE	Q'TY	品名	NAME OF PARTS	RM
1	S06706001	1	シリコンオイル	SILICONE OIL	
2	S44633001	3	ボビンLAN	BOBBIN LAN	
3	SA1645019	1	145646ハリ4コイリクミ	NEEDLE 4PIECE ASSY, 145646	
4	145646019	4	ミシンハリDPX17	NEEDLE, DPX17	
5	142443001	1	ネジマワシ1.9X52	SCREW-DRIVER, 1.9X52	
6	118837001	1	ネジマワシ3.4X70	SCREW-DRIVER, 3.4X70	
7	107779001	1	スパナ6X7	WRENCH, 6X7	
8	100887001	1	スパナ8X9	WRENCH, 8X9	
9	107780001	1	スパナ10X12	WRENCH, 10X12	
10	S07783001	1	6カクボウスパナ1.5	HEXAGONAL WRENCH, 1.5	
11	142002001	1	6カクボウスパナ2	HEXAGONAL WRENCH, 2	
12	154125001	1	6カクボウスパナ2.5	HEXAGONAL WRENCH, 2.5	
13	142721001	1	6カクボウスパナ3	HEXAGONAL WRENCH, 3	
14	118064001	1	6カクボウスパナ4	HEXAGONAL WRENCH, 4	
15	150335001	1	6カクボウスパナ5	HEXAGONAL WRENCH, 5	
16	SA4103001	1	アイガードセットD	EYE GUARD SET D	
17	S44483001	1	チヨウバンクミ	HINGE ASSY	
18	S44484001	1	アイガードヒンジ	EYE GUARD HINGE	
19	S37619001	1	ソデイタチヨウバンタイ	HINGE	
20	119255000	1	ソデイタチヨウバンピン	PIN	
21	S37113001	1	アイガードバネ	EYE GUARD SPRING	
22	S44485001	1	アイガード	EYE GUARD	
23	061300813	2	サラコ3X8	SCREW FLAT M3X8	
24	021300103	2	1シュナット3	NUT, 1 M3	
25	026030233	2	ヒラザガネミガキ3	WASHER PLAIN M 3	
26	SA4104001	1	アイガードホルダ-A	EYE GUARD HOLDER, A	
27	062300503	2	ナベコ3X5	SCREW, PAN M3X5	
28	062400616	2	ナベコ4X6	SCREW PAN M4X6	
29	026040136	2	ヒラザガネコガタ4	WASHER PLAIN S 4	
30	S40574309	1	イトタテダイクミ2DTHF	COTTON STAND ASSY 2DTHF	
31	S51283001	2	ウケザラ	SPOOL STAND BASE	
32	150182000	2	スプ-ルマット	SPOOL MAT	
33	S51282101	2	スプ-ルクツシヨン	SPOOL CUSHION	
34	150206002	1	ヒラザガネ16	WASHER PLAIN 16	
35	SA6629001	1	6カクナットM16	NUT M16	
36	S04109001	1	イトアンナイササエボウ	THREAD GUIDE SUPPORT BAR	
37	142997001	1	イトアンナイ3	THREAD GUIDE, 3	
38	150172003	1	コラムパイプ	COLUMN PIPE	
39	150174000	1	コラムキャップ	COLUMN CAP	
40	156112003	1	コラムパイプD	COLUMN PIPE D	
41	SA6606001	1	コラムジョイント	COLUMN JOINT	
42	150179002	2	スプ-ルジクB	SPOOL SHAFT B	
43	028050244	2	バネザガネ2-5	WASHER SPRING 2-5	
44	021500104	2	1シュナット5	NUT 1 M5	
45	SA6607001	1	スプ-ルホルダ-2	SPOOL HOLDER 2	
46	SA6607001	1	スプ-ルホルダ-2	SPOOL HOLDER 2	
47	150183000	2	イトカケハンガ-ダイ	THREAD HANGER BASE	
48	142990001	2	スレツドブツシユ	THREAD BUSH	
49	SA6609001	2	スプ-ルホルダ-ササエ	SPOOL HOLDER SUPPORTER	
50	SA6615001	1	イトアンナイホルダ-	THREAD GUIDE HOLDER	
51	138843001	1	ササエボウツギテ	JOINT	
52	021500104	2	1シュナット5	NUT 1 M5	
53	062061604	2	ナベコ6X16	SCREW PAN M6X16	
54	062501404	2	ナベコ5X14	SCREW PAN M5X14	
55	014060632	2	アナクボミ6X6	SET SCREW SOCKET (CP) M6X6	
56	021500104	1	1シュナット5	NUT 1 M5	
57	S37037001	1	ナベコヒラザ5X32	SCREW PAN (S/P WASHER) M5X32	
58	062061004	1	ナベコ6X10	SCREW PAN M6X10	
59	114483002	1	ポリオイラ-クミ	OILER ASSY	
60	S55663001	1	オイルタンククミ	OIL TANK ASSY	
61	101572102	1	ネジマワシ5.5X190	SCREW-DRIVER 5.5X190	
62	SA8855001	1	ハリイタホジョイタシート	AUXILIARY PLATE SEET	
63	149173001	1	6カクボウネジマワシ3	SCREW-DRIVER, HEXAGONAL 3	

Wa. 警告ラベル / Warning labels

警告ラベル / Warning labels	品名 / Name of parts	Size(mm)	Code
	<p>ラベル感電6ヶ国 Label, elec. shock 6 lang</p>	50 X 118	J04115-001
	<p>ラベル注意・和英 Label, caution Jpn / Eng</p>	52 X 84	SA0792-001
	<p>ラベル注意・中英 Label, caution Chn / Eng</p>	52 X 84	SA0793-001
	<p>ワーニングマーク Mark, injury</p>	L=25 R=1.2	S36924-002
	<p>アースマーク Label, grounding</p>	φ 12	S37060-001
	<p>PE マーク Label, PE</p>	7.5 X 12.5	S37059-001

Ap . 用途別部品一覧表 / Parts list sorted by application

BAS-342G には下記部品が用意されていますので、幅広い用途にご活用ください。











◎表中の部品は、BAS-311G, 326G (ダイレクトドライブプログラム式電子ミシン)と共通です。

◎表中の☆の部品は、BAS-341F, 342F (プログラム式電子ミシン) と共通です。

The following parts are available for the BAS-342G to enable use for a wide range of applications.

◎The parts in the table are common to the BAS-311G and BAS-326G (Direct drive programmable electronic pattern sewers) .

◎In the following table, parts marked with ☆ are common to the BAS-341F and BAS-342F (Programmable electronic pattern sewers with cylinder bed) .

品名 Part name	用途 Use	厚物 Heavy-weight materials	中厚物 Medium-weight materials	エアバッグ Airbag
(J-66) 針穴板 Needle hole plate		(φ2.4) SA3336-101	(φ2.2) SA5221-001	(φ3.0) SA5222-101
(E-47) ボビンケース組 Bobbin case assy		S59221-201 < LC >		S59222-201 < LD >
(E-48) ボビンケース 調子ばね Tension spring		S48664-001 < AN >		S16075-101 < B >
(E-49) ボビンケース ばねねじ Screw			S16492-101	
(E-50) 空転防止ばね Anti-spin spring			S15667-001	
(E-51) ボビン Bobbin		S44633-001 < LAN >		S15666-001 < LB >
(E-52) 中がま箱組 Shuttle hook assy, w/box		SA8197-101 < LH >	SA2173-301 < LF >	SA8197-101 < LH >
(E-46) 大がま Shuttle race base		152686-201 < B >	152682-201 < A >	152686-201 < B >
(G-12) 糸調子ばね Spring, tension		107606-101	104525-101	107606-101
(G-8) 糸取りばね Thread take-up spring		144588-301	145519-301	144588-301

Ap . 用途別部品一覧表 / Parts list sorted by application

BAS-342G には下記部品が用意されていますので、幅広い用途にご活用ください。







◎表中の部品は、BAS-311G, 326G (ダイレクトドライブプログラム式電子ミシン)と共通です。

◎表中の☆の部品は、BAS-341F, 342F (プログラム式電子ミシン) と共通です。

The following parts are available for the BAS-342G to enable use for a wide range of applications.

◎The parts in the table are common to the BAS-311G and BAS-326G (Direct drive programmable electronic pattern sewers).

◎In the following table, parts marked with ☆ are common to the BAS-341F and BAS-342F (Programmable electronic pattern sewers with cylinder bed).

品名 Part name	用途 Use	厚物 Heavy-weight materials	中厚物 Medium-weight materials	エアバッグ Airbag
(G-21) 副調子ばね Spring, tension 		SA4146-101		SA3416-101
(W1-30) 調子ばね上ザガネ Washer 		—		S20681-000
(G-25) 針棒糸案内 Needle bar thread guide  A  B		SA3257-101 < A >		SA4815-101 < B >
(Z-3) ミシン針4個入り組 Needle assy 		☆ SA1645-019	☆ SA1752-016	☆ SA1645-025
(B-32, Z-4) 針 Needle		☆ DP X 17 <#19 > 145646-019	☆ DP X 5 <#16 > 107415-016	☆ DP X 17 <#25 > 145646-025
(D1-61) 押え足 Presser foot 		☆ S42843-001 < A >		☆ S42844-001 < B >

Ga . ゲージ部品一覧表 / Gauge parts list

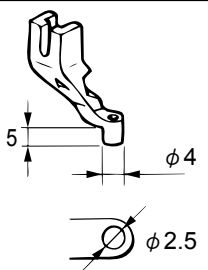
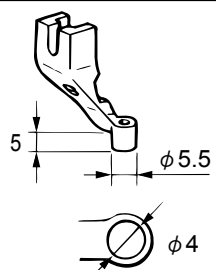
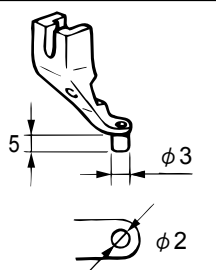
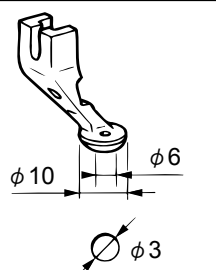
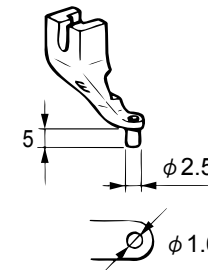
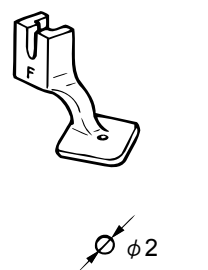
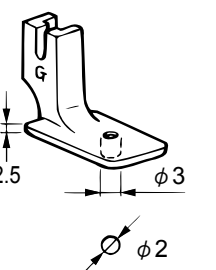
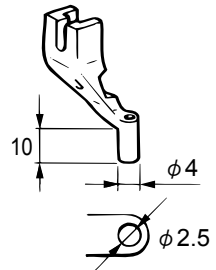
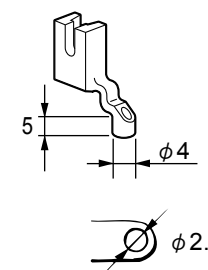
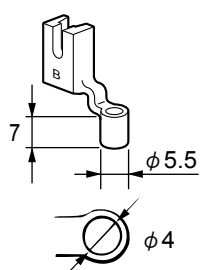
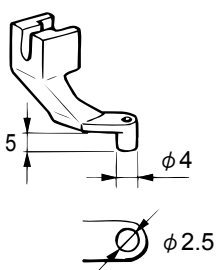
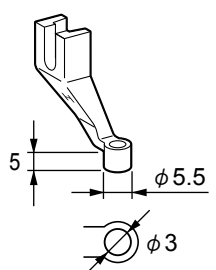
押え足 / Presser foot			
A / S42843-001 *	B / S42844-001	C / S42845-001	D / S42846-001
			
E / S42847-001	F / 157237-001	G / 158592-001	J / S42848-001
			
A-CUT / S40214-001	B-L / S49448-001	XA / S42849-101	H / SA4811-001
			

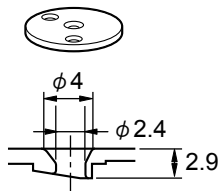
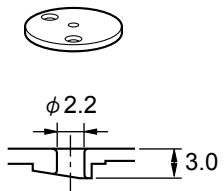
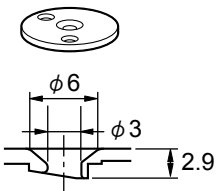
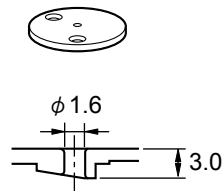
針穴板 / Needle hole plate			
2.4 C0.4 / SA3336-101 *	2.2 / SA5221-001	3.0 C1.5 / SA5222-101	1.6 / SA7191-001
			

* 印の部品は、標準部品です。

The * symbol is for Standard parts.

索引 / Index

CODE	REF.NO	Page	CODE	REF.NO	Page	CODE	REF.NO	Page	CODE	REF.NO	Page
004300513	A1 - 17	2	017401015	W2 - 21	60	021500106	R - 17	48	062060816	F - 21	22
012060536	B - 33	8	017401415	L - 5	36	025030236	J - 65	32	062061004	Z - 58	68
	D1 - 59	16	018061236	D2 - 28	18		J - 70	32	062061016	A1 - 14	2
	E - 6	20	018064031	A2 - 23	6	025040236	D2 - 12	18		F - 3	22
012060636	A1 - 39	2	018066036	C1 - 17	10		F - 74	24		H - 38	28
	A2 - 2	6	018081636	R - 9	48		K - 11	34	062061604	Z - 53	68
	A2 - 11	6	018087036	A2 - 7	6		M1 - 18	38	062061616	A1 - 44	2
	A2 - 26	6		A2 - 13	6	025050236	L - 13	36	062300416	C1 - 36	10
	B - 24	8	018300536	C1 - 4	10		R - 15	48		D1 - 20	16
	B - 49	8		C1 - 8	10		U - 23	54		J - 64	32
	C2 - 12	12	018300836	C3 - 36	14	025050336	R - 16	48		J - 71	32
	C2 - 15	12	018301036	C1 - 10	10	025080132	A2 - 29	6	062300503	Z - 27	68
	C2 - 26	12	018302036	W1 - 11	58	025080236	U - 19	54	062300506	A1 - 20	2
	C2 - 28	12	018400636	D2 - 17	18	025350332	A1 - 30	2	062300616	E - 29	20
	C2 - 40	12		F - 7	22	026030136	E - 28	20		K - 7	34
	C2 - 47	12		R - 8	48	026030233	Z - 25	68		W4 - 5	64
	C3 - 10	14	018400836	C1 - 2	10	026040136	F - 24	22	062300816	Q - 6	46
	C3 - 14	14		C1 - 6	10		Z - 29	68	062350616	H - 8	28
	D1 - 14	16		C2 - 50	12	026040236	J - 7	30		W3 - 7	62
	D1 - 24	16		D1 - 52	16		L - 4	36	062400616	D1 - 6	16
	D1 - 30	16		K - 10	34		W2 - 20	60		D2 - 11	18
	D1 - 36	16	018401036	C1 - 19	10	028030246	J - 69	32		D2 - 30	18
	D2 - 7	18		C1 - 26	10	028040246	F - 75	24		F - 4	22
	D2 - 15	18		D2 - 5	18		J - 6	30		F - 8	22
	D2 - 19	18	018401236	C1 - 12	10		L - 3	36		F - 23	22
	D2 - 25	18	018401636	B - 27	8		W2 - 19	60		Z - 28	68
	D2 - 27	18	018402036	E - 12	20	028050244	Z - 43	68	062400816	B - 22	8
	E - 9	20		F - 72	24	028050246	J - 50	30		B - 35	8
	E - 16	20	018402536	D1 - 64	16		P - 22	44		C2 - 33	12
	E - 18	20	018501036	D2 - 3	18	028060246	A2 - 20	6		W3 - 16	62
	G - 28	26	018501236	C1 - 14	10	028080246	A2 - 8	6	062401006	A1 - 23	2
	J - 46	30		E - 43	20		A2 - 14	6		B - 47	8
	J - 54	30		J - 49	30		U - 5	54	062401016	B - 52	8
012061036	E - 20	20	018501636	B - 3	8		U - 15	54		C1 - 37	10
	E - 41	20		B - 50	8		U - 20	54	062401216	H - 13	28
012400436	D1 - 25	16		C2 - 38	12		U - 26	54	062500616	G - 2	26
	D1 - 31	16		C2 - 45	12	032361306	A2 - 4	6		G - 4	26
	H - 17	28	018503036	P - 23	44		U - 29	54		G - 6	26
	H - 24	28	021060106	A2 - 21	6	032421302	W5 - 14	66		H - 30	28
	J - 9	30		A2 - 24	6	032422003	P - 27	44		W4 - 8	64
012500536	B - 21	8		D1 - 10	16		P - 30	44	062500816	C3 - 37	14
	B - 37	8		D1 - 50	16	037300816	W5 - 7	66	062501404	Z - 54	68
	B - 44	8		J - 23	30	037521016	U - 22	54	062670412	G - 31	26
	C2 - 5	12		J - 34	30	039411215	U - 34	54	070696800	D2 - 22	18
	C2 - 21	12		J - 40	30	047401242	B - 42	8	076202850	C2 - 16	12
	D2 - 24	18	021060206	C3 - 25	14	048030342	C3 - 30	14		C2 - 30	12
	E - 14	20	021060306	D1 - 41	16		K - 20	34	081003670	E - 22	20
	E - 45	20		J - 25	30	048040342	C3 - 17	14	081007070	L - 17	36
	H - 3	28		J - 32	30		J - 20	30	0A4300605	W5 - 6	66
	H - 36	28		J - 42	30		K - 13	34	0A4300606	K - 8	34
013679412	W2 - 11	60		W2 - 8	60		L - 12	36	0A4300805	W5 - 9	66
014060632	Z - 55	68	021080106	U - 25	54	048050342	H - 10	28		W5 - 13	66
016061031	D2 - 14	18	021160303	U - 9	54		H - 19	28	0A5401005	P - 8	44
017061213	D1 - 12	16	021300103	A1 - 21	2	048060142	C3 - 20	14	0A5401006	A1 - 42	2
017061612	D1 - 48	16		Z - 24	68		W2 - 13	60		A1 - 46	2
017065002	D1 - 49	16	021400106	M1 - 17	38	048060342	A2 - 30	6		A1 - 48	2
017080006	U - 14	54	021400206	A1 - 56	2	048080142	C3 - 12	14		A1 - 50	2
017081606	U - 4	54	021400306	G - 24	26		D1 - 29	16		A1 - 52	2
	U - 18	54		L - 6	36		J - 45	30		C1 - 39	10
	W1 - 22	58		W2 - 22	60	048100142	D2 - 10	18		F - 28	22
017400802	J - 5	30	021500104	Z - 44	68	048150142	C2 - 10	12		F - 30	22
	L - 2	36		Z - 52	68	060400516	K - 22	34		F - 33	22
	W2 - 18	60		Z - 56	68	061300813	Z - 23	68		F - 66	24

CODE	REF.NO	Page	CODE	REF.NO	Page	CODE	REF.NO	Page	CODE	REF.NO	Page
0A5401006	F - 67	24	144588301	G - 8	26	213650001	A2 - 9	6	S12150000	W1 - 12	58
	Q - 4	46		Ap	70		A2 - 15	6	S12441001	G - 11	26
	Q - 15	46	145446001	G - 14	26		A2 - 19	6		H - 35	28
	Q - 17	46		G - 22	26	218859001	Q - 31	46	S12699000	G - 18	26
	Q - 23	46		W2 - 6	60		W2 - 28	60	S13399001	D1 - 62	16
	Q - 24	46	145446002	H - 32	28	222372001	U - 24	54	S15031008	W1 - 23	58
	Q - 30	46	145465001	B - 23	8	228475000	P - 9	44	S15031010	W3 - 8	62
	W1 - 26	58	145519301	W2 - 29	60	231071001	J - 27	30		W3 - 17	62
	W3 - 12	62		Ap	70	525567000	F - 27	22	S15158009	U - 31	54
	W3 - 21	62	145547001	F - 22	22		Q - 29	22	S15666001	Ap	70
	W4 - 10	64	145646019	B - 32	8		F - 1	46	S15667001	E - 50	20
0A5402005	A1 - 33	2		Z - 4	68	525664000	P - 6	44		Ap	70
	A1 - 36	2		Ap	71		W3 - 11	62	S16075101	Ap	70
0A5403006	Q - 27	46	145646025	Ap	71	525907000	W1 - 27	58	S16492101	E - 49	20
100136001	G - 20	26	146058001	W1 - 18	58		W3 - 22	62		Ap	70
100360003	J - 67	32	146059001	W1 - 17	58		F - 31	22	S17942100	W3 - 2	62
100401022	H - 33	28	146060000	W1 - 16	58		W3 - 13	62	S17974101	A2 - 27	6
100402004	G - 16	26	146206009	W1 - 19	58	554482000	F - 32	22	S17975100	A2 - 28	6
100887001	Z - 8	68	146288001	K - 23	34		P - 29	44	S18027201	W3 - 15	62
101073001	U - 30	54	146354002	C3 - 16	14		Q - 28	46	S20164001	A1 - 3	2
101121100	U - 28	54		J - 51	30	623033000	D1 - 4	16		A1 - 4	2
101572102	Z - 61	68	148847001	P - 28	44	625010000	Q - 3	46	S20681000	W1 - 30	58
102707002	L - 7	36	149097000	K - 17	34		W4 - 9	64		Ap	71
	W2 - 23	60	149173001	Z - 63	68	J04115001	M1 - 10	38	S23418002	H - 15	28
104449001	A1 - 9	2	149547000	P - 7	44		Wa	69	S23651001	B - 8	8
	A1 - 12	2		Q - 2	46	J80991001	S - 1	50		B - 11	8
104450101	A1 - 5	2		Q - 16	46	S00470000	Q - 29	46		B - 14	8
	F - 59	22	149796001	P - 25	44	S00480000	W1 - 25	58		B - 17	8
104525101	Ap	70	150172003	Z - 38	68	S00705001	J - 61	30		B - 45	8
104567101	F - 10	22	150174000	Z - 39	68	S02429201	E - 24	20		D1 - 5	16
104821001	A1 - 2	2	150179002	Z - 42	68	S02652001	J - 11	30		D1 - 15	16
107415016	Ap	71	150182000	Z - 32	68	S02739000	U - 33	54		E - 8	20
107606101	G - 12	26	150183000	Z - 47	68	S02740000	U - 32	54		H - 40	28
	Ap	70	150206002	Z - 34	68	S03677001	K - 24	34		J - 2	30
107779001	Z - 7	68	150335001	Z - 15	68	S04109001	Z - 36	68		J - 26	30
107780001	Z - 9	68	150592001	A1 - 8	2	S04159000	D1 - 46	16	S25235001	B - 15	8
109763001	D2 - 23	18	152393200	U - 8	54		F - 73	24	S25279101	K - 15	34
110367001	B - 18	8	152682201	Ap	70		J - 12	30	S25310101	D1 - 37	16
	C3 - 11	14	152684101	E - 27	20		L - 10	36		J - 72	32
110735001	K - 19	34	152686201	E - 46	20		L - 18	36	S25454001	K - 14	34
111466121	D1 - 60	16		Ap	70		Q - 14	46	S25456001	K - 4	34
114483002	Z - 59	68	152881001	G - 27	26		Q - 32	46	S25475101	C3 - 24	14
114486002	A2 - 32	6	152883000	G - 29	26		W2 - 26	60		J - 33	30
117934001	H - 41	28	152884001	G - 30	26		W2 - 30	60	S31032001	G - 10	26
117936001	A1 - 6	2	152936001	H - 6	28	S04891000	P - 17	44		H - 34	28
118064001	Z - 14	68	152937001	H - 7	28	S04897000	W3 - 18	62	S31778000	W3 - 6	62
118837001	Z - 6	68	152948001	F - 11	22	S06706001	Z - 1	68	S32462001	J - 24	30
119255000	Z - 20	68	153049001	G - 7	26	S07350002	A1 - 27	2		J - 31	30
119702004	U - 27	54	153050000	E - 30	20	S07783001	Z - 10	68		J - 41	30
120265002	A1 - 26	2	153252000	P - 16	44	S09043000	F - 16	22	S32465101	J - 22	30
120448001	H - 23	28	153274001	P - 20	44	S09225001	U - 13	54		J - 39	30
133172003	U - 21	54	154125001	Z - 12	68	S09226001	U - 16	54	S34533001	W1 - 13	58
138843001	Z - 51	68	154596000	J - 30	30	S09228000	P - 15	44	S34534101	W1 - 14	58
141362001	D1 - 34	16	154599000	J - 10	30	S09312001	U - 6	54	S34706000	W1 - 10	58
142002001	Z - 11	68		L - 8	36	S09317109	U - 12	54	S36260000	T - 4	52
142211001	B - 25	8	155510001	W1 - 15	58	S10112101	D1 - 56	16		W5 - 21	66
142274101	F - 42	22	156112003	Z - 40	68	S10243000	W3 - 20	62	S36475000	A1 - 28	2
142443001	Z - 5	68	157237001	Ga	72	S10268001	H - 27	28	S36924002	A1 - 66	4
142721001	Z - 13	68	158592001	Ga	72	S10408000	R - 10	48		Wa	69
142990001	Z - 48	68	159486001	H - 9	28	S10438001	H - 18	28	S37037001	Z - 57	68
142997001	Z - 37	68		H - 25	28	S10470201	K - 21	34	S37059001	M1 - 11	38
144458001	B - 29	8	159805001	G - 13	26	S10661109	U - 7	54		Wa	69
144504001	W1 - 20	58	200190001	W5 - 15	66	S11531009	U - 17	54	S37060001	A1 - 68	4

索引 / Index

CODE	REF.NO	Page	CODE	REF.NO	Page	CODE	REF.NO	Page	CODE	REF.NO	Page
S37060001	M1 - 12	38	S53982000	W1 - 4	58	SA3283101	E - 44	20	SA3808101	M1 - 2	38
	Wa	69	S53983000	P - 32	44	SA3284101	E - 42	20	SA3827001	N - 8	42
S37113001	Z - 21	68	S55479001	C3 - 8	14	SA3290001	H - 2	28	SA3828001	N - 10	42
S37619001	Z - 19	68	S55481001	A1 - 61	2	SA3291001	H - 4	28	SA3831001	R - 2	48
S38168001	T - 2	52		C1 - 21	10	SA3293001	H - 11	28	SA3833201	R - 3	48
S38170001	T - 3	52		C3 - 39	14	SA3294001	H - 14	28	SA3838001	N - 11	42
	W5 - 17	66	S55484002	J - 13	30	SA3295001	H - 16	28	SA3946001	F - 64	24
S38174000	T - 5	52	S55485001	C3 - 22	14	SA3296001	H - 21	28	SA4103001	Z - 16	68
	W5 - 18	66		C3 - 35	14	SA3297001	H - 22	28	SA4104001	Z - 26	68
S38175001	T - 6	52		K - 26	34	SA3298001	H - 28	28	SA4143001	G - 17	26
S38175101	W5 - 19	66	S55487001	C3 - 42	14	SA3299001	H - 29	28	SA4146101	G - 21	26
S38176101	T - 7	52	S55533000	W3 - 3	62	SA3301101	J - 1	30		Ap	71
	W5 - 20	66	S55663001	Z - 60	68	SA3306001	A1 - 25	2	SA4171001	H - 5	28
S38265000	F - 41	22	S59221201	E - 47	20		J - 15	30	SA4172001	B - 4	8
S38266000	F - 69	24		Ap	70		L - 16	36	SA4173001	B - 4	8
S38713100	B - 34	8	S59222201	Ap	70	SA3307001	J - 8	30	SA4174001	B - 4	8
S39116100	P - 12	44	SA0792001	A1 - 67	4	SA3309101	J - 16	30	SA4175001	B - 4	8
	W1 - 3	58		Wa	69	SA3310001	J - 17	30	SA4177001	B - 10	8
	W1 - 7	58	SA0793001	A1 - 67	4	SA3311001	J - 18	30	SA4178001	B - 13	8
S40214001	Ga	72		Wa	69	SA3312201	J - 28	30	SA4179001	B - 6	8
S40574309	Z - 30	68	SA1174001	D1 - 53	16	SA3313101	J - 29	30	SA4180001	B - 7	8
S41205001	K - 3	34	SA1175001	D1 - 54	16	SA3315001	J - 21	30	SA4199001	E - 25	20
S41206001	K - 2	34	SA1283001	C2 - 3	12	SA3317001	J - 36	30	SA4302001	D1 - 9	16
S42446001	A1 - 65	4		C2 - 19	12	SA3319101	J - 43	30	SA4333001	G - 3	26
S42843001	D1 - 61	16	SA1359001	H - 37	28	SA3321001	J - 48	30	SA4354001	J - 56	30
	Ap	71	SA1645019	Z - 3	68	SA3334001	J - 62	30	SA4518001	J - 59	30
	Ga	72		Ap	71	SA3336101	J - 66	32	SA4519001	J - 60	30
S42844001	Ap	71	SA1645025	Ap	71		Ap	70	SA4545001	J - 44	30
	Ga	72	SA1752016	Ap	71		Ga	72	SA4546001	J - 35	30
S42845001	Ga	72	SA1984001	H - 12	28	SA3345001	W2 - 25	60	SA4563101	R - 4	48
S42846001	Ga	72	SA1988001	H - 26	28	SA3347001	L - 11	36	SA4574001	V - 8	56
S42847001	Ga	72	SA1994101	H - 31	28	SA3348001	L - 14	36	SA4596001	A1 - 1	2
S42848001	Ga	72	SA2161001	D1 - 28	16	SA3349001	L - 15	36	SA4600001	A1 - 11	2
S42849101	Ga	72	SA2173301	Ap	70	SA3387001	A2 - 18	6	SA4601001	A1 - 13	2
S43225000	W5 - 4	66	SA2195001	D1 - 58	16	SA3416101	W1 - 28	58	SA4603101	A1 - 15	2
S43236009	R - 11	48	SA2287001	K - 16	34		Ap	71	SA4604001	A1 - 24	2
S43674000	R - 12	48	SA2929001	F - 68	24	SA3441001	D2 - 21	18	SA4608101	B - 12	8
S43675000	R - 13	48	SA2958001	B - 20	8	SA3486001	Q - 21	46	SA4609101	B - 16	8
S44010001	A1 - 7	2	SA3040001	F - 57	22	SA3499001	B - 2	8	SA4622001	B - 28	8
S44483001	Z - 17	68	SA3055101	F - 60	22	SA3528001	B - 26	8	SA4624001	B - 43	8
S44484001	Z - 18	68		F - 70	24	SA3538001	C1 - 23	10	SA4626101	B - 38	8
S44485001	Z - 22	68	SA3060001	F - 56	22		C1 - 29	10	SA4627001	B - 39	8
S44633001	E - 51	20	SA3200101	A1 - 22	2		J - 73	32	SA4628101	B - 40	8
	Z - 2	68	SA3206001	B - 5	8	SA3581001	M1 - 13	38	SA4629001	B - 41	8
	Ap	70		B - 9	8	SA3638001	W2 - 7	60	SA4630001	B - 46	8
S44924001	E - 38	20	SA3224001	B - 31	8	SA3722001	M1 - 7	38	SA4647001	D2 - 9	18
S46903001	J - 19	30	SA3226001	E - 1	20	SA3744001	M1 - 6	38	SA4650001	F - 71	24
S47269001	C2 - 48	12	SA3227001	D1 - 42	16	SA3762001	M2 - 5	40	SA4666001	B - 30	8
S47270001	C2 - 8	12		E - 2	20	SA3765001	M2 - 2	40	SA4676101	A1 - 57	2
	C2 - 34	12	SA3228101	E - 3	20	SA3767001	M2 - 4	40	SA4677101	A1 - 55	2
	C2 - 41	12	SA3231001	E - 5	20	SA3768001	M2 - 6	40	SA4709001	C3 - 23	14
S47307001	E - 40	20	SA3238101	E - 21	20	SA3769001	M2 - 7	40	SA4720001	C3 - 18	14
S48140002	W1 - 29	58	SA3241001	E - 26	20	SA3770001	M2 - 8	40	SA4721001	C3 - 19	14
S48189000	F - 18	22	SA3244001	F - 1	22	SA3771001	M2 - 9	40	SA4741101	D2 - 1	18
S48664001	E - 48	20	SA3250001	G - 1	26	SA3788001	M1 - 16	38	SA4742001	D2 - 2	18
	Ap	70	SA3254001	G - 15	26	SA3789101	N - 4	42	SA4743001	D2 - 6	18
S49448001	Ga	72	SA3255001	G - 9	26		N - 6	42	SA4744001	D2 - 8	18
S49484000	M1 - 8	38	SA3256001	G - 19	26		N - 9	42	SA4745001	D2 - 13	18
S49982000	F - 17	22	SA3257101	G - 25	26	SA3794001	M2 - 10	40	SA4747001	D2 - 16	18
S51282101	Z - 33	68		Ap	71	SA3795001	M2 - 11	40	SA4748101	D2 - 18	18
S51283001	Z - 31	68	SA3258001	G - 26	26	SA3796001	M1 - 14	38	SA4753001	D2 - 29	18
S52163000	M1 - 15	38	SA3264001	A1 - 18	2	SA3797001	M1 - 3	38	SA4757101	D2 - 26	18
S53978000	P - 31	44	SA3274101	E - 39	20	SA3806001	M1 - 9	38	SA4759001	D1 - 1	16

CODE	REF.NO	Page	CODE	REF.NO	Page	CODE	REF.NO	Page	CODE	REF.NO	Page
SA4760001	D1 - 2	16	SA5201001	W5 - 1	66	SA6573001	P - 19	44	SA8538001	C2 - 37	12
SA4761001	D1 - 7	16	SA52010E1	W5 - 1	66	SA6576001	F - 40	22	SA8542001	C2 - 44	12
SA4762001	D1 - 8	16	SA5202001	W5 - 2	66	SA6578001	F - 15	22	SA8548101	A1 - 10	2
SA4763001	D1 - 3	16	SA52020E1	W5 - 2	66	SA6593001	F - 37	22	SA8549001	A1 - 37	2
SA4764001	D1 - 11	16	SA5203001	W5 - 5	66	SA6596001	J - 58	30	SA8550001	A1 - 38	2
SA4765001	D1 - 13	16	SA5204001	W5 - 8	66	SA6606001	Z - 41	68		A2 - 10	6
SA4766001	D1 - 16	16	SA5205001	W5 - 10	66	SA6607001	Z - 45	68	SA8551001	A1 - 40	2
SA4767001	D1 - 17	16	SA5206001	W5 - 11	66		Z - 46	68	SA8552001	A1 - 41	2
SA4768001	D1 - 18	16	SA5208001	K - 1	34	SA6609001	Z - 49	68	SA8553001	A1 - 43	2
SA4769101	D1 - 19	16	SA5213001	K - 25	34	SA6615001	Z - 50	68	SA8555001	A1 - 47	2
SA4770001	D1 - 21	16	SA5217001	K - 5	34	SA6628101	W5 - 3	66	SA8556001	A1 - 49	2
SA4771001	C3 - 9	14	SA5218001	K - 9	34	SA6629001	Z - 35	68	SA8557001	A1 - 51	2
	D1 - 27	16	SA5219001	K - 18	34	SA6674001	C2 - 13	12	SA8559001	A1 - 53	2
SA4772001	D1 - 22	16	SA5221001	Ap	70		C2 - 29	12	SA8560001	A1 - 54	2
SA4773001	D1 - 23	16		Ga	72	SA7155001	W1 - 24	58	SA8561001	A1 - 58	2
SA4777001	D1 - 26	16	SA5222101	Ap	70		W3 - 10	62	SA8562001	A1 - 59	2
SA4778001	D1 - 51	16		Ga	72		W3 - 19	62	SA8563001	A1 - 60	2
SA4779001	D1 - 32	16	SA5230001	B - 51	8	SA7163001	W3 - 4	62	SA8564001	A1 - 62	2
SA4780001	D1 - 35	16	SA5251001	A2 - 22	6	SA7164001	W3 - 5	62	SA8565101	B - 1	8
SA4781001	D1 - 33	16	SA5281101	P - 10	44	SA7166101	W1 - 5	58	SA8566001	C1 - 1	10
SA4782001	E - 4	20	SA5282001	P - 14	44	SA7167101	W1 - 8	58	SA8567001	C1 - 3	10
SA4785101	F - 2	22	SA5283001	P - 13	44	SA7171001	W1 - 6	58	SA8568001	C1 - 5	10
SA4786101	F - 5	22	SA5285001	P - 18	44	SA71710E1	W1 - 6	58	SA8569101	C1 - 7	10
SA4787001	F - 34	22	SA5286101	P - 21	44	SA7191001	Ga	72	SA8571001	C1 - 9	10
SA4788001	F - 36	22	SA5289001	P - 11	44	SA7197001	W1 - 9	58	SA8574001	C1 - 13	10
SA4789101	F - 20	22	SA5290001	W1 - 2	58	SA7199001	W1 - 21	58	SA8575001	C1 - 15	10
SA4796001	H - 20	28	SA5294001	F - 35	22	SA7293001	Q - 13	46	SA8576001	C1 - 16	10
SA4797101	H - 39	28	SA5300001	D1 - 55	16	SA74521E0	W1 - 7	58	SA8578001	C2 - 1	12
SA4798001	J - 3	30	SA5301001	D1 - 57	16	SA74700E1	W3 - 2	62	SA8579001	C2 - 2	12
SA4799001	J - 14	30	SA5331001	W2 - 15	60	SA7500001	W1 - 1	58		C2 - 18	12
SA4806001	K - 6	34	SA5339101	F - 19	22	SA75000E1	W1 - 1	58	SA8582001	C2 - 4	12
SA4811001	Ga	72	SA5415001	C3 - 49	14	SA7508001	W2 - 27	60		C2 - 20	12
SA4815101	Ap	71	SA5433001	Q - 22	46	SA7509101	W2 - 2	60	SA8583001	C2 - 6	12
SA4816001	W4 - 2	64	SA5436201	W2 - 1	60	SA7510001	W2 - 4	60		C2 - 22	12
SA4817001	W4 - 3	64	SA54362E1	W2 - 1	60	SA7511001	W2 - 9	60	SA8584001	C2 - 7	12
SA4818001	W4 - 4	64	SA5559101	W3 - 14	62	SA7512001	W2 - 14	60	SA8585001	C2 - 9	12
SA4819001	W4 - 6	64	SA5575101	W3 - 1	62	SA7513001	W2 - 3	60	SA8586001	C2 - 11	12
SA4826501	D2 - 4	18	SA55751E1	W3 - 1	62	SA75390E1	W1 - 2	58	SA8587001	C2 - 14	12
SA4829001	W2 - 17	60	SA5730101	Q - 9	46	SA75410E1	W2 - 15	60		C2 - 27	12
SA4834101	R - 1	48	SA5731001	Q - 10	46	SA7620101	W3 - 9	62	SA8590001	C1 - 18	10
SA4836001	R - 7	48	SA5732101	Q - 11	46	SA7794001	M2 - 12	40		C1 - 20	10
SA4837101	R - 5	48	SA6038001	T - 1	52	SA7944001	J - 63	32	SA8592001	C2 - 17	12
SA4841101	R - 6	48	SA6087001	F - 9	22	SA8057001	K - 12	34	SA8593001	C2 - 23	12
SA4847001	A2 - 25	6	SA6108001	B - 36	8	SA8197101	E - 52	20	SA8595001	C2 - 24	12
SA4853001	D1 - 39	16	SA6182001	B - 19	8		Ap	70	SA8596001	C2 - 25	12
SA4855001	L - 1	36	SA6190001	W2 - 5	60	SA8248001	U - 2	54	SA8597001	C2 - 31	12
SA4932001	W2 - 12	60	SA6193201	W2 - 10	60	SA8249001	U - 3	54		C3 - 3	14
SA5072001	F - 14	22	SA6207001	A1 - 19	2	SA8250001	U - 10	54		C3 - 34	14
SA5133001	W2 - 16	60	SA6210001	D2 - 20	18	SA8251001	U - 11	54	SA8598001	C2 - 42	12
SA5134001	W5 - 12	66	SA6272001	A1 - 16	2	SA8376001	M1 - 4	38	SA8599001	C2 - 36	12
SA5135101	J - 4	30	SA6273101	J - 68	32	SA8378001	M1 - 5	38		C2 - 43	12
SA5157101	J - 57	30	SA6284001	W2 - 24	60	SA8383001	M2 - 1	40	SA8601001	C2 - 46	12
SA5158101	B - 48	8	SA6364001	M1 - 1	38	SA8384001	M2 - 3	40	SA8602001	C2 - 32	12
SA5164001	V - 1	56	SA6366001	Q - 34	46	SA8387001	N - 2	42	SA8604001	C2 - 35	12
SA5165001	V - 2	56	SA6389001	L - 9	36	SA8521001	Q - 5	46	SA8607001	C2 - 39	12
SA5166001	V - 3	56	SA6391001	G - 5	26	SA8522001	Q - 7	46	SA8608001	C1 - 22	10
SA5167001	V - 7	56	SA6397001	J - 62	30	SA8523001	Q - 8	46	SA8609001	C1 - 24	10
SA5170001	V - 4	56	SA6398001	J - 62	32	SA8524001	Q - 12	46	SA8611001	C1 - 25	10
SA5172001	V - 5	56	SA6495001	W5 - 16	66	SA8527001	Q - 19	46	SA8612001	C1 - 27	10
SA5191001	P - 24	44	SA64950E1	W5 - 16	66	SA8528001	Q - 20	46	SA8615001	C1 - 28	10
SA5193101	W4 - 1	64	SA6572001	D1 - 44	16	SA8529001	L - 19	36	SA8617001	C1 - 30	10
SA51931E1	W4 - 1	64		F - 43	22	SA8532001	Q - 25	46	SA8619001	C1 - 31	10
SA5194001	W4 - 7	64		F - 44	22	SA8533001	Q - 26	46	SA8622001	C1 - 32	10

索引 / Index

CODE	REF.NO	Page	CODE	REF.NO	Page	CODE	REF.NO	Page	CODE	REF.NO	Page
SA8623001	C1 - 33	10	SA8707001	E - 31	20						
SA8624001	C1 - 34	10	SA8708001	F - 53	22						
SA8625001	C1 - 35	10	SA8709001	E - 33	20						
SA8626001	C1 - 38	10	SA8710001	E - 34	20						
SA8628001	C3 - 1	14	SA8711001	E - 35	20						
SA8629001	C3 - 2	14	SA8712101	E - 36	20						
SA8631001	C3 - 4	14	SA8713001	E - 37	20						
SA8632001	C3 - 5	14	SA8714001	F - 6	22						
SA8633001	C3 - 6	14	SA8717001	F - 25	22						
SA8634001	C3 - 7	14	SA8718001	F - 26	22						
SA8635001	C3 - 13	14	SA8720001	F - 38	22						
SA8636001	C3 - 15	14	SA8721001	F - 39	22						
SA8638001	C3 - 21	14	SA8722001	F - 45	22						
SA8640001	C3 - 27	14	SA8723001	F - 46	22						
SA8641001	C3 - 28	14	SA8724001	F - 47	22						
SA8642001	C3 - 31	14	SA8725001	F - 48	22						
SA8643001	C3 - 32	14	SA8726001	F - 49	22						
SA8644001	C3 - 33	14	SA8727001	F - 50	22						
SA8645001	C3 - 38	14	SA8728001	F - 51	22						
SA8646001	C3 - 40	14	SA8729001	F - 52	22						
SA8648001	C3 - 43	14	SA8732001	F - 55	22						
SA8650001	H - 1	28	SA8733001	F - 58	22						
SA8652001	J - 37	30	SA8734001	F - 61	22						
SA8654001	J - 38	30	SA8735001	F - 62	22						
SA8655001	J - 47	30	SA8736001	F - 65	24						
SA8656001	J - 52	30	SA8783001	F - 12	22						
SA8657001	J - 53	30	SA8784001	F - 13	22						
SA8658101	J - 55	30	SA8785001	F - 54	22						
SA8659001	P - 1	44	SA8786001	F - 63	22						
SA8659002	P - 2	44	SA8816001	A1 - 45	2						
SA8660001	P - 3	44	SA8818001	C3 - 41	14						
SA8660002	P - 4	44	SA8819001	C1 - 11	10						
SA8661001	P - 5	44	SA8820001	C3 - 29	14						
SA8664001	R - 14	48	SA8824001	N - 1	42						
SA8665001	A2 - 3	6	SA8825001	N - 3	42						
SA8667001	A2 - 5	6	SA8826001	N - 7	42						
SA8668001	A2 - 1	6	SA8827001	N - 5	42						
SA8669001	A2 - 6	6	SA8855001	Z - 62	68						
SA8670001	A1 - 31	2	SA8859001	C3 - 45	14						
SA8671001	A2 - 12	6	SA8860001	C3 - 46	14						
SA8672001	A1 - 63	2	SA8869001	C3 - 48	14						
SA8673001	A2 - 16	6	SA8870001	C3 - 50	14						
SA8674001	A2 - 17	6	SA8871001	C3 - 47	14						
SA8675001	A2 - 31	6	SA8879001	A1 - 64	4						
SA8679001	A1 - 29	2	SA8880001	A1 - 34	2						
SA8680001	A1 - 32	2	SA8881001	Q - 33	46						
	A1 - 35	2	SA8904001	C3 - 44	14						
SA8683001	D1 - 38	16	SA8909001	C3 - 26	14						
SA8684001	D1 - 40	16	SA8912001	D1 - 45	16						
SA8688001	D1 - 43	16	SA9004001	E - 32	20						
SA8689001	D1 - 47	16	SA9105001	Q - 18	46						
SA8690001	D1 - 63	16	XD1115051	V - 6	56						
SA8691001	G - 23	26									
SA8692001	U - 1	54									
SA8694001	C2 - 49	12									
SA8695001	E - 7	20									
SA8696001	E - 10	20									
SA8697001	E - 11	20									
SA8698001	E - 13	20									
SA8701001	E - 15	20									
SA8702001	E - 17	20									
SA8703001	E - 19	20									
SA8705001	E - 23	20									

MEMO

brother[®]



パーツブック
PARTS BOOK

ブラザー工業株式会社 <http://www.brother.co.jp/>

BROTHER INDUSTRIES, LTD. <http://www.brother.com/>