

mitsubishi

三菱工業用ミシン部品カタログ

Industrial Sewing Machine Parts Catalog

Model PLK-E2010R

	目次	CONTENTS	Page
A	本体構成	Construction	1
B	本体関係 (I)	Arm bed & it's accessories (I)	2
C	本体関係 (II)	Arm bed & it's accessories (II)	4
D	本体関係 (III)	Arm bed & it's accessories (III)	6
E	上軸・堅軸・天ビン・針棒機構	Arm shaft vertical shaft and thread take-up lever needle bar mechanism ·	8
F	中押え機構	Presser bar lifting mechanism	10
G	下軸・カマ機構	Hook shaft hook mechanism	12
H	糸切り機構	Thread trimming mechanism	14
J	X-Y テーブル機構	X-Y table mechanism	16
K	外押え機構 (I)	Work holder mechanism (I)	18
L	外押え機構 (II)	Work holder mechanism (II)	20
M	ワイパー機構	Wiper mechanism	22
N	給油機構	Oil lubrication mechanism	24
P	配線・配管関係	Cable component & Pneumatic control unit	26
Q	テーブル関係	Table & Stand	28
R	付属品 (I)	Accessories (I)	30
S	付属品 (II)	Accessories (II)	32
T	オプションパーツ	Option parts	34
	索引	Index	36

ミシン用部品コードの採番基準 MITSUBISHI SPARE PARTS No. Designation system

1. 部品コードについて CONCERNING PARTS CODE.

部品を注文される場合は、部品コードをお知らせください。
Please inform the part number, when these parts are ordered.

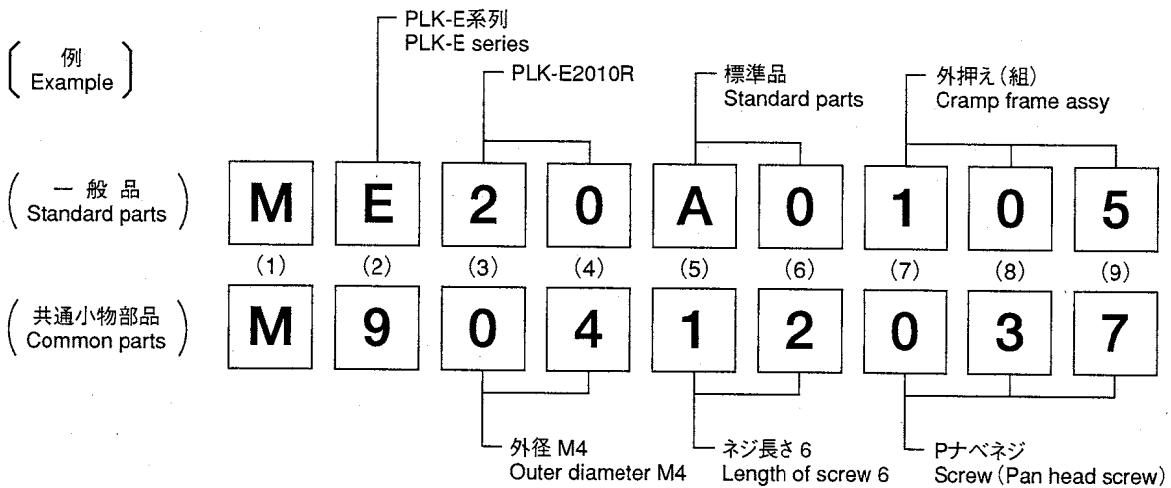
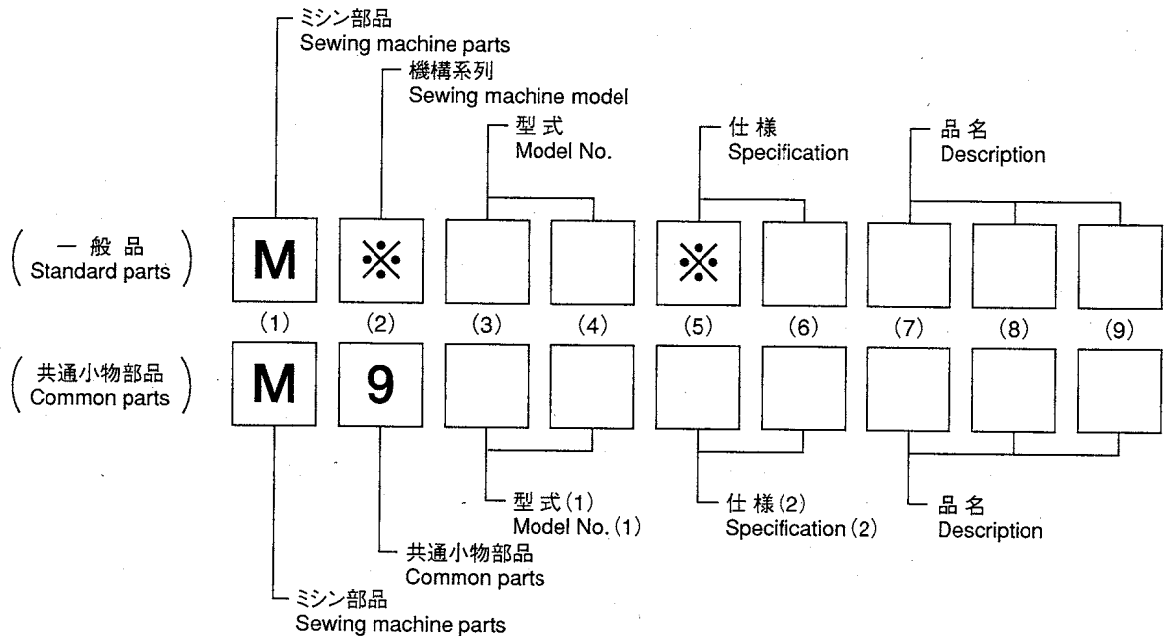

2. 変更マークについて CONCERNING MODIFICATION MARK.

変更マーク欄に*記号のある部品は、形状、寸法などの変更履歴がありますので、ご注文の際にはご使用の製品の製造番号と合わせてご覧ください。

The parts marked with * in the modification column has been changed the shape or size etc. So when these modified parts are ordered please inform the serial number of the sewing machine.

注：一般品についての機種型名は、その部品が最初に使用された機種型名を示します。従って長期にわたる場合は、機種の変更が行われるため、当初の機種以外の機種で使用されている場合があります。

Sewing machine Models, of Standard Parts are indicated model of these parts are registered firstly. Parts are used for not only the indicated model, but also another models, in reason of New development, improvement after.

㊦ 全体構成
CONSTRUCTION

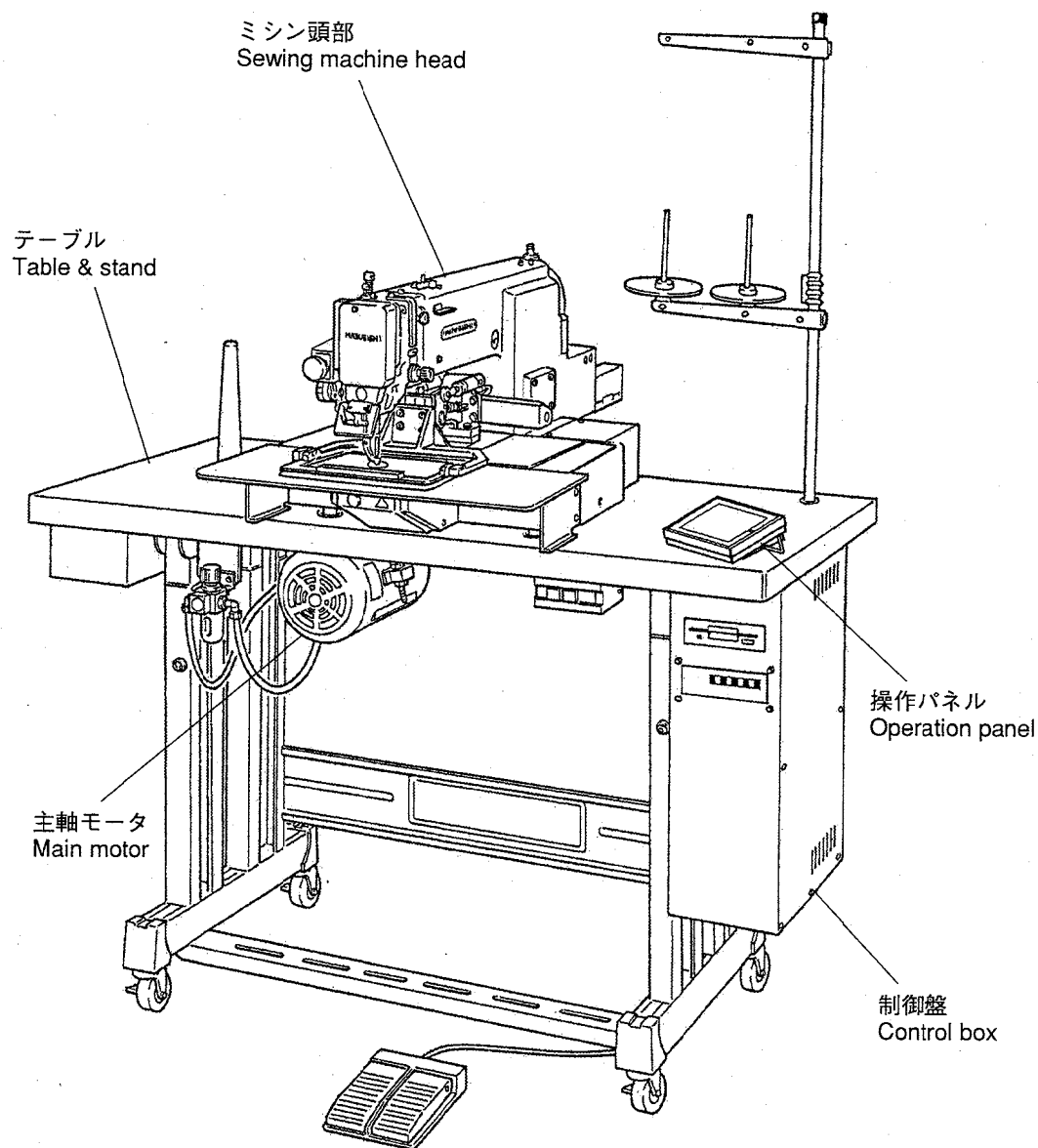

注1:モータ部分は三菱リミサーボX部品カタログを参照ください。

注2:Fig.No.の採番していない部品は単体で支給することはできません。Setにて支給いたします。

Remarks 1: Concerning about the motor parts please refer to the parts catalog of MITSUBISHI LIMISERBO X.

Remarks 2: The parts which Fig.No. are not marked are not available individually. It can be supplied with the whole component.

B 本体関係 (I)
 ARM BED & IT'S ACCESSORIES (I)

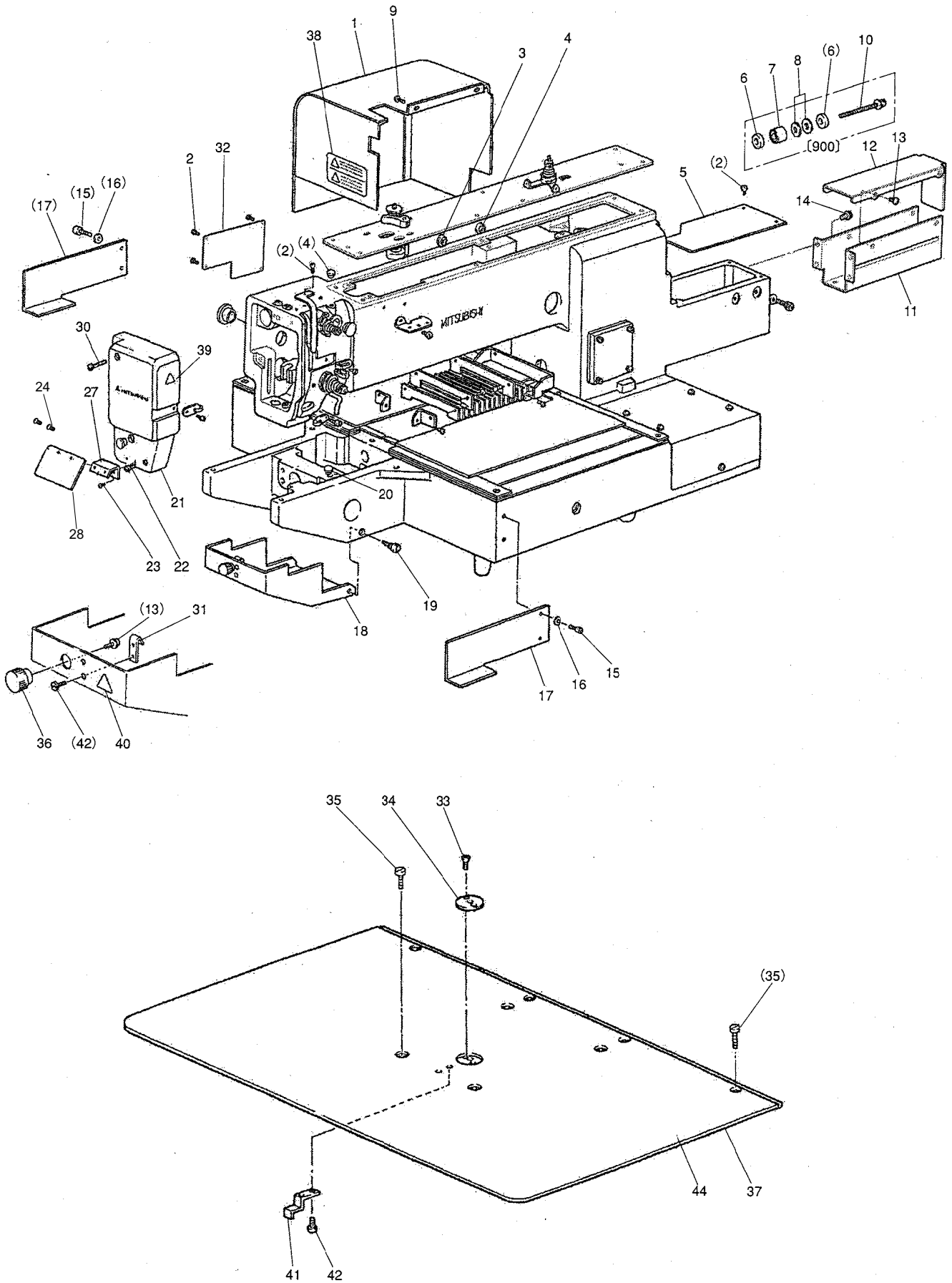

[B]本体関係(I)

ARM BED & IT'S ACCESSORIES(I)

Fig no.	変更 Mod.	部品コード Parts no.	品 名	Description	数量 Amt. Req.
B 1		MB61E0849	モータカバークミタテ	Motor cover	1
B 2		M91054004	SW-PWフライナネジ M4X8	Screw M4X8	8
B 3		M90883080	ゴムセン φ8.8	Rubber plug φ8.8	1
B 4		M91304080	セン φ13	Rubber plug φ13	3
B 5		MB61A0742	フタ	Cover	1
B 6		M90823050	ミカキサガネ 8	Washer 8	3
B 7		MB60A0750	ブッシュ	Holder	1
B 8		MS10A1456	ベアリング	Bearing	2
B 9	A	M91071004	SW-MWフライナネジ M4X8	Screw M4X8	3
B 10	A	M91803022	ロックアナツキボルト M8X40	Bolt M8X40	1
B 11		ME20A0408	Yケンシュツダイクミタテ	Detector bracket (Y) assy	1
B 12		ME20A0339	Yケンシュツキカバー	Detector cover (Y)	1
B 13		M91058004	SW-PWフライナネジ M4X6	Screw M4X6	5
B 14	A	M91056004	SW-PWフライナネジ M4X10	Screw M4X10	4
B 15		M96002017	セフティソケット M6X12	Bolt M6X12	4
B 16		M90631050	ミカキサガネ 6	Washer 6	4
B 17		MB61A0601	トリツケイタ	Holder	2
B 18		MB61A1339	シリンダーカバー	Cylinder cover	1
B 19		M94001030	トクシュネジ	Screw	2
B 20	A	M90573080	セン φ5.7	Rubber plug φ5.7	1
B 21		ME20A0830	メンイタ	Face plate	1
B 22	A	M91055004	SW-PWフライナネジ M4X22	Screw M4X22	1
B 23		M91110002	ヒラネジ 11/64(40)X8	Screw 11/64(40)X8	2
B 24		M90806002	ヒラネジ 1/8(44)X6	Screw 1/8(44)X6	2
B 27		MB61A1601	アイガードトリツケイタ	Eye guard adapter	1
B 28		MS01A0160	アイガード	Eye guard	1
B 30	A	M91066004	SW-PWフライナネジ M4X25	Screw M4X25	1
B 31		MS01A0361	カケガネ	Latch	1
B 32		ME10A0742	フタ	Cover	1
B 33		M90605010	サラネジ 2/32(56)X2.8	Screw 2/32(56)X2.8	2
B 34		MS02A1101	ハリアナイタ	Needle plate	1
B 35		M90990002	ヒラネジ M4X8	Screw M4X8	4
B 36		MB61A0650	ナールトノブ	Knurled knobs	1
B 37		MB61A0470	スベリイタ	Slide plate	1
B 38		MB61A0459	ケイコクシール	Warnig seal	1
B 39		MB61A1459	ケイコクシール	Warnig seal	1
B 40		MB61A2459	ケイコクシール	Warnig seal	1
B 41		MS10A0192	イタハネ	Leaf spring	1
B 42		M90906003	マルヒラネジ 9/64(40)X3.2	Screw 9/64(40)X3.2	4
B 44		MB61A0797	ホコフィルム	Film sheet	1
B 900	A	ME20E0750	ブッシュクミタテ	Idler pulley	1

□ 本体関係 (Ⅱ)
 ARM BED & IT'S ACCESSORIES (Ⅱ)

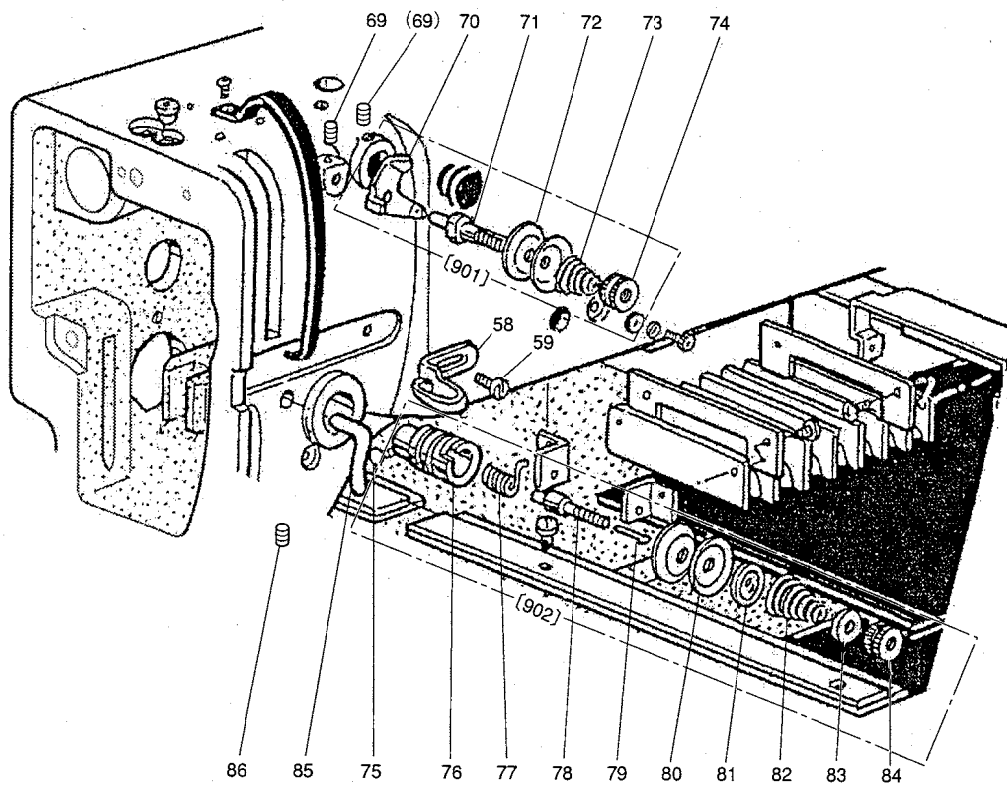
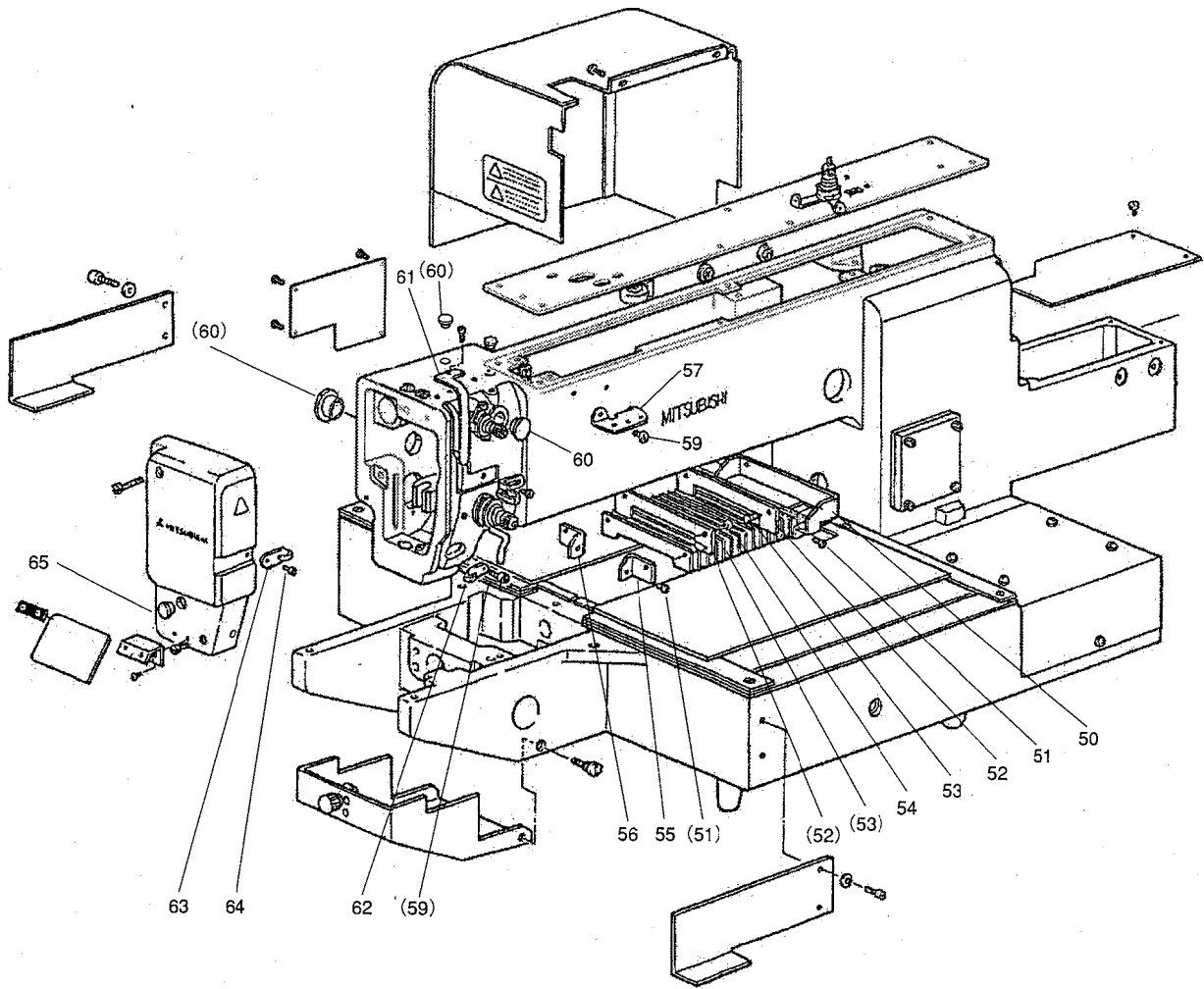

[C]本体関係(Ⅱ)
ARM BED & IT'S ACCESSORIES(Ⅱ)

Fig no.	変更 Mod.	部品コード Parts no.	部品名	Description	数量 Amt. Req.
C 50		MS10A9601	ジャバラトリツケイタ	Shutter adapter	1
C 51		M91058004	SW-PWフライナヘネジ M4X6	Screw M4X6	4
C 52		MS10A0257	オサエイタ	Shutter holder	2
C 53		M90859004	SW-PWフライナヘネジ M3X6	Screw M3X6	4
C 54		MB61A0458	ジャバラ	Shutter	1
C 55		MB61A2601	ジャバラトリツケイタ(ミキ)	Shutter adapter (R)	1
C 56		MB61A3601	ジャバラトリツケイタ(ヒタリ)	Shutter adapter (L)	1
C 57		MF36A1180	イトアンナイ	Thread guide	1
C 58		MG43A0181	イトアンナイ	Thread guide	1
C 59	A	M91011004	フライナヘネジ M4X6	Screw M4X6	3
C 60		M91910080	ゴムセン φ19	Rubber plug φ19	3
C 61		MF03A0584	テンピンカバー	Thread take-up lever guard	1
C 62		MF10A0181	イトアンナイ	Thread guide	1
C 63		MG43A1181	イトアンナイ	Thread guide	1
C 64		M90909003	マルヒラネジ 9/64(40)X6	Screw 9/64(40)X6	2
C 65		M91182080	ゴムセン φ11.8	Rubber plug φ11.8	1
C 69	A	M91053020	ロックアナツキトメネジ M4X6	Screw M4X6	2
C 70		MF00A0181	イトアンナイ	Thread guide	1
C 71		MF90A0553	チョウシボウ	Thread tension stud	1
C 72		MF10A1555	チョウシザラ	Thread tension discs	2
C 73		MF36A0245	エンスイハネ	Thread tension spring	1
C 74		M91101046	ツマミナット	Thumb nut	1
C 75		M90901002	ヒラネジ 9/64(40)X4	Screw 9/64(40)X4	1
C 76		MF10A0709	ブッシュ	Thread tension regulator bushing	1
C 77		MF10A0187	イトトリハネ	Thread take-up spring	1
C 78		MF10A0553	チョウシボウ	Thread tension stud	1
C 79		M90204060	ピン	Thread tension releasing pin	1
C 80		MF10A0555	チョウシザラ	Thread tension discs	2
C 81		MM11A0556	チョウシザラオサエ	Thread tension releasing disc	1
C 82		MN52A1245	エンスイハネ	Tension spring	1
C 83		MT60A0802	マワリトメ	Thumb nut revolution stopper	1
C 84		M91610046	ツマミネジ	Thumb nut	1
C 85		MF70A1180	イトアンナイ	Thread guide	1
C 86	A	M95004020	ロックアナツキトメネジ M5X8	Screw M5X8	1
C 901		MF00E0550	イトチョウセツキクミタテ	Pre-tension complete	1
C 902		MA16E0210	チョウセツキクミタテ	Thread tension regulator complete	1

㊦ 本体関係 (Ⅲ)
 ARM BED & IT'S ACCESSORIES (Ⅲ)

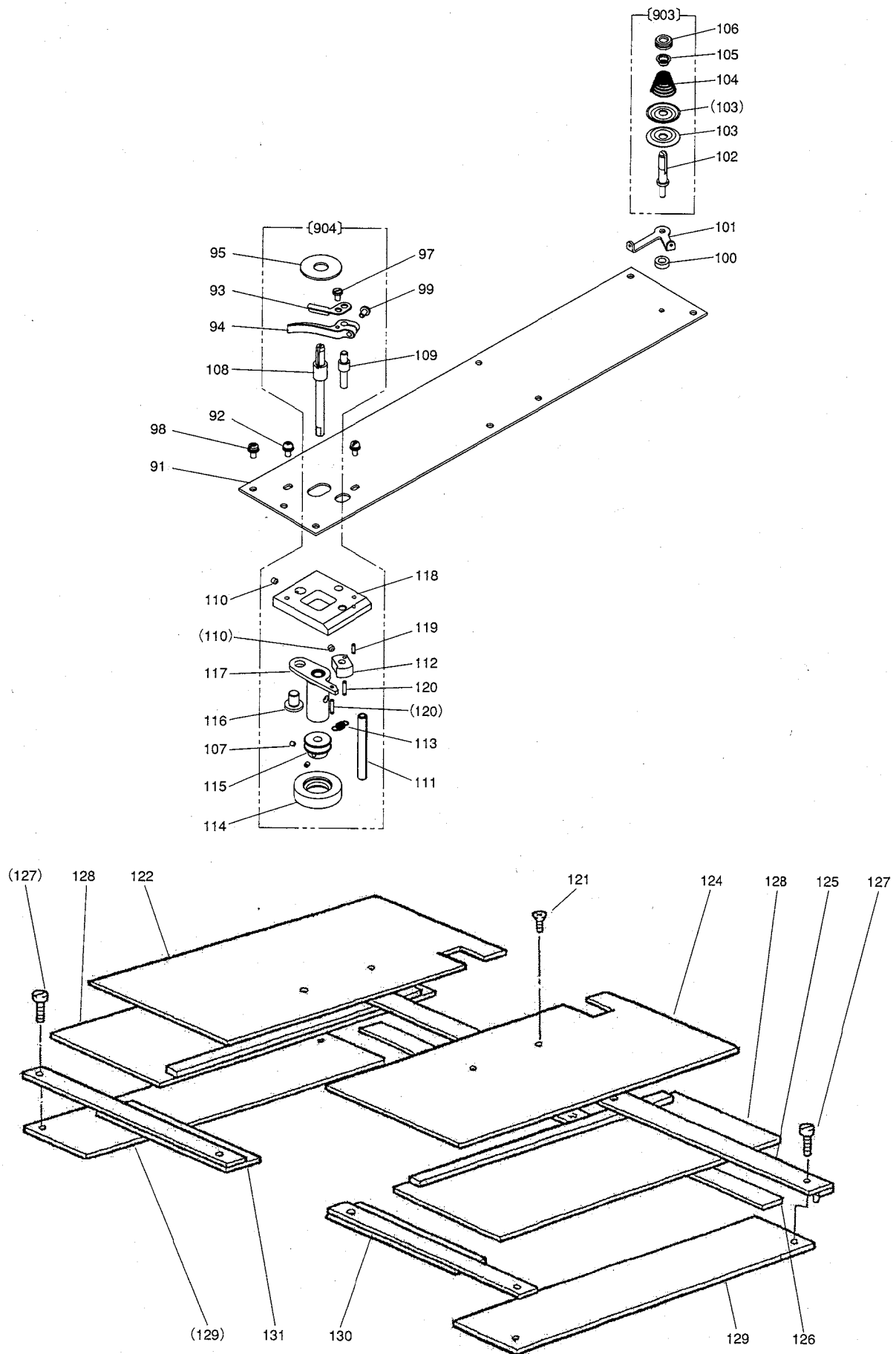

[D]本体関係(Ⅲ)
ARM BED & IT'S ACCESSORIES(Ⅲ)

Fig no.	変更 Mod.	部品コード Parts no.	部品名	Description	数量 Amt. Req.
D 91		ME20A0600	トップカバー	Top cover	1
D 92	A	M91054004	SW-PW7プラスナベネジ M4X8	Screw M4X8	6
D 93	A	ME25A0551	チョウセツイタ	Adjuster plate	1
D 94	A	ME25A0950	レバー	Lever	1
D 95		MA20A0476	スペーサ	Spacer	1
D 97	A	M90920002	ヒラネジ 9/64(40)X6.5	Screw 9/64(40)X6.5	1
D 98	A	M91013004	SW-MW7プラスナベネジ M4X10	Screw M4X10	2
D 99	A	M90939002	ヒラネジ 9/64(40)X11	Screw 9/64(40)X11	1
D 100		MG75A1476	スペーサ	Spacer	1
D 101		MS14A1180	イトアンナイ	Thread guide	1
D 102		MS14A0553	チョウシホウ	Thread tension stud	1
D 103		MF10A0555	チョウシサラ	Thread tension discs	2
D 104		MM11A0245	エンスイバネ	Thread tension spring	1
D 105		MM11A0702	バネアンナイ	Spring guide	1
D 106		M91602046	ツミナット	Thumb nut	1
D 107	A	M91057020	トメネジ M3X4	Screw M3X4	2
D 108		MA16A0530	ダンツクシク	Driven shaft	1
D 109		ME25A0530	ダンツクシク	Shaft	1
D 110		M91055020	ロックアアナツキトメネジ M4X4	Screw M4X4	2
D 111		M90602064	スプリングピン φ6X40	Spring pin φ6X40	1
D 112		MS14A0350	カム	Cam	1
D 113		MS14A0572	ツルマキバネ	Helical spring	1
D 114		MS03A0417	ゴムワ	Tire	1
D 115		MA20A0194	イトマキケルマ	Wheel	1
D 116		M99006063	ツバツクシク	Pin	1
D 117		MB61E0750	ブッシュクミタテ	Lever	1
D 118		MB60A1601	トリツケダイ	Bracket	1
D 119	A	M91004067	ミゾツキピン BXガタ φ2.5X8	Pin BXガタ φ2.5X8	1
D 120	A	M91005067	ミゾツキピン BXガタ φ2.5X12	Pin BXガタ φ2.5X12	2
D 121		M90858004	プラマイサラネジ M3X6	Screw M3X6	4
D 122		MB61E0339	Xカバーイタクミタテ (ヒタリ)	X-cover plate assy (L)	1
D 124		MB61E1339	Xカバーイタクミタテ (ミキ)	X-cover plate assy (R)	1
D 125		MB61E0359	カバーガイドクミタテ (ウシロ)	Cover guide (rear)	1
D 126		MB61A0476	スペーサ	Spacer	1
D 127		M90990002	ヒラネジ M4X8	Screw M4X8	8
D 128		MB61E3339	Xイトウカバークミタテ	X-movable cover assy	2
D 129		MB61A3339	X-Yカバー	X-Y cover	2
D 130		MB61E0476	スペーサクミタテ (ミキ)	Spacer assy (R)	1
D 131		MB61E1476	スペーサクミタテ (ヒタリ)	Spacer assy (L)	1
D 903		MS14E0180	チョウセツクミタテ	Thread tension regulator complete	1
D 904		ME20E0190	イトマキソウチクミタテ	Bobbin winder complete	1

上軸・堅軸・天ビン・針棒機構

ARM SHAFT VERTICAL SHAFT AND THREAD TAKE-UP LEVER NEEDLE BAR MECHANISM

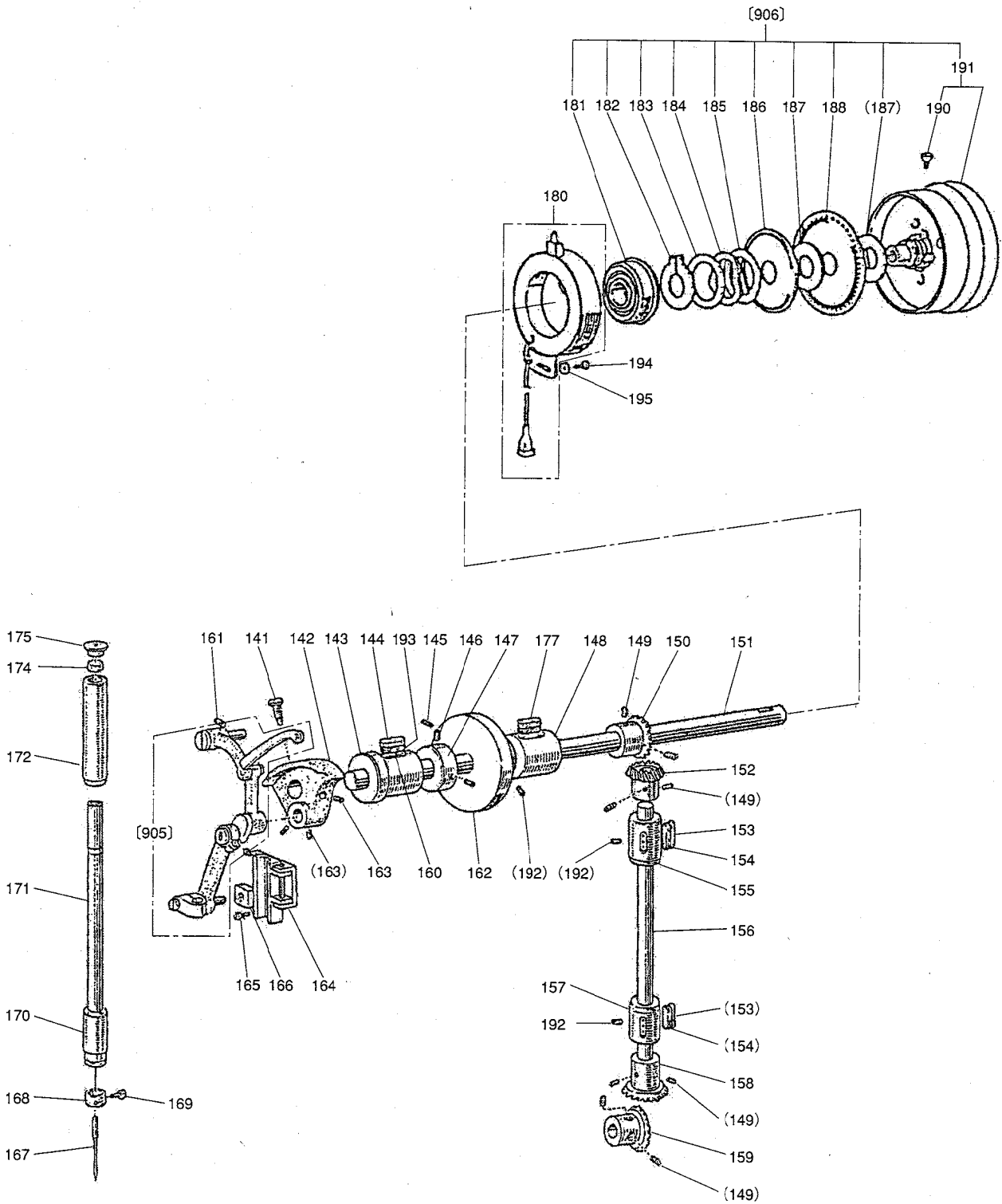

[E]上軸・堅軸・天ビン・針棒機構

ARM SHAFT VERTICAL SHAFT AND THREAD TAKE-UP LEVER NEEDLE BAR MECHANISM

Fig no.	変更 Mod.	部品コード Parts no.	品名	Description	数量 Amt. Req.
E 141		M91802006	ホウサキヒラネジ 9/32(28)X14	Screw 9/32(28)X14	1
E 142		MF60A1383	クランク	Crank	1
E 143		MS10A0232	ウワジクメタル (ヒタリ)	Arm shaft bushing (left)	1
E 144	A	MG50A0740	フェルト	Felt	1
E 145		M91053020	アナツキトメネジ M4X6	Screw M4X6	2
E 146		M91602001	トメネジ 1/4(40)X4	Screw 1/4(40)X4	2
E 147		MF80A0352	カラー	Collar	1
E 148		MB61E0234	ウワジクメタル (ナカ)	Arm shaft bushing (middle)	1
E 149		M91610001	トメネジ 1/4(40)X7	Screw 1/4(40)X7	8
E 150		MF40A0331	ウワジクカサハグルマ	Bevel gear for arm shaft	1
E 151		MB61A0230	ウワジク	Arm shaft	1
E 152		MF40A0333	タテジクカサハグルマ (ウエ)	Bevel gear for vertical shaft (U)	1
E 153		MF60A0740	フェルト	Felt	2
E 154		MS10A0740	フェルト	Felt	2
E 155		MB61E0521	タテジクメタルウエクミタテ	Vertical shaft bushing (upper)	1
E 156		MA25A0520	タテジク	Vertical shaft	1
E 157		MS10A0522	タテジクメタル (シタ)	Vertical shaft bushing (lower)	1
E 158		MF10A0334	タテジクカサハグルマ (シタ)	Bevel gear for vertical shaft (L)	1
E 159		MF10A0332	シタジクカサハグルマ	Bevel gear for hook shaft	1
E 160		MS10A1740	フェルト	Felt	1
E 161		M91221001	クボミサキトメネジ M5X12	Screw M5X12	1
E 162		MS14A0682	プーリ	Pulley	1
E 163		M91606001	トメネジ 1/4(40)X7	Screw 1/4(40)X7	3
E 164		MG44E0662	ハリクカイトクミタテ	Needle bar connecting link guide	1
E 165		M90990002	ヒラネジ M4X8	Screw M4X8	1
E 166		MF10A0325	カクコ	Square block	1
E 167		MS02A0128	ミシンハリ DPX17#18	Needle DPX17#18	1
E 168		MG42A0181	イトアンナイ	Thread guide	1
E 169		M90815002	ヒラネジ 1/8(44)X4.5	Screw 1/8(44)X4.5	1
E 170		MF10A0664	ハリホウメタルシタ	Needle bar bushing (lower)	1
E 171		MA25A0660	ハリホウ	Needle bar	1
E 172		MS10A0663	ハリホウメタルウエ	Needle bar bushing (upper)	1
E 174		MF10A2740	フェルト	Felt	1
E 175		MF60A0742	フタ	Cap for needle bar bushing	1
E 177		MB61A0740	フェルト	Felt	1
E 180		ME20A0406	ケンシュツキクミタテ	Detector complete	1
E 181		MN10A1456	ジクウケ	Ball bearing	1
E 182		M90330065	C ガ外メ 30	Retaining ring C-type 30	1
E 183		M93001050	サガネ	Washer	1
E 184		MF01A0259	ハンジャハンオサエスプリング	Supporter spring	1
E 185		MF01A1476	スパーサ B	Spacer B	1
E 186		MN72A1694	ハンジャハン F20 (ウエ)	Speed command disk F20 (up)	1
E 187		MF01A0476	スパーサ A	Spacer A	2
E 188		MB60A0694	ハンジャハン K10 (シタ)	Speed command disk K10 (down)	1
E 190		M91520002	ヒラネジ 15/64(28)X12	Screw 15/64(28)X12	2
E 191		MB60E0682	プーリクミタテ	Pulley complete	1
E 192	A	M95002020	ロツカクアナツキトメネジ M5X6	Screw M5X6	3
E 193	A	MV88A0740	フェルト	Felt	1
E 194	A	M91056004	SW-PWフライナナネジ M4X10	Screw M4X10	1
E 195	A	M90421050	サガネ 4	Washer 4	1
E 905		MS05E0580	テンビンハリクミタテ	Thread take-up lever complete	1
E 906		MB60E1682	プーリクミタテ	Pulley complete	1

F 中押え機構
 PRESSER BAR LIFTING MECHANISM

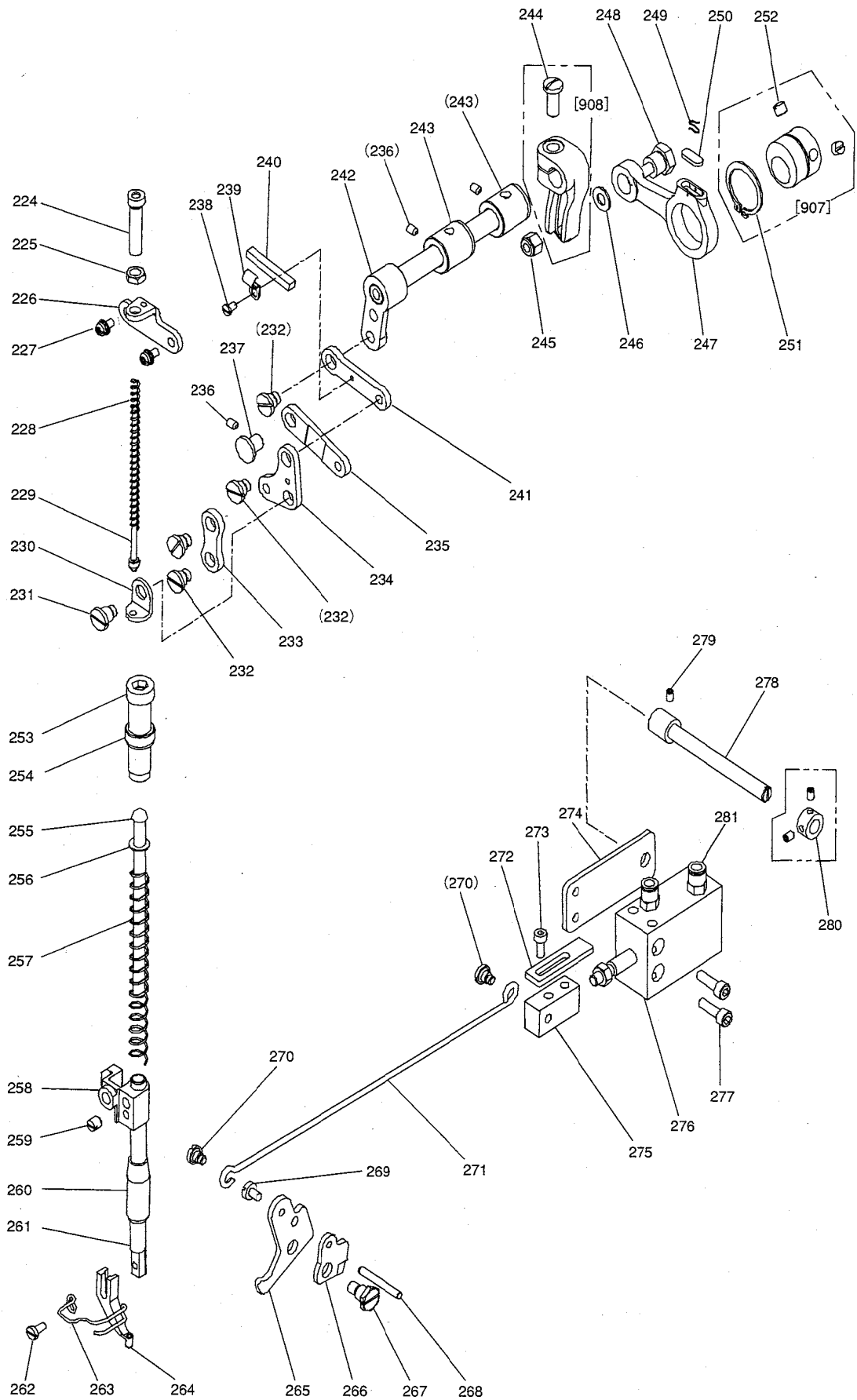

[F] 中押え機構

PRESSER BAR LIFTING MECHANISM

Fig no.	変更 Mod.	部品コード Parts no.	品名	Description	数量 Amt. Req.
F 224		M91801035	ツマミネジ 9/32(28)X35	Thumb screw 9/32(28)X35	1
F 225		M91802045	ナット 9/32(28)	Nut 9/32(28)	1
F 226		ME10A0261	オサエチヨウセツダイ	Bracket	1
F 227	A	M91056004	SW-PWプライナヘネジ M4X10	Screw M4X10	2
F 228		ME10A0572	ツルマキハネ	Spring	1
F 229		MS03A6154	アンナイガネ	Spring guide bar	1
F 230		ME20A0426	オサエイタササエ	Supporter	1
F 231		M91689015	ヒラネジダンツキ 1/4(40)	Screw 1/4(40)	1
F 232		M91688015	ヒラネジダンツキ 1/4(40)	Screw 1/4(40)	4
F 233		ME10A6910	リンク	Link	1
F 234		ME10A0763	ベルクランク	Bell crank	1
F 235		ME10A7910	リンク	Link	1
F 236	A	M91058020	ロッカクアナツキトメネジ M4X10	Screw M4X10	3
F 237		M99006063	ツバツクシク	Pin	1
F 238		M90909003	マルヒラネジ 9/64(40)X6	Screw 9/64(40)X6	1
F 239		MN70A1780	ホルダ	Holder	1
F 240		MG30A0740	フェルト	Felt	1
F 241		ME10A1956	レンセツカン	Link	1
F 242		MS02E0460	ウデクミタテ	Arm shaft assy	1
F 243		MG30A0833	メタル	Bushing	2
F 244		M91603003	マルヒラネジ 1/4(40)X16	Screw 1/4(40)X16	1
F 245		M91572045	Uナット 6X0.75	U-nut 6X0.75	1
F 246		M90631050	サガネ 6	Washer 6	1
F 247		ME10A0956	レンセツカン	Crank rod	1
F 248		M91551015	ホルトダンツキ M6	Bolt M6	1
F 249		MF60A0700	センサイクハネ	Holder	1
F 250		MG30B0740	フェルト	Felt	1
F 251		M90325065	Cガ外メ 25	C-type retaining ring 25	1
F 252		M91606001	トメネジ 1/4(40)X6	Screw 1/4(40)X6	2
F 253		M93220035	ツマミネジ 1/2(28)X43	Thumb screw 1/2(28)X43	1
F 254		M93202047	ナット 1/2(28)	Nut 1/2(28)	1
F 255		MF20A0703	アンナイホウ	Presser bar guide	1
F 256		M90632050	コサガネ 6	Washer 6	1
F 257		MS02A0259	ツルマキハネ	Spring	1
F 258		MG75A0265	オサエホウダキ	Presser bar holder	1
F 259		M91506001	トメネジ 15/64(28)X6	Screw 15/64(28)X6	1
F 260		MF10A0267	オサエホウメタル	Bushing	1
F 261		MS03A0262	オサエホウ	Presser bar	1
F 262		M90922002	ヒラネジ 9/64(40)X8	Screw 9/64(40)X8	1
F 263		MB62A0626	ニートルガード	Needle guard	1
F 264		MV30A0256	オサエ φ3	Presser foot φ3	1
F 265		ME10A1252	オサエアケレバ	Lifting lever	1
F 266		MF70A0350	イトルカム	Plate cam	1
F 267		M91504031	ホルトダンツキ 15/64(28)	Bolt 15/64(28)	1
F 268		M90423060	イトルメピン	Pin	1
F 269		M91131002	ヒラネジ 11/64(40)X6.5	Screw 11/64(40)X6.5	1
F 270		M91219015	ヒラネジダンツキ 3/16(28)	Screw 3/16(28)	2
F 271		ME20A0738	ヒキホウ	Link	1
F 272		ME20A0477	ストッパ	Stopper	1
F 273		M95003017	セフティソケット M5X8	Bolt M5X8	2
F 274		ME25A0601	トリツケイタ	Adapter	1
F 275		ME25A0571	ジョイント	Joint	1
F 276		ME25A0434	エアシリンダ	Air cylinder	1
F 277		M95006017	セフティソケット M5X22	Bolt M5X22	2
F 278		M95004020	ロッカクアナツキトメネジ M5X8	Screw M5X8	1
F 279		ME20A0530	ダンツクシク	Shaft	1
F 280	A	ME20A0352	カラー	Collar	1
F 281	A	ME40A0571	ワシタツツキテ	Connector	2
F 907		MG30A0760	ヘンシンリンクミタテ	Eccentric cam assy	1
F 908		MS02A0463	ウデ (ミキ)	Arm (right)	1

G 下軸・カム機構
HOOK SHAFT AND HOOK MECHANISM

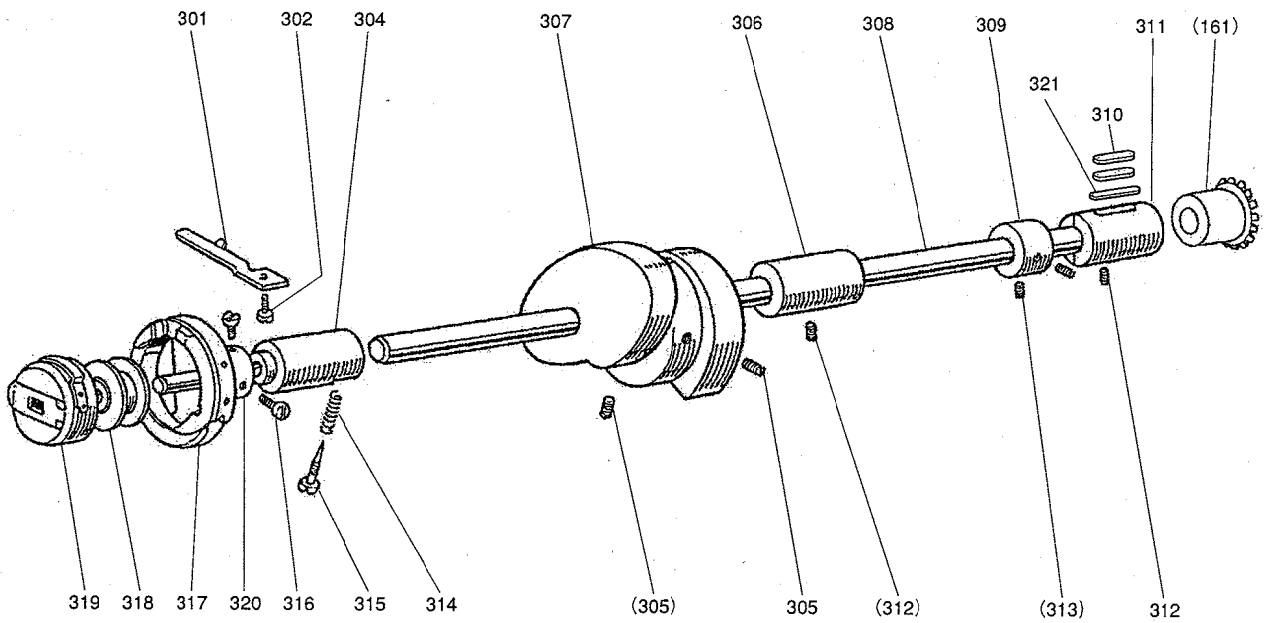

[G]下軸・カマ機構

HOOK SHAFT AND HOOK MECHANISM

Fig no.	変更 Mod.	部品コード Parts no.	品名	Description	数量 Amt. Req.
G 301		MF20A0229	ウチカマトメ	Hook positioner	1
G 302		M90990002	ヒラネジ M4X8	Screw M4X8	1
G 304		MS10A0451	シタジクメタル (ヒタリ)	Hook shaft bushing (L)	1
G 305		M91602020	ロックアナツキトメネジ 1/4(40)X10	Screw 1/4(40)X10	2
G 306		MF00A0453	シタジクメタル (ナカ)	Hook shaft bushing (C)	1
G 307		MF00A0350	イキリカム	Thread trimmer cam	1
G 308		MB61A0450	シタジク	Hook shaft	1
G 309		MF01E0352	カラー	Collar	1
G 310		MF60A0740	フェルト	Felt	2
G 311		MB61E0452	シタジクメタルミキクミタテ	Hook shaft bushing (right) assy	1
G 312		M95002020	ロックアナツキトメネジ M5X6	Screw M5X6	2
G 313		M91106001	トメネジ 11/64(40)X3.75	Screw 11/64(40)X3.75	2
G 314		MG30A0700	ツルマキハネ	Spring	1
G 315		M90801006	ヒラネジホウサキ M3X9.5	Screw M3X9.5	1
G 316		M91103002	ヒラネジ 11/64(40)X5	Screw 11/64(40)X5	2
G 317	A	ME20A0120	カマクミタテ	Hook complete	1
G 318		MF25B0123	ホビン	Bobbin	1
G 319		MG44E0125	ホビンケース	Bobbin case	1
G 320	A	M90800086	オイルシール	Oil seal	1
G 321		MB61A0148	ヒモ	Felt	1

糸切り機構
 THREAD TIMMING MECHANISM

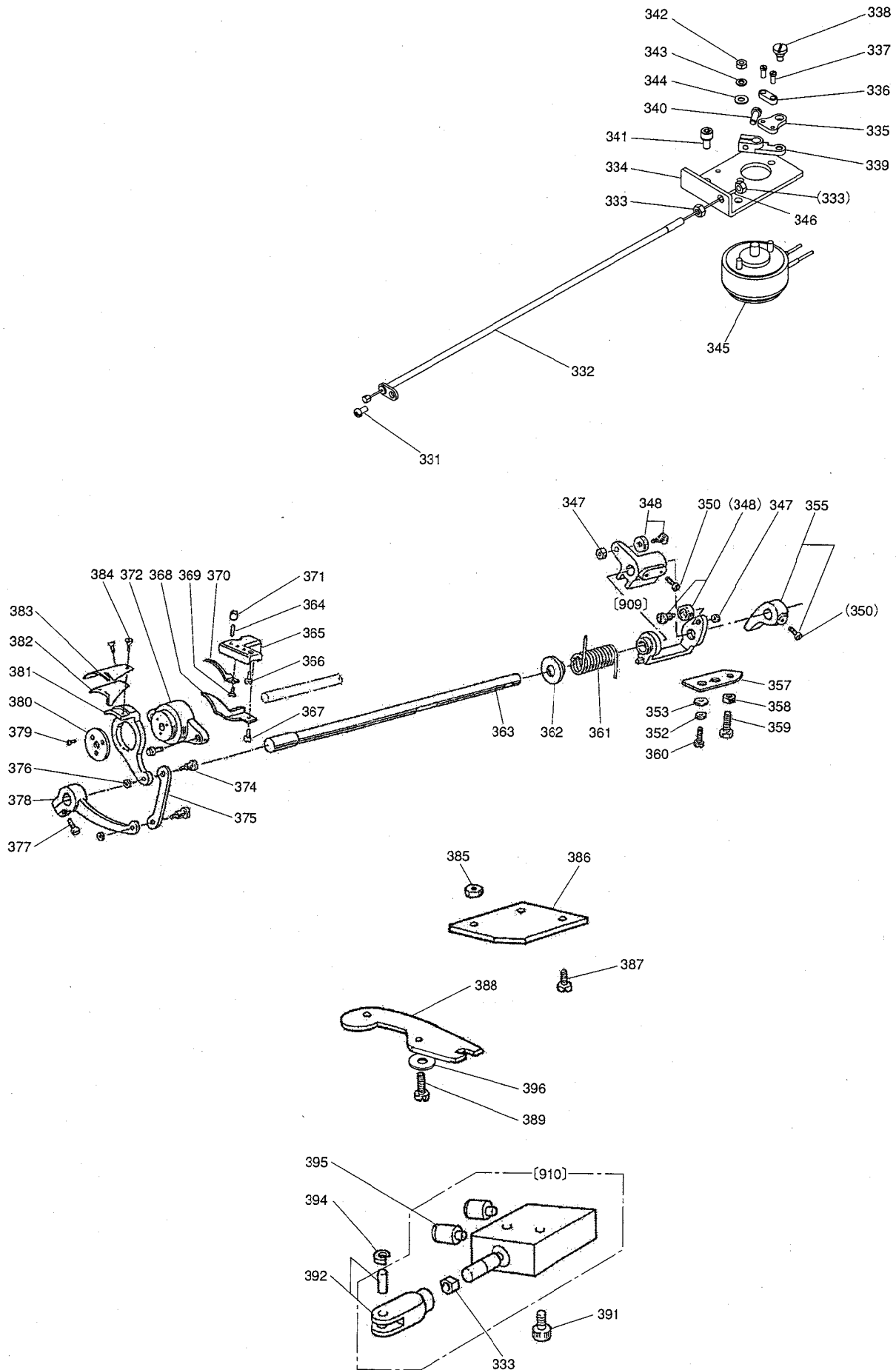

[H]糸切り機構

THREAD TRIMMING MECHANISM

Fig no.	変更 Mod.	部品コード Parts no.	品名	Description	数量 Amt. Req.
H 331		M91054004	SW-PWフライナイナベネジ M4X8	Screw M4X8	1
H 332		MA10E0746	フレキシブルワイヤクミタテ	Flexible wire assy	1
H 333	A	M91382045	ナット M5	Nut M5	2
H 334		MA20A0603	トリツケイタ	Solenoid adapter	1
H 335		MF90A0361	カケガネ	Bracket	1
H 336		MF36A0750	ホルダ	Holder	1
H 337	A	M90825002	ヒラネジ 1/8(44)X10	Screw 1/8(44)X10	2
H 338		M91127015	ヒラネジダンツキ 11/64(40)	Screw 11/64(40)	1
H 339		MS07A0228	ウテ	Crank	1
H 340		M91112002	ヒラネジ 11/64(40)X12	Screw 11/64(40)X12	1
H 341	A	M95005017	セフティソケット M5X10	Bolt M5X10	2
H 342	A	M91007045	ナット M4	Nut M4	2
H 343	A	M90424053	ハネサガネ 4	Spring washer 4	2
H 344	A	M90422050	サガネ 4	Washer 4	2
H 345		MB61E0519	ロータリソレノイドクミタテ	Rotary solenoid assy	1
H 346	A	MN60A0750	ブッシュ	Pipe	1
H 347		M91201045	ナット 3/16(28)	Nut 3/16(28)	2
H 348		MF01E0411	コロ, コロジククミタテ	Cam follow, Shoulder screw assy	2
H 350	A	M91501022	ホルト 15/64(28)X10	Bolt 15/64(28)X10	3
H 352		M90101053	ハネサガネ 5	Spring washer 5	2
H 353		M90552050	コサガネ 5	Washer 5	2
H 355	A	ME20E0477	ストップクミタテ	Stopper	1
H 357		MF00A1477	ストップイタ	Stopper plate	1
H 358		M91502045	ナット 15/64(28)	Nut 15/64(28)	1
H 359		M91512022	ホルト 15/64(28)X23	Bolt 15/64(28)X23	1
H 360		M95009021	ロッカアナツキホルト M5X8	Bolt M5X8	2
H 361		MS10A0572	ツルマキハネ	Coil spring	1
H 362		MF00A0750	ブッシュ		1
H 363		MS10A0454	メスユウトウシク	Knife driving shaft	1
H 364		M90913001	トメネジ 9/64(40)X8.5	Screw 9/64(40)X8.5	1
H 365		MF00A1603	トリツケダイ	Bracket for fixed blade	1
H 366		M90990002	ヒラネジ M4X8	Screw M4X8	4
H 367		M90921002	ヒラネジ 9/64(40)X8	Screw 9/64(40)X8	1
H 368	A	MS07A0180	イトアンナイ	Thread guide	1
H 369		M90907010	サラネジ 9/64(40)X5	Screw 9/64(40)X5	1
H 370		MS10A0838	コテイメス	Fixed blade	1
H 371		M91110045	ナット 9/64(40)	Nut 9/64(40)	1
H 372		MF00A1527	ダイサ	Knife holding bracket saddle	1
H 374		M91111015	ヒラネジダンツキ 11/64(40)X6.2	Stud screw 11/64(40)X6.2	2
H 375		MF00A8910	リンク	Link	1
H 376		M91107045	ナット 11/64(40)	Nut 11/64(40)	2
H 377		M91117002	マルヒラネジ 11/64(40)X11.4	Screw 11/64(40)X11.4	1
H 378		MF00A0392	クドウテ	Knife driving crank	1
H 379		M90803010	サラネジ 1/8(44)X6	Screw 1/8(44)X6	3
H 380		M94006052	トクシサガネ φ28	Special washer φ28	1
H 381		MS07A0836	メスダイ (ヒダリ)	Knife base (left)	1
H 382		MS07A0782	ホゴイタ	Guard plate	1
H 383		MF02A0834	メス (ヒダリ)	Movable knife (left)	1
H 384		M91151010	サラネジ 11/64(40)X7	Screw 11/64(40)X7	2
H 385		M91202045	ナット 3/16(28)	Nut 3/16(28)	1
H 386		MS07A1603	トリツケイタ	Adapter	1
H 387		M91054004	SW-PWフライナイナベネジ M4X8	Screw M4X8	2
H 388		MF00A0391	クドウイタ	Thread trimmer driving lever	1
H 389		M91212015	ヒラネジダンツキ 3/16(28)X6.5	Screw 3/16(28)X6.5	1
H 391		M95005017	セフティソケット M5X10	Bolt M5X10	2
H 392	A	MB25C2621	ナックル	Knuckle	1
H 394		M90331065	Cガ外メワ 5	C-type retaining ring 5	1
H 395		MA20A5571	ツギテ	Connector	2
H 396	A	M90834050	シム	Washer	1
H 909		MB61E0351	カムツイジュウウテクミタテ	Cam follower crank assy	1
H 910		MA16A1434	フリーマウントシリンダクミタテ	Air cylinder	1

J X-Yテーブル機構
 X-Y TABLE MECHANISM

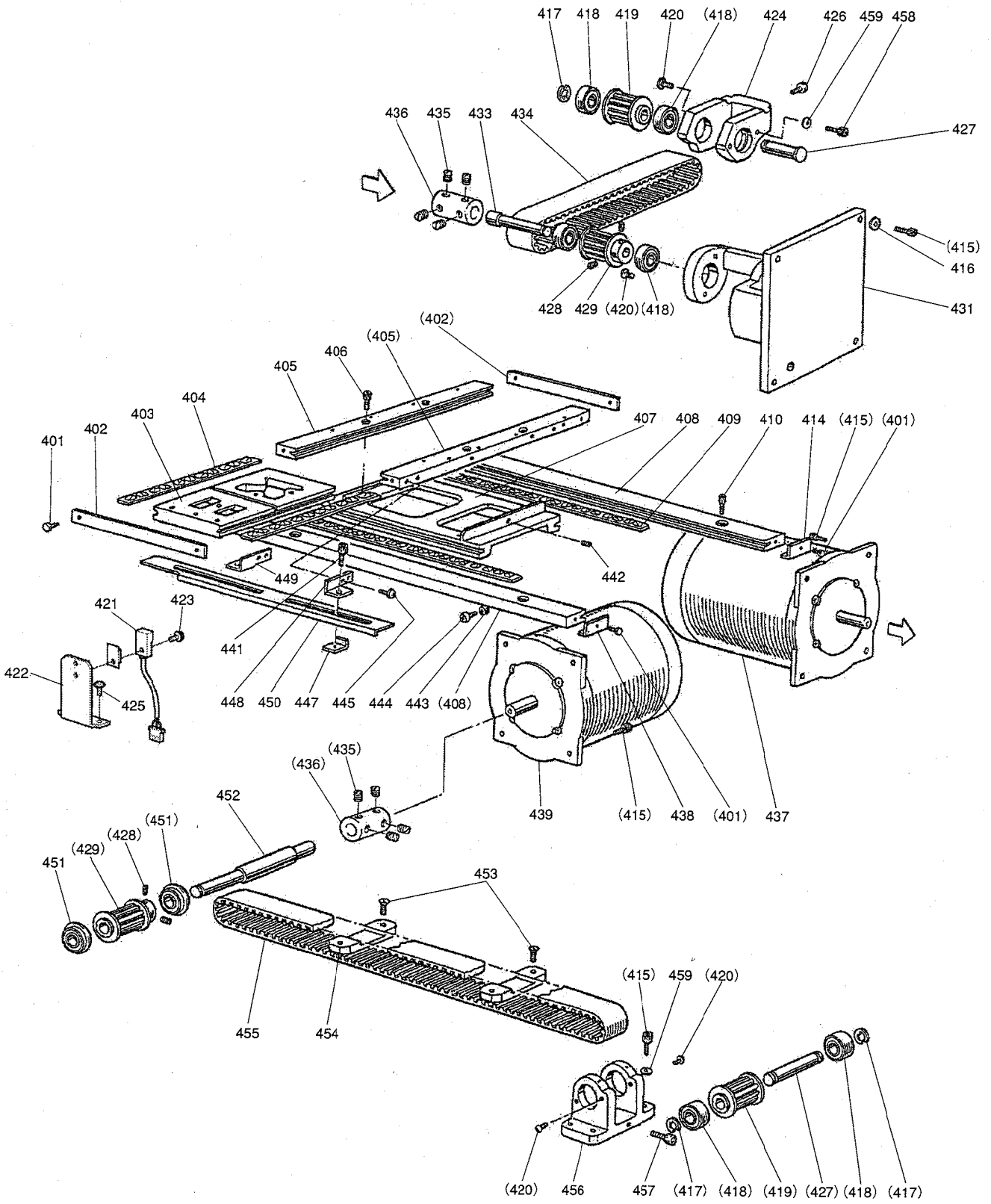

[J]X-Yテーブル機構
X-Y TABLE MECHANISM

Fig no.	変更 Mod.	部品コード Parts no.	品名	Description	数量 Amt. Req.
J 401		M91003022	SUSボルト M4X8	Bolt M4X8	8
J 402		MA04A0477	ストッパ (Y)	Stopper (Y)	2
J 403		MB61A0957	Yジクタイトウレース	Y-movable race	1
J 404		MS10A0972	スライドベアリング	Slide bearing	2
J 405		MB61A1957	Yジクコテイレース	Y-Fixed race	2
J 406		M94002017	セフティソケット M4X8	Bolt M4X8	4
J 407		MB60A1957	Xジクタイトウレース	Moving race (X)	1
J 408		MB61A2957	Xジクコテイレース	X-Fixed race	2
J 409		MS12A0972	スライドベアリング	Slide bearing	2
J 410		M94007017	セフティソケット M4X]12	Bolt M4X12	8
J 414		MS02A4477	ストッパ	Stopper	2
J 415		M95004017	セフティソケット M5X16	Bolt M5X16	16
J 416		M90512050	コサガネ 5	Washer 5	4
J 417		M90604065	E カタメワ 8	E-type retaining ring 8	4
J 418		MS02A2456	シールドボールベアリング	Bearing	6
J 419		MB61A0767	タイミングプーリー	Cog pulley	2
J 420		M91071004	SW-MWプラマイナベネジ M4X8	Screw M4X8	8
J 421		ME20A0484	キンセツスイッチ	Detector	1
J 422		ME10A0408	ケンシュツダイ (X)	Detector bracket (X)	1
J 423		M90971004	SW-PWプラマイナベネジ M3X10	Screw M3X10	1
J 424		MB61A0758	ブラケット	Bracket	1
J 425	A	M91054004	SW-PWプラマイナベネジ M4 × 8	Screw M4 × 8	2
J 426	A	M95006021	ロッカアナツキトメネジ M5X30	Screw M5X30	1
J 427		MS02A1454	ジク	Shaft	2
J 428	A	M96001001	ナイロケットメネジ M6X8	Screw M6X8	4
J 429	A	MB61A2767	タイミングプーリー	Cog pulley	2
J 431		MB61A1758	ブラケット	Bracket	1
J 433		MB61A1454	Yクトウジク	Y-drive shaft	1
J 434		MB61A0523	タイミングベルト	Cog belt (Y)	1
J 435	A	M96002001	ナイロケットメネジ M6X6	Screw M6X6	8
J 436		MB61A0571	ジクツギテ	Coupling	2
J 437		M95043095	ステッピングモータクミタテ	Motor complete	1
J 438		M95044095	ストッパ	Stopper	2
J 439		M95044095	ステッピングモータクミタテ	Motor complete	1
J 441	A	M94008017	セフティソケット M4X6	Bolt M4X6	2
J 442		M93005020	ロッカアナツキトメネジ M3X5	Screw M3X5	1
J 443		M91007045	ロッカナット M4	Nut M4	2
J 444		M94002021	ロッカアナツキボルト M4X16	Bolt M4X16	2
J 445		M90859004	SW-PWプラマイナベネジ M3X6	Screw M3X6	4
J 447		MB60A2601	ケンシュツハントリツケイタ	Bracket	2
J 448		MB60A1429	ケンシュツハンササエ (R)	Bracket (right)	1
J 449		MB60A0429	ケンシュツハンササエ (L)	Bracket (left)	1
J 450		MB61A0407	ケンシュツハン (X)	Detector plate (X)	1
J 451		MB62A0456	ベアリング	Bearing	2
J 452		MB61A2454	Xクトウジク	X-drive shaft	1
J 453		M90990002	ヒラネジ M4X8	Screw M4X8	4
J 454		MB60A0778	ベルトオサエ	Belt clamber	2
J 455		MB61A1523	タイミングベルト	Cog belt (X)	1
J 456		MB61A2758	ブラケット	Bracket	1
J 457		M95015021	ロッカアナツキボルト M5X20	Bolt M5X20	1
J 458	A	M95001017	セフティソケット M5X20	Bolt M5X20	2
J 459		M90511050	ミカキサガネ 5	Washer 5	6

☑ 外押え機構 (I)
 WORK HOLDER MECHANISM (I)

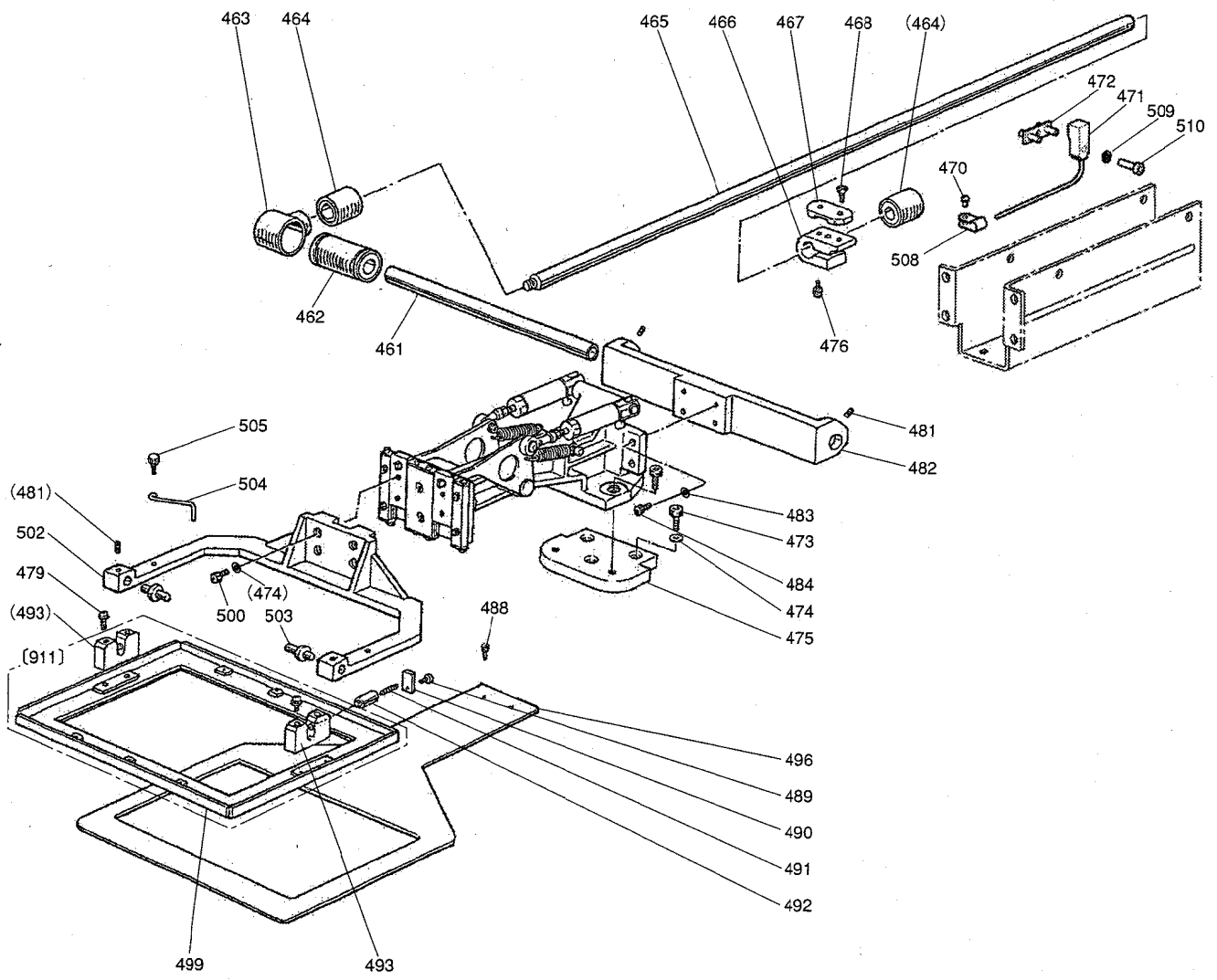

[K]外押え機構(I)
WORK HOLDER MECHANISM(I)

Fig no.	変更 Mod.	部品コード Parts no.	品 名	Description	数量 Amt. Req.
K 461		MS12A0454	ジク	Shaft	1
K 462		M96003070	リニアブッシュ	Bearing	1
K 463		MA20A0692	ジクウケハウジング	Bearing housing	1
K 464	A	MB62A2921	ホールブッシュ	Bearing	2
K 465		ME20A0390	Yクトウジク	Y-drive shaft	1
K 466		MA20A0781	Yベルトダイ	Y-belt holder	1
K 467		MS02A0778	ベルトオサエ	Belt clasper	1
K 468		M91020004	プラマイサラネジ M4X12	Screw M4X12	2
K 470	A	M91054004	SW-PWプラマイナネジ M4X8	Screw M4X8	1
K 471		ME10E1484	キンセツスイッチ	Detector	1
K 472		ME10A2780	ネジイタクミタテ	Holder plate assy	1
K 473		M95003021	ロックアナツキホルト M5X12	Bolt M5X12	3
K 474		M90512050	コサガネ 5	Washer 5	7
K 475		MB61A4601	オサエダイトリツケイタ	Clamp bracket adapter	1
K 476		M95001017	セフティソケット M5X20	Bolt M5X20	1
K 479		M91081004	SW-PWプラマイナネジ M4X18	Screw M4X18	4
K 481		M91053020	ロックアナツキメネジ M4X6	Screw M4X6	4
K 482		MB61A0426	ジクサエ	Shaft holder	1
K 483		M90421050	ミガキサガネ 4	Washer 4	4
K 484		M94006017	セフティソケット M4X16	Bolt M4X16	4
K 488		M95005017	セフティソケット M5X10	Bolt M5X10	2
K 489		M90859004	SW-PWプラマイナネジ M3X6	Screw M3X6	2
K 490		MS02B0257	オサエイタ	Adapter	2
K 491		MS13A0572	コイルバネ	Spring	2
K 492		M90611060	ピン	Pin	2
K 493		MB25B1426	ササエ	Supporter	2
K 496		MB61A0257	シタオサエイタ	Feed plate	1
K 499		MS12A0257	ソトオサエ	Clamp frame	1
K 500		M95010017	セフティソケット M5X12	Bolt M5X12	4
K 502		MB61A0273	オサエウテ	Clamp adapter	1
K 503	A	ME40A0454	オサエジク	Clamp stud	2
K 504		MB61A2477	ストップハ	Stopper	1
K 505		MA20A0650	ナールノブ	Knurled knobs	1
K 508		M94003099	ナイロンクリップ AB-3N	Nylon clip AB-3N	1
K 509	A	M90316050	サガネ 3	Washer 3	1
K 510		M93011021	ロックアナツキホルト M3X12	Bolt M3X12	1
K 911		MB61E0105	ソトオサエクミタテ	Clamp frame assy	1

□ 外押え機構 (Ⅱ)
 WORK HOLDER MECHANISM (Ⅱ)

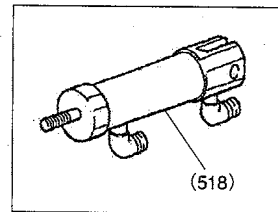
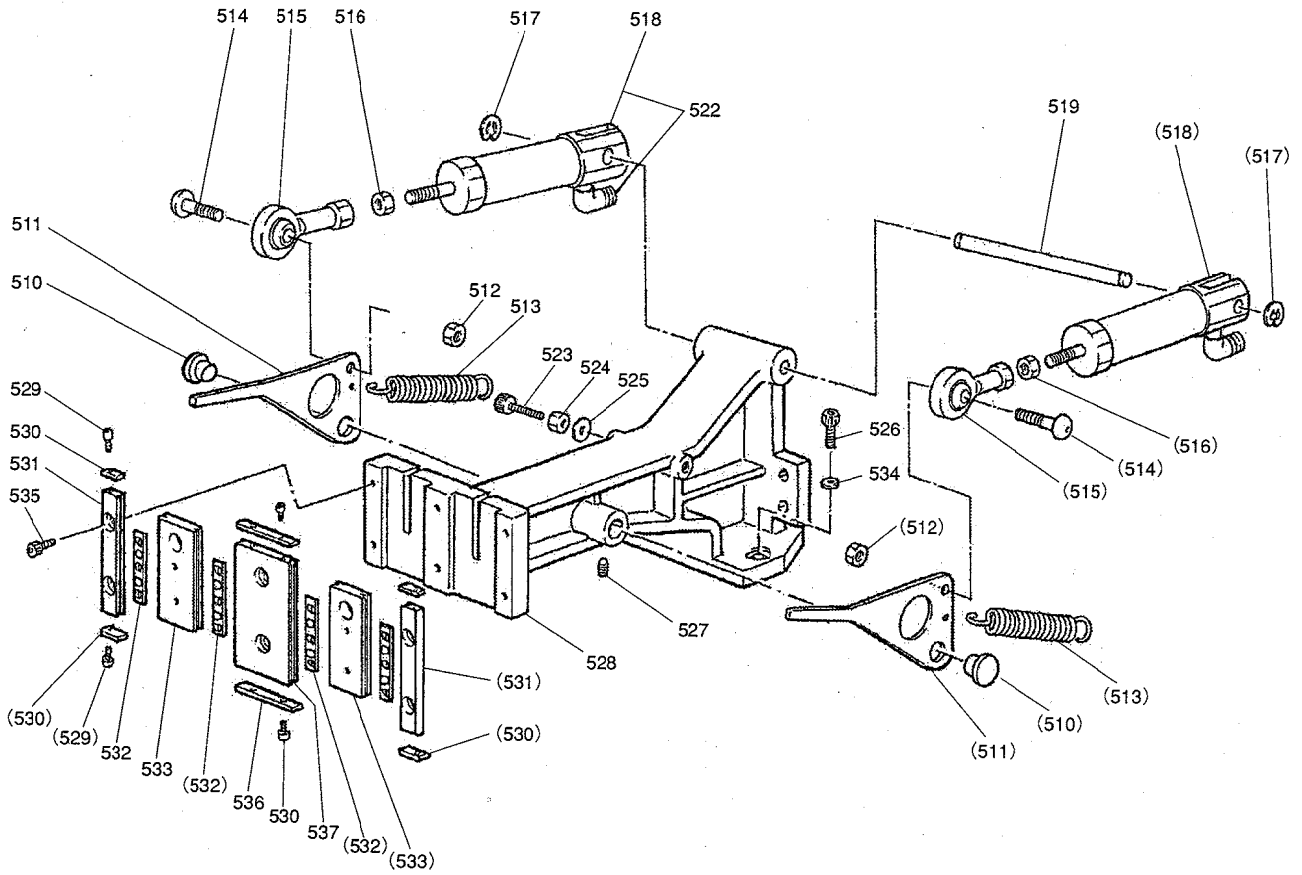

[L]外押え機構(Ⅱ)
WORK HOLDER MECHANISM(Ⅱ)

Fig no.	変更 Mod.	部品コード Parts no.	品名	Description	数量 Amt. Req.
L 510	A	MB61A3454	ツハツキジク	Shaft	2
L 511		MB61A0950	オサエレバー	Pushing lever	2
L 512		M91382045	ロックナット M5	Nut M5	2
L 513		ML10A7572	ツルマキバネ	Spring	2
L 514		M95037021	ロックアナツキボルト M5X16	Bolt M5X16	2
L 515		MN55A0975	ロッドエンド	Rod end bearing	2
L 516		M91379045	トメナット M5	Nut M5	2
L 517		M90504065	Eカトメワ 4	E-type retaining ring 4	2
L 518		MB61A0434	エアシリンダ (タンドウ)	Air cylinder (single acting)	2
L 519		M90531060	クレビスピン	Pin	1
L 522		MB61A1571	ワンタッチツギテ (エルボ)	Fitting	2
L 523		M94015021	ロックアナツキボルト M4X20	Bolt M4X20	2
L 524		M91007045	ロックナット M4	Nut M4	2
L 525		M90421050	ミカキザガネ 4	Washer 4	2
L 526		M96001017	セフティソケット M6X16	Bolt M6X16	2
L 527		M91055020	ロックアナツキトメネジ M4X4	Screw M4X4	2
L 528		MB61A0308	オサエダイ	Clamp bracket	1
L 529		M94012017	セフティソケット M3X8	Bolt M3X8	8
L 530		MB61A1477	ストッパ	Stopper	4
L 531		MB61A3957	オサエコテイレース	Fixed race	2
L 532		M94008070	ローラリテーナ	Slide bearing	4
L 533		MB61A4957	オサエイトウレース	Movable race	2
L 534	A	M90631050	ザガネ 6	Washer 6	2
L 535		M94001017	セフティソケット M4X10	Bolt M4X10	6
L 536		MA17A0477	ストッパ	Stopper	2
L 537		MB61A5957	オサエコテイレース	Fixed race	1

復動押え仕様 (Double Acting method)

L 518		MB61A1434	エアシリンダ (フクトウ)	Air cylinder (double acting)	(2)
-------	--	-----------	---------------	------------------------------	-----

ワイパー機構
WIPER MECHANISM

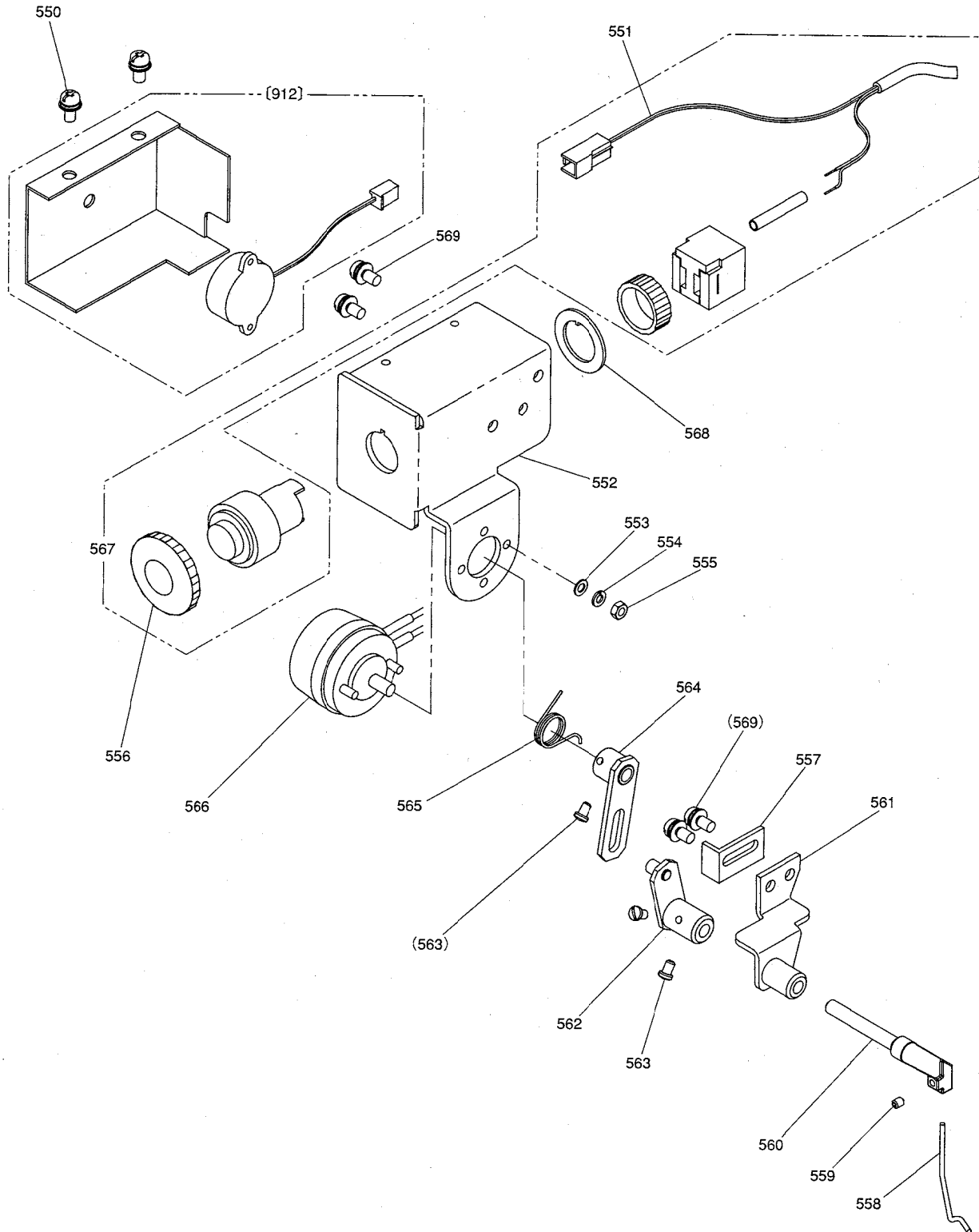

[M]ワイパー機構
WIPER MECHANISM

Fig no.	変更 Mod.	部品コード Parts no.	品名	Description	数量 Amt. Req.
M 550		M91054004	SW-PW ⁺ ラマイナ ⁺ ベ ⁺ ネジ ⁺ M4X8	Screw M4X8	2
M 551	A	M97356099	セツクテンセン	Cable	1
M 552		ME10E3601	トリツケイタ	Bracket	1
M 553		M90317050	コザガネ 3	Washer 3	2
M 554		M90307053	ハネサガネ 3	Spring washer 3	2
M 555		M90875045	ロックナット M3	Nut M3	2
M 556	A	ME03A0270	プッシュボタン	Push button	1
M 557		MS02A1477	ストッパ	Stopper	1
M 558	A	MA20A0980	ワイパー	Wiper	1
M 559		M91057020	ロックアナツキメネジ M3X4	Screw M3X4	1
M 560		MB61E0982	ワイパ ⁺ シ ⁺ ク ⁺ ミ ⁺ タ ⁺	Wiper shaft assy	1
M 561		MS10A0982	ワイパ ⁺ タ ⁺ イ ⁺ ク ⁺ ミ ⁺ タ ⁺	Wiper adapter assy	1
M 562		MB61A0436	ジ ⁺ ウ ⁺ ト ⁺ ウ ⁺ イ ⁺ タ ⁺ ク ⁺ ミ ⁺ タ ⁺	Wiper crank	1
M 563		M90802003	マルヒラネジ 1/8(44)X4.5	Screw 1/8(44)×4.5	4
M 564		MS02E0983	ク ⁺ ト ⁺ ウ ⁺ イ ⁺ タ ⁺ ク ⁺ ミ ⁺ タ ⁺	Wiper crank	1
M 565		MS02A4729	ヒネリハネ	Spring	1
M 566		MB61E1519	ワイパ ⁺ ソ ⁺ レ ⁺ ノ ⁺ イ ⁺ ト ⁺ ク ⁺ ミ ⁺ タ ⁺	Rotary solenoid for wiper	1
M 567		ME10E0270	オンボ ⁺ タ ⁺ ン ⁺ ス ⁺ イ ⁺ ツ ⁺ ク ⁺ ミ ⁺ タ ⁺	Push switch	1
M 568		MB60A0915	マワリ ⁺ メ ⁺ リ ⁺ ン ⁺ グ	Lock Ring	1
M 569	A	M91056004	SW-PW ⁺ ラマイナ ⁺ ベ ⁺ ネジ ⁺ M4X10	Screw M4X10	4
M 912		MB60E3339	カハ ⁺ ク ⁺ ミ ⁺ タ ⁺ (フ ⁺ ザ ⁺ ツ ⁺ キ)	Cover complete (with buzzer)	1

[N]給油機構

OIL LUBRICATION MECHANISM

Fig no.	変更 Mod.	部品コード Parts no.	品名	Description	数量 Amt. Req.
N 601		MS03A2780	ホルダ	Holder	1
N 602		MS10A0148	パイプヒモクミタテ	Oil pipe complete	1
N 603		MS10A2148	パイプヒモクミタテ	Oil pipe complete	1
N 604		MS10A1148	パイプヒモクミタテ	Oil pipe complete	1
N 605	A	MN60A0620	ナイロンクリップ AB-5N	Nylon clip AB-5N	2
N 606		M91054004	SW-PWフライナネジ M4X8	Screw M4X8	9
N 607		MS10A3148	パイプヒモクミタテ	Oil pipe complete	1
N 608		MS10A0688	パイプ	Pipe	1
N 609		MB61E1688	パイプヒモクミタテ	Oil pipe complete	1
N 610		MS10A0780	ホルダ	Holder	1
N 611		MN10A0135	アブラマト	Oil gauge	2
N 612		M95014021	ロッククアナツキホルト M5X14	Bolt M5X14	1
N 613		MB61A0780	ホルダ	Holder	1
N 614		MS10A1742	アブラブタ	Cap	1
N 615		MS10A1691	ガスケット	Gasket	1
N 616		MB61E0688	パイプフェルトクミタテ	Oil pipe complete	1
N 617		MG43A0689	センザイクハネ	Pipe holder	1
N 618		MF36A0689	ホルダ	Holder	1
N 619		M91007045	ナット M4	Nut M4	1
N 620	A	M91015004	フライナネジ M4X12	Screw M4X12	1
N 621	A	M91058004	SW-PWフライナネジ M4X6	Screw M4X6	1
N 622		ME10A1780	ホルダ	Holder	1
N 623		MS10A5148	パイプクミタテ	Oil pipe complete	1
N 624		MF80A0780	ホルダ	Holder	1
N 625		MB61E0742	フタクミタテ	Cap assy	1
N 626		MF10A2740	フェルト	Felt	1
N 627		M90573080	ゴムセン	Rubber plug	2
N 628		M90531037	Pナネジ M5X14	Screw M5X14	1
N 629	A	ME20A2780	ホルダ	Holder	1
N 630	A	M91056004	SW-PWフライナネジ M4X10	Screw M4X10	4
N 631	A	MS14A1620	ナイロンクリップ AB-4N	Nylon clip AB-4N	2
N 913		MB61E0711	ハグルマハコウエクミタテ	Arm shaft bevel gear box complete	1
N 914		MB61E0712	ハグルマハコシタクミタテ	Hook shaft bevel gear box complete	1

□ 配線・配管関係

CABLE COMPONENT AND PNEUMATIC CONTROL UNIT

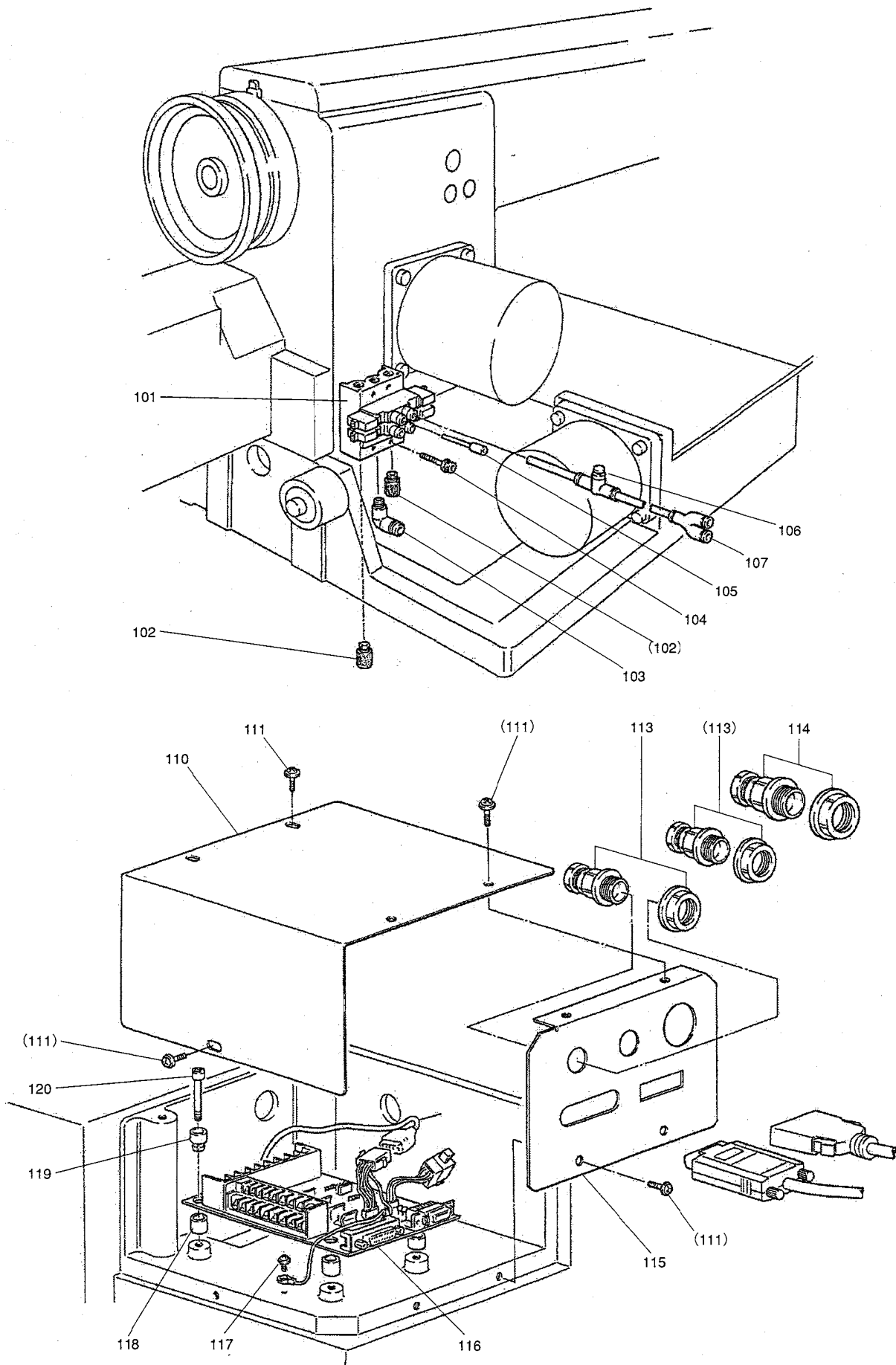

[P]配線・検出器関係

CABLE COMPONENT & DETECTOR MECHANISM

Fig no.	変更 Mod.	部品コード Parts no.	品名	Description	数量 Amt. Req.
P 101		MB61E0599	ソレノイドバルブミタテ	Solenoid valve complete	1
P 102		M91035089	サイレンサ	Muffler	2
P 103		MA20A8571	Lガタツキテ	Connector	1
P 104		M91276004	SW-PWプラマイナヘネジ M4X30	Screw M4X30	4
P 105		MB62A0757	プラグ	Plug	1
P 106	A	MA20A0497	スピードコントローラ	Speed controller	1
P 107		MA20A6571	Yガタツキテ	Connector	1
P 110		MB60A5339	Pバンカバー	Circuit board cover	1
P 111	A	M91071004	SW-MWプラマイナヘネジ M4X8	Screw M4X8	7
P 113	A	MB60A6780	コードブッシュ (小)	Cord bushing (small)	2
P 114	A	MB60A5780	コードブッシュ (大)	Cord bushing (large)	1
P 115		MB60A5601	コネクタ外リツケイタ	Connector panel	1
P 116	A	M800E2CON	Pバルブミタテ PLK-E2-CON	Print circuit board	1
P 117		M90439037	SWプラマイナヘネジ M4X8	Screw M4X8	1
P 118		MB60A2352	スペーサ	Spacer	4
P 119		MB60A0366	キャップ	Screw adapter	4
P 120		M91057004	SW-PWプラマイナヘネジ M4X20	Screw M4X20	4

Q テーブル関係
TABLE & STAND

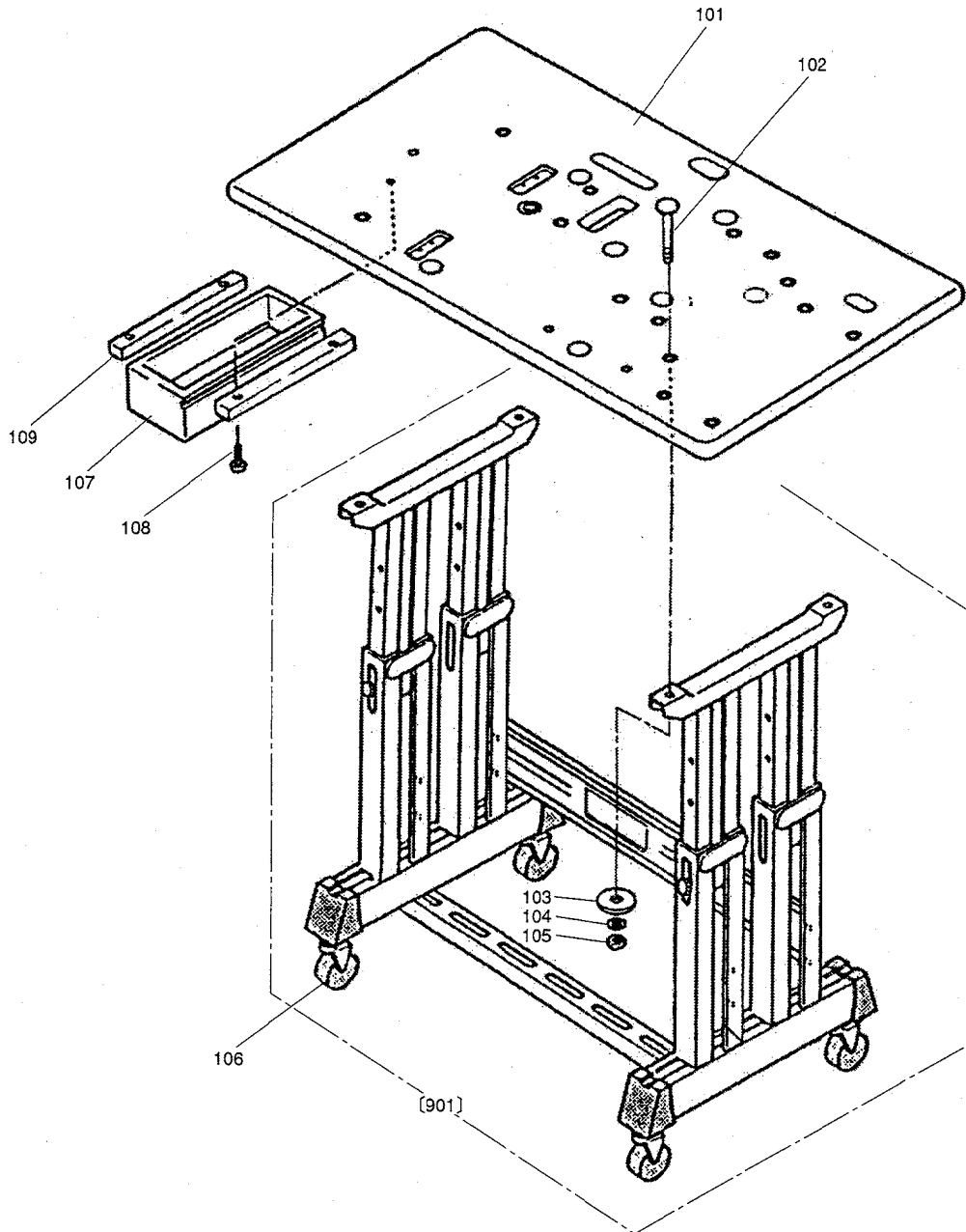

[Q]テーブル関係
TABLE & STAND

Fig no.	変更 Mod.	部品コード Parts no.	品 名	Description	数量 Amt. Req.
Q 101		ME20A0595	テシイタ	Table top	1
Q 102		M92055022	トリツケホルト M8X70	Mounting Bolt M8X70	4
Q 103		M90710050	トクシユサガネ 8	Special washer 8	4
Q 104		M90802053	ハネサガネ 8	Spring washer 8	4
Q 105		M92008045	ナツト M8	Nut M8	4
Q 106		MB60A1368	キャスト	Caster	4
Q 107		MB60A0719	ヒキタシ	Drawer	1
Q 108		M90406040	Pサラムクネジ φ4.5X38	Screw φ4.5X38	4
Q 109		MB60A3957	レール	Rail	2
Q 915		MB25E0150	キャク (クミ)	Leg assy	1

Ⓜ 付属品 (I)
ACCESSORIES (I)

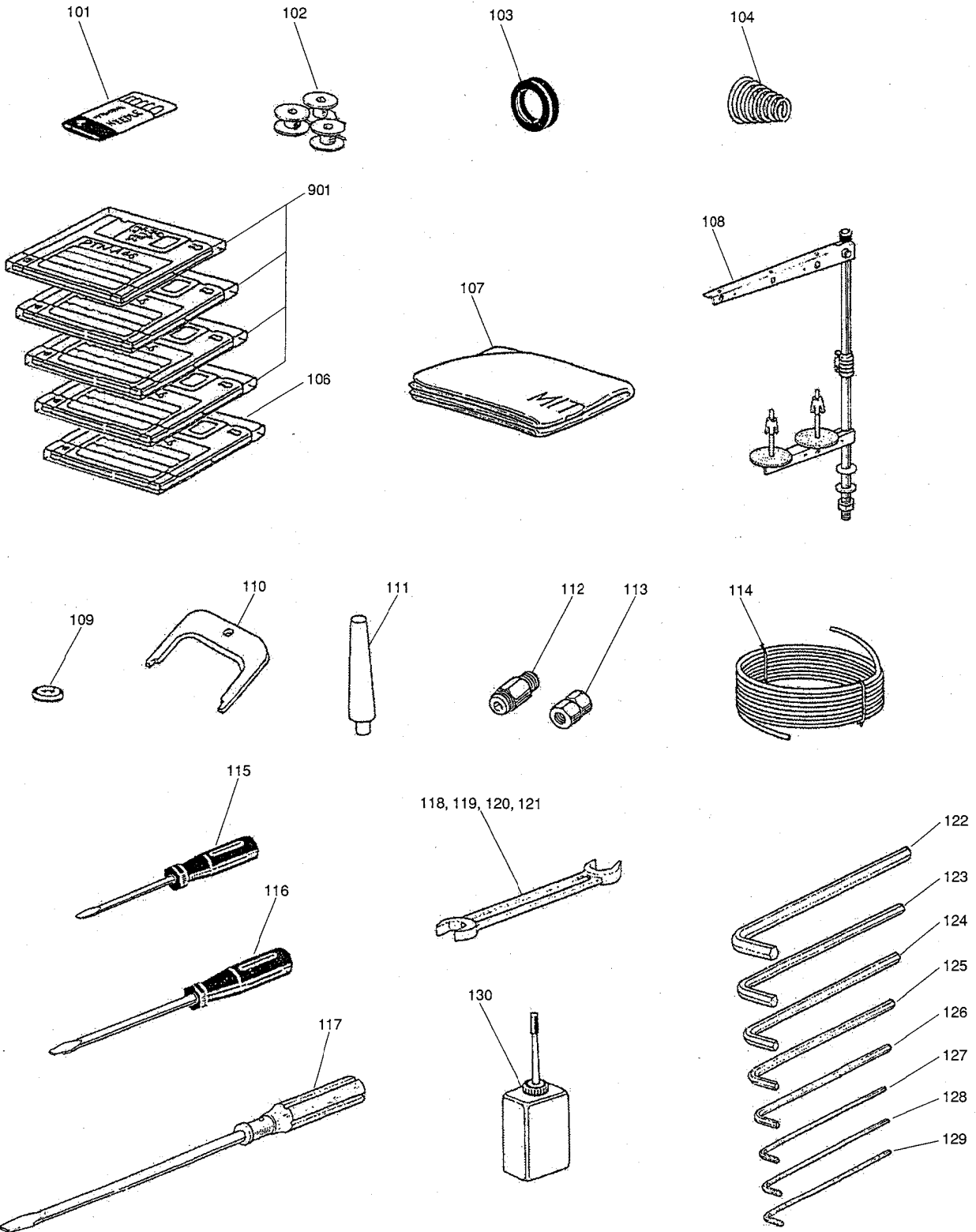

[R] 付属品(1)
ACCESSORIES(1)

Fig no.	変更 Mod.	部品コード Parts no.	品 名	Description	数量 Amt. Req.
R 101		MS02A0128	ミシンハリ DPX17#18	Needle DPX17#18	4
R 102		MF25B0123	ホビン	Bobbin	3
R 103		MS03A0417	ゴムワ	Tire	1
R 104		MN52A1245	エンスイバネ	Tension spring	1
R 105		ME20E0990	システムフロッピーディスク (4マイ)	System F/D (4discs)	1
R 106		MB60A1990	データフロッピーディスク	Pattern data F/D	1
R 107		MA20A0734	ビニールカバー	Polyethylene cover	1
R 108		MF40E0193	イタテダイクミタテ	Cotton stand complete	1
R 109		MB60A0419	ホウシンゴム	Rubber cushion	6
R 110		MF01A0565	カクチョウセイグ	Detector adjusting plate	1
R 111		MA20A0613	トウフササエ	Head rest	1
R 112		MA30A0571	ワタツツキテ	Connector	1
R 113		M91010089	ソケット	Socket	1
R 114		MS06A0567	ウレタンチューブ	Tube	1
R 115		MB02A1608	ネジマワシ (ショウ)	Screw driver (small)	1
R 116		MB02A0608	ネジマワシ (チュウ)	Screw driver (middle)	1
R 117		MF00A0608	ネジマワシ (ダイ)	Screw driver (large)	1
R 118		MS02A0479	リョウグチスパナ 13X17	Spanner 13X17	1
R 119		MM10A1479	リョウグチスパナ 10X14	Spanner 10X14	1
R 120		MS10A1976	リョウグチスパナ 8X9	Spanner 8X9	1
R 121		MS10A2976	リョウグチスパナ 6X7	Spanner 6X7	1
R 122		MS05A1976	ソケットハウスパナ 6	Socket wrench 6	1
R 123		MS05A0976	ソケットハウスパナ 5	Socket wrench 5	1
R 124		MS01A1976	ソケットハウスパナ 4	Socket wrench 4	1
R 125		MF90A0976	ソケットハウスパナ 1/8	Socket wrench 1/8	1
R 126		MS02A2976	ソケットハウスパナ 3	Socket wrench 3	1
R 127		MS02A1976	ソケットハウスパナ 2.5	Socket wrench 2.5	1
R 128		MS02A0976	ソケットハウスパナ 2	Socket wrench 2	1
R 129		MS10A0976	ソケットハウスパナ 1.5	Socket wrench 1.5	1
R 130		MF10A0149	アブラサシ	Oiler with oil	1

S 付属品 (Ⅱ)
 ACCESSORIES (Ⅱ)

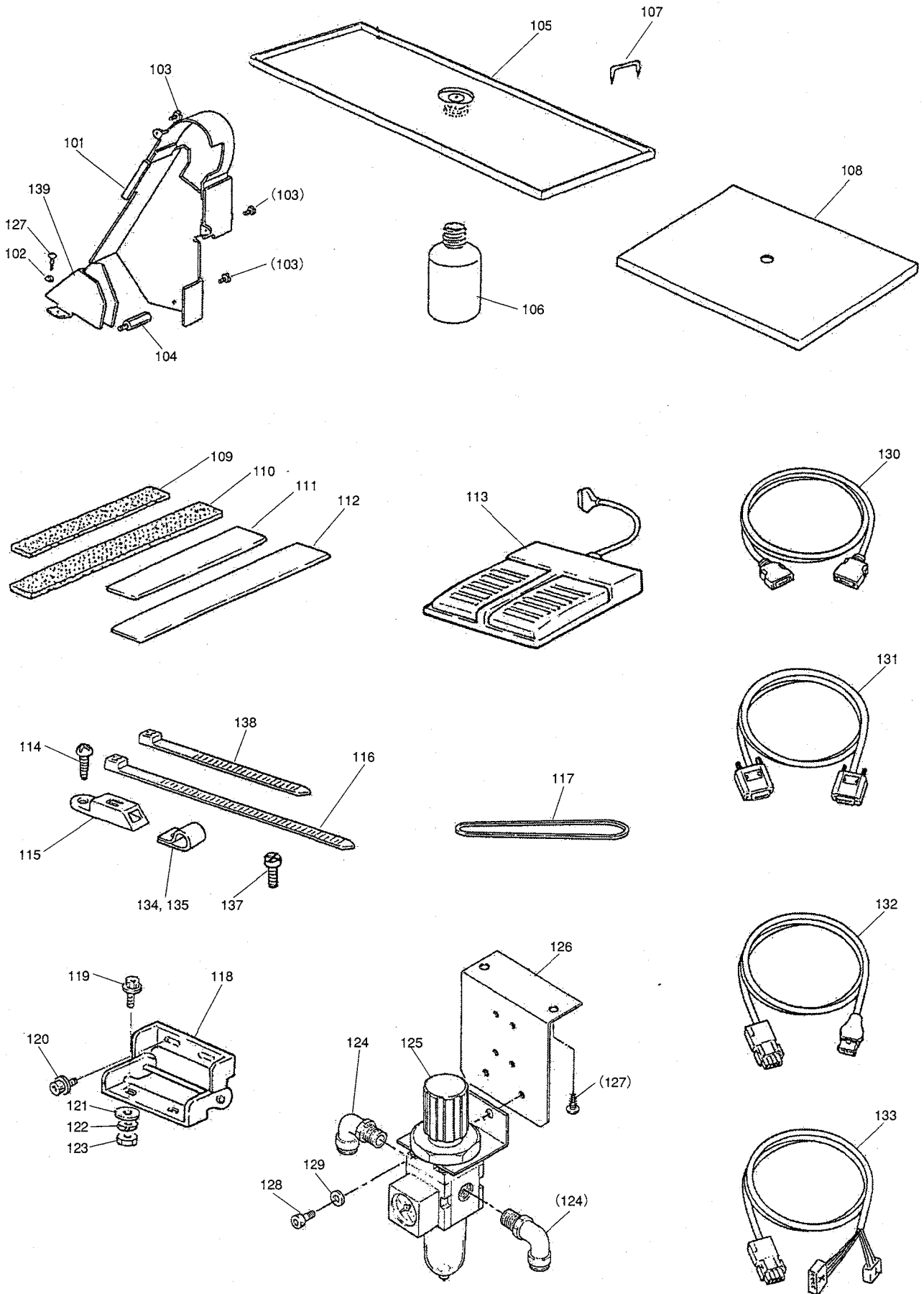

[S] 付属品(2)
ACCESSORIES(2)

Fig no.	変更 Mod.	部品コード Parts no.	品名	Description	数量 Amt. Req.
S 101		MB61E0776	ベルトカバークミタテ	Belt cover assy	1
S 102		M90511050	ワッシャー 5	Washer 5	2
S 103		M91067004	SW-PWフライナナネジ M5X10	Screw M5X10	3
S 104		M95001031	トクシュボルト	Bolt	1
S 105		MB61E0139	アブラソウクミタテ	Oil pan complete	1
S 106		MF20A0130	アブラビン	Oil bottle	1
S 107		M90001043	ステッフル	Staple	7
S 108		MB61A0797	ホコフィルム	Slide plate guard film	1
S 109		MB61A3691	ハッキン	Clamp pad	2
S 110		MB61A2691	ハッキン	Clamp pad	2
S 111		MB61A1691	ハッキン	Clamp pad	2
S 112		MB61A0691	ハッキン	Clamp pad	2
S 113		M860A0FSW	フットスイッチ	Foot switch	1
S 114	A	M90306041	マルモクネジ 3.1X16	Wood screw 3.1X16	4
S 115		MB60A0420	コテイグ	Tie holder	2
S 116		MB60A0201	インシュロックタイ	Cord tie	2
S 117		MS10A0777	Vベルト M51	V-belt M51	1
S 118		MB60A0560	ヒンジ	Hinge	2
S 119	A	M96020021	ロクカクアナツキボルト M6X55	Screw M6X55	4
S 120		M96002017	セフティソケット M6X12	Bolt M6X12	4
S 121		M90630050	トクシュワッシャー	Special washer	4
S 122		M90624053	バネワッシャー 6	Spring washer 6	4
S 123		M91571045	ナット M6	Nut M6	4
S 124		MA20A8571	ワンタッチツギテ (エルボ)	Connector	2
S 125		ME40A0963	フィルタレギュレータ	Filter regulator	1
S 126		MB61A5601	レギュレータトリツケイタ	Filter regulator adapter	1
S 127		M90409041	マルモクネジ 4.5X20	Wood screw 4.5X20	4
S 128		M95003017	セフティソケット M5X8	Bolt M5X8	2
S 129		M90511050	ワッシャー 5	Washer 5	2
S 130		M97319099	セツクセン ミンIN	Cable (input signal)	1
S 131		M97320099	セツクセン ミンOUT	Cable (output of solenoid)	1
S 132		M97318099	セツクセン サーボ	Cable (servo motor)	1
S 133	A	M97321099	ケーブル (ステッピングモータ)	Cable (stepping motor)	1
S 134		MB60A1620	ナイロンクリップ AB-8N	Nylon clip AB-8N	1
S 135		MB60A2620	ナイロンクリップ AB-10N	Nylon clip AB-10N	1
S 137		M90439037	SW-PWフライナナネジ M4X8	Screw M4X8	2
S 138		MG51A0201	インシュロックタイ	Cord tie	1
S 139		MS08A2776	ベルトカバー (S)	Belt cover (S)	1
S 140		M90632050	ワッシャー 6	Washer 6	3

□ オプションパーツ
OPTION PARTS

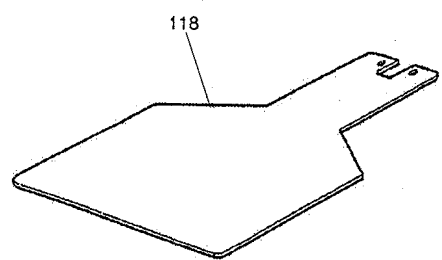
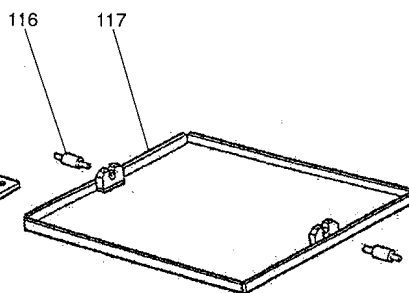
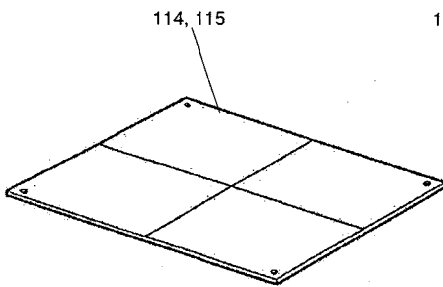
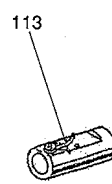
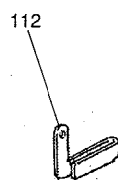
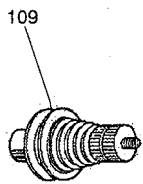
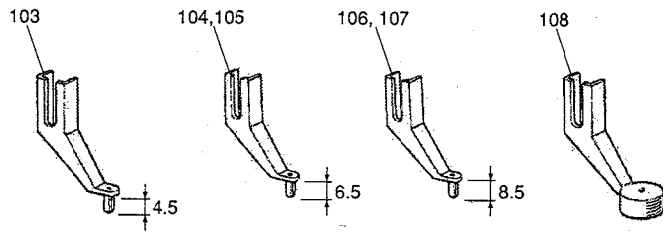
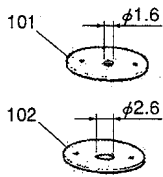

[T]オプションパーツ
OPTION PARTS

Fig no.	変更 Mod.	部品コード Parts no.	品名	Description	数量 Amt. Req.
T 101		MS02A0101	ハリイタ φ1.6	Needle plate φ1.6	1
T 102		MS02A1101	ハリイタ φ2.6	Needle plate φ2.6	1
T 103		MV30A1256	ナカオサエ φ2	Presser foot φ2	1
T 104	A	MS03A0256	ナカオサエ φ3	Presser foot φ3	1
T 105		MS03A1256	ナカオサエ φ2	Presser foot φ2	1
T 106		MA35A0256	ナカオサエ φ3	Presser foot φ3	1
T 107		MA35A1256	ナカオサエ φ2	Presser foot φ2	1
T 108		MV35A0106	ナカオサエ φ2 (サラ)	Presser foot (Flat)	1
T 109		MS04E1210	ウワイトチョウセツキミタテ	Threaded tension regulator complete	1
T 110		MF10A1245	エンスイハネ (プリテンション)	Thread pretension spring	1
T 111		MN10A3245	エンスイハネ (ウワイトチョウセツキ)	Thread tension regulator spring	1
T 112		MS03A0181	イトアンナイクミタテ	Thread guide complete	1
T 113		MS10A0180	イトアンナイクミタテ	Thread guide complete	1
T 114		MB61A0762	ナカオサエイタ (2t, ケガキセンアリ)	Clamp plate (with line)	1
T 115		MB61A1762	ナカオサエイタ (2t, ケガキセンナシ)	Clamp plate	1
T 116		MA20A3454	オサエシク	Clamp stud	2
T 117		MB61E1105	ソトオサエクミタテ (アナナン)	Clamp frame assy (blank)	1
T 118		MB61A1272	シタオサエイタ (アナナン)	Feed plate (blank)	1

索引
INDEX-1

部品コード Parts No.	ページ Page	Fig No.	部品コード Parts No.	ページ Page	Fig No.	部品コード Parts No.	ページ Page	Fig No.	部品コード Parts No.	ページ Page	Fig No.
M800E2CON	...	P27	...	P	116	M90825002	...	P15	...	H	337
M860A0FSW	...	P33	...	S	113	M90834050	...	P15	...	H	396
M90001043	...	P33	...	S	107	M90858004	...	P7	...	D	121
M90101053	...	P15	...	H	352	M90859004	...	P5	...	C	53
M90204060	...	P5	...	C	79	↑	...	P19	...	K	489
M90306041	...	P33	...	S	114	↑	...	P17	...	J	445
M90307053	...	P23	...	M	554	M90875045	...	P23	...	M	555
M90316050	...	P19	...	K	509	M90883080	...	P3	...	B	3
M90317050	...	P23	...	M	553	M90901002	...	P5	...	C	75
M90325065	...	P11	...	F	251	M90906003	...	P3	...	B	42
M90330065	...	P9	...	E	182	M90907010	...	P15	...	H	369
M90331065	...	P15	...	H	394	M90909003	...	P11	...	F	238
M90406040	...	P29	...	Q	108	↑	...	P5	...	C	64
M90409041	...	P33	...	S	127	M90913001	...	P15	...	H	364
M90421050	...	P21	...	L	525	M90920002	...	P7	...	D	97
↑	...	P19	...	K	483	M90921002	...	P15	...	H	367
↑	...	P9	...	E	195	M90922002	...	P11	...	F	262
M90422050	...	P15	...	H	344	M90939002	...	P7	...	D	99
M90423060	...	P11	...	F	268	M90971004	...	P17	...	J	423
M90424053	...	P15	...	H	343	M90990002	...	P9	...	E	165
M90439037	...	P27	...	P	117	↑	...	P13	...	G	302
↑	...	P33	...	S	137	↑	...	P17	...	J	453
↑	...	P33	...	S	137	↑	...	P15	...	H	366
M90504065	...	P21	...	L	517	↑	...	P3	...	B	35
M90511050	...	P33	...	S	129	↑	...	P7	...	D	127
↑	...	P17	...	J	459	M91003022	...	P17	...	J	401
↑	...	P33	...	S	102	M91004067	...	P7	...	D	119
M90512050	...	P19	...	K	474	M91005067	...	P7	...	D	120
↑	...	P17	...	J	416	M91007045	...	P25	...	N	619
M90531037	...	P25	...	N	628	↑	...	P15	...	H	342
M90531060	...	P21	...	L	519	↑	...	P17	...	J	443
M90552050	...	P15	...	H	353	↑	...	P21	...	L	524
M90573080	...	P3	...	B	20	M91010089	...	P31	...	R	113
↑	...	P25	...	N	627	M91011004	...	P5	...	C	59
M90602064	...	P7	...	D	111	M91013004	...	P7	...	D	98
M90604065	...	P17	...	J	417	M91015004	...	P25	...	N	620
M90605010	...	P3	...	B	33	M91020004	...	P19	...	K	468
M90611060	...	P19	...	K	492	M91035089	...	P27	...	P	102
M90624053	...	P33	...	S	122	M91053020	...	P5	...	C	69
M90630050	...	P33	...	S	121	↑	...	P9	...	E	145
M90631050	...	P21	...	L	534	↑	...	P19	...	K	481
↑	...	P11	...	F	246	M91054004	...	P25	...	N	606
↑	...	P3	...	B	16	↑	...	P3	...	B	2
M90632050	...	P33	...	S	140	↑	...	P17	...	J	425
↑	...	P11	...	F	256	↑	...	P23	...	M	550
↑	...	P33	...	S	140	↑	...	P19	...	K	470
M90710050	...	P29	...	Q	103	↑	...	P7	...	D	92
M90800086	...	P13	...	G	320	↑	...	P15	...	H	387
M90801006	...	P13	...	G	315	↑	...	P15	...	H	331
M90802003	...	P23	...	M	563	M91055004	...	P3	...	B	22
M90802053	...	P29	...	Q	104	M91055020	...	P7	...	D	110
M90803010	...	P15	...	H	379	↑	...	P21	...	L	527
M90806002	...	P3	...	B	24	M91056004	...	P25	...	N	630
M90815002	...	P9	...	E	169	↑	...	P11	...	F	227
M90823050	...	P3	...	B	6	↑	...	P9	...	E	194
M91056004	...	P23	...	M	569	M91056004	...	P23	...	M	569
↑	...	P3	...	B	14	↑	...	P3	...	B	14
M91057004	...	P27	...	P	120	M91057004	...	P27	...	P	120
M91057020	...	P7	...	D	107	M91057020	...	P7	...	D	107
↑	...	P23	...	M	559	↑	...	P23	...	M	559
M91058004	...	P25	...	N	621	M91058004	...	P25	...	N	621
↑	...	P3	...	B	13	↑	...	P3	...	B	13
M91058020	...	P11	...	F	236	M91058020	...	P11	...	F	236
M91066004	...	P3	...	B	30	M91066004	...	P3	...	B	30
M91067004	...	P33	...	S	103	M91067004	...	P33	...	S	103
M91071004	...	P27	...	P	111	M91071004	...	P27	...	P	111
↑	...	P17	...	J	420	↑	...	P17	...	J	420
↑	...	P3	...	B	9	↑	...	P3	...	B	9
M91081004	...	P19	...	K	479	M91081004	...	P19	...	K	479
M91101046	...	P5	...	C	74	M91101046	...	P5	...	C	74
M91103002	...	P13	...	G	316	M91103002	...	P13	...	G	316
M91106001	...	P13	...	G	313	M91106001	...	P13	...	G	313
M91107045	...	P15	...	H	376	M91107045	...	P15	...	H	376
M91110002	...	P3	...	B	23	M91110002	...	P3	...	B	23
M91110045	...	P15	...	H	371	M91110045	...	P15	...	H	371
M91111015	...	P15	...	H	374	M91111015	...	P15	...	H	374
M91112002	...	P15	...	H	340	M91112002	...	P15	...	H	340
M91117002	...	P15	...	H	377	M91117002	...	P15	...	H	377
M91127015	...	P15	...	H	338	M91127015	...	P15	...	H	338
M91131002	...	P11	...	F	269	M91131002	...	P11	...	F	269
M91151010	...	P15	...	H	384	M91151010	...	P15	...	H	384
M91182080	...	P5	...	C	65	M91182080	...	P5	...	C	65
M91201045	...	P15	...	H	347	M91201045	...	P15	...	H	347
M91202045	...	P15	...	H	385	M91202045	...	P15	...	H	385
M91212015	...	P15	...	H	389	M91212015	...	P15	...	H	389
M91219015	...	P11	...	F	270	M91219015	...	P11	...	F	270
M91221001	...	P9	...	E	161	M91221001	...	P9	...	E	161
M91276004	...	P27	...	P	104	M91276004	...	P27	...	P	104
M91304080	...	P3	...	B	4	M91304080	...	P3	...	B	4
M91379045	...	P21	...	L	516	M91379045	...	P21	...	L	516
M91382045	...	P15	...	H	333	M91382045	...	P15	...	H	333
↑	...	P21	...	L	512	↑	...	P21	...	L	512
M91501022	...	P15	...	H	350	M91501022	...	P15	...	H	350
M91502045	...	P15	...	H	358	M91502045	...	P15	...	H	358
M91504031	...	P11	...	F	267	M91504031	...	P11	...	F	267
M91506001	...	P11	...	F	259	M91506001	...	P11	...	F	259
M91512022	...	P15	...	H	359	M91512022	...	P15	...	H	359
M91520002	...	P9	...	E	190	M91520002	...	P9	...	E	190
M91551015	...	P11	...	F	248	M91551015	...	P11	...	F	248
M91571045	...	P33	...	S	123	M91571045	...	P33	...	S	123
M91572045	...	P11	...	F	245	M91572045	...	P11	...	F	245
M91602001	...	P9	...	E	146	M91602001	...	P9	...	E	146
M91602020	...	P13	...	G	305	M91602020	...	P13	...	G	305
M91602046	...	P7	...	D	106	M91602046	...	P7	...	D	106
M91603003	...	P11	...	F	244	M91603003	...	P11	...	F	244
M91606001	...	P11	...	F	252	M91606001	...	P11	...	F	252
↑	...	P9	...	E	163	↑	...	P9	...	E	163
M91610001	...	P9	...	E	149	M91610001	...	P9	...	E	149
M91610046	...	P5	...	C	84	M91610046	...	P5	...	C	84
M91688015	...	P11	...	F	232	M91688015	...	P11	...	F	232
M91689015	...	P11	...	F	231	M91689015	...	P11	...	F	231
M91801035	...	P11	...	F	224	M91801035	...	P11	...	F	224
M91802006	...	P9	...	E	141	M91802006	...	P9	...	E	141
M91802045	...	P11	...	F	225	M91802045	...	P11	...	F	225
M91803022	...	P3	...	B	10	M91803022	...	P3	...	B	10
M91910080	...	P5	...	C	60	M91910080	...	P5	...	C	60
M92008045	...	P29	...	Q	105	M92008045	...	P29	...	Q	105
M92055022	...	P29	...	Q	102	M92055022	...	P29	...	Q	102
M93001050	...	P9	...	E	183	M93001050	...	P9	...	E	183
M93005020	...	P17	...	J	442	M93005020	...	P17	...	J	442
M93011021	...	P19	...	K	510	M93011021	...	P19	...	K	510
M93202047	...	P11	...	F	254	M93202047	...	P11	...	F	254
M93220035	...	P11	...	F	253	M93220035	...	P11	...	F	253
M94001017	...	P21	...	L	535	M94001017	...	P21	...	L	535
M94001030	...	P3	...	B	19	M94001030	...	P3	...	B	19
M94002017	...	P17	...	J	406	M94002017	...	P17	...	J	406
M94002021	...	P17	...	J	444	M94002021	...	P17	...	J	444
M94003099	...	P19	...	K	508	M94003099	...	P19	...	K	508
M94006017	...	P19	...	K	484	M94006017	...	P19	...	K	484
M94006052	...	P15	...	H	380	M94006052	...	P15	...	H	380
M94007017	...	P17	...	J	410	M94007017	...	P17	...	J	410
M94008017	...	P17	...	J	441	M94008017	...	P17	...	J	441
M94008070	...	P21	...	L	532	M94008070	...	P21	...	L	532
M94012017	...	P21	...	L	529	M94012017	...	P21	...	L	529
M94015021	...	P21	...	L	523	M94015021	...	P21	...	L	523
M95001017	...	P19	...	K	476	M95001017	...	P19	...	K	476
↑	...	P17	...	J	458	↑	...	P17	...	J	458
M95001031	...	P33	...	S	104	M95001031	...	P33	...	S	104
M95002020	...	P9	...	E	192	M95002020	...	P9	...	E	19

索引
INDEX-2

部品コード Parts No.	ページ Page	Fig No.	部品コード Parts No.	ページ Page	Fig No.	部品コード Parts No.	ページ Page	Fig No.	部品コード Parts No.	ページ Page	Fig No.
M96020021	...	P33	...	S	119	MB60A1620	...	P33	...	S	134
M97318099	...	P33	...	S	132	MB60A1957	...	P17	...	J	407
↑	...	P33	...	S	132	MB60A1990	...	P31	...	R	106
M97319099	...	P33	...	S	130	MB60A2352	...	P27	...	P	118
↑	...	P33	...	S	130	MB60A2601	...	P17	...	J	447
M97320099	...	P33	...	S	131	MB60A2620	...	P33	...	S	135
↑	...	P33	...	S	131	↑	...	P33	...	S	135
M97321099	...	P33	...	S	133	MB60A3957	...	P29	...	Q	109
↑	...	P33	...	S	133	MB60A5339	...	P27	...	P	110
M97356099	...	P23	...	M	551	MB60A5601	...	P27	...	P	115
M99006063	...	P7	...	D	116	MB60A5780	...	P27	...	P	114
↑	...	P11	...	F	237	MB60A6780	...	P27	...	P	113
MA04A0477	...	P17	...	J	402	MB60E0682	...	P9	...	E	191
MA10E0746	...	P15	...	H	332	MB60E1682	...	P9	...	E	906
MA16A0530	...	P7	...	D	108	MB60E3339	...	P23	...	M	912
MA16A1434	...	P15	...	H	910	MB61A0148	...	P13	...	G	321
MA16E0210	...	P5	...	C	902	MB61A0230	...	P9	...	E	151
MA17A0477	...	P21	...	L	536	MB61A0257	...	P19	...	K	496
MA20A0194	...	P7	...	D	115	MB61A0273	...	P19	...	K	502
MA20A0476	...	P7	...	D	95	MB61A0308	...	P21	...	L	528
MA20A0497	...	P27	...	P	106	MB61A0407	...	P17	...	J	450
MA20A0603	...	P15	...	H	334	MB61A0426	...	P19	...	K	482
MA20A0613	...	P31	...	R	111	MB61A0434	...	P21	...	L	518
MA20A0650	...	P19	...	K	505	MB61A0436	...	P23	...	M	562
MA20A0692	...	P19	...	K	463	MB61A0450	...	P13	...	G	308
MA20A0734	...	P31	...	R	107	MB61A0458	...	P5	...	C	54
MA20A0781	...	P19	...	K	466	MB61A0459	...	P3	...	B	38
MA20A0980	...	P23	...	M	558	MB61A0470	...	P3	...	B	37
MA20A5571	...	P15	...	H	395	MB61A0476	...	P7	...	D	126
MA20A6571	...	P27	...	P	107	MB61A0523	...	P17	...	J	434
MA20A8571	...	P33	...	S	124	MB61A0571	...	P17	...	J	436
↑	...	P27	...	P	103	MB61A0601	...	P3	...	B	17
MA25A0520	...	P9	...	E	156	MB61A0650	...	P3	...	B	36
MA25A0660	...	P9	...	E	171	MB61A0691	...	P33	...	S	112
MA30A0571	...	P31	...	R	112	MB61A0740	...	P9	...	E	177
MB02A0608	...	P31	...	R	116	MB61A0742	...	P3	...	B	5
MB02A1608	...	P31	...	R	115	MB61A0758	...	P17	...	J	424
MB25B1426	...	P19	...	K	493	MB61A0767	...	P17	...	J	419
MB25C2621	...	P15	...	H	392	MB61A0780	...	P25	...	N	613
MB25E0150	...	P29	...	Q	915	MB61A0797	...	P33	...	S	108
MB60A0201	...	P33	...	S	116	↑	...	P3	...	B	44
MB60A0366	...	P27	...	P	119	MB61A0950	...	P21	...	L	511
MB60A0419	...	P31	...	R	109	MB61A0957	...	P17	...	J	403
MB60A0420	...	P33	...	S	115	MB61A1339	...	P3	...	B	18
MB60A0429	...	P17	...	J	449	MB61A1434	...	P21	...	L	518
MB60A0560	...	P33	...	S	118	MB61A1454	...	P17	...	J	433
MB60A0694	...	P9	...	E	188	MB61A1459	...	P3	...	B	39
MB60A0719	...	P29	...	Q	107	MB61A1477	...	P21	...	L	530
MB60A0750	...	P3	...	B	7	MB61A1523	...	P17	...	J	455
MB60A0778	...	P17	...	J	454	MB61A1571	...	P21	...	L	522
MB60A0915	...	P23	...	M	568	MB61A1601	...	P3	...	B	27
MB60A1368	...	P29	...	Q	106	MB61A1691	...	P33	...	S	111
MB60A1429	...	P17	...	J	448	MB61A1758	...	P17	...	J	431
MB60A1601	...	P7	...	D	118	MB61A1957	...	P17	...	J	405
MB60A1620	...	P33	...	S	134	MB61A2454	...	P17	...	J	452
MB61A2459	...	P3	...	B	40	MB61A2477	...	P19	...	K	504
ME10A6910	...	P11	...	F	233	MB61A2601	...	P5	...	C	55
ME10A7910	...	P11	...	F	235	MB61A2691	...	P33	...	S	110
ME10E0270	...	P23	...	M	567	MB61A2758	...	P17	...	J	456
ME10E1484	...	P19	...	K	471	MB61A2767	...	P17	...	J	429
ME10E3601	...	P23	...	M	552	MB61A2957	...	P17	...	J	408
ME20A0120	...	P13	...	G	317	MB61A3339	...	P7	...	D	129
ME20A0339	...	P3	...	B	12	MB61A3454	...	P21	...	L	510
ME20A0352	...	P11	...	F	280	MB61A3601	...	P5	...	C	56
ME20A0390	...	P19	...	K	465	MB61A3691	...	P33	...	S	109
ME20A0406	...	P9	...	E	180	MB61A3957	...	P21	...	L	531
ME20A0408	...	P3	...	B	11	MB61A4601	...	P19	...	K	475
ME20A0426	...	P11	...	F	230	MB61A4957	...	P21	...	L	533
ME20A0477	...	P11	...	F	272	MB61A5601	...	P33	...	S	126
ME20A0484	...	P17	...	J	421	MB61A5957	...	P21	...	L	537
ME20A0530	...	P11	...	F	279	MB61E0105	...	P19	...	K	911
ME20A0595	...	P29	...	Q	101	MB61E0139	...	P33	...	S	105
ME20A0600	...	P7	...	D	91	MB61E0234	...	P9	...	E	148
ME20A0738	...	P11	...	F	271	MB61E0339	...	P7	...	D	122
ME20A0830	...	P3	...	B	21	MB61E0351	...	P15	...	H	909
ME20A2780	...	P25	...	N	629	MB61E0359	...	P7	...	D	125
ME20E0190	...	P7	...	D	904	MB61E0452	...	P13	...	G	311
ME20E0477	...	P15	...	H	355	MB61E0476	...	P7	...	D	130
ME20E0750	...	P3	...	B	900	MB61E0519	...	P15	...	H	345
ME20E0990	...	P31	...	R	105	MB61E0521	...	P9	...	E	155
ME25A0434	...	P11	...	F	276	MB61E0599	...	P27	...	P	101
ME25A0530	...	P7	...	D	109	MB61E0688	...	P25	...	N	616
ME25A0551	...	P7	...	D	93	MB61E0711	...	P25	...	N	913
ME25A0571	...	P11	...	F	275	MB61E0712	...	P25	...	N	914
ME25A0601	...	P11	...	F	274	MB61E0742	...	P25	...	N	625
ME25A0950	...	P7	...	D	94	MB61E0750	...	P7	...	D	117
ME40A0454	...	P19	...	K	503	MB61E0776	...	P33	...	S	101
ME40A0571	...	P11	...	F	281	MB61E0849	...	P3	...	B	1
ME40A0963	...	P33	...	S	125	MB61E0982	...	P23	...	M	560
MF00A0181	...	P5	...	C	70	MB61E1339	...	P7	...	D	124
MF00A0350	...	P13	...	G	307	MB61E1476	...	P7	...	D	131
MF00A0391	...	P15	...	H	388	MB61E1519	...	P23	...	M	566
MF00A0392	...	P15	...	H	378	MB61E1688	...	P25	...	N	609
MF00A0453	...	P13	...	G	306	MB61E3339	...	P7	...	D	128
MF00A0608	...	P31	...	R	117	MB62A0456	...	P17	...	J	451
MF00A0750	...	P15	...	H	362	MB62A0626	...	P11	...	F	263
MF00A1477	...	P15	...	H	357	MB62A0757	...	P27	...	P	105
MF00A1527	...	P15	...	H	372	MB62A2921	...	P19	...	K	464
MF00A1603	...	P15	...	H	365	ME03A0270	...	P23	...	M	556
MF00A8910	...	P15	...	H	375	ME10A0261	...	P11	...	F	226
MF00E0550	...	P5	...	C	901	ME10A0408	...	P17	...	J	422
MF01A0259	...	P9	...	E	184	ME10A0572	...	P11	...	F	228
MF01A0476	...	P9	...	E	187	ME10A0742	...	P3	...	B	32
MF01A0565	...	P31	...	R	110	ME10A0763	...	P11	...	F	234
MF01A1476	...	P9	...	E	185	ME10A0956	...	P11	...	F	247
MF01E0352	...	P13	...	G	309	ME10A1252	...	P11	...	F	265
MF01E0411	...	P15	...	H	348	ME10A1780	...	P25	...	N	622
MF02A0834	...	P15	...	H	383	ME10A1956	...	P11	...	F	241
MF03A0584	...	P5	...	C	61	ME10A2780	...	P19	...	K	472
MF10A0149	...	P31	...	R	130						
MF10A0181	...	P5	...	C	62						

索引
INDEX-3

部品コード Parts No.	ページ Page	Fig No.	部品コード Parts No.	ページ Page	Fig No.	部品コード Parts No.	ページ Page	Fig No.	部品コード Parts No.	ページ Page	Fig No.
MF10A0187	...	P5	...	C	77	MM11A0245	...	P7	...	D	104
MF10A0267	...	P11	...	F	260	MM11A0556	...	P5	...	C	81
MF10A0325	...	P9	...	E	166	MM11A0702	...	P7	...	D	105
MF10A0332	...	P9	...	E	159	MN10A0135	...	P25	...	N	611
MF10A0334	...	P9	...	E	158	MN10A1456	...	P9	...	E	181
MF10A0553	...	P5	...	C	78	MN52A1245	...	P31	...	R	104
MF10A0555	...	P7	...	D	103	↑	...	P5	...	C	82
↑	...	P5	...	C	80	MN55A0975	...	P21	...	L	515
MF10A0664	...	P9	...	E	170	MN60A0620	...	P25	...	N	605
MF10A0709	...	P5	...	C	76	MN60A0750	...	P15	...	H	346
MF10A1555	...	P5	...	C	72	MN70A1780	...	P11	...	F	239
MF10A2740	...	P9	...	E	174	MN72A1694	...	P9	...	E	186
↑	...	P25	...	N	626	MS01A0160	...	P3	...	B	28
MF20A0130	...	P33	...	S	106	MS01A0361	...	P3	...	B	31
MF20A0229	...	P13	...	G	301	MS01A0477	...	P3	...	B	29
MF20A0703	...	P11	...	F	255	MS01A1976	...	P31	...	R	124
MF25B0123	...	P13	...	G	318	MS02A0128	...	P9	...	E	167
↑	...	P31	...	R	102	↑	...	P31	...	R	101
MF36A0245	...	P5	...	C	73	MS02A0259	...	P11	...	F	257
MF36A0689	...	P25	...	N	618	MS02A0463	...	P11	...	F	908
MF36A0750	...	P15	...	H	336	MS02A0479	...	P31	...	R	118
MF36A1180	...	P5	...	C	57	MS02A0778	...	P19	...	K	467
MF40A0331	...	P9	...	E	150	MS02A0976	...	P31	...	R	128
MF40A0333	...	P9	...	E	152	MS02A1101	...	P3	...	B	34
MF40E0193	...	P31	...	R	108	MS02A1454	...	P17	...	J	427
MF60A0700	...	P11	...	F	249	MS02A1477	...	P23	...	M	557
MF60A0740	...	P9	...	E	153	MS02A1976	...	P31	...	R	127
↑	...	P13	...	G	310	MS02A2456	...	P17	...	J	418
MF60A0742	...	P9	...	E	175	MS02A2976	...	P31	...	R	126
MF60A1383	...	P9	...	E	142	MS02A4477	...	P17	...	J	414
MF70A0350	...	P11	...	F	266	MS02A4729	...	P23	...	M	565
MF70A1180	...	P5	...	C	85	MS02B0257	...	P19	...	K	490
MF80A0352	...	P9	...	E	147	MS02E0460	...	P11	...	F	242
MF80A0780	...	P25	...	N	624	MS02E0983	...	P23	...	M	564
MF90A0361	...	P15	...	H	335	MS03A0262	...	P11	...	F	261
MF90A0553	...	P5	...	C	71	MS03A0417	...	P31	...	R	103
MF90A0976	...	P31	...	R	125	↑	...	P7	...	D	114
MG30A0700	...	P13	...	G	314	MS03A2780	...	P25	...	N	601
MG30A0740	...	P11	...	F	240	MS03A6154	...	P11	...	F	229
MG30A0760	...	P11	...	F	907	MS05A0976	...	P31	...	R	123
MG30A0833	...	P11	...	F	243	MS05A1976	...	P31	...	R	122
MG30B0740	...	P11	...	F	250	MS05E0580	...	P9	...	E	905
MG42A0181	...	P9	...	E	168	MS06A0567	...	P31	...	R	114
MG43A0181	...	P5	...	C	58	MS07A0180	...	P15	...	H	368
MG43A0689	...	P25	...	N	617	MS07A0228	...	P15	...	H	339
MG43A1181	...	P5	...	C	63	MS07A0782	...	P15	...	H	382
MG44E0125	...	P13	...	G	319	MS07A0836	...	P15	...	H	381
MG44E0662	...	P9	...	E	164	MS07A1603	...	P15	...	H	386
MG50A0740	...	P9	...	E	144	MS08A2776	...	P33	...	S	139
MG51A0201	...	P33	...	S	138	↑	...	P33	...	S	139
↑	...	P33	...	S	138	MS10A0148	...	P25	...	N	602
MG75A0265	...	P11	...	F	258	MS10A0192	...	P3	...	B	41
MG75A1476	...	P7	...	D	100	MS10A0232	...	P9	...	E	143
ML10A7572	...	P21	...	L	513	MS10A0451	...	P13	...	G	304
MM10A1479	...	P31	...	R	119	MS10A0454	...	P15	...	H	363
MS10A0522	...	P9	...	E	157						
MS10A0572	...	P15	...	H	361						
MS10A0663	...	P9	...	E	172						
MS10A0688	...	P25	...	N	608						
MS10A0740	...	P9	...	E	154						
MS10A0777	...	P33	...	S	117						
MS10A0780	...	P25	...	N	610						
MS10A0838	...	P15	...	H	370						
MS10A0972	...	P17	...	J	404						
MS10A0976	...	P31	...	R	129						
MS10A0982	...	P23	...	M	561						
MS10A1148	...	P25	...	N	604						
MS10A1456	...	P3	...	B	8						
MS10A1691	...	P25	...	N	615						
MS10A1740	...	P9	...	E	160						
MS10A1742	...	P25	...	N	614						
MS10A1976	...	P31	...	R	120						
MS10A2148	...	P25	...	N	603						
MS10A2976	...	P31	...	R	121						
MS10A3148	...	P25	...	N	607						
MS10A5148	...	P25	...	N	623						
MS12A0257	...	P19	...	K	499						
MS12A0454	...	P19	...	K	461						
MS12A0972	...	P17	...	J	409						
MS13A0572	...	P19	...	K	491						
MS14A0350	...	P7	...	D	112						
MS14A0553	...	P7	...	D	102						
MS14A0572	...	P7	...	D	113						
MS14A0682	...	P9	...	E	162						
MS14A1180	...	P7	...	D	101						
MS14A1620	...	P25	...	N	631						
MS14E0180	...	P7	...	D	903						
MT60A0802	...	P5	...	C	83						
MV30A0256	...	P11	...	F	264						
MV88A0740	...	P9	...	E	193						
MS13A0572	...	P19	...	K	491						
MS14A0350	...	P7	...	D	112						
MS14A0553	...	P7	...	D	102						
MS14A0572	...	P7	...	D	113						
MS14A0682	...	P9	...	E	162						
MS14A1180	...	P7	...	D	101						
MS14A1620	...	P25	...	N	631						
MS14E0180	...	P7	...	D	903						
MT60A0802	...	P5	...	C	83						
MV30A0256	...	P11	...	F	264						
MV30A1256	...	P35	...	T	103						
MV35A0106	...	P35	...	T	108						
MV88A0740	...	P9	...	E	193						

MEMO

A series of horizontal dotted lines for writing.

MEMO

A series of horizontal dotted lines for writing.

MEMO

A series of horizontal dotted lines for writing.

 **三菱電機株式会社**

 **MITSUBISHI ELECTRIC CORPORATION**