

THE EASTMAN® 96-26025 Tool Head Retro Kit

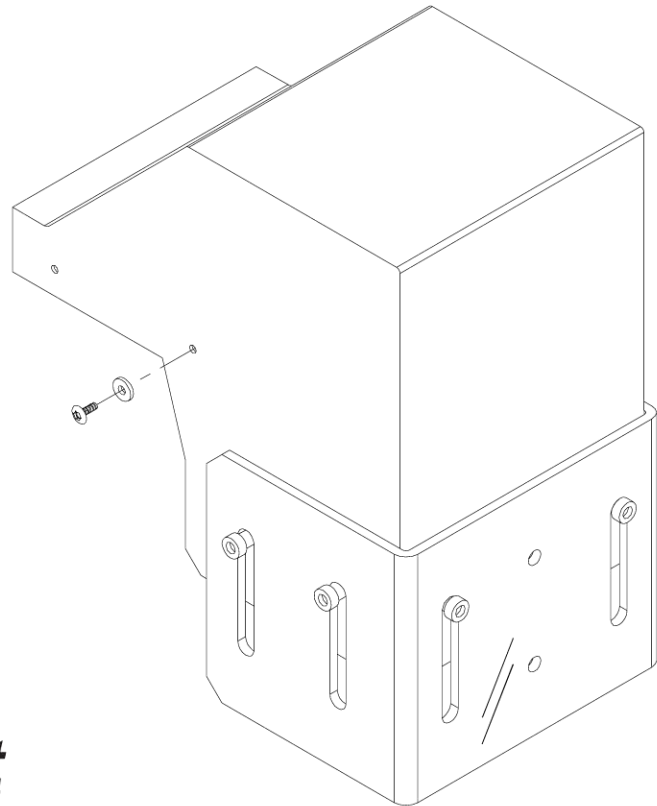
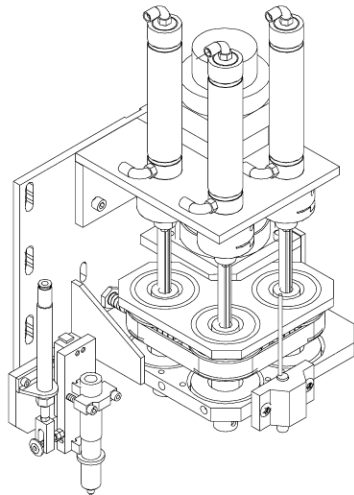

Instructions and Illustrated Parts List

IMPORTANT

The purchaser must instruct all operators on the proper use of the equipment. All standard industrial safety measures and equipment should be provided to protect the operator. Operators must be cautioned that improper or careless use of this equipment may cause personal injury. If you do not have qualified operators to instruct new persons, contact your Eastman sales representative or Eastman factory direct.

Disconnect electrical power source before proceeding with any installation, adjustment or repair of the M9000 Automated Cutting System.

Tool Head Replacement Kit 96-26025 Existing Tool Head Removal

Warning: This machine is equipped with Sharp Blade. Use caution when working around cutting tool area.

1. Disconnect main power source and air supply.
2. Remove tools from existing tool head.
3. Remove existing tool head cover and guard.
4. Mark air tubing location and disconnect air tubing. This will help when installing the new tool head.
5. Remove tool head motor and place on top of gantry using caution not to strain the motor wires.
6. Remove laser pointer assembly.
7. Remove existing tool head mounting screws.
8. Disconnect and remove the tool home switch.
9. Replace Y-Car mounting plate.

96-26025

Tool Head Assembly Kit

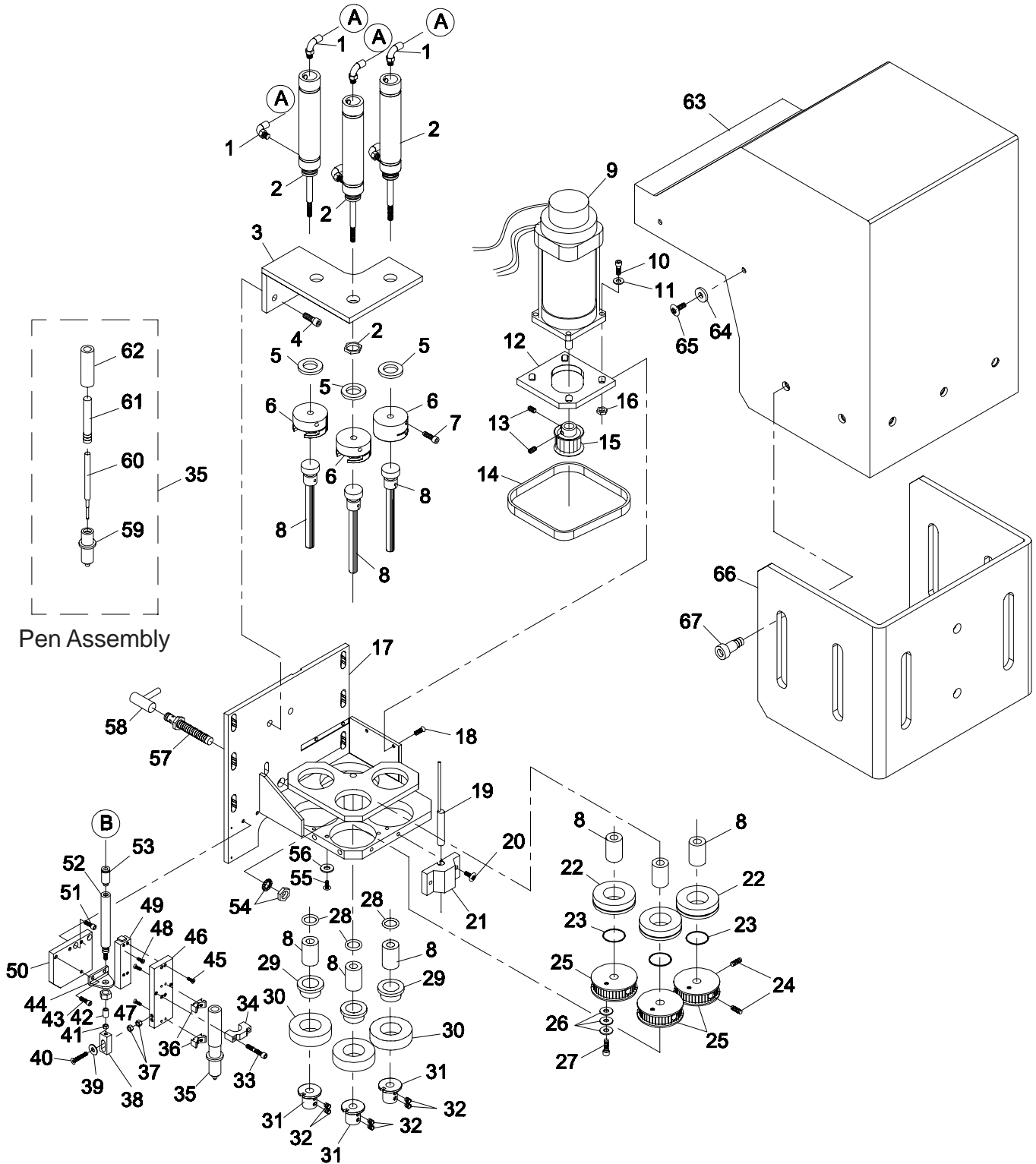

ITEM	PART No.	DESCRIPTION	QTY
1	65-100-13-7	Swivel Elbow, 1/8 npt x 1/4	6
	65-100-13-3	Swivel Elbow, 1/8 npt x 5/32	6
2	67-26092-2	Air Cylinder w/switch	3
	54-26152	Jam Nut, 5/8-18	3
3	67-26190	Cylinder Mounting Bracket	1
4	65-335-34-8	Screw, Socket Hd. 1/4-20 x 1/2	4
5	54-26229	Bumper	3
6	54-26232	Cylinder Coupling, Non-Rotating	3
7	65-335-102-8	Screw, Socket Hd.#10-32 x 1/2	3
8	54-26234	Shaft/Bearing Assembly	3
*9	31-S3205	Z-Motor, Servo w/Connector	1
*10	65-335-93-12	Screw, Socket Hd. #8-32 x 3/4	4
*11	65-402-080	Washer, Lock #8	4
12	67-26188	Motor Mounting Plate	1
13	65-345-93-4	Setscrew, #8-32 x 1/4	2
14	67-12972	Belt, 112 t x 3 mm	1
15	67-26054	Pulley, 22t, .3775 b	1
*16	65-211-93	Stop Nut, #8-32	4
17	67-26191	H9900-3A Tool Head Frame	1
18	65-332-102-6	Screw Flat Hd. 10-32 x 3/8	4
*19	81-00002	Laser Pointer	1
20	65-333-93-8	Screw, Button Hd. #8-32 x 1/2	2
21	54-H0403	Mount, Laser Pointer	1
22	67-26184	Bearing, 16mm ID	3
23	54-26230	Spacer	3
24	65-26009	Setscrew, #6-32 x 1/4	6
25	54-12971	Pulley, 44t	3
26	65-402-010	Washer, Lock #10	3
27	65-335-102-8	Screw, Socket Hd.#10-32 x 1/2	1
28	67-26185	Cushion Ring	3
29	54-26231	Bearing Adapter	3
30	67-26186	Bearing 20mm ID	3
31	54-26021-1	Tool Adaptor	3
32	65-26016	Setscrew, #8-32 X 7/64	6
33	65-335-86-16	Screw, Socket Hd. #6-32 x 1	2
34	54-H0213	Pen Holder	1
35	68-26027	Pen Assembly	1

ITEM	PART No.	DESCRIPTION	QTY
36	54-H0211	Pen Cradle	2
37	65-203-86	Nut, #6-32	2
38	54-H0349	Slide Connector, Pen Cylinder	1
39	65-410-060	Washer, Flat #6	1
40	65-333-86-16	Screw, Button Hd. #6-32 x 1	1
41	65-203-84	Nut #5-40	1
42	27-02996-1	Cushion Tube	3/8"
43	65-335-86-4	Screw, Socket Hd. #6-32 x 1/4	2
44	27-H0225	Cylinder Mount	1
45	65-332-75-6	Screw, Flat Hd. #2-56 x 3/8	4
46	54-H0212	Pen Mounting Plate	1
47	65-332-75-6	Screw, Flat Hd. #2-56 x 3/8	4
48	65-332-75-6	Screw, Flat Hd. #2-56 x 3/8	2
49	67-H0221-R	Linear Bearing, Pen	1
50	54-26301	Adapter Plate, Pen Mount	1
51	65-335-86-6	Screw, Socket Hd. #6-32 x 3/8	2
52	27-H0224	Pen Cylinder	1
53	27-H0250	Air Fitting, 10-32 tap x 5/32	1
54	31-26183	Washer & Nut, (Part of #57)	1
55	65-333-102-6	Screw, Button Hd. 10-32 x 3/8	6
56	65-410-010	Washer, Flat #10	6
57	31-26183	Prox Switch	1
58	31-03008-1	Cable, Prox Switch	1
59	67-26151	Pen Holder/Adapter	1
60	67-26152	Refill Ink Pen, Black	1
*	67-26152-1	Refill Ink Pen, Yellow (Optional)	
61	67-26151	Pen Holder/Adapter(Part of #59)	1
62	67-26150	Grip Tube	1
63	67-26187	Cover	1
64	65-409-99	Finish Washer, #10	4
65	65-333-102-8S	Screw, Button Hd. #10-32 x 1/2	4
66	67-26182	Tool Guard	1
67	65-355-44-6	Shoulder Bolt	6
**68	67-26163	Ball Driver. 9/64", 7" Long	1
**69	67-26174	T-Handle, 9/64", 6" Long	1
**70	67-26175	Hex Key, 5/64"	1
**71	67-26176	Hex key, 2.5 mm	1

* Not Included in Kit

**Not Shown

A/R - As Required

(A)	27-02996-1	Air Tubing, 1/4"	A/R
(B)	27-02996-2	Air Tubing, 5/32"	A/R

Refer to
Automated Cutting Tools Manual
E-515 for latest Available Tools



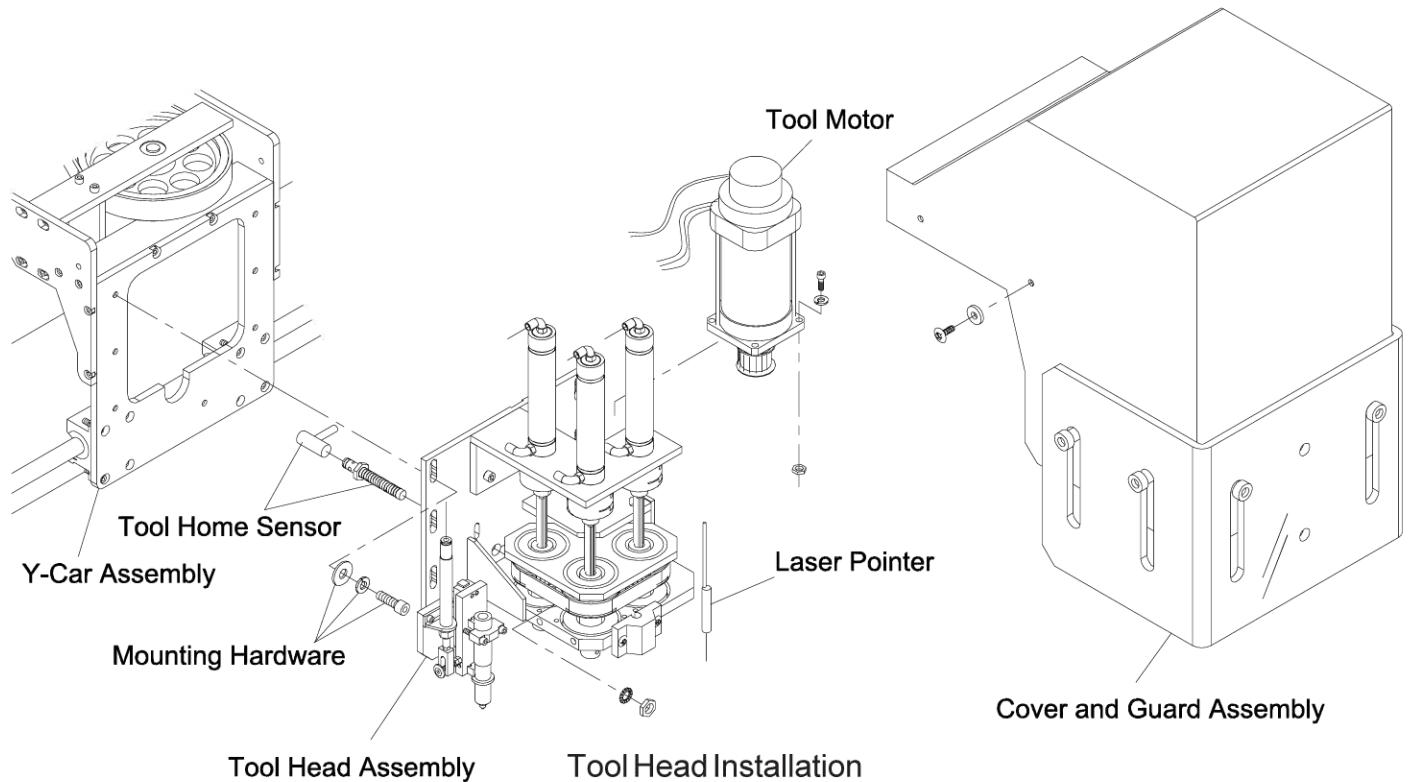

Tool Head Installation

1. Install tool home switch and connect cable.
2. Install tool head assembly to the y-car assembly.
3. Mount the laser pointer as shown.
4. Install the tool motor using caution not to over tension the drive belt.
5. Connect air tubing.
6. Install new cover and guard assembly.
7. Secure guard in upper position with bolt provided.
8. Mount new tools.
9. Reposition pen to normal operating position.
10. Remove guard locking screw.

The new tool head can now be calibrated and is ready for use.

Limited Warranty. Eastman warrants to the buyer that the equipment shall be free from defects in materials or workmanship for a period of 90 days commencing on the date of invoice. Any goods or parts claimed by the buyer to be defective must be returned to Eastman, freight charges prepaid, within the 90-day warranty period. If Eastman determines that the goods or parts are defective in materials or workmanship, Eastman's sole obligation under this warranty shall be, at Eastman's sole option, to repair or replace the defective goods or parts or to provide the buyer a credit equal to the portion of the purchase price allocable to the defective goods or parts. This warranty shall not apply if defects are caused by product misuse or neglect, if the machine has been altered or modified by the buyer, or if other than genuine Eastman belts, emery wheels, knives or parts are used in the machine. THIS WARRANTY IS THE ONLY WARRANTY APPLICABLE TO THIS PURCHASE. SELLER DISCLAIMS ALL OTHER WARRANTIES, EXPRESS OR IMPLIED, INCLUDING, BUT NOT LIMITED TO, THE IMPLIED WARRANTIES OF MERCHANTABILITY AND FITNESS FOR A PARTICULAR PURPOSE.

Limitation of Liability. Eastman's liability to the buyer, and the buyer's remedies from Eastman, whether in contract, negligence, tort, under any warranty or otherwise, shall be limited to the remedies provided in the foregoing Limited Warranty. In no event shall Eastman have any responsibility or liability to the buyer for (a) any special, indirect, incidental, or consequential damages, including, but not limited to, loss of use, revenue, or profit, even if Eastman has been advised of the possibility of such damages, or (b) any claim against the buyer by any third party. The price stated for the product sold is a consideration for limiting Eastman's liability.