



Finest Quality

# Union Special

INDUSTRIAL SEWING EQUIPMENT

## ADJUSTING INSTRUCTIONS/ ILLUSTRATED PARTS MANUAL

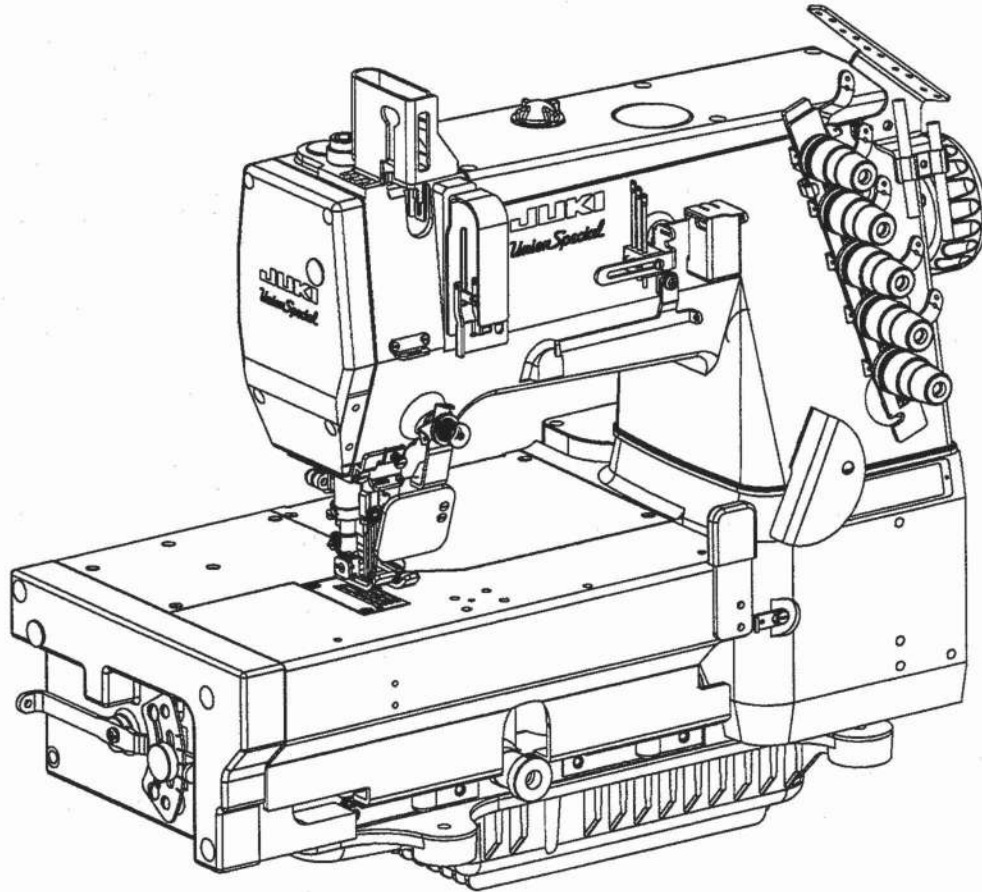

**FS300 SERIES, DIFFERENTIAL FEED,  
HIGH SPEED FLAT BED MACHINES**

**MANUAL NO. PT9616  
FOR DEVICES**

TC1FS3  
TC2FS3  
TC2AFS3  
TC3FS3  
TC4FS3

**Parts Manual PT9616  
for Devices TC1FS3, TC2FS3, TC2AFS3, TC3FS3, TC4FS3**

Second Edition Copyright 1997 by Union Special Corporation  
Rights Reserved In All Countries Printed in U.S.A. February 1997

**PREFACE**

This parts manual has been prepared to assist you in locating NEW individual parts or assemblies on the FS300 Series machines. It can be used in conjunction with Union Special Parts Manuals PT9501, PT9602 (depending on machine style) & Operator's Manual OP9423.

It is the desire of Union Special that each machine run at its optimum performance. Parts listed in this manual are designed specifically for your machine and are manufactured with utmost precision to assure long lasting service.

This manual has been comprised on the basis of available information. Changes in design and/or improvements may incorporate a slight modification of configuration in illustrations or part numbers.

---



## CONTENTS

•TC1FS3 MANUAL TAPE CUTTER & ADJUSTMENTS .....	5
•TC2FS3 PNEUMATIC TAPE CUTTER & ADJUSTMENTS .....	7
•TC2AFS3 PNEUMATIC TAPE CUTTER & ADJUSTMENTS .....	9
•TC3FS3 ELECTRIC TAPE CUTTER & ADJUSTMENTS .....	11
•TC4FS3 PNEUMATIC FAST ACTION TAPE CUTTER & ADJUSTMENTS .....	13
•TC1FS3, TC2AFS3, TC3FS3, TC4FS3 MISCELLANEOUS COVERS .....	15
•TC2FS3 MISCELLANEOUS COVERS .....	17
•TC2FS3, TC2AFS3, TC4FS3 PNEUMATIC CONTROLS .....	19
•TC3FS3 ELECTRIC CONTROLS .....	21
•TC2FS3, TC2AFS3 TUBING .....	22
•TC3FS3 TUBING .....	23
•TC4FS3 TUBING .....	24
•NUMERICAL INDEX OF PARTS .....	25
•NOTES .....	26
•NOTES .....	27



Add 1 drop of oil once a week to oil holes shown.

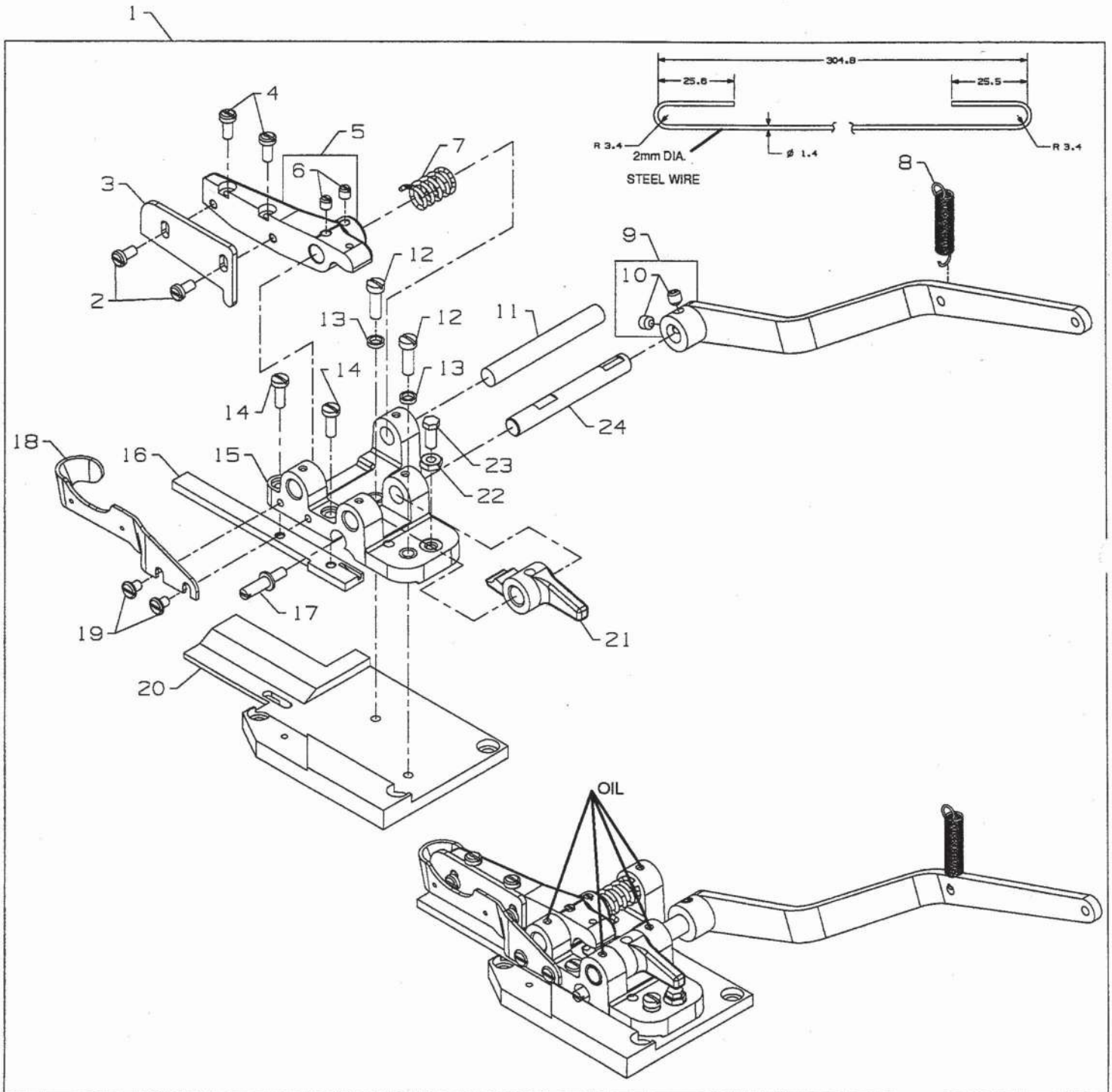

## TC1FS3 MANUAL TAPE CUTTER & ADJUSTMENTS

Ref. No.	Part No.	Description	Amt. Req.
1.	29486AF	Tape Cutter Assembly .....	1
2.	22528	Screw .....	2
3.	52875D	Upper Knife .....	1
4.	93	Screw .....	2
5.	50372	Knife Holder .....	1
6.	95	Screw .....	2
7.	52875G	Spring .....	1
8.	51283G	Spring .....	1
9.	50367K	Operating Lever .....	1
10.	22651CD4	Screw .....	2
11.	52875F	Shaft .....	1
12.	136	Screw .....	2
13.	21212	Spacer .....	2
14.	22596	Screw .....	2
15.	50383T	Frame .....	1
16.	50349D	Lower Knife .....	1
17.	15447A	Adjusting Screw .....	1
18.	50396E	Upper Knife Guard .....	1
19.	22829	Screw .....	2
20.	50383AB	Mounting Plate .....	1
21.	50367L	Actuating Lever .....	1
22.	12538	Nut .....	1
23.	22852	Screw .....	1
24.	50322AP	Shaft .....	1

### KNIFE ADJUSTING PROCEDURE:

1. Remove guard (18).
2. Loosen nut (22).
3. Turn screw (23) the knife holder (5) to create a .5mm (.020") overlap at the left end, when fully acuated.
4. Hold screw (23) and tighten nut (22). Actuate to check the setting.
5. Adjust the shear angle, loosen right screw (14) and rotate adjusting screw (17) so left ends of knives are touching, and there is a .001" to .0025" clearance between knives at the right end, tighten screw (14).
6. Replace guard before using.



TC2 Pneumatic Tape Cutter is activated by using the Pneumatic Knee Switch. Set filter regulator to a maximum of 60 P.S.I. Add 1 drop of oil once a week to the oil holes shown.

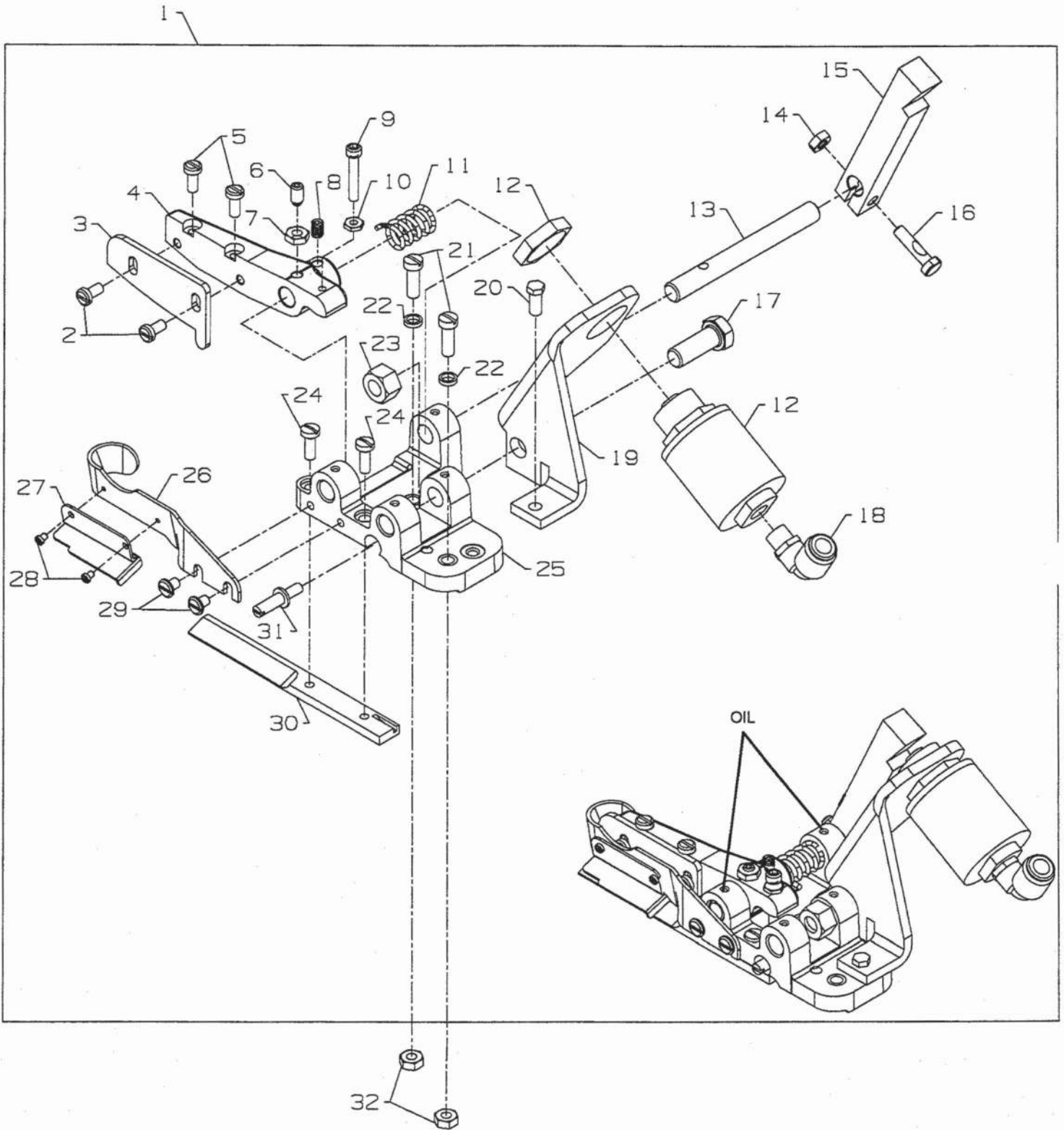

## TC2FS3 PNEUMATIC TAPE CUTTER & ADJUSTMENTS

Ref. No.	Part No.	Description	Amt. Req.
1.	29486AE	Pneumatic Tape Cutter Assembly .....	1
2.	22528	Screw .....	2
3.	52875R	Upper Knife .....	1
4.	50372	Knife Holder .....	1
5.	93	Screw .....	2
6.	22894H	Screw .....	1
7.	12538	Nut .....	1
8.	22894J	Screw .....	1
9.	22652A16	Cap Screw .....	1
10.	NU12	Hex Nut .....	1
11.	52875G	Shaft Spring .....	1
12.	671A2	Tape Cutter Air Cylinder .....	1
13.	52875U	Tape Cutter Shaft .....	1
14.	18	Nut .....	1
15.	52875T	Blade Actuating Arm .....	1
16.	55244G	Screw .....	1
17.	22604	Screw .....	1
18.	671F79	Elbow Fitting .....	1
19.	52875S	Air Cylinder .....	1
20.	22852	Screw .....	1
21.	136	Screw .....	2
22.	21212	Spacer .....	2
23.	11698L	Nut .....	1
24.	22596	Screw .....	2
25.	50383T	Frame .....	1
26.	52857H	Knife Guard .....	1
27.	52875J	Cloth Guide .....	1
28.	604	Screw .....	2
29.	22829	Screw .....	2
30.	52875C	Lower Knife .....	1
31.	15447A	Screw .....	2
32.	18	Nut .....	2

### KNIFE ADJUSTING PROCEDURE:

1. Remove guard (26) and guide (27).
2. Loosen locking nut (14) on blade acuating arm (15) and nut (10) on screw (9).
3. Set the maximum opening between the knives to be 20-21mm, by rotating screw (9) to achieve the proper opening. Holding knife holder (4) and screw at the maximum opening, tighten nut (10).
4. Lower knife holder (4), creating a .5mm (.020") overlap at the left end. Holding this position, actuate the air cylinder and bring blade actuating arm into contact with the plunger, tighten nut (10).
5. Adjust the shear angle, loosen right screw (24) and rotate adjusting screw (31) so the left ends of the knives are touching, and there is a .001" to .0025" clearance between knives at the right end, tighten screw (24).
6. Hook up the solenoid and test with material, the unit must be able to cut the full length of the knives.
7. Replace all guards before using.



TC2A Pneumatic Tape Cutter is activated by using the Pneumatic Knee Switch. Set filter regulator to a maximum of 60 P.S.I. Add 1 drop of oil once a week to the oil holes shown.

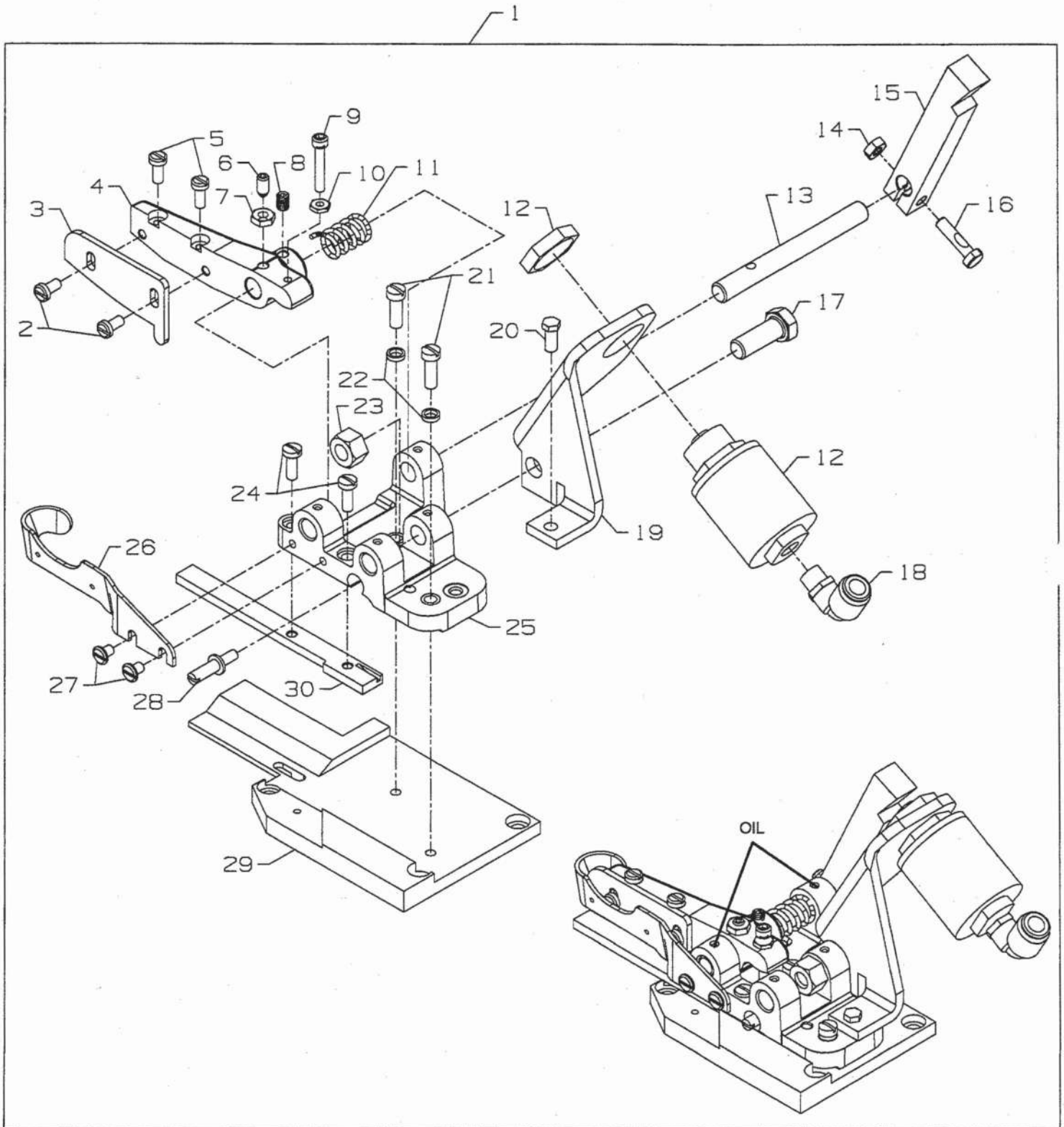



## TC2AFS3 PNEUMATIC TAPE CUTTER & ADJUSTMENTS

Ref. No.	Part No.	Description	Amt. Req.
1.	29486AG	Pneumatic Tape Cutter .....	1
2.	22528	Screw .....	2
3.	52875R	Upper Knife .....	1
4.	50372	Knife Holder .....	1
5.	93	Screw .....	2
6.	22894H	Screw .....	1
7.	12538	Nut .....	1
8.	22894J	Set Screw .....	1
9.	22652A16	Screw .....	1
10.	NU12	Nut .....	1
11.	52875G	Spring .....	1
12.	671A2	Tape Cutter Air Cylinder .....	1
13.	52875U	Tape Cutter Shaft .....	1
14.	18	Hex Nut .....	1
15.	52875T	Blade Actuating Arm .....	1
16.	55244G	Screw .....	1
17.	22604	Screw .....	1
18.	671F79	5/16 Elbow Fitting .....	1
19.	52875S	Cylinder Mounting .....	1
20.	22852	Screw .....	1
21.	136	Screw .....	2
22.	21212	Spacer .....	2
23.	11698L	Nut .....	1
24.	22596	Screw .....	2
25.	50383T	Frame .....	1
26.	50396E	Knife Guard .....	1
27.	22829	Screw .....	2
28.	15447A	Adjusting Screw .....	1
29.	50383AB	Mounting Plate .....	1
30.	50349D	Lower Knife .....	1

### KNIFE ADJUSTING PROCEDURE:

1. Remove guard (26).
2. Loosen nuts for blade actuator arm (15) and nut (10) on screw (9).
3. Set the maximum opening between the knives to be 20-21mm, by rotating screw (9) to achieve the proper opening. Holding knife holder (4) and screw (9) at the maximum opening, tighten nut (10).
4. Lower knife holder (4), creating a .5mm (.020") overlap at the left end. Holding this position, actuate the air cylinder and bring the blade actuating arm (15) into contact with the plunger, tighten nut (10).
5. Adjust the shear angle, loosen the right screw (24) and rotate adjusting screw (28) so the left ends of the knives are touching, and there is a .001" to .0025" clearance between knives at the right end, retighten screw (24).
6. Hook up the solenoid and test with material, the unit must be able to cut the full length of the knives.
7. Replace guard before using.



TC3 Electric Tape Cutter is activated by using the Electric Knee Switch. Add 1 drop of oil once a week to the oil holes shown.

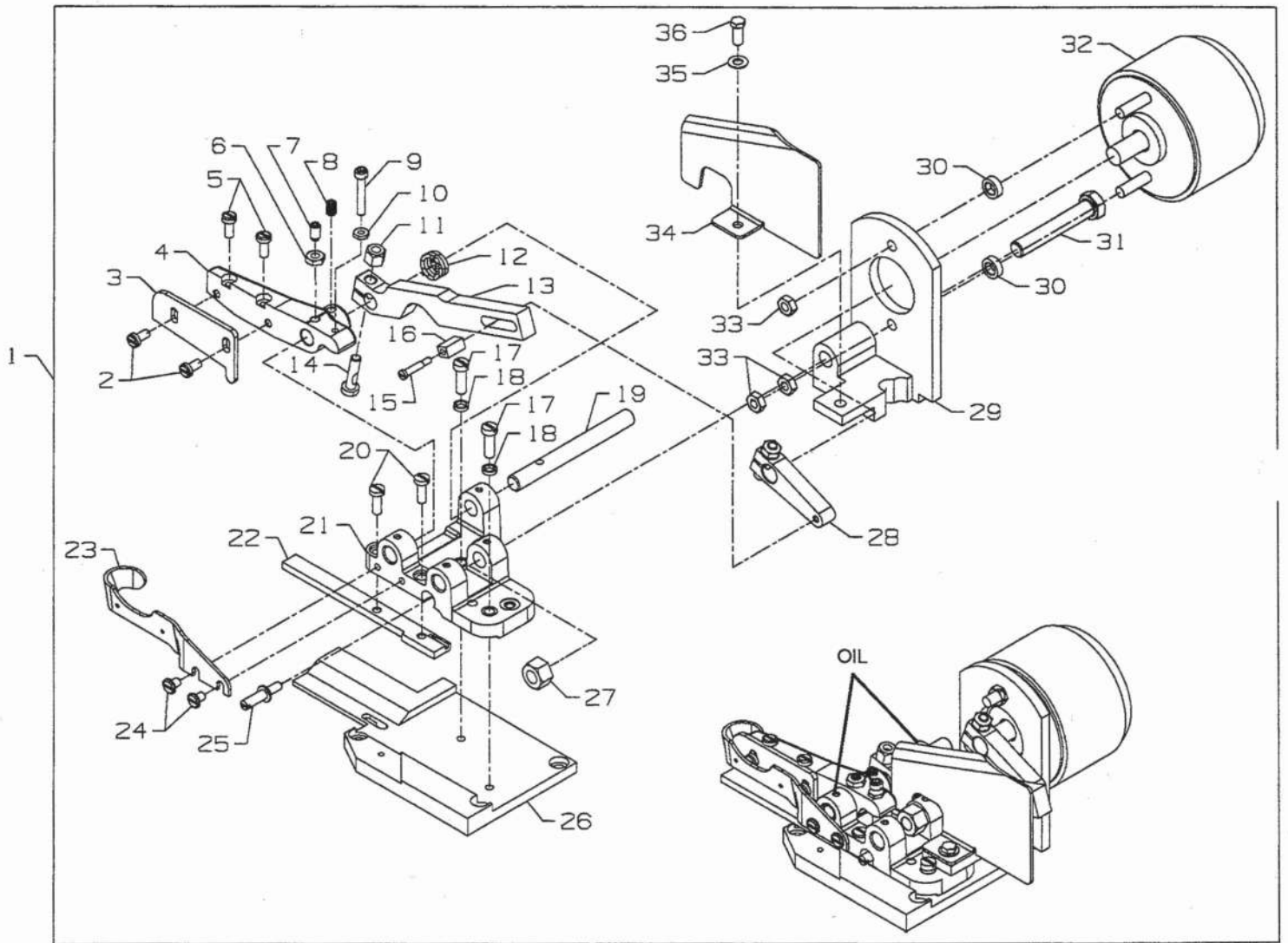

## TC3FS3 ELECTRIC TAPE CUTTER & ADJUSTMENTS

Ref. No.	Part No.	Description	Amt. Req.
1.	29486AD	Tape Cutter Assembly .....	1
2.	22528	Screw .....	2
3.	52875D	Upper Knife .....	1
4.	50372	Knife Holder .....	1
5.	93	Screw .....	2
6.	12538	Nut .....	1
7.	22894H	Screw .....	1
8.	22894J	Screw .....	1
9.	22652A16	Cap Screw .....	1
10.	NU12	Hex Nut .....	1
11.	HA18A	Nut .....	1
12.	503756	Return Spring .....	1
13.	50375H	Actuator Lever .....	1
14.	55244G	Locking Stud .....	1
15.	22793	Screw .....	1
16.	50375K	Slider Block .....	1
17.	136	Screw, for mounting plate .....	2
18.	21212	Spacer, for mounting plate .....	2
19.	52875U	Tape Cutter Shaft .....	1
20.	22596	Screw .....	2
21.	50383T	Frame .....	1
22.	50349D	Lower Knife .....	1
23.	50396E	Upper Knife Guard .....	1
24.	22829	Screw .....	1
25.	15447A	Screw .....	1
26.	50383AB	Mounting Plate .....	1
27.	11698L	Nut .....	1
28.	50375J	Drive Lever .....	1
29.	50383U	Bracket .....	1
30.	51134J	Washer .....	2
31.	22640M144	Screw .....	1
32.	670K25	Rotary Solenoid .....	1
33.	RM3211-1	Hex Nut .....	3
34.	50375N	Mechanism Guard .....	1
35.	40-139	Washer .....	1
36.	22852	Screw .....	1

### KNIFE ADJUSTING PROCEDURES:

1. Remove guard (23).
2. Loosen nut for lever (28) and lever (13). Loosen nut (10) on screw (9).
3. Place a 3.2mm (.125") spacer between knife holder (4) and lever (13).
4. Set the maximum opening between knives to be 20-21mm, by rotating screw (9) to achieve the proper opening. Holding the lever (13) and screw (9) at the maximum opening, retighten nut (10).
5. Lower knife holder (4), creating a .5mm (.020") overlap at the left end. Holding this position, set the slider block (16) so it is approximately .5mm (.020") above the center of the lower radii in the slot of lever (13), tighten nut (11). Remove spacer.
6. Slide lever (28) in or out, so as to position the front of the slider block (16) even with or .25mm (.010") beyond the front of lever (13), retighten nut.
7. Adjust the shear angle, loosen the right screw (20) and rotating screw (25) so the left ends of the knives are touching, and there is a .001" to .0025" clearance between knives at the right end, tighten screw (20).
8. Hook up the solenoid and test with material, the unit must be able to cut the full length of the knives.
9. Replace guard before using.



TC4 Pneumatic Fast Action Tape Cutter is activated by using the Pneumatic Knee Switch.

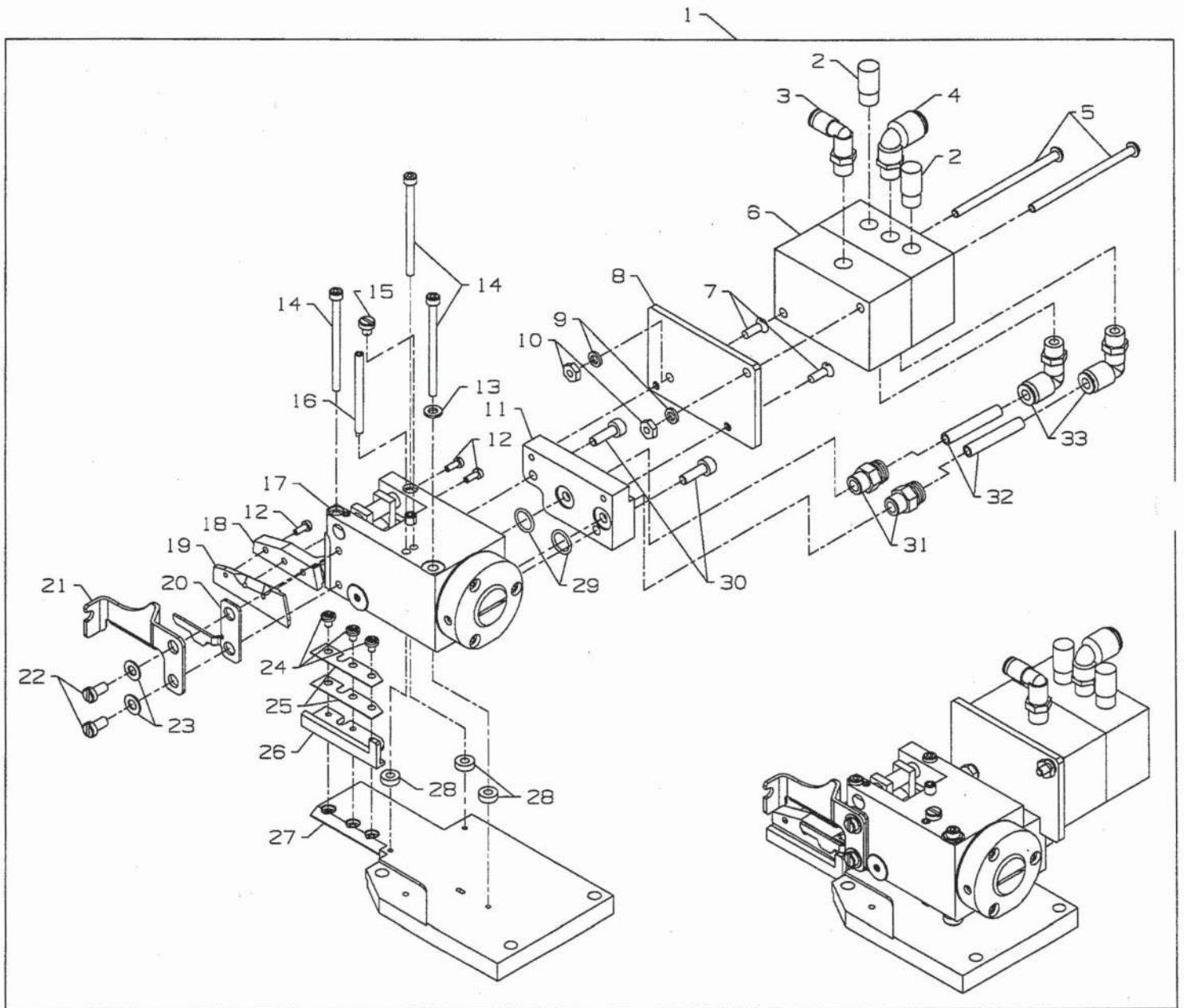

## TC4FS3 PNEUMATIC FAST ACTION TAPE CUTTER & ADJUSTMENTS

Ref. No.	Part No.	Description	Amt. Req.
1.	29933CB	Pneumatic Fast Action Tape Cutter Assembly.....	1
2.	660-403	Muffler.....	2
3.	671F82C	Male "L".....	1
4.	671F79	Elbow Fitting.....	1
5.	RM4412-1	Round Head.....	2
6.	671-86	Binary Count.....	1
7.	22637N32	Ft. Hd. Screw.....	1
8.	56382AR	Bracket.....	1
9.	RM3993-3	Washer.....	2
10.	660-602	#10-24 Hex Nut.....	2
11.	56382AS	Manifold.....	1
12.	99343D	Screw.....	3
13.	8372A	Washer.....	1
14.	95409A	Screw.....	3
15.	95169	Screw.....	1
16.	99702E	Eccentric Bolt.....	1
17.	29933C	Tape Clip.....	1
18.	99701CA	Knife Lever.....	1
19.	99670MC	Upper Knife.....	1
20.	99682NC	Finger Guard.....	1
21.	99682ND	Finger Guard.....	1
22.	95157	Screw.....	2
23.	20	Washer.....	2
24.	22513D	Screw.....	3
25.	99702DA	Shim.....	2
26.	99669MC	Lower Knife.....	1
27.	50373CK	Base Plate.....	1
28.	99702GA	Spacer.....	3
29.	999-93	Round Belt - "O" Ring.....	2
30.	95403A	Screw.....	1
31.	671F81D	Connector.....	2
32.	671B37B	Nylon Tubing.....	1
33.	671F81C	Elbow.....	2

### KNIFE ADJUSTING PROCEDURES:

1. Remove guards (19) and (20).
2. Loosen screws (14) slightly.
3. Manually activate until knife lever (18) is in its lowest position. Cutting edges of upper knife (19) and lower knife (25) should overlap approximately .5mm (.020).
4. Remove screw (15) and rotate eccentric bolt (16) until knives just contact at knife tips and .03mm (.0012) arises at lower knife (26). Tighten screw (14) while holding eccentric bolt (16) so it does not turn. Replace screw (15).
5. Replace guards before using.



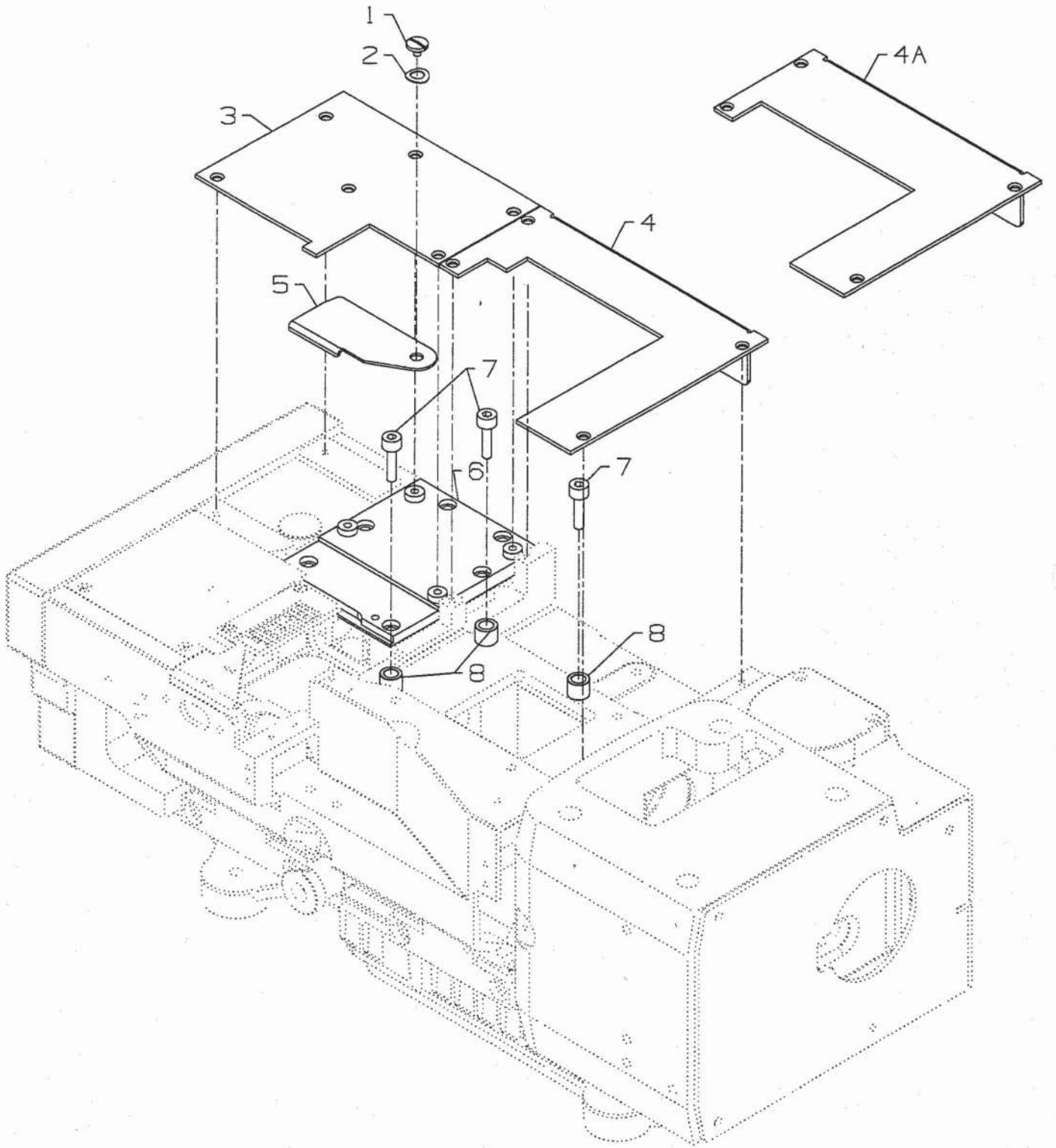

TC1FS3, TC2AFS3, TC3FS3, TC4FS3 MISCELLANEOUS COVERS

Ref. No.	Part No.	Description	Amt. Req.
1.	22726	Screw, for swing plate .....	1
2.	95978	Washer, for swing plate .....	1
3.	50301BC	Cloth Plate, left .....	1
4.	50301CL	Cloth Plate, right, for TC1, TC2A, TC3 .....	1
4A.	50301BD	Cloth Plate, right, for TC4 .....	1
5.	50332N	Swing Plate .....	1
6.	50382GP	Cover, feed chamber.....	1
7.	99371B	Screw .....	3
8.	34886FB	Spacer .....	3



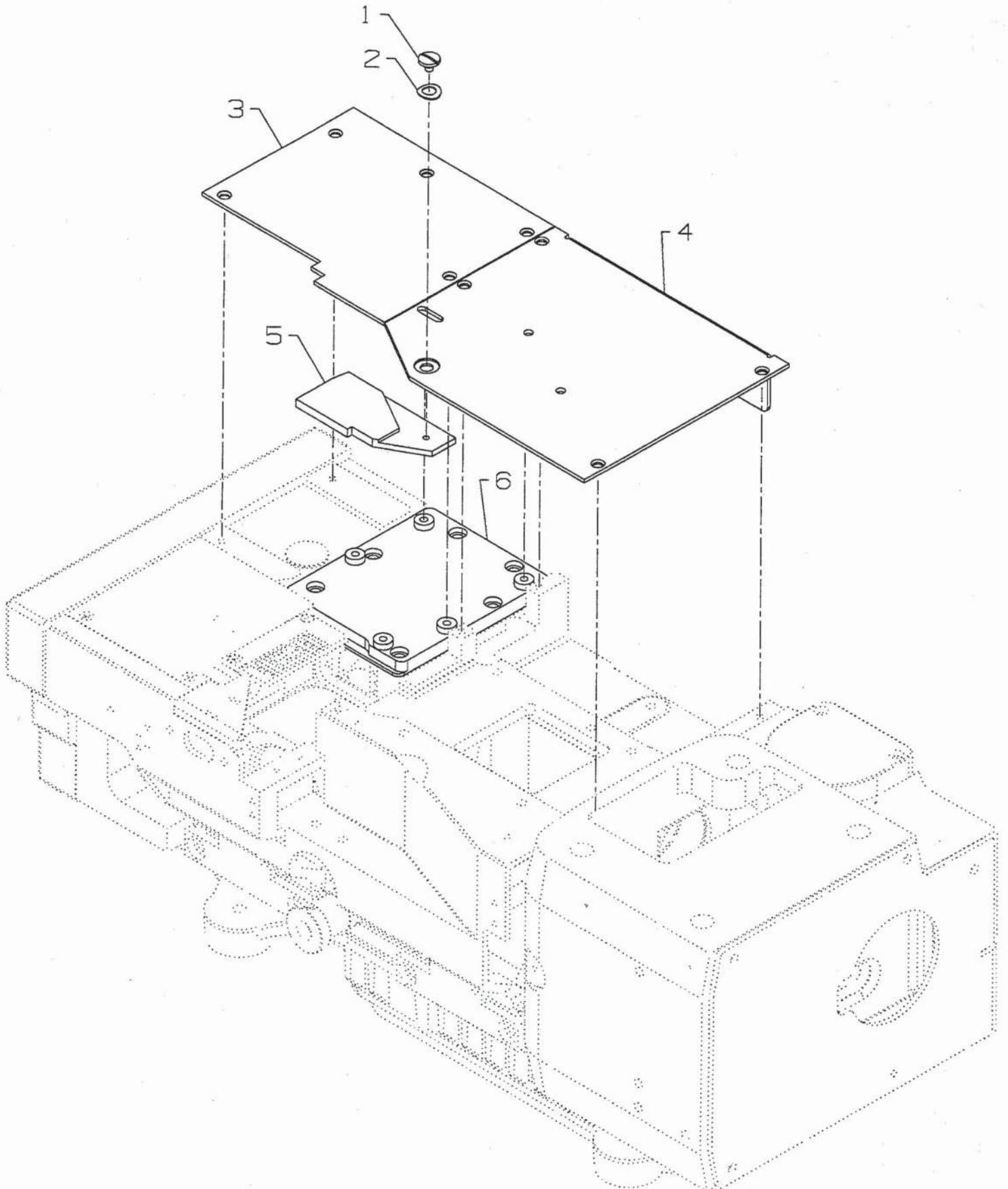



### TC2FS3 MISCELLANEOUS COVERS

Ref. No.	Part No.	Description	Amt. Req.
1.	22726	Screw .....	1
2.	95978	Washer .....	1
3.	50301BU	Cloth Plate, Left .....	1
4.	50301BT	Cloth Plate, Right .....	1
5.	50345U	Swing Plate .....	1
6.	50382CP	Feed Chamber Cover .....	1



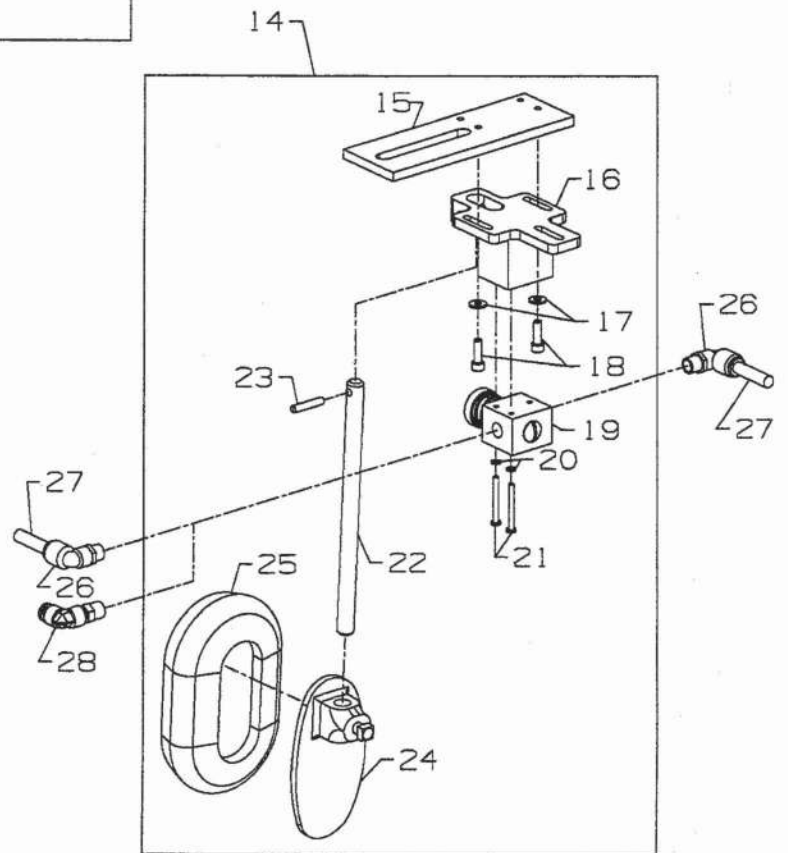
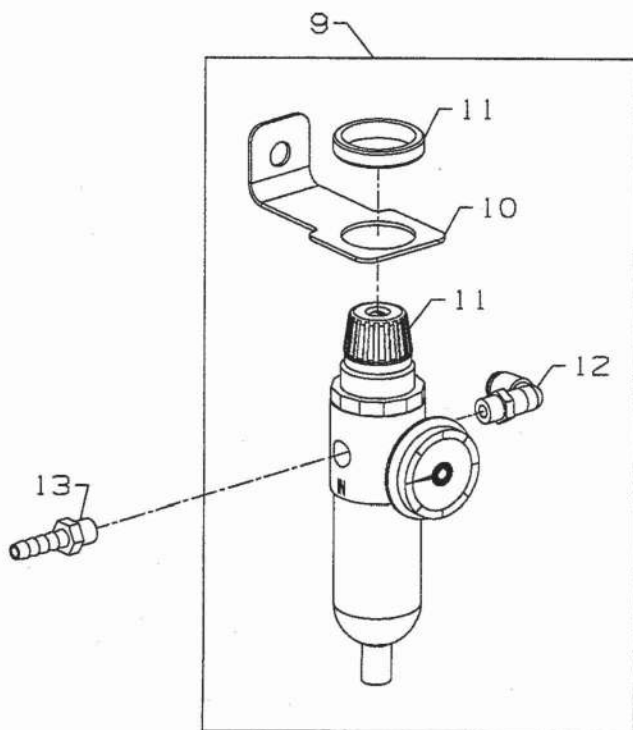
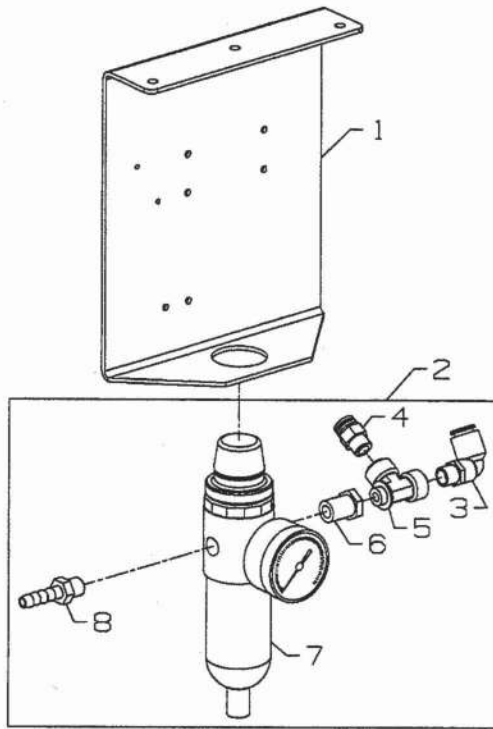

TC2FS3, TC2AFS3, TC4FS3 PNEUMATIC CONTROLS

Ref. No.	Part No.	Description	Amt. Req.
1.	99683CP	Mounting Bracket, for TC4 .....	1
2.	29480AWF	Pneumatic Control Assembly, for TC4 .....	1
3.	671F79	Elbow Fitting .....	1
4.	671F81D	Connector .....	1
5.	RM2850D	Tee .....	1
6.	671F6	Bushing .....	1
7.	671D42	Filter Regulator .....	1
8.	671F88	Barb Fitting .....	1
9.	29480ZA	Pneumatic Control Assembly, for TC2 and TC2A .....	1
10.	39583A	Mounting Bracket .....	1
11.	671D31	Filter Regulator .....	1
12.	671F79	Elbow Fitting .....	1
13.	671F1	Barb Fitting .....	1
14.	29480AWN	Knee Press Fitting .....	1
15.	50364H	Mounting Plate .....	1
16.	AS7-2	Knee Press Base .....	1
17.	RM3293-5	Flat Washer .....	2
18.	22653B10	Screw .....	2
19.	671-85	3-Way Valve Assembly .....	1
20.	96902	Washer .....	2
21.	90561K	Wood Screw .....	2
22.	AS7-1	Knee Press Rod .....	1
23.	667C16	Dowel Pin .....	1
24.	AS7-3	Knee Press .....	1
25.	660-168	Knee Press Pad .....	1
26.	671F79	Elbow Fitting .....	1/2
27.	67B38	Tubing .....	1/2
28.	671F82C	Elbow Fitting, for TC4 .....	1



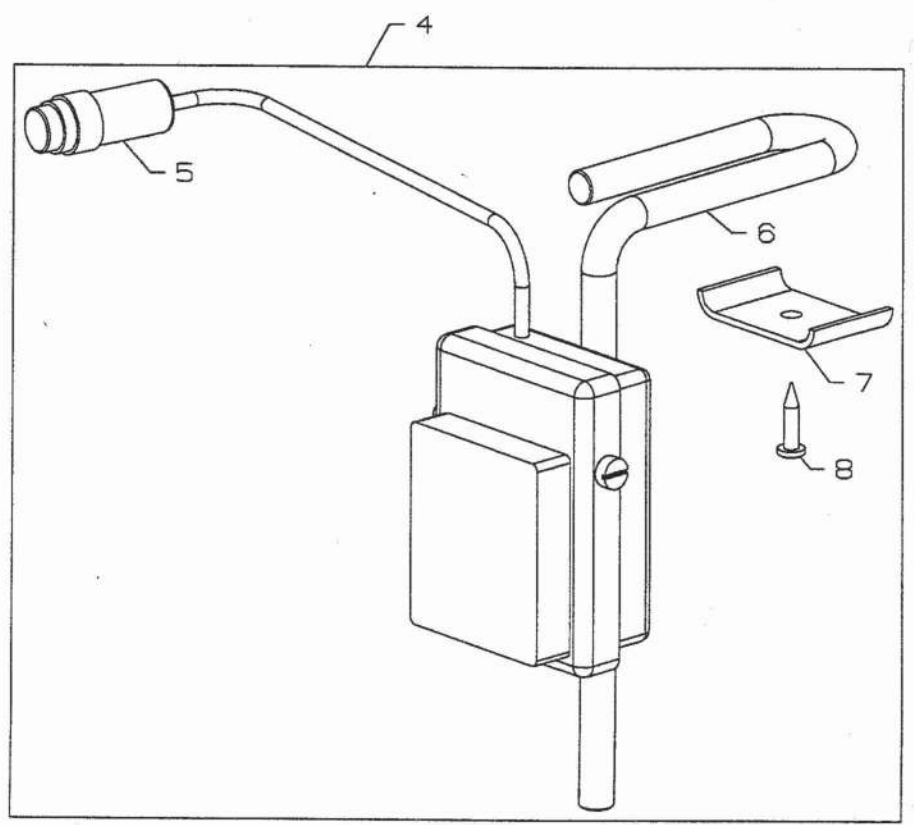
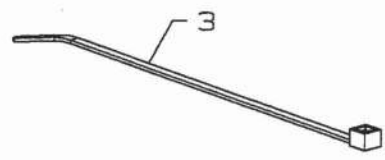
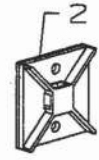
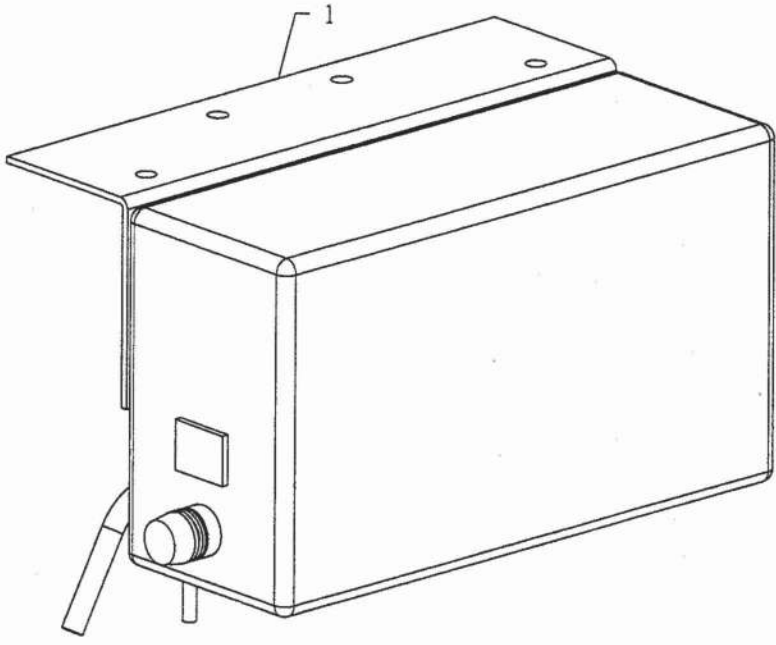

## TC3FS3 ELECTRIC CONTROLS

Ref. No.	Part No.	Description	Amt. Req.
1.	670L41	Control Box .....	1
2.	660-870	Bundling Strap.....	6
3.	RM2871B	Cable Tie.....	6
4.	998-338A	Knee Press.....	1
5.	998-387M	Plug.....	1
6.	998-147C	Holder Rod.....	1
7.	998-147D	Clamp.....	1
8.	90561Q	Wood Screw.....	1



# TC2FS3, TC2AFS3 TUBING

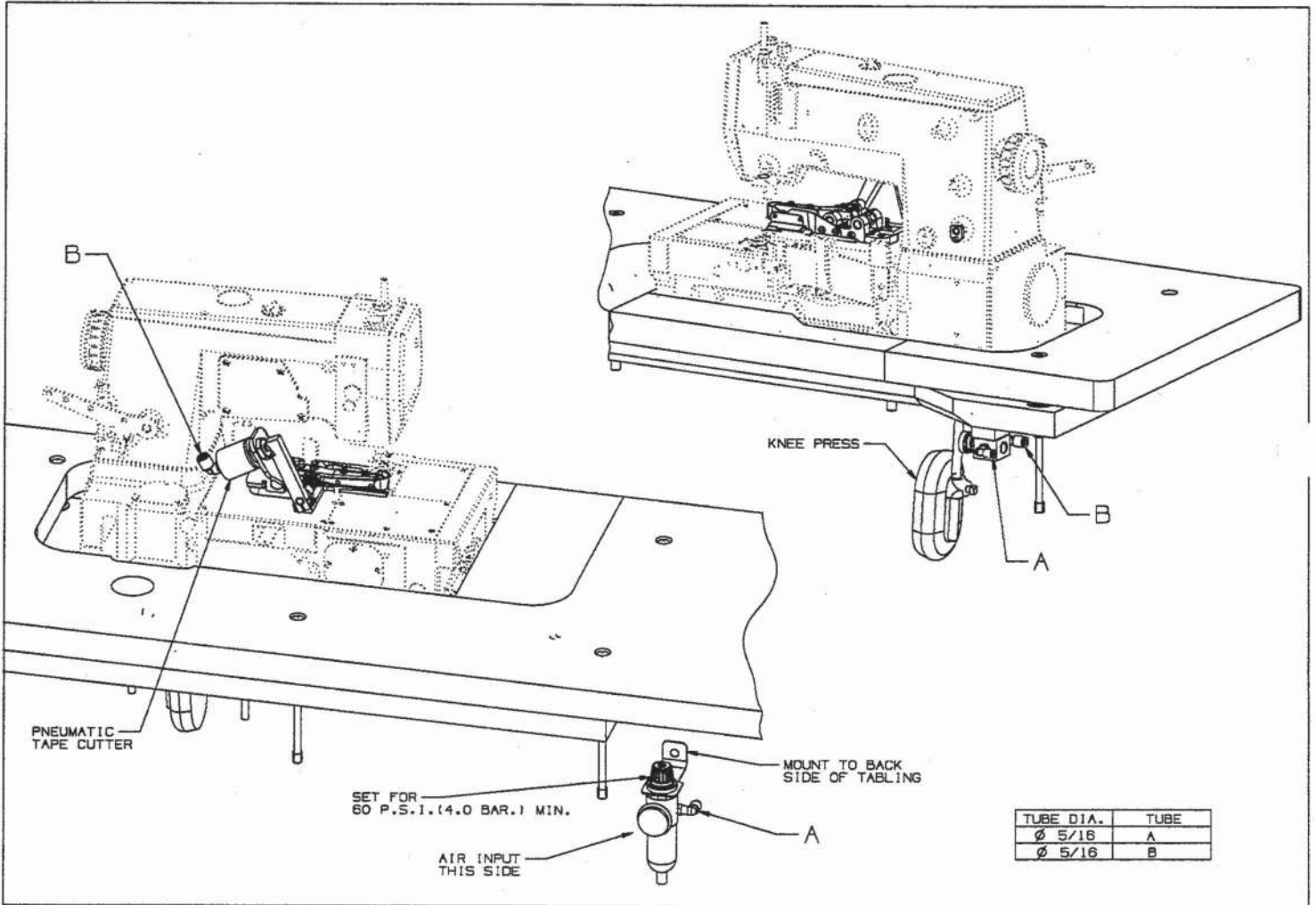

# TC3FS3 TUBING

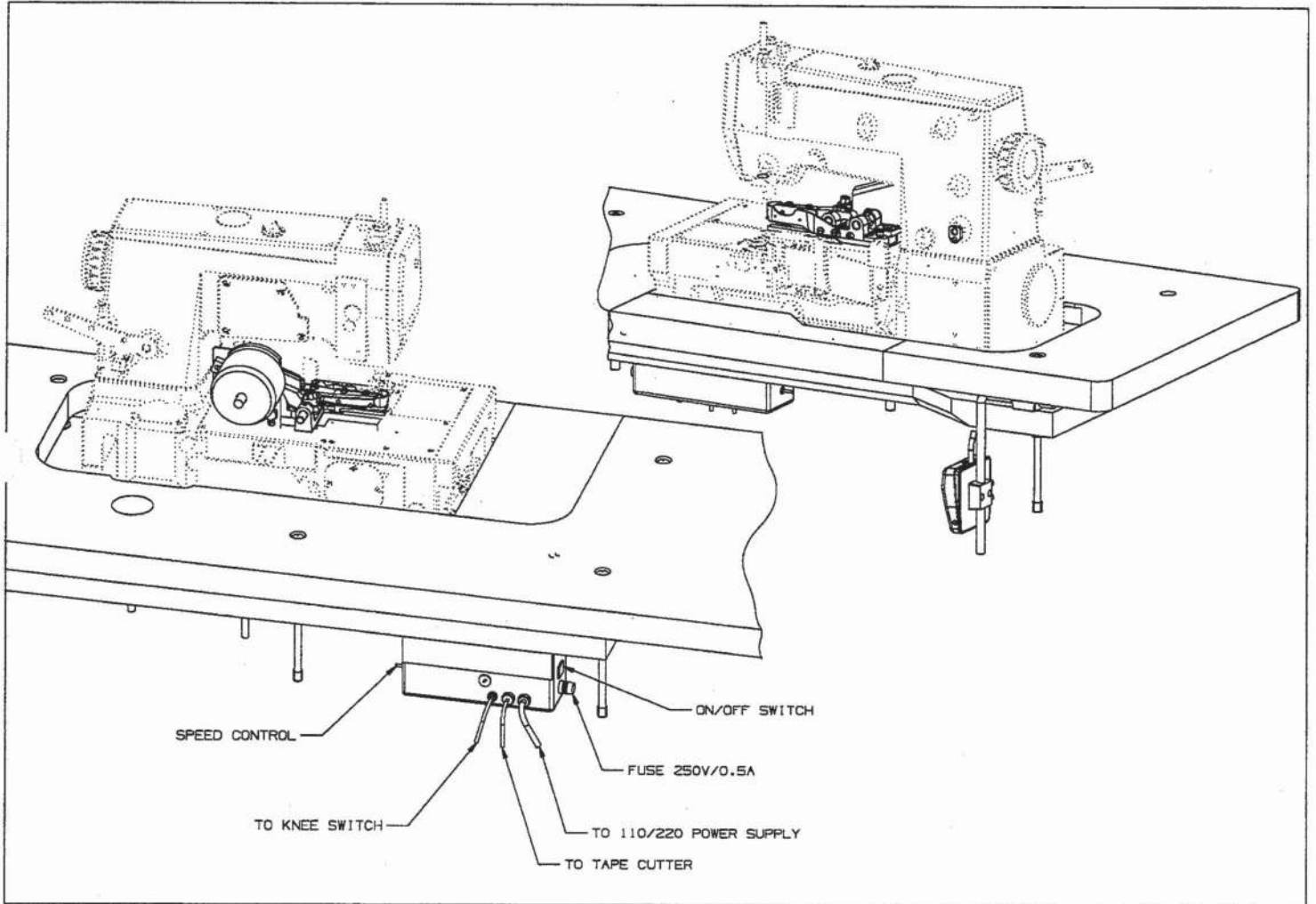

# TC4FS3 TUBING

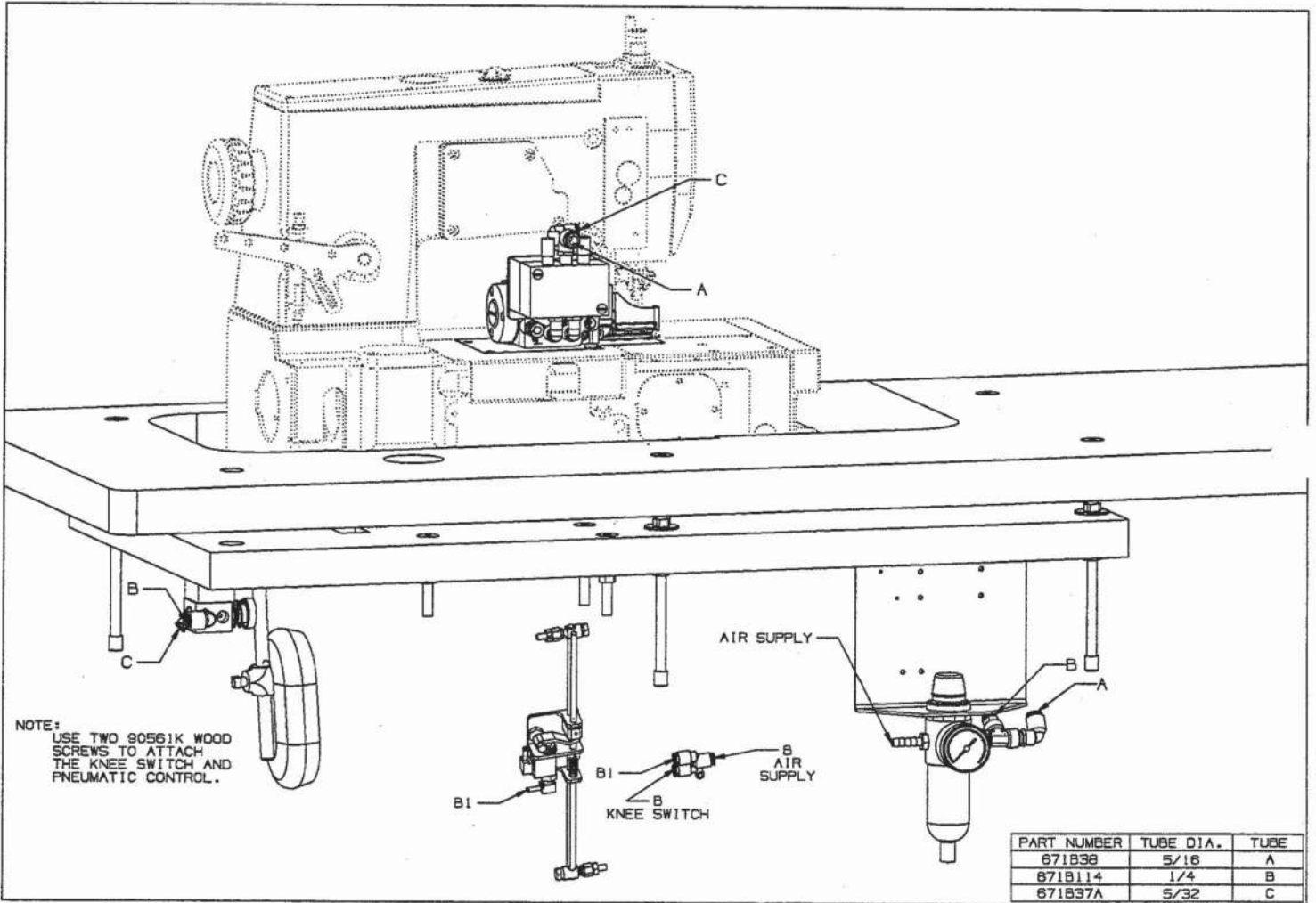



## NUMERICAL INDEX OF PARTS

<u>Part No.</u>	<u>Page No.</u>
11698L .....	7, 9, 11
12538 .....	5, 7, 9, 11
136 .....	5, 7, 9, 11
15447A .....	5, 7, 9, 11
18 .....	7, 9
20 .....	13
21212 ...	5, 7, 9, 11
22513D .....	13
22528 ...	5, 7, 9, 11
22596 ...	5, 7, 9, 11
22604 .....	7, 9
22637N32 .....	13
22640M144 .....	11
22651CD4 .....	5
22652A16 ...	7, 9, 11
22653B10 .....	19
22726 .....	15, 17
22793 .....	11
22829 ...	5, 7, 9, 11
22852 ...	5, 7, 9, 11
22894H ...	7, 9, 11
22894J ...	7, 9, 11
29480AWF .....	19
29480AWN .....	19
29480ZA .....	19
29486AD .....	11
29486AE .....	7
29486AF .....	5
29486AG .....	9
29933C .....	13
29933CB .....	13
29980LB .....	11
34886FB .....	15
39583A .....	19
40-139 .....	11
50301BC .....	15
50301BD .....	15
50301BT ...	15, 17
50301BU ...	15, 17
50301CL .....	15
50322AP .....	5
50332N .....	15
50345U .....	15, 17
50349D ...	5, 9, 11
50364H .....	19
50367K .....	5
50367L .....	5
50372 ...	5, 7, 9, 11
50373CK .....	13
503756 .....	11

<u>Part No.</u>	<u>Page No.</u>
50375H .....	11
50375J .....	11
50375K .....	11
50375N .....	11
50382CP ...	15, 17
50382GP .....	15
50383AB ...	5, 9, 11
50383T ...	5, 7, 9, 11
50383U .....	11
50396E ...	5, 9, 11
51134J .....	11
51283G .....	5
52857H .....	7
52875C .....	7
52875D ...	5, 11
52875F .....	5
52875G ...	5, 7, 9
52875J .....	7
52875R .....	7, 9
52875S .....	7, 9
52875T .....	7, 9
52875U ...	7, 9, 11
55244G ...	7, 9, 11
56382AR .....	13
56382AS .....	13
604 .....	7
660-168 .....	19
660-403 .....	13
660-602 .....	13
660-870 .....	21
667C16 .....	19
670K25 .....	11
670L41 .....	21
671-85 .....	19
671-86 .....	13
671A2 .....	7, 9
671B37B .....	13
671D31 .....	19
671D42 .....	19
671F1 .....	19
671F6 .....	19
671F79 ...	7, 9, 13, 19
671F81C .....	13
671F81D ...	13, 19
671F82C ...	13, 19
671F88 .....	19
67B38 .....	19
8372A .....	13
90561K .....	19
90561Q .....	21

<u>Part No.</u>	<u>Page No.</u>
92121 .....	7
93 ...	5, 7, 9, 11
95 .....	5
95157 .....	13
95169 .....	13
95403A .....	13
95409A .....	13
95978 ...	15, 17
96902 .....	19
99343D .....	13
99371B .....	15
99669MC .....	13
99670MC .....	13
99682NC .....	13
99682ND .....	13
99683CP .....	19
99701CA .....	13
99702DA .....	13
99702E .....	13
99702GA .....	13
998-147C .....	21
998-147D .....	21
998-338A .....	21
998-387M .....	21
999-93 .....	13
AS7-1 .....	19
AS7-2 .....	19
AS7-3 .....	19
HA18A .....	11
NU12 .....	7, 9, 11
RM2850D .....	19
RM2871B .....	21
RM3211-1 .....	11
RM3293-5 .....	19
RM3993-3 .....	13
RM4412-1 .....	13







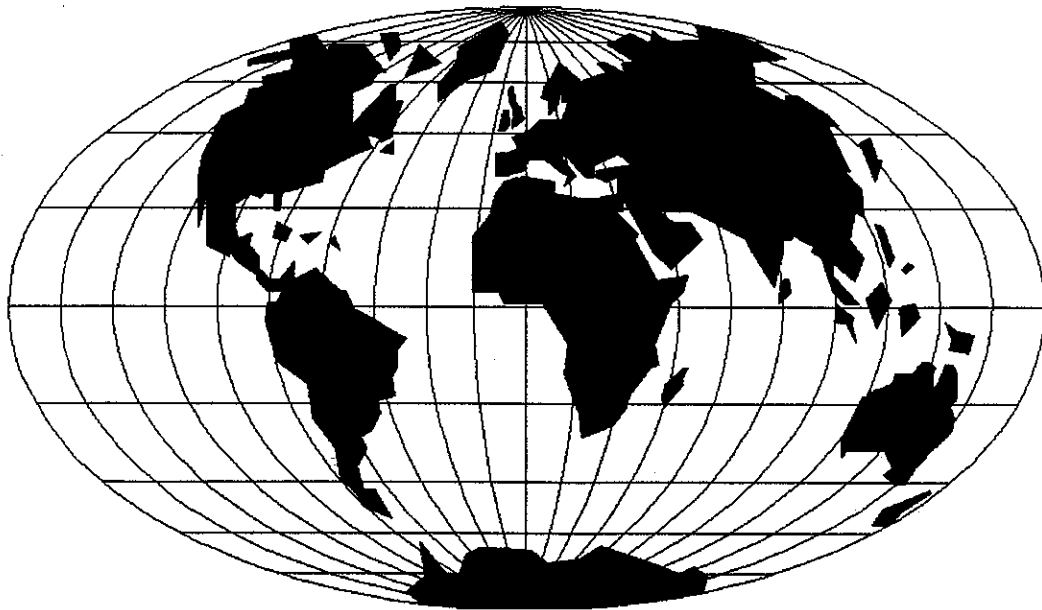

## WORLDWIDE SALES AND SERVICE

Union Special Corporation maintains sales and service facilities throughout the world. These offices will aid you in the selection of the right sewing equipment for your particular operation. Union Special Corporation representatives and service technicians are factory trained and are able to serve your needs promptly and efficiently. Whatever your location, there is a qualified representative to serve you.

---

Brussels, Belgium  
Charlotte, N.C.  
El Paso, TX  
Hong Kong, China  
Huntley, IL  
Leicester, England  
Lille, France  
Miami, FL  
Milan, Italy  
Möglingen, Germany  
Montreal, Quebec  
Osaka, Japan  
Santa Fe Springs, CA

Other Representatives throughout  
all parts of the world.



*Union Special*  
INDUSTRIAL SEWING EQUIPMENT