

# DDL-5550N-3,-7 NO.1

**JUKI**

High Speed 1-Needle Lockstitch Industrial Sewing Machine with Automatic Thread Trimmer

## DDL-5550N-3 DDL-5550N-7 Series PARTS LIST

29121506  
No.0918-04

### 1. MACHINE FRAME & MISCELLANEOUS COVER COMPONENTS

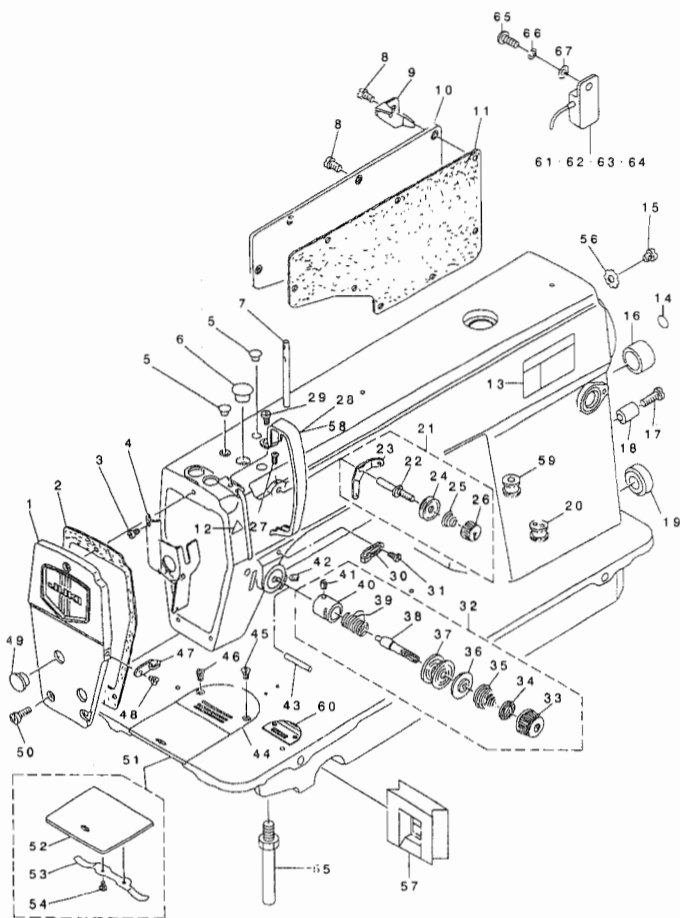

### 2. MAIN SHAFT COMPONENTS

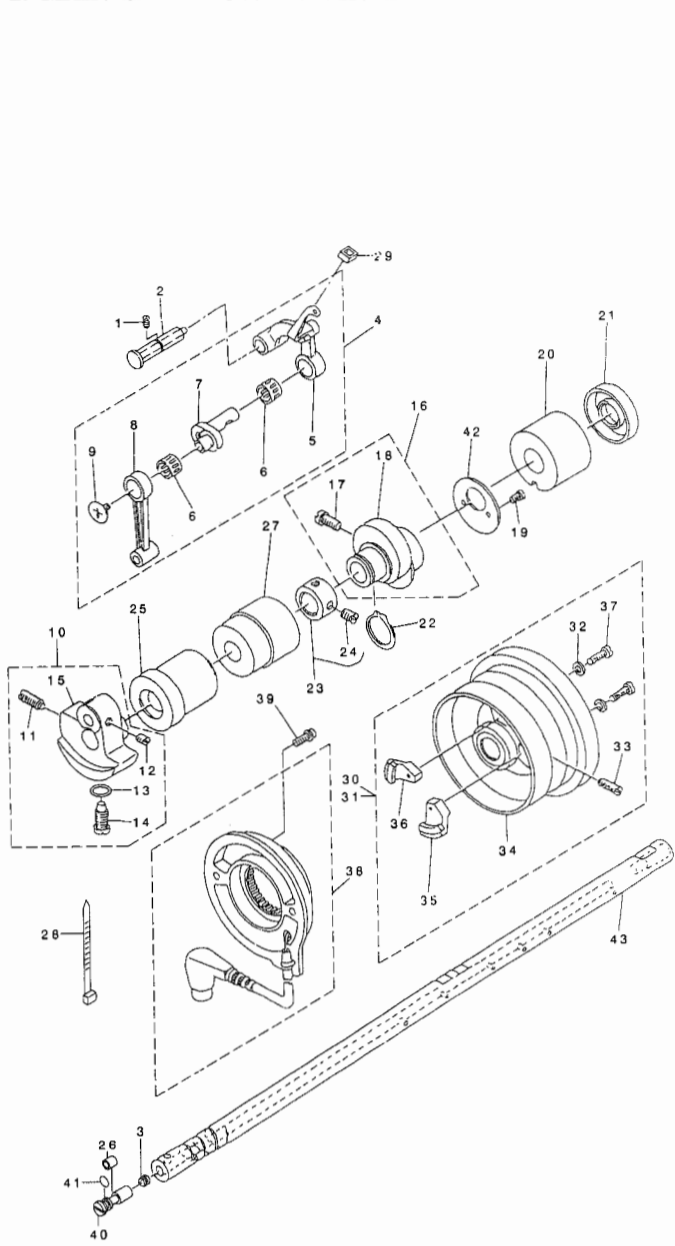

### 3. NEEDLE BAR, UPRIGHT SHAFT & HOOK DRIVING SHAFT COMPONENTS

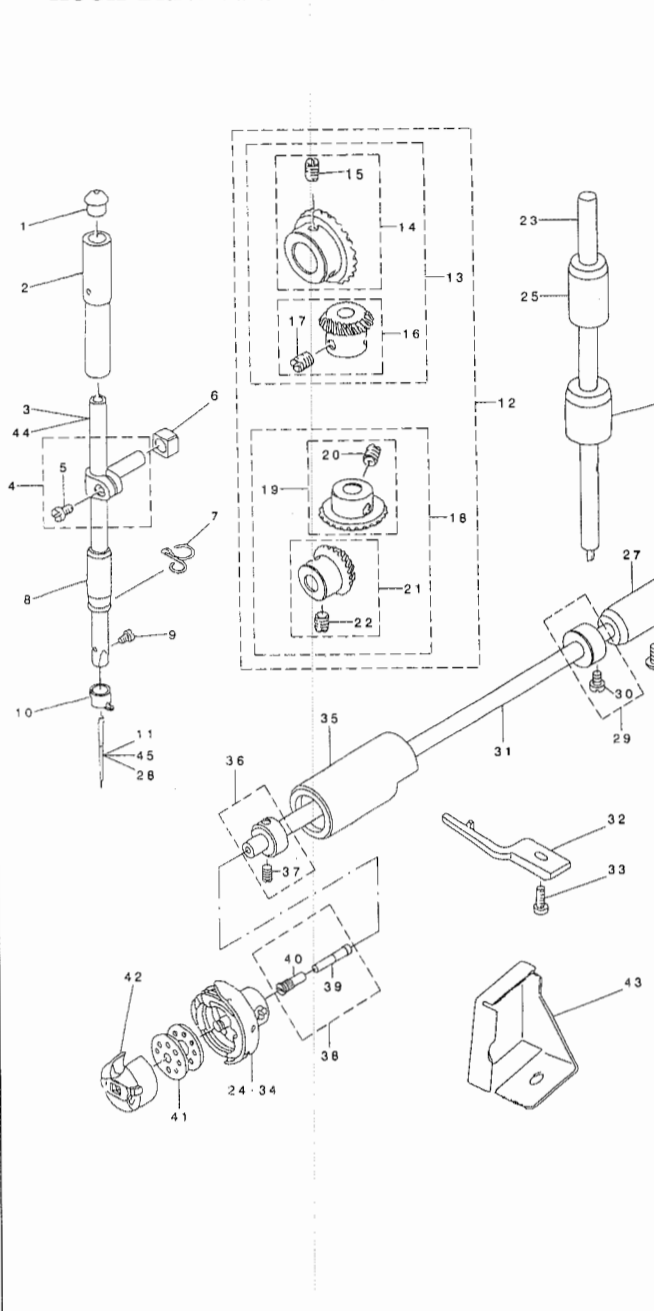

REF.NO	NOTE	PART NO.	DESCRIPTION	Qty
1		110-70851	FACE PLATE ASM.	1
2		110-00304	FACE PLATE GASKET	1
3		SS-6080410-SP	SCREW 1/8-44 L=4	1
4		110-00858	ARM OIL SHIELD ASM.	1
5		TA-0850604-R0	RUBBER PLUG	2
6		TA-1250705-R0	RUBBER PLUG	1
7		B1114-012-000	THREAD GUIDE PIN	1
8		SS-4120915-SP	SCREW 3/16-28 L=9	8
9	#05	111-02605	CORD HOLDER	1
10		110-70901	SIDE PLATE	1
11		110-00619	GASKET	1
12	#01	CM-3002000-01	ATTENTION SEAL	1
13	#06	CM-3002001-A1	SAFETY LABEL..3 (SMALL).	1
14		100-04109	GROUND MARK	1
15		SS-4120615-SP	SCREW 3/16-28 L=6	1
16		TA-2000502-R0	RUBBER PLUG	1
17	#02	SS-6121840-SP	SCREW 3/16-28 L=18	1
18	#02	111-00500	REVERSE FEED LEVER STOPPER	1
19		TA-2101002-R0	RUBBER PLUG	1
20	#02	111-00104	MAGNET CORD RUBBER	1
21		110-72451	THREAD TENSION ASM.	1
22		110-45002	FIRST TENSION POST	(1)
23		110-45200	THREAD TENSION GUIDE	(1)
24		B3214-047-000	BOBBIN WINDER TENSION DISC	(2)
25		110-45101	THREAD TENSION SPRING	(1)
26		110-72402	THREAD TENSION NUT	(1)
27		SS-4120615-SP	SCREW 3/16-28 L=6	1
28		114-00405	THREAD TAKE-UP LEVER COVER	1
29		SS-4120615-SP	SCREW 3/16-28 L=6	1
30		110-18504	ARM THREAD GUIDE A	1
31		110-01500	SCREW	1
32		110-72352	THREAD TENSION ASM.	1
33		110-72204	TENSION NUT	(1)
34		B3120-125-000	ROTATING STOPPER	(1)
35		B3129-012-A00	TENSION SPRING	(1)
36		B3132-552-000	THREAD TENSION DISK PRESSER	(1)
37		B3126-012-000	THREAD TENSION DISK	(2)
38		B3115-552-000	TENSION POST	(1)
39		B3128-012-000	TAKE-UP SPRING	(1)
40		B3111-126-000	TENSION POST SOCKET	(1)
41		SS-8090670-SP	SCREW 9/64-40 L=5.5	(1)
42		SS-8150710-SP	SCREW 15/64-28 L=7	1
43		B3118-552-E00	TENSION RELEASING	1
44		B1109-012-108	THROAT PLATE (1)	1
45		SS-2110920-TP	SCREW 11/64-40 L=8.5	1
46		SS-2110915-SP	SCREW 11/64-40 L=8.5	1
47		110-18803	ARM THREAD GUIDE B	1
48		SS-6110610-TP	SCREW 11/64-40 L=6	1
49		TA-1250400-R0	RUBBER PLUG D=12.5 L=4	2
50		SS-4120915-SP	SCREW 3/16-28 L=9	3
51		110-01658	BED SLIDE ASM.	1
52		B1110-012-000	SLIDE PLATE	(1)
53		110-01609	BED SLIDE SPRING	(1)
54		SS-6060210-SP	SCREW 3/32-56 L=1.9	(2)
55		110-01104	BED SCREW STUD	4
56		WT-0530002-KS	TOOTHED WASHER D=5.3	1
57		110-30400	RUBBER PLATE	1
58	#01	180-77503	THREAD TAKE-UP LEVER COVER	1
59	#03	110-30202	RUBBER BUSHING	1
60	#04	B1109-552-000	THROAT PLATE	1
61	#07	M6008-350-AAC	RESISTANCE PACK AC ASM.	1
62	#08	M6008-350-AAA	RESISTANCE PACK AA ASM.	1
63	#09	M6008-350-AAL	RESISTANCE PACK AL ASM.	1
64	#10	M6008-350-AAF	RESISTANCE PACK AF ASM.	1
65	#07	SS-4121215-SP	SCREW 3/16-28 L=12	1
66	#07	VS-0510002-KP	SPRING WASHER 5.1X0.2X1.3	1
67	#07	WP-0501016-SD	WASHER 5X10.5X1	1

Note #01... FOR JE  
#02... FOR DDL-5550N-3-09,-VB  
DDL-5550N-7-0k,-VB  
#03... FOR DDL-5550N-7-00,-V0  
#04... FOR JA  
#05... EXCEPT DDL-5550N-7-00  
#06... EXCEPT JE  
#07... FOR DDL-5550N-7  
#08... FOR JA (DDL-5550N-7)  
#09... FOR JH (DDL-5550N-7)  
#10... FOR JE (DDL-5550N-7)

REF.NO	NOTE	PART NO.	DESCRIPTION	Qty
1		SS-8151150-SP	SCREW 15/64-28 L=10.5	1
2		110-17357	THREAD TAKE-UP CRANK SHAFT ASM	1
3		110-02904	ROLLER FELT	1
4		110-39070	THREAD TAKE-UP LEVER ASM.	1
5		110-39062	THREAD TAKE-UP LEVER ASM.	(1)
6	#01	B1905-541-B00	NEEDLE BEARING	(1)
7		110-05204	NEEDLE BAR CRANK	(1)
8		B1408-552-000	NEEDLE BAR CRANK ROD	(1)
9		B1903-552-000	LEFT SCREW	(1)
10		110-02169	COUNTERWEIGHT ASM.	1
11		SS-8681650-TP	SCREW 9/32-28 L=16	(1)
12		SS-8660610-TP	SCREW 1/4-40 L=6	(2)
13		RO-0442401-00	RUBBER RING	(1)
14		SS-7681650-TP	SCREW 9/32-28 L=16	(1)
15		110-02110	COUNTER WEIGHT	(1)
16		110-08059	FEED DRIVE ECCENTRIC CAM ASM.	1
17		SS-6661110-SP	SCREW 1/4-40 L=11	(2)
18		110-08000	FEED DRIVE ECCENTRIC CAM	(1)
19		SS-6090650-SP	SCREW 9/64-40 L=6	2
20		110-02409	MAIN SHAFT BUSHING, REAR	1
21		110-02508	OIL SEAL	1
22		RC-1850001-KP	SNAP RING 18.5	1
23		CS-147121A-SH	THRUST COLLAR ASM.D=14.72 W=12	1
24		SS-8660610-TP	SCREW 1/4-40 L=6	(2)
25		110-52107	MAIN SHAFT FRONT BUSHING	1
26		B1215-552-000	OIL ADJUSTING COLLAR	1
27		110-02300	BUSHING, INTERMEDIATE	1
28		HX-0004300-00	CLIP	1
29		B1909-505-000	RUBBER	1
30		110-71461	HAND WHEEL ASM.	1
31	#02	110-71487	HAND WHEEL ASM.	1
32		WP-0450801-SD	WASHER 4.5X10X0.8	(2)
33		SS-8151550-SP	SCREW 15/64-28 L=15	(2)
34		110-71453	HAND WHEEL ASM.	(1)
35		M4007-110-0AA	MAGNET FITTING BASE A ASM.	(1)
36		M4007-110-0AB	MAGNET FITTING BASE B ASM.	(1)
37		SS-6111210-SP	SCREW 11/64-40 L=12	(2)
38		110-32562	DYNAMO STATOR	1
39		SL-4051001-MZ	SCREW M5 L=9.6	2
40		110-03001	OIL AMOUNT ADJUSTING PIN	1
41		RO-0291801-00	RUBBER RING	1
42		110-08109	THRUST COLLAR	1
43		110-02003	MAIN SHAFT	1

Note #01... SELECTIVE PART(A ~ D)  
#02... FOR DDL-5550N-3-0B,-WB

REF.NO	NOTE	PART NO.	DESCRIPTION	Qty
1		B1405-012-000	CAP	1
2		B1402-552-000-A	NEEDLE BAR BUSHING, UPPER	1
3		110-35003	NEEDLE BAR	1
4		B1411-552-0A0	NEEDLE ROD HOLDER ASM.	1
5		SS-6090670-TP	SCREW 9/64-40 L=6	1
6		B1414-555-000	SLIDE BLOCK	1
7		110-18801	NEEDLE BAR THREAD GUIDE	1
8		B1403-155-000	NEEDLE BAR BUSHING, LOWER	1
9		SS-7080510-TP	SCREW 1/8-44 L=4.5	1
10		110-05303	NEEDLE BAR THREAD GUIDE	1
11		WDB-100B1400	NEEDLE DBX1 #14	1
12		B1306-155-0C0	GEAR & PINION ASM.	(1)
13		B1306-155-0B0	GEAR & PINION ASM., UPPER	(1)
14		B1305-012-0A0	GEAR ASM.	(1)
15		SS-8660810-TP	SCREW 1/4-40 L=8	(1)
16		B1306-155-0A0	PINION ASM.	(1)
17		SS-8660810-TP	SCREW 1/4-40 L=8	(1)
18		B1307-155-0B0	GEAR & PINION ASM., LOWER	(1)
19		B1307-155-0A0	GEAR ASM. LARGE	(1)
20		SS-8660810-TP	SCREW 1/4-40 L=8	(1)
21		B1308-155-0A0	PINION ASM.	(1)
22		SS-8660810-TP	SCREW 1/4-40 L=8	(1)
23		110-04009	UPRIGHT SHAFT	1
24		111-41355	HOOK ASM.	1
25		110-04306	BUSHING B, UPPER	1
26		110-04207	UPRIGHT SHAFT BUSHING, LOWER	1
27		110-15807	BUSHING, REAR	1
28	#02	MC-2005007-50	NEEDLE 134 75	1
29		CS-079101A-SH	THRUST COLLAR ASM. D=7.94 W=10	1
30		SS-6110420-TP	SCREW 11/64-40 L=4.8	1
31		110-15005	HOOK DRIVING SHAFT	1
32		110-38809	BOBBIN CASE HOLDER	1
33		SS-6111010-SP	SCREW 11/64-40 L=9.5	1
34	#01	110-38650	HOOK ASM.	1
35		110-15104	BUSHING ASM., FRONT	1
36		CS-079073A-SH	THRUST COLLAR ASM.	(1)
37		SS-8110410-TP	SCREW 11/64-40 L=3.5	(1)
38		110-15955	OIL SEAL SCREW ASM.	1
39		110-15908	OIL WICK	1
40		B1808-552-000	OIL SEAL SCREW	1
41		B9117-012-000	BOBBIN	1
42		110-38759	BOBBIN CASE ASM.	1
43		110-38908	OIL SHIELD	1
44	#04	111-41207	NEEDLE BAR	1
45	#03	MDP-500B1400	NEEDLE DPX5 #14	1
46		SS-4120915-SP	SCREW 3/16-28 L=9	1

Note #01... FOR JH  
#02... FOR JE  
#03... FOR JO  
#04... FOR JE, JO

4. HAND LIFTER COMPONENTS

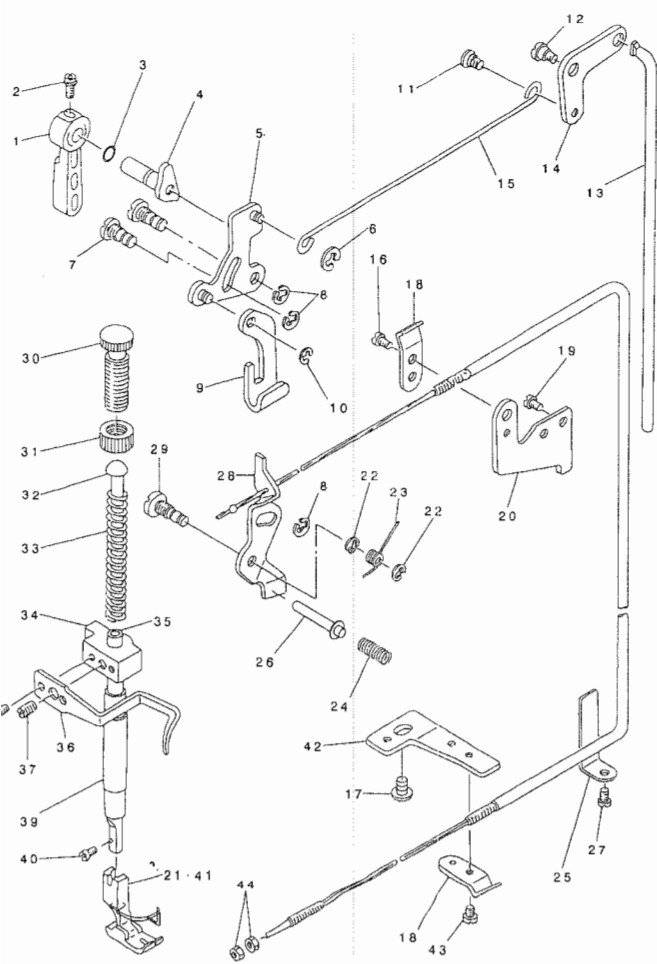

REF. NO	NOTE	PART NO.	DESCRIPTION	Qty
1		110-71800	HAND LIFTER	1
2		B1521-555-000	SCREW	1
3		RO-0371801-00	RUBBER RING	1
4		110-06756	HAND LIFTER CAM ASM.	1
5		110-06350	HAND LIFTER LINK	1
6		RE-0500000-KO	E-RING	1
7		110-06509	LINK SHAFT	2
8		RE-0500000-KO	E-RING	3
9		110-06202	LIFTING LEVER	1
10		110-07309	E-RING	1
11		110-07101	HINGE SCREW	1
12		SD-0720331-SP	HINGE SCREW D= 7.24 H= 3.3	1
13		110-07200	CONNECTING ROD VERTICAL	1
14		110-07002	LIFTING LEVER LINK	1
15		110-06905	LIFTING LEVER CONNECTING ROD	1
16		SS-7110720-SP	SCREW 11/64-40 L=7	1
17	#02	SS-4150915-SP	SCREW 15/64-28 L=9	1
18		110-45408	WIRE HOLDER A	2
19		SS-4120615-SP	SCREW 3/16-28 L=6	1
20		110-45606	WIRE HOLDER BRACKET (UPPER)	1
21	#01	B1524-552-0BA	PRESSER FOOT ASM.	1
22		RE-0500000-KO	E-RING	2
23		110-18207	TENSION RELEASE RETURN SPRING	1
24		110-18405	TENSION RELEASE PIN SPRING	1
25		110-46000	WIRE CABLE HOLDER	1
26		110-18306	TENSION RELEASE SUPPORTING PIN	1
27		SS-4120615-SP	SCREW 3/16-28 L=6	1
28		110-45952	THREAD TENSION RELEASE WIRE	1
29		110-18108	TENSION RELEASE SHAFT	1
30		110-71602	PRESSER SPRING REGULATOR	1
31		110-71701	NUT	1
32		B1510-227-000	PRESSER GUIDE BAR	1
33		B1505-227-000-A	PRESSER SPRING	1
34		110-06004	PRESSER BAR GUIDE BRACKET	1
35		B1501-127-000	PRESSER BAR	1
36		110-06103	PRESSER BAR THREAD GUIDE	1
37		SS-8660810-TP	SCREW 1/4-40 L=8	1
38		SS-6090910-SP	SCREW 9/64-40 L=9	2
39		B1502-541-000	PRESSER BAR BUSHING, LOWER	1
40		SS-7091110-SP	SCREW 9/64-40 L=10.5	1
41		B1524-012-0BA	PRESSER FOOT ASM.	1
42		110-45705	WIRE HOLDER BRACKET (LOWER)	1
43		SS-7110410-SP	SCREW 11/64-40 L=4	1
44		NS-6620310-SP	NUT 3/16-32	2

Note #01...FOR JA  
#02...FOR DDL-5550N-7-00,-W0

5. FEED MECHANISM COMPONENTS

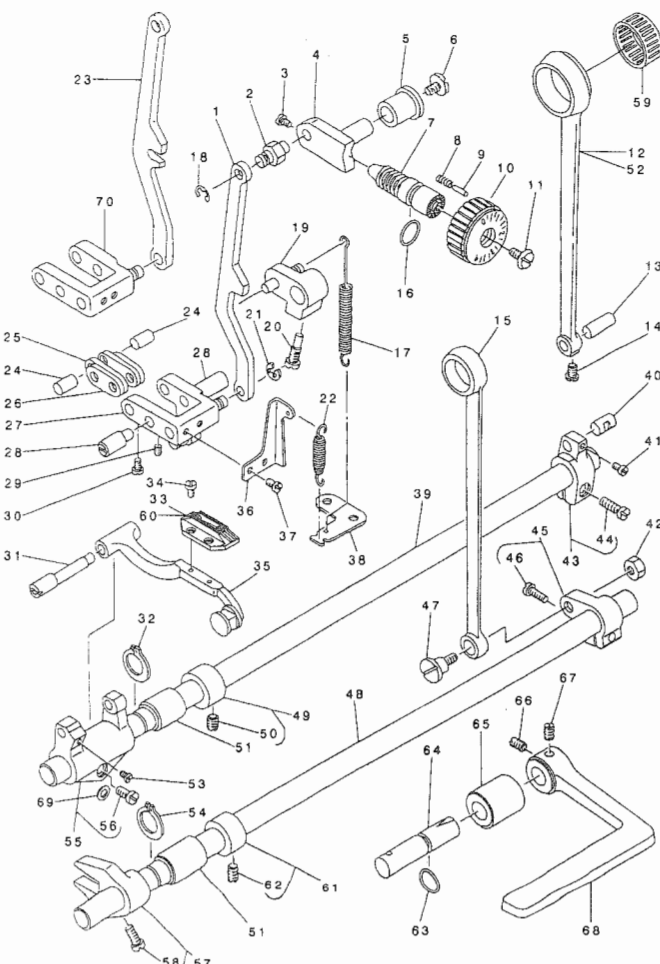

REF. NO	NOTE	PART NO.	DESCRIPTION	Qty
1	#01	111-00401	FEED ADJUST ROD	1
2		110-09602	FEED REGULATOR PIN	1
3		SS-6090670-TP	SCREW 9/64-40 L=6	2
4		110-09701	FEED REGULATOR	1
5		110-11509	FEED REGULATOR BUSHING	1
6		SS-7120770-SH	SCREW 3/16-28 L=7	1
7		110-09909	FEED REGULATOR SCREW	1
8		B1148-555-000	SPRING	1
9		110-52701	PIN	1
10		110-72006	FEED DIAL	1
11		SS-6121860-SP	SCREW 3/16-28 L=18	1
12		110-08208	ROCKER SHAFT CONNECTING ROD	1
13		110-09206	WALKING FOOT PIN C	1
14		SS-6090620-SP	SCREW 9/64-40 L=6	1
15		110-14008	CONNECTING ROD	1
16		RO-0922702-00	RUBBER RING	1
17		110-10303	FEED REVERSE SPRING	1
18		RE-0500000-KO	E-RING	1
19		110-10154	FEED REVERSE ARM ASM.	1
20		110-10410	FEED REVERSE ARM SCREW	1
21		RE-0500000-KO	E-RING	1
22		110-37405	SPRING	1
23	#02	110-09503	FEED REGULATOR CONNECTING ROD	1
24		110-09008	WALKING FOOT PIN A	2
25		110-08703	WALKING FOOT LINK	2
26		110-08604	CONNECTING LINK A	2
27	#01	111-00252	FEED ADJUST LINK ASM.	1
28		110-08802	ADJUSTING LINK FULCRUM SHAFT A	2
29		SS-8150710-SP	SCREW 15/64-28 L=7	2
30		SS-6090620-SP	SCREW 9/64-40 L=6	2
31		110-37207	FEED BAR SHAFT	1
32		RC-0150001-KP	RETAINING RING 13.8	1
33		B1613-012-100	FEED DOG 1	1
34		SS-4080620-TP	SCREW 1/8-44 L=6	2
35		110-37355	FEED BAR ASM.	1
36		110-92301	ADJUSTING LINK SPRING GUIDE	1
37		SS-4110515-SP	SCREW 9/64-40 L=5	2
38		110-11301	FEED SPRING HOOK	1
39		110-10808	FEED ROCKER SHAFT	1
40		110-09107	WALKING FOOT PIN B	1
41		SS-6090620-SP	SCREW 9/64-40 L=6	1
42		NS-6680410-SP	NUT 9/32-28	1
43		110-08356	FEED ROCKER SHAFT CRANK ASM.	1
44		SS-6121610-SP	SCREW 3/16-28 L=15.5	(1)
45		110-14156	REAR CRANK ASM.	1
46		SS-7121610-SP	SCREW 3/16-28 L=15.5	(1)
47		SD-1000801-SH	HINGE SCREW D=10 H=8	1
48		110-14206	FEED DRIVING SHAFT	1
49		CS-147121A-SH	THRUST COLLAR ASM. D=14.72 W=12	1
50		SS-8660610-TP	SCREW 1/4-40 L=6	(2)
51		110-10907	FEED ROCKER SHAFT BUSHING	2
52	#03	110-11400	HORIZONTAL FEED ROD (A)	1
53		SS-7110740-TP	SCREW 11/64-40 L=7	1
54		RC-0150001-KP	RETAINING RING 13.8	1
55		110-37157	FEED BAR CRANK ASM.	1
56		SS-7121410-TP	SCREW 3/16-28 L=14	(1)
57		110-14354	DRIVING SHAFT CRANK ASM.	1
58		SS-7111120-SP	SCREW 11/64-40 L=19.5	(1)
59	#05	B1636-581-C00	NEEDLE BEARING	1
60	#04	B1613-552-000	FEED DOG	1
61		CS-147121A-SH	THRUST COLLAR ASM. D=14.72 W=12	1
62		SS-8660610-TP	SCREW 1/4-40 L=6	(2)
63		RO-0781901-00	RUBBER RING	1
64		110-10519	FEED REVERSE SHAFT	1
65		110-10709	FEED LEVER METAL	1
66		SS-8661030-SP	SCREW 1/4-40 L=10	1
67		SS-8661040-TP	SCREW 1/4-40 L=10	1
68		110-72105	REVERSE FEED CONTROL LEVER	1
69		WP-0480856-SP	WASHER 4.8X8.4X0.8	1
70	#02	110-08455	WALKING FOOT ADJUSTING LINK	1

Note #01...FOR DDL-5550N-3-0B,-WB  
DDL-5550N-7-0B,-WB  
#02...FOR DDL-5550N-7-00,-W0  
#03...FOR JE,JA  
#04...FOR JA  
#05...SELECTIVE PART(FOR JE,JA)

6. THREAD TRIMMER COMPONENTS

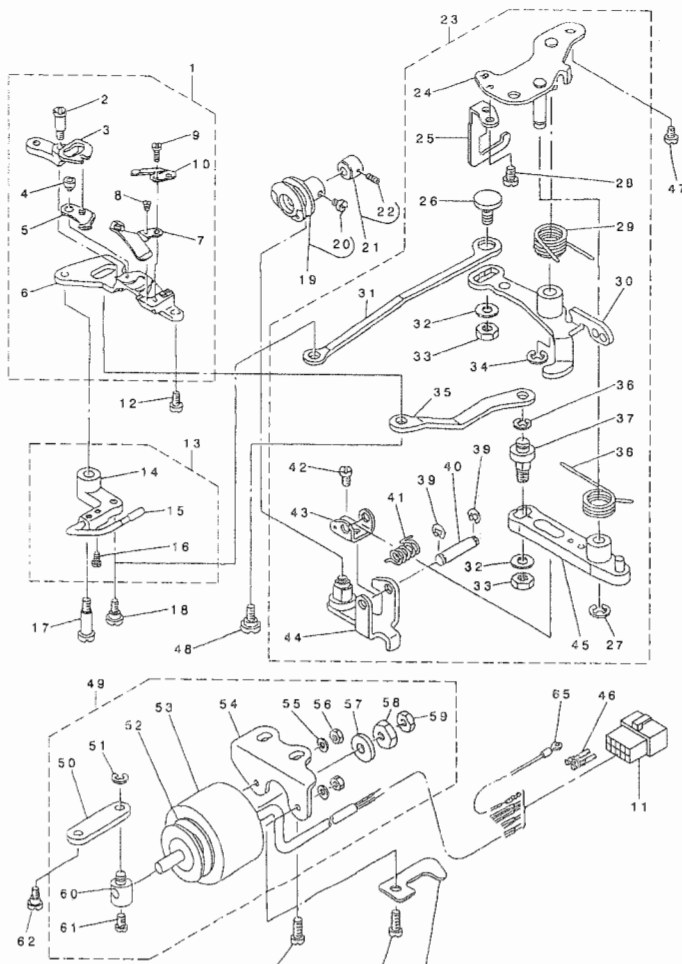

REF. NO	NOTE	PART NO.	DESCRIPTION	Qty
1		110-40359	KNIFE UNIT	1
2		SD-0460703-TP	HINGE SCREW D=4.6 H=7	(1)
3		110-40508	FORKED BASE FOR KNIFE	(1)
4		110-40409	MOVING KNIFE HINGE SCREW	(1)
5		110-40052	MOVING KNIFE ASM.	(1)
6		110-40300	KNIFE MOUNTING BASE	(1)
7		110-40201	THREAD GUIDE FOR KNIFE	(1)
8		SS-20608210-SP	SCREW 3/32-56 L=2.3	(1)
9		SS-4080620-TP	SCREW 1/8-44 L=6	(2)
10		D2406-555-DOH	COUNTER KNIFE	(1)
11		HK-0346101-40	HOUSING 14P	1
12		SS-4110715-SP	SCREW 11/64-40 L=7	1
13		110-42553	PICKER ARM ASM.	1
14		110-42504	PICKER ARM	(1)
15		110-42652	THREAD TAKE-UP PICKER ASM.	(1)
16		SS-6090510-SP	SCREW 9/64-40 L=5	(2)
17		SD-0641451-SP	HINGE SCREW D= 6.35 H=14.5	1
18		SD-0630275-SP	HINGE SCREW D= 6.35 H= 2.7	1
19		110-42850	THREAD TRIMMER CAM ASM.	1
20		SS-6660610-TP	SCREW 1/4-40 L=6	(2)
21		110-42959	CAM COLLAR ASM.	1
22		SS-8110520-TP	SCREW 11/64-40 L= 4.5	(1)
23		110-42264	THREAD TRIMMER DRIVING UNIT	1
24		110-42058	BASE PLATE ASM.	(1)
25		110-42702	DRIVING ARM STOPPER ASM.	(1)
26		110-42306	PICKER LINK PIN	(1)
27		RE-0600000-KO	E-RING 6	(1)
28		SS-4110715-SP	SCREW 11/64-40 L=7	(2)
29		110-41704	CLUTCH SPRING	(1)
30		110-41852	CLUTCH PLATE ASM.	(1)
31		110-42405	PICKER LINK	(1)
32		WP-0621016-SH	WASHER	(2)
33		NS-6150430-SP	NUT 15/64-28	(2)
34		RE-0600000-KO	E-RING 6	(1)
35		110-40607	MOVING KNIFE LINK	(1)
36		RE-0500000-KO	E-RING	(1)
37		110-40706	MOVING KNIFE LINK PIN	(1)
38		110-43700	KNIFE RETURN SPRING, B	(1)
39		RE-0400000-KO	E-SHAPED SNAP RING (4HM)	(2)
40		110-41407	ROLLER FULCRUM SHAFT	(1)
41		110-41506	ROLLER RETURN SPRING	(1)
42		SS-7090610-SP	SCREW 9/64-40 L=6	(1)
43		110-41308	ROLLER ARM BRACKET	(1)
44		110-40953	ROLLER ARM ASM.	(1)
45		110-40854	KNIFE DRIVING ARM ASM.	(1)
46		HK-0346400-0B	PIN CONTACT	2
47		SS-4150915-SP	SCREW 15/64-28 L=9	2
48		SD-0640631-TP	HINGE SCREW D=6.35 H=6.3	1
49		110-43957	SOLENOID UNIT	1
50		110-42207	CLUTCH LINK	(1)
51		RE-0500000-KO	E-RING	(1)
52		110-43205	SOLENOID RUBBER A	(1)
53		110-43908	THREAD TRIMMER SOLENOID	(1)
54		110-43403	SOLENOID BASE	(1)
55		WP-0450000-SD	WASHER 4.5X8X0.5	(2)
56		NH-6040000-SN	NUT M4	(2)
57		110-43304	SOLENOID RUBBER	(1)
58		NS-6660410-SH	NUT	(1)
59		NS-6660430-SP	NUT 1/4-40	(1)
60		110-43007	SOLENOID PIN	(1)
61		SS-6110710-TP	SCREW 11/64-40 L= 6.5	(1)
62		SD-0600361-SP	HINGE SCREW D=6 H=3.6	1
63		SS-4151215-SP	SCREW 15/64-28 L=12	2
64		110-21706	TUBE HOLDER (LOWER)	1
65		110-44054	GROUND WIRE ASM.	1

# DDL-5550N-3,-7 NO.1

## 7. AUTOMATIC REVERSE FEED COMPONENTS

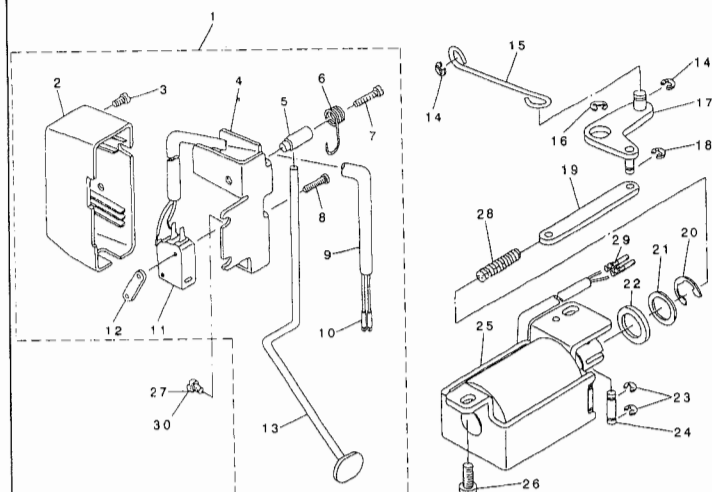

## 8. WIPER COMPONENTS

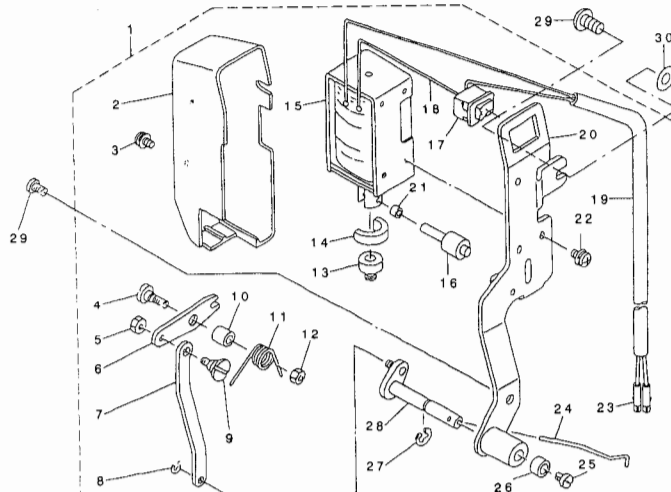

## 9. OIL LUBRICATION COMPONENTS

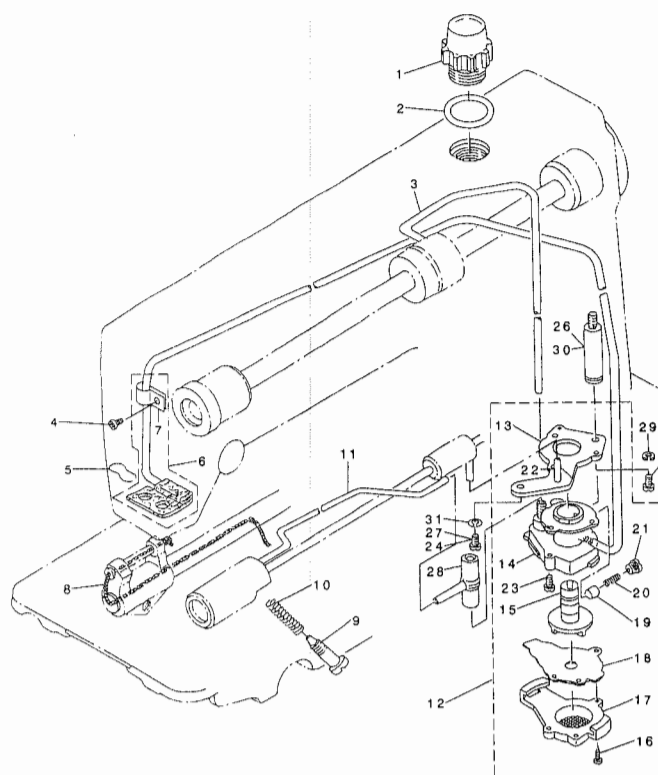

REF.NO	NOTE	PART NO.	DESCRIPTION	Qty
1		110-75058	REVERSE FEED SWITCH ASM.	1
2		110-72501	REVERSE FEED SWITCH COVER	(1)
3		SM-4040655-SP	SCREW M4 L=6	(1)
4		111-02001	REVERSE FEED SWITCH BASE	(1)
5		111-02100	REVERSE FEED SWITCH SHAFT	(1)
6		111-02209	REVERSE FEED SWITCH SPRING	(1)
7		SM-4041655-SP	SCREW M4 L=16	(1)
8		SM-4031501-SC	SCREW M3 L=15	(2)
9		HW-5000700-00	2-CORE CABTYRE CORD	(1.31)
10		HK-0346400-0B	PIN CONTACT	(2)
11		HA-0019000-00	MICROSWITCH	(1)
12		111-02308	MICRO SWITCH PLATE	(1)
13		110-72600	REVERSE FEED SWITCH LEVER	(1)
14		RE-0500000-KP	E-RING 5	2
15		111-01300	REVERSE FEED CONNECTING SHAFT	1
16		RE-0900000-K0	E-RING 9	1
17		111-01151	CONNECTING ARM ASM.	1
18		RE-0400000-KP	E-RING 4	1
19		111-01417	REVERSE FEED CONNECTING LINK	1
20		RE-1200000-K0	E-RING 12	1
21		WP-1602616-SZ	WASHER 16X24X2.6	1
22		D2468-555-B00	RUBBER PLUNGER	1
23		RE-0400000-K0	E-RING 4	2
24		111-01003	PLUNGER ARM PIN	1
25		111-02753	REVERSE FEED MAGNET ASM.	1
26		SS-4151215-SP	SCREW 15/64-28 L=12	2
27		SS-4120915-SP	SCREW 3/16-28 L=9	1
28		112-17601	WALKING FOOT SPRING	1
29		HK-0346400-0B	PIN CONTACT	2
30	#01	SS-4120615-SP	SCREW 3/16-28 L=6	1

Note #01...FOR DDL-5550N-3-0B  
DDL-5550N-7-0B

REF.NO	NOTE	PART NO.	DESCRIPTION	Qty
1		110-75157	WIPER ASM.	1
2		110-72709	WIPER COVER	(1)
3		SL-4030621-SS	SCREW M3 X 6	(1)
4		SD-0650321-TP	HINGE SCREW D=6.5 H=3.2	(1)
5		NS-6090310-SP	NUT 9/64-40	(1)
6		111-10608	WIPER LINK A	(1)
7		111-10905	CONNECTING LINK	(1)
8		RE-0250000-K0	E-RING 2.5	(1)
9		111-11507	WIPER LINK B, HINGE SCREW	(1)
10		111-10707	WIPER HINGE SCREW COLLAR	(1)
11		111-10806	WIPER SPRING	(1)
12		NS-6110310-SP	NUT 11/64-40	(1)
13		111-10400	WIPER RUBBER A	(1)
14		111-10509	WIPER RUBBER B	(1)
15		111-10301	WIPER SOLENOID	(1)
16		111-12000	WIPER SOLENOID PIN	(1)
17		HA-0005900-00	POWER SWITCH	(1)
18		HW-2003900-00	ELECTRIC WIRE	(0.04)
19		HW-5000700-00	2-CORE CABTYRE CORD	(1.33)
20		111-10152	WIPER BASE ASM.	(1)
21		111-11804	WIPER LINK COLLAR	(1)
22		SL-4030641-SE	SCREW M3 X 6	(3)
23		HK-0346400-0B	PIN CONTACT	(2)
24		111-11606	WIPER	(1)
25		SS-6090540-SP	SCREW 9/64-40 L= 5.0	(1)
26		111-11309	BRACKET INSTALLING COLLAR	(1)
27		RE-0500000-K0	E-RING	(1)
28		111-11051	WIPER DRIVING SHAFT ASM.	(1)
29		SS-4120915-SP	SCREW 3/16-28 L=9	1
30	#01	WP-0482086-SD	WASHER 4.8X11.5X2	1

Note #01...FOR DDL-5550N-7-W0

REF.NO	NOTE	PART NO.	DESCRIPTION	Qty
1		110-46604	OIL SIGHT WINDOW	1
2		RO-1952401-00	RUBBER RING	1
3		110-21201	MAIN SHAFT OIL TUBE	1
4		SS-4120615-SP	SCREW 3/16-28 L=6	1
5		B3529-226-000	OIL FELT PRESSER	1
6		110-21151	OIL RETURN TUBE ASM.	1
7		B3536-122-000	HOLDER	1
8		CQ-2520000-00	OIL WICK	0.
9		R3514-412-000	OIL ADJUSTING SCREW	1
10		B2616-372-000	SPRING	1
11		110-21300	OIL TUBE	1
12		110-20054	LUBRICATING OIL PUMP ASM.	1
13		110-20302	OIL PUMP INSTALLING BASE	1
14		110-20005	OIL PUMP	1
15		110-20708	OIL PUMP IMPELLER	1
16		SE-4301041-SR	SCREW D=3 L=10	1
17		110-20203	LUBRICATING OIL PUMP COVER	1
18		110-20807	OIL PUMP IMPELLER COVER	1
19		110-20401	PLUNGER	1
20		110-20609	PLUNGER SPRING	1
21		110-20500	PLUNGER SCREW	1
22		110-20906	HOOK DRIVING SHAFT OIL TUBE	1
23		SL-4030851-SF	SCREW M3 L=8	1
24	#02	SS-4150915-SP	SCREW 15/64-28 L=9	1
25		SS-6111010-TP	SCREW 11/64-40 L= 9.5	1
26	#01	111-00609	OIL PUMP SUPPORT	1
27	#01	SS-4151215-SP	SCREW 15/64-28 L=12	1
28		110-21409	RUBBER JOINT	1
29	#01	WS-0451040-KP	SPRING WASHER 4.5X8.5X1	1
30	#02	113-92107	OIL PUMP SUPPORT	1
31	#01	WS-0651310-KP	SPRING WASHER 6.5X11X1.3	1

Note #01...FOR DDL-5550N-3-0B,-WB  
DDL-5550N-7-0B,-WB  
#02...FOR DDL-5550N-7-00,-W0

10. OIL RESERVOIR COMPONENTS

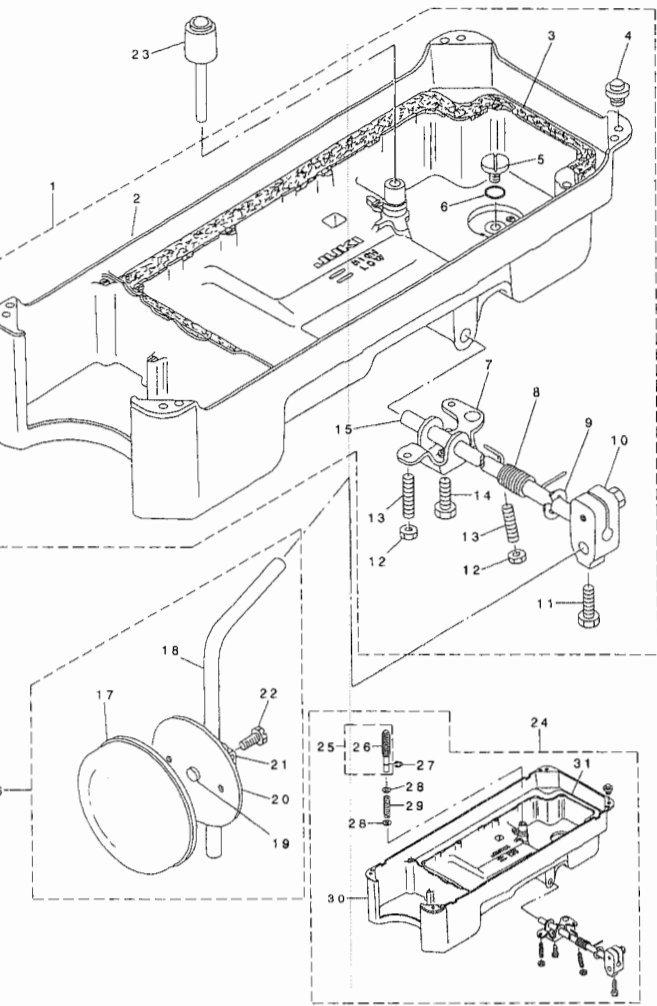

11. BELT COVER & BOBBIN WINDER COMPONENTS

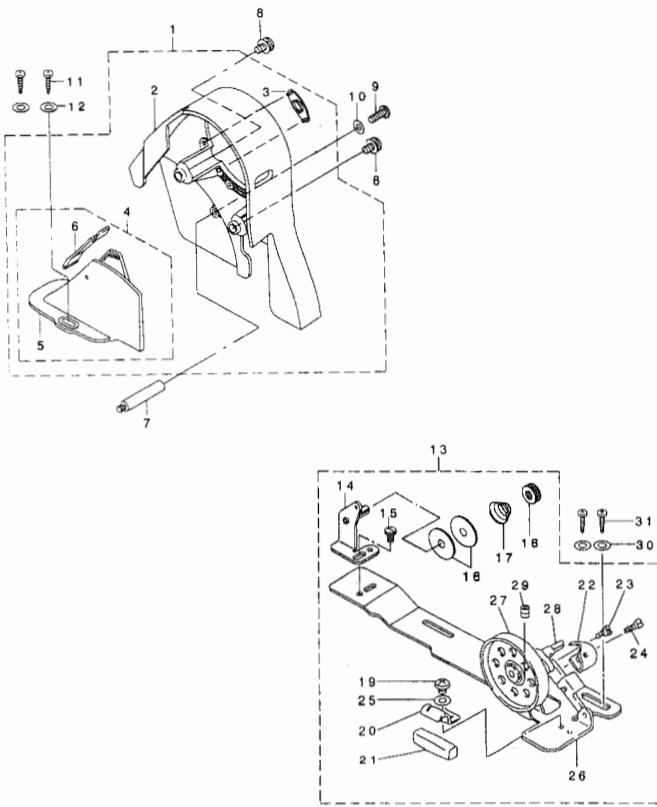

12. THREAD STAND COMPONENTS

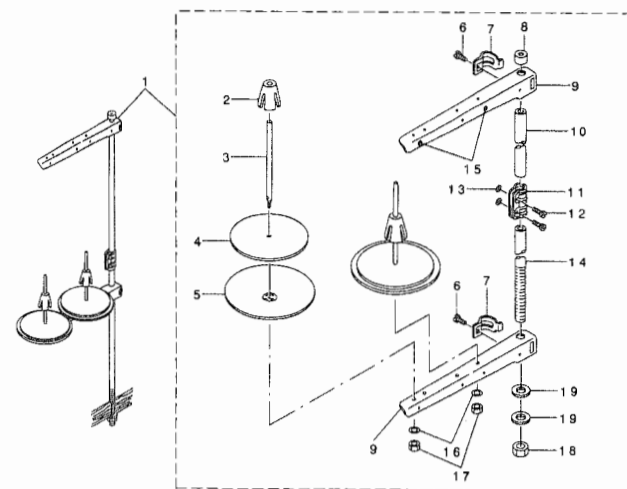

REF.NO	NOTE	PART NO.	DESCRIPTION	Qty
1		110-47057	OIL RESERVOIR ASM.	1
2		110-23017	OIL RESERVOIR	(1)
3		110-24700	GASKET	(1)
4		110-47107	RUBBER CUSHION	(4)
5		SS-6700710-SH	SCREW 5/16-24 L=7	(1)
6		RO-1082401-00	RUBBER RING	(1)
7		110-24015	CONNECTING ROT. VERTICAL	(1)
8		110-24106	E-RING	(1)
9		RE-1000000-KO	E-RING 10	(1)
10		110-24510	BRACKET	(1)
11		SM-9062053-SR	SCREW M6 L=20	(2)
12		NM-6060001-SE	NUT M6	(2)
13		SM-8063012-TR	SCREW M6 L=30	(2)
14		SM-9061853-SR	SCREW M6 L=17.5	(1)
15		110-24205	KNEE PRESS ROD	(1)
16		110-23751	KNEE PRESS PLATE ASM.	1
17		B3431-552-000-A	KNEE PRESS PLATE COVER	(1)
18		B3419-122-000	KNEE LIFTER PLATE ROD	(1)
19		110-24403	RUBBER	(1)
20		110-23702	KNEE PRESS PLATE	(1)
21		110-23801	KNEE PRESS PLATE HOLDER	(1)
22		SM-9061203-SE	SCREW M6 L=12	(1)
23		110-24304	KNEE PRESS LIFTER ROD	1
24	#01	111-41454	OIL RESERVOIR ASM.	1
25	#01	GAK-300010B0	KNEE PRESS LIFTER ROD ASM.	(1)
26	#01	GAK-30004000	KNEE PRESS LIFTER ROD RUBBER	(1)
27	#01	RE-0400000-KO	E-RING 4	(1)
28	#01	WP-0621016-SD	WASHER C. 2X13X1	(2)
29	#01	GAK-30005000	SPRING	(1)
30	#01	111-41413	OIL RESERVOIR	(1)
31	#01	111-41900	GASKET	(1)

Note #01...FOR JE(DDL-5350H-7)

REF.NO	NOTE	PART NO.	DESCRIPTION	Qty
1		110-76650	BELT COVER ASM. (URBANE GREY)	1
2		110-76601	BELT COVER A	(1)
3		110-76700	BELT COVER A CAP	(1)
4		110-76858	BELT COVER B ASM.	(1)
5		110-76809	BELT COVER B	(1)
6		110-76957	BELT COVER B CAP ASM.	(1)
7		110-23504	BELT COVER SUPPORT, A	1
8		110-25202	BELT COVER A SCREW	2
9		SS-4121415-SP	SCREW 3/16-28 L=14	1
10		WP-0501016-SD	WASHER 5X10.5X1	1
11		SK-3412000-SC	WOOD SCREW D=4.1 L=20	2
12		WP-0450826-SC	WASHER 4.5X10X0.8	2
13		110-77567	BOBBIN WINDER COMPL.	1
14		110-78250	THREAD TENSION BRACKET ASM.	(1)
15		SS-7110840-SP	SCREW 11/64-40 L=7.8	(1)
16		B3126-012-000	THREAD TENSION DISK	(2)
17		B3129-012-000	THREAD TENSION SPRING	(1)
18		B3125-012-000	THREAD TENSION NUT	(1)
19		SS-4110515-SP	SCREW 11/64-40 L=3.5	(1)
20		110-78102	PRESSER PLATE	(1)
21		B3211-555-000	RUBBER BRAKE	(1)
22		110-78003	POSITIONING FINGER	(1)
23		SD-0490261-SP	HINGE SCREW D=4.9 H=2.6	(1)
24		SS-7081310-SP	SCREW 1/8-44 L=12.5	(1)
25		WP-0480856-SP	WASHER 4.8X8.4X0.8	(1)
26		110-77500	BOBBIN BASE	(1)
27		110-77609	BOBBIN PULLEY	(1)
28		B3204-555-000	BOBBIN WINDER POST	(1)
29		SM-8040502-TP	SCREW M4X0.7 L=5	(1)
30		WP-0450826-SC	WASHER 4.5X10X0.8	2
31		SK-3412000-SC	WOOD SCREW D=4.1 L=20	2

REF.NO	NOTE	PART NO.	DESCRIPTION	Qty
1		229-30358	THREAD STAND ASM.	1
2		229-31109	SPOOL RETAINER	(2)
3		229-31000	SPOOL PIN	(2)
4		229-30903	SPOOL REST CUSHION	(2)
5		229-30804	SPOOL REST	(2)
6		SM-6061610-SC	SCREW M6 L=16	(2)
7		229-30705	THREAD GUIDE ARM JOINT	(2)
8		229-31406	SPOOL REST ROD RUBBER CAP	(1)
9		229-30507	SPOOL REST ARM	(2)
10		229-30408	SPOOL REST ROD, UPPER	(1)
11		229-31307	SPOOL REST ROD JOINT	(1)
12		SM-4051405-SE	SCREW M5 L=14	(2)
13		NM-6050001-SE	NUT M5	(2)
14		229-30309	SPOOL REST ROD, LOWER	(1)
15		229-31208	THREAD GUIDE	(2)
16		WS-0510002-KN	SPRING WASHER	(2)
17		NM-6050001-SE	NUT M5	(2)
18		NM-6160511-SE	NUT M16X1.5	(1)
19		WP-1702600-SO	WASHER 17X30X2.6	(2)

# DDL-5550N-3,-7 NO.2

## 13. EXCLUSIVE PARTS FOR DDL-5550NH-3 DDL-5550NH-7

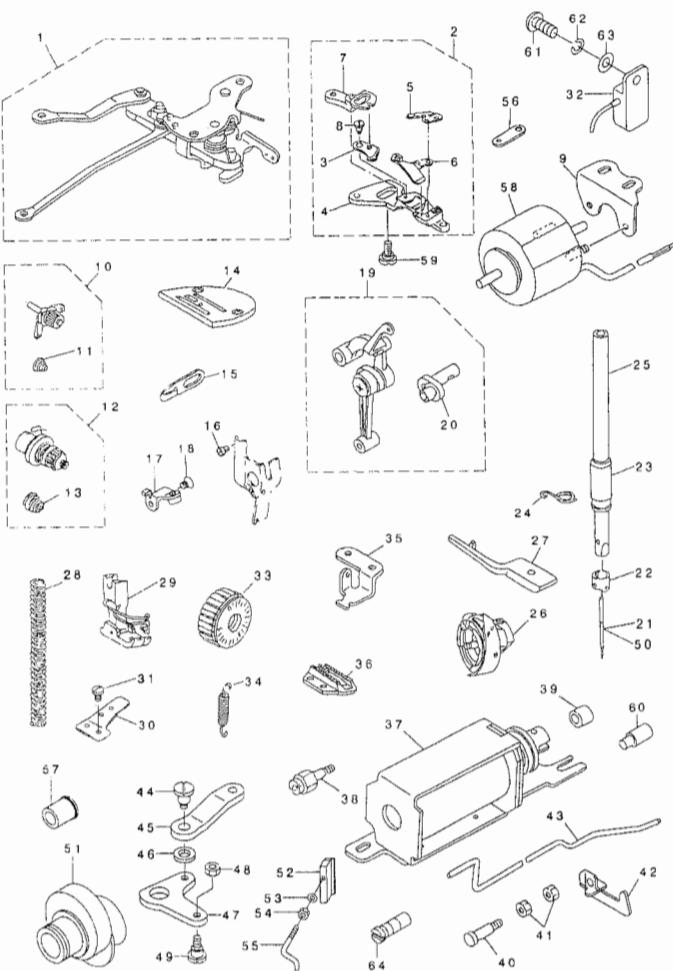

REF. NO	NOTE	PART NO.	DESCRIPTION	Qty
1		110-96062	THREAD CUTTING DRIVING UNIT	1
2		110-95551	KNIFE UNIT	1
3		114-09257	MOVING KNIFE J ASM.	(1)
4		110-95502	KNIFE MOUNT BASE	(1)
5		114-09604	FIX KNIFE	(1)
6		110-95403	KNIFE THREAD GUIDE	(1)
7		110-95601	KNIFE BRANCH	(1)
8		SD-0500131-TP	HINGE SCREW D=5 H=1.25	(1)
9		110-94901	SOLENOID BASE	1
10		110-73954	THREAD TENSION ASM.	(1)
11		110-93606	THREAD TENSION SPRING	(1)
12		110-73657	THREAD TENSION ASM.	(1)
13		B3114-232-000	THREAD TENSION SPRING	(1)
14		114-00801	THROAT PLATE J	(1)
15		110-91006	ARM THREAD GUIDE (HA)	1
16		SS-6080320-SP	SCREW 1/8-44 L= 2.5	1
17		110-95254	LEVER STOPPER ASM.	1
18		SS-1120710-SP	SCREW 3/16-28 L=6.5	1
19		110-91659	LINK THREAD TAKE-UP LEVER ASM.	1
20		110-91600	NEEDLE BAR CRANK H	(1)
21		MDB-10082100	NEEDLE DBX1 #21	1
22		B1418-415-H00	NEEDLE BAR THREAD GUIDE	1
23		B1403-553-000	NEEDLE BAR BUSHING, LOWER	1
24		B1419-553-000	NEEDLE BAR THREAD GUIDE	1
25		110-91303	NEEDLE BAR	1
26		110-92251	LUBRICATING BOBBIN ASM.	1
27		110-93804	POSITIONING FINGER H	1
28		B1505-552-000-A	PRESSER SPRING	1
29		D1524-555-EBL	PRESSER FOOT ASM.	1
30	#02	112-30901	WIRE PRESSER PLATE, B	1
31	#02	SS-7110740-TP	SCREW 11/64-40 L=7	1
32	#03	M6009-350-AAA	RESISTANCE PACK AA ASM.	1
33		110-71909	FEED DIAL	1
34		110-91204	ADJUST LINK SPRING	1
35		110-91907	FEED SPRING HOOK	1
36		114-03003	FEED J	1
37	#02	110-96658	SOLENOID MOUNTING BASE ASM.	1
38	#02	112-31503	OIL PUMP SUPPORT	1
39	#02	112-28103	REVERSE FEED BASE COLLAR	1
40	#02	113-14408	PLUNGER ARM PIN	1
41	#02	NS-6110420-SP	NUT 11/64-40	2
42	#02	112-28301	TUBE HOLDER, LOWER	1
43		110-94109	OIL TUBE	1
44	#02	SD-0700711-TP	HINGE SCREW D=7 H=7.1	1
45	#02	111-01607	SOLENOID CONNECTING LINK	1
46	#02	WP-0722316-SH	WASHER	1
47	#02	111-01508	REVERSE FEED LINK	1
48	#02	NS-6110420-SP	NUT 11/64-40	1
49	#02	SD-0700451-TP	HINGE SCREW D=7 H=4.5	1
50	#01	MC-2005013-00	NEEDLE 134 NH130	1
51		110-80900	FEED DRIVE ECCENTRIC CAM	1
52		114-03805	THREAD GUIDE C FITTING PLATE	1
53		WP-0371016-SD	WASHER 3.7XRX1	1
54		NS-6090310-SP	NUT 9/64-40	1
55		113-05513	ARM THREAD GUIDE, C	1
56		110-94604	CLUTCH LINK	1
57	#02	110-09800	FEED REGULATOR BUSHING	1
58		110-96500	THREAD TRIMMER SOLENOID	1
59		SD-0550701-TP	STEP-SCREW D=5.5 H=7	1
60	#02	110-08901	ADJUSTING LINK FULCRUM SHAFT B	1
61	#03	SS-4121215-SP	SCREW 3/16-28 L=12	1
62	#03	WS-0510002-KP	SPRING WASHER 5.1X9.2X1.3	1
63	#03	WP-0501016-SD	WASHER 5X10.5X1	1
64		B1213-552-000-A	OIL ADJUSTING PIN	1

Note #01... FOR JE  
#02... FOR DDL-5550NH-3-OB, -WB  
DDL-5550NH-7-OB, -WB  
#03... FOR DDL-5550NH-7

## 14. EXCLUSIVE PARTS FOR DDL-5550NH-3 DDL-5550NH-7

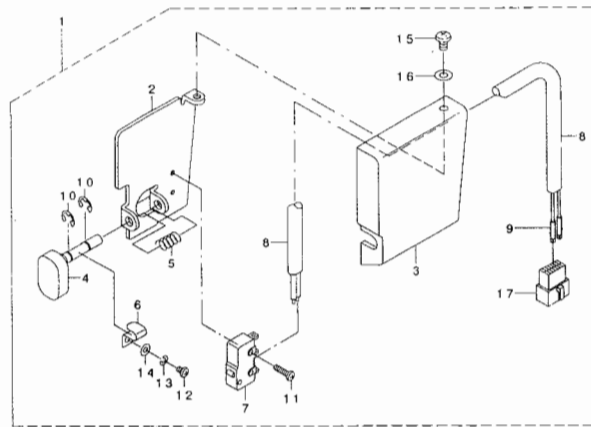

REF. NO	NOTE	PART NO.	DESCRIPTION	Qty
1	#01	110-97052	REVERSE FEED SWITCH ASM.	1
2		111-61007	SWITCH BASE	(1)
3		110-97102	SWITCH COVER	(1)
4		110-97201	KEY TOP	(1)
5		111-61403	SWITCH RETURN SPRING	(1)
6		111-61502	SWITCH LEVER SPRING	(1)
7		111-61601	LIMIT SWITCH	(1)
8		HW-5000700-00	2-CORE CABLEYRE CORD	(1.45)
9		HK-0346400-0B	PIN CONTACT	(1)
10		RE-0320000-K0	E-RING 3.2	(2)
11		SM-4020801-SC	SCREW W2 X 8	(2)
12		SM-4020301-SC	SCREW W2X0.4 L=3	(2)
13		WS-0210002-KN	SPRING WASHER W2	(1)
14		WP-0220301-SC	WASHER W2	(1)
15		SM-4030501-SN	SCREW W3 L=5	(1)
16		WP-0320501-SC	WASHER W3	(1)
17		HK-0346101-40	HOUSING 14P	(1)

Note #01... FOR JH

## 15. WIPER COMPONENTS (FOR DDL-5550NH-3-OB, DDL-5550NH-7-OB)

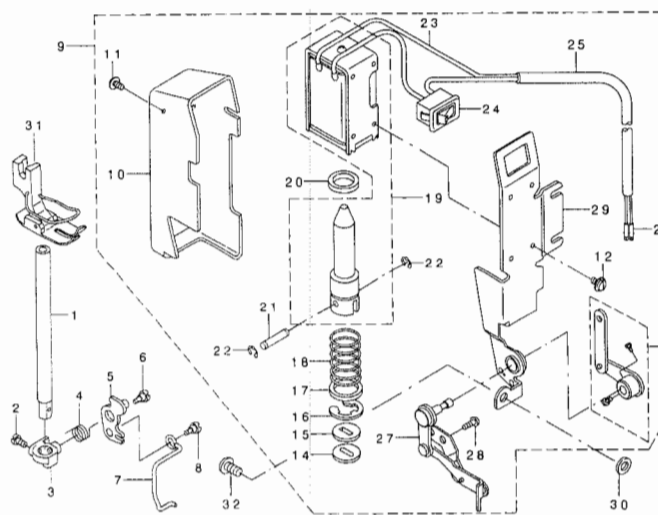

REF. NO	NOTE	PART NO.	DESCRIPTION	Qty
1		MAV-02128000	PRESSER BAR	1
2		SS-6110650-TP	SCREW 11/64-40 L=5.5	1
3		114-12509	WIPER BASE	1
4		114-12608	WIPER ARM SPRING	1
5		114-12764	WIPER ARM ASM.	1
6		SD-0550212-TP	HINGE SCREW D=5.5 H=2.1	1
7		114-14612	WIPER STANDARD	1
8		SS-8090580-TP	SCREW 9/64-40 L=4.5	1
9		114-15759	WIPER ASM., F	1
10		114-11006	WIPER COVER	(1)
11		SL-4030621-SS	SCREW W3	(1)
12		SL-4030641-SE	SCREW	(4)
13		114-11758	WIPER CONNECTING LINK ASM.	(1)
14		112-34606	STOPPER RUBBER WASHER	(1)
15		112-33301	STOPPER RUBBER	(1)
16		RE-1200000-K0	E-RING 12	(1)
17		WP-1651616-SD	WASHER	(1)
18		114-11402	WIPER MAGNET SPRING	(1)
19		114-11105	WIPER SOLENOID	(1)
20		114-11303	PLUNGER STOPPER RUBBER	(1)
21		114-11600	PLUNGER CONNECTING PIN	(1)
22		RC-0330415-KP	SNAP RING	(2)
23		HW-2003900-00	ELECTRIC WIRE	(0.04)
24		HA-0005900-00	POWER SWITCH	(1)
25		HW-5000700-00	2-CORE CABLEYRE CORD	(1.33)
26		HK-0346400-0B	PIN CONTACT	(2)
27		114-12350	SLIDE BASE ASM.	(1)
28		SS-4110515-SP	SCREW 11/64-40 L=5	(2)
29		114-13051	WIPER ADJUSTING BASE ASM.	(1)
30		WP-0611620-SP	WASHER 15X10.6	(1)
31		D1524-555-ECL	PRESSER FOOT ASM.	1
32		SS-4120915-SP	SCREW 3/16-28 L=9	1

6. EXCLUSIVE PARTS FOR DDL-5550NA-7

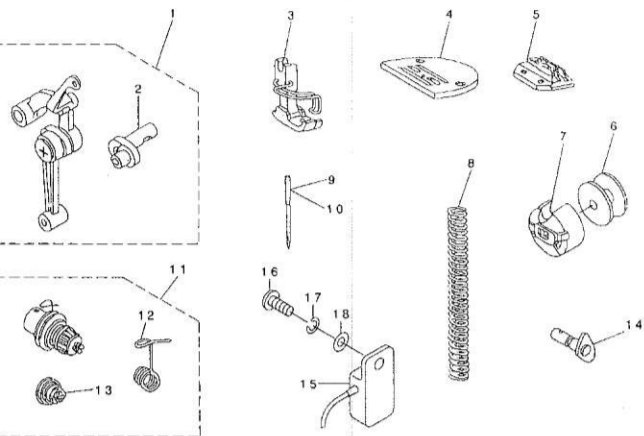

REF. NO	NOTE	PART NO.	DESCRIPTION	Qty
		110-91857	LINK THREAD TAKE-UP LEVER ASM.	1
		110-91808	NEEDLE BAR CRANK A	(1)
		D1524-555-DBA	PRESSER FOOT ASM.	1
		B1109-012-10B	THROAT PLATE (I)	1
		B1613-012-100	FEED DOG I	1
		B9117-552-A00	BOBBIN	1
		B1837-012-OA0	BOBBIN CASE ASM.	1
		B1505-227-T00-A	PRESSER SPRING T	1
#01		MC-2005006-50	NEEDLE 134 NM65	1
		MDA-10080900	NEEDLE DAX1 #9	1
		110-73756	THREAD TENSION ASM.	1
		D3128-555-D00	TAKE-UP SPRING	(1)
		D3129-555-D00	THREAD TENSION SPRING	(1)
		110-92558	HAND LIFTER CAM ASM.	1
		M6018-350-AAA	RESISTANCE PACK AA ASM.	1
		SS-4121215-SP	SCREW 3/16-28 L=12	1
		WS-0510002-KP	SPRING WASHER 5.1X9.2X1.3	1
		WP-0501016-SD	WASHER 5X10.5X1	1

Note #01... FOR JE

17. EXCLUSIVE PARTS FOR DDL-5550NK-7

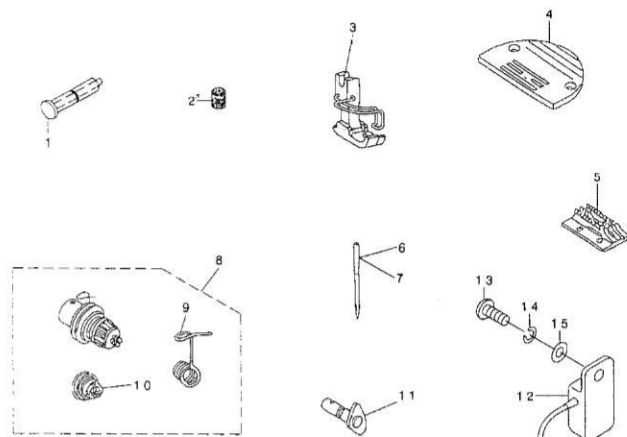

REF. NO	NOTE	PART NO.	DESCRIPTION	Qty
1		110-39351	CRANK SHAFT ASM.	1
2		110-39203	FELT	(1)
3		D1524-555-DBA	PRESSER FOOT ASM.	1
4		110-01906	THROAT PLATE K	1
5		D1613-155-W00	FEED DOG W	1
6	#01	MC-2005006-50	NEEDLE 134 NM65	1
7		MDB-10080900	NEEDLE DBX1 #9	1
8		110-73756	THREAD TENSION ASM.	1
9		D3128-555-D00	TAKE-UP SPRING	(1)
10		D3129-555-D00	THREAD TENSION SPRING	(1)
11		110-92558	HAND LIFTER CAM ASM.	1
12		M6018-350-AAA	RESISTANCE PACK AA ASM.	1
13		SS-4121215-SP	SCREW 3/16-28 L=12	1
14		WS-0510002-KP	SPRING WASHER 5.1X9.2X1.3	1
15		WP-0501016-SD	WASHER 5X10.5X1	1

Note #01... FOR JE