



**JUKI**  
*Union Special*

CYLINDER BED COVERSEAM MACHINES

MFC7000 Series

**ADJUSTING INSTRUCTIONS**

---

NEW ADJUSTMENTS FOR MFC7000

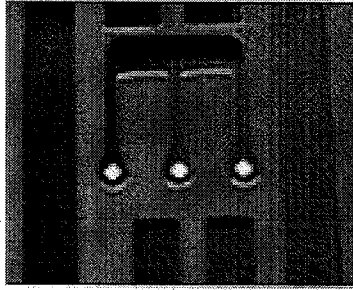

Fig. 1

- 1) Align the needle head so it is square to the line of feed. All needles should clear the front of the throat plate needle holes equally.

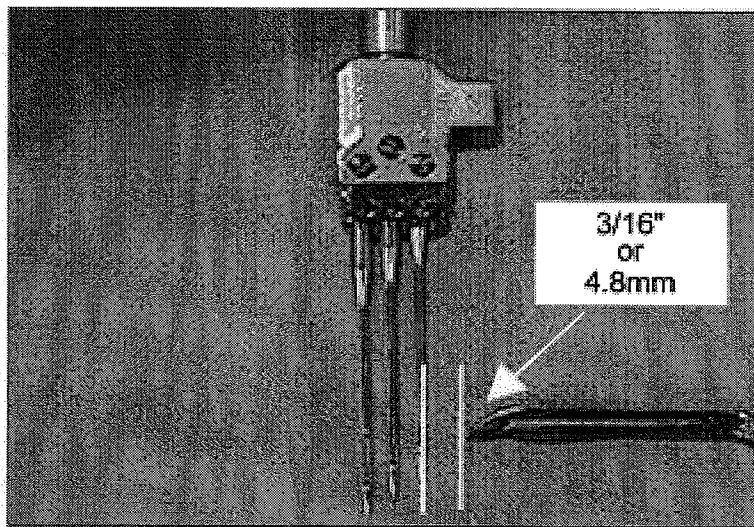

Fig. 2

- 2) With the looper at its far right position, set the looper gauge to be 3/16" (4.8mm).

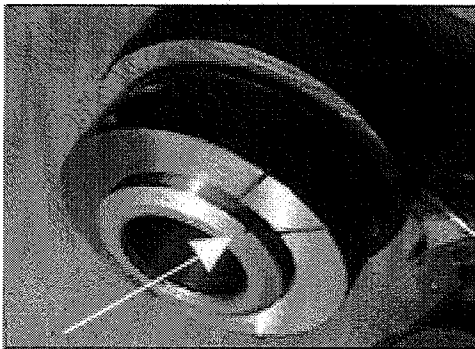

Fig. 3

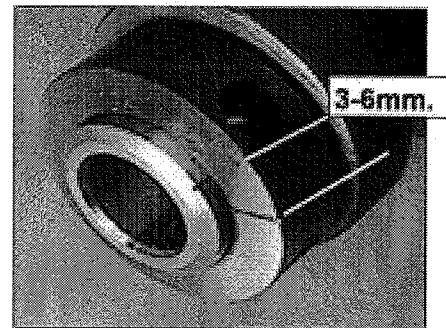

Fig. 3A

- 3) Adjust the looper motion eccentric so the eccentric line is centered between the two adjusting lines.
- 3A) If the eccentric in your machine only has one adjusting line on the eccentric set the eccentric line (3-6mm) to the rear of the adjusting line.

NOTE: The 3-6mm measurement must be taken from the top of the eccentric.

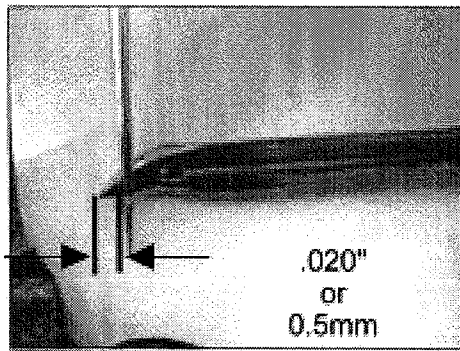

Fig. 4

- 4) The needle bar height should be set so the looper point is .020" past the left needle when the bottom of the looper is even with the top of the needle eye.

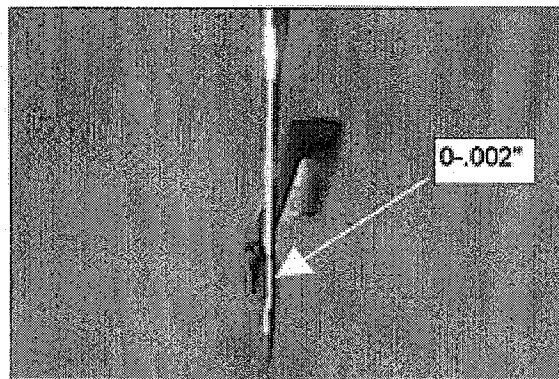

Fig. 5

- 5) Remove all needles except the left. Adjust the looper holder so the tip of the looper is 0-.002" away from the scarf of the left needle.

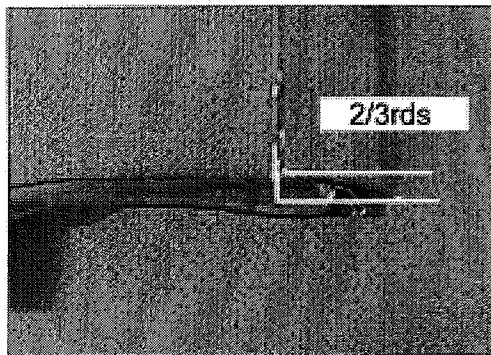

Fig. 6

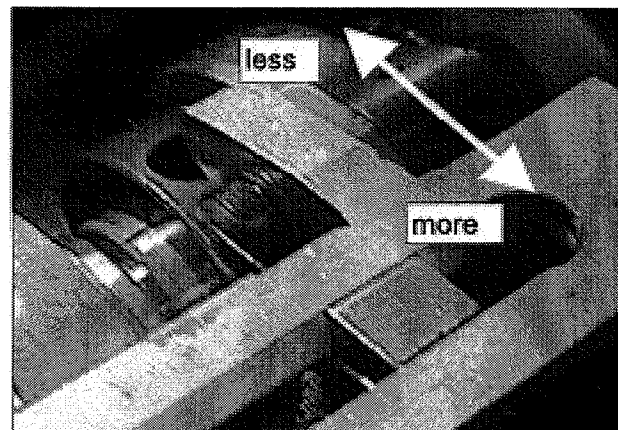

Fig. 6A

- 6) Set the avoid motion so the left needle touches the back of the looper 2/3rds of the way down on the down stroke.

- 6A) To adjust the avoid motion, loosen the screw and nut in the looper cam guide, then move the screw back for less avoid and forward for more avoid.

NOTE: Every time the screw is moved looper front to back must be reset (step 6).

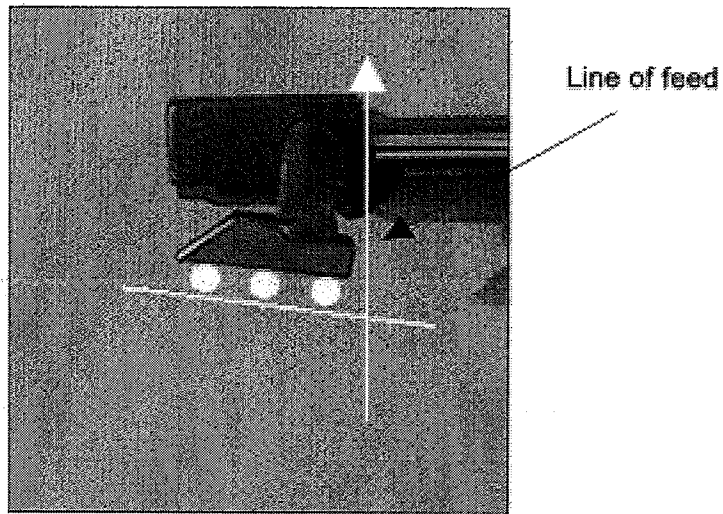

Fig. 7

- 7) Adjust the guard so when the looper reaches the right needle, there is 0-.002" between the needle and the looper point. Use the rear guard to push the right and middle needle forward slightly. The rear guard should touch but not deflect the left needle.

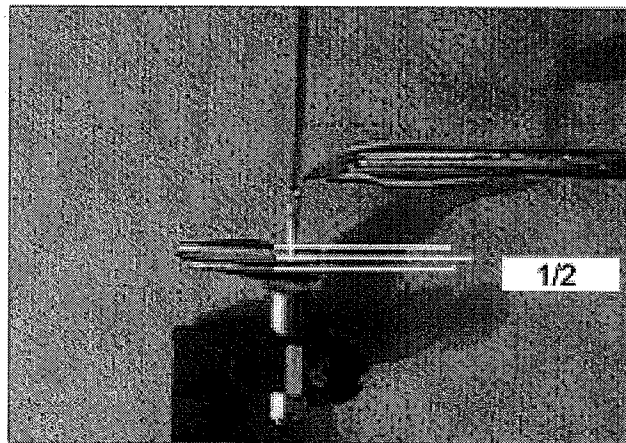

Fig. 8

- 8) The right needle point should be half way up the guarding surface when the looper point is even with the right side of the right needle.

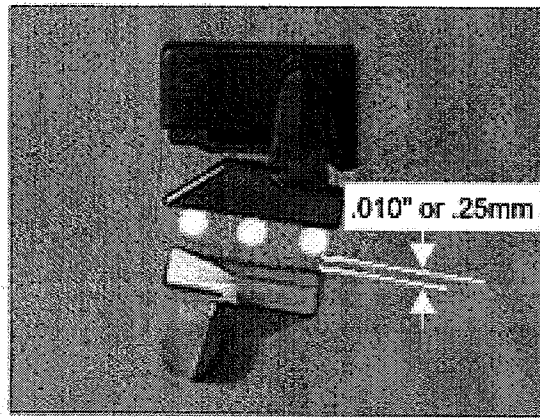

Fig. 9

9) Set the front needle guard to be parallel to the needles. The guard should have .010" (.25mm) clearance to all needles.

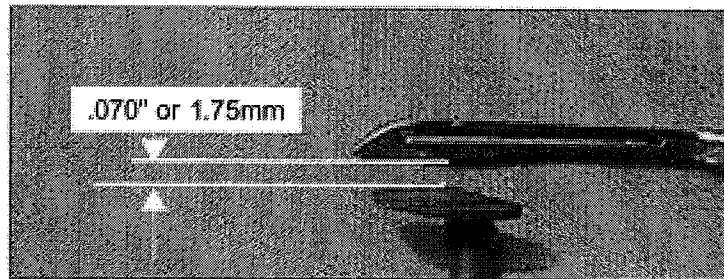

Fig. 10

10) There should be a clearance of .070"(1.75mm) between the top of the front needle guard and the bottom of the looper blade.

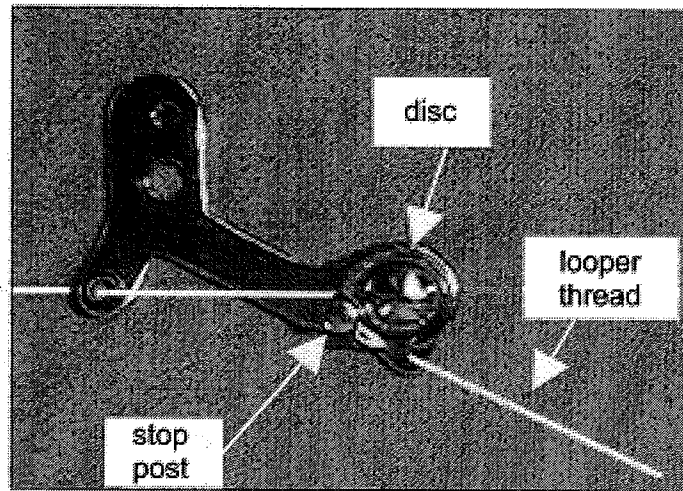

Fig. 11

11) Thread looper nipper between discs and behind the disc stop post.

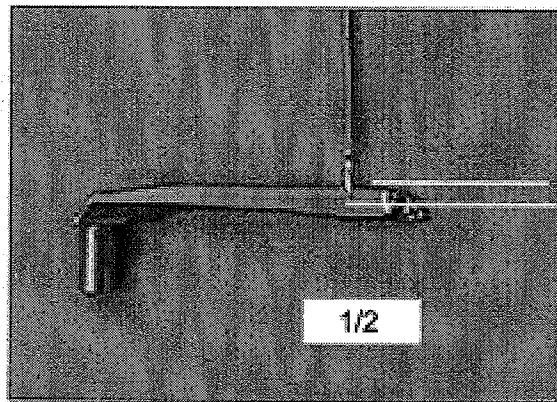

Fig. 12

12) Set the looper cam to cast-off the looper thread when the left needle tip is half way down the BACK of the looper.





**JUKI**  
*Union Special*